

NORTHGATE

TAKING CARE OF EVERY ASPECT



ANTARES VERTICAL BLIND 127/89/63

NORTHGATE

TAKING CARE OF EVERY ASPECT

Northgate, PO Box 200, Barnet, Herts EN4 9EW

Tel 020 8441 4545 **Fax** 020 8441 4888

Website www.northgateuk.com **Email** enquiries@northgateuk.com



ANTARES 127/89/63 VERTICAL BLIND

Antares vertical blinds are available with 127, 89 or 63mm louvres. They have a 40x25mm premium profiled white aluminium headrail with top and face fix brackets and replaceable plastic wheel carrier trucks. The constant transport of the louvres is guaranteed by the precision made aluminium spindle shaft. They are chain or wand control operated with built in slip clutch for louvre tilt. The option is available for sewn in weights for infection control measures. The Antares system is robust with high quality performance yet remains pleasing to the eye. The compressive truck options satisfy the most demanding of environments whether it is residential, commercial or education.

The Antares Vertical blinds are also available with the Magnetic Anti-ligature system. This system ensures that under excess load, the headrail separates from the brackets leaving no remaining points of ligature, creating safe environments where occupants are vulnerable to self harm, and peace of mind for staff.

ANTARES 127/89/63 VERTICAL BLIND - ALSO AVAILABLE WITH THE MAGNETIC ANTI-LIGATURE SYSTEM

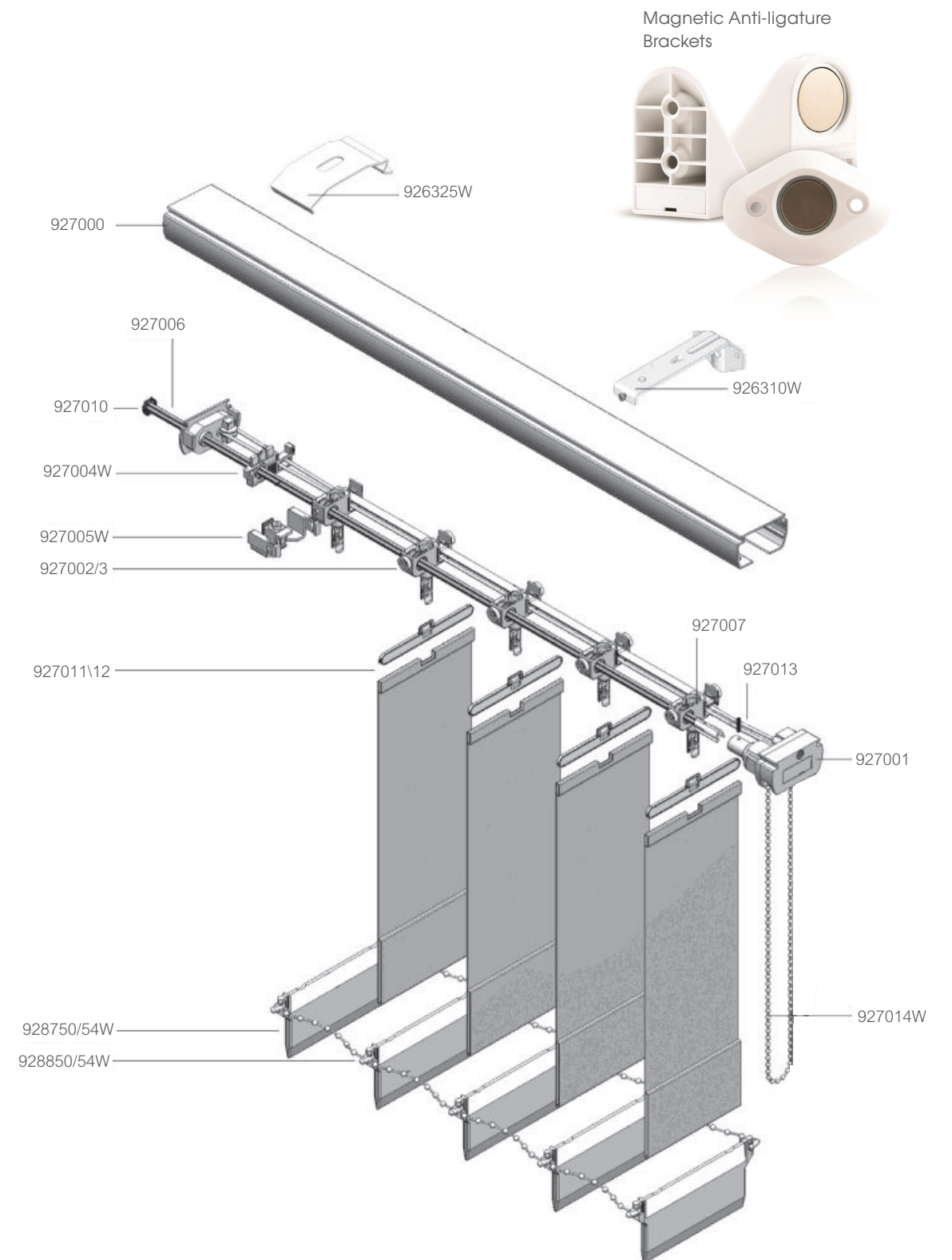

N **LIFETIME WARRANTY** This fabric range comes with a full **Lifetime Warranty** as standard.

For more information and images please visit our website at:

WWW.NORTHGATEUK.COM/PRODUCT-CATEGORY/BLINDS/VERTICAL-LOUVRE