

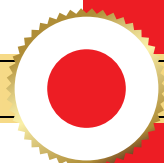

MARUICHI SUN STEEL JOINT STOCK COMPANY

Group Company of
MARUICHI STEEL TUBE LTD., JAPAN

COMPANY
PROFILE



JAPANESE QUALITY



INDEX

3	Introduction
4	Certificates
6	Manufacturing Process of Coil Products
8	Manufacturing Process of Pipe & Tube Products
10	Coil Products
12	Pipe & Tube Products
16	Testing Equipments
17	Coil Products Supply Record
18	Pipe Products Supply Record
20	Maruichi Sun Steel (Hanoi) Co., Ltd.
22	Maruichi Group



MARUICHI SUN STEEL JOINT STOCK COMPANY (SUNSCO), a 100% foreign capital company, was established in 1996 with the purpose of supplying High Quality steel products to Vietnamese local market.

After starting the operation of Steel Pipe Mill in 1998, we have continued to expand our production facilities such as, Color Coating Line, Continuous Galvanizing Line, Cold Rolling Mill, Push-Pull Pickling Line and 16 in Steel Pipe Mill, including our own Power Generating Plant.

In 2013, we also have started No.2 Continuous Galvanizing Line and No.2 Color Coating Line enable us to develop higher Quality products, more volume of production quantity to satisfy the market demand.

Utilizing all those above mentioned facilities, we are currently manufacturing and selling following products;

- Hot-dip 55%Al-Zn Coated Steel Coil
- Hot-dip Galvanized Steel Coil (HR base metal and CR base metal)

- Prepainted hot-dip 55%Al-Zn Coated Steel Coil
- Carbon Steel Pipe & Tube
- Galvanized Steel Pipe & Tube

With regard to above Coils and ERW-Pipe & Tube certified with JIS, we are the first and sole manufacturer in Vietnam who is allowed to put JIS-mark on the products.

We are supplying those products not only in Vietnamese local market but also to overseas market as well, such as to ASEAN countries, Australia and USA.

We commit ourselves that, as a group company of Maruichi Steel Tube Ltd.,Japan,

We will keep improving our quality and service in order to contribute to the development and quality needs to build up infrastructure of Vietnam, as well as for the safety of all the people using our products.

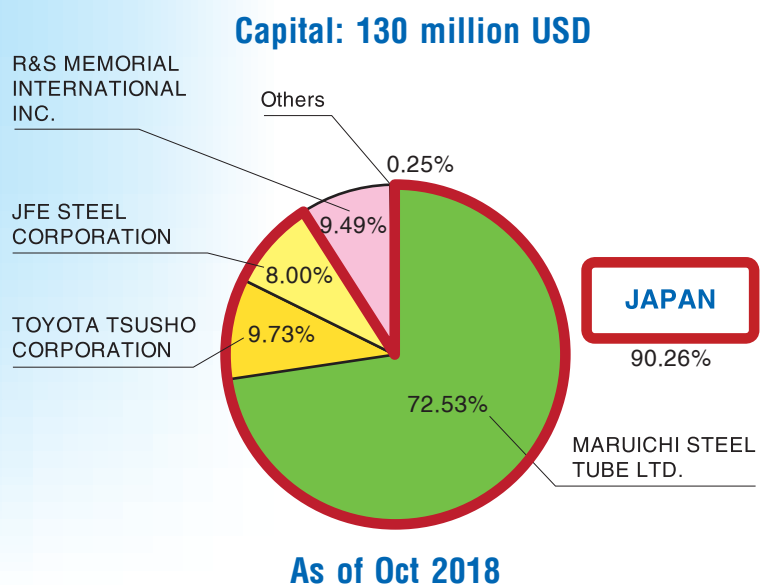

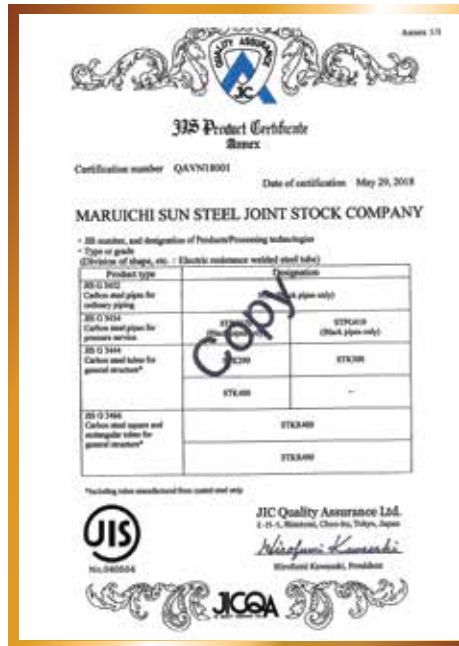

1. JIS Certificate (Pipe) G 3452, G 3454, G 3444, G 3466

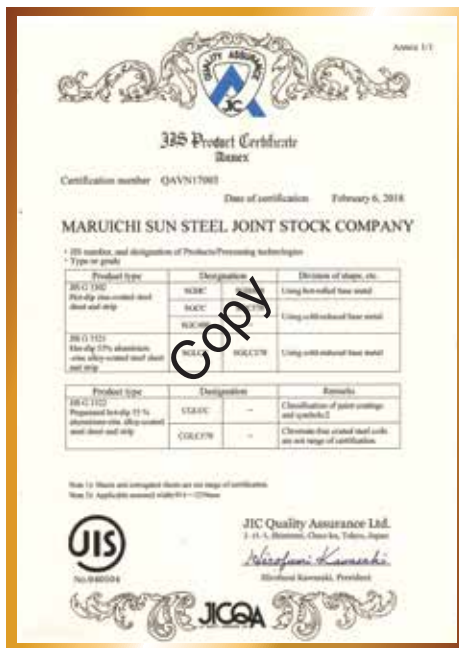

2. JIS Certificate (Coil) G 3302, G 3321, G 3322

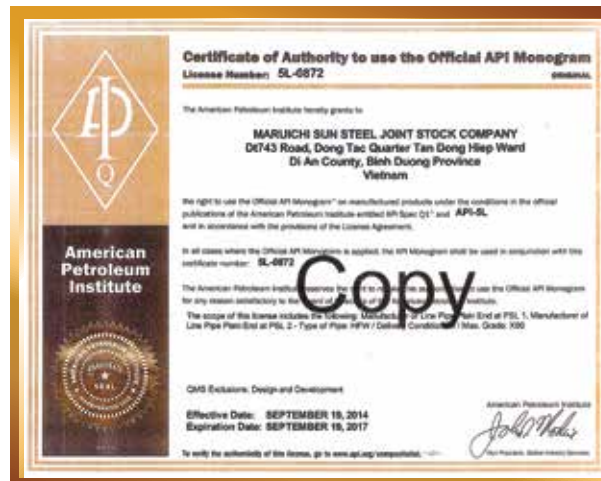

3. API Spec 5L Certificate



4. MS 2383 Certificate



5. MS 1196 Certificate



6. ISO/IEC 17025 Certificate



7. ISO 9001 Certificate



8. ISO 14001 Certificate

6-HIGH COLD ROLLING MILL

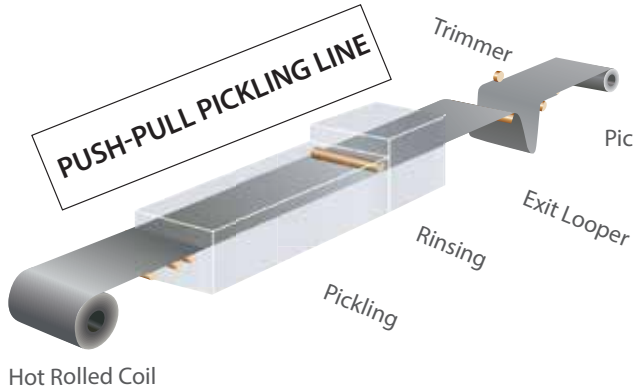
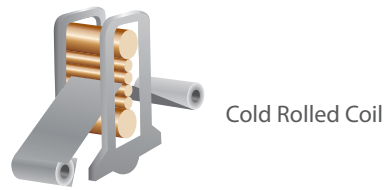

Hot-dip Galvanized Steel Coil
Hot-dip 55% Al-Zn Coated Coil

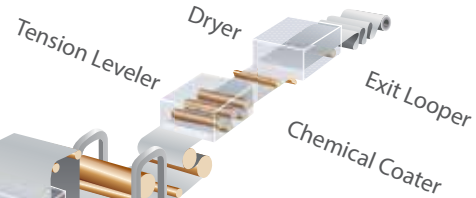

CONTINUOUS GALVANIZING LINE

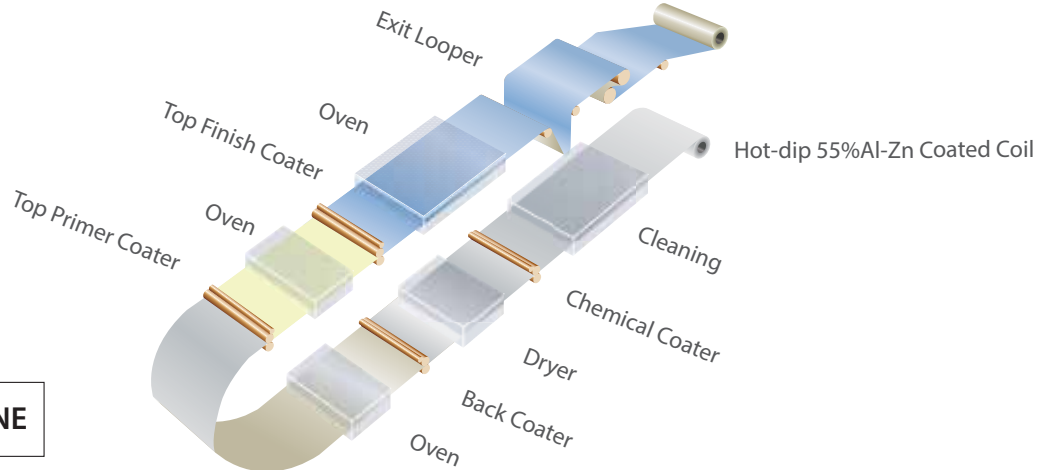
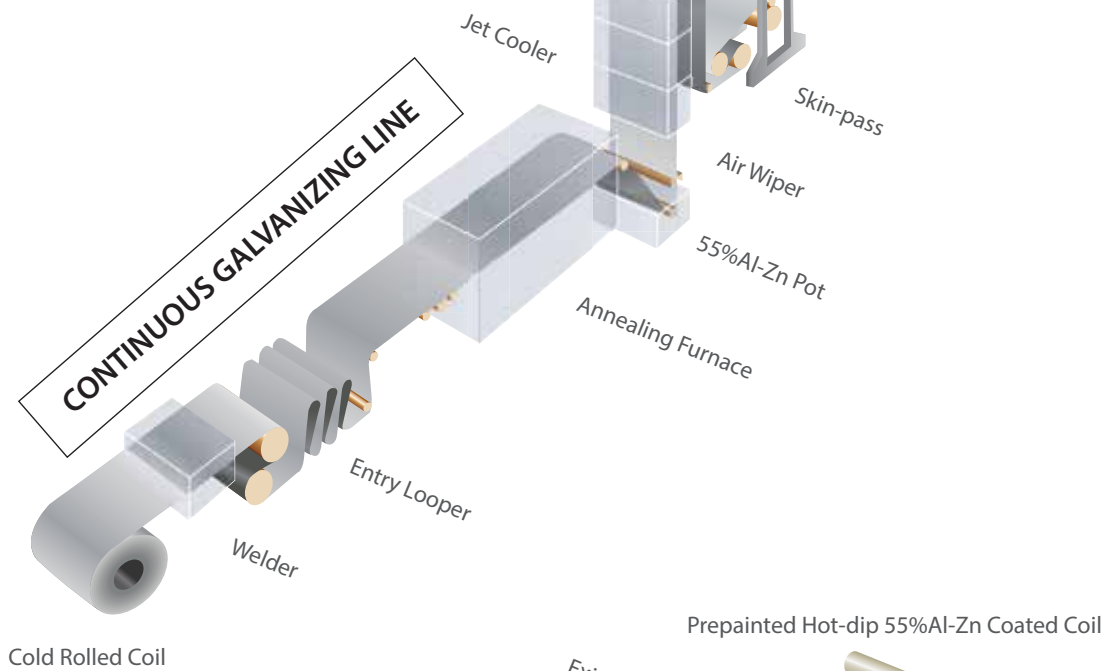

COLOR COATING LINE

MANUFACTURING PROCESS OF COIL PRODUCTS



Push-Pull Pickling Line



6-High Cold Rolling Mill



No.1 Continuous Galvanizing Line



No.2 Continuous Galvanizing Line



Color Coating Line

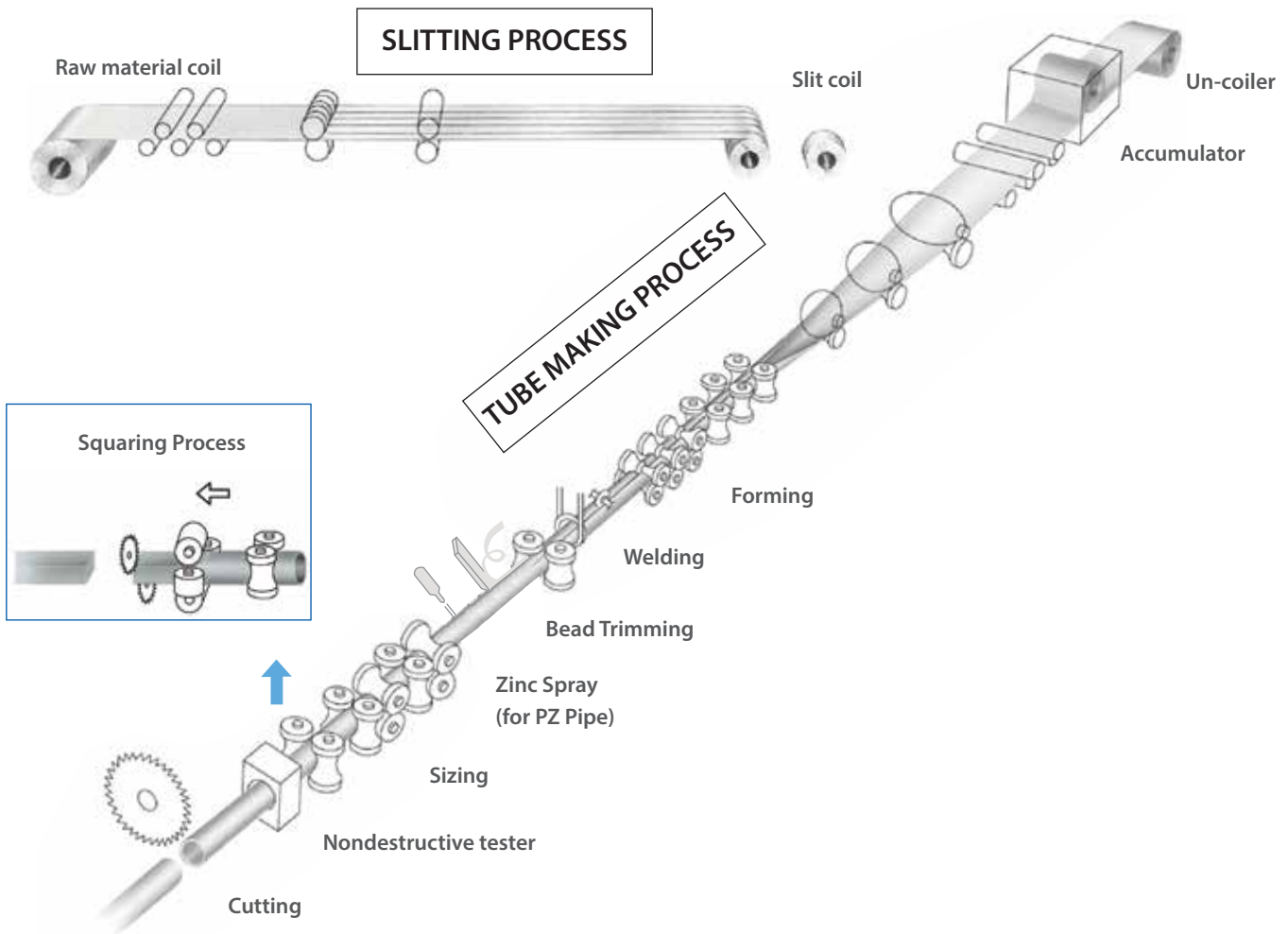

Slitter



Un-coiler



Accumulator



Forming

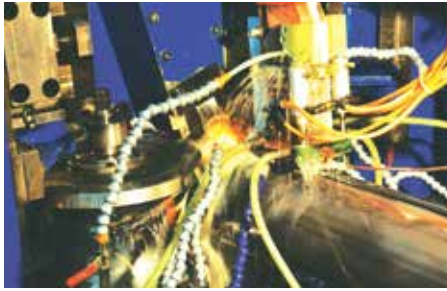

Welding



Ultrasonic tester on 16" pipe mill



Eddy current tester on small pipe mill



Cutting



Facing



Hydrostatic tester

PZ (PRE-ZINC) PIPE



PZ tube mill



Zn spray



Threading

HDG (HOT-DIP GALVANIZED) PIPE

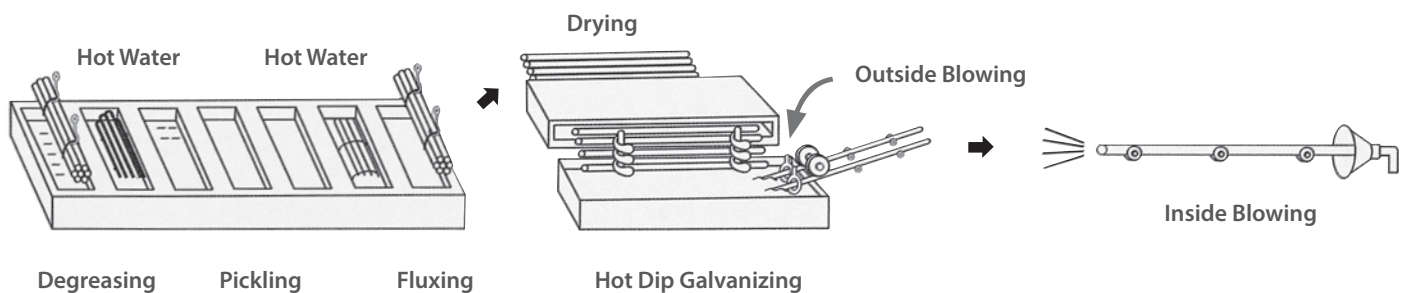

Products Lines	Standard	Available size range		
		Thickness	Standard Width	Coating
Hot-dip galvanized steel strip in coil (GI)	SUNSCOZINC*1 JIS G 3302 ASTM A653	BMT*2 0.25 - 3.2mm 0.008" - 0.125"	914mm 1200mm 1219mm 36" - 48.5"	Z06 ~ Z27 G20 - G90
Hot-dip 55%Al-Zn alloy-coated steel strip in coil (GL)	SUNCOAT55*1 JIS G 3321 ASTM A792 MS 1196 SNI 4096	BMT*2 0.20 - 1.2mm 0.008" - 0.047"	914mm 1200mm 1219mm 36" - 48.5"	AZ50 ~ AZ150 (g/m ²) AZ30 ~ AZ55 (oz/ft ²)
Prepainted hot-dip 55%Al-Zn alloy-coated steel strip in coil (PPGL/SPGL)	SUNCOLOR55 *1 JIS G 3322 MS 2383	BMT*2 0.20 - 1.2 0.008" - 0.047"	914mm 1200mm 1219mm 36" - 48.5"	PPGL Top 18~28μm Back 18 ~ 20μm (2 coat) 5 ~ 15μm (1 coat)
				SPGL Top 10μm Back 5μm

- ※ 1) Our original standard
- ※ 2) BMT; Base Metal Thickness

- SUNCOAT55 & SUNCOLOR55 have superior corrosion-resistance, because 55%Al-Zn coating has both the features of barrier protection of Al and sacrificial protection of Zn.
- Bright coating-spangle of SUNCOAT55 and great color variety of SUNCOLOR55, as well as those superior corrosion-resistance, will surely give the customers much satisfaction.
- Hot-dip 55%Al-Zn coated steel coil is generally applied to roof, wall, inner parts of home electrics and computer and so on.
- Prepainted hot-dip 55%Al-Zn coated steel coil is generally applied to roof, wall, partition, heat insulation and so on.



SUNCOAT55



SUNCOLOR55



Metal Roofing



Metal Wall & Siding Panel



Sandwich Panel



Clean Room Panel

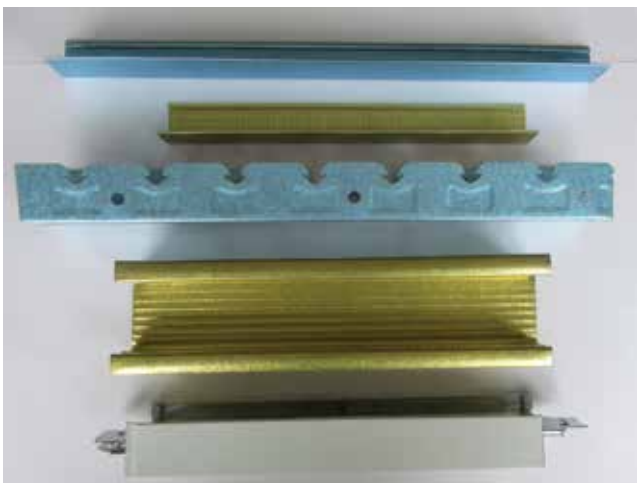

Ceiling / Various Interior Parts

Usage	Cross Section	Standard	Available Size Range
General Structure	○	JIS G 3444 STK	21.7 x 1.4mm ~ 406.4 x 12.7mm
		ASTM A500	5.563" x 0.125" ~ 16.000" x 0.500"
	□ ▭	JIS G 3466 STKR	40 x 40 x 1.6mm ~ 300 x 300 x 12.0mm 60 x 30 x 1.6mm ~ 400 x 200 x 12.0mm
		ASTM A500	4" x 4" x 0.125" ~ 12" x 12" x 0.500" 5" x 3" x 0.125" ~ 16" x 8" x 0.500"
Machine Structure	○	STKM	12.7 x 0.6mm ~ 114.3 x 6.0mm
	□ ▭	STKMR	14 x 14 x 0.8mm ~ 50 x 50 x 3.6mm
Piping	○	JIS G 3452 SGP	15A ~ 400A
		JIS G 3454 STPG	15A x SCH40 ~ 400A x SCH40
		ASTM A53	NPS2 x 0.154" ~ NPS16 x 0.500"
		BS 1387	DN15 x EXTRA LIGHT ~ DN150 x HEAVY
Line Pipe	○	API 5L	5.563" x 0.156" ~ 16.000" x 0.500"
Conduit	○	BS 31	3/4" ~ 2" (PZ)*3
		BS 4568	20mm ~ 32mm (PZ)*3
		ANSI EMT / IMC	1/2" ~ 4" (PZ)*3

※ 3) PZ; Pre-galvanized tube made of hot-dip galvanized steel sheet

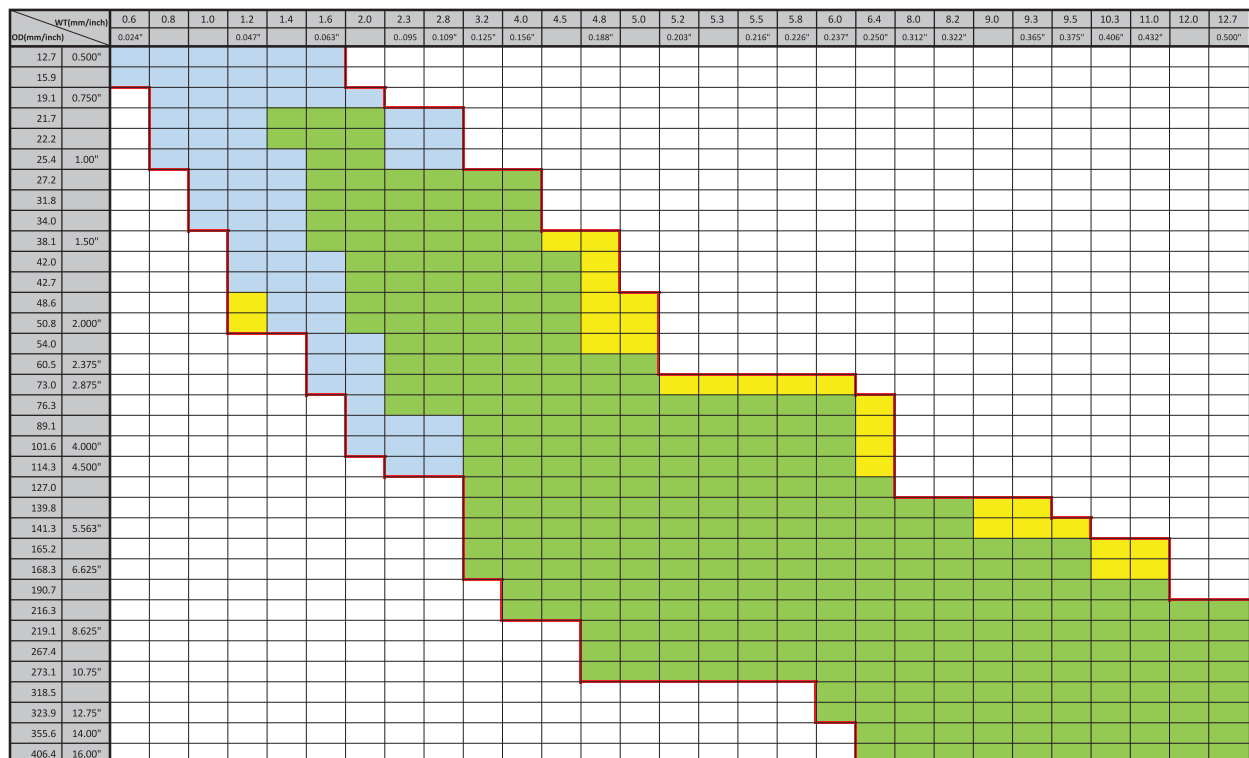

Available Size Range (Round)

Available
 Available with Inner Flash Trimming
 To be discussed



Piping



Line Pipe



Fitting Pipe



Structure



Pipe Pile



Steel Column



Motorcycle parts
(frame, shock absorber, exhaust muffer)



Green House



Scaffolding



Steel Conduit Tube



Furniture



Office Rack



Medical Bed

We, **SUNSCO**, assure and investigate the product's quality with some test equipment.



Tensile tester

Fracture surface after testing



Impact tester

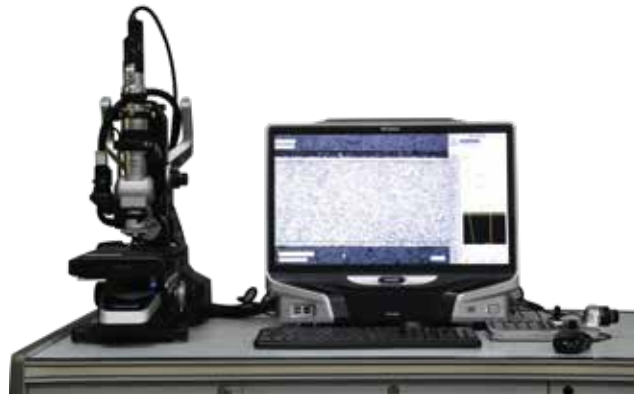

Digital micro scope



Colorimetry tester



Salt spray tester

COIL PRODUCTS SUPPLY RECORD



Project Name: Thuan Phat construction Project - 2017
Standard: SUNCOLOR55 / SPGL G300
Segment: Roof & Wall
Location: Binh Duong Province



Project Name: Brotex (Viet Nam) Project - 2014
Standard: SUNCOLOR55 PPGL G550
Location: Tay Ninh Province
Segment: Roof & Wall



Project Name: Nhà Máy chế biến Bột Mì - 2016
Standard: SUNCOLOR55 / SPGL G300
Segment: Roof & Wall
Location: Tay Ninh Province



Project Name: Sagawa Project - 2016
Standard: SUNCOAT55 G550
Segment: Roof & Wall
Location: Dong Nai Province



Project Name: Tayca (Viet Nam) Project - 2016
Standard: SUNCOAT55 G550
Segment: Roof & Wall
Location: Dong Nai Province



Project Name: AKEBONO Project - 2016
Standard: SUNCOAT55 G550
Segment: Roof & Wall
Location: Hung Yen Province



Project Name: Nippon Paint Project - 2014
Standard: SUNCOLOR55 PPGL G550
Segment: Roof & Wall
Location: Vinh Phuc Province



Project Name: HASHIMA Project - 2016
Standard: SUNCOLOR55 SPGL G300
Segment: Roof & Wall
Location: Hà Nam Province



Project Name: E-Mart (Viet Nam) Project - 2015
Standard: SUNCOLOR55 PPGL G550
Segment: Roof & Wall
Location: HCM City



Project Name: FUJITRANS Project - 2016
Standard: SUNCOLOR55 /SUNCOAT55 G550
Segment: Roof & Wall
Location: Myanmar



Project Name: Tan Son Nhat International Airport Station - Upgrade The Domestic Terminal - 2011
Standard: ASTM A53M Gr.B
Segment: Mechanical System
Location: Tan Binh Dist., HCMC



Project Name: Da Nang City's Administrative Center - 2012
Standard: ASTM A53M Gr.B
Segment: Mechanical System
Location: Da Nang City



Project Name: Vung Ang 1 Thermal Power Project - 2012
Standard: ASTM A53M Gr.B
Segment: Fire fighting system
Location: Ha Tinh Province



Project Name: Vincom Center A Tower Project - 2012
Standard: ASTM A53M Gr.B
Segment: Mechanical System + Fire fighting system
Location: Dist.1, HCMC



Project Name: The National Assembly House - 2013
Standard: ASTM A53M Gr.B
Segment: Mechanical System
Location: Ha Noi City



Project Name: Aeon Mall Tan Phu Project (Aeon No.1) - 2013
Standard: BS 1387-M / JIS G 3452 SGP
Segment: Mechanical System + Fire fighting system
Location: Tan Phu Dist., HCMC



Project Name: Ho Tram Casino Project - 2012
Standard: ASTM A53M Gr.B
Segment: Mechanical System + Fire fighting system
Location: Ba Ria Vung Tau Province



Project Name: Duyen Hai 1 Thermal Power Plant Project - 2014/2015
Standard: ASTM A53M Gr.B
Segment: Water Supply and Drainage
Location: Tra Vinh Province



Project Name: Aeon Mall Long Bien Project - 2014/2015
Standard: JIS G 3452 SGP / ASTM A53M Gr.B
Segment: Mechanical & Electrical
Location: Ha Noi City



Project Name: Vincom Mega Mall Thao Dien - 2015
Standard: ASTM A53M Gr.B
Segment: Mechanical & Electrical
Location: Ho Chi Minh City



Project Name: Samsung HCMC CE Complex - 2015
Standard: JIS G 3466 STKR400
Segment: Flame of Mill
Location: Saigon Hi-Tech Park, Dist.9, HCMC



Project Name: Aeon Mall Binh Duong Project - 2015
Standard: BS1387 / JIS G 3452 SGP
Segment: Mechanical & Electrical
Location: Binh Duong Province



Project Name: Aeon Mall Binh Tan Project - 2015/2016
Standard: BS1387 / JIS G 3452 SGP
Segment: Mechanical & Electrical
Location: Ho Chi Minh City



Project Name: Vinhomes Central Park - Tan Cang Project - 2015/2016
Standard: ASTM A53M Gr.B
Segment: Mechanical & Electrical
Location: Ho Chi Minh City



Project Name: Da Nang International Airport Station Project - 2016
Standard: ASTM A53M Gr.B
Segment: Mechanical & Electrical
Location: Da Nang City



Project Name: Saigon Centre Project - 2016
Standard: ASTM A53M Gr.B
Segment: Mechanical & Electrical
Location: Ho Chi Minh City



Project Name: Ho Chi Minh City Urban Railways
 Project: Ben Thanh - Suoi Tien Section (Line 1) - 2016/2017
Standard: JIS G 3444 STK400
Segment: Flame of station, handrail
Location: Ho Chi Minh City



Project Name: Aeon Mall Phnom Penh Project - 2016/2017
Standard: BS1387/JIS G 3452 SGP/ASTM A53M Gr.B
Segment: Mechanical & Electrical
Location: Phnom Penh



Project Name: Mektec Manufacturing Co.,Ltd Project - Hung Yen - 2017
Standard: BS1387/JIS G 3452 SGP/ASTM A53M Gr.B
Segment: Water Supply and Drainage
Location: Hung Yen Province



Project Name: Vinhomes Golden River (Vinhomes Ba Son) Project - 2017
Standard: ASTM A53M Gr.B
Segment: Mechanical & Electrical
Location: Ho Chi Minh City



MARUICHI SUN STEEL (HANOI) CO., LTD. (SUNSCO/HANOI), a 100% subsidiary company of MARUICHI SUN STEEL JOINT STOCK COMPANY (SUNSCO), being established in 2008 and start its operation in 2010.

Our policy is to produce & supply the Japanese Quality Tube Products to the customers in Vietnam. To do so, we have adopted equipments and quality control systems from MARUICHI STEEL TUBE LTD., who is the No.1 shareholder in the welded steel tube market in Japan and is the major shareholder of SUNSCO.

Now, we produce our steel tubes with following specifications.

- STK (Carbon steel tubes for general structure)
- STKR (Carbon steel square and rectangular tubes for general structure)
- STKM (Carbon steel tubes for machine structure)
- STKMR (Carbon steel square and rectangular tubes for machine structure)
- STAM (Electric resistance welded carbon steel tubes for automobile)
- SGP (Carbon steel pipes for ordinary piping)

Apart from those standard quality tube products we also produce special quality tube products which are to be used for Automobile, Motorbike, and Furniture etc, if inquired.

SUNSCO/HANOI wishes to have support, guidance and cooperation from all the customers in Vietnam and our products to be accepted with satisfaction.

Address: Binh Xuyen Industrial Zone, Huong Canh Town, Binh Xuyen District,
Vinh Phuc Province, Vietnam

Tel: (+84) 211-3582877

Fax: (+84) 211-3582868

Email: sunsteel-hanoi@maruichisunsteel.com

<http://www.maruichisunsteel.com/>

Round tube (STK, STKM, STAM, SGP)

		0.6	0.8	1.0	1.2	1.4	1.6	1.8	2.0	2.3	2.6	2.8	3.2	3.5	3.8	4.0	4.2	
Outside Diameter: D (mm)	15.9	Yellow	White	White	White	White	White	White	White	White	White	White	White	White	White	White	White	White
	17.3	Yellow	White	White	White	White	White	White	White	White	White	White	White	White	White	White	White	White
	19.1	Yellow	White	White	White	White	White	White	White	White	White	White	White	White	White	White	White	White
	21.7	White	Yellow	White	White	White	White	White	White	White	White	White	White	White	White	White	White	White
	22.2	White	White	Green	Green	Green	Green	Green	Green	Green	Green	Green	Green	Green	Green	Green	Green	Green
	25.4	White	White	Green	Green	Green	Green	Green	Green	Green	Green	Green	Green	Green	Green	Green	Green	Green
	27.2	White	White	Green	Green	Green	Green	Green	Green	Green	Green	Green	Green	Green	Green	Green	Green	Green
	28.6	White	White	Green	Green	Green	Green	Green	Green	Green	Green	Green	Green	Green	Green	Green	Green	Green
	29.4	White	White	Green	Green	Green	Green	Green	Green	Green	Green	Green	Green	Green	Green	Green	Green	Green
	31.8	White	White	Green	Green	Green	Green	Green	Green	Green	Green	Green	Green	Green	Green	Green	Green	Green
	34.0	White	White	Green	Green	Green	Green	Green	Green	Green	Green	Green	Green	Green	Green	Green	Green	Green
	35.0	White	White	Green	Green	Green	Green	Green	Green	Green	Green	Green	Green	Green	Green	Green	Green	Green
	38.1	White	White	Green	Green	Green	Green	Green	Green	Green	Green	Green	Green	Green	Green	Green	Green	Green
	41.0	White	White	Green	Green	Green	Green	Green	Green	Green	Green	Green	Green	Green	Green	Green	Green	Green
	42.7	White	White	Green	Green	Green	Green	Green	Green	Green	Green	Green	Green	Green	Green	Green	Green	Green
	45.0	White	White	Yellow	Green	Green	Green	Green	Green	Green	Green	Green	Green	Green	Green	Green	Green	Green
	48.6	White	White	White	Green	Green	Green	Green	Green	Green	Green	Green	Green	Green	Green	Green	Green	Green
	50.8	White	White	White	Green	Green	Green	Green	Green	Green	Green	Green	Green	Green	Green	Green	Green	Green
	54.0	White	White	White	White	Green	Green	Green	Green	Green	Green	Green	Green	Green	Green	Green	Green	Green
60.5	White	White	White	White	Green	Green	Green	Green	Green	Green	Green	Green	Green	Green	Green	Green	Green	
60.8	White	White	White	White	Green	Green	Green	Green	Green	Green	Green	Green	Green	Green	Green	Green	Green	
76.3	White	White	White	White	White	Green	Green	Green	Green	Green	Green	Green	Green	Green	Green	Green	Green	

Square, Rectangular & Oval (STKR, STKMR)

		0.6	0.8	1.0	1.2	1.4	1.6	1.8	2.0	2.3	2.6	2.8	3.2	3.5	3.8	4.0	4.2
Outside Dimension A x B (mm)	32 x 32	White	White	Green	Green	Green	Green	Green	Green	Green	Yellow	Yellow	White	White	White	White	White
	40 x 20	White	White	Green	Green	Green	Green	Green	Green	Green	Yellow	Yellow	White	White	White	White	White
	40 x 25	White	White	Green	Green	Green	Green	Green	Green	Green	Yellow	Yellow	White	White	White	White	White
	50 x 26	White	White	Green	Green	Green	Green	Green	Green	Green	Yellow	Yellow	White	White	White	White	White
	50 x 30	White	White	Green	Green	Green	Green	Green	Green	Green	Yellow	Yellow	White	White	White	White	White
	25 x 55	White	White	Green	Green	Green	Green	Green	Green	Green	Yellow	Yellow	White	White	White	White	White
	50 x 20	White	White	Green	Green	Green	Green	Green	Green	Green	Yellow	Yellow	White	White	White	White	White
	*54 x 20	White	White	Green	Green	Green	Green	Green	Green	Green	Yellow	Yellow	White	White	White	White	White

*54 x 20 (Oval)

Stainless Round Tube (SUS409L)

		1.0	1.2	1.4	1.6	1.8	2.0
Outside Diameter: D (mm)	19.1	Yellow	Yellow	White	White	White	White
	21.7	Yellow	Yellow	White	White	White	White
	22.2	Green	Green	White	White	White	White
	25.4	Green	Green	Yellow	Yellow	White	White
	27.2	Yellow	Yellow	Yellow	Yellow	White	White
	28.6	Green	Green	White	White	White	White
	29.4	Yellow	Yellow	White	White	White	White
	31.8	Yellow	Yellow	White	White	White	White
	34.0	Yellow	Yellow	White	White	White	White
	35.0	Green	Green	White	White	White	White
38.1	Green	Green	Yellow	Yellow	White	White	

- Available
- Available with Inner Flash Trimming
- To be discussed

Profile

SERVING CUSTOMERS THROUGH TUBE MAKING

Maruichi Steel Tube Ltd. and its group companies have been offering customers dedicated services through tube making since its establishment in 1947.

Maruichi Steel Tube Ltd. has been engaged in tube making, amassing technological knowhow and expertise, and having lined up a large number of the latest tube mills, cold reduction and continuous hot-dip galvanizing lines. Those enables company to meet customers' needs for a wide range of round tube's size (from 8mm to 508mm) and similar size of square and rectangular tube (from 11mm × 11mm × 1.0mm to 400mm × 400mm × 19mm).

Our group is one of the very few general steel tube manufacturers in the world that is highly evaluated as a world leader among the welded steel tube industries.

Through our facilities in each regional market in Japan, they are capable of offering good quality products and speedy service to every local customer. We are also serving overseas end users through the affiliates operating in Vietnam, Indonesia, Philippine, China, India, Mexico, and USA.

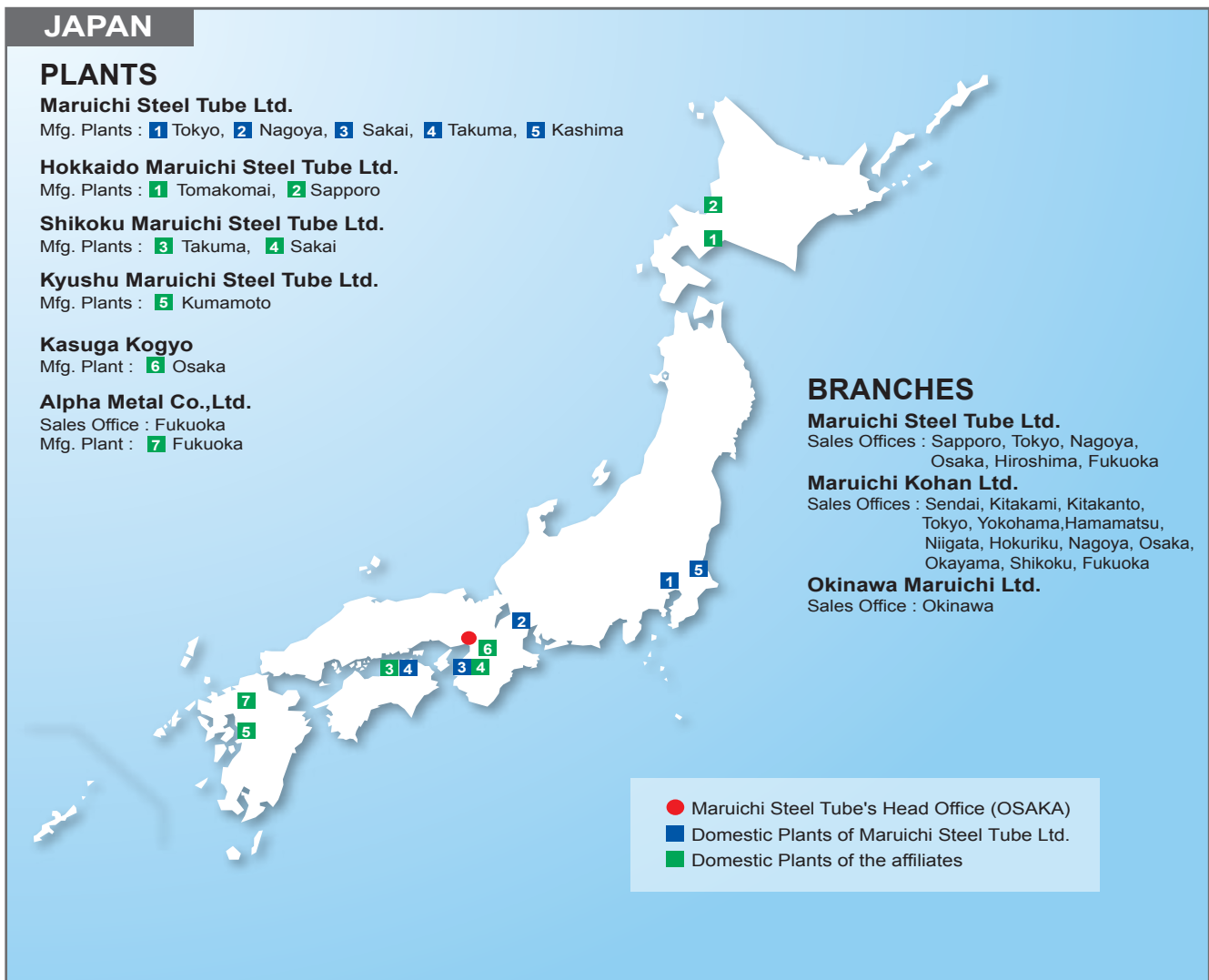

ASIA

- 1 Maruichi Metal Product(Tianjin)Co.,Ltd.**
Zhongnan three street west Tianjin economic development zone area Tianjin City China
- 2 Maruichi Metal Product(Foshan)Co.,Ltd. Wuhan Branch**
No.458 Hannan Avenue, Shamao Town, Hannan District, Wuhan City, Hubei Province, China
- 3 Maruichi Metal Product(Foshan)Co.,Ltd.(MMP)**
Huabao Nan Road, Chengxi Industrial Park, Foshan National HI-TECH Industries Zone, Chancheng District, Foshan City, Guangdong Province, P.R.China
- 4 Maruichi Sun Steel(Hanoi)Co.,Ltd.**
Binh Xuyen Industrial Zone, Binh Xuyen District, Vinh Phuc Province, Vietnam
- 5 Maruichi Sun Steel Joint Stock Company(SUNSCO)**
DT743 Rd., Dong Tac Quarter, Tan Dong Hiep Ward, Di An County, Binh Duong Province, Vietnam
- PT.Indonesia Steel Tube Works(ISTW)**
- 6 Jl. Rawa Sumur I/No.I, Kawasan Industri Pulogadung, Jakarta, Indonesia**
- 7 Jl. Simongan 105, Semarang, Indonesia**
- 8 Maruichi KUMA Steel Tube Private Ltd.**
Plot No.27, Sector 2A, IMT Manesar, Gurgaon-122050(Haryana), India
- 9 Maruichi KUMA Steel Tube Private LTD BANGALORE**
Toyota Tusho Auto Park, Plot No.33&34. Bidadi Industrial Area, Ramanagara Taluk & District,562-109 India
- 10 MARUICHI PHILIPPINES STEEL TUBE INC. (MPST)**
Phase 2B, Block3, Lot2-B, Lima Technology Center, Lipa City, Batangas 4217, Philippines.

NORTH AMERICA

- 11 Maruichi American Corporation(MAC)**
11529 Greenstone Avenue,Santa Fe Springs,CA 90670-4697,U.S.A.
- Maruichi Leavitt Pipe & Tube, LLC(LTC)**
- 12 1717 W 115th Street, Chicago, Illinois 60643, U.S.A.**
- 13 211 Industrial Drive North Madison, Mississippi 39130-1186, U.S.A**
- 14 Maruichi Oregon Steel Tube, LLC(MOST)**
8735 North harborgate Street, Portland, Oregon. 97203-6363, USA
- 15 Maruichimex S.A. de C.V.**
Circuito Japon 112 Parque Industrial San Francisco, San Francisco de Los Romo, Aguascalientes, C. P. 20304, Mexico.



MARUICHI SUN STEEL JOINT STOCK COMPANY (SUNSCO)

DT743 Road, Dong Tac Quarter, Tan Dong Hiep Ward
Di An County, Binh Duong Province, Vietnam

TEL +84 274 374 2777 **TAX CODE** 3700236207
FAX +84 274 374 2223 **EMAIL** info@maruichisunsteel.com

MARUICHI SUN STEEL (HANOI) CO., LTD.

Binh Xuyen Industrial Zone, Huong Canh Town, Binh Xuyen District,
Vinh Phuc Province, Vietnam

TEL: (+84) 211-3582877
FAX: (+84) 211-3582868
EMAIL: sunsteel-hanoi@maruichisunsteel.com

<http://www.maruichisunsteel.com/>