

# Waste Oil Drum

## Installation Instructions

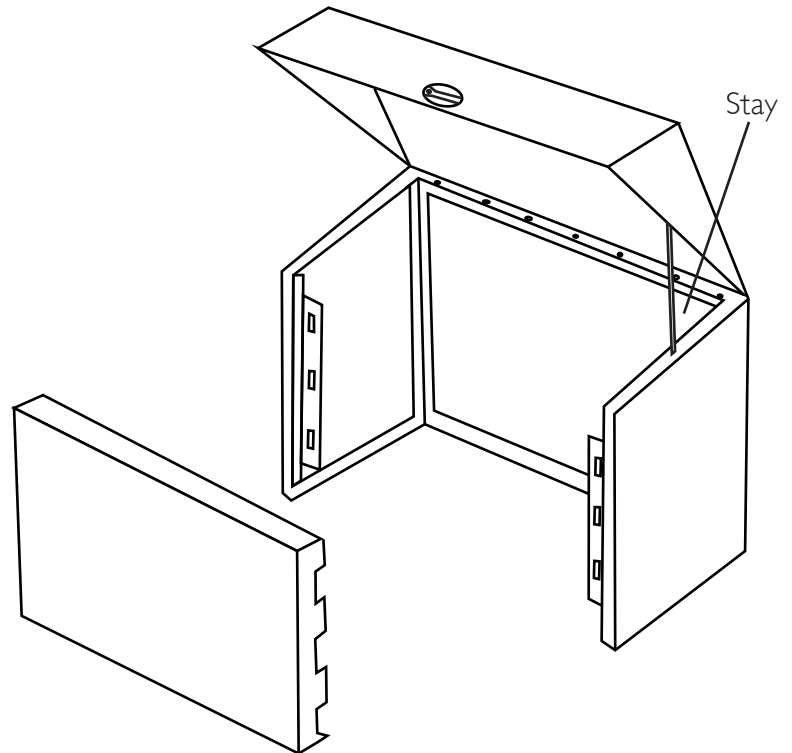
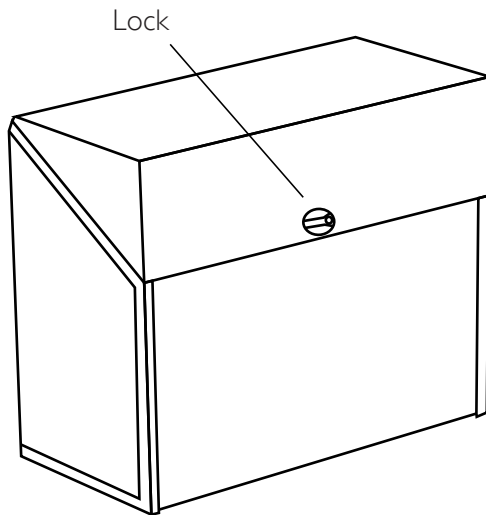

Drum Oil Diagram  
Example shows a waste oil drum cabinet.

### Instructions

1. Remove the front panel by lifting and pulling towards you.
2. There are two sets of four holes in both the base and back of the unit, decide which holes are more appropriate for a secure fixing. Ideally, the two holes in the rear of the top panel and the two in the front base.
3. From inside the cabinet, replace the front panel.
4. With a 10mm masonry drill bit, drill to a depth of no less than 60mm.
5. Push the four sleeve anchor bolts through the holes in the cabinet and into the drilled holes.
6. Hand tighten and tap home with a hammer before tightening fully with a spanner/socket.
7. Remove the front panel, exit the unit and replace.

### Handy Hint

If you can't site directly to a wall or the fixing is weak, drill into the upper part of the cabinet sides and bolt on one or more brackets (wood or metal). To brace the cabinet unit use plain headed coach bolts, this will help prevent removal.