

# HDB SERIES

## Decompression block couplings

### INTRODUCTION

Holmbury's HDB Series is a block coupling designed for the quick changeover of hydraulic attachments for skid steer loaders, compact loaders, backhoe loaders and compact utility vehicles. The decompression feature enables the operator to alleviate trapped pressure, allowing the quick and easy connection of various attachments.

### CONSTRUCTION

- HQ Series couplings are carbon steel with zinc nickel plating (1200 hours with no red rust in salt spray tests)
- Block body is ductile cast iron
- Fitted with Nitrile and PTFE seals

### FEATURES

- Operator friendly decompression system allows for easy connection and disconnection with trapped residual pressure
- Pull activation feature prevents accidental system decompression
- All couplings are flat face and are designed to the ISO 16028 Standard
- Low profile coupling design minimises side loading
- Coupling arrangement can be ordered in 1/2" (Size 12) for standard flow or 3/4" (Size 19) for high flow applications
- Case drain coupling is standard 3/8" (Size 10)
- Low cost replacement couplings
- Accessible design allows for servicing of internal components

### ORDER CODES



### SPECIFICATIONS

- Operating temperatures (With Nitrile seals): -40°C (-40°F) to 106°C (223°F).
- Maximum working pressure 350 bar
- Flow rate at 2 bar delta P 1/2" (size 12) 76.4 L/Min & 3/4" (size 19) 136 L/Min
- Decompression force 130 Nm at 275 bar trapped pressure

### APPLICATIONS

- Quick changeover of construction equipment attachments
- Skid steer loaders
- Track loaders
- Excavators
- Compact loaders
- Utility vehicles

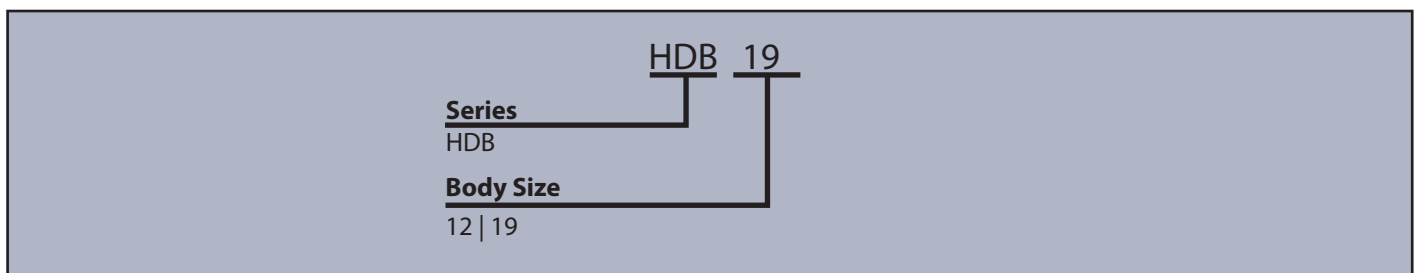

## DRAWING & DIMENSIONS

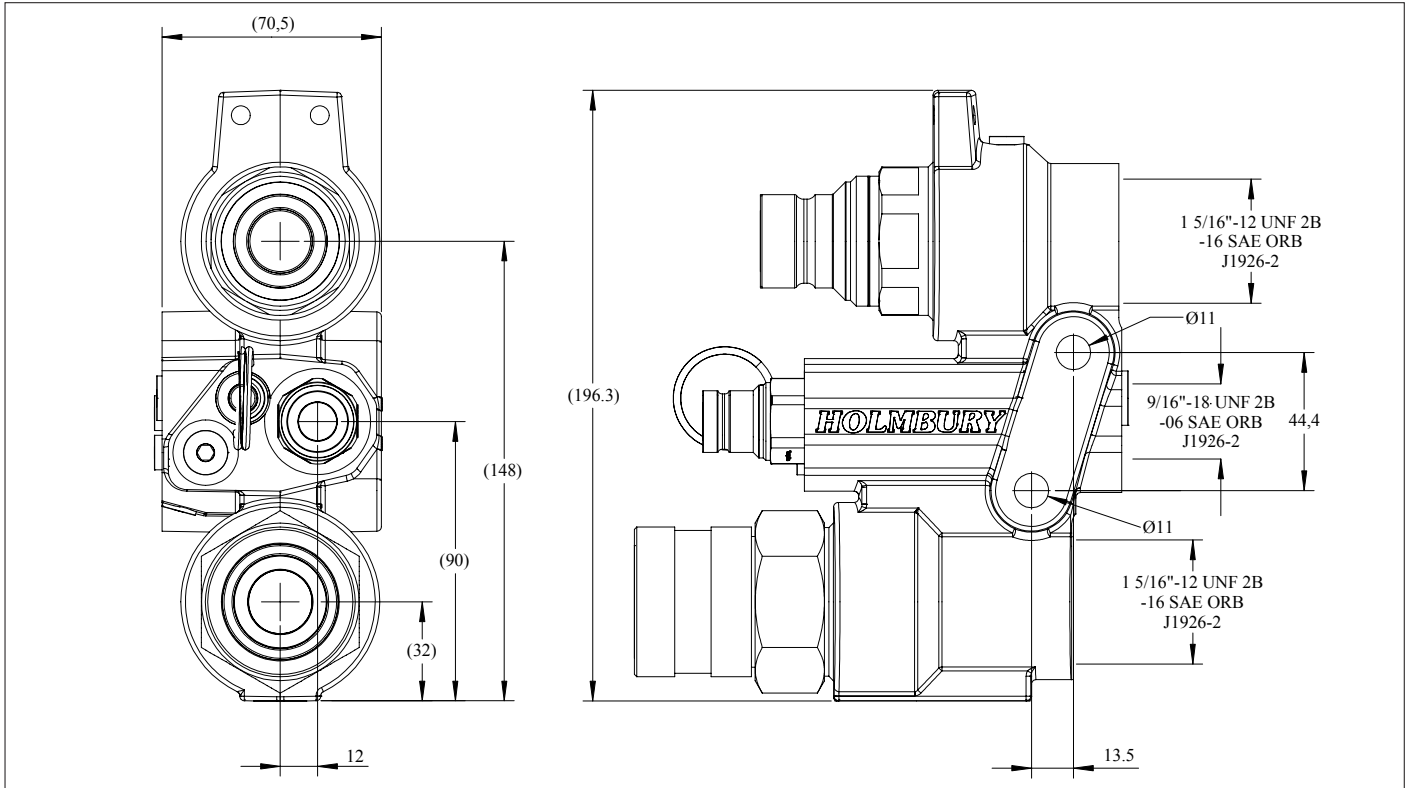

## PRESSURE DROP CHARACTERISTICS

