

3-Phase Stepping Motor Driver

# 3M2060

## OPERATING MANUAL

### Table of contents

---

➤ <b>Introduction</b>	page 2
<hr/>	
➤ <b>Specifications</b>	page 2
Timing chart	page 3
<hr/>	
➤ <b>Setting</b>	page 4
Current set	page 4
Reduce current function	page 4
Micro-Steps	page 5
<hr/>	
➤ <b>Connection</b>	page 6
Control signal	page 6
Power supply and Stepping-Motor connect	page 8
<hr/>	
➤ <b>Troubleshooting</b>	page 9
<hr/>	
➤ <b>Dimension</b>	page 10

---

---

# Introduction

This product is a high-performance micro-stepping driver.

- **Smooth driver**  
By using micro-stepping, this driver can achieved low-vibration and low-noise.
- **Built-in overheat protection**  
A driver's internal temperature in excess of 70°C (158°F) trigger overheat protection, and the driver will stop working automatically.
- **Adjustable operating current**  
A digital switch adjusts the level of motor current during operation.
- **Automatic reduce current**  
In the stop state, the driver will reduce the current automatically to limit the heat generated by the motor and driver.

## Specifications

	Min	Typical	Max
Supply Voltage (VAC)	80	110	220
Output Current ( $A_{rms}$ )	1.3	-	5.6
Logical Input Current (mA)	7	15	16
Input Frequency (KHz)	0	-	200
Low-Active Required Time	2.5	-	-

Operation Environment	Ambient temperature	0 to +65°C (+32 to +149°F) (non-freezing)
	Humidity	80% or less (non-condensing)
	Surrounding atmosphere	No corrosive gas, dust, water or oil
Storage Environment	Ambient temperature	-10 to +80°C (+14 to +176°F) (non-freezing)
	Humidity	80% or less (non-condensing)
	Surrounding atmosphere	No corrosive gas, dust, water or oil
Vibration	5.9 m/s <sup>2</sup> or less	
Mass	1.5 Kg	

- **Timing chart**

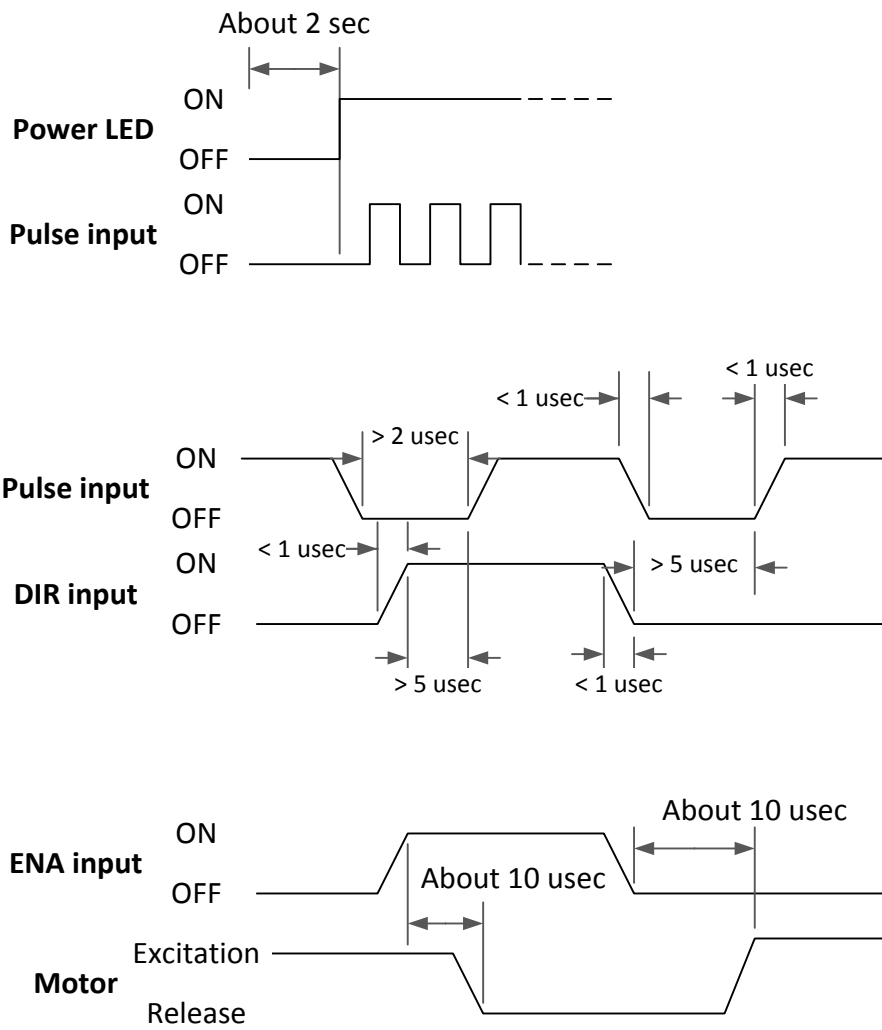

# Setting

By switching the following DIP-SWITCH, user can change the output current and micro-steps of driver.

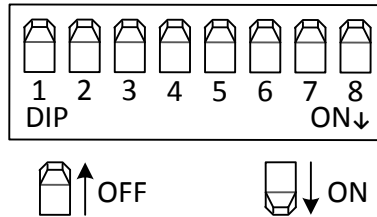

- **Current Set**

SW 1	SW 2	SW 3	Current (A <sub>rms</sub> )
OFF	OFF	OFF	1.3 A
<b>ON</b>	OFF	OFF	1.8 A
OFF	<b>ON</b>	OFF	2.5 A
<b>ON</b>	<b>ON</b>	OFF	3.1 A
OFF	OFF	<b>ON</b>	3.7 A
<b>ON</b>	OFF	<b>ON</b>	4.3 A
OFF	<b>ON</b>	<b>ON</b>	5.0 A
<b>ON</b>	<b>ON</b>	<b>ON</b>	5.6 A

- **Reduce Current Function**

SW 4	Function
<b>ON</b>	Maintain full current in the stop state
OFF	Automatically reduce current in the stop state

---

- **Micro-Steps (for 1.2° basic step)**

SW 5	SW 6	SW 7	SW 8	Steps/Rev
OFF	OFF	OFF	OFF	200
<b>ON</b>	OFF	OFF	OFF	400
OFF	<b>ON</b>	OFF	OFF	500
<b>ON</b>	<b>ON</b>	OFF	OFF	800
OFF	OFF	<b>ON</b>	OFF	1000
<b>ON</b>	OFF	<b>ON</b>	OFF	1250
OFF	<b>ON</b>	<b>ON</b>	OFF	1600
<b>ON</b>	<b>ON</b>	<b>ON</b>	OFF	2000
OFF	OFF	OFF	<b>ON</b>	2500
<b>ON</b>	OFF	OFF	<b>ON</b>	3200
OFF	<b>ON</b>	OFF	<b>ON</b>	4000
<b>ON</b>	<b>ON</b>	OFF	<b>ON</b>	5000
OFF	OFF	<b>ON</b>	<b>ON</b>	6400
<b>ON</b>	OFF	<b>ON</b>	<b>ON</b>	8000
OFF	<b>ON</b>	<b>ON</b>	<b>ON</b>	10000
<b>ON</b>	<b>ON</b>	<b>ON</b>	<b>ON</b>	12800

# Connection

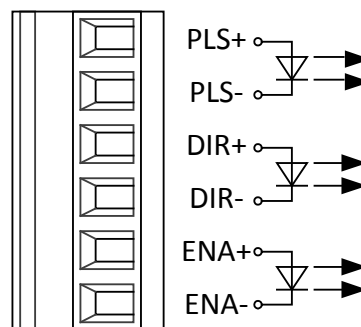

- Control signal**

This terminal is used for control signal.

This driver only accepts pulse/dir type signal (1-pulse input type).

PLS+	Photo-couple Positive	-
PLS-	Pulse signal input	Motor will run one micro-step when driver receive one pulse. Low-Active, the internal resistor is 270Ω ◦ Logical low is 0 ~ 0.5V ; Logical high is 4 ~ 5V. Signal width must be larger than 2.5 usec.
DIR+	Photo-couple Positive	-
DIR-	Direction signal input	Decide the rotational direction. The internal resistor is 270Ω ◦ Logical low is 0 ~ 0.5V ; Logical high is 4 ~ 5V. Signal width must be larger than 2.5 usec.
ENA+	Photo-couple Positive	-
ENA-	Free signal input 	When this input be activated (Low-Active), the driver will shut off the output current and the motor will lose its excitation holding torque. This, however, will allow you to adjust the load position manually. Low-Active, the internal resistor is 270Ω ◦ Logical low is 0 ~ 0.5V ; Logical high is 4 ~ 5V. Signal width must be larger than 2.5 usec.

## NOTE

For control signal input, 5 VDC can be directly connected and applied. If signals are used at a voltage above 5 VDC, be sure to connect an external resistor to prevent the current from exceeding 16 mA. Applying a voltage beyond 5 VDC without using an external resistor will damage the internal elements.

Example:

R=0, when using 5 VDC;

R=1k and > 1/8W, when using 12 VDC;

R=2k and > 1/8W, when using 24VDC.

▼ Example of connection with a current sink output circuit

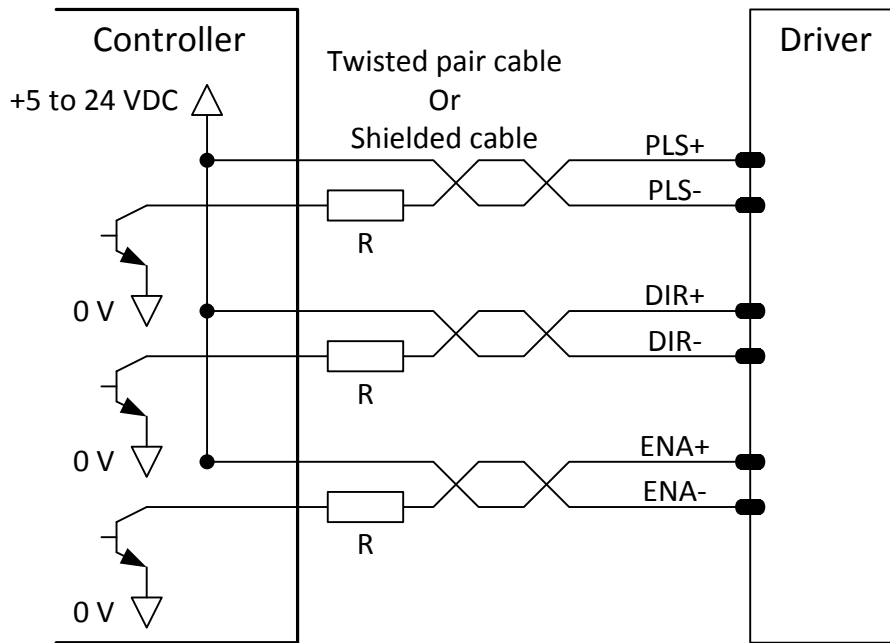

▼ Example of connection with a current source output circuit

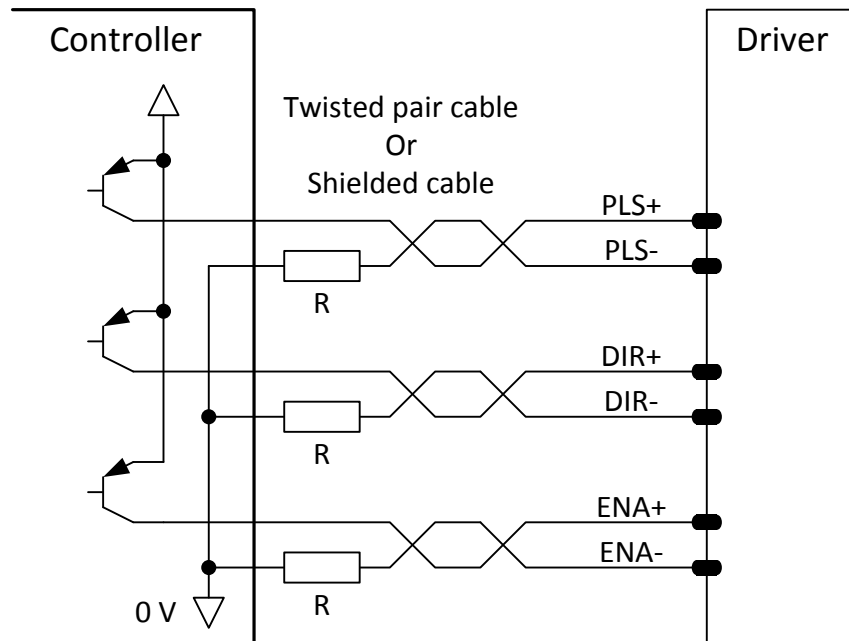

- **Power supply and Stepping-Motor connect**

This terminal is used for supply the motor and driver power. **Be careful not to touch the live connections.**

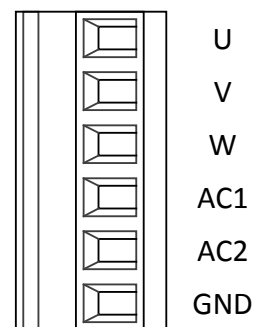

AC1	Power Input Line1	The input power must be between 80VAC to 220VAC.
AC2	Power Input Line2	
GND	Ground	Power Ground.
U	Motor Phase U Line	Connect the motor wires as defined.
V	Motor Phase V Line	
W	Motor Phase W Line	



---

# Troubleshooting

When the motor cannot be operated correctly, refer to the contents provided in this section and take appropriate action. If the problem persists, contact your nearest office.

Phenomenon	Possible cause	Remedial action
The motor is not excited. The motor's output shaft can be turned easily with the hands. (The motor equipped with an electromagnetic brake can be turned easily with the hands, once the brake is released.)	Bad connection of the motor cable.	Recheck the connections between the motor and driver. Take appropriate action and turn on the power again
	Incorrect setting of the current-adjustment switch.	Check the rated current of motor and set the switch to rated current of motor.
	ENA input is active.	Dis-active the ENA signal.
	Overheat protection is active.	Shut off the driver's power and check the cause of the problem that had triggered overheat protection. Take appropriate action and turn on the power again

# Dimension

