

# **FLUID POWER**

## **FLUID POWER EQUIPMENT**

### **TUTORIAL – DIRECTIONAL CONTROL VALVES**

This work covers part of outcome 2 of the Edexcel standard module:

#### **UNIT 21746P APPLIED PNEUMATICS AND HYDRAULICS**

The material needed for outcome 2 is very extensive so the tutorial is presented as a series.

<b>OUTCOME 2</b>  Investigate the construction and operation of pneumatic and hydraulic components, equipment and plant.	<ul style="list-style-type: none"><li>• Identify and describe the features of pneumatic and hydraulic equipment.</li><li>• Analyse the performance characteristics of pneumatic and hydraulic equipment.</li></ul>
--	--

The series of tutorials provides an extensive overview of fluid power for students at all levels seeking a good knowledge of fluid power equipment.

On completion of this tutorial you should be able to do the following.

- Explain the principles and symbols of directional control valves.
- Explain the different port configurations of directional control valves.
- Explain the different ways valves are moved.
- Describe the construction of different types of directional valves.
- Explain the importance of standard valve bases and manifolds.

## DIRECTIONAL VALVES

### 1. INTRODUCTION

Valves are necessary to control the pressure, flow rate and direction of the fluid. Hydraulic valves are made to a high standard of quality and robustness. The diagram shows a few of the vast range of hydraulic valves available. We should remember always that hydraulic systems are high pressure systems and pneumatic systems are low pressure systems. Hydraulic valves are made of strong materials (e.g. steel) and are precision manufactured. Pneumatic valves are made from cheaper materials (e.g. aluminium and polymer) and are cheaper to manufacture.

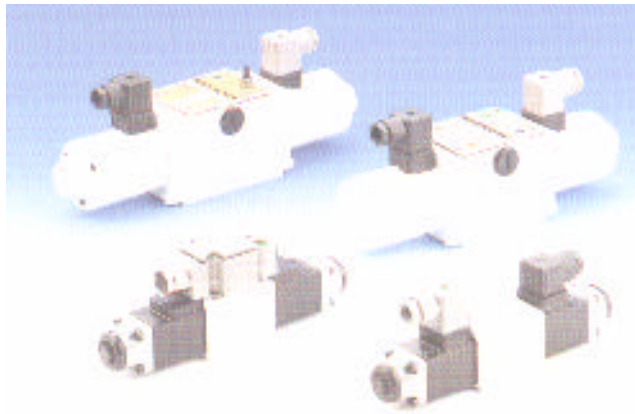

Figure 1

We will start by considering how the fluid is directed from the pump/compressor to the actuator and back to the tank/atmosphere. Consider the basic circuit below.

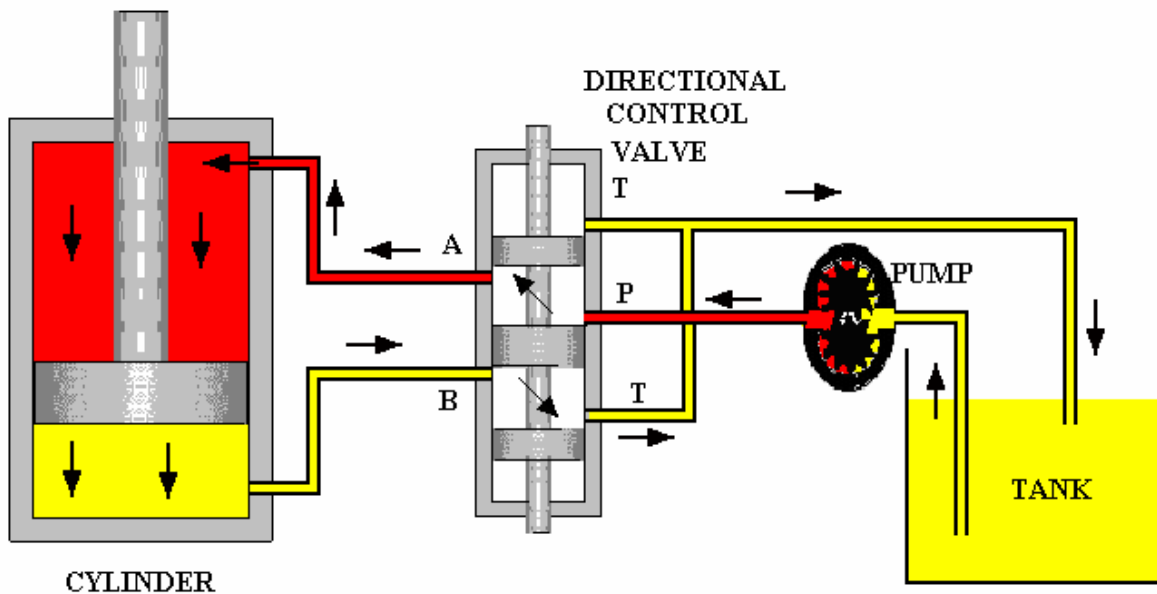

Figure 2

The directional control valve must direct the flow from the pump either to port A or port B. The oil being exhausted by the cylinder must be directed from the other port back to tank. The number of ports (external connections) and the number of positions describe such valves.

The valve shown has 5 ports and 3 positions so it is designated as a **5/3 directional control valve**.



The basic symbol for a valve is a rectangle to which external connections are drawn. Inside the rectangle, the internal connections are shown for the normal position of the valve. Extra boxes show the internal connections for the other positions of the valve.

Figure 3 shows a 4/2 valve and matching symbol to BS2917. In hydraulics the pressure port is designated P and the return port R or T (for tank). The two other ports are designated A and B. In Pneumatics the pressure port is numbered (1) and the exhaust port (3). The other two are numbered (2) and (4). Note how in the normal position P connects to B and A to T. In the operated position P is connected to A and B to T thus reversing the flow directions at A and B.

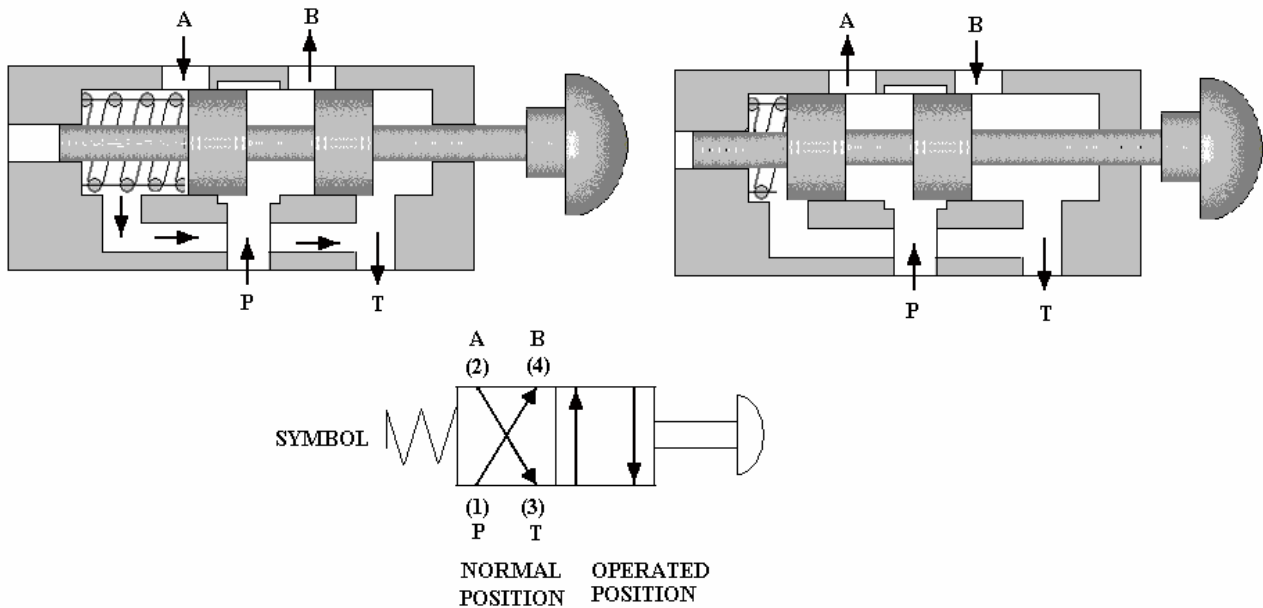

Figures 3

The left box of the symbol shows the connections for the normal position. The right box shows the connections when the spool is moved to the left. The identification tags A, B, P and T are placed against the normal position of the valve. Note this particular valve has a push button to operate it and a spring to return it to the normal position. This is also shown on the symbol.

If the valve has a neutral position such that nothing is supplied to neither A nor B, then a third rectangle is inserted in the middle of the symbol (fig.4). The valve is then a 4/3 valve. There are various ways the ports may be connected in the middle position for various reasons. In fig.4 they are all shown blocked off.

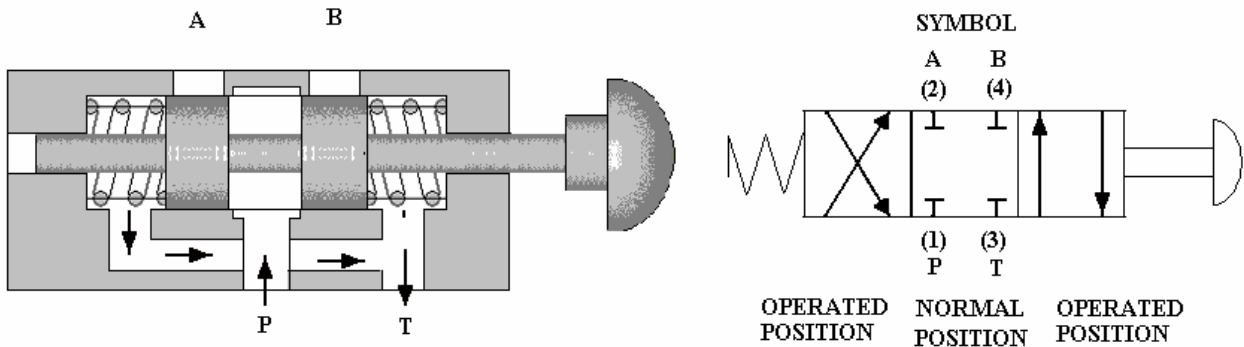

Figure 4

When the P connection is blocked off the valve is said to have a closed centre. A slight modification as shown in figure 5 allows all the ports to be joined in the centre position. When P is connected to T in the middle position, it has an open centre. This allows the pump to vent to tank in the neutral position so saving energy and wear and tear on the pump. The disadvantage of an open centre is that you lose the system pressure so nothing else can be used from with pump.

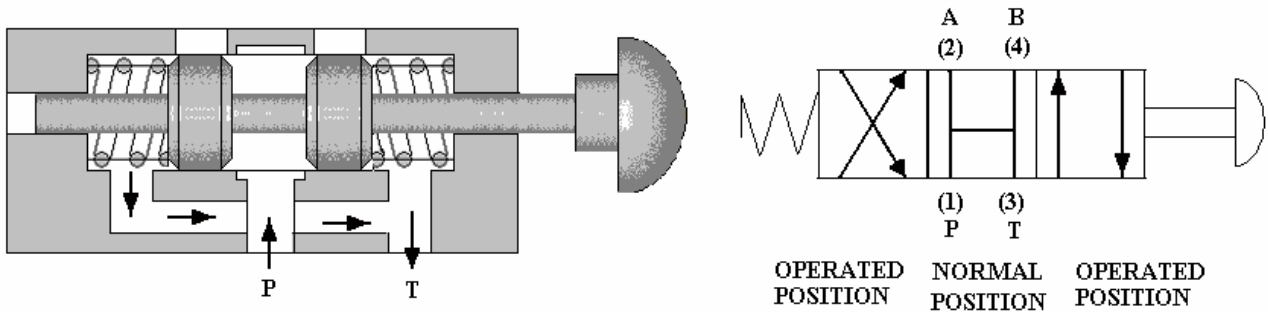

Figure 5

Besides showing the internal connections, a valve symbol must show how the valve element is moved. This is done by adding a small box at each end containing the symbol showing how it is done. Some examples are shown below.

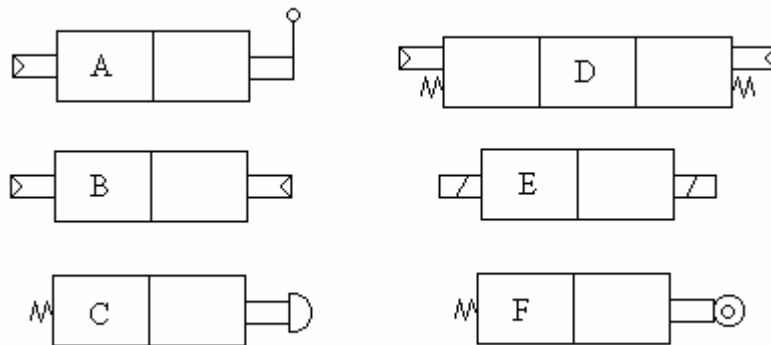

Figure 6

- A Hand lever operated and pilot return.
- B Pilot operated and pilot return.
- C Push knob operated and spring return.
- D 3 position valve pilot/pilot with spring centring.
- E Solenoid operated and solenoid return.
- F Roller operated and spring return.

## 2. VALVE BASES

Directional and other valves are usually designed to be mounted on a separate base. The external pipe work is connected to the base. The advantage of this is standardisation of designs and it allows the valve to be removed without disconnecting the pipe work. Hydraulic bases to ISO size 6 and 10 are shown below.

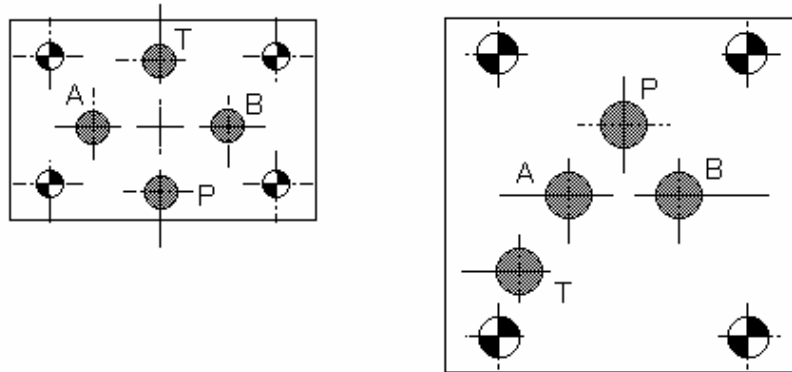

Figure 7

Machines used in industrial applications use several valves and it is convenient to mount them on a manifold so that supply and exhaust connections are common to all. This is a common design for air valves.

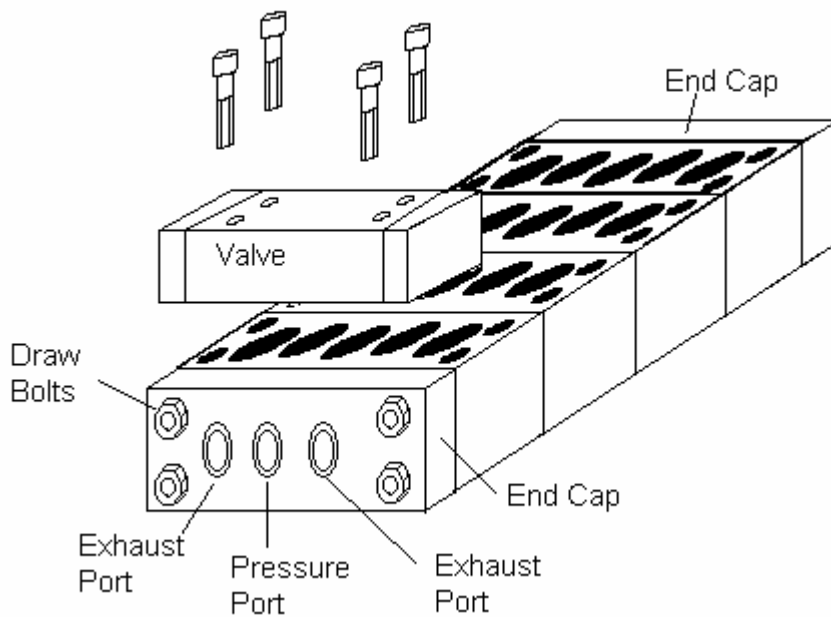

Figure 8

## 3. OTHER DESIGNS.

## POPPET VALVES

The directional control valves so far studied are all of the type that uses a sliding piston or spool. Other designs use flat plates and poppets but the functions are the same although they may not be as robust and are more suited to pneumatics. Poppets make take the form of a ball, a flat plate or a cone. The diagram shows a 3/2 poppet valve. In the position shown P is connected to A. When a force is applied the poppet moves to the other position and flow is from A to T.

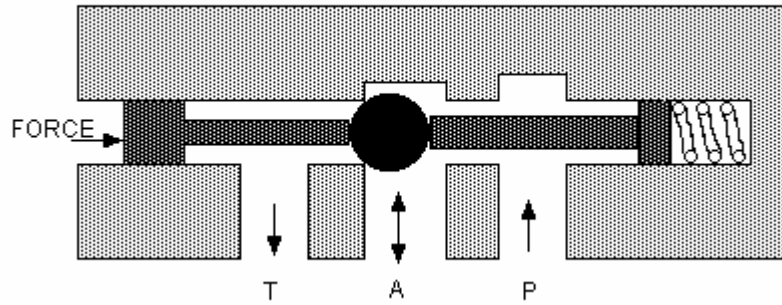

Figure 9

The diagram below shows a 5/2 poppet valve. This is more common for pneumatics than hydraulics.

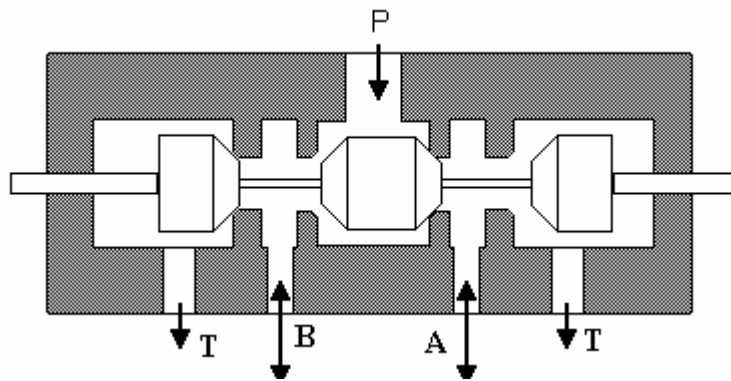

Figure 10

## ROTARY VALVES

The diagram shows a cross section through 4/3 valve. When the element is rotated about its axis, the passages A, B ,P and T are connected as shown.

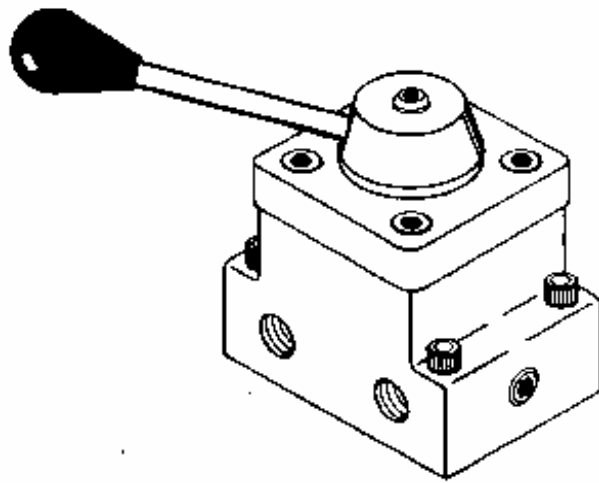
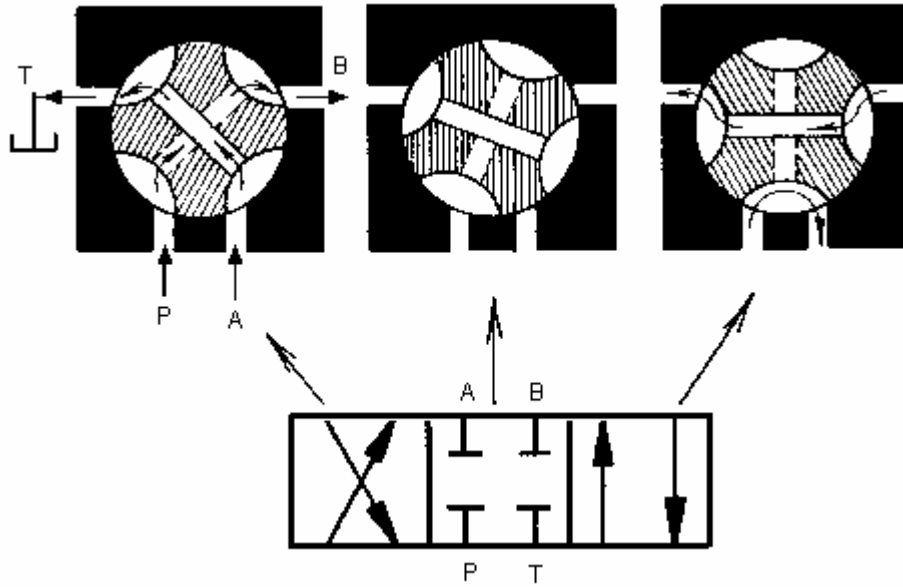

Figure 11



## CARTRIDGE VALVES

These are forms of poppet valve designed to fit into a manifold block. Just about all valve types can be designed as a cartridge to fit into a block specially machined to accept it. In this way a bank of valves may be built into one block. The block might contain directional valves, relief valves, flow dividers, one way valves and so on.

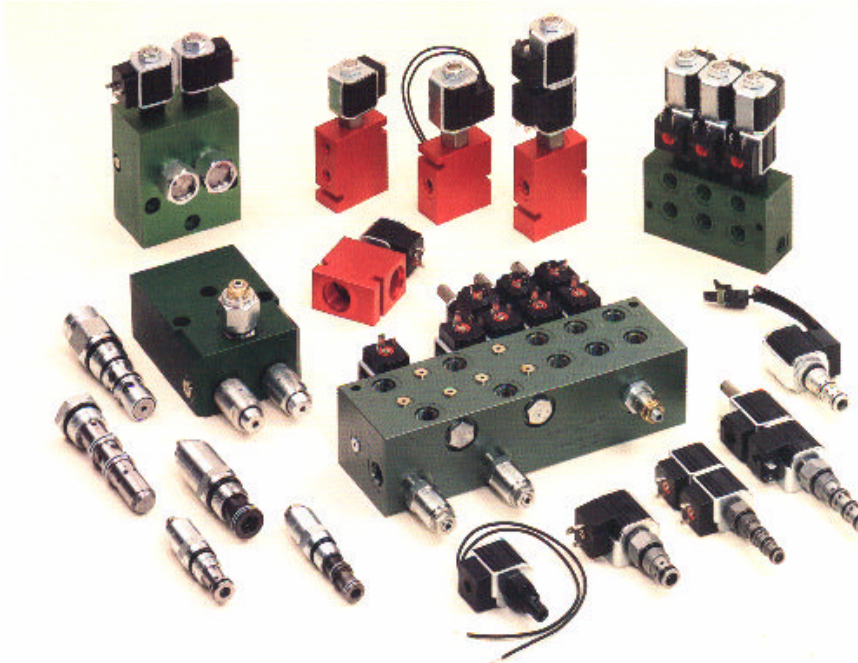

Figure 12

The directional valves are in the main pilot/solenoid operated. The next diagram shows a 2 way normally closed design. In the de-energised state, the pressure forces the poppet closed against the valve seat. When the solenoid is energised, the pilot poppet is lifted up venting the pressure on top of the main poppet so allowing it to be pushed upwards by the system pressure and opening the passage through the valve seat.

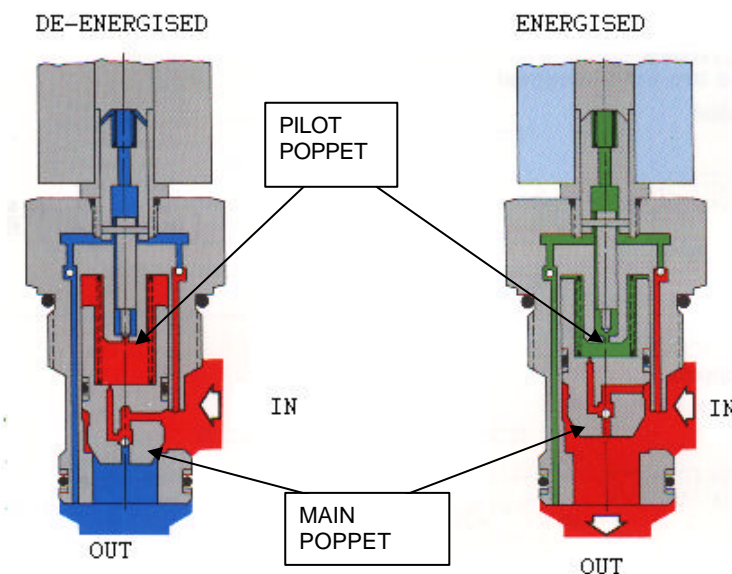

Figure 13

## 4. METHODS OF OPERATING DIRECTIONAL VALVES

### 4.1 PILOT OPERATED VALVES

The diagram below shows a pneumatic 3 port valve, pilot operated and spring returned. The pressure port (1) is normally open to the cylinder port (2) and the valve must be operated to turn the pressure off. This valve is said to be Normally Open.

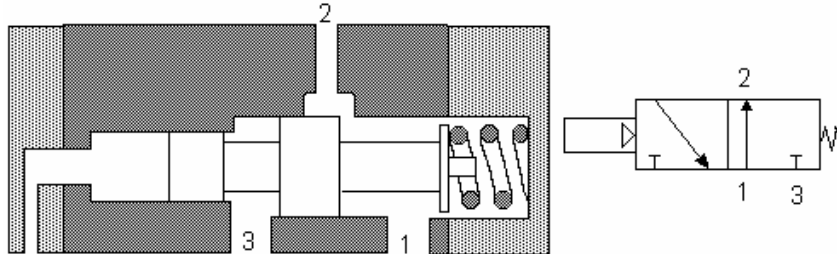

Figure 14

By simply reversing ports (1) and (3) the pressure port is normally closed and the valve is operated to obtain pressure at port (2). This valve is Normally Closed.

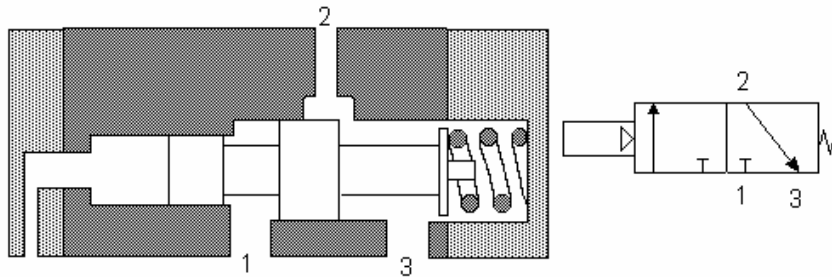
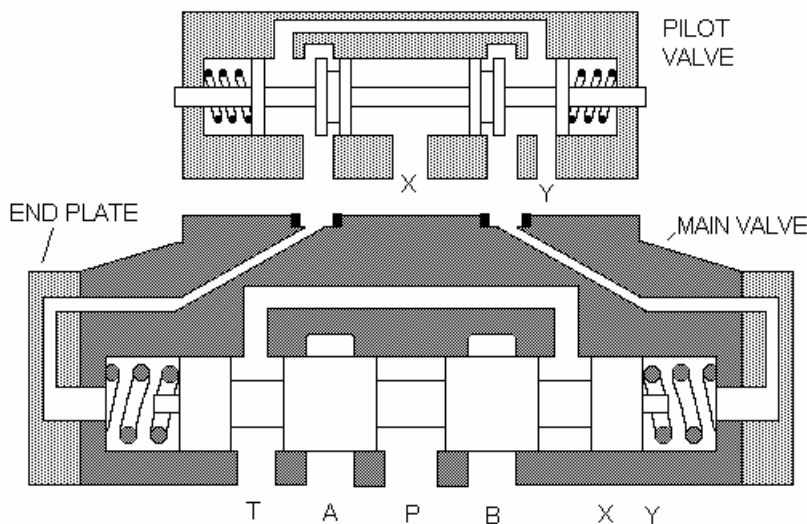

Figure 15

The diagram shows a modern hydraulic pilot operated valve. The main valve has 6 ports on the base, A, B, P, T, X and Y.



P and T are the pressure and tank connections for the main valve which may have any spool configuration but the one shown is a 4/3 closed centre and it is spring centred. X and Y are the pressure and tank connections for the pilot valve which are brought through the main body to the underside. The pilot connections are made via end plates. The pilot valve is most likely to be solenoid operated with solenoid assemblies on one or both ends.

Figure 16

The circuit shows a typical pneumatic circuit with pilot operation. If the lever on the left hand valve is operated air is sent from port 2 to port 14. The DCV operates and air is sent from port 1 to port 2 and the cylinder extends. If the right hand lever is operated air is sent to port 12 and the DCV reverses sending air to port 4 and the cylinder retracts.

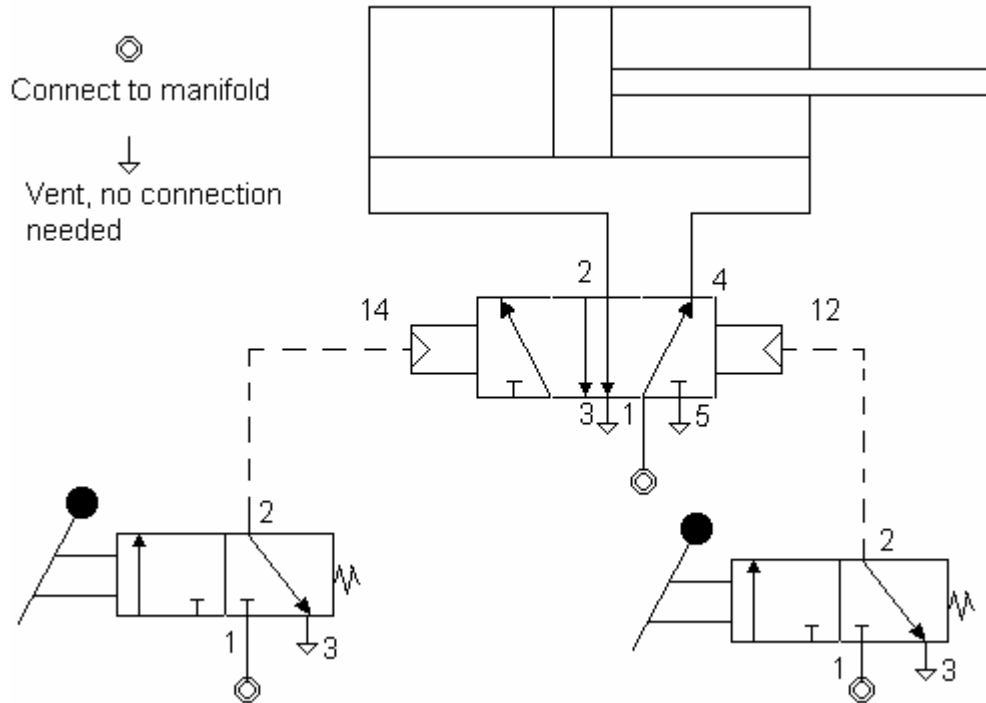

Figure 17

## 4.2 SOLENOID OPERATED VALVES

### SOLENOIDS

A solenoid is a coil with an iron plunger inside it. When current flows in the coil, the plunger becomes magnetised and tries to move out of the coil. If a spring is used to resist the movement, the distance moved is directly proportional to the current in the coil. Solenoids are used in relays where they operate an electric switch. They are also used in hydraulic and pneumatic valves to move the valve element.

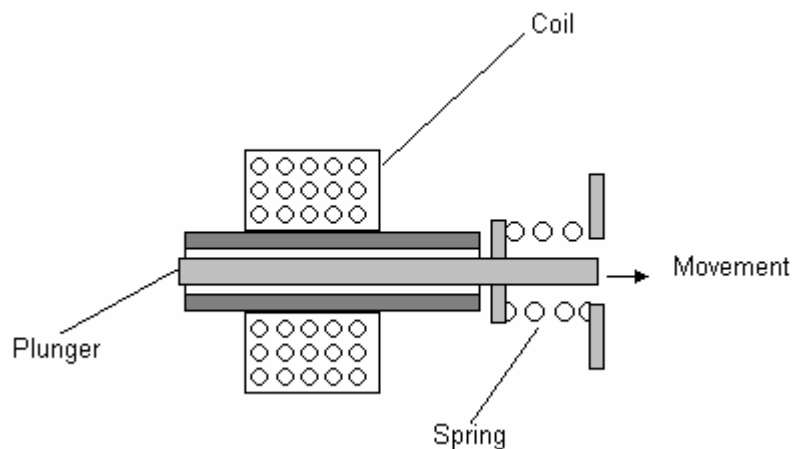

Figure 18

A direct acting solenoid valve would have the plunger pushing directly on the valve element as shown. This is more common in pneumatic valves.

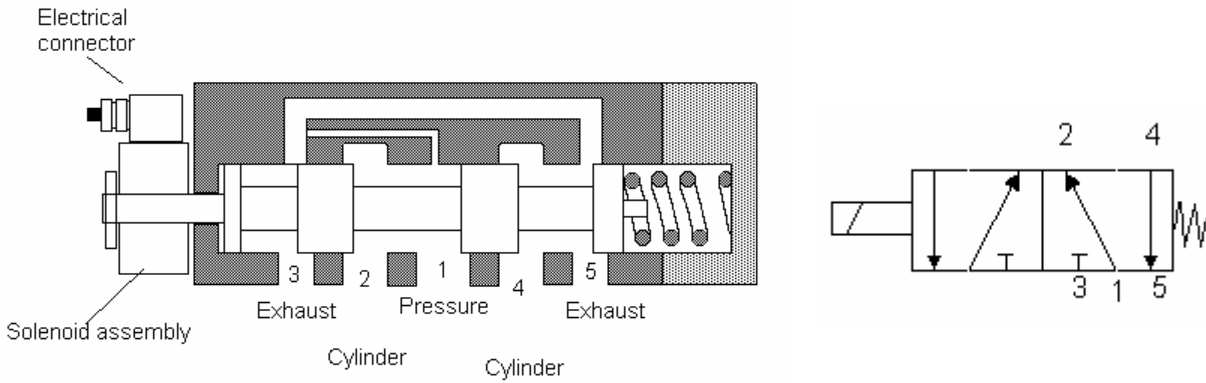

Figure 19

Often the valve may be manually operated by pushing the plunger with a screw driver or by turning a screw on the side. This is very useful when checking to see if the valve has stuck.

Modern solenoid valves are really pilot valves. A second small electrically operated poppet valve is fitted at the end which lets oil/air through to the end of the piston and so pilot operates them. The valve shown is a pneumatic solenoid/poppet operated and spring return. When the solenoid is activated, the valve switches. When the solenoid is deactivated, the valve switches back; hence it is a two position valve.

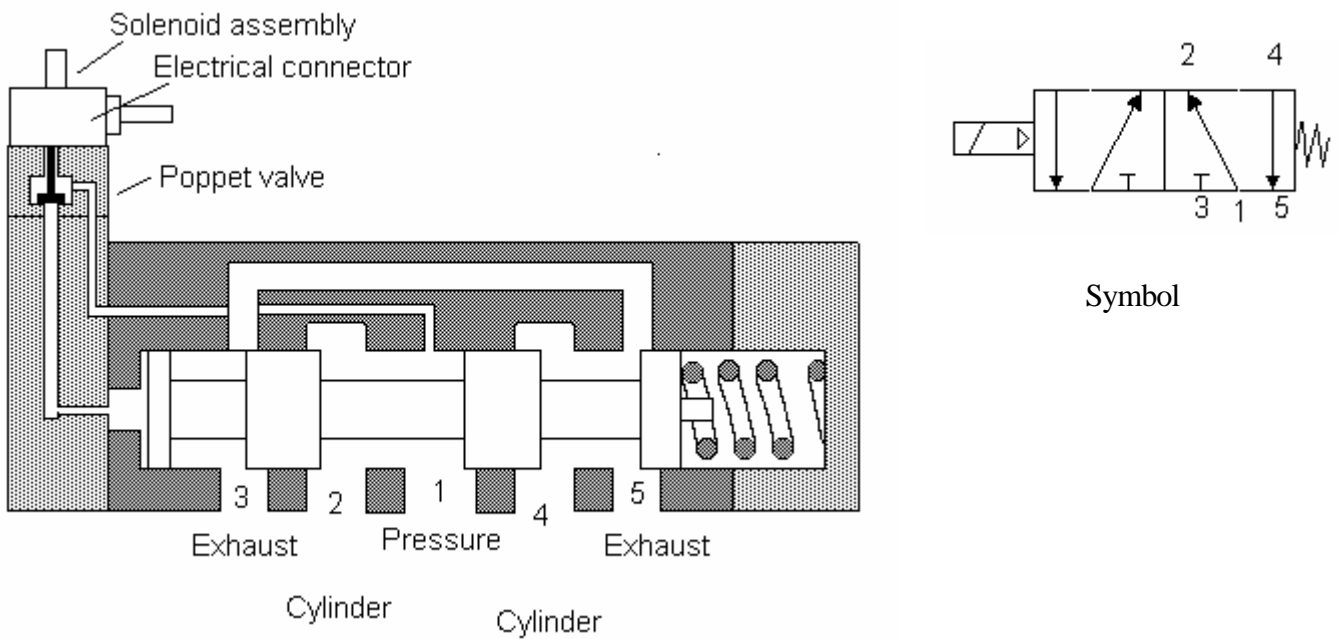

Figure 20

If it is required for the valve to stay switched when the solenoid is deactivated, then another solenoid is needed at the other end to switch it back as shown.

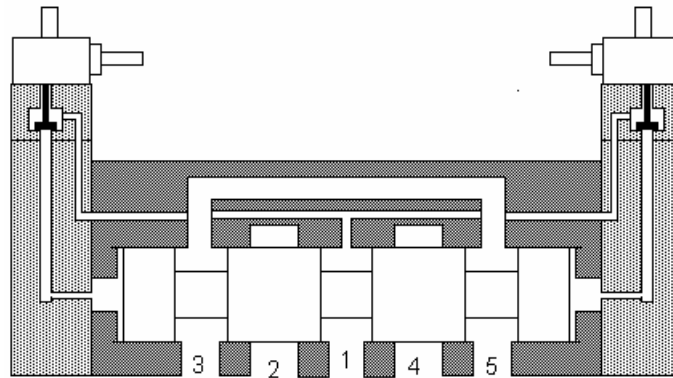

Figure 21

Note that in pneumatics the pressure port is numbered (1) and the servo ports are numbered (2) and (4). The exhaust ports are numbered (3) and (5). It is normal to have five ports in pneumatics because the air is just vented to atmosphere from (3) and (5).

The standard electrical connectors come in four sizes, standard, large, mini and micro. Different manufacturers use different names and numbers. Typical standards are IP65 and DIN40050.

The plug is on the valve and contains three pins. The wider is the earth connection. Pins 1 and 2 are the other connections and pin 3 is not normally used.

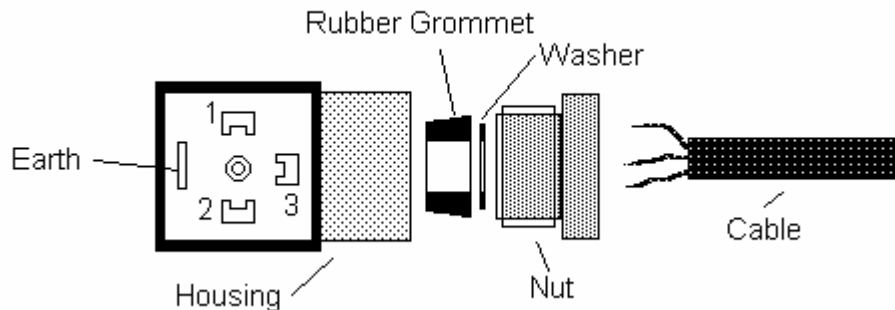

Figure 22

The cable is inserted through the nut, washer and grommet. After the electrical connectors are done up, the nut is tightened squeezing the grommet to the cable making the cable fast and preventing dirt, oil or water getting in.

The inner part with the connectors may be fitted in any direction so that cable comes off the valve in any of four directions. The fixing screw attaches the whole assembly to valve plug.

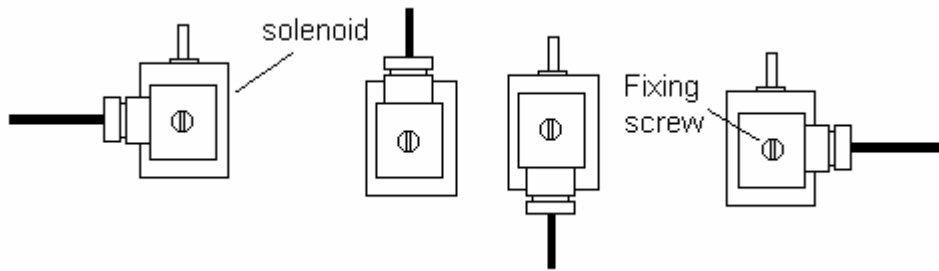

Figure 23

Some of the sockets have lights on them to show when they are switched on. This is useful when tracing faults. The material used depends upon the voltage and the environment in which it is to be used. Typical operating volts are 240 V a.c, 110 V a.c. , 24 V d.c. and 12 V d.c.

Always ensure the socket has the voltage and current rating required.

### OVERRIDES

Mechanical overrides enable the valve to be operated with electrical switching. This is useful in fault tracing as it makes it possible to tell straight away whether the fault is electrical or mechanical.

On direct operating solenoids this may take the form of pushing the plunger with a screw driver. On solenoid poppet valves, a small lever on the base enables the pilot poppet to be opened so allowing air through to pilot operate the valve.

**extra symbol for  
override**

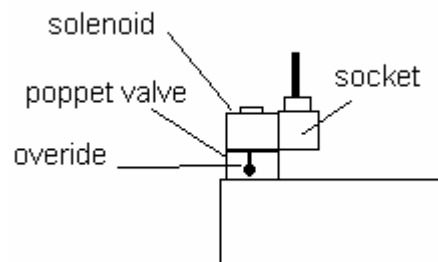
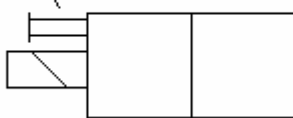

Figure 24

**SELF ASSESSMENT EXERCISE No.1**

1. The diagrams show the design of a typical 5 port 3 position spool valve. The ports in the centre position may be connected or blocked in various ways. The symbols for the first two are drawn to help you understand the method of constructing it. All the valves shown have 3 positions so the symbol has 3 boxes. In all cases the left box must show what the internal connections will be when the piston slides to the right. When this happens,

*P will connect to port \_\_\_\_\_ and T will connect to port \_\_\_\_\_*

Complete the symbols for the other three.

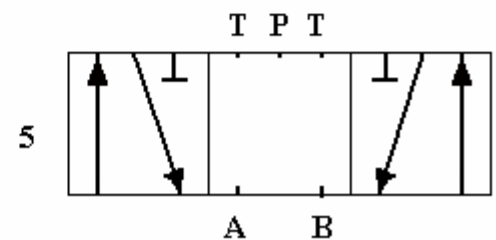
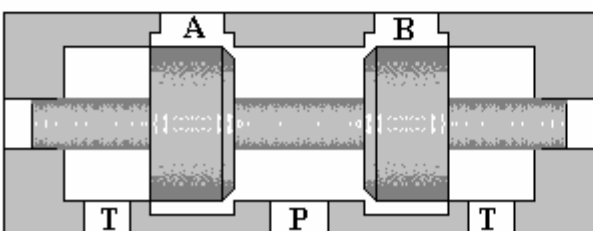
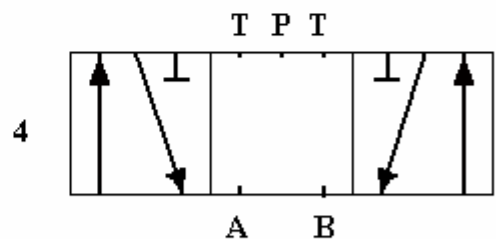
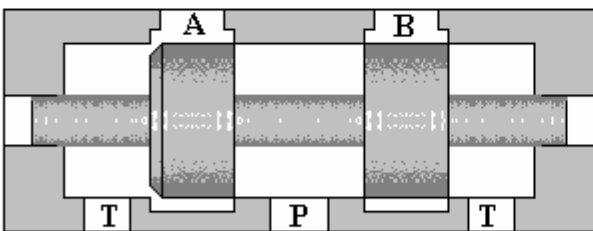
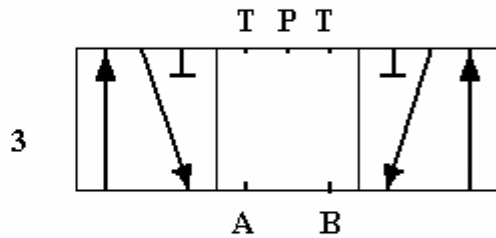
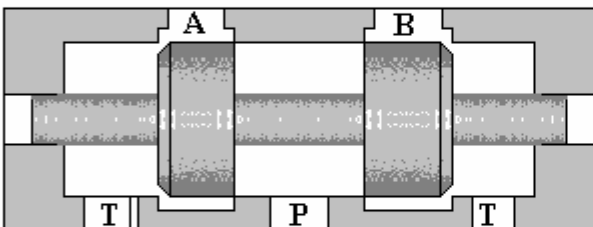
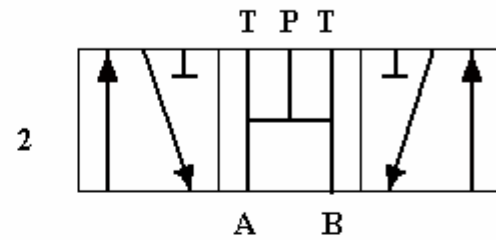
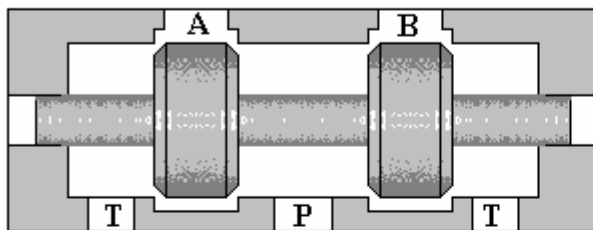
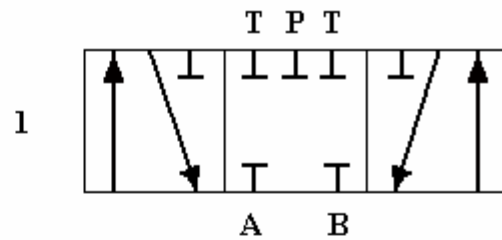
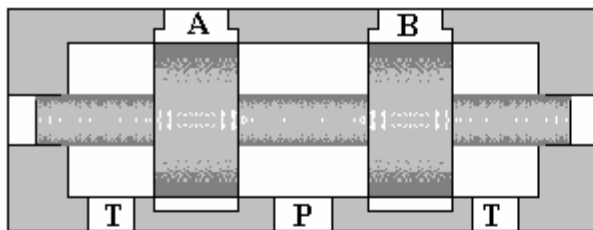

- Bearing in mind that an open centre valve is one in which the pressure port is connected to the tank port in the centre position, identify which of the valves has an 'OPEN CENTRE'.
- For pneumatic valves, the two tank ports are left separated as shown. For hydraulic valves the two 'T' ports are joined together to make one connection, either inside the valve, or in the base, to make it a four port valve. What is the reason for this?
- Most modern valve designs simply have holes on the bottom for the ports. The valves are connected to a base with matching holes. The base has threaded ports, which connect to the valve, and these may be on the top or the sides. The size and position of the holes must conform to ISO or CETOP standards.

*What is the advantage of having bases instead of connecting the pipe work directly to the valves?*

- State and explain one reason why ports A and B might be blocked in the centre position.
- Explain the advantage of an open centre valve.
- Explain why a closed centre valve is essential if it is one in a bank of valves supplied by the same pressure source.

### ANSWERS

1.

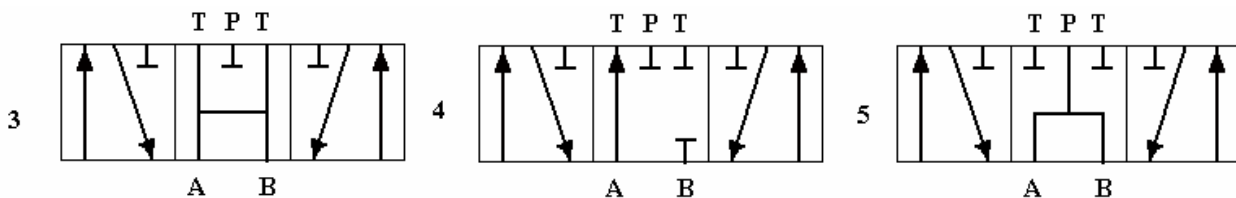

- The pressure port on valves 1, 3 and 4 do not connect to any other and is hence blocked so they have closed centres.
- The tank ports on pneumatic valves are more commonly called exhaust valves and simply vent the air to the atmosphere. On hydraulic systems, the tank ports must be connected to the tank or reservoir with a pipe so having a single port saves having to join two pipes together.
- The valves may be removed for maintenance or replacement without disturbing the connecting pipes.
- If A and B supply an actuator (which is normal), blocking them in the middle position will lock the actuator in place and prevent the mechanism moving inadvertently.
- If the valve is left in the centre position for a long period of time, the pump may circulate freely to tank and the wear and tear on it is reduced but this is only suitable for a single valve system in which the pressure is not required when in this position.
- The centre must be closed; otherwise the pressure will be lost to the tank port and will not be available to the other valves.