

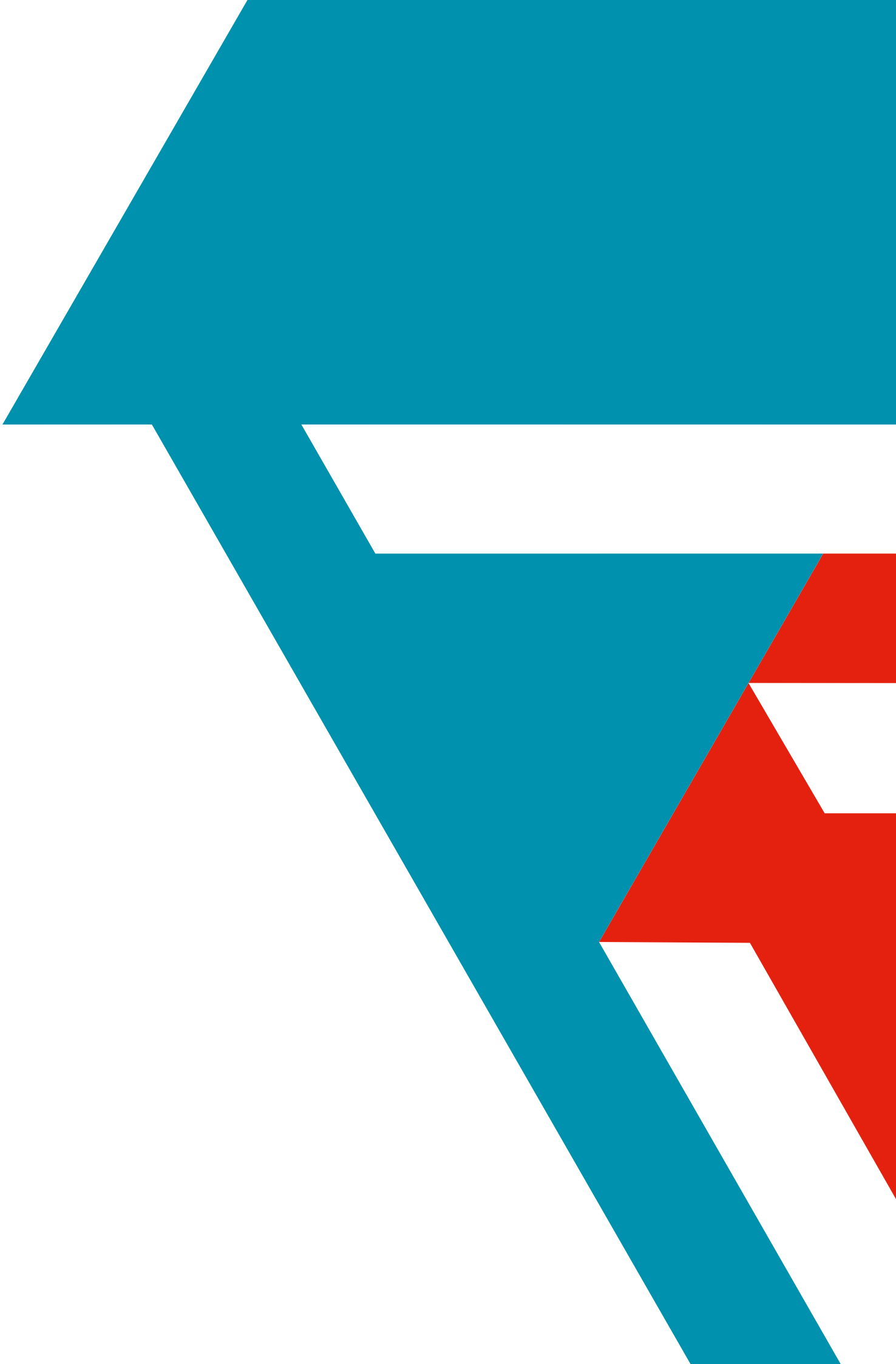

SYSTEM CIRCUIT INTEGRITY IN THE EVENT OF FIRE

Safety cables and systems from the professionals



CONTENTS

	page		page
About us	2	Product features: Legend of pictographs	16
Safety cable systems	6	The most important test procedures and their functions	17
Product overviews	10	ROHS – WEEE – REACH	19
HALOGEN-FREE SAFETY CABLES			
Safety cables product overview	from page 20	with circuit integrity with reference to SEV	
		Safety cables FE180	from page 38
with reference to VDE		with circuit integrity with reference to BS	
NHXMH, (N)HXM(St)H	from page 22	Fire alarm cables Standard/Enhanced	from page 48
N2XH, N2XCH	from page 26	with circuit integrity and system circuit integrity with reference to VDE	
J-H(St)H	32	(N)HXH, (N)HXCH FE180 E30-E60	from page 56
J-H(St)H Fire alarm cables	34	(N)HXH, (N)HXCH E90	from page 66
with reference to SEV		JE-H(St)H / HRH FE 180 E30L / E30-E90	from page 72
FE5-CL	36	Fire alarm cables FE180 E30-E90	from page 76
		Fibre optic safety cables	from page 82
SUPPORT SYSTEMS / CABLE DUCTS			
WUM support measure	86		
Wire mesh cable trays / accessories	from page 87		
Cable trays / accessories	from page 89		
FIXING DEVICES			
Single clamps, type SAS, SAS V4A	91	Multi cable support E30-E90	94
Strap clamps, type B, without trough	92		
Strap clamps, type B, with trough	93		
DISTRIBUTION BOXES			
Cable joints E30/E90	95	Distribution boxes E30	98
Distribution boxes	96	Emergency lighting	99
Connection/terminal boxes	97		
ACCESSORIES			
E0 multi-cable supports	100	Armoured conduits	from page 105
Multi-cable support, Hermann clamp type F	101		
Fire protection plugs / accessories	from page 102		
Fire protection screws	104		
GENERAL INFORMATION			
Colour codes in accordance			
with VDE, CENELEC and SEV standards	111		
E30-E90 support systems	112		
Compendium of standards	from page 113		

DELIVERING EXCELLENCE – EVERY TIME, EVERYWHERE

The “lifeblood” of a modern public or commercial building is the functionality and reliability of the system solutions for communications, building automation, power supply, safety and elevator. This is true of any such construction, irrespective of whether it is an office block, hotel, sports stadium, television studio or a tunnel. Choose a reliable system partner right from the start: choose Datwyler!



Hotels, resorts, hospitals

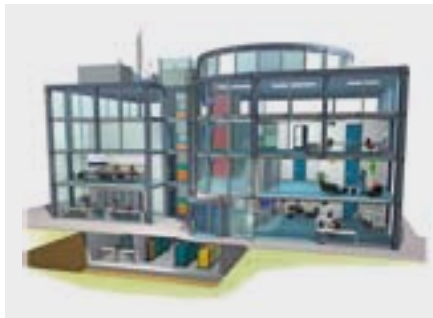

Office blocks

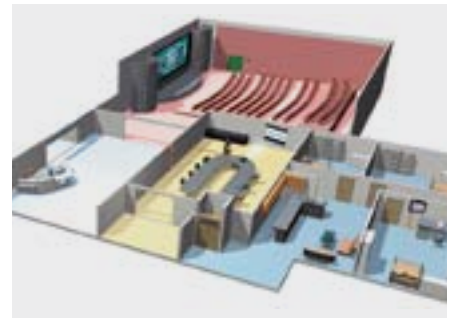

Government buildings, universities



Shopping centres

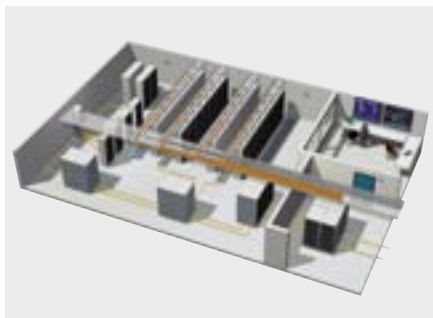

Data centres

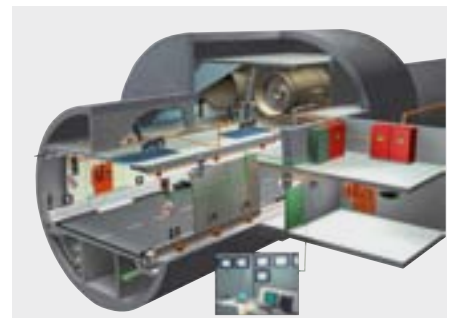

Tunnels

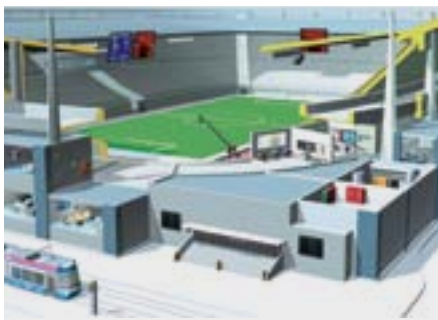

Event arenas, airports



FTTx projects

Datwyler Cabling Solutions is a leading provider of high-quality system solutions and services for electrical and ICT infrastructures in public and commercial buildings and data centres as well as for FTTx networks.

The well-established company, which will shortly celebrate its centenary, leads the way in innovations for applications such as ICT networks, fire safety, energy distribution, building automation and elevators.

Datwyler is a one-stop source of customised solutions for all your specific applications – with all the necessary test certificates, authorisations and approvals and with long-term warranties.

Datwyler successfully operates in the market as a reliable supplier of innovative products and system solutions and – in close cooperation with competent partners – as a complete solutions provider too, covering the whole supply chain: from preliminary studies, through project planning and implementation, to documentation and support of the infrastructures provided.

TURNKEY INSTALLATIONS

Datwyler Cabling Solutions does not only supply integrated system solutions, but has positioned itself successfully as a complete solutions partner: for all manner of purpose-built constructions including multi-site projects, for data centres and for FTTx projects. Our successful processing of projects derives from our high-level skills in developing and manufacturing the required products and systems, our comprehensive applications expertise, our international presence and our globally established partner network.

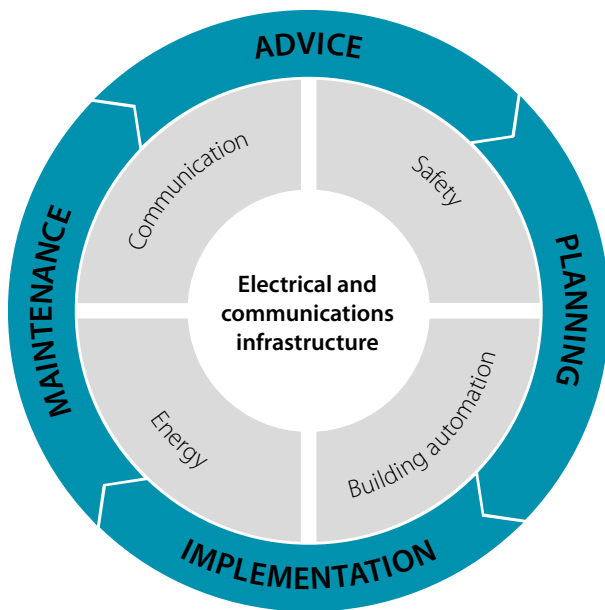

Our international presence and our worldwide, actively managed and certificated partner network have also proved invaluable in the multi-site projects of major clients. National and international companies rely on Datwyler on-the-spot site audits. Using the site surveys as a base, our engineering experts work out customised solutions with uniform standards for all the sites concerned. Our complete solutions package is rounded off by the implementation and assurance of regular operations. While operations are running, we provide servicing and maintenance work to optimise your infrastructure solution. These MAC (move, add, change) services increase the performance and working life of your equipment.

High-quality solutions for all your applications

Year on year, Datwyler invests in even better materials and process technologies, production resources and test methods. This is why our system solutions always keep ahead of the current norms and repeatedly set new standards. The important functions which our solutions must deliver in practice demand the highest possible level of safety and reliability. This is why we measure each product against strin-

gent quality standards before it leaves the company. Of course, all our processes are ISO 9001:2008 / ISO 14001:2004 certified.

Our sustainable solutions provide you with high-level operational reliability coupled with low operating costs. The proof that Datwyler systems can deliver these benefits has been evident for many years in thousands of installations around the world. In addition, we have a particularly keen eye for consistent, intelligent solutions that simplify planning, sourcing and installation and shorten your construction times.

We have the solutions for all your applications, whatever they are – high-speed communications networks, modern energy distribution, monitoring and control services, fire alarm systems or lift cabling.

Or you may want to integrate new systems, interconnect and automate existing systems or simply ensure a reliable power supply. All this is possible with our carefully thought out, pre-assembled and prefabricated subsystems.

Just tell us how, when and where

Besides quality and product price, the logistics performance capability of suppliers is a decisive factor in the successful handling of construction projects. This is particularly true of major projects. With its years of experience and high logistics competences, Datwyler can handle even time-critical major projects smoothly and to the complete satisfaction of customers. Just-in-time deliveries at the right place are all in a day's work for us and our partners.



Besides delivering straight to the construction site, we also offer additional logistics services (time slots, pre-fitted and pre-assembled products etc.). Many customers and suppliers have a direct link to our IT system for rapid and flexible order processing.

As regards cable pre-assembly, Datwyler also has wide-ranging expertise, the product of decades of experience. In our modern cable cutting centre, the engineering department passes the cutting orders electronically without any media discontinuity straight to the production area. Our efficient order communication system with all our customers is due to years of experience with B2B interfaces.

In many countries Datwyler works in close co-operation with certified distribution partners. Thus, our customers can rely on the consistently high quality standard of all Datwyler products and solutions whilst benefiting from local contacts and logistics services.

We support you in realising your infrastructure project – reliably, capably, complete and with the highest quality!

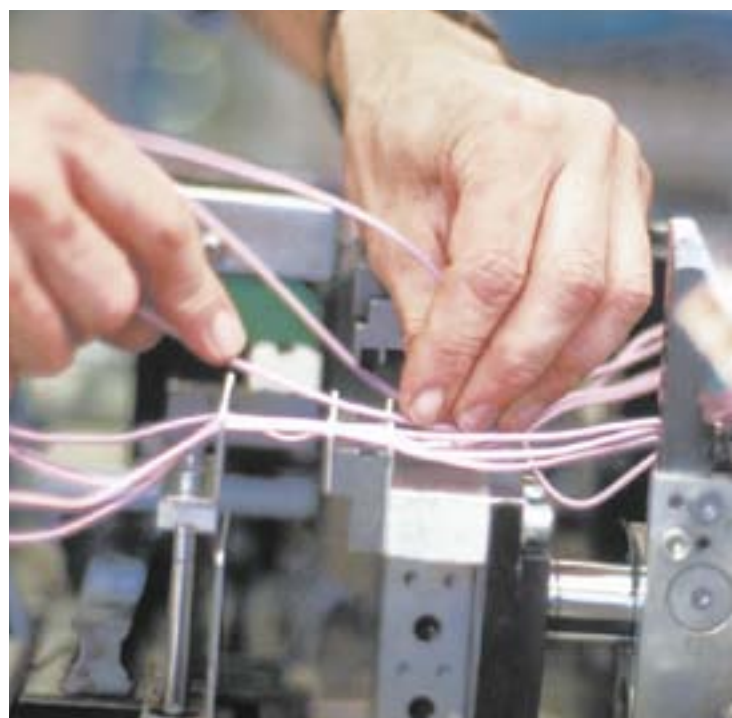

CONNECTIONS THAT WORK
in case of fire

SAFETY CABLE SYSTEMS





Whether in football stadiums, airports or metro stations – wherever masses of people assemble in a confined space, the risk of catastrophe in case of fire is especially great. That's why special cabling systems are particularly important – systems that continue to function dependably even during a fire providing life-saving security for an extended time. As a leading provider of safety cable systems, Datwyler Cabling Solutions closely collaborates with fire-protection specialists to develop innovative solutions. These systems provide continuous power and data transmission even in a fire, and thus form the backbone of an effective fire safety concept.



Mobility is increasing rapidly worldwide – and with it the sizes of crowds in airports and train stations. Other confined spaces in which thousands of people congregate daily include office towers, shopping centres, event arenas and entertainment parks.

Safety standards meet cable technology

Fire safety regulations are being continually tightened to minimise fire damage and provide the best possible protection of life and property. Datwyler is a step ahead in the race, offering innovative total solutions that incorporate electrical cable systems with enhanced circuit integrity. These systems go beyond the toughest European norms. System Circuit Integrity testing covers not just individual cables with intrinsic fire resistance properties but complete cable systems including the associated supports and fasteners. In contrast to conventional circuit integrity testing, this method of comprehensive testing reflects the actual performance of entire cable systems installed in a buildings that catches on fire.

Patented ceramic technology

Datwyler has been producing safety cables using patented "Keram" technology for many years. The materials and processing of the ceramic-insulated products are being constantly improved. The latest generation of cables offers a variety of tested, standard-compliant installation options that outperform by far the conventional installation methods (in accordance with DIN 4102-12).

ADDED VALUE
for your fire safety installation

SAFETY CABLE SYSTEMS



Leading know-how

As a provider of complete solutions for safety cables systems, Datwyler Cabling Solutions possesses comprehensive know-how accumulated over decades:

- Co-development of enhanced circuit integrity (System Circuit Integrity) tests in collaboration with renowned testing institutes in the early 1990s.
- Sound knowledge of safety engineering and building codes and standards.
- Leading material, production and process know-how in the fabrication of safety cables incorporating patented and proven "Keram" (ceramic) technology.
- Development of the first metal-free fibre-optic cable with intrinsic fire resistance and E30 enhanced circuit integrity through combining existing technical competence in data and safety cable engineering.
- Comprehensive systems competence.
- Collaboration with renowned technical universities, international standardization committees and independent testing institutes.

Diverse applications

Datwyler safety cable systems with enhanced circuit integrity (System Circuit Integrity) are used wherever stringent fire-safety requirements must be met and people and property could be at risk due to fire and smoke:

- Airports, train stations, metro stations
- Hotels, resorts and hospitals
- Sports stadiums, theatres and concert halls
- Office and exhibition buildings, public buildings
- Tunnels for road and rail

System solutions

- The Datwyler safety cable line includes halogen-free, low-smoke emission and flame retardant cables with circuit integrity and intrinsic fire resistance.
- The safety system product line includes support systems, mounting components and appropriate accessories to ensure enhanced circuit integrity (System Circuit Integrity).
- Our FO Universal Safety cables are the first metal-free fibre-optic cables with E30 enhanced circuit integrity with reference to DIN 4102-12.
- Fire protection seminars and special calculation programmes offer engineers and installers valuable support.
- Datwyler offers comprehensive services up to and including complete solutions and multi-site projects.



Shopping mall "Galeria Krakowska" in Krakow, Poland

Selected reference projects

Allianz Arena	Munich	Trade Fair	Stuttgart
Dexia BIL	Luxembourg	Reichstag	Berlin
International Airport	Frankfurt	Subway	Munich
World Trade Center	Dubai	Metro	Prague
Galeria Krakowska	Krakow	Gotthard motorway tunnel	Gotthard
New main station (Lehrter Bahnhof)	Berlin	Mercedes Benz Museum	Stuttgart
Crystal Plaza Towers	Sharjah City	Juan Carlos I. Tunnel	Vielha

Customer value in focus

Datwyler stands for more than the production and distribution of products. For your safety cabling systems we provide everything from one source: modular system solutions with high-quality cables and components, with all the necessary test certificates, approvals and authorizations. You can rely on our expert support for all aspects of our supply – beginning with planning, consultancy, through logistics, installation and ending with system maintenance. The interaction of these elements creates added value: As a customer you benefit from cost-effective installation thanks to our innovative installation methods, acceptance without any difficulties, low insurance rates, and dependable transmission of power and data even in case of fire.



Crystal Plaza Towers in Sharjah, United Arab Emirates

SAFETY CONCEPTS FOR BUILDINGS

Proven quality

Datwyler Cabling Solutions is the first European manufacturer to develop a complete system solution that meets the demands of today's industry for reliable power supply and data transmission in the event of fire. Datwyler cables and our approved cabling system components are the result of many years of intensive development in coordination with the relevant standardisation bodies.

Selected raw materials and special compounds in combination with unique installation methods are what give a Datwyler system its high quality and maximum guaranty of safety in the event of fire.

Datwyler cables and safety system components are used wherever people, machinery and equipment are endangered by fire and smoke emission: in buildings with high density of occupants as well as in facilities containing large concentrations of valuable property.

Our safety cable systems have to be highly reliable when it comes to practical operations. This is why Datwyler measures each and every product against strict quality standards before it leaves the company. Specifically, this means that all processes are integrated into the comprehensive management system in accordance with ISO 9001 and ISO 14001. Beyond this, additional application-specific inspection and test methods ensure that Datwyler cables and safety cable systems exceed the requirements of our customers as well as the stringent standards specified by the various countries in which our products are used.

Steel conduits and halogen-free plastic conduits
from page 105



Gas concrete plugs
F90
from page 104



Fire protection plugs F90
installation depth 30 mm
from page 102



Screws F90
from page 104



Single clamps
type SAS
page 91

Strap clamps
type B, without trough
page 92



Strap clamps
type B, with trough
page 93

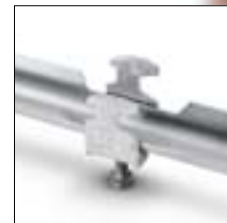

Identification signs
page 104



Safety cables
E90 Keram
from page 66



WUM
Support measure
from page 86

Modular shaft lighting system

Safety cables
E90 Keram
from page 66



Safety cables
E30-E60 Keram
from page 56

Flat form cables
with integrated data bus



Cable joints
E30/E90 for all
dimensions
page 95

Elevator travelling cables



Fibre optic safety cable
E30 with reference to
DIN 4102-12, 30 minutes
page 82



Distribution box
E30-E90
type "Hercules"
page 96



Cable trays
E30/E90
spacing \leq 1500 mm
page 87



Connection/terminal box
E30-E90
page 97



Multi cable support
"Hermanschelle" E30/E90
spacing \leq 600/800 mm
page 94

SAFETY CONCEPTS FOR TUNNELS

Steel conduits
and halogen-free
plastic conduits
from page 105

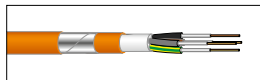

Safety cables
E30-E60 Keram
from page 56



Identification signs
page 104

Fire protection plugs F90
installation depth 30 mm
from page 102

Single clamps
type SAS V4A
page 91



Gas concrete plugs F90
from page 104



Screws F90
from page 104



Distribution boxes
E30/E90
from page 98



Cable trays
E30/E90
page 87



Multi cable support
"Hermanschelle" E30/E90
page 94



Flat form cable with
integrated data bus

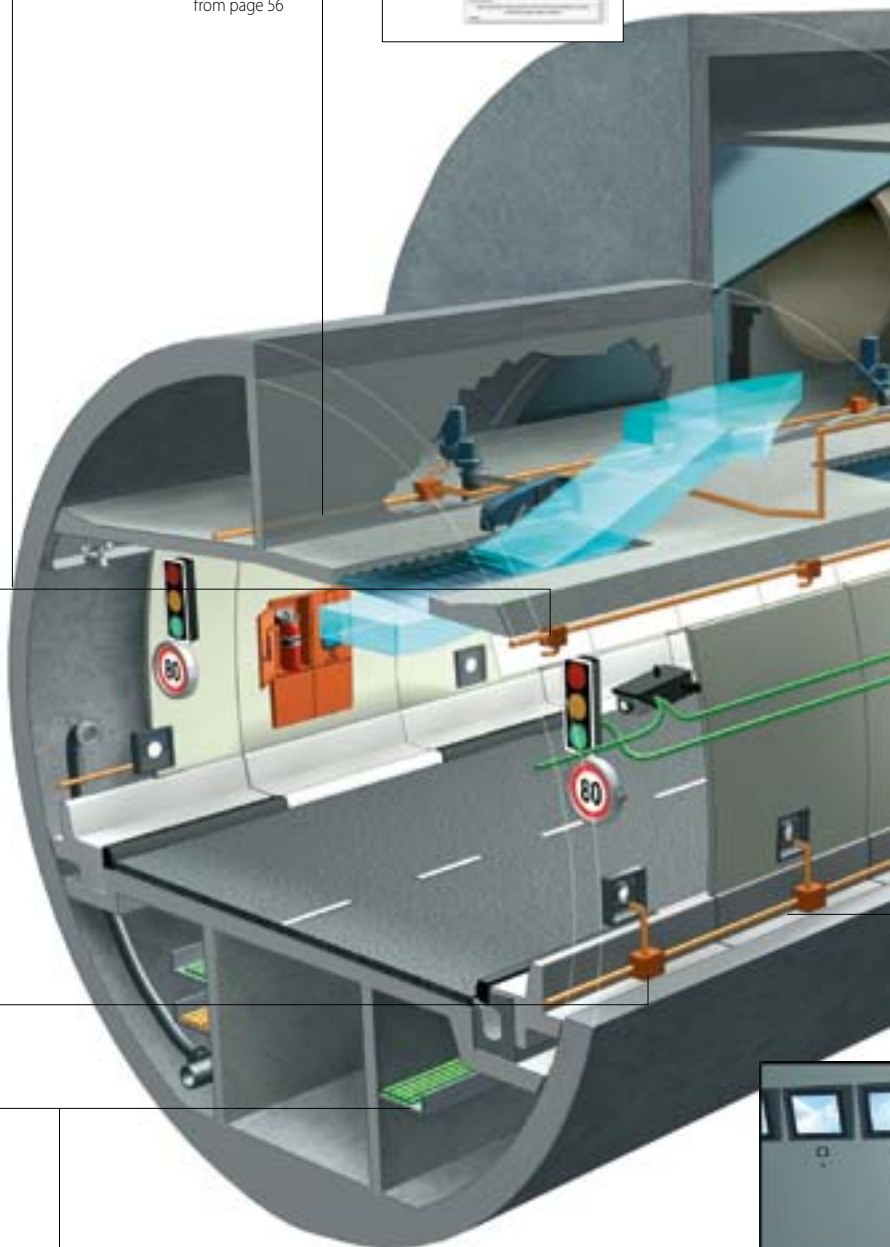

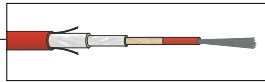
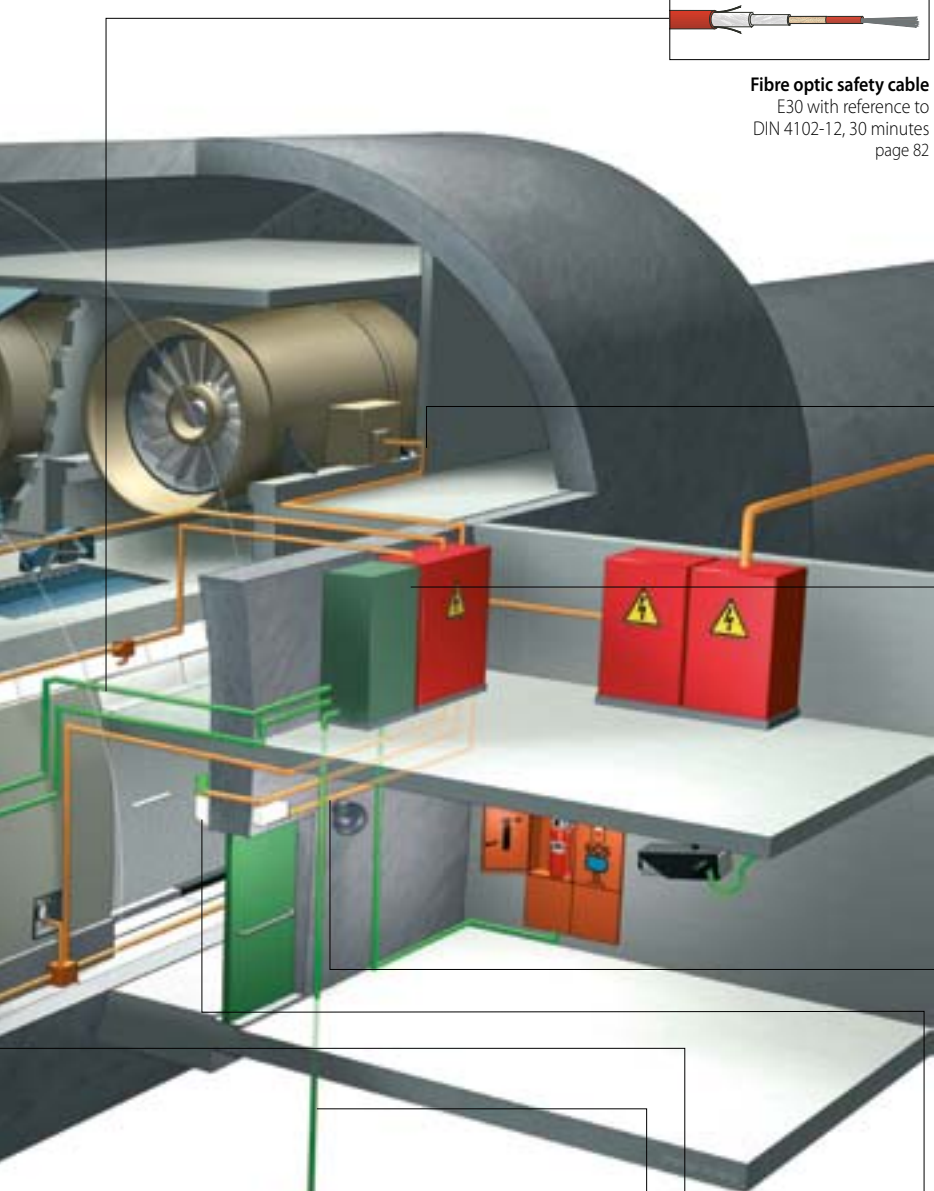

Fibre optic safety cable
E30 with reference to
DIN 4102-12, 30 minutes
page 82

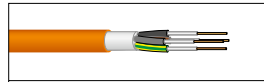

Safety cables
E30/E90 Keram
from page 56

Cable joints E30/E90
for all dimensions
page 95



Distribution box
E30-E90
type "Hercules"
page 96



Strap clamps
type B, without trough
page 92



Strap clamps
type B, with trough
page 93







Emergency lighting
for escape routes
page 99



Safety cables
E30-E90 Keram
from page 56

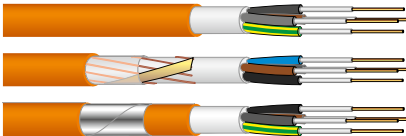
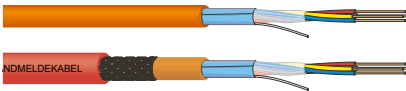

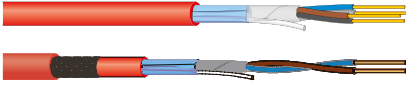
Fibre optic safety cable
E30 with reference to
DIN 4102-12, 30 minutes
page 82

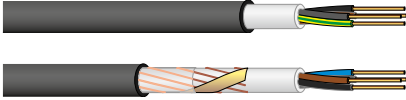
CABLE TECHNOLOGY FOR HIGHEST SAFETY REQUIREMENTS

CABLES	APPLICATIONS	PRODUCT RANGE/STANDARDS
Safety cables with intrinsic fire resistance		
<p>Low voltage cables up to 0.6/1 kV E30-E90; FE180; BS 6387 CWZ; PH30-120, Rf-1 1½</p>  <p>with mechanical protection</p>	<p>Safety cables with circuit integrity, intrinsic fire resistance and enhanced circuit integrity to maintain power supplies to sprinkler systems, emergency lighting, smoke and heat extraction systems, emergency lift supplies and fire fighting lifts.</p>	<p>Single core cables from 1.5 to 630 mm², Multi-core cables from 1.5 to 300 mm², also available with mechanical protection</p> <p>Standards/Approvals IEC, EN, CENELEC, BS, DIN VDE, SEV, NBN, VKF/AEAI, VdS, GOST-R, Ukraine</p>
<p>Wiring and fire alarm cables up to 225 V E30-E90; FE180; BS 6387 CWZ; PH30-120, Rf-1 1½</p>  <p>with mechanical protection</p>	<p>Safety cables with circuit integrity, intrinsic fire resistance and enhanced circuit integrity to maintain power supplies and data transmission to fire alarm systems, public address and voice alarm systems.</p>	<p>Single pair or multi-pair cables, individually or collectively screened, also available as fire alarm cable and with mechanical protection.</p> <p>Standards/Approvals IEC, EN, CENELEC, DIN VDE, SEV, NBN, GOST-R</p>
<p>Fibre-optic cables with reference to DIN 4102-12, 30 minutes (E30); IEC 60331-25</p>  <p>with rodent protection</p>	<p>FO Universal Safety cables for indoor and outdoor applications.</p>	<p>Loose tube construction with up to 60 single-mode or multimode fibres, with non-metallic rodent protection.</p> <p>Standards/Approvals IEC, EN, CENELEC, DIN VDE</p>
Safety cables with circuit integrity		
<p>Fire alarm cables 300/500 V BS 6387 CWZ; FE180; BS 8434-2, EN 50200 (PH 30-120) and Annex E</p>  <p>with mechanical protection</p>	<p>Safety cables with circuit integrity to maintain power supplies and data transmission to fire alarm systems, emergency lighting, public address and voice alarm systems.</p>	<p>Screened multi-core cables from 1.0 to 4 mm², also available with mechanical protection.</p> <p>Standards/Approvals BS, EN, CENELEC, GOST-R, BASEC, LPCB, VKF/AEAI</p>
Safety cables with improved characteristics in case of fire		
<p>Low voltage cables up to 0.6/1 kV</p> 	<p>Safety cables with improved characteristics in case of fire – an alternative to traditional PVC cables, where no circuit integrity is required.</p>	<p>Single core cables from 1.5 to 630 mm², multi-core cables from 1.5 to 300 mm², also available with mechanical protection and as flexible, oil resistant version.</p> <p>Standards/Approvals IEC, EN, CENELEC, DIN VDE, SEV, GOST-R</p>

Are you looking for a building, technology and infrastructure management software which enables effective planning, management, documentation and control of all objects and processes around your fire safety infrastructure? Feel free to ask for details about "Panorama"!

SYSTEM COMPATIBLE INSTALLATION COMPONENTS

SYSTEM COMPONENTS	APPLICATION
<p data-bbox="193 427 568 456">Single clamps, multi cable supports</p> 	<p data-bbox="804 483 1321 539">Single clamps to install single cables or cable bundles conforming to common practice.</p> <p data-bbox="804 568 1326 624">Multiple cable supports for a cost effective installation of several cables.</p> <p data-bbox="804 654 1267 710">These components facilitate the quick and easy retrospective/subsequent installation of cables.</p>
<p data-bbox="193 813 373 842">Support systems</p> 	<p data-bbox="804 871 1262 927">Special support systems to install several cables conforming to common practice.</p> <p data-bbox="804 956 1342 1012">Approved for ceiling and wall mounting with possibility of easy retrospective/subsequent installation of cables.</p> <p data-bbox="804 1041 1342 1128">Corresponding fixing devices, such as fire safety dowels, installation screws and setting tools are available for all support systems.</p>
<p data-bbox="193 1232 443 1261">Connecting technology</p> 	<p data-bbox="804 1288 1414 1344">Cable joints to connect Datwyler safety cables with intrinsic fire resistance and enhanced circuit integrity.</p> <p data-bbox="804 1373 1406 1460">Distribution boxes with intrinsic fire resistance and circuit integrity E30-E90, also available as fire resistant covers to protect standard connections or junction blocks.</p> <p data-bbox="804 1489 1394 1545">Distribution boxes with intrinsic fire resistance and enhanced circuit integrity for high-voltage and low-voltage cables.</p>
<p data-bbox="193 1624 296 1653">Seminars</p>  <p data-bbox="448 1935 644 1993">For further information please visit www.cabling.datwyler.com</p>	<p data-bbox="804 1682 1166 1711">Datwyler is setting new standards.</p> <p data-bbox="804 1740 1362 1796">Our safety cables combined with our system components make up the perfect and cost effective safety solution.</p> <p data-bbox="804 1825 1331 1912">Datwyler regularly holds seminars on cabling systems with circuit integrity and enhanced circuit integrity (System Circuit Integrity) as well as on firestop systems.</p>

www.cabling.datwyler.com

PRODUCT FEATURES

The following pictograms show the essential features of our products and give an easy reference.

They are allocated to the articles on the data sheets and provide you with a quick overview



Zero halogen, non corrosive gases

These Datwyler cables are halogen-free and reduce possible damage to health or material to a minimum.

IEC 60754-1 and IEC 60754-2, EN 50267-2-1, EN 50267-2-2, EN 50267-2-3 VDE 0482-267 part 2-1, 2-2 and 2-3



Flame propagation

These Datwyler cables use a high-performance, flame retardant material that is self-extinguishing.

IEC 60332-1-2, EN 60332-1-2, VDE 0482-332-1-2



Flame spread

These Datwyler cables are flame resistant and prevent the propagation of a fire from one location to another

IEC 60332-3-22 to 25 cat. A-D, EN 60332-3-22 bis 25 cat. A-D, VDE 0482-332-3-22 to 25 cat. A-D



Smoke density

These Datwyler cables emit minimum smoke in the event of fire. Exit routes and fire brigade access are not restricted.

IEC 61034-1 and IEC 61034-2, EN 61034-1 and EN 61034-2, VDE 0482-1034 part 1 and 2



Circuit integrity (FE/PH)

These Datwyler cables with circuit integrity guarantee the function of a single cable for a defined duration. (FE = flame time and influence time)

IEC 60331-1, IEC 60331-2 and part 21,23, 25, EN 50200 with Annex E, EN 50362, VDE 0472 part 814, VDE 0482-200, VDE 0482-362, BS 8434-2, BS 6387 (cat. C/W/Z)



System Circuit integrity (E30-E90)

These Datwyler cables together with certified Datwyler fixing systems guarantee enhanced circuit integrity of the complete electrical cable installation for a defined time. (E30=30 minutes, E60=60 minutes, E90=90 minutes)

DIN 4102 part 12 (E30-E90) NBN 713.020 (Rf1, Rf1½)

THE MOST IMPORTANT TEST PROCEDURES AND THEIR FUNCTIONS



Test on gases evolved during combustion

This test procedure provides information if the insulation material of the cable sheath creates corrosive gases in the event of fire.

Halogen parts or other material in small quantities can be easily identified with this test due to the strong change of pH and conductivity. The conductivity is $< 10\text{mS/mm}$

Standards

- IEC 60754-1 and IEC 60754-2
- EN 50267-2-1, EN 50267-2-2
- EN 50267-2-3
- VDE 0482-267 part 2-1, 2-2 and 2-3

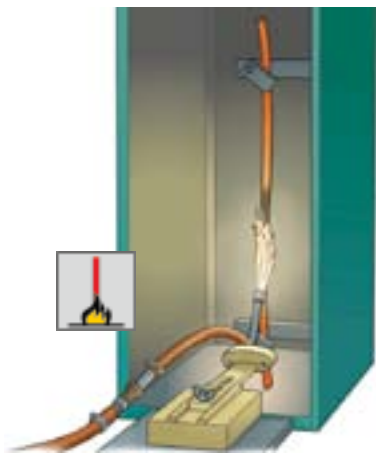

Test for vertical flame propagation (single insulated wire or cable)

This test method tests a cable sample (length: 60 cm) for burning behaviour.

The flame must extinguish itself, and the burn damage must not reach the upper end of the cable sample.

Standards

- IEC 60332-1-2
- EN 60332-1-2
- VDE 0482-332-1-2

Test for vertical flame spread (bunched wires or cables)

This test method tests a cable bundle (length: 360 cm) with regard to fire propagation.

The flames must extinguish themselves, and burn damage must not exceed a defined height.

Standards

- IEC 60332-3-22 up to 25 Cat. A-D
- EN 60332-3-22 up to 25 Cat. A-D
- VDE 0482-332-3-22 up to 25 Cat. A-D

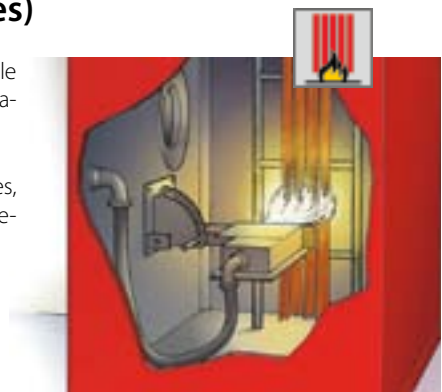

Measurement of smoke density

This test checks smoke development when burning the cable or the impairment of the visibility by burning cables.

The reduction in light transparency is measured in a standard chamber.

Standards

- IEC 61034-1 and IEC 61034-2
- EN 61034-1 and EN 61034-2
- VDE 0482-1034 part 1 and 2

THE MOST IMPORTANT TEST PROCEDURES AND THEIR FUNCTIONS

Test of circuit integrity (FE/PH)

This test establishes whether a single cable can maintain circuit integrity during and after exposure to a fire for a time period of at least 180 minutes. Cables which fulfil the requirements of this test are marked with "FE180" after their type designation.

There is no obligation to test the cable for functional integrity beyond the designated period.

Remark:

This test is not equivalent to the test for extended functional integrity (System Circuit Integrity) in accordance with DIN 4102-12

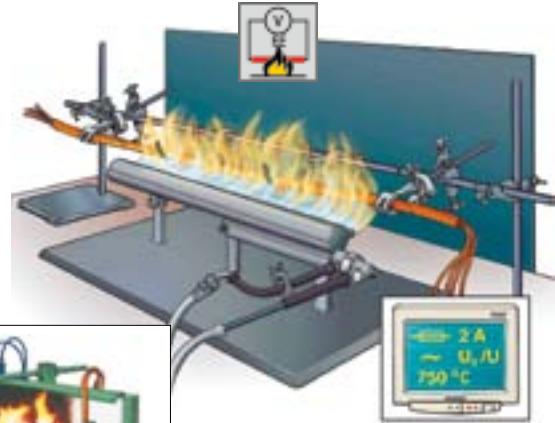

Test of circuit integrity (fire only)

- IEC 60331-11/-21/-23/-25 (>750°C)
- BS 6387 (cat. C) (950°C)
- VDE 0472-814 (>750°C)

Test of circuit integrity (fire and water)

- BS 6387 (cat. W) (650°C, 3A)
- VdS 3423 (>830°C, 3A)
- EN 50200 Annex E (>830°C, 2A)

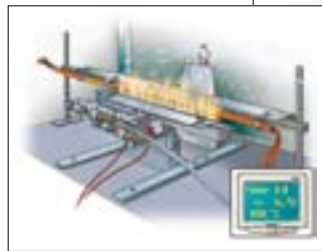

Test of circuit integrity (fire and mechanical shock)

- IEC 60331-1/-2 (>830°C, 2A)
- EN 50200 (PH) (>830°C, 2A)
- EN 50362 (> 830°C, 2A)
- BS 6387 (cat. Z) (950°C, 3A)

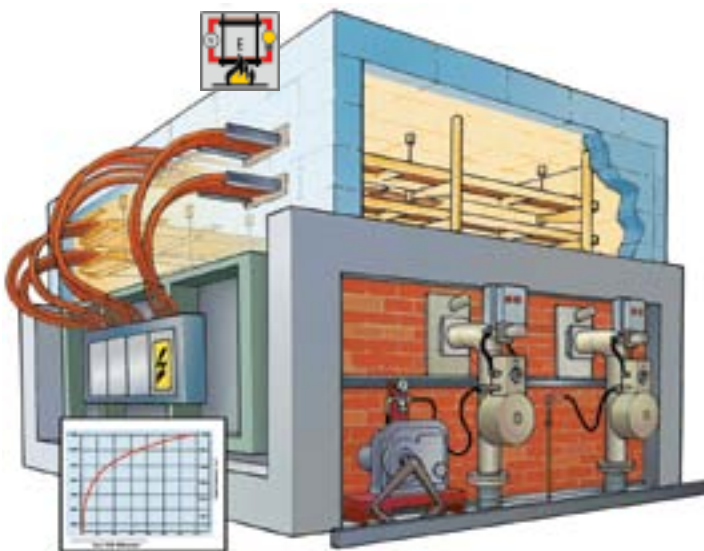

Test of System Circuit Integrity of electrical cable installations

This standard describes the requirements and the actions to achieve enhanced circuit integrity of the complete electrical cable installation in the event of fire.

While the circuit integrity test (FE/PH) is only for single cables, in this test cables are tested together and in connection with practical fixing systems.

It is important to note that there is no connection between the two standards, circuit integrity (FE/PH) and enhanced or System Circuit Integrity (E).

The test is carried out and certified from state recognised institutes.

Standards

- DIN 4102 part 12 (E30-E90)
- NBN 713-020 (Rf1, Rf1 1/2)

Better than the standard!

This test (E30-E90) is now the only worldwide standard for guaranteeing the functional integrity of the complete electrical cable installation, including the fixing components, under normal operating conditions.

ROHS – WEEE – REACH

Statement from Datwyler:

As an environmentally conscious manufacturer and supplier of cabling solutions it is our concern not to use any environmentally harmful substances in our products.

Based on current information, the herein-mentioned guidelines / regulations for banned substances are fully complied with. Exceptions are noted as such on the relevant data sheet.



ROHS

DIRECTIVE 2011/65/EU
OF THE EUROPEAN PARLIAMENT
AND OF THE COUNCIL
of 8 June 2011 on the restriction of
the use of certain hazardous substances
in electrical and electronic equipment
(recast)

WEEE

DIRECTIVE 2012/19/EU
OF THE EUROPEAN PARLIAMENT
AND OF THE COUNCIL
of 4 July 2012 on waste electrical and
electronic equipment (WEEE)
(recast)

REACH

REGULATION (EC) No 1907/2006
OF THE EUROPEAN PARLIAMENT AND OF THE COUNCIL
of 18 December 2006 concerning the Registration,
Evaluation, Authorisation and Restriction of Chemicals
(REACH), establishing a European Chemicals Agency,
amending Directive 1999/45/EC and repealing
Council Regulation (EEC) No 793/93 and Commission
Regulation (EC) No 1488/94 as well as Council Directive
76/769/EEC Commission Directives 91/155/EEC,
93/67/EEC, 93/105/EC and 200/21/EC

and

COMMISSION REGULATION (EU) No 143/2011
of 17 February 2011 amending Annex XIV to Regulation
(EC) No 1907/2006 of the European Parliament and
of the Council on the Registration, Evaluation, Authorisation
and Restriction of Chemicals

SAFETY CABLES PRODUCT OVERVIEW

Cable type	Page	Category	Fire characteristics				Design				Rated voltage				General properties										
			Halogen-free	Flame retardant	Fire resistant	Minimum smoke emission	Circuit integrity	System Circuit: integrity E30	System Circuit: integrity E60	System Circuit: integrity E90	DIN VDE	EN/CLC/IEC	SEV	BS	max. 225 V	max. 300 V	300/500 V	450/750 V	0.6/1 kV	max. 70°C	max. 90°C	Concentric	Overall shield	Armoured	
Halogen-free safety cables																									
NHXMH	22	E0	●	●	●	●				●					●			●							
(N)HXM(St)H	24	E0	●	●	●	●				●					●			●					●		
N2XH	26	E0	●	●	●	●				●								●		●					
N2XCH	30	E0	●	●	●	●				●								●		●	●				
J-H(St)H..Bd, grey	32	E0	●	●	●	●				●					●			●					●		
J-H(St)H..Bd, red	34	E0	●	●	●	●				●					●			●					●		
FE5-CL	36	FE5	●	●	●	●					●							●		●				●	
Halogen-free safety cables with circuit integrity																									
Datwyler Keram FE180	38	FE180	●	●	●	●	●	●				●						●		●					
Datwyler Keram FE180, flexible	42	FE180	●	●	●	●	●					●			●					●					
Datwyler Keram FE180-CL	44	FE180	●	●	●	●	●	●				●						●		●				●	
Standard Fire Safety cable	48	FE180 UK	●	●	●	●	●					●			●					●			●		
Standard Fire Safety cable flex	50	FE180 UK	●	●	●	●	●					●			●					●			●		
Enhanced Fire Safety cable	52	FE180 UK	●	●	●	●	●					●			●					●			●		
Standard Fire Safety cable, armoured	54	FE180 UK	●	●	●	●	●					●			●					●			●	●	

Cable type	Page	Category	Fire characteristics								Design				Rated voltage				General properties							
			Halogen-free	Flame retardant	Fire resistant	Minimum smoke emission	Circuit integrity	System Circuit Integrity E30	System Circuit Integrity E60	System Circuit Integrity E90	DIN VDE	EN/CLC/IEC	SEV	BS	max. 225 V	max. 300 V	300/500 V	450/750 V	0.6/1 kV	max. 70°C	max. 90°C	Concentric	Overall shield	Armoured		
Halogen-free safety cables with circuit integrity and System Circuit Integrity																										
(N)HXH FE180 E30-E60 Datwyler Keramik	56	E30-E60	•	•	•	•	•	•	•	•	•	•														
(N)HXCH FE180 E30-E60 Datwyler Keramik	60	E30-E60	•	•	•	•	•	•	•	•	•	•														
(N)HXH FE180 E30-E60 CL Datwyler Keramik	62	E30-E60	•	•	•	•	•	•	•	•	•	•														•
(N)HXH FE180 E90 Datwyler Keramik	66	E90	•	•	•	•	•	•	•	•	•	•														
(N)HXCH FE180 E90 Datwyler Keramik	70	E90	•	•	•	•	•	•	•	•	•	•														
JE-H(S)tH...Bd FE180 E30 L, orange Datwyler Keramik	72	E30	•	•	•	•	•	•	•	•	•	•				•										•
JE-H(S)tH...Bd FE180 E30-E90, orange Datwyler Keramik	74	E30-E90	•	•	•	•	•	•	•	•	•	•				•										•
JE-H(S)tH...Bd FE180 E30 L, red Datwyler Keramik	76	E30	•	•	•	•	•	•	•	•	•	•				•										•
JE-H(S)tH...Bd FE180 E30-E90, red Datwyler Keramik	78	E30-E90	•	•	•	•	•	•	•	•	•	•				•										•
JE-H(S)tHRH...Bd FE180 E30-E90, red Datwyler Keramik	80	E30-E90	•	•	•	•	•	•	•	•	•	•				•										•
FO Universal ZGGFR Safety / U-DQ(ZN)BH (Fibre-optic safety cable)	82	(E30)	•	•	•	•	•	•	•	•	•	•		•												•
FO Universal wbGGFR Safety / U-DQ(ZN)BH (Fibre-optic safety cable)	84	(E30)	•	•	•	•	•	•	•	•	•	•		•												•

PREVENTIVE FIRE PROTECTION

300/500V NHXMH

Power cable

halogen-free, with improved fire characteristics,
VDE 250-214

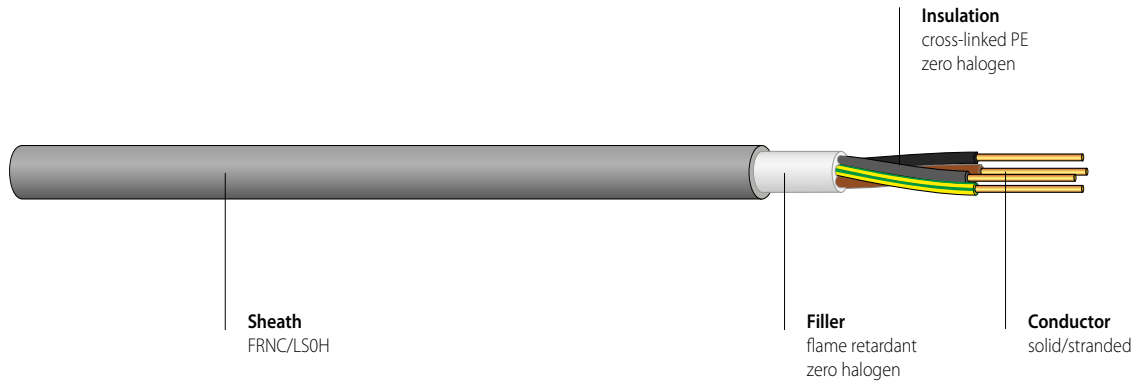

PRODUCT INFORMATION



APPLICATION For permanent installation in dry, damp or wet areas, on or behind plasterwork or in walls or concrete, except for direct embedding in cast, rammed or vibrated concrete. Also suitable for outdoor applications. Permitted operating temperature at conductor of +70°C.

CONSTRUCTION	Conductor	Bare copper, solid or stranded, IEC 60228, EN 60228, (VDE 0295)
	Insulation	Cross-linked Polyethylene, CENELEC HD 604 S1 and VDE 0276-604 "2X11"
	Filler	Halogen-free compound
	Outer sheath	Polyolefin compound, VDE 0250-214 "HM2"
	Core colours	CENELEC HD 308 S2 and VDE 0293
	Sheath colour	Grey
	Imprint	On request

TECHNICAL PROPERTIES	Nominal voltage	300/500V
	Test voltage	2000V, 50Hz

GENERAL PROPERTIES	Minimum bending radius	permanent installation	4 x D (D = outer diameter)
		during installation	6 x D
	Operating temperature	permanent installation	-40°C to +70°C
		during installation	+5°C to +50°C

	Zero halogen	
	non corrosive gases	IEC 60754-2, EN 50267-2-2, VDE 0482-267-2-2
	Flame propagation	IEC 60332-1-2, EN 60332-1-2, VDE 0482-332-1-2
	Flame spread	IEC 60332-3-24 Cat. C, EN 60332-3-24 Cat. C, VDE 0482-332-3-24 Cat. C
	Smoke density	IEC 61034-1/-2, EN 61034-1/-2, VDE 0482-1034-1/-2

PRODUCT INFORMATION

Article No.	No. of cores x cross section				Cu content kg/km	Total weight approx. kg/km	Outer diameter approx. mm	Fire load approx. kWh/m
	n x mm ²							
154675	2	x	1.5	RE	29	100	8.5	0.33
154676	2	x	2.5	RE	48	115	9.0	0.40
149254	3	x	1.5	RE	43	110	9.0	0.33
154369	3	x	2.5	RE	72	145	9.5	0.38
154677	3	x	4	RE	115	230	12.0	0.59
154678	3	x	6	RE	173	300	13.0	0.68
173842	3	x	10	RE	288	510	16.0	1.08
154367	4	x	1.5	RE	58	130	9.5	0.38
154679	4	x	2.5	RE	96	200	10.5	0.46
154680	4	x	4	RE	154	290	12.5	0.70
154681	4	x	6	RE	230	390	14.0	0.83
174718	4	x	10	RE	384	620	17.0	1.25
154368	5	x	1.5	RE	72	150	10.0	0.44
154370	5	x	2.5	RE	120	205	11.0	0.50
154371	5	x	4	RE	192	340	13.5	0.81
154372	5	x	6	RE	288	455	15.0	0.93
169929	5	x	10	RE	480	730	18.5	1.44
169930	5	x	16	RM	768	1150	22.5	2.06
154682	7	x	1.5	RE	101	195	10.5	0.55
154683	7	x	2.5	RE	168	285	12.5	0.74
174719	10	x	1.5	RE	144	330	14.5	0.92
156849	12	x	1.5	RE	173	345	15.0	0.95
174720	24	x	1.5	RE	346	610	19.5	1.65

RE = circular, solid conductor

RM = circular, stranded conductor

Additional dimensions available on request.

PREVENTIVE FIRE PROTECTION

(N)HXM(St)H

Shielded power cable 300/500V

halogen-free, with improved fire characteristics,
VDE 0250-214

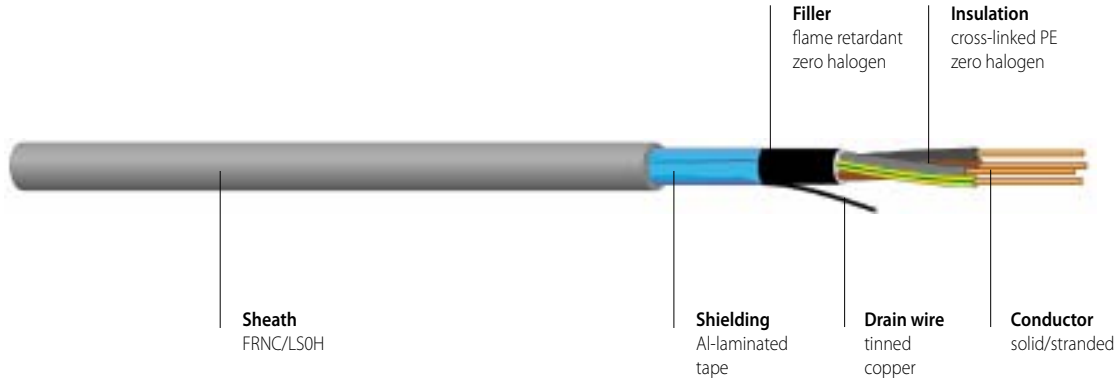

PRODUCT INFORMATION



APPLICATION

For permanent installation in dry, damp or wet areas, on or behind plasterwork or in walls or concrete, except for direct embedding in cast, rammed or vibrated concrete. Also suitable for outdoor applications. Permitted operating temperature at conductor of +70°C.

CONSTRUCTION

Conductor	Bare copper, solid or stranded, IEC 60228, EN 60228, (VDE 0295)
Insulation	Cross-linked Polyethylene, CENELEC HD 604 S1 and VDE 0276-604 "2X11"
Filler	Halogen-free compound
Shielding	Al-laminated tape with tinned copper drain wire
Outer sheath	Polyolefin compound, VDE 0250-214 "HM2"
Core colours	CENELEC HD 308 S2, (VDE 0293)
Sheath colour	Grey
Imprint	On request

TECHNICAL PROPERTIES

Nominal voltage	300/500V
Test voltage	2000V, 50Hz

GENERAL PROPERTIES

Minimum bending radius	permanent installation	4 x D (D = outer diameter)
	during installation	6 x D
Operating temperature	permanent installation	-40°C to +70°C
	during installation	+5°C to +50°C

Zero halogen	IEC 60754-2, EN 50267-2-2, VDE 0482-267-2-2 IEC 60332-1-2, EN 60332-1-2, VDE 0482-332-1-2 IEC 60332-3-24 Cat. C, EN 60332-3-24 Cat. C, VDE 0482-332-3-24 Cat. C IEC 61034-1/-2, EN 61034-1/-2, VDE 0482-1034-1/-2
non corrosive gases	
Flame propagation	
Flame spread	
Smoke density	

PRODUCT INFORMATION

Article No.	No. of cores x cross section				Cu content kg/km	Total weight approx. kg/km	Outer diameter approx. mm	Fire load approx. kWh/m
	n x mm ²							
	2	x	1.5	RE	43	119	8.5	0.26
	2	x	2.5	RE	63	151	9.7	0.32
1301193	3	x	1.5	RE	58	137	9.0	0.36
1301194	3	x	2.5	RE	87	180	10.0	0.42
1301212	4	x	1.5	RE	72	160	10.0	0.41
1301213	4	x	2.5	RE	111	213	11.0	0.48
1301214	5	x	1.5	RE	87	187	11.0	0.48
1301195	5	x	2.5	RE	135	253	12.0	0.56

RE = circular, solid conductor
RM = circular, stranded conductor

Additional dimensions available on request.

PREVENTIVE FIRE PROTECTION

N2XH

Safety cable 0.6/1kV

Halogen-free, with improved fire characteristics,
CENELEC HD 604 S1, VDE 0276-604

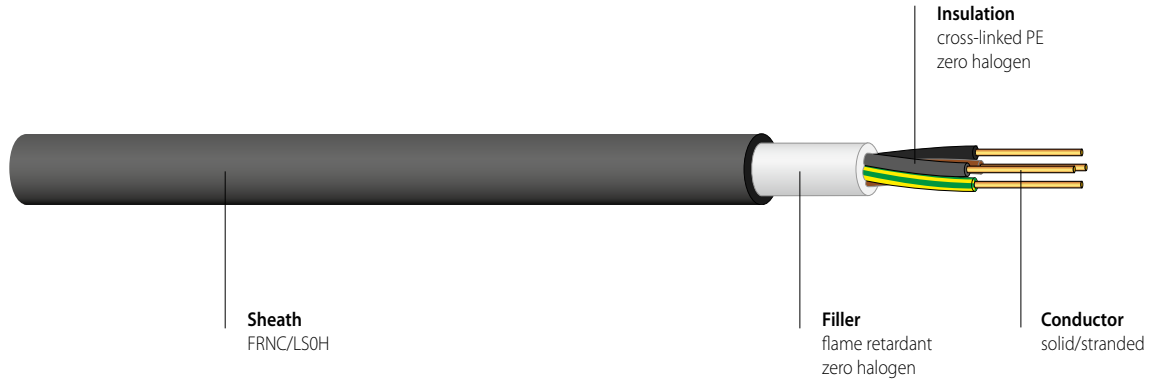

PRODUCT INFORMATION



APPLICATION For permanent installation in dry, damp or wet areas, on or behind plasterwork or in walls or concrete. Also suitable for outdoor applications. The cable should only be laid directly in earth or water if a protective conduit is used. Permitted operating temperature at conductor of +90°C.

CONSTRUCTION	Conductor	Bare copper, solid or stranded, IEC 60228, EN 60228 (VDE 0295)
	Insulation	Cross-linked Polyethylene, CENELEC HD 604 S1 and VDE 0276-604
	Filler	Halogen-free compound or plastic tape
	Outer sheath	Polyolefin compound, CENELEC HD 604 S1, VDE 0276-604 "HM4"
	Core colours	CENELEC HD 308 S2 and VDE 0293
	Sheath colour	Black
	Imprint	On request

ELECTRICAL PROPERTIES	Nominal voltage	0.6/1kV
	Test voltage	4000V, 50Hz

GENERAL PROPERTIES	Minimum bending radius	during and permanent installation	15* x D (single core cable) 12* x D (multicore cable) (D = outer diameter)
		permanent installation	*50% reduction if installation at 30°C and with a template
	Operating temperature	permanent installation	-45°C to +90°C
		during installation	-5°C to +50°C

Zero halogen	IEC 60754-2, EN 50267-2-2, VDE 0482-267-2-2
non corrosive gases	IEC 60332-1-2, EN 60332-1-2, VDE 0482-332-1-2
Flame propagation	IEC 60332-3-22/-24 Cat. A/C, EN 60332-3-22/-24 Cat. A/C,
Flame spread	VDE 0482-332-3-22/-24 Cat. A/C
Smoke density	IEC 61034-1/-2, EN 61034-1/-2, VDE 0482-1034-1/-2

Safety cables

Support systems

Fixing devices

Distribution boxes

Accessories

Information

N2XH0513/e

PRODUCT INFORMATION

Article No.	No. of cores x cross section			Core colours	Cu content kg/km	Total weight approx. kg/km	Outer diameter approx. mm	Fire load approx. kWh/m
	n	x	mm ²					
170000	1	x	4 RE	black	38	75	6.4	0.20
170022	1	x	4 RE	green/yellow	38	75	6.4	0.20
170001	1	x	6 RE	black	58	97	6.9	0.22
170002	1	x	6 RE	green/yellow	58	97	6.9	0.22
170015	1	x	10 RE	black	96	140	7.7	0.26
170023	1	x	10 RE	green/yellow	96	140	7.7	0.26
170003	1	x	16 RM	black	154	202	9.1	0.36
170014	1	x	16 RM	green/yellow	154	202	9.1	0.36
170004	1	x	25 RM	black	240	302	11.0	0.48
170005	1	x	25 RM	green/yellow	240	302	11.0	0.48
170010	1	x	35 RM	black	336	397	12.0	0.55
170026	1	x	35 RM	green/yellow	336	397	12.0	0.55
170006	1	x	50 RM	black	480	523	13.0	0.65
170007	1	x	50 RM	green/yellow	480	523	13.0	0.65
170018	1	x	70 RM	black	672	745	15.0	0.84
170030	1	x	70 RM	green/yellow	672	745	15.0	0.84
170008	1	x	95 RM	black	912	986	17.0	0.97
170009	1	x	95 RM	green/yellow	912	986	17.0	0.97
170019	1	x	120 RM	black	1152	1214	18.0	1.10
170025	1	x	120 RM	green/yellow	1152	1214	18.0	1.10
170020	1	x	150 RM	black	1440	1536	21.0	1.43
191566	1	x	150 RM	green/yellow	1440	1536	21.0	1.43
170011	1	x	185 RM	black	1776	1888	23.0	1.72
170031	1	x	185 RM	green/yellow	1776	1888	23.0	1.72
170012	1	x	240 RM	black	2304	2472	26.0	2.02
170016	1	x	240 RM	green/yellow	2304	2472	26.0	2.02
170013	1	x	300 RM	black	2880	2945	28.0	2.34
170029	1	x	300 RM	green/yellow	2880	2945	28.0	2.34

RE = circular, solid conductor
RM = circular, stranded conductor

Additional dimensions available on request.

PREVENTIVE FIRE PROTECTION

N2XH

Safety cable 0.6/1kV

halogen-free, with improved fire characteristics,
CENELEC HD 604 S1, VDE 0276-604

PRODUCT INFORMATION



Article No.	No. of cores x cross section				Cu content kg/km	Total weight approx. kg/km	Outer diameter approx. mm	Fire load approx. kWh/m
	n	x	mm ²	RE				
190524	2	x	1.5	RE	29	120	8.0	0.38
188201	3	x	1.5	RE	43	135	9.0	0.44
188204	3	x	2.5	RE	72	181	10.0	0.51
188349	3	x	4	RE	115	242	11.0	0.60
188210	3	x	6	RE	173	319	12.5	0.70
190505	3	x	10	RE	288	464	14.0	0.83
188216	3	x	16	RM	461	697	17.0	1.22
188202	4	x	1.5	RE	58	163	10.0	0.52
188205	4	x	2.5	RE	96	214	11.0	0.60
188208	4	x	4	RE	154	294	12.0	0.72
188211	4	x	6	RE	230	390	14.0	0.83
188214	4	x	10	RE	384	586	16.0	1.03
188217	4	x	16	RM	614	874	19.0	1.50
188219	4	x	25	RM	960	1332	23.0	2.14
188028	4	x	35	RM	1344	1777	26.0	2.57
188222	4	x	50	RM	1920	2343	29.0	3.15
188030	4	x	70	RM	2688	3384	35.0	4.17
188224	4	x	95	RM	3648	4490	39.0	5.16

RE = circular, solid conductor
RM = circular, stranded conductor

Additional dimensions available on request.

PRODUCT INFORMATION

Article No.	No. of cores x cross section				Cu content kg/km	Total weight approx. kg/km	Outer diameter approx. mm	Fire load approx. kWh/m
	n x mm ²							
188203	5	x	1.5	RE	72	193	11.0	0.62
188206	5	x	2.5	RE	120	256	12.0	0.71
188357	5	x	4	RE	192	352	13.0	0.85
188358	5	x	6	RE	288	475	15.0	0.99
188215	5	x	10	RE	480	708	17.0	1.22
188218	5	x	16	RM	768	1081	21.0	1.87
188220	5	x	25	RM	1200	1631	25.5	3.32
170095	7	x	1.5	RE	101	230	12.0	0.73
170096	7	x	2.5	RE	168	315	13.0	0.85
170104	10	x	1.5	RE	144	326	15.0	1.03
170105	10	x	2.5	RE	240	447	16.0	1.20
170099	12	x	1.5	RE	173	365	15.0	1.14
170106	12	x	2.5	RE	288	510	17.0	1.33
170107	14	x	1.5	RE	202	420	16.0	1.27
170100	19	x	1.5	RE	274	511	18.0	1.58
170101	24	x	1.5	RE	346	664	21.0	2.06
170108	30	x	1.5	RE	432	793	22.0	2.41

RE = circular, solid conductor
RM = circular, stranded conductor

Additional dimensions available on request.

PREVENTIVE FIRE PROTECTION

N2XCH

Safety cable 0.6/1kV

halogen-free, with improved fire characteristics,
CENELEC HD 604 S1, VDE 0276-604

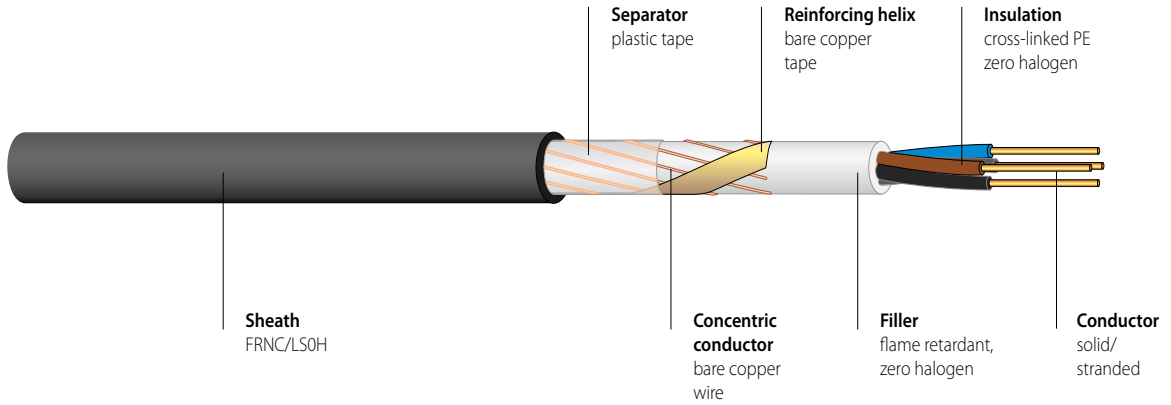

PRODUCT INFORMATION



APPLICATION

For permanent installation in dry, damp or wet areas, on or behind plasterwork or in walls or concrete. Also suitable for outdoor applications. The cable should only be laid directly in earth or water if a protective conduit is used. Permitted operating temperature at conductor of +90°C.

CONSTRUCTION

Conductor	Bare copper, solid or stranded, IEC 60228, EN 60228, (VDE 0295)
Insulation	Cross-linked Polyethylene, CENELEC HD 604 S1, VDE 0276-604
Filler	Halogen-free compound or plastic tape
Concentric conductor	Bare copper wires with reinforced helix
Separator	Plastic tape
Outer sheath	Polyolefin compound, CENELEC HD 604 S1 and VDE 0276-604 "HM4"
Core colours	CENELEC HD 308 S2 and VDE 0293
Sheath colour	Black
Imprint	On request

ELECTRICAL PROPERTIES

Nominal voltage	0.6/1kV
Test voltage	4000V, 50Hz

GENERAL PROPERTIES

Minimum bending radius	during and permanent installation	12 x D (multicore cable) (D = outer diameter)
Operating temperature	permanent installation	-45°C to +90°C
	during installation	-5°C to +50°C

Zero halogen	IEC 60754-2, EN 50267-2-2, VDE 0482-267-2-2
non corrosive gases	IEC 60332-1-2, EN 60332-1-2, VDE 0482-332-1-2
Flame propagation	IEC 60332-3-22/-24 Cat. A/C, EN 60332-3-22/-24 Cat. A/C,
Flame spread	VDE 0482-332-3-22/-24 Cat. A/C
Smoke density	IEC 61034-1/-2, EN 61034-1/-2, VDE 0482-1034-1/-2

PRODUCT INFORMATION

Article No.	No. of cores x cross section		Cu content kg/km	Total weight approx. kg/km	Outer diameter approx. mm	Fire load approx. kWh/m
	n	n x mm ²				
188225	2	x 1.5 RE/1,5	52	162	11.0	0.43
188228	2	x 2.5 RE/2,5	80	206	12.0	0.49
188226	3	x 1.5 RE/1,5	66	180	11.0	0.48
188229	3	x 2.5 RE/2,5	104	234	12.0	0.55
188231	3	x 4 RE/4	161	319	14.0	0.65
188233	3	x 6 RE/6	240	430	15.0	0.75
188235	3	x 10 RE/10	408	611	17.0	0.94
188237	3	x 16 RM/16	643	924	20.0	1.47
188239	3	x 25 RM/16	902	1280	23.0	1.94
188241	3	x 35 RM/16	1190	1634	26.0	2.29
188243	3	x 50 RM/25	1723	2235	29.0	2.72
188227	4	x 1.5 RE/1,5	81	205	12.0	0.56
188230	4	x 2.5 RE/2,5	128	269	13.0	0.64
188232	4	x 4 RE/4	200	375	15.0	0.79
188234	4	x 6 RE/6	297	510	16.0	0.92
188236	4	x 10 RE/10	504	745	18.0	1.10
188238	4	x 16 RM/16	796	1107	21.0	1.75
188240	4	x 25 RM/16	1142	1572	25.0	2.36
188242	4	x 35 RM/16	1526	2013	28.0	2.75
188244	4	x 50 RM/25	2203	2759	32.0	3.38
188245	4	x 70 RM/35	3082	3899	38.0	4.48
188246	4	x 95 RM/50	4208	5164	42.0	5.44
188247	4	x 120 RM/70	5388	6494	46.0	6.38
188248	4	x 150 RM/70	6540	7959	52.0	7.97
188249	4	x 185 RM/95	8159	9932	57.0	9.86
188250	4	x 240 RM/120	10546	12989	65.0	12.01
170156	7	x 1.5 RE/2,5	133	286	14.0	0.78
170191	7	x 2.5 RE/2,5	200	373	15.0	0.89
170192	7	x 4 RE/4	315	532	17.0	1.11
170193	7	x 6 RE/6	470	727	18.0	1.25
170157	12	x 1.5 RE/2,5	205	429	17.0	1.18
170195	12	x 2.5 RE/4	334	600	19.0	1.40
170158	24	x 1.5 RE/6	413	790	23.0	2.14
170159	30	x 1.5 RE/6	499	921	25.0	2.52
170196	30	x 2.5 RE/10	840	1319	28.0	3.01

RE = circular, solid conductor, RM = circular, stranded conductor. Additional dimensions available on request.

PREVENTIVE FIRE PROTECTION

J-H(St)H...Bd

Wiring cable for telecommunication systems max. 300V

halogen-free, with improved fire characteristics,
VDE 0815

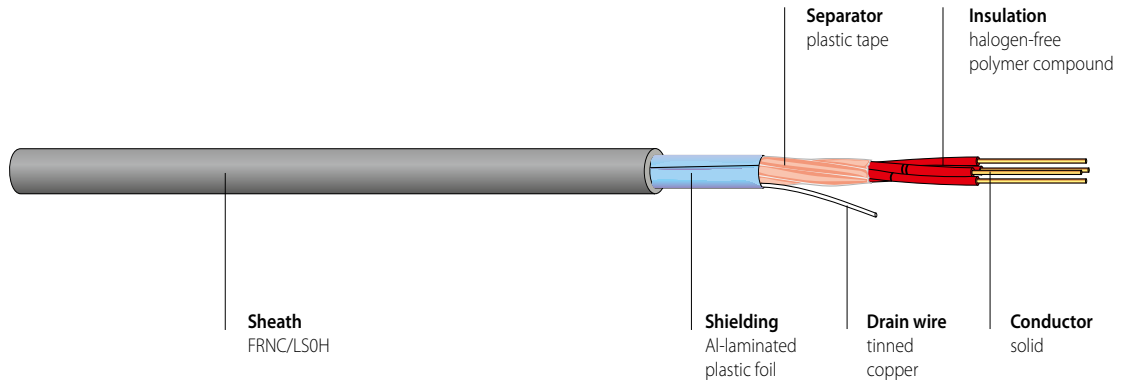

PRODUCT INFORMATION



APPLICATION

Installation cable with electrostatic shield for areas vulnerable to fire and with high concentration of people and property value. For ICT systems for lossless data and signal transmission. Suitable for laying in dry and humid rooms, on-wall and in-wall, also for outdoor use. No underground laying. Not to be used for high-voltage transmission. Permitted operating temperature at conductor of +70°C.

CONSTRUCTION

Conductor	Bare copper, solid, 0.6 or 0.8 mm diameter
Insulation	Halogen-free polymer compound, EN 50290-2-26
Core identification	DIN VDE 0815 (different colours)
Stranding	Cores twisted to star-quads and quads to units
Shielding	Al-laminated plastic foil with drain wire, copper tinned
Outer sheath	Halogen-free polymer compound, EN 50290-2-27
Sheath colour	Grey

ELECTRICAL PROPERTIES

Rated voltage	max. 300V
Test voltage	800V 50Hz
Conductor resistance	
Loop	0.6 mm max. 130 Ω/km
	0.8 mm max. 73,2 Ω/km
Insulation resistance	min. 100 MΩ x km
Capacity	max. 120 nF/km

GENERAL PROPERTIES

Minimum bending radius	permanent installation	2.5 x D
	during installation	7.5 x D
Operating temperature	permanent installation	-30 °C bis +70 °C
	during installation	- 5 °C bis +50 °C

- Zero halogen
- non corrosive gases IEC 60754-2, EN 50267-2-2, VDE 0482-267-2-2
- Flame propagation IEC 60332-1-2, EN 60332-1-2, VDE 0482-332-1-2
- Flame spread IEC 60332-3-24 Cat. C, EN 60332-3-24 Cat. C, VDE 0482-332-3-24 Cat. C
- Smoke density IEC 61034-1/-2, EN 61034-1/-2, VDE 0482-1034-1/-2

PRODUCT INFORMATION

Article No.	No. of cores x conductor diameter					Cu content kg/km	Total weight approx. kg/km	Outer diameter approx. mm	Fire load approx. kWh/m
	n x mm								
	1	x	2	x	0.6	9	33	5.0	0.90
152833	2	x	2	x	0.6	14	49	6.0	0.12
152834	4	x	2	x	0.6	25	92	9.0	0.18
152835	6	x	2	x	0.6	37	101	9.0	0.23
152836	10	x	2	x	0.6	59	146	11.0	0.33
152837	20	x	2	x	0.6	116	310	16.0	0.72
154450	30	x	2	x	0.6	172	352	17.0	0.81
1154451	40	x	2	x	0.6	229	464	19.0	1.05
154452	50	x	2	x	0.6	286	573	21.0	1.34
154453	60	x	2	x	0.6	342	661	23.0	1.50
154454	80	x	2	x	0.6	455	876	27.0	2.01
154455	100	x	2	x	0.6	568	1056	29.0	2.53
191001	1	x	2	x	0.8	15	56	6.0	0.12
152838	2	x	2	x	0.8	25	69	7.0	0.16
152689	4	x	2	x	0.8	45	136	11.0	0.29
152839	6	x	2	x	0.8	65	152	11.0	0.35
152840	10	x	2	x	0.8	106	230	13.0	0.55
152841	20	x	2	x	0.8	206	508	21.0	1.21
1159967	30	x	2	x	0.8	307	599	22.0	1.36
1172012	40	x	2	x	0.8	407	787	25.0	1.67
1172013	50	x	2	x	0.8	508	973	25.0	2.19
1172014	60	x	2	x	0.8	608	1121	30.0	2.44
1172015	80	x	2	x	0.8	809	1476	34.0	3.18
1172016	100	x	2	x	0.8	1010	1805	38.0	4.07

Additional dimensions available on request.

PREVENTIVE FIRE PROTECTION

J-H(St)H...Bd

Fire alarm cable max. 300V

halogen-free, with improved fire characteristics,
VDE 0815

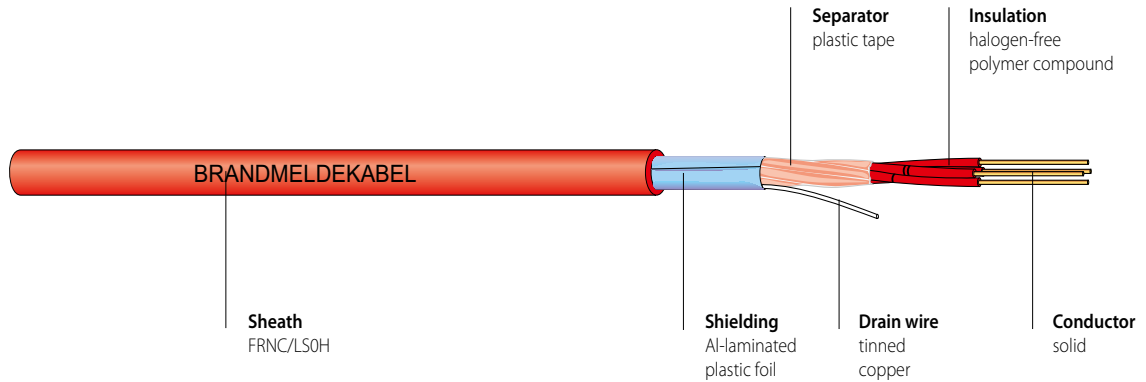

PRODUCT INFORMATION



APPLICATION

Installation cable with electrostatic shield for areas vulnerable to fire and with high concentration of people and property value. For ICT systems for lossless data and signal transmission. Suitable for laying in dry and humid rooms, on-wall and in-wall, also for outdoor use. No underground laying. Not to be used for high-voltage transmission. Permitted operating temperature at conductor of +70°C.

CONSTRUCTION

Conductor	Bare copper, solid, 0.6 or 0.8 mm diameter
Insulation	Halogen-free polymer compound, EN 50290-2-26
Core identification	DIN VDE 0815 (different colours)
Stranding	Cores twisted to star-quads and quads to units
Shielding	Al-laminated plastic foil with drain wire, copper tinned
Outer sheath	Halogen-free polymer compound, EN 50290-2-27
Sheath colour	Red

ELECTRICAL PROPERTIES

Rated voltage	max. 300V
Test voltage	800V 50Hz
Conductor resistance	
Loop	0.6 mm max. 130 Ω/km
	0.8 mm max. 73.2 Ω/km
Insulation resistance	min. 100 MΩ x km
Capacity	max. 120 nF/km

GENERAL PROPERTIES

Minimum bending radius	permanent installation	2.5 x D
	during installation	7.5 x D
Operating temperature	permanent installation	-30 °C bis +70 °C
	during installation	- 5 °C bis +50 °C

- Zero halogen
- non corrosive gases IEC 60754-2, EN 50267-2-2, VDE 0482-267-2-2
- Flame propagation IEC 60332-1-2, EN 60332-1-2, VDE 0482-332-1-2
- Flame spread IEC 60332-3-24 Cat. C, EN 60332-3-24 Cat. C, VDE 0482-332-3-24 Cat. C
- Smoke density IEC 61034-1/-2, EN 61034-1/-2, VDE 0482-1034-1/-2

Safety cables

Support systems

Fixing devices

Distribution boxes

Accessories

Information

J-H(St)H...Bd BMK 0513/e

PRODUCT INFORMATION

Article No.	No. of cores x conductor diameter				Cu content kg/km	Total weight approx. kg/km	Outer diameter approx. mm	Fire load approx. kWh/m
	n x mm							
184707	1	x	2	x 0.8	15	56	6.0	0.12
157892	2	x	2	x 0.8	25	69	7.0	0.16
157893	4	x	2	x 0.8	45	136	11.0	0.29
157894	6	x	2	x 0.8	65	152	11.0	0.35
157895	10	x	2	x 0.8	106	230	13.0	0.55
1172017	20	x	2	x 0.8	206	508	21.0	1.21
1172018	30	x	2	x 0.8	307	599	22.0	1.36
1172019	40	x	2	x 0.8	407	787	25.0	1.67
157406	50	x	2	x 0.8	508	973	25.0	2.19
1172020	60	x	2	x 0.8	608	1121	30.0	2.44
1172021	80	x	2	x 0.8	809	1476	34.0	3.18
1172022	100	x	2	x 0.8	1010	1805	38.0	4.07

Fire alarm cable with red sheath and imprint "Brandmeldekabel" (fire alarm cable).

Additional dimensions available on request.

PREVENTIVE FIRE PROTECTION

FE5-CL

Safety cable 0.6/1kV, armoured with rodent protection

halogen-free, with improved fire characteristics,
with reference to SEV TP 20B/3C
and CENELEC HD 604 S1 part 5. H

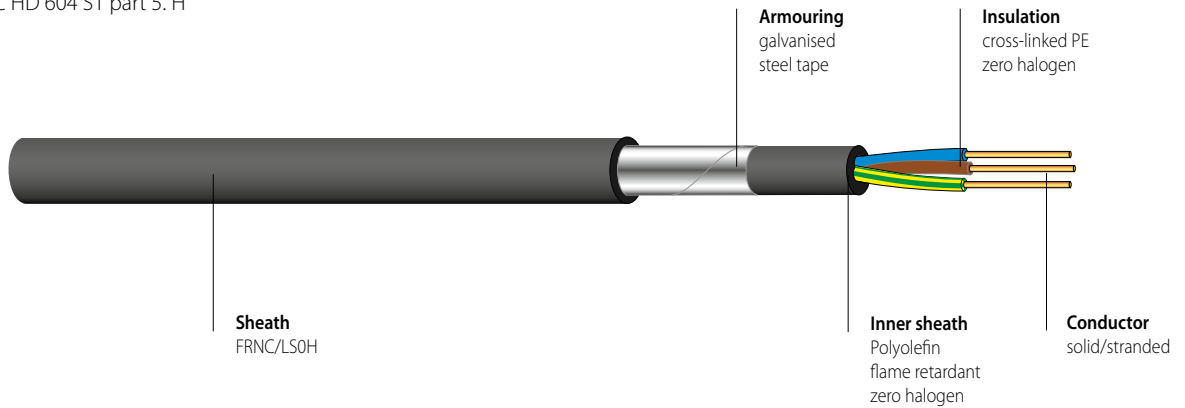

PRODUCT INFORMATION



APPLICATION

For permanent installation in dry, damp or wet areas, on or behind plasterwork or in walls or concrete. Also suitable for outdoor applications.
The cable should only be laid directly in earth or water if a protective conduit is used.
Permitted operating temperature at conductor of +90°C.

CONSTRUCTION

Conductor	Bare copper, solid or stranded, IEC 60228, EN 60228
Insulation	Cross-linked Polyethylene CENELEC HD 604 S1 part 5 sec. H
Inner sheath	Flame retardant Polyolefin compound CENELEC HD 604 S1 part 5 sec. H
Armouring/ rodent protection	Single core cable with copper tape (CLCU) and Multicore cable with galvanised steel tape (CL)
Outer sheath	Flame retardant Polyolefin compound CENELEC HD 604 S1 part 5 sec. H
Core colours	CENELEC HD 308 S2
Sheath colour	Black

ELECTRICAL PROPERTIES

Nominal voltage	0.6/1kV
Test voltage	3500V, 50Hz

GENERAL PROPERTIES

Minimum bending radius	during and permanent installation	15* x D (single core cable) 12* x D (multicore cable) (D = outer diameter)
Operating temperature	permanent installation during installation	-45°C to +90°C -5°C to +50°C

Zero halogen non corrosive gases	IEC 60754-2, EN 50267-2-2, VDE 0482-267-2-2 SEVTP 20B/3C 3.4.4
Flame propagation	IEC 60332-1-2, EN 60332-1-2, VDE 0482-332-1-2 SEVTP 20B/3C 3.4.1.1
Flame spread	IEC 60332-3-24 Cat. C, EN 60332-3-24 Cat. C, VDE 0482-332-3-24 Cat. C SEVTP 20B/3C 3.4.1.3
Smoke density	IEC 61034-1/-2, EN 61034-1/-2, VDE 0482-1034-1/-2 SEVTP 20B/3C 3.4.3

Safety cable 0.6/1kV, armoured with rodent protection

halogen-free, with improved fire characteristics,
with reference to SEV TP 20B/3C
and CENELEC HD 604 S1 part 5. H

PRODUCT INFORMATION

Article No.	No. of cores x cross section			Cu content kg/km	Total weight approx. kg/km	Outer diameter approx. mm	Fire load kWh/m
	n x mm ²						
	2	x	1.5 RE	29	173	10	0.30
	2	x	2.5 RE	48	170	10	0.40
	3	x	1.5 RE	43	171	10	0.33
191007	3	x	2.5 RE	72	190	11	0.43
191091	3	x	4 RE	115	240	12	0.53
191645	3	x	6 RE	173	350	14	0.72
191568	3	x	10 RE	288	515	16	0.96
	3	x	16 RM	461	770	20	1.55
191672	4	x	1.5 RE	58	189	10	0.38
	4	x	2.5 RE	96	220	11	0.50
	4	x	4 RE	154	305	13	0.62
	4	x	6 RE	230	420	15	0.80
	4	x	10 RE	384	630	17	1.08
	4	x	16 RM	614	1000	22	1.92
	4	x	25 RM	960	1450	26	2.53
	4	x	35 RM	1344	1950	30	3.26
191064	5	x	2.5 RE	120	270	12	0.61
192731	5	x	4 RE	192	375	14	0.77
190595	5	x	6 RE	288	510	16	0.96
188389	5	x	10 RE	480	760	19	1.31
	5	x	10 RM	480	820	21	1.53
190401	5	x	16 RM	768	1200	24	2.17
191063	5	x	25 RM	1200	1750	28	2.85
191090	5	x	35 RM	1680	2400	33	3.94
191036	5	x	50 RM	2400	3200	37	4.90
	5	x	70 RM	3360	4550	44	6.60
191600	5	x	95 RM	4560	6050	50	8.64
	7	x	1.5 RE	101	230	11	0.54
180930	7	x	2.5 RE	168	330	13	0.71
	7	x	4 RE	269	460	15	0.91
180929	7	x	6 RE	403	651	17	1.15
184531	7	x	10 RE	672	980	21	1.58
	8	x	1.5 RE	115	272	13	0.62
	8	x	2.5 RE	192	389	15	0.82
	10	x	1.5 RE	144	329	14	0.77
	10	x	2.5 RE	240	470	17	1.01
	12	x	1.5 RE	173	367	15	0.94
192240	12	x	2.5 RE	288	530	17	1.26
	21	x	2.5 RE	504	850	22	2.00
	27	x	2.5 RE	389	1050	24	2.16

RE = circular, solid conductor, RM = circular, stranded conductor

Additional dimensions available on request.

PREVENTIVE FIRE PROTECTION

FE180

Safety cable 0.6/1kV, Keram

halogen-free, with improved fire characteristics,
with reference to SEV TP 20B/3C and CENELEC HD 604 S1 part 5.H
30 minutes System Circuit Integrity* according to DIN 4102-12



PRODUCT INFORMATION



APPLICATION

Safety cables are installed in all areas that require special protection of people and equipment against fire and fire damages and where strict security requirements must be fulfilled. Suitable for indoor applications. For outdoor applications, protection must be provided against exposure to direct sunlight. The cable should only be laid directly in earth or water if a protective conduit is used. Permitted operating temperature at conductor of +90°C.

CONSTRUCTION

Conductor	Bare copper, solid or stranded, in accordance with IEC 60228 and EN 60228
Insulation	Special compound, HD 604 S1 part 5 H
Filler	HD 604 S1 part 5 H
Outer sheath	Compound, HD 604 S1 part 5 H
Core colours	CENELEC HD 308 S2
Sheath colour	Orange

ELECTRICAL PROPERTIES

Nominal voltage	0.6/1kV
Test voltage	3500V, 50Hz

GENERAL PROPERTIES

Minimum bending radius	during and permanent installation	15* x D (single-core cable) 12* x D (multicore cable) (D = outer diameter)
	permanent installation	*50% reduction if installation at 30°C and with a template
Operating temperature	permanent installation	-45°C to +90°C
	during installation	-5°C to +50°C

Zero halogen, non corrosive gases	IEC 60754-2, EN 50267-2-2, VDE 0482-267-2-2, SEV TP20B/3C 3.4.4
Flame propagation	IEC 60332-1-2, EN 60332-1-2, VDE 0482-332-1-2, SEV TP20B/3C 3.4.1.1
Flame spread	IEC 60332-3-23/-24 Cat. B/C, EN 60332-3-23/-24 Cat. B/C, VDE 0482-332-3-23/24 Cat. B/C, SEV TP20B/3C 3.4.1.3
Smoke density	IEC 61034-1/-2, EN 61034-1/-2, VDE 0482-1034-1/-2, SEV TP20B/3C 3.4.3
Circuit integrity (FE/PH)	IEC 60331-11/-21 (180minutes), VDE 0472 part 814 (FE180), SEV TP20B/3C 3.4.2
System Circuit Integrity E30*	according to DIN 4102 part 12 VKF Fire Safety Application No. 24176

* System Circuit Integrity is dependent on installation method

ACCESSORIES

To realize System Circuit Integrity E30, tested and certified fire safety system components are necessary.

PRODUCT INFORMATION

Article No.	No. of cores x cross section				Cu content kg/km	Total weight approx kg/km	Outer diameter approx mm	Fire load kWh/m
	n x mm ²							
171370	1	x	16	RM	154	227	9.8	0.34
171377	1	x	25	RM	240	329	11.3	0.43
171386	1	x	35	RM	336	428	12.4	0.48
171394	1	x	50	RM	480	565	13.9	0.58
171429	1	x	70	RM	672	783	15.7	0.68
170842	1	x	95	RM	912	1054	18.1	0.91
170845	1	x	120	RM	1152	1281	19.2	0.97
170850	1	x	150	RM	1440	1606	21.4	1.20
170855	1	x	185	RM	1776	1983	23.6	1.46
170858	1	x	240	RM	2304	2607	26.8	1.81
191118	2	x	1.5	RE	29	103	7.8	0.22
191119	2	x	2.5	RE	48	144	9.0	0.28
	2	x	4	RE	77	202	10.4	0.37
	2	x	6	RE	115	272	11.8	0.46
	2	x	10	RE	192	407	14.0	0.63
186952	2	x	16	RM	307	661	18.2	1.09
190404	2	x	25	RM	480	950	21.2	1.42
	2	x	35	RM	672	1219	23.4	1.66
	2	x	50	RM	960	1602	26.4	2.06
	2	x	70	RM	1334	2218	30.4	2.61
	2	x	95	RM	1824	2974	35.0	3.46
	2	x	120	RM	2304	3563	37.4	3.87
	2	x	150	RM	2880	4450	41.6	4.75
	2	x	185	RM	3552	5514	46.2	5.86
	2	x	240	RM	4608	7232	52.6	7.46
187180	3	x	1.5	RE	43	122	8.3	0.25
187184	3	x	2.5	RE	72	171	9.5	0.31
187187	3	x	4	RE	115	243	11.0	0.41
187189	3	x	6	RE	173	333	12.5	0.51
	3	x	10	RE	288	502	14.8	0.69
186953	3	x	16	RM	461	811	19.3	1.19
186955	3	x	25	RM	720	1184	22.6	1.56
186957	3	x	35	RM	1008	1529	24.9	1.80
186959	3	x	50	RM	1440	2026	28.2	2.24
186961	3	x	70	RM	2016	2844	32.7	2.88

RE = circular, solid conductor
RM = circular, stranded conductor

Additional dimensions available on request.

PREVENTIVE FIRE PROTECTION

FE180

Safety cable 0.6/1kV, Keram

halogen-free, with improved fire characteristics,
with reference to SEV TP 20B/3C and CENELEC HD 604 S1 part 5.H
30 minutes System Circuit Integrity* according to DIN 4102-12

PRODUCT INFORMATION



Article No.	No. of cores x cross section		Cu content	Total weight	Outer diameter	Fire load
	n	x mm ²				
187182	4	x 1.5 RE	58	148	9.1	0.29
190502	4	x 2.5 RE	96	212	10.5	0.38
192352	4	x 4 RE	154	304	12.2	0.49
192353	4	x 6 RE	230	414	13.8	0.61
	4	x 10 RE	384	635	16.4	0.85
186967	4	x 16 RM	614	1009	21.1	1.40
186968	4	x 25 RM	960	1485	24.8	1.86
186969	4	x 35 RM	1344	1929	27.4	2.15
186970	4	x 50 RM	1920	2600	31.5	2.79
186971	4	x 70 RM	2688	3618	36.2	3.38
186972	4	x 95 RM	3648	4860	41.7	4.68
186973	4	x 120 RM	4608	5890	44.6	5.19
186974	4	x 150 RM	5760	7417	50.0	6.52
187548	4	x 185 RM	7104	9164	55.3	7.98
187077	4	x 240 RM	9216	12029	63.0	10.05
187183	5	x 1.5 RE	72	178	9.9	0.35
187186	5	x 2.5 RE	120	261	11.6	0.47
187188	5	x 4 RE	192	371	13.4	0.61
187190	5	x 6 RE	288	509	15.2	0.76
	5	x 10 RE	480	777	18.1	1.03
186975	5	x 16 RM	768	1223	23.1	1.67
186976	5	x 25 RM	1200	1806	27.2	2.22
186977	5	x 35 RM	1680	2384	30.5	2.66
186978	5	x 50 RM	2400	3187	34.8	3.41
186979	5	x 70 RM	3360	4440	40.0	4.26
190587	5	x 95 RM	4560	6032	46.6	5.89
	5	x 120 RM	5760	7290	49.7	6.49
	5	x 150 RM	7200	9145	55.5	8.08
	5	x 185 RM	8880	11284	61.3	9.84
	5	x 240 RM	11520	14632	69.8	12.44

RE = circular, solid conductor
RM = circular, stranded conductor

Additional dimensions available on request.

PRODUCT INFORMATION

Article No.	No. of cores x cross section				Cu content kg/km	Total weight approx. kg/km	Outer diameter approx. mm	Fire load kWh/m
	n x mm ²							
186267	7	x	1.5	RE	101	222	10.8	0.41
186268	7	x	2.5	RE	168	322	12.5	0.53
	7	x	4	RE	269	464	14.5	0.7
187201	7	x	6	RE	403	652	16.7	0.89
	7	x	10	RE	672	1022	20.3	1.27
187108	8	x	1.5	RE	115	260	11.9	0.48
	8	x	2.5	RE	192	384	13.8	0.62
188345	10	x	1.5	RE	144	321	13.8	0.69
	10	x	2.5	RE	240	465	16.0	0.77
186269	12	x	1.5	RE	173	365	14.2	0.66
192479	12	x	2.5	RE	288	541	16.7	0.88
187109	21	x	1.5	RE	303	580	17.7	0.99
	21	x	2.5	RE	504	883	21.0	1.35
190412	27	x	1.5	RE	389	755	20.4	1.3
	27	x	2.5	RE	648	1122	23.9	1.7

RE = circular, solid conductor
RM = circular, stranded conductor

Additional dimensions available on request.

PREVENTIVE FIRE PROTECTION

FE180 flex

Control cable flex 300/500V, Keram

halogen-free, with improved fire characteristics,
with reference to SEV TP 20B/3C and CENELEC HD 604 S1 part 5.H

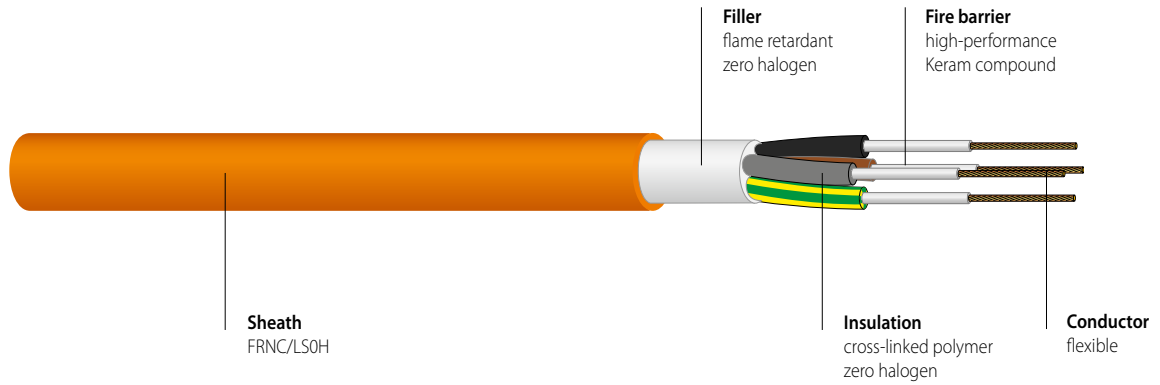

PRODUCT INFORMATION



APPLICATION

Safety cables are installed in all areas that require special protection of people and equipment against fire and fire damages and where strict security requirements must be fulfilled. Suitable for indoor applications. For outdoor applications, protection must be provided against exposure to direct sunlight. The cable should only be laid directly in earth or water if a protective conduit is used. Permitted operating temperature at conductor of +90°C.

CONSTRUCTION

Conductor	Bare copper, flexible, IEC 60228 class 5, EN 60228
Insulation	Special compound, HD 604 S1 part 5 H
Filler	HD 604 S1 part 5 H
Outer sheath	Compound, HD 604 S1 part 5 H
Core colours	CENELEC HD 308 S2
Sheath colour	Orange

ELECTRICAL PROPERTIES

Nominal voltage	300/500V
Test voltage	2000V, 50Hz

GENERAL PROPERTIES

Minimum bending radius	permanent installation	4 x D (D = outer diameter)
	during installation	6 x D
Operating temperature	permanent installation	-45°C to +90°C
	during installation	-5°C to +50°C

Zero halogen, non corrosive gases	IEC 60754-2, EN 50267-2-2, VDE 0482-267-2-2, SEVTP20B/3C 3.4.4
Flame propagation	IEC 60332-1-2, EN 60332-1-2, VDE 0482-332-1-2, SEVTP20B/3C 3.4.1.1
Flame spread	IEC 60332-3-24 Cat. C, EN 60332-3-24 Cat.C, VDE 0482-332-3-24 Cat. C, SEVTP20B/3C 3.4.1.3
Smoke density	IEC 61034-1/-2, EN 61034-1/-2, VDE 0482-1034-1/-2, SEVTP20B/3C 3.4.3
Circuit integrity (FE/PH)	IEC 60331-11/-21 (180minutes) , VDE 0472 part 814 (FE180), SEVTP20B/3C 3.4.2

PRODUCT INFORMATION

Article No.	No. of cores x cross section		Cu content kg/km	Total weight approx. kg/km	Outer diameter approx. mm	Fire load kWh/m
	n	n x mm ²				
188335	3	x 1.5	43	123	9	0.27
	4	x 4.0	154	345	14	0.54
187554	5	x 1.5	72	182	10	0.4
187179	5	x 2.5	120	268	12	0.55
	5	x 4.0	192	419	15	0.65
	5	x 6.0	288	580	18	0.80
192367	7	x 1.5	101	221	11	0.44
185228	8	x 1.5	115	272	13	0.56
191059	12	x 1.5	173	310	14	0.72
191060	16	x 1.5	231	406	16	0.89
191061	21	x 1.5	303	521	18	1.10

Additional dimensions available on request.

PREVENTIVE FIRE PROTECTION

FE180-CL

Safety cable 0.6/1kV armoured with rodent protection, Keram

halogen-free, with improved fire characteristics,
with reference to SEV TP 20B/3C and CENELEC HD 604 S1 part 5.H

30 minutes System Circuit Integrity*
according to DIN 4102-12

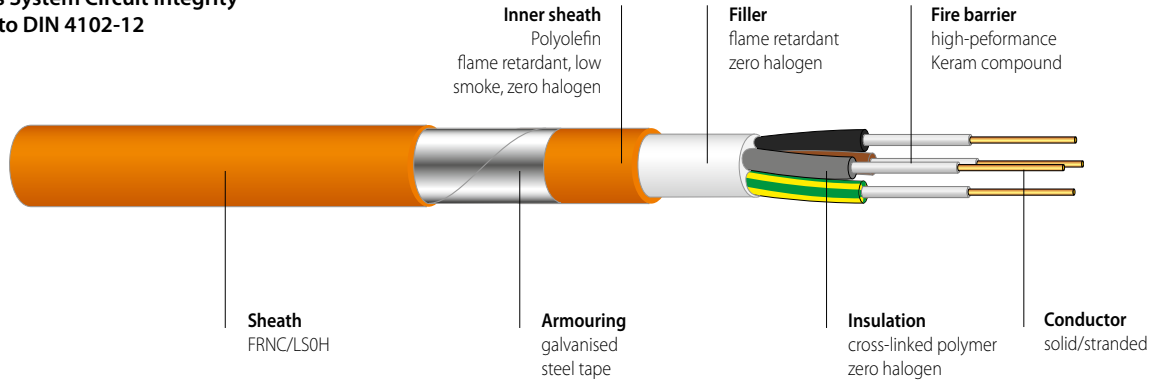

PRODUCT INFORMATION



APPLICATION

Safety cables are installed in all areas that require special protection of people and equipment against fire and fire damages and where strict security requirements must be fulfilled. Suitable for indoor applications. For outdoor applications, protection must be provided against exposure to direct sunlight. The cable should only be laid directly in earth or water if a protective conduit is used. Permitted operating temperature at conductor of +90°C.

CONSTRUCTION

Conductor	Bare copper, solid or stranded, IEC 60228 and EN 60228
Insulation	Special compound, HD 604 S1 part 5 H
Filler	HD 604 S1 part 5 H
Inner sheath	Compound, HD 604 S1 part 5 H
Armouring (rodent protection)	Single-core cable with copper tape (CLCU) and multicore cable with galvanised steel tape (CL)
Outer sheath	Compound, HD 604 S1 part 5 H
Core colours	CENELEC HD 308 S2
Sheath colour	Orange

ELECTRICAL PROPERTIES

Nominal voltage	0.6/1kV
Test voltage	3500V, 50Hz

GENERAL PROPERTIES

Minimum bending radius	during and permanent installation	15 x D (single core cable) 12 x D (multicore cable) (D = outer diameter)
Operating temperature	permanent installation during installation	-45°C to +90°C -5°C to +50°C
Zero halogen, non corrosive gases		IEC 60754-2, EN 50267-2-2, VDE 0482-267-2-2, SEVTP20B/3C 3.4.4
Flame propagation		IEC 60332-1-2, EN 60332-1-2, VDE 0482-332-1-2, SEVTP20B/3C 3.4.1.1
Flame spread		IEC 60332-3-24 Cat. C, EN 60332-3-24 Cat. C, VDE 0482-332-3-24 Cat. C, SEVTP20B/3C 3.4.1.3
Smoke density		IEC 61034-1/-2, EN 61034-1/-2, VDE 0482-1034-1/-2, SEVTP20B/3C 3.4.3
Circuit integrity (FE/PH)		IEC 60331-11/-21 (180minutes), VDE 0472 part 814 (FE180), SEVTP20B/3C 3.4.2
System Circuit Integrity E30*		according to DIN 4102 part 12 VKF Fire Safety Application No. 24176

* System Circuit Integrity is dependent on installation method

ACCESSORIES

To realize System Circuit Integrity E30, tested and certified fire safety system components are necessary.

PRODUCT INFORMATION

Article No.	No. of cores x cross section			Cu content	Total weight	Outer diameter	Fire load
	n x mm ²						
	3	x	1.5 RE	43	211	11	0.46
187199	3	x	2.5 RE	72	256	12	0.50
191097	3	x	4.0 RE	115	373	14	0.69
191121	3	x	6.0 RE	173	487	16	0.90
188354	3	x	10 RE	288	656	18	1.20
188327	3	x	16 RM	461	1075	24	1.93
	3	x	25 RM	720	1491	27	2.41
	3	x	35 RM	1008	1865	29	2.73
	3	x	50 RM	1440	2404	32	3.29
	3	x	70 RM	2016	3314	37	4.22
	3	x	95 RM	2736	4369	42	5.42
	3	x	120 RM	3456	5222	45	6.04
	3	x	150 RM	4320	6460	50	7.30

RE = circular, solid conductor
 RM = circular, stranded conductor

Additional dimensions available on request.

PREVENTIVE FIRE PROTECTION

FE180-CL

Safety cable 0.6/1kV armoured with rodent protection, Keram
 halogen-free, with improved fire characteristics,
 with reference to SEV TP 20B/3C and CENELEC HD 604 S1 part 5.H
30 minutes System Circuit Integrity*
 according to DIN 4102-12

PRODUCT INFORMATION



Article No.	No. of cores x cross section				Cu content kg/km	Total weight approx. kg/km	Outer diameter approx. mm	Fire load kWh/m
	n x mm ²							
.....	4	x	1.5	RE	58	251	12	0.54
191595	4	x	2.5	RE	96	336	14	0.56
187167	4	x	4	RE	154	454	16	0.79
188352	4	x	6	RE	230	538	17	1.06
.....	4	x	10	RE	384	872	21	1.48
186980	4	x	16	RM	614	1296	25	2.20
186981	4	x	25	RM	960	1820	29	2.78
186982	4	x	35	RM	1344	2296	32	3.16
190589	4	x	50	RM	1920	3035	36	4.02
192488	4	x	70	RM	2688	4044	40	5.05
192429	4	x	95	RM	3648	5426	46	6.52
192430	4	x	120	RM	4608	6494	49	7.26
.....	4	x	150	RM	5760	8140	54	8.72
.....	5	x	1.5	RE	72	260	12	0.58
191038	5	x	2.5	RE	120	360	14	0.76
188350	5	x	4	RE	192	489	16	1.05
188353	5	x	6	RE	288	647	18	1.28
188397	5	x	10	RE	480	971	21	1.76
187154	5	x	16	RM	768	1536	27	2.53
186984	5	x	25	RM	1200	2171	31	3.23
187132	5	x	35	RM	1680	2808	35	3.85
187131	5	x	50	RM	2400	3686	39	4.83
.....	5	x	70	RM	3360	5053	45	6.05
.....	5	x	95	RM	4560	6792	52	8.14

RE = circular, solid conductor
 RM = circular, stranded conductor

Additional dimensions available on request.

Safety cables

Support systems

Fixing devices

Distribution boxes

Accessories

Information

PRODUCT INFORMATION

Article No.	No. of cores x cross section				Cu content kg/km	Total weight approx. kg/km	Outer diameter approx. mm	Fire load kWh/m
	n x mm ²							
	7	x	1.5	RE	101	349	14	0.72
	7	x	2.5	RE	168	481	16	0.91
	7	x	4	RE	269	655	18	1.15
188355	7	x	6	RE	403	803	19	1.53
188356	7	x	10	RE	672	1214	23	2.13
192461	8	x	1.5	RE	115	406	15	0.85
187128	8	x	2.5	RE	192	493	16	1.04
191104	8	x	4	RE	308	684	18	1.36
	10	x	1.5	RE	144	498	18	1.05
	10	x	2.5	RE	240	677	20	1.32
	12	x	1.5	RE	173	546	18	1.12
	12	x	2.5	RE	288	781	21	1.52
	21	x	1.5	RE	303	849	22	1.71
	21	x	2.5	RE	504	1218	26	2.29
	27	x	1.5	RE	389	1075	25	2.16
	27	x	2.5	RE	648	1527	29	2.87

RE = circular, solid conductor
RM = circular, stranded conductor

Additional dimensions available on request.

PREVENTIVE FIRE PROTECTION

Standard Fire Safety Cable

Fire alarm cable 300/500V

halogen-free, with improved fire characteristics,
BS 7629-1 and BS 5839-1

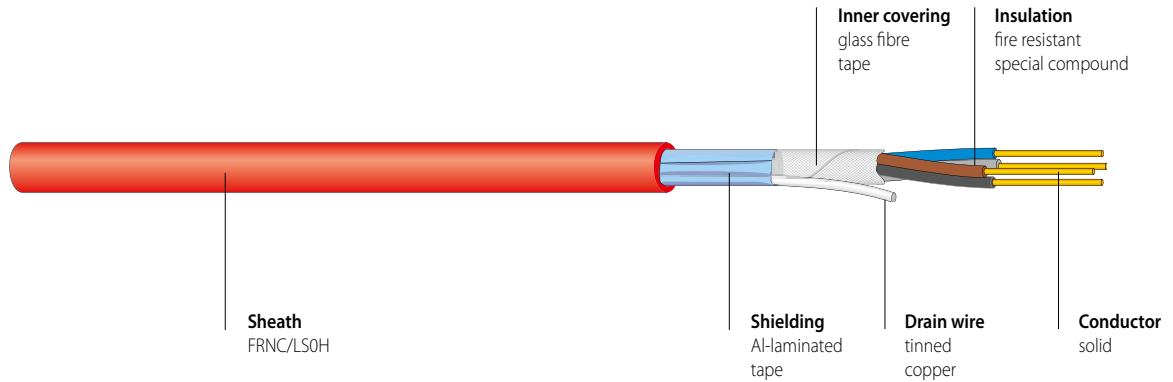

PRODUCT INFORMATION



APPLICATION Cable for fire alarm systems and emergency lighting, for permanent installation in buildings. Permitted operating temperature at conductor of +90°C.

CONSTRUCTION





Conductor	Bare copper, solid, IEC 60228 and EN 60228
Insulation	Special compound, BS EN 50363-5
Core colours	2 cores + earth: blue, brown 3 cores + earth: brown, black, grey 4 cores + earth: blue, brown, black, grey
Inner covering	Glass fibre tape
Shielding	Al-laminated tape and tinned copper drain wire IEC 60228, EN 60228
Separator	Plastic tape
Sheath	Polyolefin compound, BS 7655, "LTS3"
Sheath colour	Red, white (other colours on request)

ELECTRICAL PROPERTIES

Nominal voltage	300/500V
Test voltage	2000V, 50Hz

GENERAL PROPERTIES

Minimum bending radius	during and permanent installation	6 x D (D = outer diameter)
Operating temperature	permanent installation	-15°C to +90°C
	during installation	-5°C to +50°C

-  Zero halogen, non corrosive gases
 -  Flame propagation
 -  Flame spread
 -  Smoke density
 -  Circuit integrity (FE/PH)
- IEC 60754-1 and IEC 60754-2, EN 50267-2-1, EN 50267-2-2, VDE 0482-267 part 2-1 and part 2-2
IEC 60332-1-2, EN 60332-1-2, VDE 0482-332-1-2
IEC 60332-3-22/-24 Cat. A/C, EN 60332-3-22/-24 Cat. A/C, VDE 0482-332-3-22/-24 Cat. A/C
IEC 61034-1/-2, EN 61034-1/-2, VDE 0482-1034-1/-2
IEC 60331-11/-21 (180minutes), VDE 0472 part 814 (FE180), BS 6387 (cat. CWZ), BS EN 50200 Annex E (30 minutes), BS EN 50200 (PH120), IEC 60331-2 (120 minutes), VDE 0482-200

Standard Fire Safety Cable**Fire alarm cable 300/500V**halogen-free, with improved fire characteristics,
BS 7629-1 and BS 5839-1

PRODUCT INFORMATION

Article No.	Colour	No. of cores x cross section n x mm ²	Cu content kg/km	Total weight approx. kg/km	Outer diameter approx. mm	Fire load kWh/m
187204	red	2 x 1.0	29	78	7.7	0.17
187205	white	2 x 1.0	29	78	7.7	0.17
187209	red	2 x 1.5	43	98	8.3	0.19
187161	white	2 x 1.5	43	98	8.3	0.19
187214	red	2 x 2.5	72	141	9.7	0.26
187162	white	2 x 2.5	72	141	9.7	0.26
187206	red	3 x 1.0	38	95	8.1	0.20
188154	white	3 x 1.0	38	95	8.1	0.20
187210	red	3 x 1.5	58	120	8.7	0.23
187211	white	3 x 1.5	58	120	8.7	0.23
187215	red	3 x 2.5	96	181	10.3	0.31
187216	white	3 x 2.5	96	181	10.3	0.31
187207	red	4 x 1.0	48	119	9.0	0.25
187208	white	4 x 1.0	48	119	9.0	0.25
187212	red	4 x 1.5	72	150	9.7	0.28
187213	white	4 x 1.5	72	150	9.7	0.28
187217	red	4 x 2.5	120	224	11.4	0.39
188155	white	4 x 2.5	120	224	11.4	0.39
188317	red	7 x 1.5	115	230	11.6	0.42

* selected sizes

Additional dimensions available on request.

PREVENTIVE FIRE PROTECTION

Standard Fire Safety Cable

Fire alarm cable 300/500V, flex

halogen-free, with improved fire characteristics,
BS 7629-1 and BS 5839-1

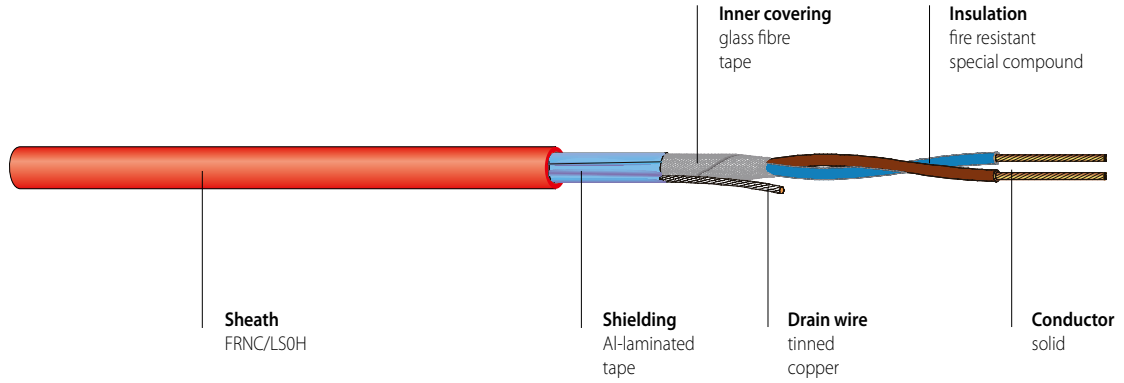

PRODUCT INFORMATION



APPLICATION Cable for fire alarm systems and emergency lighting for permanent installation in buildings. Permitted operating temperature at conductor of +90°C.

CONSTRUCTION	Conductor	Bare copper, solid, IEC 60228 and EN 60228
	Insulation	Special compound, BS EN 50363-5
	Core colours	2 cores + earth: blue, brown 3 cores + earth: brown, black, grey 4 cores + earth: blue, brown, black, grey
	Inner covering	Glass fibre tape
	Shielding	Al-laminated tape and tinned copper drain wire IEC 60228, EN 60228
	Separator	Plastic tape
	Sheath	Polyolefin compound, BS 7655, "LTS3"
	Sheath colour	Red (white or black on request)
ELECTRICAL PROPERTIES	Nominal voltage	300/500V
	Test voltage	2000V, 50Hz
GENERAL PROPERTIES	Minimum bending radius	during and permanent installation 6 x D (D = outer diameter)
	Operating temperature	permanent installation -15°C to +90°C during installation -5°C to +50°C
	Zero halogen, non corrosive gases	IEC 60754-1 and IEC 60754-2, EN 50267-2-1, EN 50267-2-2, VDE 0482-267 part 2-1 and part 2-2
	Flame propagation	IEC 60332-1-2, EN 60332-1-2, VDE 0482-332-1-2
	Flame spread	IEC 60332-3-22/-24 Cat. A/C, EN 60332-3-22/-24 Cat. A/C, VDE 0482-332-3-22/-24 Cat. A/C
	Smoke density	IEC 61034-1/-2, EN 61034-1/-2, VDE 0482-1034-1/-2
	Circuit integrity (FE/PH)	IEC 60331-11/-21 (180minutes), VDE 0472 part 814 (FE180) , BS 6387 (cat. CWZ), BS EN 50200 Annex E (30 minutes), BS EN 50200 (PH120), IEC 60331-2 (120 minutes), VDE 0482-200

Standard Fire Safety Cable

Fire alarm cable 300/500V, flex

halogen-free, with improved fire characteristics,
BS 7629-1 and BS 5839-1

PRODUCT INFORMATION

Article No.	Colour	No. of cores x cross section n x mm ²	Cu content kg/km	Total weight approx. kg/km	Outer diameter approx. mm	Fire load kWh/m
190438	red	2 x 1.0	29	83	8.0	0.20
190427	red	2 x 1.5	43	103	8.9	0.23
190429	red	2 x 2.5	72	152	10.4	0.30
	red	3 x 1.0	38	101	8.5	0.24
190439	red	3 x 1.5	58	130	9.4	0.27
	red	3 x 2.5	96	190	11.0	0.35
192592	red	4 x 1.0	48	127	9.4	0.25
	red	4 x 1.5	72	161	10.4	0.31
190440	red	4 x 2.5	120	235	12.2	0.44

Additional colours/dimensions available on request.

PREVENTIVE FIRE PROTECTION

Enhanced Fire Safety Cable

Fire alarm cable 300/500V

halogen-free, with improved fire characteristics,
BS 7629-1 and BS 5839-1

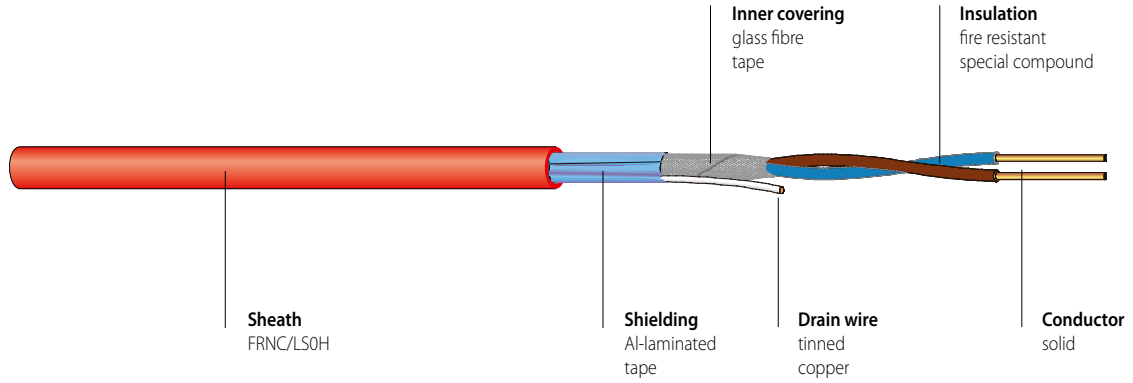

PRODUCT INFORMATION



APPLICATION Cable for fire alarm systems and emergency lighting for permanent installation in buildings. Permitted operating temperature at conductor of +90°C.

CONSTRUCTION

Conductor	Bare copper, solid, IEC 60228 and EN 60228
Insulation	Special compound, BS EN 50363-5
Core colours	2 cores + earth: blue, brown
Inner covering	Glass fibre tape
Shielding	Al-laminated tape and tinned copper drain wire IEC 60228, EN 60228
Separator	Plastic tape
Sheath	Polyolefin compound, BS 7655, "LTS3"
Sheath colour	Red (white or black on request)

ELECTRICAL PROPERTIES

Nominal voltage	300/500V
Test voltage	2000V, 50Hz

GENERAL PROPERTIES

Minimum bending radius	during and permanent installation 6 x D (D = outer diameter)
Operating temperature	permanent installation -15°C to +90°C during installation -5°C to +50°C
Zero halogen, non corrosive gases	IEC 60754-1 and IEC 60754-2, EN 50267-2-1, EN 50267-2-2, VDE 0482-267 part 2-1 and part 2-2
Flame propagation	IEC 60332-1-2, EN 60332-1-2, VDE 0482-332-1-2
Flame spread	IEC 60332-3-22/-24 Cat. A/C, EN 60332-3-22/-24 Cat. A/C, VDE 0482-332-3-22/-24 Cat. A/C
Smoke density	IEC 61034-1/-2, EN 61034-1/-2, VDE 0482-1034-1/-2
Circuit integrity (FE/PH)	IEC 60331-11/-21 (180minutes), VDE 0472 part 814 (FE180) BS 6387 (cat. CWZ) and BS 8434-2 (120 minutes), BS EN 50200 (PH120), IEC 60331-2 (120 minutes), VDE 0482-200

Enhanced Fire Safety Cable**Fire alarm cable 300/500V**halogen-free, with improved fire characteristics,
BS 7629-1 and BS 5839-1

PRODUCT INFORMATION

Article No.	Colour	No. of cores x cross section n x mm ²	Cu content kg/km	Total weight approx. kg/km	Outer diameter approx. mm	Fire load kWh/m
188368	red	2 x 1.5	43	98	8.3	0.19
188369	white	2 x 1.5	43	98	8.3	0.19
188370	red	2 x 2.5	72	141	9.7	0.26
188371	white	2 x 2.5	72	141	9.7	0.26
191679	red	4 x 1.5	72	150	9.7	0.28

* selected sizes

Stranded versions and additional dimensions available on request.

PREVENTIVE FIRE PROTECTION

Armoured Standard Fire Safety Cable

Fire alarm cable with steel wire braiding 300/500V

halogen-free, with improved fire characteristics,
with reference to BS 7629-1

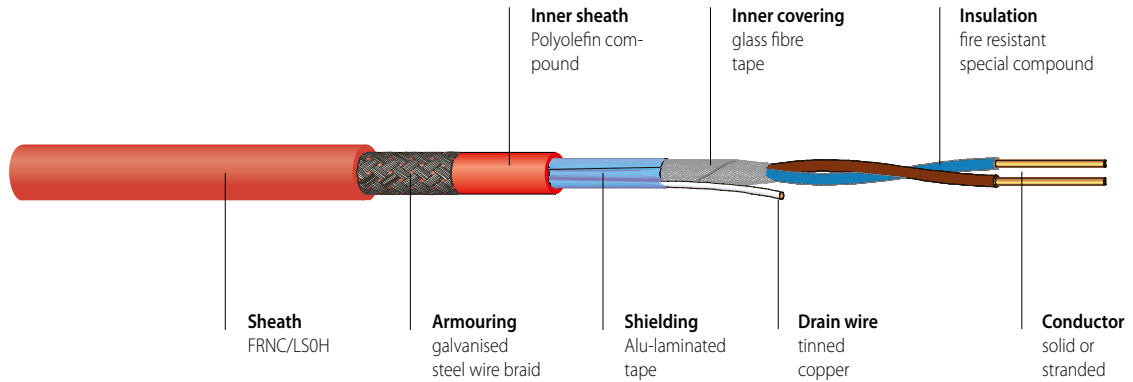

PRODUCT INFORMATION



APPLICATION Armoured cable for fire alarm systems and emergency lighting for permanent installation in buildings. Permitted operating temperature at conductor of +90°C.

CONSTRUCTION





Conductor	Bare copper, solid or stranded in accordance with IEC 60228 and EN 60228
Insulation	Special compound, BS EN 50363-5
Core colours	2 cores + earth: brown, blue 3 cores + earth: brown, black, grey 4 cores + earth: brown, black, grey, blue
Inner covering	Glass fibre tape
Shielding	Al-laminated tape and tinned copper drain wire IEC 60228 class 1 or 2, EN 60228
Inner sheath	Polyolefin compound
Armouring	GSWB, galvanised steel wire braid
Outer sheath	Polyolefin compound, BS 7655 "LTS3"
Sheath colour	Red (white or black on request)

ELECTRICAL PROPERTIES

Nominal voltage	300/500V
Test voltage	2000V, 50Hz

GENERAL PROPERTIES

Minimum bending radius	during and permanent installation	6 x D (D = outer diameter)
Operating temperature	permanent installation	-15°C to +90°C
	during installation	-5°C to +50°C

-  Zero halogen, non corrosive gases IEC 60754-1 and IEC 60754-2, EN 50267-2-1, EN 50267-2-2, VDE 0482-267 part 2-1 and part 2-2
-  Flame propagation IEC 60332-1-2, EN 60332-1-2, VDE 0482-332-1-2
-  Flame spread IEC 60332-3-22/-24 Cat. A/C, EN 60332-3-22/-24 Cat. A/C, VDE 0482-332-3-22/-24 Cat. A/C
-  Smoke density IEC 61034-1/-2, EN 61034-1/-2, VDE 0482-1034-1/-2
-  Circuit integrity (FE/PH) IEC 60331-11/-21 (180minutes), VDE 0472 part 814 (FE180), BS 6387 (cat. CWZ), BS EN 50200 (PH120), IEC 60331-2 (120 minutes), VDE 0482-200

Armoured Standard Fire Safety Cable

Fire alarm cable with steel wire braiding 300/500V

halogen-free, with improved fire characteristics,
with reference to BS 7629-1

PRODUCT INFORMATION

Article No.	Colour	No. of cores x cross section n x mm ²	Cu content kg/km	Total weight approx. kg/km	Outer diameter approx. mm	Fire load kWh/m
184580	red	2 x 1.5	48	190	12.0	0.40
	red	2 x 2.5	72	250	13.0	0.50

Stranded versions and additional colours/dimensions available on request.

PREVENTIVE FIRE PROTECTION

(N)HXH FE180 E30-E60

Safety cable 0.6/1kV, Keram

halogen-free, with improved fire characteristics, with reference to VDE 0266 and CENELEC HD 604 S1, circuit integrity (FE180) in accordance with VDE 0472-814, IEC 60331, System Circuit Integrity E30-E60* in accordance with DIN 4102-12



PRODUCT INFORMATION



APPLICATION

Cables with intrinsic fire resistance are installed in all areas that require special protection of people and equipment against fire and fire damages and where strict security requirements must be fulfilled. Suitable for indoor applications.

For outdoor applications, protection must be provided against exposure to direct sunlight.

The cable should only be laid directly in earth or water if a protective conduit is used.

These cables correspond to the demands of System Circuit Integrity E30-E60* in accordance with DIN 4102-12. System Circuit Integrity is guaranteed at an operating voltage up to 400V.

Permitted operating temperature at conductor of +90°C.

CONSTRUCTION

Conductor	Bare copper, solid or stranded, IEC 60228, EN 60228 (VDE 0295)
Insulation	Double insulation, cross-linked, high-performance Keram special compound, VDE 0266 "HX11"
Filler	Flame retardant, halogen-free thermoplastic compound
Outer sheath	Flame retardant Polyolefin compound, CENELEC HD 604 S1 and VDE 0276-604 "HM4"
Core colours	CENELEC HD 308 S2 and VDE 0293
Sheath colour	Orange

ELECTRICAL PROPERTIES

Rated voltage	0.6/1kV
Test voltage	4000V, 50Hz

GENERAL PROPERTIES

Minimum bending radius	during and permanent installation	15* x D (single core cable) 12* x D (multicore cable) (D = outer diameter)
	permanent installation	*50% reduction if installation at 30°C and with a template
Operating temperature	permanent installation	-45°C to +90°C
	during installation	-5°C to +50°C

Zero halogen, non corrosive gases	IEC 60754-2, EN 50267-2-2, VDE 0482-267-2-2
Flame propagation	IEC 60332-1-2, EN 60332-1-2, VDE 0482-332-1-2
Flame spread	IEC 60332-3-22/-24 Cat. A/C, EN 60332-3-22/-24 Cat. A/C, VDE 0482-332-3-22/24 Cat. A/C
Smoke density	IEC 61034-1/-2, EN 61034-1/-2, VDE 0482-1034-1/-2
Circuit integrity (FE/PH)	IEC 60331-11/-21 (180minutes), VDE 0472 part 814 (FE180), IEC 60331-1, IEC 60331-2 (120 minutes), EN 50200, VDE 0482-200 (PH120) and EN 50362, VDE 0482-362 (120 minutes), BS 6387 C/W/Z
System Circuit Integrity (E30-E60)*	DIN 4102 part 12, NBN 713-020 (Rf1)

* System Circuit Integrity is dependent on installation method.

halogen-free, with improved fire characteristics,
with reference to VDE 0266 and CENELEC HD 604 S1,
circuit integrity (FE180) in accordance with VDE 0472-814, IEC 60331,
System Circuit Integrity E30-E60* in accordance with DIN 4102-12

PRODUCT INFORMATION

Article No.	No. of cores x cross section				Cu content kg/km	Total weight approx. kg/km	Outer diameter approx. mm	Fire load kWh/m
	n	x	mm ²					
171289	1	x	4	RE	38	90	7.1	0.21
171290	1	x	6	RE	58	113	7.6	0.23
171291	1	x	10	RE	96	158	8.4	0.27
171370	1	x	16	RM	154	227	9.8	0.34
171377	1	x	25	RM	240	329	11.3	0.43
171386	1	x	35	RM	336	428	12.4	0.48
171394	1	x	50	RM	480	565	13.9	0.58
171429	1	x	70	RM	672	783	15.7	0.68
170842	1	x	95	RM	912	1054	18.1	0.91
170845	1	x	120	RM	1152	1279	19.2	0.97
170850	1	x	150	RM	1440	1604	21.4	1.20
170855	1	x	185	RM	1776	1981	23.6	1.46
170858	1	x	240	RM	2304	2604	26.8	1.81
186280	2	x	1.5	RE	29	178	11.0	0.48
186921	2	x	2.5	RE	48	217	11.8	0.54
186922	2	x	4	RE	77	272	12.8	0.62
186923	2	x	6	RE	115	337	13.8	0.70
186924	2	x	10	RE	192	459	15.4	0.83
186952	2	x	16	RM	307	661	18.2	1.09
187221	2	x	25	RM	480	950	21.2	1.42
186925	3	x	1.5	RE	43	200	11.5	0.53
186926	3	x	2.5	RE	72	250	12.4	0.60
186927	3	x	4	RE	115	319	13.5	0.68
186928	3	x	6	RE	173	403	14.6	0.77
186929	3	x	10	RE	288	560	16.3	0.91
186953	3	x	16	RM	461	811	19.3	1.19
186955	3	x	25	RM	720	1184	22.6	1.56
186957	3	x	35	RM	1008	1529	24.9	1.80
186959	3	x	50	RM	1440	2026	28.2	2.24
186961	3	x	70	RM	2016	2844	32.7	2.88

RE = circular, solid conductor
RM = circular, stranded conductor

Additional dimensions available on request.

* System Circuit Integrity is dependent on installation method

PREVENTIVE FIRE PROTECTION

(N)HXH FE180 E30-E60

Safety cable 0.6/1kV, Keram

halogen-free, with improved fire characteristics,
with reference to VDE 0266 and CENELEC HD 604 S1,
circuit integrity (FE180) in accordance with VDE 0472-814, IEC 60331,
System Circuit Integrity E30-E60* in accordance with DIN 4102-12

PRODUCT INFORMATION



Article No.	No. of cores x cross section			Cu content kg/km	Total weight approx kg/km	Outer diameter approx. mm	Fire load kWh/m
	n x mm ²						
186954	3	x	25 + 1 x 16 RM	874	1361	23.9	1.73
186956	3	x	35 + 1 x 16 RM	1162	1692	25.9	1.93
186958	3	x	50 + 1 x 25 RM	1680	2311	29.9	2.52
186960	3	x	70 + 1 x 35 RM	2352	3171	34.0	3.07
186962	3	x	95 + 1 x 50 RM	3216	4276	39.3	4.18
186963	3	x	120 + 1 x 70 RM	4128	5303	42.6	4.74
186964	3	x	150 + 1 x 70 RM	4992	6417	46.6	5.63
186965	3	x	185 + 1 x 95 RM	6240	8040	52.0	6.99

186930	4	x	1.5 RE	58	234	12.4	0.61
186931	4	x	2.5 RE	96	296	13.4	0.69
186932	4	x	4 RE	154	381	14.6	0.78
186933	4	x	6 RE	230	490	15.8	0.90
186934	4	x	10 RE	384	695	17.8	1.07
186967	4	x	16 RM	614	1009	21.1	1.40
186968	4	x	25 RM	960	1485	24.8	1.86
186969	4	x	35 RM	1344	1929	27.4	2.15
186970	4	x	50 RM	1920	2600	31.5	2.79
186971	4	x	70 RM	2688	3618	36.2	3.38
186972	4	x	95 RM	3648	4860	41.7	4.68
186973	4	x	120 RM	4608	5890	44.6	5.19
186974	4	x	150 RM	5760	7417	50.0	6.52
187548	4	x	185 RM	7104	9160	55.3	7.98
187077	4	x	240 RM	9216	12043	63.0	10.05

RE = circular, solid conductor
RM = circular, stranded conductor

Additional dimensions available on request.

* System Circuit Integrity is dependent on installation method

halogen-free, with improved fire characteristics,
with reference to VDE 0266 and CENELEC HD 604 S1,
circuit integrity (FE180) in accordance with VDE 0472-814, IEC 60331,
System Circuit Integrity E30-E60* in accordance with DIN 4102-12

PRODUCT INFORMATION

Article No.	No. of cores x cross section			Cu content	Total weight	Outer diameter	Fire load
	n x mm ²						
186935	5	x	1.5 RE	72	278	13.4	0.71
186936	5	x	2.5 RE	120	353	14.5	0.81
186937	5	x	4 RE	192	456	15.8	0.93
186938	5	x	6 RE	288	589	17.2	1.05
186939	5	x	10 RE	480	832	19.3	1.25
186975	5	x	16 RM	768	1223	23.1	1.67
186976	5	x	25 RM	1200	1806	27.2	2.22
186977	5	x	35 RM	1680	2384	30.5	2.66
186978	5	x	50 RM	2400	3187	34.8	3.41
186979	5	x	70 RM	3360	4440	40.0	4.26
190587	5	x	95 RM	4560	6032	46.6	5.89
171272	7	x	1.5 RE	101	331	14.4	0.81
171273	7	x	2.5 RE	168	426	15.6	0.92
171279	12	x	1.5 RE	173	513	18.3	1.20
171280	12	x	2.5 RE	288	675	20.0	1.37
171283	19	x	1.5 RE	274	715	21.2	1.63
171284	19	x	2.5 RE	456	953	23.2	1.83
171285	24	x	1.5 RE	346	901	24.6	1.99
171286	24	x	2.5 RE	576	1205	27.0	2.27
171287	30	x	1.5 RE	432	1057	26.0	2.28
171288	30	x	2.5 RE	720	1446	28.8	2.68

RE = circular, solid conductor
RM = circular, stranded conductor

Additional dimensions available on request.

* System Circuit Integrity is dependent on installation method

PREVENTIVE FIRE PROTECTION

(N)HXCH FE180 E30-E60

Safety cable 0.6/1kV, Keram

halogen-free, with improved fire characteristics, with reference to VDE 0266 and CENELEC HD 604 S1, circuit integrity (FE180) in accordance with VDE 0472-814, IEC 60331, System Circuit Integrity E30-E60* in accordance with DIN 4102-12

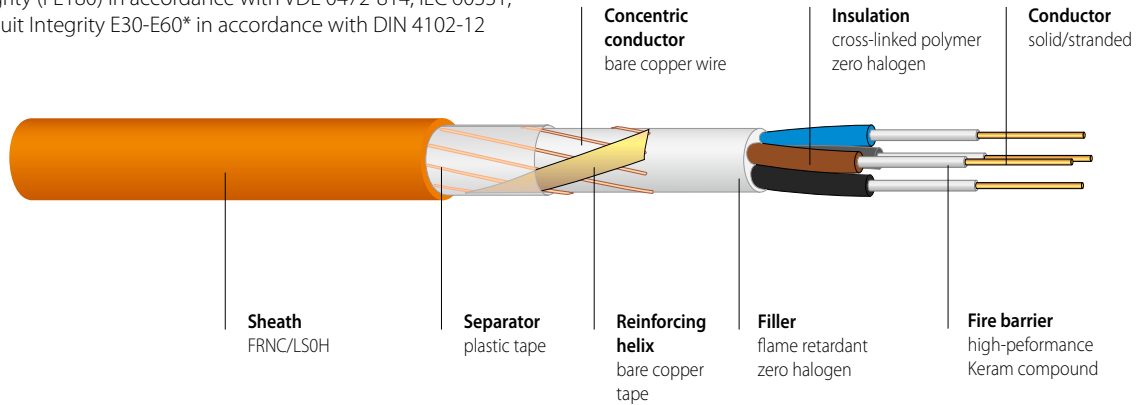

PRODUCT INFORMATION



APPLICATION

Cables with intrinsic fire resistance are installed in all areas that require special protection of people and equipment against fire and fire damages and where strict security requirements must be fulfilled. Suitable for indoor applications.

For outdoor applications, protection must be provided against exposure to direct sunlight.

The cable should only be laid directly in earth or water if a protective conduit is used.

These cables correspond to the demands of System Circuit Integrity E30-E60* in accordance with DIN 4102-12. System Circuit Integrity is guaranteed at an operating voltage up to 400V.

Permitted operating temperature at conductor of +90°C.

CONSTRUCTION

Conductor	Bare copper, solid or stranded, IEC 60228, EN 60228 (VDE 0295)
Insulation	Double insulation, cross-linked, high-performance Keram special compound, VDE 0266 "HX11"
Filler	Flame retardant, halogen-free, thermoplastic compound
Concentric conductor	Bare copper wires with reinforced helix
Separator	Plastic tape
Outer sheath	Polyolefin compound, CENELEC HD 604 S1, VDE 0276-604 "HM4"
Core colours	CENELEC HD 308 S2 and VDE 0293
Sheath colour	Orange

ELECTRICAL PROPERTIES

Nominal voltage	0.6/1kV
Test voltage	4000V, 50Hz

GENERAL PROPERTIES

Minimum bending radius	during and permanent installation	15 x D (single core cable) 12 x D (multicore cable) (D = outer diameter)
Operating temperature	permanent installation during installation	-45°C to +90°C -5°C to +50°C

Zero halogen, non corrosive gases	IEC 60754-2, EN 50267-2-2, VDE 0482-267-2-2
Flame propagation	IEC 60332-1-2, EN 60332-1-2, VDE 0482-332-1-2
Flame spread	IEC 60332-3-22/-24 Cat. A/C, EN 60332-3-22/-24 Cat. A/C, VDE 0482-332-3-22/24 Cat. A/C
Smoke density	IEC 61034-1/-2, EN 61034-1/-2, VDE 0482-1034-1/-2
Circuit integrity (FE/PH)	IEC 60331-11/-21 (180minutes), VDE 0472 part 814 (FE180) IEC 60331-1, IEC 60331-2 (120 minutes), EN 50200, VDE 0482-200 (PH120) and EN 50362, VDE 0482-362 (120 minutes), BS 6387 C/W/Z
System Circuit Integrity (E30-E60)*	DIN 4102 part 12

* System Circuit Integrity is dependent on installation method.

(N)HXCH FE180 E30-E60

Safety cable 0.6/1kV, Keram

halogen-free, with improved fire characteristics,
with reference to VDE 0266 and CENELEC HD 604 S1,
circuit integrity (FE180) in accordance with VDE 0472-814, IEC 60331,
System Circuit Integrity E30-E60* in accordance with DIN 4102-12

PRODUCT INFORMATION

Article No.	No. of cores x cross section			Cu content kg/km	Total weight approx. kg/km	Outer diameter approx. mm	Fire load kWh/m
	n	x	n x mm ²				
186943	2	x	1.5 RE/1.5	52	224	12.7	0.60
186944	2	x	2.5 RE/2.5	80	273	13.5	0.66
187232	2	x	4 RE/4	123	355	15.0	0.78
187234	2	x	6 RE/6	182	436	16.0	0.86
187236	2	x	10 RE/10	312	622	18.0	1.07
186945	3	x	1.5 RE/1.5	66	248	13.2	0.65
186946	3	x	2.5 RE/2.5	104	308	14.1	0.72
187233	3	x	4 RE/4	161	404	15.7	0.84
187235	3	x	6 RE/6	240	504	16.8	0.94
187237	3	x	10 RE/10	408	727	18.9	1.15
187238	3	x	16 RM/16	643	1148	23.9	1.63
187239	3	x	25 RM/16	902	1437	25.0	1.90
187240	3	x	35 RM/16	1190	1796	27.3	2.20
187241	3	x	50 RM/25	1723	2408	30.8	2.84
187242	3	x	70 RM/35	2410	3381	36.0	3.52
186985	3	x	95 RM/50	3296	4513	41.1	4.66
186986	3	x	120 RM/70	4236	5576	44.5	5.30
186987	3	x	150 RM/70	5100	6799	49.2	6.46
187243	3	x	185 RM/95	6383	8300	56.0	7.90
186988	3	x	240 RM/120	8242	11065	61.5	9.93
186947	4	x	1.5 RE/1.5	81	286	14.1	0.73
186948	4	x	2.5 RE/2.5	128	358	15.1	0.82
186949	4	x	4 RE/4	200	473	16.8	0.96
186950	4	x	6 RE/6	297	621	18.1	1.13
186951	4	x	10 RE/10	504	868	20.1	1.33
186989	4	x	16 RM/16	796	1254	23.4	1.70
186990	4	x	25 RM/16	1142	1752	27.2	2.20
186991	4	x	35 RM/16	1526	2210	29.8	2.56
186992	4	x	50 RM/25	2203	3049	34.8	3.41
186993	4	x	70 RM/35	3082	4198	39.5	4.18
186994	4	x	95 RM/50	4208	5600	45.2	5.58
186995	4	x	120 RM/70	5388	6940	49.1	6.37
186996	4	x	150 RM/70	6540	8500	54.3	7.83
186997	4	x	185 RM/95	8159	10615	59.8	9.55
186998	4	x	240 RM/120	10546	13830	67.9	12.00
187244	7	x	1.5 RE/2.5	133	393	16.1	0.94
187245	30	x	1.5 RE/6	499	1252	29.1	2.67

RE = circular, solid conductor, RM = circular, stranded conductor.

Additional dimensions available on request.

* System Circuit Integrity is dependent on installation method

PREVENTIVE FIRE PROTECTION

(N)HXH CL FE180 E30-E60

Safety cable 0.6/1kV armoured with rodent protection, Keram

halogen-free, with improved fire characteristics, with reference to VDE 0266 and CENELEC HD 604 S1, circuit integrity (FE180) in accordance with VDE 0472-814, IEC 60331, System Circuit Integrity E30-E60* in accordance with DIN 4102-12

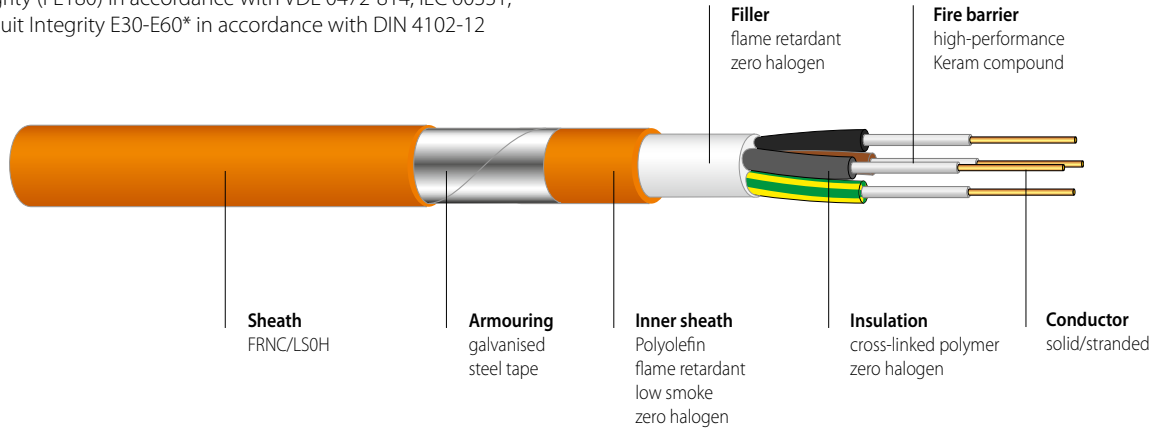

PRODUCT INFORMATION



APPLICATION

Cables with intrinsic fire resistance are installed in all areas that require special protection of people and equipment against fire and fire damages and where strict security requirements must be fulfilled. Suitable for indoor applications.

For outdoor applications, protection must be provided against exposure to direct sunlight.

The cable should only be laid directly in earth or water if a protective conduit is used.

These cables correspond to the demands of Circuit Integrity E30-E60* in accordance with DIN 4102-12.

Circuit Integrity is guaranteed at an operating voltage up to 400V.

Permitted operating temperature at conductor of +90°C.

CONSTRUCTION

Conductor	Bare copper, solid or stranded, IEC 60228, EN 60228, (VDE 0295)
Insulation	Double insulation, cross-linked, high-performance Keram special compound, VDE 0266 "HX11"
Filler	Flame retardant, halogen-free, thermoplastic compound
Inner sheath	Flame retardant Polyolefin compound, CENELEC HD 604 S1 and VDE 0276-604 "HM4"
Armouring (rodent protection)	Single-core cable with copper tape (CLCU) and multicore cable with galvanised steel tape (CL)
Outer sheath	Flame retardant Polyolefin compound, CENELEC HD 604 S1 and VDE 0276-604 "HM4"
Core colours	CENELEC HD 308 S2 and VDE 0293
Sheath colour	Orange

ELECTRICAL PROPERTIES

Nominal voltage	0.6/1kV
Test voltage	4000V, 50Hz

GENERAL PROPERTIES

Minimum bending radius	during and permanent installation	15 x D (single core cable) 12 x D (multicore cable) (D = outer diameter)
Operating temperature	permanent installation	-45°C to +90°C
	during installation	-5°C to +50°C

Zero halogen, non corrosive gases	IEC 60754-2, EN 50267-2-2, VDE 0482-267-2-2
Flame propagation	IEC 60332-1-2, EN 60332-1-2, VDE 0482-332-1-2
Flame spread	IEC 60332-3-22/-24 Cat. A/C, EN 60332-3-22/-24 Cat. A/C, VDE 0482-332-3-22/24 Cat. A/C
Smoke density	IEC 61034-1/-2, EN 61034-1/-2, VDE 0482-1034-1/-2
Circuit integrity (FE/PH)	IEC 60331-11/-21 (180minutes), VDE 0472 part 814 (FE180), BS 6387 C/W/Z
System Circuit Integrity (E30-E60)*	DIN 4102 part 12

* System Circuit Integrity is dependent on installation method.

(N)HXH CL FE180 E30-E60

Safety cable 0.6/1kV armoured with rodent protection, Keram

halogen-free, with improved fire characteristics,
with reference to VDE 0266 and CENELEC HD 604 S1,
circuit integrity (FE180) in accordance with VDE 0472-814, IEC 60331,
System Circuit Integrity E30-E60* in accordance with DIN 4102-12

PRODUCT INFORMATION

Article No.	No. of cores x cross section				Cu content kg/km	Total weight approx. kg/km	Outer diameter approx. mm	Fire load kWh/m
	n x mm ²							
192350	2	x	1.5	RE	29	336	15	0.94
187562	2	x	2.5	RE	48	385	16	1.02
191612	2	x	4	RE	77	453	17	1.13
187563	2	x	6	RE	115	531	18	1.25
	2	x	10	RE	192	673	20	1.43
	2	x	16	RM	307	911	22	1.79
	2	x	25	RM	480	1239	25	2.22
	2	x	35	RM	672	1536	28	2.64
	2	x	50	RM	960	1956	31	3.04
	2	x	70	RM	1344	2640	35	3.79
	2	x	95	RM	1824	3476	40	4.89
	2	x	120	RM	2304	4119	42	5.47
	2	x	150	RM	2880	5087	47	6.62
	2	x	185	RM	3552	6268	52	8.13
191107	3	x	1.5	RE	43	364	16	1.00
186940	3	x	2.5	RE	72	426	17	1.10
192351	3	x	4	RE	115	509	18	1.22
188326	3	x	6	RE	173	607	19	1.35
191597	3	x	10	RE	288	785	21	1.54
188327	3	x	16	RM	461	1075	24	1.93
	3	x	25	RM	720	1491	27	2.41
	3	x	35	RM	1008	1865	29	2.73
	3	x	50	RM	1440	2404	32	3.29
	3	x	70	RM	2016	3315	37	4.22
	3	x	95	RM	2736	4369	42	5.42
	3	x	120	RM	3456	5222	45	6.04
	3	x	150	RM	4320	6460	50	7.30

RE = circular, solid conductor
RM = circular, stranded conductor

Additional dimensions available on request.

* System Circuit Integrity is dependent on installation method

PREVENTIVE FIRE PROTECTION

(N)HXH CL FE180 E30-E60

Safety cable 0.6/1kV armoured with rodent protection, Keram

halogen-free, with improved fire characteristics,

with reference to VDE 0266 and CENELEC HD 604 S1,

circuit integrity (FE180) in accordance with VDE 0472-814, IEC 60331,

System Circuit Integrity E30-E60* in accordance with DIN 4102-12

PRODUCT INFORMATION



Article No.	No. of cores x cross section				Cu content kg/km	Total weight approx. kg/km	Outer diameter approx. mm	Fire load kWh/m
	n x mm ²							
190590	4	x	1.5	RE	58	410	17	1.11
191102	4	x	2.5	RE	96	485	18	1.22
192593	4	x	4	RE	154	585	19	1.36
192594	4	x	6	RE	230	710	20	1.51
186980	4	x	10	RE	384	940	22	1.76
186981	4	x	16	RM	614	1296	25	2.2
186982	4	x	25	RM	960	1820	29	2.78
190589	4	x	35	RM	1344	2296	32	3.16
192428	4	x	50	RM	1920	3037	36	4.02
192429	4	x	70	RM	2688	4157	41	5.05
192430	4	x	95	RM	3648	5498	47	6.52
192430	4	x	120	RM	4608	6595	50	7.26
192347	5	x	1.5	RE	72	466	18	1.25
188117	5	x	2.5	RE	120	556	19	1.38
188118	5	x	4	RE	192	676	20	1.54
186941	5	x	6	RE	288	826	21	1.72
186942	5	x	10	RE	480	1096	24	1.98
190525	5	x	16	RM	768	1460	26	2.53
186984	5	x	25	RM	1200	2171	31	3.23
190529	5	x	35	RM	1680	2730	35	3.85
191565	5	x	50	RM	2400	3620	39	4.83
	5	x	70	RM	3360	5054	45	6.05
	5	x	95	RM	4560	6792	52	8.14
	6	x	1.5	RE	86	521	19	1.39
	6	x	2.5	RE	144	625	20	1.54
188094	6	x	4	RE	230	693	20	1.74
	6	x	6	RE	346	943	23	1.94
	6	x	10	RE	576	1269	25	2.26

RE = circular, solid conductor
RM = circular, stranded conductor

Additional dimensions available on request.

* System Circuit Integrity is dependent on installation method

(N)HXH CL FE180 E30-E60

Safety cable 0.6/1kV armoured with rodent protection, Keram

halogen-free, with improved fire characteristics,
with reference to VDE 0266 and CENELEC HD 604 S1,
circuit integrity (FE180) in accordance with VDE 0472-814, IEC 60331,
System Circuit Integrity E30-E60* in accordance with DIN 4102-12

PRODUCT INFORMATION

Article No.	No. of cores x cross section				Cu content kg/km	Total weight approx. kg/km	Outer diameter approx. mm	Fire load kWh/m
	n x mm ²							
185232	7	x	1.5	RE	101	532	19	1.38
	7	x	2.5	RE	168	643	20	1.53
185245	7	x	4	RE	269	799	21	1.71
185247	7	x	6	RE	403	987	23	1.9
185248	7	x	10	RE	672	1343	25	2.2
	8	x	1.5	RE	115	605	20	1.53
	8	x	2.5	RE	192	732	21	1.69
188095	8	x	4	RE	307	916	23	1.91
	10	x	1.5	RE	144	701	22	1.78
	10	x	2.5	RE	240	858	24	1.98
	10	x	4	RE	384	1080	26	2.24
	12	x	1.5	RE	173	764	23	1.9
185239	12	x	2.5	RE	288	873	23	2.13
	12	x	4	RE	461	1205	26	2.42
	14	x	1.5	RE	202	847	23	2.07
	14	x	2.5	RE	336	1062	25	2.34
185233	16	x	1.5	RE	231	926	24	2.24
192725	16	x	2.5	RE	384	1155	26	2.52
	21	x	1.5	RE	303	1093	27	2.58
	21	x	2.5	RE	504	1381	29	2.89
	27	x	1.5	RE	389	1311	29	3.06
	27	x	2.5	RE	648	1681	32	3.45
185235	30	x	1.5	RE	432	1407	30	3.25
185241	30	x	2.5	RE	720	1848	33	3.81

RE = circular, solid conductor, RM = circular, stranded conductor

Additional dimensions available on request.

*System Circuit Integrity is dependent on installation method

PREVENTIVE FIRE PROTECTION

(N)HXH FE180 E90

Safety cable 0.6/1kV, Keram

halogen-free, with improved fire characteristics, with reference to VDE 0266 and CENELEC HD 604 S1, circuit integrity (FE180) in accordance with VDE 0472-814, IEC 60331, System Circuit Integrity E90* in accordance with DIN 4102-12



PRODUCT INFORMATION



APPLICATION

Cables with intrinsic fire resistance are installed in all areas that require special protection of people and equipment against fire and fire damages and where strict security requirements must be fulfilled. Suitable for indoor applications.

For outdoor applications, protection must be provided against exposure to direct sunlight.

The cable should only be laid directly in earth or water if a protective conduit is used.

These cables correspond to the demands of System Circuit Integrity E90* in accordance with DIN 4102-12. System Circuit Integrity is guaranteed at an operating voltage up to 400V.

Permitted operating temperature at conductor of +90°C.

CONSTRUCTION

Conductor	Bare copper, solid or stranded, IEC 60228, EN 60228 (VDE 0295)
Insulation	Double insulation, cross-linked, high-performance Keram special compound, VDE 0266 "HX11"
Filler	Flame retardant, halogen-free, thermoplastic compound
Outer sheath	Flame retardant Polyolefin compound, CENELEC HD 604 S1 and VDE 0276-604 "HM4"
Core colours	CENELEC HD 308 S2 and VDE 0293
Sheath colour	Orange

ELECTRICAL PROPERTIES

Nominal voltage	0.6/1kV
Test voltage	4000V, 50Hz

GENERAL PROPERTIES

Minimum bending radius	during and permanent installation	15* x D (single-core cable) 12* x D (multicore cable) (D = outer diameter)
	permanent installation	*50% reduction if installation at 30°C and with a template
Operating temperature	permanent installation	-45°C to +90°C
	during installation	-5°C to +50°C

Zero halogen, non corrosive gases	IEC 60754-2, EN 50267-2-2, VDE 0482-267-2-2
Flame propagation	IEC 60332-1-2, EN 60332-1-2, VDE 0482-332-1-2
Flame spread	IEC 60332-3-22/-24 Cat. A/C, EN 60332-3-22/-24 Cat. A/C, VDE 0482-332-3-22/24 Cat. A/C
Smoke density	IEC 61034-1/-2, EN 61034-1/-2, VDE 0482-1034-1/-2
Circuit integrity (FE/PH)	IEC 60331-11/-21 (180minutes), VDE 0472 part 814 (FE180) IEC 60331-1, IEC 60331-2 (120 minutes), EN 50200, VDE 0482-200 (PH120) and EN 50362, VDE 0482-362 (120 minutes), BS 6387 C/W/Z
System Circuit Integrity (E90)*	DIN 4102 part 12
System Circuit Integrity under effect of water	VdS 3423 (single core cable ≥16mm ²)

* System Circuit Integrity is dependent on installation method.

(N)HXH FE180 E90

Safety cable 0.6/1kV, Keram

halogen-free, with improved fire characteristics,
with reference to VDE 0266 and CENELEC HD 604 S1,
circuit integrity (FE180) in accordance with VDE 0472-814, IEC 60331,
System Circuit Integrity E90* in accordance with DIN 4102-12

PRODUCT INFORMATION

Article No.	No. of cores x cross section			Cu content kg/km	Total weight approx. kg/km	Outer diameter approx. mm	Fire load kWh/m
	n x mm ²						
186141	1	x	16 RM	154	243	10.2	0.35
186142	1	x	25 RM	240	347	11.7	0.43
186143	1	x	35 RM	336	449	12.8	0.49
186144	1	x	50 RM	480	589	14.3	0.58
186145	1	x	70 RM	672	810	16.1	0.67
186146	1	x	95 RM	912	1090	18.5	0.85
186147	1	x	120 RM	1152	1318	19.6	0.91
186148	1	x	150 RM	1440	1648	21.8	1.11
186149	1	x	185 RM	1776	2029	24.0	1.32
186150	1	x	240 RM	2304	2658	27.2	1.63
186151	1	x	300 RM	2880	3166	29.6	1.91
188359	2	x	1.5 RE	29	178	11.0	0.48
187247	2	x	2.5 RE	48	217	11.8	0.54
187248	2	x	4 RE	77	272	12.8	0.62
187249	2	x	6 RE	115	337	13.8	0.70
187250	2	x	10 RE	192	459	15.4	0.83
187254	2	x	16 RM	307	714	19.0	1.19
187255	2	x	25 RM	480	1011	22.0	1.54
187256	2	x	35 RM	672	1287	24.2	1.79
187257	2	x	50 RM	960	1742	28.0	2.35
187258	2	x	70 RM	1344	2346	31.6	2.86
187259	2	x	95 RM	1824	3130	36.2	3.67
187260	2	x	120 RM	2304	3729	38.6	4.11
186174	3	x	1.5 RE	43	200	11.5	0.53
186177	3	x	2.5 RE	72	250	12.4	0.60
186182	3	x	4 RE	115	319	13.5	0.68
186186	3	x	6 RE	173	403	14.6	0.77
186189	3	x	10 RE	288	560	16.3	0.91
186152	3	x	16 RM	461	878	20.2	1.29
186153	3	x	25 RM	720	1299	24.0	1.75
186154	3	x	35 RM	1008	1664	26.4	2.02
186207	3	x	50 RM	1440	2189	29.8	2.51
187261	3	x	70 RM	2016	2997	33.9	3.09
187262	3	x	95 RM	2736	4007	38.9	3.95
187263	3	x	120 RM	3456	4812	41.5	4.39
187264	3	x	150 RM	4320	5988	46.0	5.32
187265	3	x	185 RM	5328	7363	50.7	6.44
187266	3	x	240 RM	6912	9632	57.6	8.10

RE = circular, solid conductor, RM = circular, stranded conductor

Additional dimensions available on request.

* System Circuit Integrity is dependent on installation method.

PREVENTIVE FIRE PROTECTION

(N)HXH FE180 E90

Safety cable 0.6/1kV, Keram

halogen-free, with improved fire characteristics,
with reference to VDE 0266 and CENELEC HD 604 S1,
circuit integrity (FE180) in accordance with VDE 0472-814, IEC 60331,
System Circuit Integrity E90* in accordance with DIN 4102-12

PRODUCT INFORMATION

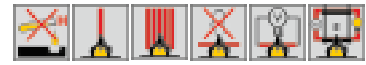

Article No.	No. of cores x cross section		Cu content	Total weight	Outer diameter	Fire load
	n x mm ²					
191069	3 x	35 + 1 x 16 RM	1162	1833	27.4	2.13
191002	3 x	50 + 1 x 25 RM	1680	2457	31.3	2.69
191003	3 x	70 + 1 x 35 RM	2352	3362	35.6	3.34
191004	3 x	95 + 1 x 50 RM	3216	4488	40.7	4.24
191005	3 x	120 + 1 x 70 RM	4128	5532	44.0	4.82
191006	3 x	150 + 1 x 70 RM	4992	6666	48.0	5.70
191068	3 x	185 + 1 x 95 RM	6240	8315	53.4	7.00
186175	4 x	1.5 RE	58	234	12.4	0.61
186178	4 x	2.5 RE	96	296	13.4	0.69
186183	4 x	4 RE	154	381	14.6	0.78
186187	4 x	6 RE	230	490	15.8	0.90
186190	4 x	10 RE	384	695	17.8	1.07
186155	4 x	16 RM	614	1089	22.1	1.54
186156	4 x	25 RM	960	1618	26.3	2.05
186157	4 x	35 RM	1344	2083	29.0	2.36
186158	4 x	50 RM	1920	2752	32.8	2.97
186159	4 x	70 RM	2688	3804	37.6	3.55
186160	4 x	95 RM	3648	5092	43.1	4.75
187274	4 x	120 RM	4608	6133	46.0	5.27
186161	4 x	150 RM	5760	7662	51.2	6.49
187275	4 x	185 RM	7104	9425	56.5	7.85
190493	4 x	240 RM	9216	12334	64.1	9.85

RE = circular, solid conductor
RM = circular, stranded conductor

Additional dimensions available on request.

* System Circuit Integrity is dependent on installation method.

halogen-free, with improved fire characteristics,
with reference to VDE 0266 and CENELEC HD 604 S1,
circuit integrity (FE180) in accordance with VDE 0472-814, IEC 60331,
System Circuit Integrity E90* in accordance with DIN 4102-12

PRODUCT INFORMATION

Article No.	No. of cores x cross section				Cu content kg/km	Total weight approx. kg/km	Outer diameter approx. mm	Fire load kWh/m
	n x mm ²							
186176	5	x	1.5	RE	72	278	13.4	0.71
186179	5	x	2.5	RE	120	353	14.5	0.81
186184	5	x	4	RE	192	456	15.8	0.93
186188	5	x	6	RE	288	589	17.2	1.05
186191	5	x	10	RE	480	832	19.3	1.25
186162	5	x	16	RM	768	1361	24.8	1.86
186163	5	x	25	RM	1200	1960	28.8	2.42
186164	5	x	35	RM	1680	2547	32.0	2.86
186165	5	x	50	RM	2400	3392	36.5	3.68
187277	5	x	70	RM	3360	4667	41.5	4.51
185271	7	x	1.5	RE	101	331	14.4	0.81
186180	7	x	2.5	RE	168	426	15.6	0.92
186185	7	x	4	RE	269	563	17.1	1.05
172260	10	x	1.5	RE	144	457	17.8	1.09
187253	10	x	2.5	RE	240	593	19.4	1.24
185272	12	x	1.5	RE	173	513	18.3	1.20
186181	12	x	2.5	RE	288	675	20.0	1.37
185273	24	x	1.5	RE	346	901	24.6	1.99

RE = circular, solid conductor
RM = circular, stranded conductor

Additional dimensions available on request.

* System Circuit Integrity is dependent on installation method.

PREVENTIVE FIRE PROTECTION

(N)HXCH FE180 E90

Safety cable 0.6/1kV, Keram

halogen-free, with improved fire characteristics, with reference to VDE 0266 and CENELEC HD 604 S1, circuit integrity (FE180) in accordance with VDE 0472-814, IEC 60331, System Circuit Integrity E90 in accordance with DIN 4102-12

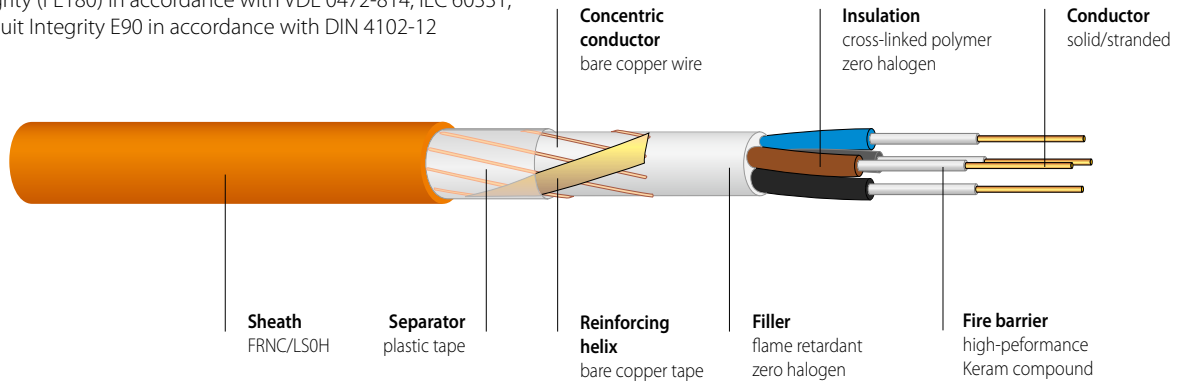

PRODUCT INFORMATION



APPLICATION

Cables with intrinsic fire resistance are installed in all areas that require special protection of people and equipment against fire and fire damages and where strict security requirements must be fulfilled. Suitable for indoor applications.

For outdoor applications, protection must be provided against exposure to direct sunlight.

The cable should only be laid directly in earth or water if a protective conduit is used.

These cables correspond to the demands of System Circuit Integrity E90* in accordance with DIN 4102-12. System Circuit Integrity is guaranteed at an operating voltage up to 400V.

Permitted operating temperature at conductor of +90°C.

CONSTRUCTION

Conductor	Bare copper, solid or stranded, IEC 60228, EN 60228 (VDE 0295)
Insulation	Double insulation, cross-linked, high-performance Keram special compound, VDE 0266 "HX11"
Filler	Halogen-free compound or plastic tape
Concentric conductor	Bare copper wires with reinforced helix
Separator	Plastic tape
Outer sheath	Polyolefin compound, CENELEC HD 604 S1, VDE 0276-604 "HM4"
Core colours	CENELEC HD 308 S2 and VDE 0293
Sheath colour	Orange

ELECTRICAL PROPERTIES

Nominal voltage	0.6/1kV
Test voltage	4000V, 50Hz

GENERAL PROPERTIES

Minimum bending radius	during and permanent installation	12 x D (multicore cable) (D = outer diameter)
Operating temperature	permanent installation	-45°C to +90°C
	during installation	-5°C to +50°C

Zero halogen, non corrosive gases	IEC 60754-2, EN 50267-2-2, VDE 0482-267-2-2
Flame propagation	IEC 60332-1-2, EN 60332-1-2, VDE 0482-332-1-2
Flame spread	IEC 60332-3-22/-24 Cat. A/C, EN 60332-3-22/-24 Cat. A/C, VDE 0482-332-3-22/24 Cat. A/C
Smoke density	IEC 61034-1/-2, EN 61034-1/-2, VDE 0482-1034-1/-2
Circuit integrity (FE/PH)	IEC 60331-11/-21 (180minutes), VDE 0472 part 814 (FE180) IEC 60331-1, IEC 60331-2 (120 minutes), EN 50200, VDE 0482-200 (PH120) and EN 50362, VDE 0482-362 (120 minutes), BS 6387 C/W/Z
System Circuit Integrity (E90)*	DIN 4102 part 12
System Circuit Integrity under effect of water	VdS 3423 (n x ≥ 16mm²)

* System Circuit Integrity is dependent on installation method.

(N)HXCH FE180 E90

Safety cable 0.6/1kV, Keram

halogen-free, with improved fire characteristics,
with reference to VDE 0266 and CENELEC HD 604 S1,
circuit integrity (FE180) in accordance with VDE 0472-814, IEC 60331,
System Circuit Integrity E90* in accordance with DIN 4102-12

PRODUCT INFORMATION

Article No.	No. of cores x cross section			Cu content kg/km	Total weight approx. kg/km	Outer diameter approx. mm	Fire load kWh/m
	n	x	n x mm ²				
186071	3	x	1.5 RE/1.5	66	248	13.2	0.65
186195	3	x	2.5 RE/2.5	104	308	14.1	0.72
186197	3	x	4 RE/4	161	404	15.7	0.84
187278	3	x	6 RE/6	240	504	16.8	0.94
187279	3	x	10 RE/10	408	727	18.6	1.15
187251	3	x	16 RM/16	643	1166	24.4	1.64
187406	3	x	25 RM/16	902	1496	25.8	1.95
172417	3	x	35 RM/16	1190	1820	28.2	2.25
187408	3	x	50 RM/25	1723	2493	32.5	2.90
187409	3	x	70 RM/35	2410	3350	36.1	3.42
187410	3	x	95 RM/50	3296	4570	42.0	4.50
187411	3	x	120 RM/70	4236	5620	45.4	5.02
187412	3	x	150 RM/70	5100	6850	50.7	6.00
187413	3	x	185 RM/95	6383	8350	55.0	7.10
187414	3	x	240 RM/120	8242	11100	62.1	9.08
186072	4	x	1.5 RE/1.5	81	286	14.1	0.73
186196	4	x	2.5 RE/2.5	128	358	15.1	0.82
186198	4	x	4 RE/4	200	473	16.8	0.96
186199	4	x	6 RE/6	297	621	18.1	1.13
186200	4	x	10 RE/10	504	868	20.1	1.33
186131	4	x	16 RM/16	796	1400	25.3	1.81
186132	4	x	25 RM/16	1142	1895	28.9	2.28
186133	4	x	35 RM/16	1526	2376	31.6	2.60
186134	4	x	50 RM/25	2203	3249	36.7	3.49
186135	4	x	70 RM/35	3082	4426	41.3	4.25
186136	4	x	95 RM/50	4208	5809	46.4	5.53
186137	4	x	120 RM/70	5388	7134	50.1	6.25
186138	4	x	150 RM/70	6540	8703	55.3	7.58
186139	4	x	185 RM/95	8159	10827	60.8	9.18
186140	4	x	240 RM/120	10546	14139	69.2	11.60
186073	7	x	1.5 RE/2.5	133	393	16.1	0.94
191096	7	x	2.5 RE/2.5	200	491	17.3	1.05
187415	12	x	1.5 RE/2.5	205	595	20.2	1.38
172461	12	x	2.5 RE/4	334	798	22.6	1.63
187402	24	x	1.5 RE/6	413	901	27.4	2.32
187403	24	x	2.5 RE/10	696	1205	30.6	2.69
187404	30	x	1.5 RE/6	499	1252	29.1	2.67
187405	30	x	2.5 RE/10	840	1692	32.2	3.11

Additional dimensions available on request.

* System Circuit Integrity is dependent on installation method.

PREVENTIVE FIRE PROTECTION

JE-H(St)H...Bd FE180 E30 L

Wiring cable for industrial electronics max. 225V, Keram

halogen-free, with improved fire characteristics,
with reference to VDE 0815,
circuit integrity (FE180) in accordance with VDE 0472-814, IEC 60331, EN 50200,
System Circuit Integrity E30 in accordance with DIN 4102-12

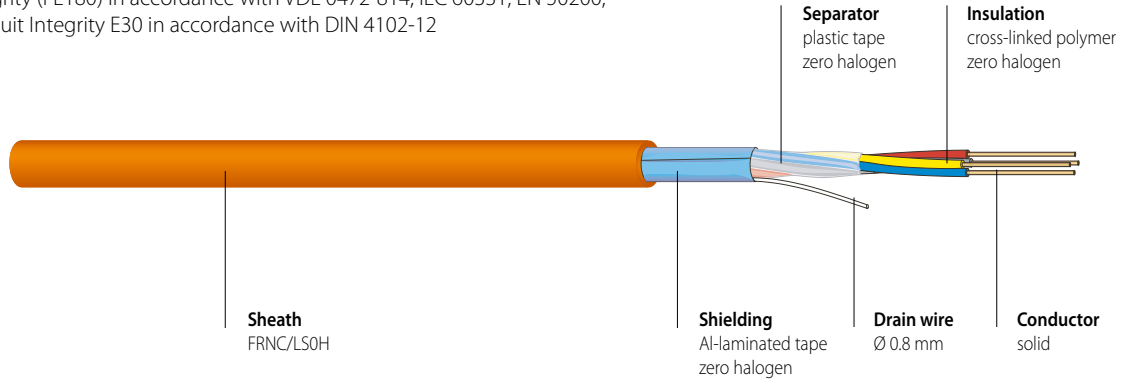

PRODUCT INFORMATION



APPLICATION

Cables with intrinsic fire resistance are installed in all areas that require special protection of people and equipment against fire and fire damages and where strict security requirements must be fulfilled. Suitable for indoor applications.

For outdoor applications, protection must be provided against exposure to direct sunlight.

The cable should only be laid directly in earth or water if a protective conduit is used.

These cables correspond to the demands of System Circuit Integrity E30* in accordance with DIN 4102-12. System Circuit Integrity is guaranteed at an operating voltage up to 110V.

Permitted operating temperature at conductor of +70°C.

CONSTRUCTION

Conductor	Bare copper, solid, 0.8 mm diameter, VDE 0815
Insulation	Fire-resistant, cross-linked, high-performance Keram special compound, EN 50290-2-26
Core colours	VDE 0815, bundles identified by numbered tape
Separator	PEPT "Plastic Tape"
Shielding	Al-laminated tape with tinned copper drain wire Ø 0.8 mm
Outer sheath	Flame retardant polyolefin compound VDE 0819 part 107, EN 50290-2-27 and VDE 0250-214 "HM 2"
Sheath colour	Orange

ELECTRICAL PROPERTIES

Insulation resistance	minimum 100 MΩ x km
Loop resistance	maximum 73.2 Ω/km at 0.80 mm
Capacitance unbalance	maximum 120 nF/km at 800 Hz
Capacitance coupling	K maximum 200 pF/100m at 800 Hz
Rated voltage	maximum 225 V
Test voltage	500 V, 50 Hz Core/Core 2000 V, 50Hz, Core/Screen

GENERAL PROPERTIES

Minimum bending radius	during installation	7.5 x D (D = outer diameter)
	permanent installation	2.5 x D
Crush resistance	≥ 1000 N/10 cm	
Impact	≥ 10 impacts	
Operating temperature	permanent installation	-30°C to +70°C
	during installation	-5°C to +50°C

Zero halogen,	
non corrosive gases	IEC 60754-2, EN 50267-2-2, VDE 0482-267-2-2
Flame propagation	IEC 60332-1-2, EN 60332-1-2, VDE 0482-332-1-2
Flame spread	IEC 60332-3-22/-24 Cat. A/C, EN 60332-3-22/-24 Cat. A/C, VDE 0482-332-3-22/24 Cat. A/C
Smoke density	IEC 61034-1/-2, EN 61034-1/-2, VDE 0482-1034-1/-2
Circuit integrity (FE/PH)	IEC 60331-11/-21 (180minutes), VDE 0472 part 814 (FE180) IEC 60331-2, EN 50200, VDE 0482-200
System Circuit Integrity (E30)*	DIN 4102 part 12, NBN 713-020

* System Circuit Integrity is dependent on installation method.

JE-H(St)H...Bd FE180 E30 L

Wiring cable for industrial electronics max. 225V, Keram

halogen-free, with improved fire characteristics,
with reference to VDE 0815,

circuit integrity (FE180) in accordance with VDE 0472-814, IEC 60331, EN 50200,
System Circuit Integrity E30* in accordance with DIN 4102-12

PRODUCT INFORMATION

Article No.	No. of cores x conductor diameter				Cu content kg/km	Total weight approx. kg/km	Outer diameter approx. mm	Fire load kWh/m
	n x mm							
188376	1	x	2	x 0.80	15	40	5.5	0.095
188318	2	x	2	x 0.80	25	56	6.0	0.123
188325	4	x	2	x 0.80	45	96	8.7	0.21

Additional dimensions available on request.

* System Circuit Integrity is dependent on installation method.

PREVENTIVE FIRE PROTECTION

JE-H(St)H...Bd FE180 E30-E90

Wiring cable for industrial electronics max. 225V, Keram

halogen-free, with improved fire characteristics,
with reference to VDE 0815,
circuit integrity (FE180) in accordance with VDE 0472-814, IEC 60331, EN 50200,
System Circuit Integrity E30-E90* in accordance with DIN 4102-12

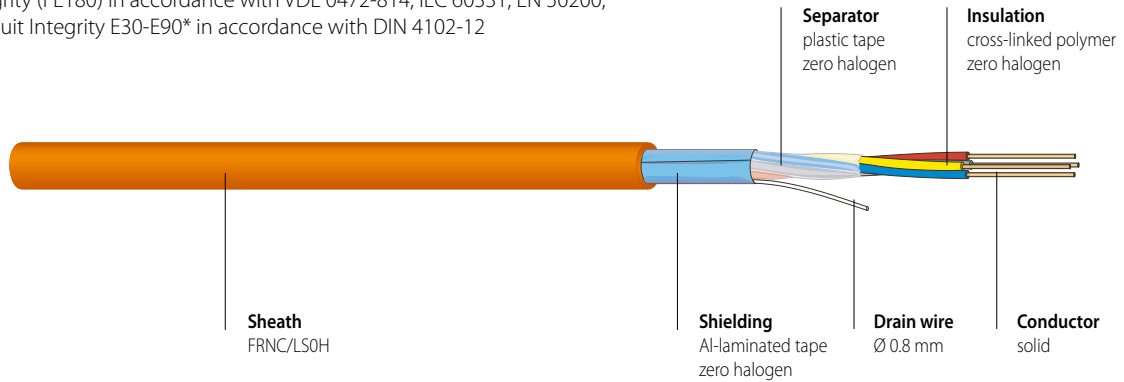

PRODUCT INFORMATION



APPLICATION

Cables with intrinsic fire resistance are installed in all areas that require special protection of people and equipment against fire and fire damages and where strict security requirements must be fulfilled. Suitable for indoor applications.

For outdoor applications, protection must be provided against exposure to direct sunlight.

The cable should only be laid directly in earth or water if a protective conduit is used.

These cables correspond to the demands of System Circuit Integrity E30-E90* in accordance with DIN 4102-12. System Circuit Integrity is guaranteed at an operating voltage up to 110V.

Permitted operating temperature at conductor of +70°C.

CONSTRUCTION

Conductor	Bare copper, solid, 0.8 mm diameter, VDE 0815
Insulation	Fire-resistant, cross-linked, high-performance Keram special compound, EN 50290-2-26
Core colours	VDE 0815, bundles identified by numbered tape
Separator	PEPT "Plastic Tape"
Shielding	Al-laminated tape with tinned copper drain wire Ø 0.8 mm
Outer sheath	Flame retardant polyolefin compound, VDE 0819 part 107, EN 50290-2-27 and VDE 0250-214 "HM 2"
Sheath colour	Orange

ELECTRICAL PROPERTIES

Insulation resistance	minimum 100 MΩ x km
Loop resistance	maximum 73.2 Ω/km at 0.80 mm
Capacitance unbalance	maximum 120 nF/km at 800 Hz
Capacitance coupling	K maximum 200 pF/100m at 800 Hz
Rated voltage	maximum 225 V
Test voltage	500 V, 50 Hz Core/Core 2000 V, 50Hz, Core/Screen

GENERAL PROPERTIES

Minimum bending radius	during installation	7.5 x D (D = outer diameter)
	permanent installation	2.5 x D
Crush resistance	≥ 1000 N/10 cm	
Impact	≥ 10 impacts	
Operating temperature	permanent installation	-30°C to +70°C
	during installation	-5°C to +50°C

Zero halogen, non corrosive gases	IEC 60754-2, EN 50267-2-2, VDE 0482-267-2-2
Flame propagation	IEC 60332-1-2, EN 60332-1-2, VDE 0482-332-1-2
Flame spread	IEC 60332-3-22/-24 Cat. A/C, EN 60332-3-22/-24 Cat. A/C, VDE 0482-332-3-22/24 Cat. A/C
Smoke density	IEC 61034-1/-2, EN 61034-1/-2, VDE 0482-1034-1/-2
Circuit integrity (FE/PH)	IEC 60331-11/-21 (180minutes), VDE 0472 part 814 (FE180), IEC 60331-2, EN 50200, VDE 0482-200
System Circuit Integrity (E30-E90)*	DIN 4102 part 12, NBN 713-020 (Rf 1½)

* System Circuit Integrity is dependent on installation method.

JE-H(St)H...Bd FE180 E30-E90

Wiring cable for industrial electronics max. 225V, Keram

halogen-free, with improved fire characteristics,
with reference to VDE 0815,

circuit integrity (FE180) in accordance with VDE 0472-814, IEC 60331, EN 50200,
System Circuit Integrity E30-E90* in accordance with DIN 4102-12

PRODUCT INFORMATION

Article No.	No. of cores x conductor diameter				Cu content kg/km	Total weight approx. kg/km	Outer diameter approx. mm	Fire load kWh/m
	n x mm							
188092	1	x	2	x 0.80	15	40	5.5	0.095
188097	2	x	2	x 0.80	25	56	6.0	0.123
188099	4	x	2	x 0.80	45	96	8.7	0.21
188102	8	x	2	x 0.80	85	218	13.7	0.52
188104	12	x	2	x 0.80	126	270	14.6	0.58
188106	16	x	2	x 0.80	166	337	16.0	0.69
188108	20	x	2	x 0.80	206	403	18.0	0.80
188111	32	x	2	x 0.80	326	570	21.8	1.02
188113	40	x	2	x 0.80	407	739	25.3	1.38
188115	52	x	2	x 0.80	529	906	27.6	1.59

Additional dimensions available on request.

* System Circuit Integrity is dependent on installation method.

PREVENTIVE FIRE PROTECTION

JE-H(St)H...Bd FE180 E30 L

Fire alarm cable max. 225V, Keram

halogen-free, with improved fire characteristics,
with reference to VDE 0815,
circuit integrity (FE180) in accordance with VDE 0472-814, IEC 60331, EN 50200,
System Circuit Integrity E30* in accordance with DIN 4102-12

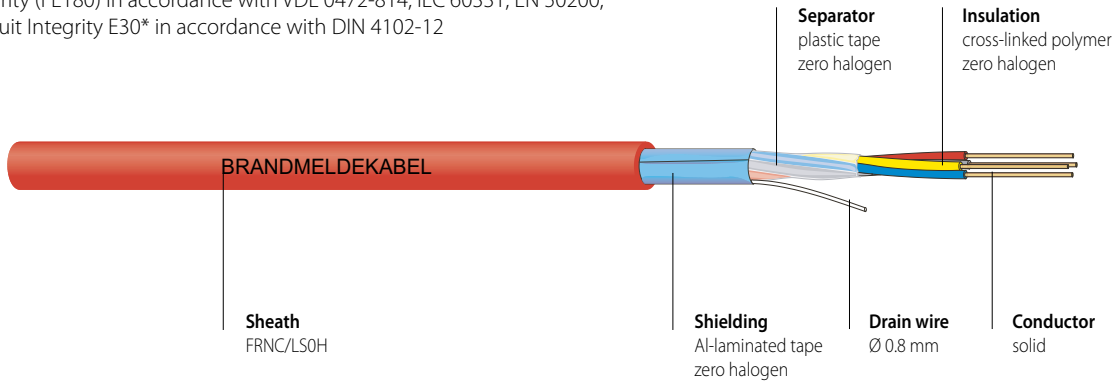

PRODUCT INFORMATION



APPLICATION

Cables with intrinsic fire resistance are installed in all areas that require special protection of people and equipment against fire and fire damages and where strict security requirements must be fulfilled. Suitable for indoor applications.

For outdoor applications, protection must be provided against exposure to direct sunlight.

The cable should only be laid directly in earth or water if a protective conduit is used.

These cables correspond to the demands of System Circuit Integrity E30* in accordance with DIN 4102-12. System Circuit Integrity is guaranteed at an operating voltage up to 110V.

Permitted operating temperature at conductor of +70°C.







CONSTRUCTION

Conductor	Bare copper, solid, 0.8 mm diameter, VDE 0815
Insulation	Fire-resistant, cross-linked, high-performance Keram special compound, EN 50290-2-26
Core colours	VDE 0815, bundles identified by numbered tape
Separator	PEPT "Plastic Tape"
Shielding	Al-laminated tape with tinned copper drain wire Ø 0.8 mm
Outer sheath	Flame retardant polyolefin compound, VDE 0819 part 107, EN 50290-2-27 and VDE 0250-214 "HM 2"
Sheath colour	Red

ELECTRICAL PROPERTIES

Insulation resistance	minimum 100 MΩ x km
Loop resistance	maximum 73.2 Ω/km at 0.80 mm
Capacitance unbalance	maximum 120 nF/km at 800 Hz
Capacitance coupling	K maximum 200 pF/100m at 800 Hz
Rated voltage	maximum 225 V
Test voltage	500 V, 50 Hz Core/Core 2000 V, 50Hz, Core/Screen

GENERAL PROPERTIES

Minimum bending radius	during installation	7.5 x D (D = outer diameter)
	permanent installation	2.5 x D
Crush resistance	≥ 1000 N/10 cm	
Impact	≥ 10 Impacts	
Operating temperature	permanent installation	-30°C to +70°C
	during installation	-5°C to +50°C
 Zero halogen,		
 non corrosive gases		IEC 60754-2, EN 50267-2-2, VDE 0482-267-2-2
 Flame propagation		IEC 60332-1-2, EN 60332-1-2, VDE 0482-332-1-2
 Flame spread		IEC 60332-3-22/-24 Cat. A/C, EN 60332-3-22/-24 Cat. A/C, VDE 0482-332-3-22/24 Cat. A/C
 Smoke density		IEC 61034-1/-2, EN 61034-1/-2, VDE 0482-1034-1/-2
 Circuit integrity (FE/PH)		IEC 60331-11/-21 (180minutes), VDE 0472 part 814 (FE180), IEC 60331-2, EN 50200, VDE 0482-200
 System Circuit Integrity (E30)*		DIN 4102 part 12, NBN 713-020

* System Circuit Integrity is dependent on installation method.

PRODUCT INFORMATION

Article No.	No. of cores x conductor diameter				Cu content kg/km	Total weight approx. kg/km	Outer diameter approx. mm	Fire load kWh/m
	n x mm							
188377	1	x	2	x 0.80	15	40	5.5	0.095
188374	2	x	2	x 0.80	25	56	6.0	0.123
188375	4	x	2	x 0.80	45	96	8.7	0.21

Additional dimensions available on request.

* System Circuit Integrity is dependent on installation method.

PREVENTIVE FIRE PROTECTION

JE-H(St)H...Bd FE180 E30-E90

Fire alarm cable max. 225V, Keram

halogen-free, with improved fire characteristics, with reference to VDE 0815, circuit integrity (FE180) in accordance with VDE 0472-814, IEC 60331, EN 50200, System Circuit Integrity E30-E90* in accordance with DIN 4102-12

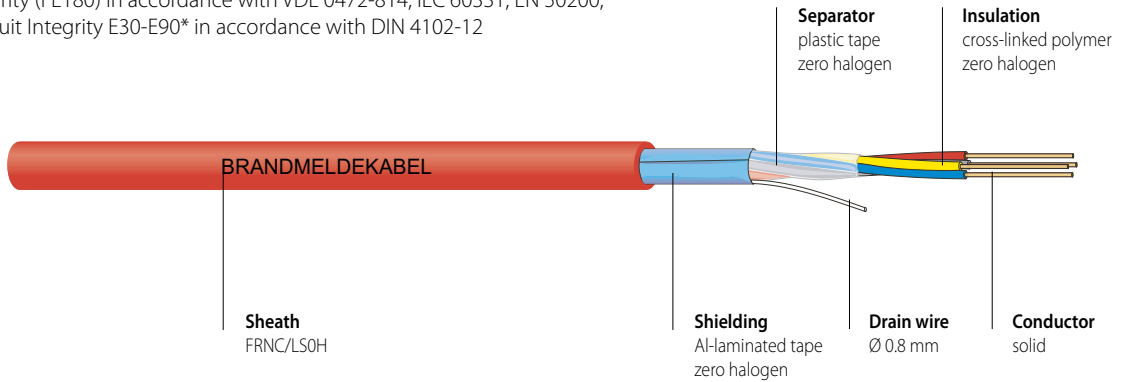

PRODUCT INFORMATION



APPLICATION

Cables with intrinsic fire resistance are installed in all areas that require special protection of people and equipment against fire and fire damages and where strict security requirements must be fulfilled. Suitable for indoor applications. For outdoor applications, protection must be provided against exposure to direct sunlight. The cable should only be laid directly in earth or water if a protective conduit is used. These cables correspond to the demands of System Circuit Integrity E30-E90* in accordance with DIN 4102-12. System Circuit Integrity is guaranteed at an operating voltage up to 110V. Permitted operating temperature at conductor of +70°C.

CONSTRUCTION

Conductor	Bare copper, solid, 0.8 mm diameter, VDE 0815
Insulation	Fire-resistant, cross-linked, high-performance Keram special compound, EN 50290-2-26
Core colours	VDE 0815, bundles identified by numbered tape
Separator	PEPT "Plastic Tape"
Shielding	Al-laminated tape with tinned copper drain wire Ø 0.8 mm
Outer sheath	Flame retardant polyolefin compound, VDE 0819 part 107, EN 50290-2-27 and VDE 0250-214 "HM 2"
Sheath colour	Red

ELECTRICAL PROPERTIES

Insulation resistance	minimum 100 MΩ x km
Loop resistance	maximum 73.2 Ω/km at 0.80 mm
Capacitance unbalance	maximum 120 nF/km at 800 Hz
Capacitance coupling	K maximum 200 pF/100m at 800 Hz
Rated voltage	maximum 225 V
Test voltage	500 V, 50 Hz Core/Core 2000 V, 50Hz, Core/Screen

GENERAL PROPERTIES

Minimum bending radius	during installation	7.5 x D (D = outer diameter)
	permanent installation	2.5 x D
Crush resistance		≥ 1000 N/10 cm
Impact		≥ 10 Impacts
Operating temperature	permanent installation	-30°C to +70°C
	during installation	-5°C to +50°C

- Zero halogen, non corrosive gases IEC 60754-2, EN 50267-2-2, VDE 0482-267-2-2
- Flame propagation IEC 60332-1-2, EN 60332-1-2, VDE 0482-332-1-2
- Flame spread IEC 60332-3-22/-24 Cat. A/C, EN 60332-3-22/-24 Cat. A/C, VDE 0482-332-3-22/24 Cat. A/C
- Smoke density IEC 61034-1/-2, EN 61034-1/-2, VDE 0482-1034-1/-2
- Circuit Integrity (FE/PH) IEC 60331-11/-21 (180minutes), VDE 0472 part 814 (FE180), IEC 60331-2, EN 50200, VDE 0482-200
- System Circuit Integrity (E30-E90)* DIN 4102 part 12, NBN 713-020 (Rf 1½)

* System Circuit Integrity is dependent on installation method.

JE-H(St)H...Bd FE180 E30-E90

Fire alarm cable max. 225V, Keram

halogen-free, with improved fire characteristics,
with reference to VDE 0815,

circuit integrity (FE180) in accordance with VDE 0472-814, IEC 60331, EN 50200,
System Circuit Integrity E30-E90* in accordance with DIN 4102-12

PRODUCT INFORMATION

Article No.	No. of cores x conductor diameter				Cu content kg/km	Total weight approx. kg/km	Outer diameter approx. mm	Fire load kWh/m
	n x mm							
188093	1	x	2	x 0.80	15	40	5.5	0.095
188098	2	x	2	x 0.80	25	56	6.0	0.123
188101	4	x	2	x 0.80	45	96	8.7	0.21
188103	8	x	2	x 0.80	85	218	13.7	0.52
188105	12	x	2	x 0.80	126	270	14.6	0.58
188107	16	x	2	x 0.80	166	337	16.0	0.69
188109	20	x	2	x 0.80	206	403	18.0	0.80
188112	32	x	2	x 0.80	326	570	21.8	1.02
188114	40	x	2	x 0.80	407	739	25.3	1.38
188116	52	x	2	x 0.80	529	906	27.6	1.59

Additional dimensions available on request.

* System Circuit Integrity is dependent on installation method.

PREVENTIVE FIRE PROTECTION

JE-H(St)HRH...Bd FE180 E30-E90

Fire alarm cable with steel wire braiding max. 225V, Keram

halogen-free, with improved fire characteristics,
with reference to VDE 0815,
circuit integrity (FE180) in accordance with VDE 0472-814, IEC 60331, EN 50200,
System Circuit Integrity E30-E90* in accordance with DIN 4102-12

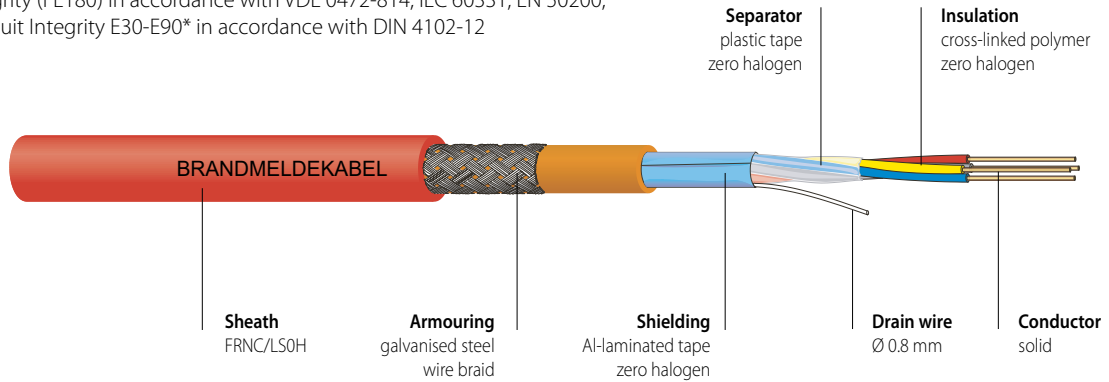

PRODUCT INFORMATION



APPLICATION

Cables with intrinsic fire resistance are installed in all areas that require special protection of people and equipment against fire and fire damages and where strict security requirements must be fulfilled. Suitable for indoor applications. For outdoor applications, protection must be provided against exposure to direct sunlight. The steel wire braiding serves as mechanical protection. The fire alarm cables correspond to the demands of System Circuit Integrity E30-E90* in accordance with DIN 4102-12. System Circuit Integrity is guaranteed at an operating voltage up to 110V. Permitted operating temperature at conductor of +70°C.

CONSTRUCTION

Conductor	Bare copper, solid, 0.8 mm diameter, VDE 0815
Insulation	Fire-resistant, cross-linked, high-performance Keram special compound, EN 50290-2-26
Core colours	According to VDE 0815, bundles identified by numbered tape
Separator	PEPT "Plastic Tape"
Shielding	Al-laminated tape with tinned copper drain wire Ø 0.8 mm
Inner sheath	Flame retardant polyolefin compound, VDE 0819 part 107, EN 50290-2-27 and VDE 0250-214 "HM2"
Armouring	Galvanised steel wire braid
Outer sheath	Flame retardant polyolefin compound, VDE 0819 part 107, EN 50290-2-27 and VDE 0250-214 "HM 2"
Sheath colour	Red

ELECTRICAL PROPERTIES

Insulation resistance	minimum 100 MΩ x km
Loop resistance	maximum 73.2 Ω/km at 0.8 mm
Capacitance unbalance	maximum 120 nF/km at 800 Hz
Capacitance coupling	K maximum 200 pF/100m at 800 Hz
Rated voltage	maximum 225 V
Test voltage	500 V, 50 Hz Core/Core 2000 V, 50Hz, Core/Screen

GENERAL PROPERTIES

Minimum bending radius	during installation	7.5 x D (D = outer diameter)
	permanent installation	2.5 x D
Crush resistance		≥ 1000 N/10 cm
Impact		≥ 10 impacts
Operating temperature	permanent installation	-30°C to +70°C
	during installation	-5°C to +50°C

Zero halogen,	
non corrosive gases	IEC 60754-2, EN 50267-2-2, VDE 0482-267-2-2
Flame propagation	IEC 60332-1-2, EN 60332-1-2, VDE 0482-332-1-2
Flame spread	IEC 60332-3-22/-24 Cat. A/C, EN 60332-3-22/-24 Cat. A/C, VDE 0482-332-3-22/24 Cat. A/C
Smoke density	IEC 61034-1/-2, EN 61034-1/-2, VDE 0482-1034-1/-2
Circuit integrity (FE/PH)	IEC 60331-11/-21 (180minutes), VDE 0472 part 814 (FE180), IEC 60331-2, EN 50200, VDE 0482-200
System Circuit Integrity (E30-E90)*	DIN 4102 part 12

* System Circuit Integrity is dependent on installation method.

JE-H(St)HRH...Bd FE180 E30-E90

Fire alarm cable with steel wire braiding max. 225V, Keram

halogen-free, with improved fire characteristics,

with reference to VDE 0815,

circuit integrity (FE180) in accordance with VDE 0472-814, IEC 60331, EN 50200,

System Circuit Integrity E30-E90* in accordance with DIN 4102-12

PRODUCT INFORMATION

Article No.	No. of cores x conductor diameter				Cu content kg/km	Total weight approx. kg/km	Outer diameter approx. mm	Fire load kWh/m
	n x mm							
	1	x	2	x 0.80	15	94	8.3	0.23
188119	2	x	2	x 0.80	25	117	9.0	0.26
188120	4	x	2	x 0.80	45	179	11.7	0.39
188127	8	x	2	x 0.80	85	404	18.0	0.93
188128	12	x	2	x 0.80	126	466	18.9	1.01
	16	x	2	x 0.80	166	550	20.3	1.16
188129	20	x	2	x 0.80	206	640	22.3	1.32
188346	32	x	2	x 0.80	326	877	26.5	1.72

Additional dimensions available on request.

* System Circuit Integrity is dependent on installation method.

PREVENTIVE FIRE PROTECTION

FO Universal ZGGFR Safety / U-DQ(ZN)BH

Safety cable E30

non metallic, water resistant, rodent protection,
in accordance with IEC 60332.1 and IEC 60332.3 C

30 minutes System Circuit Integrity* according to DIN 4102-12

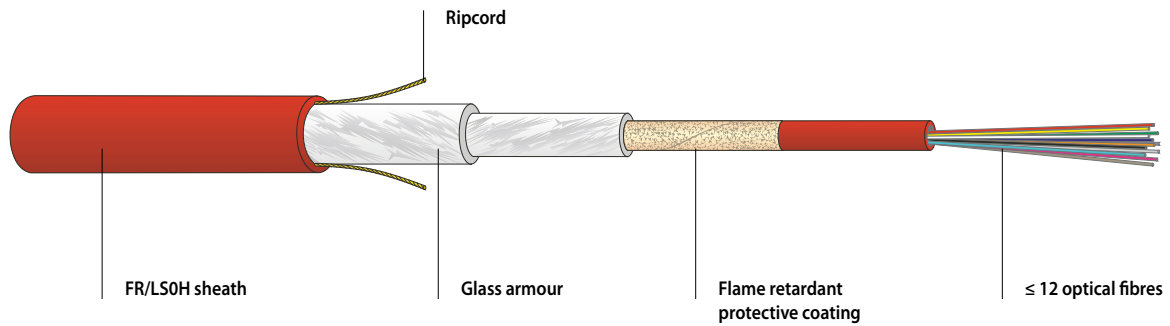

PRODUCT INFORMATION

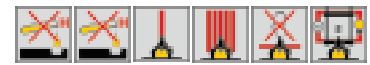

FEATURES

Non-metallic fibre optic safety cable with one central loose tube, up to 12 fibres. The optimal combination of flame retardant fibre coating and flame-inhibiting stabilizing elements ensures enhanced circuit integrity (System Circuit Integrity*) in case of fire for 30 minutes.

APPLICATION

Safety applications in tunnels, underground railways, banks, insurance companies, large scale industry. LAN backbones. Indoor and outdoor cabling. Can be installed in cable platforms, trays, ducts and vertical shafts. Can be spliced in FO distributors.

OPTICAL CHARACTERISTICS

The cables are available with different types of optical fibre (see Datwyler’s fibre data sheets).

MECHANICAL CHARACTERISTICS

Temperature range	storage	-25 / +70°C	IEC 60794-1-2 F1
	during installation	-10 / +50°C	
	in operation	-25 / +60°C	
Tensile performance	IEC 60794-1-2 E1		
Crush resistance	IEC 60794-1-2 E3		
Impact	IEC 60794-1-2 E4		
Repeated bending	IEC 60794-1-2 E6		
Torsion	IEC 60794-1-2 E7		
Bend	IEC 60794-1-2 E11		
Water penetration	IEC 60794-1-2 F5		

GENERAL CHARACTERISTICS

Imprint DATWYLER «cable type» «Datwyler designation» «DIN designation» «number of fibres» «fibre type» «additional text» «batch number» ~ ~ «meter marks» ~ ~

Zero halogen, non corrosive gases	IEC 60754-1/-2, EN 50267-2-1/-2-2, VDE 0482-267-2-1/-2-2
Flame retardant	IEC 60332-1-2, EN 60332-1-2, VDE 0482-332-1-2
Fire resistant (no flame propagation)	IEC 60332.3 C, EN 50266-2-4, VDE 0482-266-2-4
Minimum smoke emission	IEC 61034-1/-2, EN 61034-1/-2 (EN 50268-1/-2), VDE 0482-1034-1/-2 (VDE 0482-268-1/-2)
Circuit integrity (FE180)	IEC 60331, VDE 0472 part 814, EN 50200, EN 50362, VDE 0482-200, VDE 0482-362
System Circuit Integrity E30*	according to DIN 4102 part 12

* System Circuit Integrity is dependent on installation method

ACCESSORIES

To realize System Circuit Integrity E30, tested and certified fire safety system components are necessary.

FO Universal ZGGFR Safety / U-DQ(ZN)BH

Safety cable E30

non metallic, water resistant, rodent protection,
in accordance with IEC 60332.1 and IEC 60332.3 C
30 minutes System Circuit Integrity* according to DIN 4102-12

PRODUCT INFORMATION

Description	U-DQ(ZN)BH 1 x m	No. of fibres max.	Loose tubes	Sheath Ø mm	Weight kg/km	Bending radius mm	Tensile load N	Crush resistance		Fire load	
								continuous N	short term N	kWh/km	MJ/km
ZGGFR Safety	1 x 12	12	1	7.8	72	120	1000	2000	5000	301	1084

VERSIONS

U-DQ(ZN)BH 1 x m	Fibres number	Article No.	Article No.	Article No.	Article No.
Description		E9/125 G.652.D	G50/125 OM2	G50/125 OM3	G62.5/125 OM1
ZGGFR Safety 1 x 4	4	187288	186363	190604	186638
ZGGFR Safety 1 x 6	6	191867	186639	191851	190792
ZGGFR Safety 1 x 8	8	on request	190621	on request	on request
ZGGFR Safety 1 x 12	12	190719	187293	191796	187305

* System Circuit Integrity is dependent on installation method.

PREVENTIVE FIRE PROTECTION

FO Universal wbGGFR Safety / U-DQ(ZN)BH

Safety cable E30

non metallic, water resistant, rodent protection,
in accordance with IEC 60332.1 and IEC 60332.3 C

30 minutes System Circuit Integrity* according to DIN 4102-12

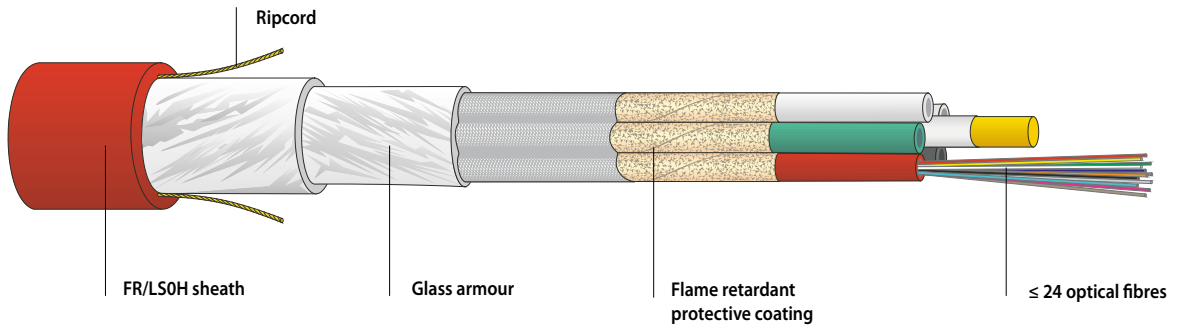

PRODUCT INFORMATION

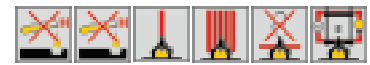

FEATURES

Non-metallic fibre optic safety cable with multiple loose tubes, up to 60 fibres. The optimal combination of flame retardant fibre coating and flame-inhibiting stabilizing elements ensures enhanced functional integrity (System Circuit Integrity*) in case of fire for 30 minutes.

APPLICATION

Safety applications in tunnels, underground railways, banks, insurance companies, large scale industry. LAN backbones. Indoor and outdoor cabling. Can be installed in cable platforms, trays, ducts and vertical shafts. Can be spliced in FO distributors.

OPTICAL CHARACTERISTICS

The cables are available with different types of optical fibre (see Datwyler’s fibre data sheets).

MECHANICAL CHARACTERISTICS

Temperature range	storage	-25 / +70°C	IEC 60794-1-2 F1
	during installation	-10 / +50°C	
	in operation	-25 / +60°C	
Tensile performance	IEC 60794-1-2 E1		
Crush resistance	IEC 60794-1-2 E3		
Repeated bending	IEC 60794-1-2 E6		
Torsion	IEC 60794-1-2 E7		
Bend	IEC 60794-1-2 E11		
Water penetration	IEC 60794-1-2 F5		

GENERAL CHARACTERISTICS

Imprint DATWYLER «cable type» «Datwyler designation» «DIN designation» «number of fibres» «fibre type» «additional text» «batch number» ~ ~ «meter marks» ~ ~

Zero halogen, non corrosive gases	IEC 60754-1/-2, EN 50267-2-1/-2-2, VDE 0482-267-2-1/-2-2
Flame retardant	IEC 60332-1-2, EN 60332-1-2, VDE 0482-332-1-2
Fire resistant (no flame propagation)	IEC 60332.3 C, EN 50266-2-4, VDE 0482-266-2-4
Minimum smoke emission	IEC 61034-1/-2, EN 61034-1/-2 (EN 50268-1/-2), VDE 0482-1034-1/-2 (VDE 0482-268-1/-2)
Circuit integrity (FE180)	IEC 60331, VDE 0472 part 814, EN 50200, EN 50362, VDE 0482-200, VDE 0482-362
System Circuit Integrity E30*	according to DIN 4102 part 12

* System Circuit Integrity is dependent on installation method

ACCESSORIES

To realize System Circuit Integrity E30, tested and certified fire safety system components are necessary.

FO Universal wbGGFR Safety / U-DQ(ZN)BH

Safety cable E30

non metallic, water resistant, rodent protection,
in accordance with IEC 60332.1 and IEC 60332.3 C
30 minutes System Circuit Integrity* according to DIN 4102-12

PRODUCT INFORMATION

Description U-DQ(ZN)BH n x m	No. of fibres max.	Loose tubes max.	Sheath Ø mm	Weight kg/km	Bending radius mm	Tensile load N	Crush resistance		Fire load	
							continuous N	short term N	kWh/km	MJ/km
wbGGFR Safety 2 x 12	24	2	12.5	166	190	6000	3000	5000	733	2639
wbGGFR Safety 3 x 12	36	3	12.5	168	190	6000	3000	5000	733	2639
wbGGFR Safety 4 x 12	48	4	12.5	170	190	6000	3000	5000	733	2639
wbGGFR Safety 5 x 12	60	5	12.5	166	190	6000	3000	5000	733	2639

VERSIONS

U-DQ(ZN)BH n x m Description	Fibres number	Article No. E9/125 G.652.D	Article No. G50/125 OM2	Article No. G50/125 OM3	Article No. G62.5/125 OM1
wbGGFR Safety 2 x 12	24	190223	187294	187360	on request
wbGGFR Safety 3 x 12	36	190224	on request	on request	on request
wbGGFR Safety 4 x 12	48	190225	192119	191191	on request
wbGGFR Safety 5 x 12	60	190226	on request	190605	on request

* System Circuit Integrity is dependent on installation method.

WUM support measure
for vertical cable installation



PRODUCT INFORMATION

APPLICATION Effective support measure for vertical installation of Datwyler safety cables with intrinsic fire resistance using the C-shaped rail 2970 SLD. Meandering cable laying is not necessary if the WUM is used (intervals: up to 3.5 m).

SCOPE OF DELIVERY Fire protection housing
Fastening set
Cartridge of fire protection filler
Mineral wool

NOTE The WUM E30 and WUM E90 can be used with all Datwyler Keram cable types (N)HXH / (N)HXH CL / (N)HXCH FE180/E30-E60, (N)HXH / (N)HXCH FE180/E90, JE-H(St)H FE180/E30-E90 and JE-H(St)HRH FE180/E30-E90.

FUNCTION The WUM protects the clamp of safety cables with intrinsic fire resistance, thereby supporting the vertically laid cabling in the event of fire.

INSTALLATION The WUM is slipped over the strap clamp that attaches the cable to the C-shaped rail at intervals of up to 3.5 m. It is attached to the C-shaped rail by means of slide nuts and threaded rods. Hollow spaces are filled with mineral wool. The cable inlet and back of the WUM are sealed with fire protection filler.

Article No.	Type	Outer dimensions mm	for C-shaped rail 2970 SLD width (mm)	PU
1301276	WUM 300 E30	100 x 370 x 135	300	1 pc.
1301278	WUM 400 E30	100 x 470 x 135	400	1 pc.
1301277	WUM 500 E30	100 x 570 x 135	500	1 pc.
1301275	WUM 300 E90	200 x 470 x 185	300	1 pc.
1301274	WUM 400 E90	200 x 570 x 185	400	1 pc.
1301273	WUM 500 E90	200 x 670 x 185	500	1 pc.

Accessories

Article No.	Description	PU
301370	Fire protection filler	15 kg plastic bucket
1300467	Fire protection filler SP cartridge (310 ml)	400 g cartridge



PRODUCT INFORMATION

APPLICATION

For laying single and multiple cables under ceilings or on walls. System Circuit Integrity is achieved for Datwyler Keram cable types (N)HXH / (N)HXH CL / (N)HXCH FE180/E30-E60. Maximum permissible fixing distance: up to 1,250 mm. Maximum load: 10 kg/m.

TECHNICAL DATA

Material Steel wire, mesh 50x100 mm, flange height 54 mm
 Corrosion protection Galvanised (electrolytic) in accordance with DIN 50961 (zinc layer 18-20 µ), others on request
 Approvals VDE 0639, CEI 1537

Wire mesh cable tray

Article No.	Type	Nominal width (mm)	kg/m	PU
1300999	GR 54-100	100	1.29	3 m
1301078	GR 54-150	150	1.53	3 m
1301079	GR 54-200	200	1.77	3 m

Note: For cutting, a bolt cutter with "offset cutting" must be used.

Ceiling console, screwless

Corrosion protection: Sendzimir galvanised in accordance with DIN 17162 (zinc coating, approx. 21 µ). Other on request

Article No.	Type	Height x width (mm)	for	kg/piece	PU
1301080	GR DKS 150	approx. 210 x 230	GR 54-100	0.68	1 pc.
1301081	GR DKS 200	approx. 210 x 280	GR 54-150	0.75	1 pc.
1301082	GR DKS 300	approx. 210 x 380	GR 54-200	0.87	1 pc.

Wall console, screwless

Corrosion protection: Sendzimir galvanised in accordance with DIN 17162 (zinc coating, approx. 21 µ). Other on request

Article No.	Type	Height x width (mm)	for	kg/piece	PU
1301083	GR WKS 150	approx. 170 x 230	GR 54-100	0.46	1 pc.
1301084	GR WKS 200	approx. 170 x 280	GR 54-150	0.52	1 pc.
1301085	GR WKS 300	approx. 170 x 380	GR 54-200	0.64	1 pc.

PRODUCT INFORMATION

Wire mesh cable tray accessories

Article No.	Type	Description	Information
1301090	GRVB	ED 275 and KITASSTR	Contents: 50 push connectors ED 275, 50 snap connectors KITASSTR
		for straight joints	For each push connection provided: - 10 pcs. KITASSTR - 2 pcs. ED 275
		for 90° angles	For each 90° angle for barred groove 100 provided: - 6 pcs. KITASSTR - 1.5 pcs. ED 275 For each 90° angle for barred groove 150/200 provided: - 8 pcs. KITASSTR - 2 pcs. ED 275
		for T-junctions	For each T-junction for a barred groove provided: - 4 pcs. KITASSTR
		for cross joints	For each cross joint provided: - 6 pcs. KITASSTR - 2 pcs. ED 275

Wire mesh cable tray fixings

Article No.	Type	Description	Information
1301096	GAS 8x220	Thread suspension set M8x220	For thread attachment to ceiling console GR DKS Contents: 13 thread rails M8x1000, 50 KMU LF8 plugs, 100 underlay disks, nuts M8 (recommended tool set: SMu 8 SM, drillbit: SDS2)
1301097	GS 8x1000	Threaded rod M8x1000	For thread attachment to wall console GR WKS PU 50 pieces
1301098	GZS	Threaded rod attachment accessories	Accessories for thread rod suspension attachment GS 8x1000 Contents: 100 underlay disks, M8 nuts, KMU LF8 plugs, (recommended tool set SMu 8 SM, drillbit SDS2)



PRODUCT INFORMATION

APPLICATION

For laying single and multiple cables under ceilings or on walls.
System Circuit Integrity is achieved for Datwyler Keram cable types (N)HXH / (N)HXH CL / (N)HXCH FE180/E30-E60, (N)HXH / (N)HXCH FE180/E90, JE-H(St)H FE180/E30-E90, JE-H(St)HRH FE180/E30-E90.
This cable tray system does not need threaded rod suspension.
Maximum permissible fixing distance: up to 1500 mm.
Maximum load: 20 kg/m.

TECHNICAL DATA

Material Steel, galvanized
Nominal size 60 x 100 mm, 60 x 200 mm, 60 x 300 mm, 60 x 400 mm

Cable tray

Article No.	Type	Nominal size	PU
3800032	RG 60-10S	100 mm	1 pc. = 3 m
3800033	RG 60-20S	200 mm	1 pc. = 3 m
3800129	RG 60-20S 45° angle	200 mm	1 pc.
3800034	RG 60-30S	300 mm	1 pc. = 3 m
3800035	RG 60-40S	400 mm	1 pc. = 3 m

Lateral connector

3800036	60 RGV-BS 60S	60 mm	1 pc.
---------	---------------	-------	-------

Bottom connector

3800038	VB-BS 10S	100 mm	1 pc.
3800039	VB-BS 20S	200 mm	1 pc.
3800044	VB-BS 30S	300 mm	1 pc.
3800045	VB-BS 40S	400 mm	1 pc.

Screws for fixing the tray on the console

3800040	screw set KLAR	M6	100 pcs.
---------	----------------	----	----------

Lateral reinforcement (necessary per console)

3800041	ALS-BS S		1 pc.
---------	----------	--	-------

Cable trays

PRODUCT INFORMATION

Plugs

Article No.	Type	Nominal size	PU
3800077	M10x10 SD 10/10	M10x10	100 pcs.

Wall consoles

3800042	KWMS 010F	100 mm	1 pc.
3800043	KWMS 020F	200 mm	1 pc.
3800047	KWMS 030F	300 mm	1 pc.
3800048	KWMS 040F	400 mm	1 pc.

Consoles for hangers

3800049	KUMS 010F	100 mm	1 pc.
3800050	KUMS 020F	200 mm	1 pc.
3800051	KUMS 030F	300 mm	1 pc.
3800053	KUMS 040F	400 mm	1 pc.

Hangers

3800054	KDU 52-03F	300 mm	1 pc.
3800055	KDU 52-04F	400 mm	1 pc.
3800056	KDU 52-05F	500 mm	1 pc.
3800057	KDU 52-06F	600 mm	1 pc.
3800058	KDU 52-07F	700 mm	1 pc.
3800059	KDU 52-08F	800 mm	1 pc.
3800060	KDU 52-09F	900 mm	1 pc.
3800061	KDU 52-10F	1000 mm	1 pc.

Accessories to fix the consoles on hangers

3800072	Ring washer US 10x21	M10x21	100 pcs.
3800073	Nut SEM 10	M10	100 pcs.
3800074	Screw KLS 10x20	M10x20	100 pcs.

Single clamp

Type SAS

fixing distance ≤ 1200 / 600 mm



Fig. 1: Type SAS single clamp



Fig. 2: Type SAS single clamp, pre-assembled with fire protection plugs type K6x5

PRODUCT INFORMATION

APPLICATION

For laying single and multiple cables on ceilings or walls. System Circuit Integrity is achieved for Datwyler Keram cable types (N)HXH / (N)HXH CL / (N)HXCH FE180/E30-E60, (N)HXH / (N)HXCH FE180/E90, JE-H(St)H FE180/E30-E90, JE-H(St)HRH FE180/E30-E90.

Type SAS single clamp (Fig. 1)

Article No.	Clamp type	Cable ø (mm)	PU
1300016	SAS 6 D	5 - 6	100 pcs.
1300017	SAS 8 D	7 - 8	100 pcs.
1300018	SAS 10 D	9 - 10	100 pcs.
1300019	SAS 12 D	11 - 12	100 pcs.
1300020	SAS 14 D	13 - 14	100 pcs.
1300021	SAS 16 D	15 - 16	100 pcs.
1300022	SAS 18 D	17 - 18	100 pcs.
1300023	SAS 20 D	19 - 20	100 pcs.
1300024	SAS 22 D	21 - 22	100 pcs.
1300025	SAS 24 D	23 - 24	100 pcs.
1300026	SAS 26 D	25 - 26	100 pcs.
1300027	SAS 28 D	27 - 28	100 pcs.
1300028	SAS 30 D	29 - 30	100 pcs.
1300251	SAS 38 D new	29 - 38	25 pcs.
1300252	SAS 47 D new	38 - 47	20 pcs.
1300234	SAS 55 D new	47 - 55	20 pcs.
1300250	SAS 60 D new	55 - 60	20 pcs.

To attach the single clamp, we recommend the use of Datwyler fire protection plugs K6x5 and the Datwyler tool set SMu 6 SM for quick assembly.

Type SAS single clamp, pre-assembled with fire protection plugs type K6x5, 30 mm (Fig. 2)

1300956	SAS 8 D - K6x5	7 - 8	100 pcs. set*
1300957	SAS 12 D - K6x5	11 - 12	100 pcs. set*
1300958	SAS 14 D - K6x5	13 - 14	100 pcs. set*
1300959	SAS 16 D - K6x5	15 - 16	100 pcs. set*

Required tool set: SMu 6 SM. *The required SDS1 32 mm drillbit is included in the set.

Type SAS V4A single clamp, steel grade 1.4571 (similar to Fig. 1) - stainless steel plugs available on request

SAS 19 D - V4A	15 - 19	50 pcs.
SAS 24 D - V4A	20 - 24	50 pcs.
SAS 29 D - V4A	25 - 29	50 pcs.
SAS 38 D - V4A	30 - 38	25 pcs.
SAS 47 D - V4A	39 - 47	20 pcs.
SAS 55 D - V4A	48 - 55	20 pcs.
SAS 63 D - V4A	56 - 63	20 pcs.

Please also see our optional installation methods: installation of cable bundles in clamps, installation in steel armoured conduits, etc.

PREVENTIVE FIRE PROTECTION

Strap clamp

Type B without trough

fixing distance ≤ 1200 / 800 / 600 mm



Type B strap clamp without trough



C-shaped rail 2970/2SLD

PRODUCT INFORMATION

APPLICATION

For laying several cables independently in parallel on ceilings and walls. System Circuit Integrity is achieved for Datwyler Keram cable types (N)HXH / (N)HXH CL / (N)HXCH FE180/E30-E60, (N)HXH / (N)HXCH FE180/E90, JE-H(St)H FE180/E30-E90, JE-H(St)HRH FE180/E30-E90.

Article No.	Clamp type	Cable ø (mm)	PU
1300043	B 12 D	6 - 12	100 pcs.
1300044	B 14 D	10 - 14	100 pcs.
1300045	B 16 D	12 - 16	100 pcs.
1300046	B 18 D	14 - 18	100 pcs.
1300047	B 22 D	18 - 22	100 pcs.
1300048	B 26 D	22 - 26	100 pcs.
1300049	B 30 D	26 - 30	100 pcs.
1300050	B 34 D	30 - 34	100 pcs.
1300051	B 38 D	34 - 38	100 pcs.
1300052	B 42 D	38 - 42	100 pcs.
1300053	B 46 D	42 - 46	100 pcs.
1300054	B 50 D	46 - 50	50 pcs.
1300055	B 54 D	50 - 54	50 pcs.
1300056	B 58 D	54 - 58	50 pcs.
1300057	B 64 D	58 - 64	50 pcs.
1300058	B 70 D	64 - 70	50 pcs.
1300059	B 76 D	70 - 76	50 pcs.
1300060	B 82 D	76 - 82	50 pcs.
1300061	B 90 D	82 - 90	50 pcs.
1300062	B 100 D	90 - 100	25 pcs.
1300063	B 110 D	100 - 110	25 pcs.

The C-shaped rail 2970/2 SLD is required to fix the strap clamps.

Article No.	C-shaped rail	Slit width	PU (set)
1300064	2970/2 SLD	16 mm	as required

C-shaped rails come in lengths of 2 m. Other lengths are available on request.
For assembly of the C-shaped rail, Datwyler recommends fire protection plugs KDM 30 mm.
Please do not exceed the maximum tensile force on the fire protection plugs!
For fast assembly of the C-shaped rail, Datwyler recommends the tool set SWM-SM.

Please also see our optional installation methods:
installation of cable bundles in clamps, installation in steel armoured conduits, etc.

Strap clamp

Type B with trough

fixing distance ≤ 1200 / 800 / 600 mm



Type B strap clamp with trough



C-shaped rail 2970/2SLD

PRODUCT INFORMATION

APPLICATION

For laying several cables independently or in bundles in parallel on ceilings and walls. System Circuit Integrity is achieved for Datwyler Keram cable types (N)HXH / (N)HXH CL / (N)HXCH FE180/E30-E60, (N)HXH / (N)HXCH FE180/E90, JE-H(St)H FE180/E30-E90, JE-H(St)HRH FE180/E30-E90 (up to 800 mm).

Article No.	Clamp type			Cable ø (mm)	PU
1300045	B	16	D	8 – 13	100 pcs.
1300065	LW	16	D		100 pcs.
1300047	B	22	D	13 – 19	100 pcs.
1300066	LW	22	D		100 pcs.
1300048	B	26	D	19 – 23	100 pcs.
1300067	LW	26	D		100 pcs.
1300050	B	34	D	23 – 31	100 pcs.
1300068	LW	34	D		100 pcs.
1300051	B	38	D	31 – 36	100 pcs.
1300069	LW	38	D		100 pcs.
1300052	B	42	D	36 – 40	100 pcs.
1300070	LW	42	D		100 pcs.
1300053	B	46	D	40 – 43	100 pcs.
1300071	LW	46	D		100 pcs.
1300054	B	50	D	43 – 47	50 pcs.
1300072	LW	50	D		50 pcs.
1300055	B	54	D	47 – 51	50 pcs.
1300073	LW	54	D		50 pcs.

The C-shaped rail 2970/2 SLD is required to fix the strap clamps.

Article No.	C-shaped rail	Slit width	PU (set)
1300064	2970/2 SLD	16 mm	as required

C-shaped rails come in lengths of 2 m. Other lengths are available on request.

For assembly of the C-shaped rail, Datwyler recommends fire protection plugs KDM 30 mm. Please do not exceed the maximum tensile force on the fire protection plugs!
For fast assembly of the C-shaped rail, Datwyler recommends the tool set SWM-SM.

Please also see our optional installation methods:
installation of cable bundles in clamps, installation in steel armoured conduits, etc.

PREVENTIVE FIRE PROTECTION

Multi cable support E30-E90

Hermann clamp for wall and ceiling installation

fixing distances ≤ 800 mm / ≤ 600 mm



Multi cable support E30-E90
Type Hermann clamp



Multi cable support E30-E90
Type Hermann clamp S

PRODUCT INFORMATION

APPLICATION

For laying multiple cables on ceilings or walls. System Circuit Integrity is achieved for Datwyler Keram cable types (N)HXH / (N)HXH CL / (N)HXCH FE180/E30-E60, (N)HXH / (N)HXCH FE180/E90, JE-H(St)H FE180/E30-E90, JE-H(St)HRH FE180/E30-E90.

SCOPE OF DELIVERY

Set consisting of SHUD multi cable supports (Hermann clamps), with fire protection plugs KDM 30 mm.

Drill bit and tool set supplied separately.

Recommended drill bit: SDS1; recommended tool set: SWM-SM 50.

Hermann clamp V2A (1.4301):

Stainless steel plugs - available on request.

TECHNICAL DATA

Material

Inner dimensions

Outer dimensions

Maximum load

Fixing distance

Hermann clamp

Sendzimir galvanised sheet

approx. 110 x 75 x 80 mm

approx. 125 x 95 x 80 mm

6 kg/m or 3 kg/m

≤ 800 mm or ≤ 600 mm

Hermann clamp S

Sendzimir galvanised sheet

approx. 70 x 52 x 56 mm

approx. 84 x 73 x 56 mm

3 kg/m

≤ 800 mm or ≤ 600 mm

Article No.	Clamp type	PU
3800206	Hermann clamp	10 pcs./set
3800207	Hermann clamp	50 pcs./set
3800208	Hermann clamp	100 pcs./set
1300346	Hermann clamp	750 pcs./skeleton box (without plugs)
3800199	Hermann clamp S	10 pcs./set
3800200	Hermann clamp S	50 pcs./set
3800201	Hermann clamp S	100 pcs./set
1301279	Hermann clamp S	1750 pcs./skeleton box (without plugs)
1301240	Hermann clamp V2A (1.4301)	10 pcs./set
3800156	Hermann clamp V4A (1.4571)	10 pcs./set
3800157	Hermann clamp SV4A (1.4571)	10 pcs./set

For quick assembly of the SHUD Hermann clamp Datwyler recommends the tool set SWM-SM 50.

Please also see our optional installation methods:

installation of cable bundles in clamps, installation in steel armoured conduits, etc.



Cable joint E30-E90

PRODUCT INFORMATION

APPLICATION	For connecting two Datwyler Keram cable types (N)HXH / (N)HXH CL / (N)HXCH FE180/E30-E60, (N)HXH / (N)HXCH FE180/E90. The cable joint provides the relevant circuit integrity of the cables.
SCOPE OF DELIVERY	Full shrink tube, without squeeze connections.
CONSTRUCTION	The joint consist of several heat-absorbing inner joints (depending on the number of conductor connections), an external joint and several insulating tubes that serve as flame barrier.
ASSEMBLY	Cables are prepared as usual, with offset connection order. The joint is installed using any common warm air device. Detailed assembly instructions are provided with each joint. Mandrel crimping is not permitted for crimped connections.

For Datwyler Keram type (N)HXH-O 4-conductor cables or NHXH-J 5-conductor cables

Article No.	Dimensions	Description	PU
1300310	from 1.5 mm ² up to 4 mm ²	joint SMH4	1 pc.
1300311	from 6 mm ² up to 10 mm ²	joint SMH4	1 pc.
1300312	from 16 mm ² up to 25 mm ²	joint SMH4	1 pc.
1300313	from 35 mm ² up to 50 mm ²	joint SMH4	1 pc.
1300314	from 70 mm ² up to 95 mm ²	joint SMH4	1 pc.
1300315	from 120 mm ² up to 150 mm ²	joint SMH4	1 pc.
1300316	from 185 mm ² up to 240 mm ²	joint SMH4	1 pc.

For Datwyler Keram type (N)HXCH cables with concentric conductor

1300317	from 1.5/1.5 mm ² up to 4/4 mm ²	joint SMHC4	1 pc.
1300318	from 6/6 mm ² up to 10/10 mm ²	joint SMHC4	1 pc.
1300319	from 16/16 mm ² up to 25/16 mm ²	joint SMHC4	1 pc.
1300320	from 35/16 mm ² up to 50/25 mm ²	joint SMHC4	1 pc.
1300321	from 70/35 mm ² up to 95/50 mm ²	joint SMHC4	1 pc.
1300322	from 120/70 mm ² up to 150/70 mm ²	joint SMHC4	1 pc.
1300323	from 185/95 mm ² up to 240/120 mm ²	joint SMHC4	1 pc.

Distribution box

E30-E90, type Hercules



Hercules distribution box E30-E90



Hercules cover
AHD E30-E90

PRODUCT INFORMATION

APPLICATION

Distribution box or cover for power current and low current in accordance with DIN 4102-12 to protect commercial distribution/branch boxes and sub-distribution boxes against the effects of fire for a period of 30 or 90 minutes (System Circuit Integrity class E30 or E90), e.g. emergency lighting, alarm circuits and fire announcement systems, fire alarm systems, etc.

SCOPE OF DELIVERY

Hercules cover box E30-E90 Typ AHD...
with mounting angles, screws, cartridge of fire protection filler

Hercules distribution box E30-E90 Typ HS... (power current distribution box)
with mounting screws, cartridge of fire protection filler, top hat rail 35 x 7.5 x 250 mm.

Hercules distribution box E30-E90 Typ HI... (low current distribution box)
with mounting screws, cartridge of fire protection filler, QSA back mount frame ... x 105 x 50 mm.
(Quante: depth 30 mm, pitch: 27.5 mm)

NOTE

The Hercules distribution box or cover E30-E90 can be used for all Datwyler Keram cable types (N)HXH / (N)HXCH FE 180/E30-E60, (N)HXH / (N)HXCH FE 180/E90, JE-H(ST)H FE180/E30-E90, JE-H(ST)HRH FE180/E30-E90.

FUNCTION

Connections and branches of power current and low current.
Please note that due to the selectivity of safety circuits or in the case of a decrease in cross section, a corresponding circuit breaker must be installed.

INSTALLATION

The time required for assembly is about 10 minutes. The screws are screwed into predrilled holes without plugs. The cable inlets and outlets are sealed with the fire protection filler.

Article No.	Type	Outer dimensions (mm)	Inner dimensions (mm)	Top hat rail / frame	PU
Hercules cover AHD E30-E90					
301382	AHD 263013 E90	340 x 380 x 220	260 x 300 x 130	(empty, without base)	1 pc.
Hercules distribution box E30-E90 with top hat rail					
301375	HS 263013 E90	340 x 380 x 220	260 x 300 x 130	35 x 7.5 1-row	1 pc.
301376	HS 353013 E90	430 x 380 x 220	350 x 300 x 130	35 x 7.5 2-rows	1 pc.
301377	HS 523013 E90	600 x 380 x 220	520 x 300 x 130	35 x 7.5, 3-rows	1 pc.
Hercules distribution box E30-E90 with QSA trough					
301378	HI 263013 E90	340 x 380 x 220	260 x 300 x 130	156 x 105 x 50 (6 strips)	1 pc.
301379	HI 353013 E90	430 x 380 x 220	350 x 300 x 130	291 x 105 x 50 (11 strips)	1 pc.
301380	HI 523013 E90	600 x 380 x 220	520 x 300 x 130	359 x 105 x 50 (13 strips)	1 pc.
Article No.	Accessories/Description		PU		
301370	Fire protection filler		15 kg plastic bucket		
1300467	Fire protection filler SP cartridge (310 ml)		400 g cartridge		



Fuse element for VAD



VAD ... E30-E90

PRODUCT INFORMATION

APPLICATION	Connection / terminal box, tested on the basis of DIN 4102-12, System Circuit Integrity class E30.	
SCOPE OF DELIVERY	Halogen-free plastic box, cable glands, ceramic clamps, mounting rail and fire protection plugs.	
TECHNICAL DATA	Material	Halogen-free special compound, fail-safe
	Colour	Orange
	Protection class	IP 54
ACCESSORIES	Fuse element for VAD AC 230V fuse holder 5 x 20 mm with 2A fuse.	

Connection / terminal box VAD ... E30-E90

Article No.	Type	Outer dimensions (mm)	Dimensions	For branches up to	PU
301372	VAD 5x6 E30-E90	100 x 100 x 50	5 x 0.5-6 mm ²	1.5 mm ²	1 pc.
301373	VAD 3x10 E30-E90	100 x 100 x 50	3 x 1.5-10 mm ²	4 mm ²	1 pc.
301381	VAD 8x6 E30-E90	165 x 165 x 76	8 x 0.5-6 mm ²	1.5 mm ²	1 pc.

ACCESSORIES

Article No.	Description	Dimensions (mm)	PU
660302	AC 230V fuse holder 5 x 20 mm	L x W x H 40 x 20 x 20	1 pc.

Distribution box

E30, type AD



AD E30

PRODUCT INFORMATION

APPLICATION

Branch, connection or terminal box. Tested on the basis of DIN 4102-12, System Circuit Integrity class E30.
Distribution box for emergency lighting or alarm systems.
Connection box e.g. for smoke and heat extraction systems in damp areas (underground car parks, industry, etc.)

SCOPE OF DELIVERY

Box and mounting rail for feedthrough terminals.
Cable glands on request.

TECHNICAL DATA

Material	Halogen-free, fire resistant special compound
Systems test	In accordance with DIN 4102-12, System Circuit Integrity class E30
Wiring assembly	On request
Cable inlets	Available in various configurations
Colour	Orange
Protection class	IP 54

Distribution box AD E30

Article No.	Type	Outer dimensions (mm)	Dimensions	PU
on request	AD E30	130 x 130 x 108	2.5 - 6 mm ²	1 pc.
on request	AD E30	160 x 160 x 108	2.5 - 6 mm ²	1 pc.
on request	AD E30	200 x 200 x 108	2.5 - 6 mm ²	1 pc.
on request	AD E30	200 x 400 x 108 (twin-box, 6 inlets)	2.5 - 6 mm ²	1 pc.

Emergency lighting

Type BNL

Emergency lighting/
escape route signage

PRODUCT INFORMATION

APPLICATION	Combined emergency lighting/escape route signage for road tunnels. Datwyler safety cables with intrinsic fire resistance / enhanced circuit integrity E90 are recommended for power supply.
TECHNICAL DATA	Housing made of V4A steel, material quality 1.4571 Available as surface or flush-mount version Protection class IP65 Safety glass front cover Quick-release fasteners Silicone sealing Stainless cable inlets, 15 mm diameter Escape route signage: light source 2 x 11 Watt TC-L Emergency lighting: 150 Watt halogen lamp, type R7S, with asymmetrical reflector
SCOPE OF DELIVERY	Combined emergency lighting/escape route signage including fastening devices.
INSTALLATION	Surface or flush-mount.

Article No.	Type	Dimensions	PU
		(H x W x D) mm	
on request	BNL / surface mount	560 x 400 x 110	1 pc.
on request	BNL / flush-mount	560 x 400 x 110	1 pc.

Please also take a look at our tunnel tunnel distribution box and tunnel clamp.

E0 Multi-cable support for wall and ceiling installations

in accordance with MLAR 11/2005 3.5.3



PRODUCT INFORMATION

APPLICATION

For fire-safe installation of multiple cables or lines along ceilings or walls above fireproof ceilings in accordance with MLAR 11/2005. (Not for System Circuit Integrity!)
Load capacity of 1.8 kg/support or 6 kg/m (mounting distance of 30 cm).

Excerpt from MLAR 11/2005 3.5.3.:
The special requirements pertaining to fireproof fasteners for lines installed in the area between floor slabs and suspended ceilings must be observed.

SCOPE OF DELIVERY

Set consists of multi-cable supports E0 and fire protection plugs KDM 30 mm.

Drill bit and tool set supplied separately.
Recommended drill bit: SDS1.
Recommended tool set: SWM-SM 50.

TECHNICAL DATA

Material	Sendzimir galvanised steel							
Inner dimensions	E0	approx. 80 x 45 x 33 mm					E0 S	approx. 55 x 35 x 33 mm
Outer dimensions		approx. 87 x 60 x 33 mm						approx. 63 x 45 x 33 mm
Cable load	Installation spacing	30	40	50	60	70	80	cm
	Cable weight	6.0	4.5	3.6	3.0	2.6	2.3	kg/m

Multi-cable support E0 and E0 S

Article No.	Type	Inner dimensions (mm)	Outer dimensions (mm)	PU
3800086	E0 multi-cable support	approx. 80 x 45 x 33	approx. 87 x 60 x 33	25 pcs/set
3800087	E0 S multi-cable support	approx. 55 x 35 x 33	approx. 63 x 45 x 33	50 pcs/set

**Multi-cable support
Hermann clamp type F
for wall and ceiling installations**

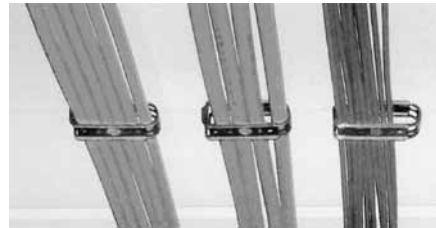

PRODUCT INFORMATION

APPLICATION

For fire-safe installation of multiple cables or lines along ceilings or walls above fireproof ceilings in accordance with MLAR 11/2005.
Load capacity of 1.0 kg/support or 3.6 kg/m (mounting distance of 30 cm).
(Suitable for about 30 pcs. of Datwyler data cable CU 7150 4P Multimedia)
Maximum cable diameter: 20 mm.

SCOPE OF DELIVERY

Set consists of multi-cable supports Hermann clamp type F and fire protection plugs KDM 30 mm.

Drill bit and tool set supplied separately.
Recommended drill bit: SDS1.
Recommended tool set: SWM-SM 50.

TECHNICAL DATA

Material Sendzimir galvanised steel

Inner dimensions approx. 80 x 22 x 35 mm

Outer dimensions approx. 90 x 27 x 35 mm

Cable load	Installation spacing	30	40	50	60	70	80	cm
	Cable weight	3.6	2.7	2.1	1.8	1.5	1.3	kg/m

We recommend the Datwyler tool set SWM-SM 50 to shorten the installation time of Hermann clamp Typ F.

Multi-cable support Hermann clamp type F

Article No.	Type	Inner dimensions (mm)	Outer dimensions (mm)	PU
3800294	Hermann clamp type F	approx. 80 x 22 x 35	approx. 90 x 27x 35	50 pcs./set

Fire protection plugs



K 6x5
30 mm embedment depth



K 6x110
K 6x80



KDM
30 mm embedment depth

PRODUCT INFORMATION

APPLICATION

For installation of cable systems with enhanced circuit integrity (System Circuit Integrity).

NOTE

The fire protection plugs are suitable for applications in concrete.
In order to guarantee the specified strength of the fire protection plugs, ensure that the drill holes have the specified depth.
Please use the drill bit that is supplied with the plug set to meet the correct hole depth.

Article No.	Plug	Mounting of	Set information / recommendations
1300953	Plug set K6x5 30 mm	SAS single clamps, Single/distance clamps with M6 thread	Set contains 200 K6x5 and SDS1 drill bit (required). Recommended tool: set SM 6 SM.
1300954	Plug set KDM 30 mm	Single/distance clamps with continuous hole 19-63 mm, Hermann clamp	Set contains 200 KDM and SDS1 drill bit (required). Recommended tool set: SWS-SM or SWS-SM 50.
1300954	Plug set KDM 30 mm	Shaped rails 2970/2 SLD (for laying strap clamps)	Set contains 200 KDM and SDS1 drill bit (required). Recommended tool set: SWS-SM
301369	Plugs K6x80	Special mounting on insulated ceilings or walls with insulation thickness up to 75mm	Set contains 100 K6x80 (for use with standard drill bit). Minimum required depth of 30mm to be guaranteed by the depth gauge on the drilling machine. Recommended tool set: EWA 6x5 SM.
1300448	Plugs K6x105	Special mounting on insulated ceilings or walls with insulation thickness up to 105mm	Set contains 100 K6x110 (for use with standard drill bit). Minimum required depth of 30mm to be guaranteed by the depth gauge on the drilling machine. Recommended tool set: EWA 6x5 SM.



SWM-SM
SWS-SM 50



SMu 6 SM



SDS 1 32 mm

PRODUCT INFORMATION

APPLICATION

These special drill bits enable holes to be drilled to the required depth.

ADVANTAGES

Ensures the required hole depth and

- less working time
- less drilling
- longer lasting drill bits

Article No.	Drill bit	Required for	PU
1300962	SDS1	plugs K6x5 and KDM	1 pc.

Article No.	Tool set	Recommended for	PU
1300961	SWM-SM	plugs KDM (hammer drill)	1 pc.
1300963	SMu 6 SM	"preassembled clamp" (hammer drill)	1 pc.
1300860	SWM-SM 50	Hermann clamp (hammer drill)	1 pc.

PREVENTIVE FIRE PROTECTION

Fire protection screws, special plugs, identification signs



MMS-P 7,5/45
40 mm embedment
depth



MMS-St 6/60
40mm embedment
depth



HMS 5/40
30mm embedment
depth



Gas concrete plugs
PBD M 6x10



Identification sign

PRODUCT INFORMATION

APPLICATION

For installation of safety cable systems with enhanced circuit integrity (System Circuit Integrity).

NOTE

The mounting screws are suitable for applications in lime-sand bricks and aerated lime-sand bricks, red bricks and concrete.

The gas concrete plugs are suitable for gas concrete P3.3 or better.

Article No.	Mounting screws	Mounting of	Set information / recommendations
1301218	HMS 5/40	SAS single clamps, simple/distancing clamps with M6 thread	Set contains 200 mounting screws. Bore hole outer diameter is 4 mm. Required for assembly: T-drive adapter "20".
3800097	HMS-St 6/60	SAS single clamps, simple/distancing clamps with M6 thread	Set contains 100 mounting screws. Bore hole outer diameter is 6 mm. Required for assembly: wrench / nut SW 10.
1300461	MMS-P 7.5/45	Shaped rails 2970/2 SLD (for laying strap clamps), Hermann clamps	Set contains 100 mounting screws Bore hole outer diameter is 6mm. Required for assembly: T-drive adapter "40".
1300479	Cabling system identification sign	For permanent identification of a DIN 4102-12 compliant cabling system	Set contains 10 identification signs.

Article No.	Special plugs	Mounting of	Set information / recommendations
1301301	PBD M 6x10	Simple/distancing clamps shaped rails, Hermann clamps, cable trays	Set contains 25 gas concrete plugs. Recommended tool set: "EWP 6x10 ..."
1301306	PBD M 10x10	Heavy cable trays	Set contains 25 gas concrete plugs. Recommended tool set: "EWP 10x10 ..."

Article No.	Tool set	Information
1301313	EWP 6x10	Recommended for plugs PBD M 6x10. (driven by hammer)
1301302	EWP 6x10 SDS	Recommended for plugs PBD M 6x10. (driven by hammer drill)
1301314	EWP 10x10	Recommended for plugs PBD M 10x10. (driven by hammer)
1301307	EWP 6x10 SDS	Recommended for plugs PBD M 6x10. (driven by hammer drill)



Plastic armoured conduit, type Kupa DN M

PRODUCT INFORMATION

APPLICATION

For laying single and multiple cables on ceilings or walls.
System Circuit Integrity is achieved for Datwyler Keram cable types
(N)HXH / (N)HXH CL / (N)HXCH FE180/E30-E60, (N)HXH / (N)HXCH FE 180/E90,
JE-H(St)H FE180/E30-E90 and JE-H(St)HRH FE 180/E30-E90.
Maximum permissible fixing distance: 800 mm.

TECHNICAL DATA

Material	Halogen-free plastic, flame retardant, resistant against corrosion
Colour	Grey, similar to RAL 7035
Approvals	DIN EN 61386-21
Classification	3 = Compressive strength medium (750N/5 cm) 3 = Impact strength medium (2kg/100 m) 4 = minimum temperature -25°C 2 = maximum temperature +90°C

Halogen-free smooth plastic tube with molded sleeve on one end, in lengths of 3 m

Article No.	Tube type	Inner ø (mm)	Outer ø (mm)	PU	Fire load (kW/h/m)
1300600	Kupa DN 16 M	13.0	16.0	111 m	0.545
1300601	Kupa DN 20 M	16.8	20.0	111 m	0.817
1300602	Kupa DN 25 M	21.5	25.0	57 m	1.090
1300603	Kupa DN 32 M	28.0	32.0	57 m	1.393
1300604	Kupa DN 40 M	35.5	40.0	21 m	2.024
1300605	Kupa DN 50 M	45.2	50.0	21 m	2.802
1300606	Kupa DN 63 M	57.8	63.0	21 m	3.542

In order to attach Datwyler's type "Kupa" plastic armoured conduits, we recommend
SAS single clamps with fire protection plugs K6x5 30 mm or
Datwyler strap clamps type B with C-shaped rail SLD and fire protection plugs KDM 30 mm.

Please also see our optional installation methods:
installation of cable bundles in clamps, installation in steel armoured conduits, etc.

PREVENTIVE FIRE PROTECTION

Plastic armoured conduits

accessories / halogen-free

DIN VDE 0604-2-100



Bend, type Kupa DN MB

Insertable sleeve, type Kupa DN MM

PRODUCT INFORMATION

Halogen-free plastic insertable sleeve

Article No.	Sleeve	PU
1300607	Kupa DN 16 MM	25 pcs.
1300608	Kupa DN 20 MM	50 pcs.
1300609	Kupa DN 25 MM	50 pcs.
1300610	Kupa DN 32 MM	25 pcs.
1300611	Kupa DN 40 MM	25 pcs.
1300612	Kupa DN 50 MM	10 pcs.
1300613	Kupa DN 63 MM	5 pcs.

Halogen-free plastic bend/conduit, 90°

Article No.	Bend	PU
1300614	Kupa DN 16 MB	25 pcs.
1300615	Kupa DN 20 MB	25 pcs.
1300616	Kupa DN 25 MB	25 pcs.
1300617	Kupa DN 32 MB	25 pcs.
1300618	Kupa DN 40 MB	25 pcs.
1300619	Kupa DN 50 MB	10 pcs.
1300620	Kupa DN 63 MB	5 pcs.

Single clamp for plastic bend/conduit, type Kupa

Article No.	Clamp type	Kupa conduit Ø (mm)	PU
1300021	SAS 16 D	DN 16	100 pcs.
1300023	SAS 20 D	DN 20	100 pcs.
1300026	SAS 26 D	DN 25	100 pcs.
1300051	SAS 38 D	DN 32	25 pcs.
1300252	SAS 47 D new	DN 40	20 pcs.
1300234	SAS 55 D new	DN 50	20 pcs.

In order to attach Datwyler's type "Kupa" plastic conduits, we recommend Datwyler SAS single clamps with fire protection plugs K6x5 30 mm or Datwyler strap clamps type B with C-shaped rail SLD and Datwyler fire protection plugs KDM 30 mm.

Please also see our optional installation methods:
installation of cable bundles in clamps, installation in steel armoured conduits, etc.



Steel armoured conduit, type Stapa DN SV

PRODUCT INFORMATION

APPLICATION For laying single and multiple cables on ceilings or walls. Suitable for indoor and outdoor use. System Circuit Integrity E30 is achieved for Datwyler Keram cable types (N)HXH / (N)HXH CL FE180/E30-E60, JE-H(St)H FE180/E30-E90 and JE-H(St)HRH FE 180/E30-E90. Maximum permissible fixing distance: 800 mm.

TECHNICAL DATA

Material	Rolled ingot steel
Colour	Hot-dip galvanised, inside and outside, in accordance with EN/ISO 1461
Approvals	DIN EN 61386-21
Classification	4 = Compressive strength heavy (1250N/5 cm) 4 = Impact strength heavy (2kg/300 m) 5 = minimum temperature - 45°C 7 = maximum temperature + 400°C

Steel armoured conduit, round, hot-dip galvanised, in lengths of 3 m

Article No.	Tube type	Inner Ø (mm)	Outer Ø (mm)	PU
1300621	Stapa DN 16 SV	13.3	16.0	30 m
1300622	Stapa DN 20 SV	17.3	20.0	30 m
1300623	Stapa DN 25 SV	22.1	25.0	30 m
1300624	Stapa DN 32 SV	29.0	32.0	21 m
3800135	Stapa DN 40 SV	37.0	40.0	15 m
1300626	Stapa DN 50 SV	47.0	50.0	15 m
1300627	Stapa DN 63 SV	59.5	63.0	15 m

Accessories: insertable sleeve, hot-dip galvanised

Article No.	Insertable sleeve	PU
1300639	Stapa DN 16 SVM	25 pcs.
1300640	Stapa DN 20 SVM	50 pcs.
1300641	Stapa DN 25 SVM	50 pcs.
1300642	Stapa DN 32 SVM	50 pcs.
1300643	Stapa DN 40 SVM	25 pcs.
1300644	Stapa DN 50 SVM	10 pcs.
1300645	Stapa DN 63 SVM	5 pcs.

In order to attach Datwyler's type "Stapa" steel armoured conduits, we recommend SAS single clamps with fire protection plugs K6x5 30 mm or Datwyler strap clamps type B with C-shaped rail SLD and fire protection plugs KDM 30 mm.

Please also see our optional installation methods:
installation of cable bundles in clamps, installation in plastic armoured conduits, etc.

Steel armoured conduits
accessories / galvanised



Galvanised steel armoured conduit:
bend, type Stapa DN SVB,
insertable sleeve, type Stapa DN SVM,
end part, type Stapa DN SVE

PRODUCT INFORMATION

Insertable bend, 90°, galvanised

Article No.	Bend	PU
1300648	Stapa DN 16 SVB	15 pcs.
1300649	Stapa DN 20 SVB	25 pcs.
1300650	Stapa DN 25 SVB	25 pcs.
1300651	Stapa DN 32 SVB	20 pcs.
1300652	Stapa DN 40 SVB	15 pcs.
1300653	Stapa DN 50 SVB	5 pcs.
1300654	Stapa DN 63 SVB	3 pcs.

End part, galvanised

Article No.	End part	PU
1300684	Stapa DN 16 SVE	25 pcs.
1300685	Stapa DN 20 SVE	50 pcs.
1300686	Stapa DN 25 SVE	50 pcs.
1300687	Stapa DN 32 SVE	50 pcs.
1300688	Stapa DN 40 SVE	25 pcs.
1300689	Stapa DN 50 SVE	10 pcs.
1300690	Stapa DN 63 SVE	5 pcs.

Halogen-free end part, full plastic

Article No.	End part	PU
1300630	Stapa DN 16 SKE	50 pcs.
1300631	Stapa DN 20 SKE	100 pcs.
1300632	Stapa DN 25 SKE	100 pcs.
1300633	Stapa DN 32 SKE	50 pcs.
1300634	Stapa DN 40 SKE	50 pcs.
1300635	Stapa DN 50 SKE	25 pcs.
1300636	Stapa DN 63 SKE	20 pcs.

Single clamp for steel armoured conduit

Article No.	Clamp type	Stapa conduit Ø (mm)	PU
1300021	SAS 16 D	DN 16	100 pcs.
1300023	SAS 20 D	DN 20	100 pcs.
1300026	SAS 26 D	DN 25	100 pcs.
1300051	SAS 38 D	DN 32	25 pcs.
1300252	SAS 47 D new	DN 40	20 pcs.
1300234	SAS 55 D new	DN 50	20 pcs.

In order to attach Datwyler's type "Stapa" steel armoured conduits, we recommend SAS single clamps with fire protection plugs K6x5 30 mm or strap clamps type B with C-shaped rail SLD and fire protection plugs KDM 30 mm.

Please also see our optional installation methods:
installation of cable bundles in clamps, installation in plastic armoured conduits, etc.



Steel armoured conduit, type Stapa DN SL

PRODUCT INFORMATION

APPLICATION For laying single and multiple cables on ceilings or walls.
 System Circuit Integrity E30 is achieved for Datwyler Keram cable types
 (N)HXH / (N)HXH CL FE180/E30-E60, JE-H(St)H FE180/E30-E90 and JE-H(St)HRH FE 180/E30-E90.
 Maximum permissible fixing distance: 800 mm.

TECHNICAL DATA

Material	Rolled ingot steel
Colour	Stove-enamel based on alkyd melamin resin, free of heavy metals, black
Approvals	DIN EN 61386-21
Classification	4 = Compressive strength heavy (1250N/5 cm) 4 = Impact strength heavy (2kg/300 m) 5 = minimum temperature - 45°C 6 = maximum temperature + 250°C

Steel armoured conduit, round, black varnished, in lengths of 3 m

Article No.	Tube type	Inner ø (mm)	Outer ø (mm)
1300657	Stapa DN 16 SL 13,3	16,0	30 m
1300658	Stapa DN 20 SL 17,3	20,0	30 m
1300659	Stapa DN 25 SL 22,1	25,0	30 m
1300660	Stapa DN 32 SL 29,0	32,0	21 m
1300661	Stapa DN 40 SL 37,0	40,0	15 m
1300662	Stapa DN 50 SL 47,0	50,0	15 m
1300663	Stapa DN 63 SL 59,9	63,0	15 m

Accessories: insertable sleeve, black varnished

Article No.	Insertable sleeve	PU
1300666	Stapa DN 16 SLM	25 pcs.
1300667	Stapa DN 20 SLM	50 pcs.
1300668	Stapa DN 25 SLM	50 pcs.
1300669	Stapa DN 32 SLM	50 pcs.
1300670	Stapa DN 40 SLM	25 pcs.
1300671	Stapa DN 50 SLM	10 pcs.
1300672	Stapa DN 63 SLM	5 pcs.

In order to attach Datwyler's type "Stapa" steel armoured conduits, we recommend
 SAS single clamps with fire protection plugs K6x5 30 mm or
 Datwyler strap clamps type B with C-shaped rail SLD and fire protection plugs KDM 30 mm.

Please also see our optional installation methods:
 installation of cable bundles in clamps, installation in plastic armoured conduits, etc.

Steel armoured conduits
accessories / black varnished



Steel armoured conduit, black varnished:
bend, type Stapa DN SLB,
insertable sleeve, type Stapa DN SLM,
end part, type Stapa DN SLE

PRODUCT INFORMATION

Insertable bend, 90°, black varnished

Article No.	Bend	PU
1300675	Stapa DN 16 SLB	15 pcs.
1300676	Stapa DN 20 SLB	25 pcs.
1300677	Stapa DN 25 SLB	25 pcs.
1300678	Stapa DN 32 SLB	20 pcs.
1300679	Stapa DN 40 SLB	15 pcs.
1300680	Stapa DN 50 SLB	5 pcs.
1300681	Stapa DN 63 SLB	3 pcs.

End part, black varnished

Article No.	End part	PU
1300693	Stapa DN 16 SLE	25 pcs.
1300694	Stapa DN 20 SLE	50 pcs.
1300695	Stapa DN 25 SLE	50 pcs.
1300696	Stapa DN 32 SLE	50 pcs.
1300697	Stapa DN 40 SLE	25 pcs.
1300698	Stapa DN 50 SLE	10 pcs.
1300699	Stapa DN 63 SLE	5 pcs.

End part, halogen-free, full plastic

Article No.	End part	PU
1300630	Stapa DN 16 SKE	50 pcs.
1300631	Stapa DN 20 SKE	100 pcs.
1300632	Stapa DN 25 SKE	100 pcs.
1300633	Stapa DN 32 SKE	50 pcs.
1300634	Stapa DN 40 SKE	50 pcs.
1300635	Stapa DN 50 SKE	25 pcs.
1300636	Stapa DN 63 SKE	20 pcs.

Single clamp for steel armoured conduit

Article No.	Clamp type	Stapa conduit Ø (mm)	PU
1300021	SAS 16 D	DN 16	100 pcs.
1300023	SAS 20 D	DN 20	100 pcs.
1300026	SAS 26 D	DN 25	100 pcs.
1300051	SAS 38 D	DN 32	25 pcs.
1300252	SAS 47 D new	DN 40	20 pcs.
1300234	SAS 55 D new	DN 50	20 pcs.

In order to attach Datwyler´s type "Stapa" steel armoured conduits, we recommend SAS single clamps with fire protection plugs K6x5 30 mm or strap clamps type B with C-shaped rail SLD and fire protection plugs KDM 30 mm.

Please also see our optional installation methods:
installation of cable bundles in clamps, installation in plastic armoured conduits, etc.

Colour codes in accordance with VDE, CENELEC and SEV standards

CORE COLOURS in accordance with DIN VDE 0293 - 308 : 01/2003 (CENELEC HD 308 10/2001)

No. of cores	1(-O)		1(-J)	2(-O)		2(-J)	3(-O)		3(-J)	3 ^a (-O)		4(-O)	4(-J)	4 ^a (-J)		5(-O)	5(-J)
	L	N	PE	LN	LPE	3L	LNPE	2LN	3LN	3LPE	2LNPE	4LN	3LNPE	4LN	3LNPE	4LN	3LNPE
Yellow-green (PE)																	
Blue (N)																	
Brown (L)																	
Black (L)																	
Grey (L)																	

L = Phase conductor Colour code for cables ≥ 6 cores (^a only for certain applications)
 N = Neutral conductor Phase conductor = Black with white number printing
 PE = Protective conductor Protective conductor = Green-yellow

CABLE PRINTING

In order to guarantee the identification and traceability, the production batch is printed on all Datwyler cables. The meter marks simply the cable handling. The diameter (mm²) facilitates the identification of cables.

Printing example DATWYLER KERAM FE180 «N x MM²» SWISS MADE «PRODUCTION BATCH» «METER MARKS»

CORE COLOURS in accordance with VDE 0815 for fire alarm cables JE-H(ST)H...Bd

- Two pairs
 Pair 1: a-core blue, b-core red
 Pair 2: a-core grey, b-core yellow
 Remark: Only a two-pair cable is a Quad
- Three pairs and more
 Pair 1: a-core blue, b-core red
 Pair 2: a-core grey, b-core yellow
 Pair 3: a-core green, b-core brown
 Pair 4: a-core white, b-core black

Pair	Core a	Core b
1		
2		
3		
4		

Ring group 1 Each bundle is part of a ring group.
 Ring group 2 All cores of a bundle are identified by the ring colour
 Ring group 3 or by a plastic helix with printed numbers. Counting to
 Ring group 4 be started at inside layer.

Identification of bundles

Bundle no.	1	2	3	4	5	6	7	8	9	10	11	12	13	14	15	16	17	18	19	20
Ring colour																				
Ring group consists of	4 cores																			
	8 cores resp. 4 pairs				IV				IV				IV				IV			
Helix																				

CORE COLOURS OF WIRING CABLES J-H(ST)H...BD

Basic colours of insulation of the 5 star quads of a bundle

- Quad: Basic colour of all cores red
- Quad: Basic colour of all cores green
- Quad: Basic colour of all cores grey
- Quad: Basic colour of all cores yellow
- Quad: Basic colour of all cores white

The cores of a quad are identified by rings

Circuit 1 **a-Core** The bundle where counting starts is identified by a red plastic tape.
Circuit 2 **b-Core** Remaining bundles are identified by white or neutral tapes.

E30-E90 support systems

Preventive fire protection and enhanced circuit integrity

The co-ordinated and licensed Datwyler products enable optimal system approaches and guarantee highest quality, cost-efficiency, saving of time and security.



300 mm

Standard laying technics with single clamp (of different manufacturers)



600 mm

Standard laying technics with strap clamp with trough (of different manufacturers)



600 / 800 mm

Hermann clamp: bundling e.g. 30 cables 3x1,5mm²



600 / 800 / 1200 mm

Single clamp: bundling up to 2,5 kg/m
Strap clamp: bundling up to 2,5 kg/m

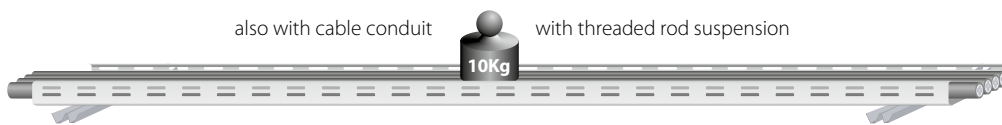

1200 mm

Standard cable tray (of different manufactures)



1500 mm

Datwyler cable tray without threaded rod suspension
for wall and ceiling installation.
Optional laying techniques with different cable tray manufacturers.

Datwyler E30-E90 Support systems

IEC	International Electrotechnical Commission
IEC 60228	Conductors of insulated cables
IEC 60331-1	Tests for electric cables under fire conditions - Circuit integrity - Part 1: Test method for fire with shock at a temperature of at least 830 °C for cables of rated voltage up to and including 0,6/1,0 kV and with an overall diameter exceeding 20 mm
IEC 60331-11	Tests for electric cables under fire conditions - Circuit integrity - Part 11: Apparatus - Fire alone at a flame temperature of at least 750 °C
IEC 60331-2	Tests for electric cables under fire conditions - Circuit integrity - Part 2: Test method for fire with shock at a temperature of at least 830 °C for cables of rated voltage up to and including 0,6/1,0 kV and with an overall diameter not exceeding 20 mm
IEC 60331-21	Tests for electric cables under fire conditions - Circuit integrity - Part 21: Procedures and requirements - Cables of rated voltage up to and including 0,6/1,0 kV
IEC 60331-23	Tests for electric cables under fire conditions - Circuit integrity - Part 23: Procedures and requirements - Electric data cables
IEC 60331-25	Tests for electric cables under fire conditions - Circuit integrity - Part 25: Procedures and requirements - Optical fibre cables
IEC 60332-1-1	Test on electric and optical fibre cables under fire conditions. Part 1-1 Test for vertical flame propagation for a single insulated wire or cable - Apparatus
IEC 60332-1-2	Test on electric and optical fibre cables under fire conditions. Part 1-2 Test for vertical flame propagation for a single insulated wire or cable – Procedure for 1 kW pre-mixed flame
IEC 60332-3-10	Tests on electric cables under fire conditions - Part 3-10: Test for vertical flame spread of vertically-mounted bunched wires or cables - Apparatus
IEC 60332-3-22	Tests on electric and optical fibre cables under fire conditions – Part 3-22: Test for vertical flame spread of vertically-mounted bunched wires or cables – Category A
IEC 60332-3-23	Tests on electric and optical fibre cables under fire conditions - Part 3-23: Test for vertical flame spread of vertically-mounted bunched wires or cables - Category B
IEC 60332-3-24	Tests on electric and optical fibre cables under fire conditions - Part 3-24: Test for vertical flame spread of vertically-mounted bunched wires or cables - Category C
IEC 60332-3-25	Tests on electric and optical fibre cables under fire conditions - Part 3-25: Test for vertical flame spread of vertically-mounted bunched wires or cables - Category D
IEC 60754-1	Test on gases evolved during combustion of materials from cables - Part 1: Determination of the amount of halogen acid gas
IEC 60754-2	Test on gases evolved during combustion of electric cables - Part 2: Determination of degree of acidity of gases evolved during the combustion of materials taken from electric cables by measuring pH and conductivity
IEC 60794-1-2	Optical fibre cables - Part 1-2: Generic specification - Basic optical cable test procedures
IEC 61034-1	Measurement of smoke density of cables burning under defined conditions - Part 1: Test apparatus
IEC 61034-2	Measurement of smoke density of cables burning under defined conditions - Part 2: Test procedure and requirements

Safety cables
Support systems
Fixing devices
Distribution boxes
Accessories
Information

EN	European Standard
EN 50200	Method of test for resistance to fire of unprotected small cables for use in emergency circuits
EN 50267-1	Common test methods for cables under fire conditions. Tests on gases evolved during combustion of materials from cables. Part 1: Apparatus
EN 50267-2-1	Common test methods for cables under fire conditions. Tests on gases evolved during combustion of materials from cables. Part 2-1: Procedures - Determination of the amount of halogen acid gas
EN 50267-2-2	Common Test Methods for Cables Under Fire Conditions. Tests on gases evolved during combustion of materials from cables. Part 2-2: Procedures - Determination of degree of acidity of gases for materials by measuring pH and conductivity
EN 50267-2-3	Common test methods for cables under fire conditions. Tests on gases evolved during combustion of materials from cables. Part 2-3: Procedures - Determination of degree of acidity of gases for cables by determination of the weighted average of pH and conductivity
EN 50362	Method of test for resistance to fire of larger unprotected power and control cables for use in emergency circuits
EN 50363-5	Insulating, sheathing and covering materials for low voltage energy cables - Part 5: Halogen-free, cross-linked insulating compounds
EN 60228	Conductors of insulated cables
EN 60332-1-1	Tests on electric and optical fibre cables under fire conditions - Part 1-1: Test for vertical flame propagation for a single insulated wire or cable - Apparatus
EN 60332-1-2	Tests on electric and optical fibre cables under fire conditions - Part 1-2: Test for vertical flame propagation for a single insulated wire or cable - Procedure for 1 kW pre-mixed flame
EN 61034-1	Measurement of smoke density of cables burning under defined conditions. Test apparatus
EN 61034-2	Measurement of smoke density of cables burning under defined conditions. Test procedure and requirements
VDE	Association for Electro-Technics, Electronics & Information Technologies
VDE 0472-814	Testing of cables, wires and flexible cords; continuance of isolation effect under fire conditions
VDE 0482-200	Method of test for resistance to fire of unprotected small cables for use in emergency circuits
VDE 0482-267-1	Common test methods for cables under fire conditions - Tests on gases evolved during combustion of materials from cables - Part 1: Apparatus
VDE 0482-267-2-1	Common test methods for cables under fire conditions - Tests on gases evolved during combustion of material from cables - Part 2-1: Procedures; determination of the amount of halogen acid gas; German version EN 50267-2-1:1998
VDE 0482-267-2-2	Common test methods for cables under fire conditions - Tests on gases evolved during combustion of material from cables - Part 2-2: Procedures; determination of degree of acidity of gases for materials by measuring pH and conductivity
VDE 0482-267-2-3	Common test methods for cables under fire conditions - Tests on gases evolved during combustion of material from cables - Part 2-3: Procedures; determination of degree of acidity of gases for cables by determination of the weighted average of pH and conductivity
VDE 0482-332-1-1	Test on electric and optical fibre cables under fire conditions. Part 1-1 Test for vertical flame propagation for a single insulated wire or cable - Apparatus
VDE 0482-332-1-2	Test on electric and optical fibre cables under fire conditions. Part 1-2 Test for vertical flame propagation for a single insulated wire or cable - Procedure for 1 kW pre-mixed flame
VDE 0482-362	Method of test for resistance to fire of larger unprotected power and control cables for use in emergency circuits
VDE 0482-1034-1	Measurement of smoke density of cables burning under defined conditions - Part 1: Test apparatus
VDE 0482-1034-2	Measurement of smoke density of cables burning under defined conditions - Part 2: Test procedure and requirements





DIN	German Institute for Standardization
DIN 4102-12	Fire behaviour of building materials and building components - Part 12: Circuit integrity maintenance of electric cable systems; requirements and testing
BS	British Standard
BS 5839-1+A2	Fire detection and fire alarm systems for buildings. Code of practice for system design, installation, commissioning and maintenance
BS 6387	Specification for performance requirements for cables required to maintain circuit integrity under fire conditions
BS 7629-1	Electric cables. Specification for 300/500 V fire resistant screened cables having low emission of smoke and corrosive gases when affected by fire. Multicore and multipair cables
BS 7655-0	Specification for insulating and sheathing materials for cables. General introduction
BS EN 60228	Conductors of insulated cables
BS 8434-2 +A2	Test for unprotected small cable for use in emergency circuits BS EN 50200 with a 930°C flame and with water spray
VdS	Inspected. Approved. Safe.
VdS 3423	E90 cable for water extinguishing system with additional circuit integrity against water penetration, requirements and test methods (draft)
NBN	Belgian Standard
NBN 713-020	Fire fighting - Fire performance of building materials and products - Fire resistance of building materials

LOCATIONS

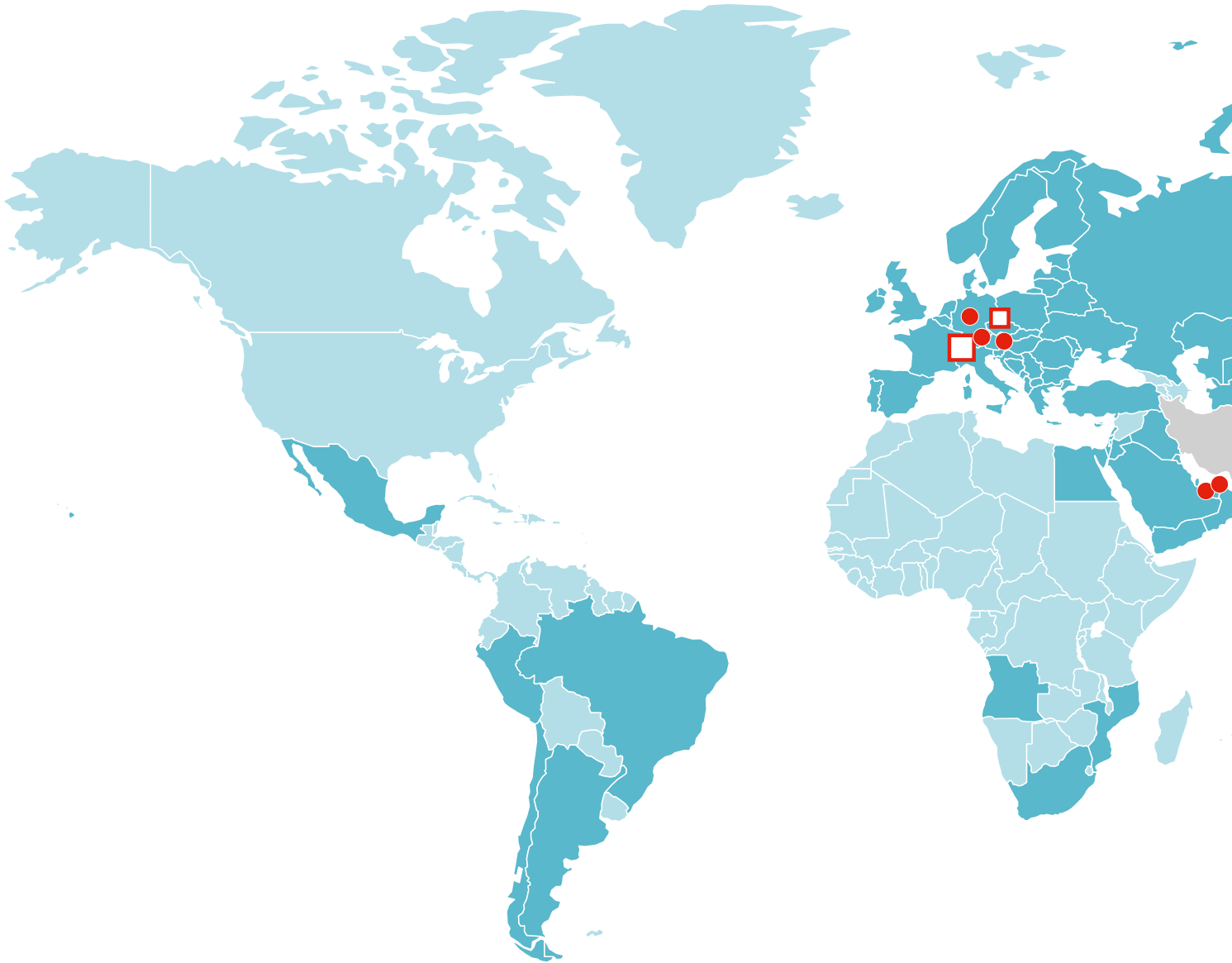
Offices and distribution partners

GLOBAL MARKET COMPETENCE



-  Datwyler Headquarters and Manufacturing Plant
-  Datwyler Manufacturing Plants
-  Datwyler Offices
-  Active Market Presence by Datwyler and its Distribution Partners

Are you searching for a distribution partner in our export markets?
Please visit www.cabling.datwyler.com for details of our partners
or contact our relevant branches.



**SWITZERLAND / GREAT BRITAIN /
SOUTHERN EUROPE / LATIN AMERICA**

Dätwyler Cabling Solutions AG
Gotthardstrasse 31, 6460 Altdorf / Switzerland
T +41 41 875-1268, F +41 41 875-1986
info.cabling.ch@datwyler.com

GERMANY / BENELUX / NORTH & EASTERN EUROPE

Dätwyler Cables GmbH
Auf der Roos 4-12, 65795 Hattersheim / Germany
T +49 6190 8880-0, F +49 6190 8880-80
info.cabling.de@datwyler.com

AUSTRIA / HUNGARY

Dätwyler Cables GmbH, Office Austria
Tenschertstraße 8, 1230 Wien / Austria
T +43 1 8101641-0, F +43 1 8101641-35
info.cabling.at@datwyler.com

ASIA / OCEANIA

Datwyler (Thelma) Cables+Systems Pte Ltd
29 Tech Park Crescent
638103 Singapore
T +65 68631 166, F +65 68978885
info.cabling.sg@datwyler.com

Datwyler (Shanghai) Cables+Systems Co. Ltd
Building 16, No. 111, Kang Qiao Dong Road
Kang Qiao Industrial Zone, Pudong
201319 Shanghai / P. R. China
T +86 21 6813-0066, F +86 21 6813-0298
info.cabling.cn@datwyler.com

MIDDLE EAST

Datwyler Middle East FZE
P.O.Box 263480
Office No. 601, 6th Floor
Jafza 19 View, Jebel Ali Free Zone
Dubai / United Arab Emirates
T +971 4 8810239, F +971 4 8810238
info.cabling.ae@datwyler.com

Datwyler Cabling Solutions LLC
Unit 1004 & 1005, 10th Floor,
IB Tower, Business Bay
Dubai / United Arab Emirates
T +971 4 4228129, F +971 4 4228096
info.cabling.ae@datwyler.com



DATWYLER

SWITZERLAND

Dätwyler Cabling Solutions AG

Gotthardstrasse 31
6460 Altdorf
T + 41 41 875-1268
F + 41 41 875-1986
info.cabling.ch@datwyler.com
www.cabling.datwyler.com

GERMANY

Dätwyler Cables GmbH

Auf der Roos 4-12
65795 Hattersheim
T + 49 6190 8880-0
F + 49 6190 8880-80
info.cabling.de@datwyler.com
www.cabling.datwyler.com

Dätwyler Cables GmbH

Lilienthalstraße 17
85399 Hallbergmoos
T + 49 811 998633-0
F + 49 811 998633-30
info.cabling.de@datwyler.com
www.cabling.datwyler.com

AUSTRIA

Dätwyler Cables GmbH

Office Austria
Tenschertstraße 8
1230 Wien
T + 43 1 8101641-0
F + 43 1 8101641-35
info.cabling.at@datwyler.com
www.cabling.datwyler.com

UNITED ARAB EMIRATES

Datwyler Middle East FZE

P.O.Box 263480
Office No. 601, 6th Floor, Jafza 19 View
Jebel Ali Free Zone
Dubai
T +971 4 8810239
F +971 4 8810238
info.cabling.ae@datwyler.com
www.cabling.datwyler.com

Datwyler Cabling Solutions LLC

Unit 1004 & 1005, 10th Floor, IB Tower
Business Bay
Dubai
T +971 4 4228129
F +971 4 4228096
info.cabling.ae@datwyler.com
www.cabling.datwyler.com

CHINA

Datwyler Cables+Systems

(Shanghai) Co. Ltd
Building 16, No. 111,
Kang Qiao Dong Road
Kang Qiao Industrial Zone, Pudong
Shanghai, 201319
T + 86 21 6813-0066
F + 86 21 6813-0298
info.cabling.cn@datwyler.com
www.cabling.datwyler.com

Datwyler (Suzhou)

Cabling Systems Co. Ltd
Block 31, 15# Dong Fu Road
Suzhou Singapore Industrial Park
Suzhou, 215123
T + 86 512 6265-3600
F + 86 512 6265-3650
harnessing.cabling.cn@datwyler.com
www.cabling.datwyler.com

SINGAPORE

Datwyler (Thelma)

Cables+Systems Pte Ltd
29 Tech Park Crescent
638103 Singapore
T + 65 68631166
F + 65 68978885
info.cabling.sg@datwyler.com
www.cabling.datwyler.com