

DL SERIES PLUG*

The Lee Company's new DL Series Plug is the latest addition to our plug product lines. The DL Series Plug is a single-piece, stainless steel plug engineered to provide leak-tight performance in aluminum housings without the use of threads, sealants, or O-rings.

The DL Series Plug utilizes our new Drive Locking™ technology to reliably seal passages for life. This new locking end includes an Installation Indicator™ feature that allows customers to visually verify that the DL Series Plug was properly installed. The Installation Indicator feature provides additional information for critical assembly processes and enables manufacturers to automate both the installation and the verification process. Overall, the DL Series Plug helps our customers to reduce scrap and labor costs while improving reliability.

Thanks to its compact size, competitive price point, and easy-to-automate installation process, the DL Series Plug meets the demands of the automotive, industrial, and medical industries. The shallow body of the plug provides several benefits for designers, including saved space, reduced manifold size and weight, and minimized dead volume. The DL Series Plug is ideally suited for high volume applications where performance, quality, and reliability are critical to success.

- Reliable performance
 - Rated for pressures up to 69 Bar (1000 psi) in aluminum
- One-piece assembly
 - Facilitates reliable automated or manual installation
 - Installation Indicator feature enables visual verification of proper installation
- Drive Locking technology creates a permanent seal without threads, sealants, or O-rings

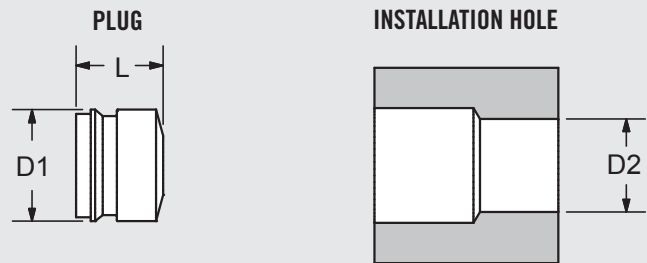

DL SERIES PLUG SPECIFICATIONS				
PART NUMBER	PLUG DIAMETER (D1)	MAXIMUM SEALABLE PASSAGEWAY (D2)	PLUG LENGTH (L)	RATED PRESSURE **
DLPM0410100S	3.91 - 3.99	3.30	3.00	69 Bar (1000 psi)
DLPM0510100S	4.91 - 4.99	4.30	3.00	69 Bar (1000 psi)
DLPM0610100S	5.91 - 5.99	5.30	3.00	69 Bar (1000 psi)
DLPM0710100S	6.91 - 6.99	6.30	3.00	69 Bar (1000 psi)
DLPM0810100S	7.91 - 7.99	7.30	3.00	69 Bar (1000 psi)

VISUALLY VERIFY INSTALLATION

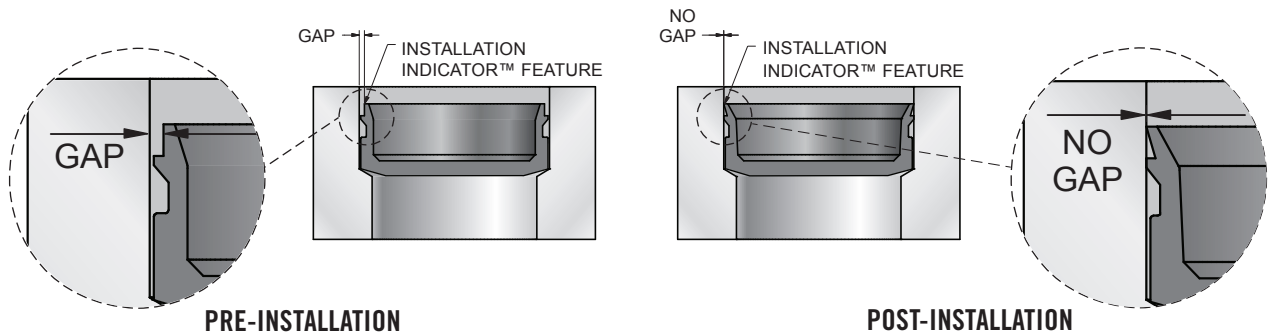

* Patent Pending

** Rated pressure in 6061 Aluminum. Rated pressures may be higher depending on specific application requirements. Contact your local Lee Sales Engineer for higher pressure or different housing material requirements.

All dimensions are in millimeters, except where noted.



DL SERIES PLUG

INSTALLATION HOLE

The DL Series Plug is designed to perform well under adverse conditions. Therefore, the installation hole specifications outlined below should be followed precisely to ensure that the plug will achieve a proper seal. Installation forces and pressure ratings are based on installation in aluminum housings or manifolds.

The installation hole should be clean, dry, and free of burrs. The surface finish should not exceed 1.6 μm (Ra) with no longitudinal surface defects. These surface finish requirements must be given special attention as a smooth machined surface is needed to seal and retain the plug properly.

The Lee Company does not recommend the use of coatings or surface treatments in the hole where the product is to be installed. These treatments may reduce the plug's retention and performance.

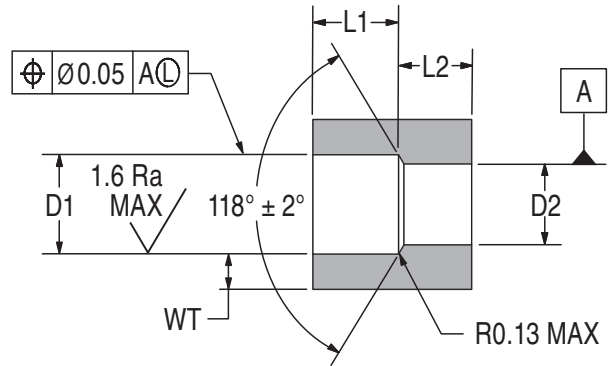

All dimensions are in millimeters.

DL SERIES PLUG INSTALLATION HOLE DIMENSIONS (mm)

PLUG SIZE	MAJOR ID (D1)	MAX SEALABLE PASSAGWAY (D2)	MIN HOLE DEPTH (L1)	MINIMUM THROUGH HOLE DEPTH (L2)	MINIMUM WALL THICKNESS (WT)
4	4.00 - 4.10	3.30	3.50	3.00	1.44
5	5.00 - 5.10	4.30	3.50	3.00	1.78
6	6.00 - 6.10	5.30	3.50	3.00	2.14
7	7.00 - 7.10	6.30	3.50	3.00	2.48
8	8.00 - 8.10	7.30	3.50	3.00	2.84

DL SERIES PLUG INSTALLATION

The DL Series Plug utilizes our Drive Locking technology with an Installation Indicator verification feature. To properly install the part, place it in the recommended installation hole, Drive Locking feature facing up, and then apply a non-impact force using the recommended installation tool until the Installation Indicator feature is in contact with the housing wall 360° around the part. When no gap is visible between the Installation Indicator feature and housing wall, the part is fully installed.

The plug is designed to be installed using an electric servo press system. Pneumatic or hydraulic systems may also be used. The housing in which the component is to be installed should be held stationary on a solid surface.

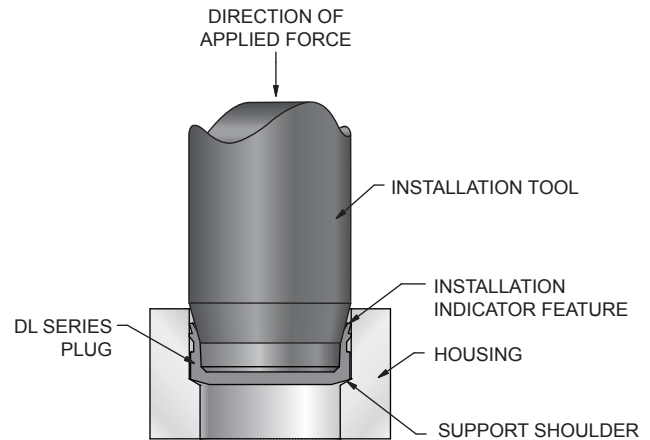

DL SERIES PLUG INSTALLATION SPECIFICATIONS		
PLUG SIZE (mm)	TYPICAL INSTALLATION FORCE (kN)	INSTALLATION TOOL PART NUMBER
4	5 - 6	CCRT0400360S
5	5 - 6	CCRT0500360S
6	5 - 6	CCRT0600360S
7	5 - 6	CCRT0700360S
8	5 - 6	CCRT0800360S

