

**INSTALLATION AND SERVICING INSTRUCTIONS FOR THE
STRAXGAS 16" ECOTECH VICTORIAN WITH CONVECTOR BOX
& SURROUND, OR SURROUND ONLY DECORATIVE
FUEL EFFECT GAS FIRE**
(To be left with the appliance)

Appliance Data:

Model	Victorian with 16" Ecotech burner	
Type of Gas	Natural gas (G20) Cat. I _{2H}	Propane gas (G31) Cat. I _{3P}
Injector size	7 x 0.80mm multihole	7 x 0.53mm multihole
Gross heat input (High setting)	6.9 kW (23,500Btu/h)	6.9kW (23,500Btu/h)
Gross heat input (Low setting)	4.4kW (15,000Btu/h)	3.5kW (12,000Btu/h)
Supply pressure	20mbar (8in.w.g.)	37mbar (14.8in.w.g.)
Appliance test point pressure (cold)	19.0mbar (±1.0mbar)	36.5mbar
Minimum flue diameter	175mm (7in.)	175mm (7in.)
Minimum effective height of chimney	3m (10ft.)	3m (10ft.)
Ignition	Piezo	Piezo
Spark gap	3.0mm min., 4.5mm max.	3.0mm min., 4.5mm max.
Dimensions	To fit into a standard 16" chairbrick	To fit a standard 16" chairbrick
Shipping weight	13kg	13kg
Country of destination	United Kingdom and Republic of Ireland	

This appliance has been assessed by a Government appointed Notified Body and shown to meet the 'Essential Requirements' of the European Gas Appliance Directive.

The Directive lays down requirements for the safety of the appliance, together with its design, construction, and use of materials. It also requires the production process to be covered by an approved and monitored system of quality assurance.

Mandatory requirements

Straxgas fires must be installed with due regard to the following **mandatory** regulations:

The relevant British Standard installation specifications and codes of practice, and Building Regulations issued by the Department of the Environment, and Building Standards (Scotland) Consolidated Regulations issued by the Scottish Development Board.

Gas Safety (Installation and Use) Regulations.

Failure to install this appliance correctly could lead to prosecution and render the guarantee invalid.

Attention is drawn to the latest issue of the following standards:

BS1251, Specifications of open fireplace components.

BS5440, Part 1, Specification for installation of flues.

BS5440, Part 2, Specification for installation of ventilation for gas appliances.

BS5482, Part 2, LPG, installations in permanent dwellings.

BS5871, Part 3, Installation of decorative fuel effect gas appliances.

BS6891, Specification of low pressure gas pipework

BS8303, Replacing CP403.

This Straxgas appliance is intended for decorative purposes and must only be installed by a competent person (e.g. a C.O.R.G.I. member) in accordance with these installation instructions.

This appliance must be installed in accordance with the rules in force, and used only in a sufficiently ventilated space. Consult these instructions before installation and use of this appliance.

GB Additional purpose made air ventilation is not normally required.

IE & Northern Ireland Ventilation must be provided in accordance with the rules in force.

Before installation

Ensure that the local distribution conditions (identification of the type of gas and pressure) and the adjustment of the appliance are compatible. Refer to the burner data badge plate.

Inspect the chimney

Ensure that:

- It only serves one fireplace
- Any terminal or cowl fitted is approved for use with this type of appliance.
- It is clear of any obstruction, and any damper or register is removed or fixed permanently in the fully open position.
- Any chimney used for an appliance burning a fuel other than gas must be thoroughly swept before installing any gas appliances.
- With an L.P.G. fire, any air supply entering the fireplace below floor level is completely sealed off.
- The chimney is properly sealed so that the combustion products do not come into contact with combustible materials outside the chimney.
- The base of the chimney is clear of loose debris, bricking up, etc.

Broken hearth components should be replaced or repaired as necessary. Refer to the appliance data for minimum chimney height and flue diameter. Check with a smoke match that there is a positive updraught present in the chimney. Examine the general condition of the chimney brickwork for evidence of deterioration; do not carry out an installation to a chimney in a poor condition. If there is a history of downdraught problems examine the possibility of fitting a British Gas approved flue terminal or cowl. Always carry out a spillage test in accordance with BS 5440 Pt. 1.

Clearances

If a shelf is to be fitted above the fire, perhaps as part of a surround, it must be positioned a minimum of 1m (39in.) above the top of the hearth, and project no more than 200mm (8in.) from the front plane of the opening. Combustible material such as wood may be fitted to within 100mm (4in.) of either side of the opening so long as it projects no more than 100mm (4in.) from the front plane of the opening.

Soft furnishings, decorations and some wall coverings may discolour or scorch if positioned too close to the fire.

Installation

Installing the convector box

Before commencing installation check:

1. The building opening sizes for installing the convector box are 855mm high x 760mm wide x 360mm deep (See Fig. 2a). The depth includes a 50mm cavity for debris collection and will allow a flush fitting installation. If this cannot be obtained the convector box can be fitted to an 80mm deep rebated surround. The builder's opening for this version is 840mm high x 450mm wide x 280mm deep (including the 50mm debris cavity).
2. To avoid damage to the factory seal the convector box must not be unbolted from the cast inset.
3. The debris deflector plate above the flue outlet must be at least 50mm clear of any surrounding brickwork.
4. A suitable hearth must be used. (See 'Hearth fitting').
5. Check that the chosen surround has a suitable rebate; 10-15mm is recommended for flush fitting and 80mm for situations where the opening may not be deep enough for normal installations. Note that a 50mm debris gap is required behind the appliance.
6. Complete all necessary pipework using a 15mm dia. min. (10mm for propane) gas supply pipe with isolation cock prior to final installation of the convector unit. The pipe must be sleeved when passing through masonry. The 8mm pipe should be brought from the isolation cock through a hole in the rear of the convector box to the burner. (See 'Gas connection')

When the convector unit is in position the casting should be drilled in 5 places (two each side and one in the centre of the top). An effective seal must be established against the chimneybreast. Fasten the convector unit to the wall using countersunk screws into suitable plastic wall plugs taking care not to overtighten the screws.

Finally, check that the casting is fully sealed against the chimneybreast before offering up the surround and fitting in accordance with the manufacturer's instructions.

Position 5 tiles each side, securing in place with fire cement or a suitable mastic sealant.

Installing the burner

The burner fits into a standard 16in. chairbrick of the dimensions shown in Fig.1 or convector box and surround assembly described above with dimensions as shown in Figs. 2 and 2a.

Hearth fitting

The Straxgas burner must be installed on a level non-combustible hearth in accordance with BS5871, Part 3. See also approved document J 1/2/3 "Heat Producing Appliances" issued by the Department of the Environment.

The hearth should project a minimum of 150mm (6in.) either side of the fireplace opening, and a minimum of 300mm (12in.) forward of the plane of the opening, and be a minimum of 50mm (2in.) above floor level.

Items supplied

The following items will be found within the carton:

1. Burner complete with controls.
2. 3 shaped ceramic fibre blocks.
3. Coals. (14 large, 6 small)
4. 2 screws with plastic plugs.
5. These installation instructions, guarantee card and End User operating instructions.

Warning: Only Straxgas approved ceramic blocks and coals, designed for this appliance, must be used with this burner. Use of ceramic components from any other supplier will invalidate the guarantee and may be dangerous.

Gas connection

Note: Gas connection is by concealed connection only. A 15mm (10mm for propane) gas supply pipe with isolation cock should be brought to within 1M of the fireplace opening. The connection to the burner can be made from the right or left-hand side by a concealed pipe from behind the burner to the elbow on the left-hand side of the burner. 8mm pipe is required for this purpose.

Location

The Straxgas burner should be located as shown in Fig.3. Locate the burner centrally in the opening.

Securely anchor the burner in the correct position using the screws and plastic plugs supplied; holes are provided in the front feet of the burner for this purpose.

Assembly

1. Connect the gas supply to the inlet elbow.
2. The ceramic components are fragile and should be handled with care. Refer to Figs. 4 and 5 for positioning of ceramic fibre blocks and coals.
3. Place the chair shaped ceramic block on the burner, pushing it back against the upturned edge of the burner plate.
4. Place the medium sized ceramic block on the chair shaped block pushing it back to sit comfortably between the sides of the first block.
5. Spring forward the slotted front plate and slide the front ceramic down as far as far as the stops.
6. Remove the coals from the bag; note that there are 2 sizes supplied with the burner. Place them on the ceramic blocks in accordance with Fig. 5.

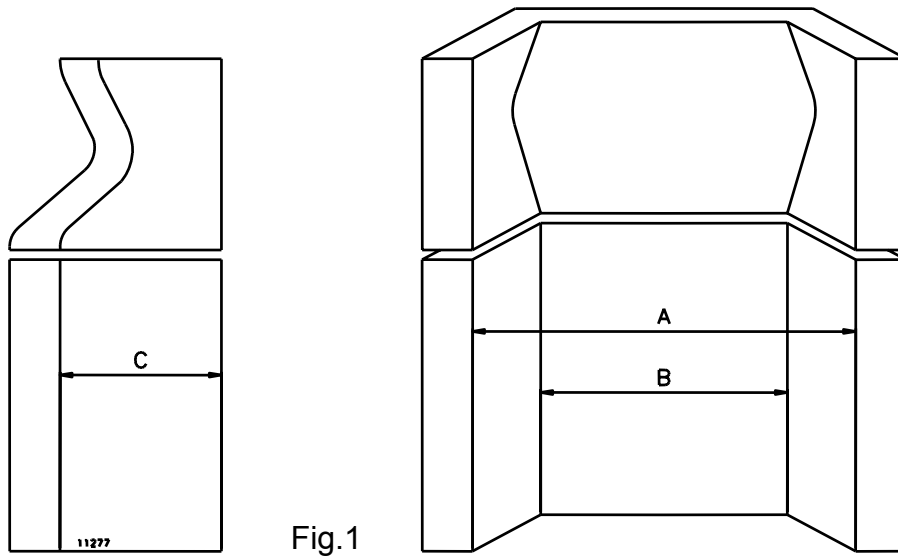

Fig.1

Nominal dimensions

Width of opening	A	380mm (15in.)
Width at rear	B	250mm (10in.)
Depth	C	170mm (7in.)

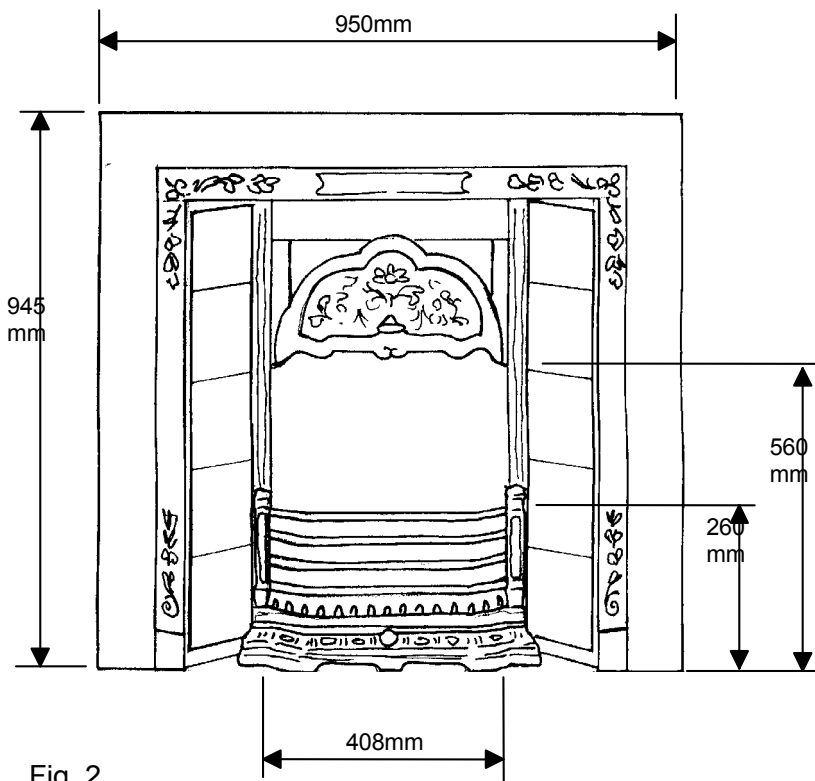

Fig. 2

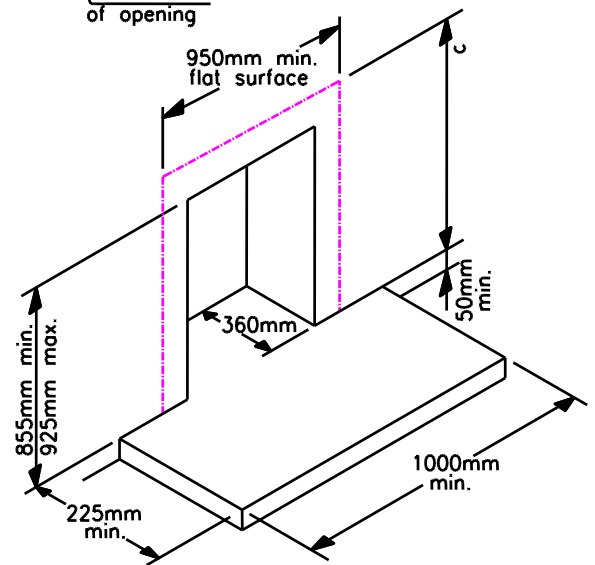
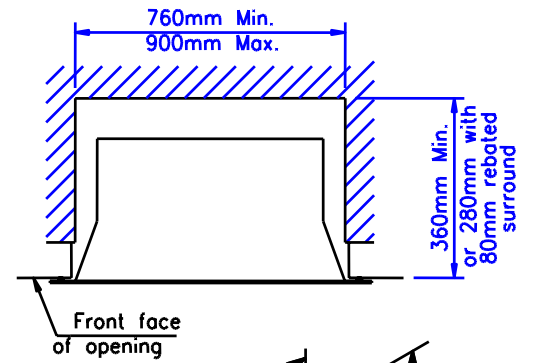

Fig. 2a Installation of surround & convector box into a masonry chimney without chairbrick

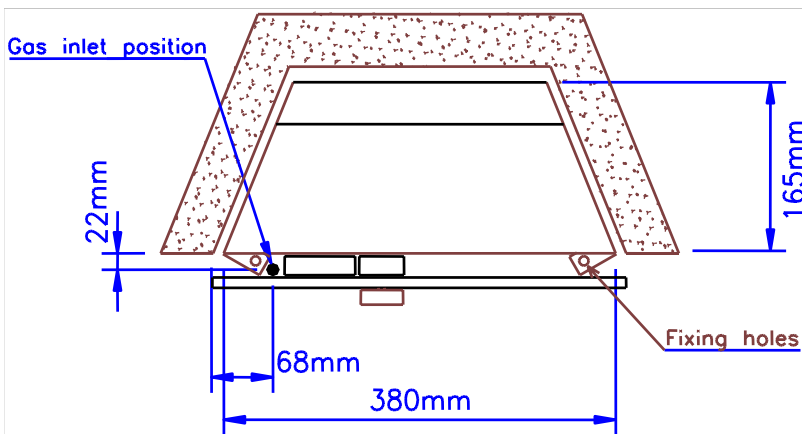

Fig. 3

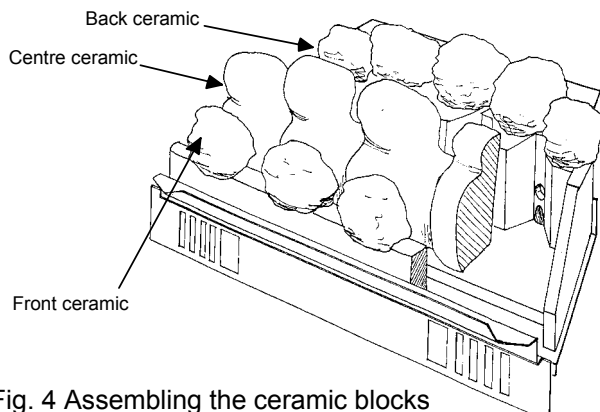

Fig. 4 Assembling the ceramic blocks

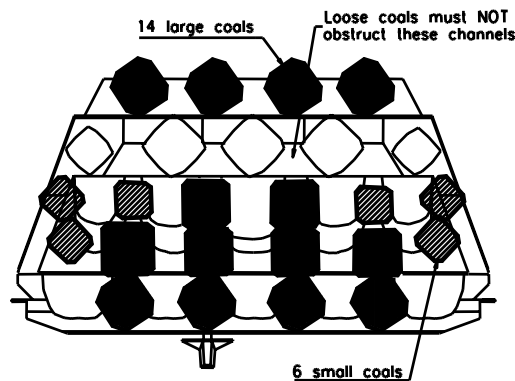

Fig. 5 Placing the loose coals

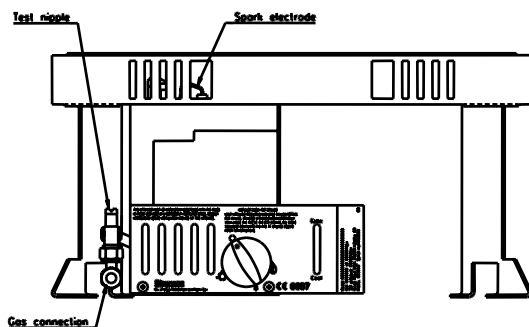
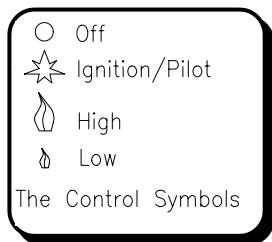

Fig. 6 The data badge plate & test nipple (natural gas version)

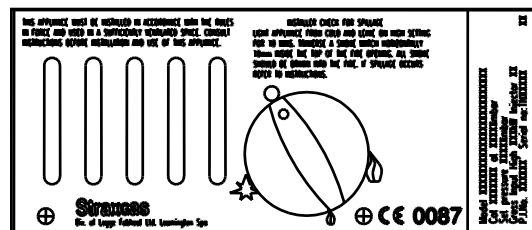

Fig. 7 Data badge plate (propane version)

Leak test & pressure test

1. Turn on the main gas supply and check for gas soundness.
2. Remove pressure test screw, and fit pressure gauge to pressure test point.
3. Light the fire (see next section).
4. Turn control knob anticlockwise to **High** position.
5. When the control knob is in the **High** position, you should have a gas pressure of 19.0mbar \pm 1.0mbar when using natural gas and 36.5mbar for propane.
6. Extinguish the fire by turning the control knob clockwise to the **Off** position.
7. Remove the pressure gauge and replace the pressure test screw. Check again for gas soundness.
8. Fit the front fret by hooking over the support lugs provided on the surround casting.

Lighting the fire

The appliance Data Badge is positioned in front of the burner behind the fret and carries the control knob positions (Fig. 6 or 7, depending on version). The full lighting procedure is as follows:

1. Push control knob in as far as possible on gas control.
2. Turn knob anticlockwise until a click is heard. The knob will stop at the ignition position and a spark should be seen at the tip of the ignition probe. At the same time the pilot flame should light. **KEEP THE KNOB PRESSED IN FOR 10 SECONDS.** If the pilot should fail to light, turn the control knob clockwise to the 'off' position, wait 3 minutes and repeat the procedure.
3. When the pilot flame is alight the control knob should be allowed to spring out slightly. Turn the knob fully anticlockwise to the high position. The pilot flame will then ignite the main fire.
4. The height of the flames can be adjusted by turning the control knob between the low and high positions. Note that the knob 'latches' in position at either end of this movement and must be pushed in slightly before it can be turned.
5. With a natural gas burner the appearance of the flames can be altered by means of the air adjustment lever positioned to the right of the control knob. Moving the lever up will admit more air and produce a 'coke fire' effect. Moving it down will close off some of the air and simulate a 'coal fire' with flickering flames.
6. To turn the fire off, depress the knob slightly and turn it to the pilot position.
7. To completely extinguish the fire depress the knob slightly and turn to the 'Off' position.

Check for clearance of products of combustion

1. Light the fire.
2. Close all windows and doors.
3. After 10 minutes traverse a smoke match across the perimeter of the opening and ensure that the smoke is drawn into the flue aperture. If spillage is detected introduce ventilation into the room by opening a window or door. If spillage is no longer detected then purpose made ventilation with a minimum area of 100 sq.cm must be provided. If after introducing ventilation into the room spillage is still detected the cause must be discovered and the fault corrected. If the fault cannot be corrected, disconnect the gas supply to the appliance and seek expert advice. Possible causes of spillage are chimney restrictions, or an incorrect cowl or terminal.
4. If there is an extraction fan in a nearby room then the spillage test must be repeated with the fan turned on and any interconnecting doors between the fire and the fan location left open.

Instruct the user

1. Hand over these Installation Instructions and the User Instructions to the person who is going to use the fire and explain how to light and operate the appliance. Explain how the fire may be lit, if necessary, by means of a long spill or taper.
2. Make certain that the user is aware that the ceramic blocks and coals must be located in accordance with the instructions, and that the appliance should be serviced at regular intervals by a competent person to ensure continued safe operation.
3. Explain that this appliance is fitted with an oxygen depletion sensor incorporated into the pilot body. Should the fire repeatedly extinguish itself, the cause should be sought and remedied as this may indicate spillage into the room of combustion products.
4. Indicate the tie-on warning label which the customer must remove and read.
5. Advise the user that any smell given off by the appliance will clear away after a little use.
6. Point out that these instructions must be retained in a safe place for future use.

Maintenance

Servicing should be carried out regularly by a competent person in accordance with these instructions and the relevant regulations, to ensure the safe and correct operation of the appliance.

At least once a year check for debris in the flueway. If soot has accumulated ensure that the chimney is swept clean.

Before commencing any service or replacement of parts, turn off the main gas supply **and ensure that the fire is cold.**

When ordering spare parts please quote appliance serial number which can be found on the data badge plate.

Following a service, a check should be made for clearance of combustion products, using the procedure detailed in these instructions.

Ceramics

Examine the coals and ceramic blocks for signs of cracking and replace if necessary. Handle ceramic components with care. Dust off any soot or deposits with a soft brush. Do not vacuum clean.

Removal of burner

To remove the burner proceed as follows:

1. Turn off the gas supply by the isolation cock.
2. Disconnect the 8mm pipe from the elbow at the left hand side of the burner.
3. Remove the 2 screws holding the burner to the hearth and lift the burner out of the opening.
4. Reassemble in the reverse order.
5. After servicing check for gas soundness.

Cleaning the fire

Black paint: Use only a clean damp cloth. Do not use any cleaning agents.

Brass parts: Use Brasso or Duraglit ensuring that it does not come into contact with the black paint finish.

IMPORTANT - The paint finish is durable and heat resistant, however it will be damaged if plaster, cement or wallpaper paste is allowed to come into contact with it. **Protect the appliance during rebuilding or decorating work.**

Replacement of parts

Before commencing any servicing always ensure that the fire is isolated from the gas supply and that the fire is cold. After servicing always check for gas soundness.

Replacement of gas tap/FSD/piezo igniter

1. Turn off the gas supply by isolation cock.
2. Lift off the front fret and remove the coals and ceramic blocks.
3. Remove 2 screws holding burner to hearth.
4. Undo multidirectional gas connection.
5. Remove burner from fireplace.
6. Pull off control knob.
7. Remove the 2 screws securing the Data Badge plate and remove the plate.
8. Disconnect ignition lead to the igniter unit.
9. Disconnect all 3-gas connections to gas valve as well as the connection to the thermocouple.
10. Remove 2 screws securing the valve to the mounting bracket, and discard old tap/FSD/piezo igniter complete.
11. Assemble the new tap/FSD/piezo igniter on the mounting bracket. *Ensure that the filter is in position in the pilot outlet orifice on the tap body.*
12. Reassemble the appliance in reverse order.
13. Replace the ceramic blocks and coals (see Figs. 4 and 5).
14. Turn on the gas supply and check for soundness.

Note: The igniter is not replaceable separately.

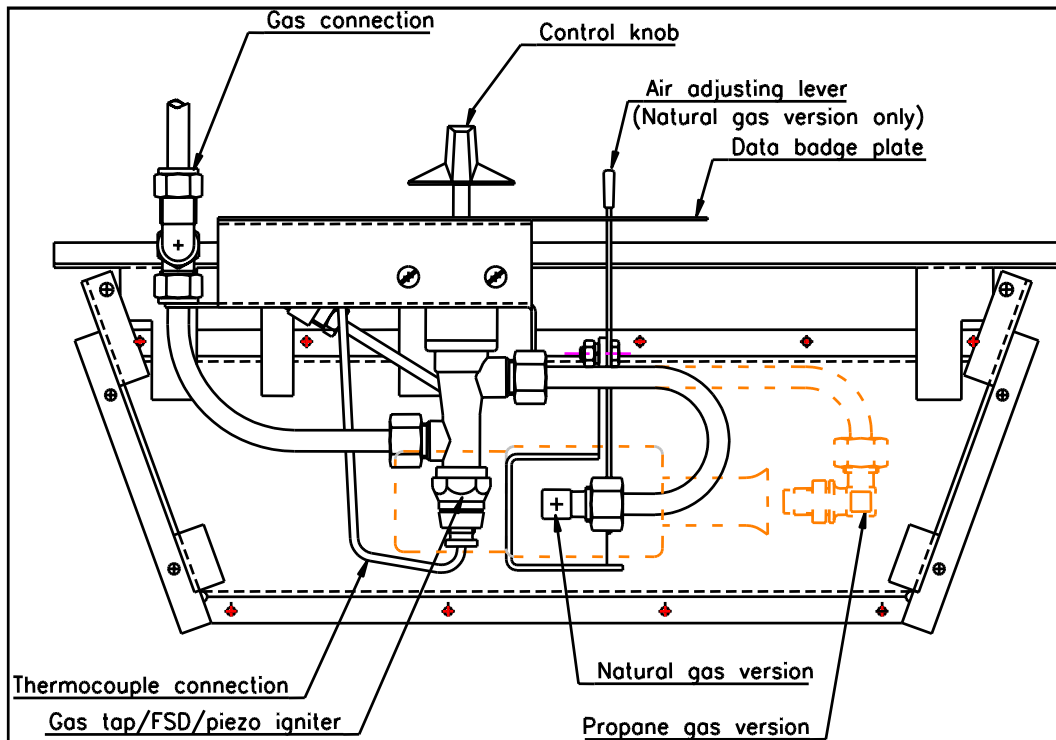

Fig. 8 Underside of burner

Replacement of main injector

1. Repeat operations 1 - 5, as described for 'Replacement of gas tap/FSD/piezo igniter'.
2. Remove gas pipe from gas tap/FSD/piezo igniter to injector.
3. Unscrew injector and replace, making certain that the jet size stamping corresponds to the specification on the Data Badge plate.
4. Reassemble in reverse order.
5. Turn on the gas supply and check for soundness.

Replacement of ignition & pilot assembly

1. Repeat operations 1 - 7, as described for 'Replacement of gas tap/FSD/piezo igniter'.
2. Disconnect thermocouple connection to the gas tap/FSD/piezo igniter.
3. Disconnect pipe from base of pilot burner.
4. Pull off connector on the base of the igniter probe.
5. Remove 2 screws on the burner and remove ignition unit complete.
6. Fit new pilot assembly and reassemble in reverse order.
7. Turn on the gas supply and check for soundness.
8. Check operation of ignition system.

SPARE PARTS

When ordering spare parts please quote part numbers as listed below:

	NATURAL GAS	L.P.G. (Propane)
Gas tap / FSD / piezo igniter	BV50023	BV50147
Oxypilot assembly	BA50004	BA50041
Injector	BI70800	BI70530
Back ceramic	BC11300	BC11300
Centre ceramic	BC11296	BC11296
Front ceramic	BC11295	BC11295
Set of 20 loose coals	BC50422	BC50422

NOTE: No liability can be accepted unless this product has been installed and operated strictly in accordance with these manufacturer's instructions
 U.K. Registered Design 2040268. British Patent Application 9414887.1
 Design right reserved © Legge Fabheat Ltd.