

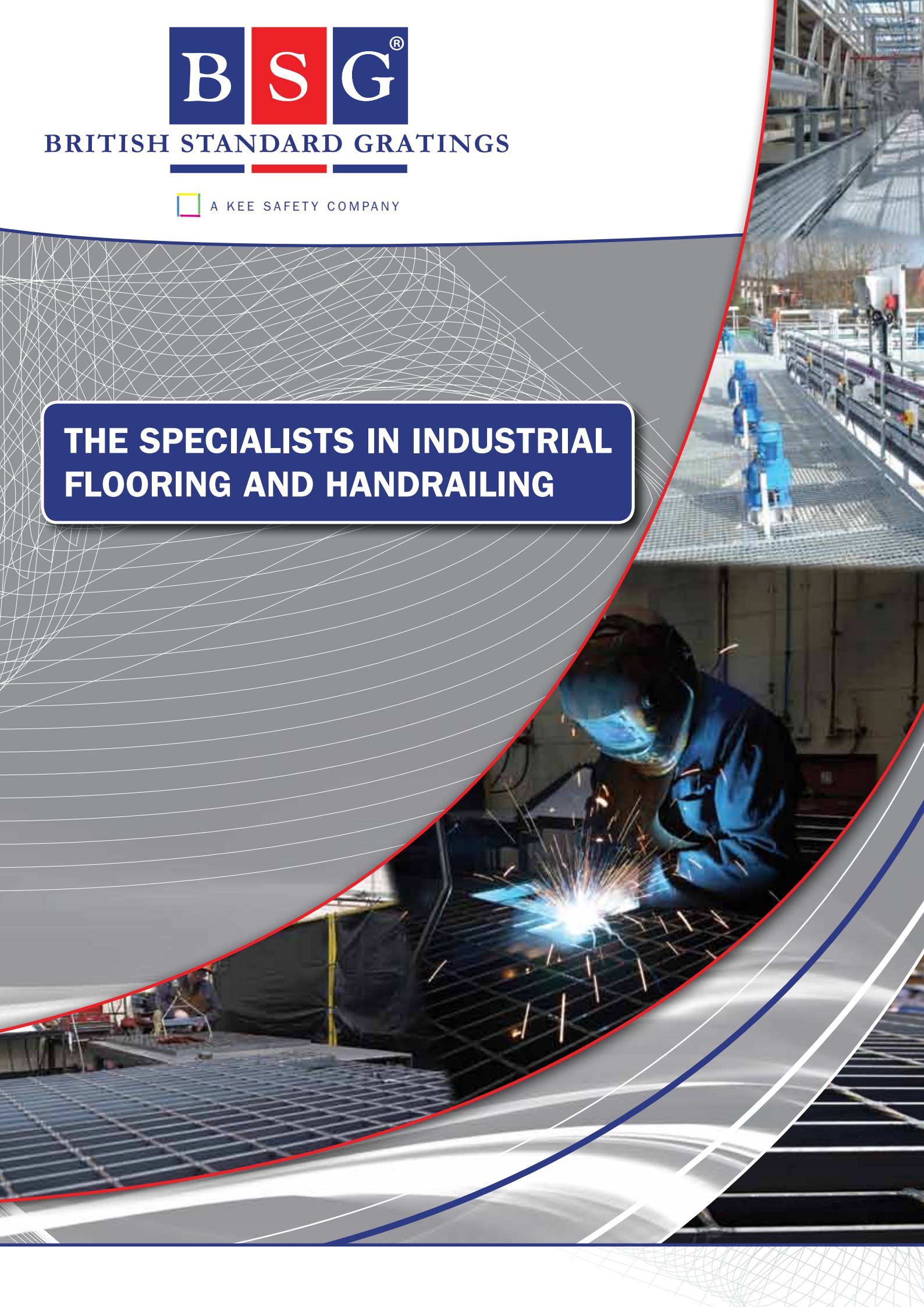

BRITISH STANDARD GRATINGS

 A KEE SAFETY COMPANY

**THE SPECIALISTS IN INDUSTRIAL
FLOORING AND HANDRAILING**



BRITISH STANDARD GRATINGS

From Oil Refineries and Process Plants to the smallest access walkway, there is a requirement for different types of **industrial flooring** and **handrailing**. Gratings produced from steel and other materials normally offer the best flooring solution for all conditions giving a high strength to weight ratio together with maximum drainage.

British Standard Gratings manufacture a wide range of different products to cater for varying requirements and our management team has over 100 years combined experience in this industry.

Market conditions dictate that **bespoke products** are often required and British Standard Gratings have manufactured to customers requirements on many occasions.

This brochure gives a general overview of the products supplied by **BSG**. More technical detail including load tables can be seen on our website www.bsgratings.com



BSG PRODUCT RANGE:

- **Open Steel Flooring / Gratings**
- **Heavy Duty Gratings**
- **Handrail Standards / Stanchions**
- **Plated Gratings**
- **Temporary Edge Protection**
- **Stairtreads**
- **Handrailing / Balustrades**
- **Durbar / Chequer Plate**
- **Ladders and Safety Gates**
- **Steel to steel connection fixings**



FORGEWELDED GRATINGS

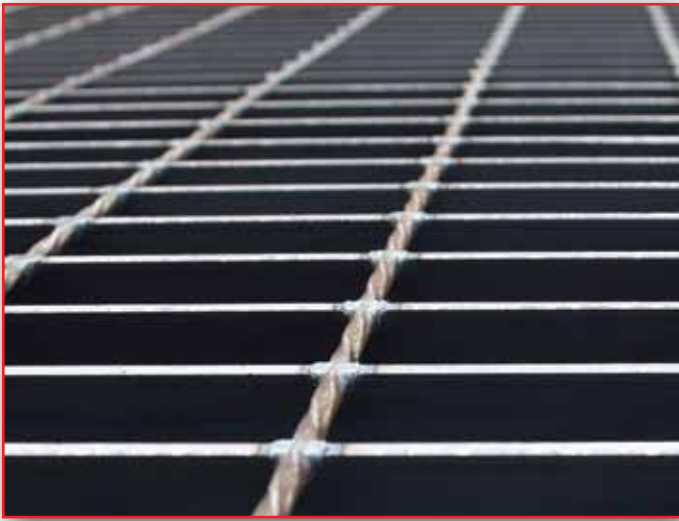

BSG gratings are manufactured using the most advanced forgewelding method, a procedure whereby the simultaneous application of electric current and hydraulic pressure is applied to each joint thus producing a one-piece construction.

Gratings are constructed from load bearing bars (flat bars on edge) held in position by twisted transverse bars.

Load bearing bars can be supplied as plain or with a serrated top surface.

The load bearing capability of a grating is determined by the size of the load bearing bar and the pitch of these bars (the centre to centre dimension).

All main types are available with load bars at varying centres. Technical details and load tables can be seen on our website www.bsgratings.com.

TYPES

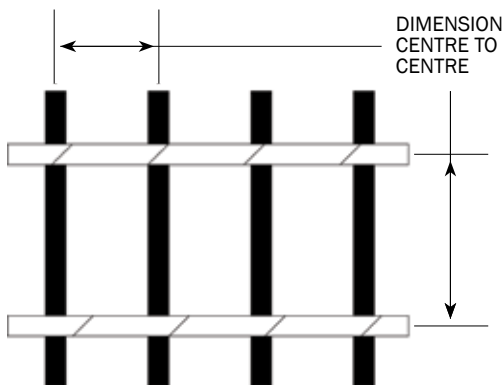

ADVANTAGES OF BSG GRATINGS:

- **No corrosion traps around joints**
- **High strength to weight ratio**
- **Allows shaping without loss of strength**
- **Available plain or serrated**
- **Allows passage of heat, light, water and ice**

Grating Clip

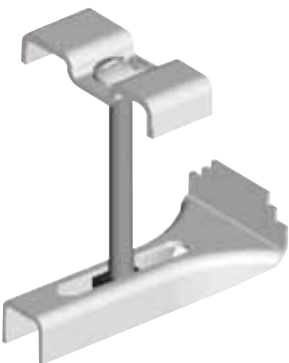

Gratefix



Grating Clip is the most economical method of fixing down open steel grating and can be fixed from the top side only. It is designed to suit 30-41mm grating bar centres.

Gratefix is a heavy duty method of fixing down grating and is tested by TÜV for vibration. This product is used for short sections of grating that require a high clamping force to resist movement.

STAIPTREADS

Manufactured from **BSG** gratings, stairtreads are supplied with welded on end plates for bolting to staircases and have a pyramid pattern sighting bar as standard.

Stairtreads are manufactured from all types of **BSG** gratings dependant upon customer specification or size of stairtread. Certain size stairtreads are available from stock.

A full range of stocked items can be found on our website www.bsgratings.com.



HEAVY DUTY GRATINGS



A range of Heavy Duty Gratings is produced as a welded construction, with load bearing bars generally at 41mm or 50mm centres and round transverse bars at 100mm. However this range is flexible to suit specification or loading criteria.

BSG will design and fabricate Heavy Duty Gratings to suit most requirements. The gratings illustrated are 140mm deep used on the Cardiff Bay Barrage, designed to accommodate the largest Heavy Goods Vehicles.

Heavy Duty Gratings are suitable for all types of abnormal loads or large unsupported spans in many applications including: Bridge Decking, Trench Covers, Jetties, Vehicle Inspection Pits, Grain Intake Run-Over Grids and Screens.

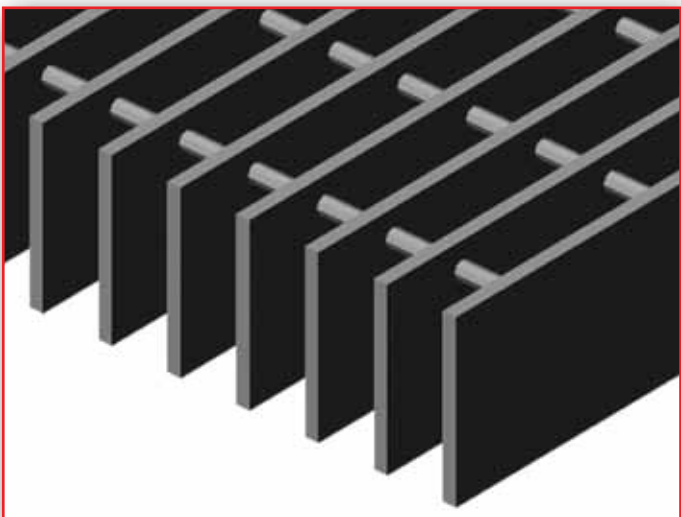

DURBAR PATTERN FLOORING

For applications where a solid floor is required **BSG** will detail and fabricate panels of durbar pattern / chequer plate. Standard thicknesses available are 4.5mm, 6mm, 8mm, 10mm and 12.5mm determined by the required load and the unsupported span of the support structure. Applications include platforms, stairtreads, landings, trench covers, and other applications where a solid walking surface is required.



PLATED GRATINGS

Plated gratings provide the designer with the strength and span capabilities of open steel flooring but with a solid platform surface. This is generally constructed from a substructure of open type flooring with 3mm or 5mm thick bearing bars and depths to suit the required span and loading criteria. A durbar or plain plate is welded onto the top surface which has the effect of drastically increasing the strength and giving the following benefits:

- **Greater unsupported spans requiring less supports**
- **35% to 50% of the weight of a conventional solid equivalent**
- **250% stronger and 600% stiffer than Durbar plate**
- **Reduced overall cost**

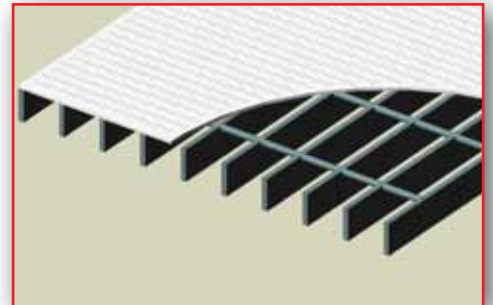

DURBAR FLOOR FIXINGS

FloorFix and **FloorFix HT** are designed for fixing Chequer/Durbar plate flooring from the top side only without drilling, welding or shot firing into the supporting steel. They have been tested by TÜV for vibration conditions to suit such applications as machine shops and pedestrian walkways.



HANDRAIL STANDARDS

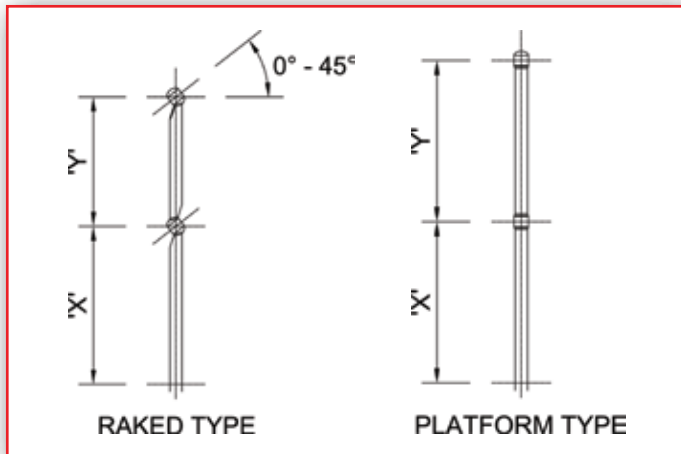

BSG handrail standards are manufactured from tube or solid bar. Standards are manufactured with one, two or multi balls. Ball centres "Y" are flexible to suit customers requirements or any applicable regulations.

TUBULAR STANDARDS

- Manufactured from tube of either 33.7mm, 42.4mm or 48.3mm diameter.
- Ball sizes differ to suit the size of handrailing passing through.
- 63mm diameter balls to suit 33.7mm diameter handrailing.
- 82mm diameter balls to suit 33.7mm, 42.4mm and 48.3mm diameter handrailing.



SOLID WELDED STANDARDS

- Manufactured from 32mm diameter and 38mm solid bar. Ball sizes differ to suit the handrailing passing through.
- 60mm diameter balls to suit 33.7mm diameter handrailing.
- 70mm diameter balls to suit 33.7mm and 42.4mm diameter handrailing.

BASE TYPES

Standard base details are as below:

- Rectangular bases are generally 12mm or 15mm thick with 18mm diameter holes.
- Standard offset = base plate thickness + 1/2 diameter of the shank.
- Special bases can be manufactured to customers requirements.

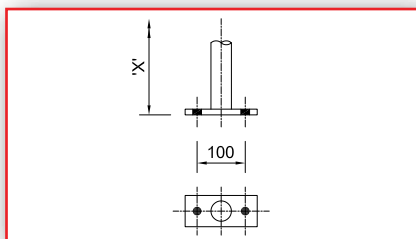

RECTANGULAR FLAT BASE

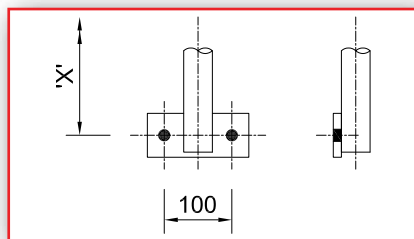

HORIZONTAL SIDE PALM

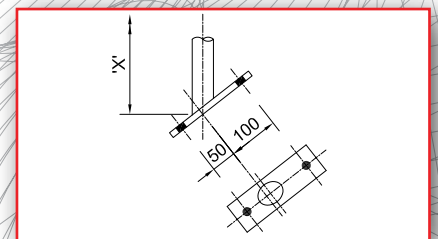

RAKING FLAT BASE

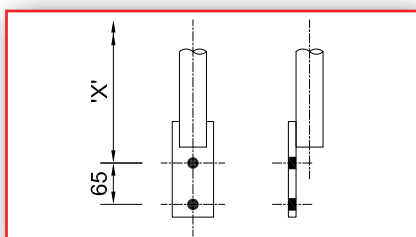

VERTICAL SIDE PALM

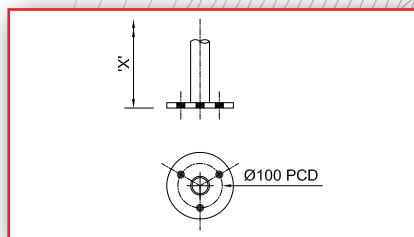

CIRCULAR FLAT BASE

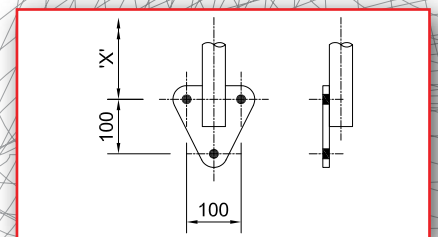

TRIANGULAR SIDE PALM

TUBULAR STICKS & STANDARDS FROM STOCK

SELF COLOUR STICKS WITHOUT BASES

Shank	Ball dia.	Rail dia.
33.7	63	33.7
42.4	63	33.7
42.4	82	42.4
48.3	82	42.4

GALVANISED STANDARDS WITH BASES

Base Type	
Flat	Platform Type
HSP	Platform Type
Raked Flat	Raked 38° and 42°
Raked HSP	Raked

150 x 65 x 12 Loose Bases, complete with 2 - 18mm dia. holes.

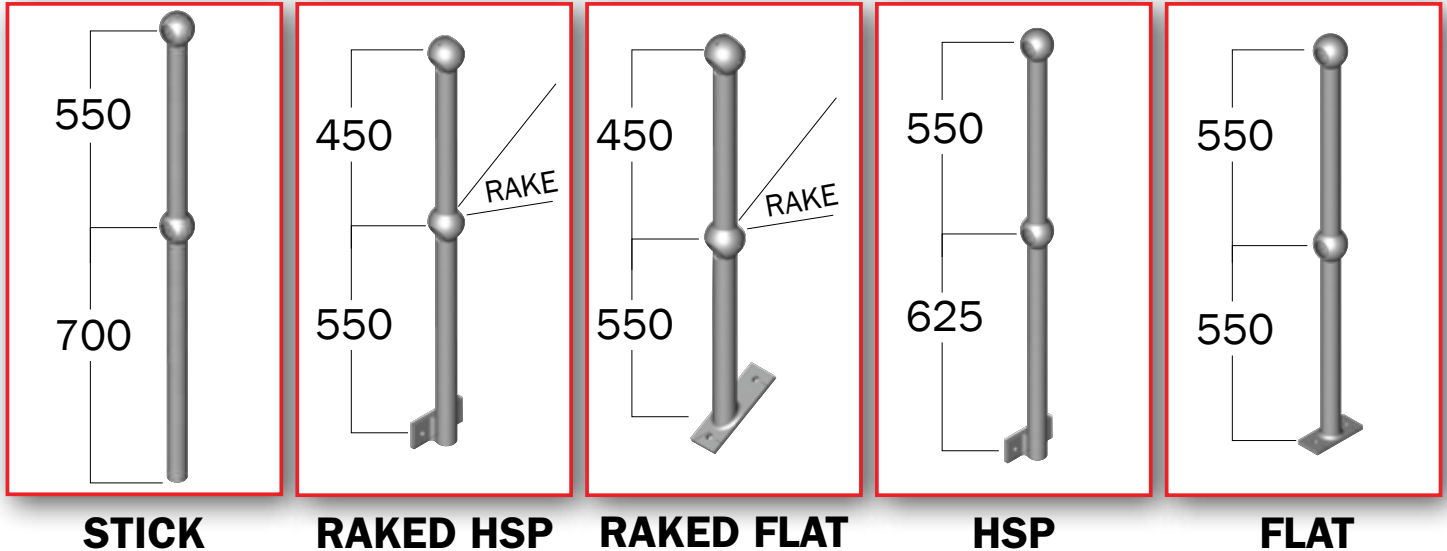

All stocked Standards have 42.4mm dia. shanks with balls to suit 33.7mm dia. rail.

All baseplate fixing holes are 18mm dia. Refer to base plate details on page 7.

A full range of stocked items can be found on our website www.bsgratings.com.

The dimensions shown are for our stocked range. However these can be changed to suit customers requirements or any applicable regulations if requested.

TOEPLATE CLAMPS



BSG offers from stock galvanised Toe Plate Clamps (TPC), which can be used in situations where a toe plate is required to be fixed to handrail standards without the need to drill holes

- TPC are available for 33.7mm dia, 42.4mm dia. and 48.3mm dia. uprights
- 90 degree clamps and straight couplers also available to join toe plate lengths.



HANDRAILING



BSG handrailing is manufactured from 33.7mm, 42.4mm or 48.3mm diameter tube either galvanised, hot dipped galvanised or self colour finishes.

Fabricated handrailing is delivered complete with all necessary bends and joints, and is clearly marked for a quick and simple installation.

Alternatively handrail sections can be formed to your specific requirements.

A range of ex-stock bends, handrailing joints and fittings is also available.



Complete range of FastClamp® fittings can be seen on www.fastclamp.com.

TEMPORARY EDGE PROTECTION

In conjunction with major Steel Construction Companies, **BSG** has developed a low cost, effective temporary edge protection system.

Compared with traditional systems and scaffolding the **BSG** system offers many benefits:

- **Significant cost savings**
- **Available in kit form or assembled frames**
- **Simple and rapid installation**

COMPONENT PARTS:

- 33.7mm diameter 2 ball uprights, "sticks"
- Multi ball upright when 3 or more rails are required
- Standard lengths of 33.7mm diameter tube for site running
- 42.4mm diameter sockets for welding or bolting to structure
- Kick flat/toe board clamps
- Steel or GRP toe board
- Sleeve joints and 90 degree elbows
- Hook on mesh panels with integral kick flat



LADDERS AND SAFETY GATES



BSG supply caged and uncaged fixed access ladders.

Constructed in steel generally to BS 4211, ladders are manufactured from 65mm x 10mm stringers with 20mm dia solid rungs at 250mm centres.

Safety cages are fabricated from 50mm x 8mm hoops with 5 no. vertical straps and are of bolted construction.

The opening at the top of ladders should be protected by means of a self closing safety gate.

Self closing safety gates can be supplied in a variety of forms:



- Half height gates
- Full height gates
- Full height gates with integral toe plate
- Gates with mesh infills, if required
- Gates with standard spring mechanism
- Gates mounted to handrail standards
- Sold from stock

STEEL TO STEEL CONNECTION FIXINGS

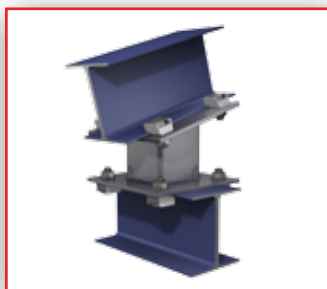

BSG supplies an extensive range of clamping products designed for making steel to steel connections without the need for drilling or welding.

STEELWORK FIXINGS

BeamClamp steel to steel connection products encompass a range of steelwork fixings, floor fixings and suspension fixings.



CAVITY FIXINGS

BoxBolt - an approved blind cavity fixing used for structural steelwork where access is restricted to one side only.

More information at www.beamclamp.com



BRITISH STANDARD GRATINGS

A KEE SAFETY COMPANY

**British Standard Gratings, Cradley Business Park
Overend Road, Cradley Heath, West Midlands B64 7DW
Tel: 01384 563 434 Fax: 01384 563 435
E-mail: sales@bsgratings.com Website: www.bsgratings.com
(Access Technologies Ltd trading as British Standard Gratings)**

