

2019 | AIR CONDITIONERS

# AIR CONDITIONERS

2 0 1 9

LG HVAC SOLUTION



**LG Electronics**

<http://www.lg.com>

<http://partner.lge.com>

Copyright © 2019 LG Electronics. All rights reserved.

Distributed by



# EUROPE SALES INFRASTRUCTURE

-  Europe B2B Regional Head Office
-  National Sales Office
-  Air Conditioning Academy
-  European Distribution Center
-  Europe Energy Lab
-  Production Site

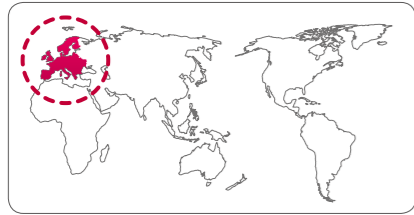

# GLOBAL PRODUCTION SITE



## LG Energy Labs in Europe

LG Energy Labs are driven to fulfill the commitment of meeting all the requirements regarding energy efficiency and environmental demands. Each LG Energy Lab is an innovative site dedicated to provide essential commercial and residential products in heating, ventilation and the latest energy efficient air conditioning solutions. Additionally, as a showcase, the LG Energy Lab is equipped with complete monitoring and control systems. The performance of all products are tracked and analyzed by a team of Research and Development engineers based in France, Finland and Korea, ensuring maximum efficiency and reliability during the complete products' lifecycle.



## European Air Conditioning Distribution Center

LG's European Air Conditioning Distribution Center is centralised in Oosterhout, the Netherlands. Supplying and delivering products to 15 countries in Europe, this Distribution hub has contributed to quick and seamless delivery, direct shipping for smaller orders and bespoke delivery to air conditioners. The hub tries to manage inventory efficiency by complying with the LG EU's established inventory pool.

# TOTAL HVAC SOLUTION PROVIDER

Ever since manufacturing Korea's first exclusively home designed air conditioner in 1968, LG has remained as a pioneer and an epitome of air conditioning innovation. LG has been the world's best selling manufacturer of residential air conditioning solutions. In 2008, LG accomplished the target sales for more than 100 million air conditioners. Encouraged by its success rate and technological leadership in the residential air conditioning sector, LG has expanded its wings into system air conditioning as well.

LG has established itself as an inimitable / exemplary HVAC and energy solution provider, investing in new technologies and adding chillers, VRF systems, and building management systems (BMS) to its comprehensive product portfolio. Including a wide range of innovative solutions, LG delivers unparalleled customer service.

LG produces expert air conditioning professionals at its academic centers, of which there are nearly 80 worldwide. These academic centers provide workshops and training programs that offer excellent hands-on experience. Additionally, LG provides advanced and highly sophisticated tools for HVAC system engineers and installers,

including its time saving LG Air Conditioner Technical Solution (LATS) software. LG also operates several state-of-the-art R&D facilities all across the planet.

One such facility is the Energy Lab, a purpose-built R&D and testing center in northern France. Helping to keep the company ahead of the competition, the scientists and engineers at the Energy Lab study the ramifications of different environmental conditions on LG's products. This indepth research and analysis enables LG to tune its solutions to the specific environmental demands of each individual market. Combining the best technologies with the intellectual ideas, LG's high quality products have now earned the favoritism of customers in over 100 countries.

# INDEX

008 - 119  
**RESIDENTIAL**

012 - 061  
WALL MOUNTED

062 - 119  
MULTI SPLIT



120 - 203  
**COMMERCIAL**

120 - 203  
SINGLE SPLIT



204 - 238  
**HEATING**

204 - 238  
THERMA V



# R32 REFRIGERANT

## HIGHLY EFFICIENT GREEN REFRIGERANT

R32 is environment friendly and classified as a highly efficient 'Go Green' refrigerant.

### Reducing Global Warming & Ozone Layer Depletion

The quantity of R32 refrigerant used is appreciably low as compared to the R410A refrigerant. Consequently, this results in decreasing the potential of global warming and minimal depletion of the ozone layer. Comparative case studies of the different refrigerants are indicated in the table and chart as below:

	R410A	R32
Composition	Blend of R32 50% + R125 50%	Pure R32 (No blend)
GWP (Global Warming Potential)	2087.5	675

### High Refrigerant Compression Rate

High refrigerant compression rates lead to high capacity as compared to existing refrigerant R22, and R410A.

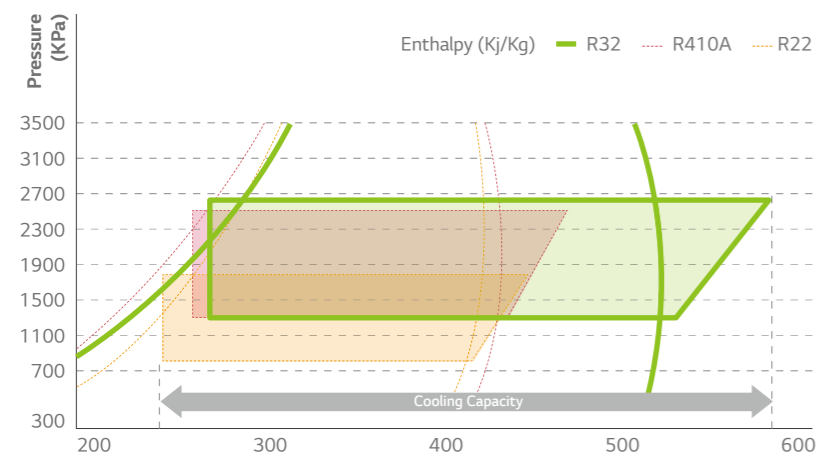

# RESIDENTIAL

WALL MOUNTED





MULTI SPLIT



WALL MOUNTED  
**LINE-UP**

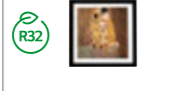



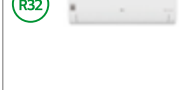

**INDOOR UNIT**

○ Single Split Only   ○● Compatible   ● Multi Split Only

MODEL	KBTU KW	5	7	9	12	15	18	24
		1.5	2.1	2.6	3.5	4.2	5.3	7.0
Prestige				○ H09APNSM	○ H12APNSM			
ARTCOOL Gallery				○● A09FR.NSF	○● A12FR.NSF			
ARTCOOL Mirror			● AM07BPNSJ	○● AC09BQ.NSJ	○● AC12BQ.NSJ		○● AC18BQ.NSK	○● AC24BQ.NSK
ARTCOOL Silver				○● AC09SQ.NSJ	○● AC12SQ.NSJ		○● AC18SQ.NSK	
Deluxe			● DM07RPNSJ	○● DC09RQ.NSJ	○● DC12RQ.NSJ		○● DC18RQ.NSK	○● DC24RQ.NSK
Standard Plus		● PM05SPNSJ	● PM07SPNSJ	○● PC09SQ.NSJ	○● PC12SQ.NSJ	● PM15SPNSJ	○● PC18SQ.NSK	○● PC24SQ.NSK
Standard				○ S09EQ.NSJ	○ S12EQ.NSJ		○ S18EQ.NSK	○ S24EQ.NSK

**OUTDOOR UNIT**

○ Single Split Only   ○● Compatible   ● Multi Split Only

MODEL	KBTU KW	9	12	14	16	18	21	24	27	30
		2.6	3.5	4.1	4.7	5.3	6.2	7.0	7.9	8.8
Prestige		○ H09APU24	○ H12APU24							
ARTCOOL Gallery		○ A09FR.UL2	○ A12FR.UL2							
ARTCOOL Mirror		○ AC09BQUA3	○ AC12BQUA3			○ AC18BQU2		○ AC24BQU24		
ARTCOOL Silver		○ AC09BQUA3	○ AC12BQUA3			○ AC18BQU2				
Deluxe		○ DC09RQU2	○ DC12RQU2			○ DC18RQU2		○ DC24RQU24		
Standard Plus		○ PC09SQUA3	○ PC12SQUA3			○ PC18SQU2		○ PC24SQU24		
Standard		○ S09EQUA3	○ S12EQUA3			○ S18EQU2		○ S24EQU24		

\* ARTCOOL Gallery is available in May, '19  
※ Refer to multi split line up for 5, 7, 15KBTU indoor unit connection.

---

# WALL MOUNTED

Prestige | Artcool | Deluxe | Standard Plus | Standard



# PRESTIGE

## DUAL Inverter



LG Prestige offers one of the most comprehensive air conditioning solutions with supreme energy efficiency and providing a tranquil environment.

---

# ARTCOOL Gallery

## DUAL Inverter

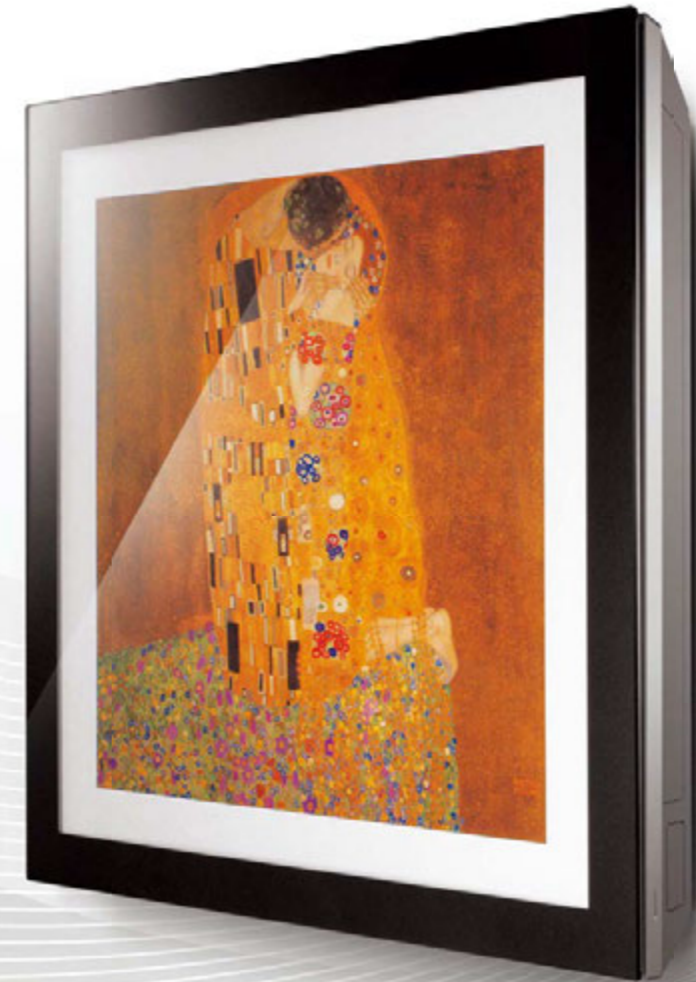

The design of LG air conditioners is fashionably elegant in such a way that it reigns supreme compared to others. Customise your space.

---



# ARTCOOL

## DUAL Inverter



In addition to modern lines and classic style, LG ARTCOOL offers the most outstanding air conditioning solution in a complete and attractive package.

---

# DELUXE

## DUAL Inverter



LG retains it's leading position in supplying RACs, incorporating the essential and fundamental elements of air conditioner solutions.

---

# STANDARD PLUS

## DUAL Inverter



New Standard Plus is a compact size unit with powerful cooling performance and in intelligible and convenient design.

# STANDARD

## DUAL Inverter



Standard model displays all the sophisticated features of general RAC integrated with LG's more advanced technology.



# CORE TECH



## Dual Inverter Compressor

### • What is the Dual Inverter Compressor?

A compressor is the heart of an air conditioner, and monitoring whether it works properly, effectively, or noisily that can cause stress as well as cost more money. LG's Dual Inverter Compressor provides an effective solution, resulting in an air conditioner that cools faster, lasts longer, and operates quieter than conventional models.



### • How it Works

#### Varied-Speed Dual Rotary

A compressor motor with a wider rotational frequency that is energy efficient and has a higher volumetric quick cooling capacity than any conventional compressors.

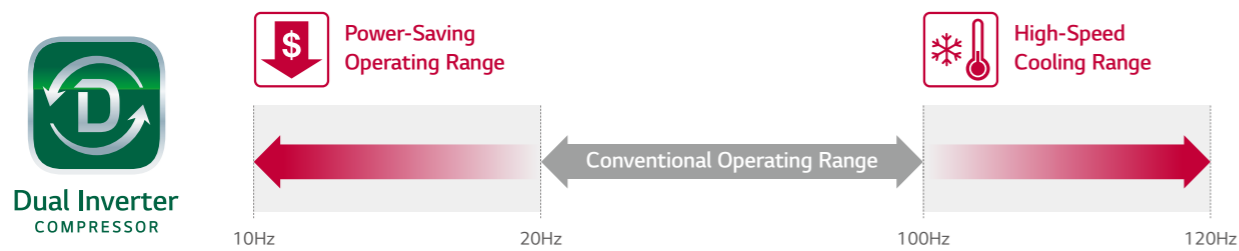

### • Product Reliability Improvement

The Dual Inverter Compressor reduces the vibration and with it the sound pressure levels. The reduction in vibration reduces the possibility of fractures occurring in the the surrounding pipework.

## R32 Refrigerant

### • Pain Point

Due to accelerated global warming and the destruction of the ozone layer, various international conventions and meetings are held to enhance restrictions to the use of refrigerant or enforce the use of eco-friendly refrigerants. In order to reduce environmental destruction, refrigerant R32 is internationally acclaimed for being Eco-friendly. It has the unprecedented feature as a low volume refrigerant that is as efficient as any conventional refrigerant; thus qualifying as a green refrigerant.



### • How it Works

Utilising a small amount of the R32 refrigerant also qualifies it to be a highly green efficient system.

#### Alleviate Global Warming & Ozone Layer Destruction

R32 efficiently works even in small volume compared to existing R410A refrigerant, which decreases potential hazard of global warming.

	R410A	R32
Composition	Blend of R32 50% + R125 50%	Pure R32 (No blend)
GWP (Global Warming Potential)	2087.5	675

#### High Compressibility

R32's high compressibility rate gives more powerful cooling performance and efficiency compared to existing refrigerant R22 and R410A.

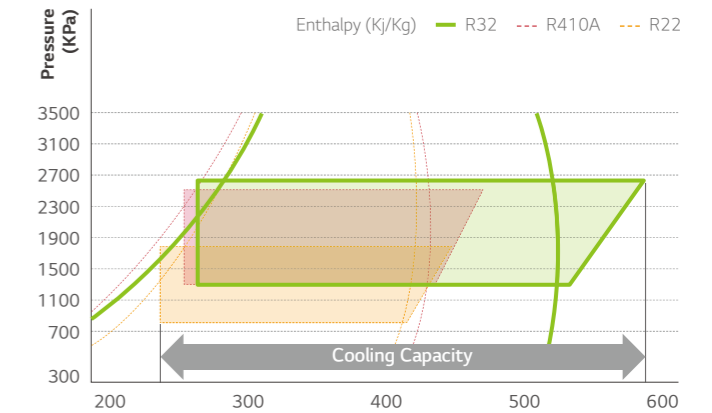

### • Benefit

Eco-friendly Refrigerants that can prevent environmental pollution.

#### High-Efficiency & High-Performance Refrigerant

Reduce refrigerant charge by 15% R410A Preparation for an increase in efficiency for both heating and cooling. R410A Preparation for easy install. (R410A blended refrigerant, R32 single refrigerant)

# SMART

## Embedded Wi-Fi

Control your air conditioners by using Android or iOS based smartphones. This advanced technology provides you many benefits.

### • LG Smart ThinQ



Download the 'LG SmartThinQ' app from the Google Downloads or the Appstore.



LG Smart ThinQ

### • How it Works

#### Embedded Wi-Fi modem

Enable "LG Smart ThinQ" on your air conditioner.



By using the embedded Wi-Fi modem, get ready for innovation without boundaries.



#### Easy Registration and Log-in

Follow the interactive set-up LG Account steps that will activate smart ThinQ's impressive features.

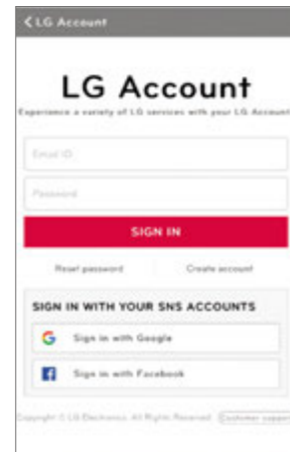

#### Wi-Fi Connectivity

Each individual member of your family can customise the air conditioner temperature and fan speed accordingly and then save the settings in their app to run it later. These settings can be saved for each air conditioner too.

#### Multiple Devices



#### Multi-Control



\* Can be controlled by multiple users, but not simultaneously

### • Benefit

#### Simple operation for various functions

On/Off, Current Temp



Mode, Set Temp

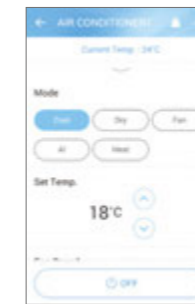

Vane Control

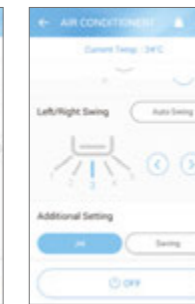
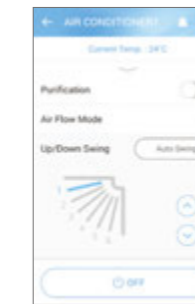

#### Straight forward Management

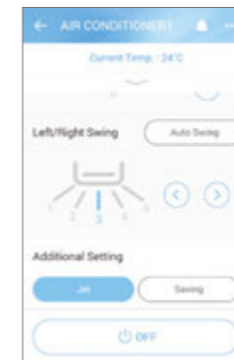

Reservation



Energy Monitoring



Smart Diagnosis



Filter Management

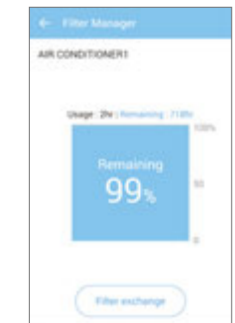

#### Integrated Home Appliances Control

Control / Monitor all your LG appliances from one place.



#### Access your air conditioner anytime and from anywhere

with a Wi-Fi equipped device and LG's exclusive control app, Smart ThinQ.



# SMART

## Smart Diagnosis

Smart Diagnosis allows you to check setup, installation, troubleshooting and other information conveniently from your smartphone.

\* Specifications may vary for each model.  
\* When connected to Multi ODU, Smart Diagnosis function may not be supported.

### • What is the Smart Diagnosis?

Smart Diagnosis allows users to conveniently check setup, installation, troubleshooting and other information directly from a smartphone.

\* Builds upon widespread smartphone use and offers greater USP diversification  
\* Perfect for consumers who are unable to view information about their air conditioner via a display or remote control.

### • How it works

By using “LG Smart ThinQ” App and clicking “Start Smart Diagnosis”, monitor and check diagnosis results conveniently via Wi-Fi.

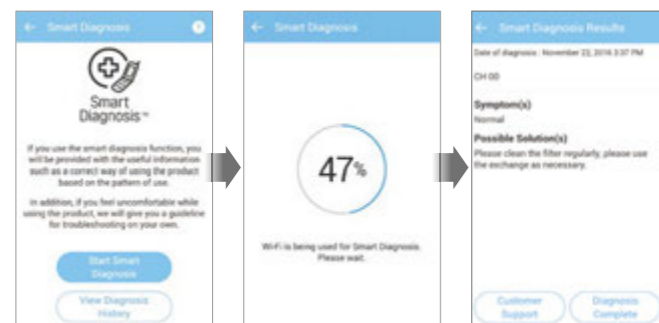

\* When the model doesn't provide embedded Wi-Fi, diagnose by buzzer sound with the same app and remote controller.

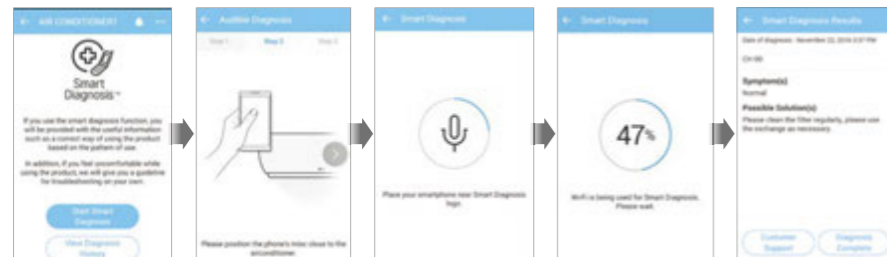

### • Benefit

Easily comprehensible error messages make detecting a solution and contacting the service center simple and convenient

#### For consumer



#### For Installer and SVC



- Easily check operational status of a product without a display or one that provides limited information
- Save energy by monitoring key operational information and power consumption
- Using the Maintenance Guide helps to improve device performance and increase product life-span.

- Understand the product better by easily confirming operational status and information
- Intuitively diagnose problems by comparing current and past usage data
- Maintain installation capabilities and reduce installation errors by quickly confirming device operational status

# SMART

## SIMs

By connecting SIMs chip, you can check the status of your air conditioner and diagnose problems from your smartphone.

\* Specifications may vary for each model.  
\* When connected to Multi ODU, SIMs function may not be supported.

### • What is the LG SIMs?



Monitor the status of your air conditioner and accurately diagnose problems by connecting it to a smartphone via a SIMs chip.

\* SIMs : Smart Inverter Monitoring System

### • How It Works



#### SIMS App

1. Use a SIMs chip to connect a smartphone to an air conditioner.
2. Monitor and diagnose problems in real time using the SIMs app.



### • Benefit

#### Easy Monitoring

Diagnose problems anytime, anywhere with a SIMs chip.

#### Easy Diagnosis & Quick Response

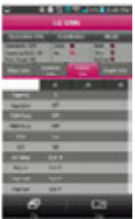
Easily monitor IDU/ODU and diagnose problems. Save and review diagnostic data.

 <p><b>Main</b> Current outdoor temperature Indoor temperature Inverter Comp frequency Operating opening Error code / Frequency limits Indoor. Outdoor fan speed</p>	 <p><b>Indoor Unit</b> Indoor Unit Capacity / Operation Mode THM mode / REM mode FAN operating condition / EEV opening Room Temperature / Suction Temperature Intermediate Temperature Exit Temperature</p>
 <p><b>Outdoor Unit</b> Frequency / Fan RPM DC Link / Input Current Input Voltage EEV operation mode Restart timer Compressor mode / EEV opening</p>	 <p><b>Chart</b> Room Temperature Heat exchanger pipe temperature Compressor discharge temperature Frequency / Outdoor temperature Compressor suction temperature Electric current / Voltage</p>

#### Certificate



\* Smartphone Requirements (iOS : 6.1 or later, Android : 2.3 or later)

## Low Refrigerant Detection

Early notification of low refrigerant protects your air conditioner from a risk of damage.

\* Specifications may vary for each model.  
\* Depending on the experimental conditions.  
\* When connected to Multi ODU, Low Refrigerant Detection function may not be supported.

### • How It Works

#### Early Detection of Low Refrigerant Levels

The Air Conditioner is automatically shut down when low refrigerant level is detected.

#### 3 Checkpoints for Low Refrigerant Level :

- 1) The heat exchanger temperature is comparatively cool
- 2) The outdoor unit is working properly
- 3) The energy consumption is working under a standard pattern

If any of the above conditions are not met, for a maximum of 4 times, after 15 minutes of Air Conditioner operation, a Low Refrigerant level is detected and the Air Conditioner is shut down.

#### Capacity and Effectiveness of the Refrigerant Levels

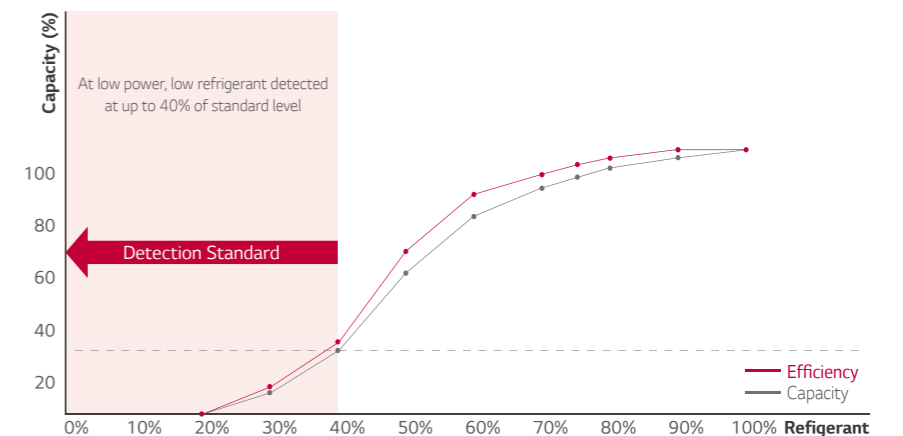

\* This function only works under the following conditions:  
- Indoor/Outdoor temperature is up to 20 degrees Celsius  
- Cooling and dehumidification mode

### • Benefit

#### Longer Lifespan for Air Conditioner

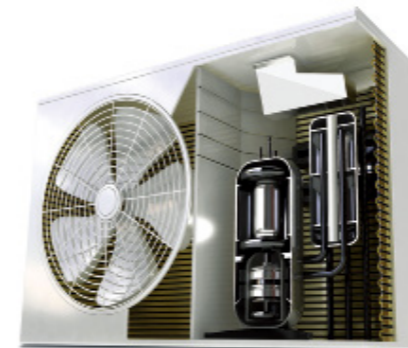

Notify You of Low Refrigerant Levels

When Low Refrigerant Level is detected, it alternately shows CH and 36 on the display.

\* Some models show CH and 38 alternately on the display.

# ENERGY EFFICIENCY

## Supreme Energy Efficiency

LG's revolutionary Inverter technology boasts powerful yet quiet performance while minimising energy consumption. With world class energy efficiency, bask in the cosiness of the atmosphere surroundings whilst saving energy.

\* Based on H09AL Model  
\* Specifications may vary for each model.

### • High Efficient Compressor and Reversing Valve

#### Rotary Compressor and Motor Efficiency

The number of suction connections has been reduced from two to one to increase the efficiency of the refrigerant compression during low speed conditions. The DC motor in LG air conditioners remains unsurpassable incomparable to in the world's best efficiencies.

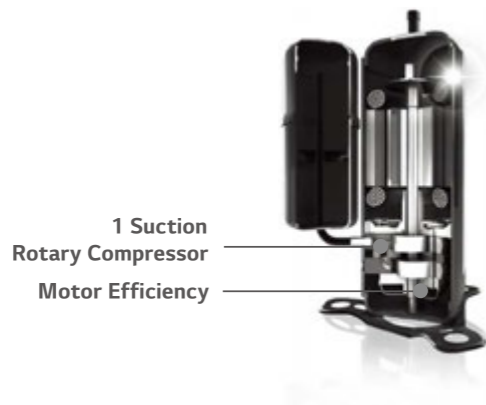

#### Bi-Stable Reversing Valve

The Input power of 4-way valve has been reduced to 0W by using a Bi-Stable type.

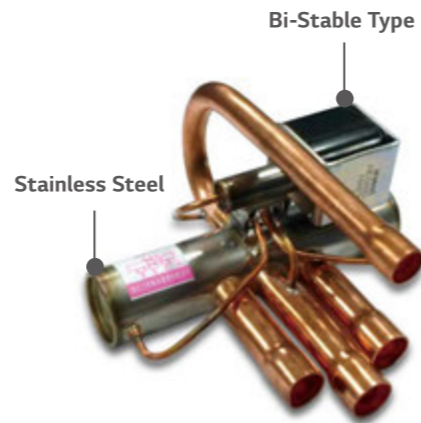

### • Improved Inverter Drive Efficiency

Used to optimise the time of current flow by controlling the number of converter switching according to energy consumption status. Displays comparatively higher performance and advanced energy efficiency than conventional Inverter air conditioner by reducing power loss with an advanced material component called SiC.

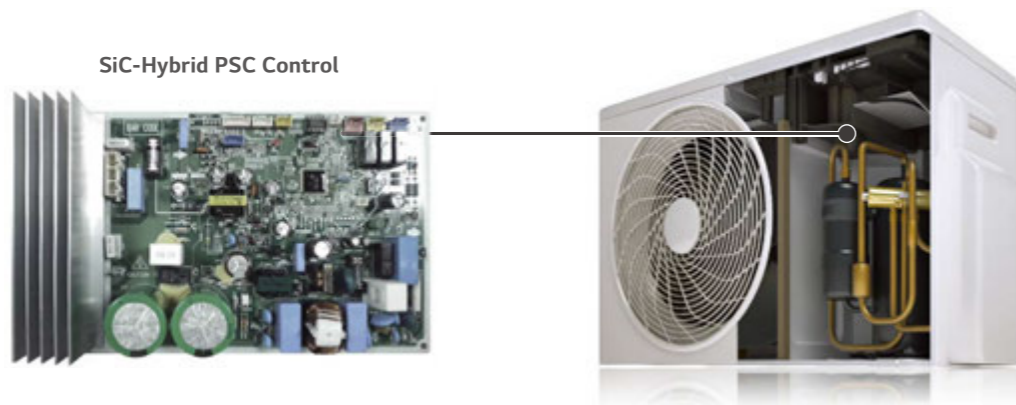

## Active Energy Control 4 - Step

LG's Active Energy Control adjusts the energy consumption level and cooling capacity by controlling maximum frequency of the compressor motor.

\* Specifications may vary for each model.  
\* Depending on the experimental conditions.  
\* When connected to Multi ODU, Active Energy Control function may not be supported.

### • Concept & Benefit

Cooling a home can come at a high cost particularly during the hot summer months. Avoid those costs and save energy by taking advantage of LG's 4-Step Energy Control System.

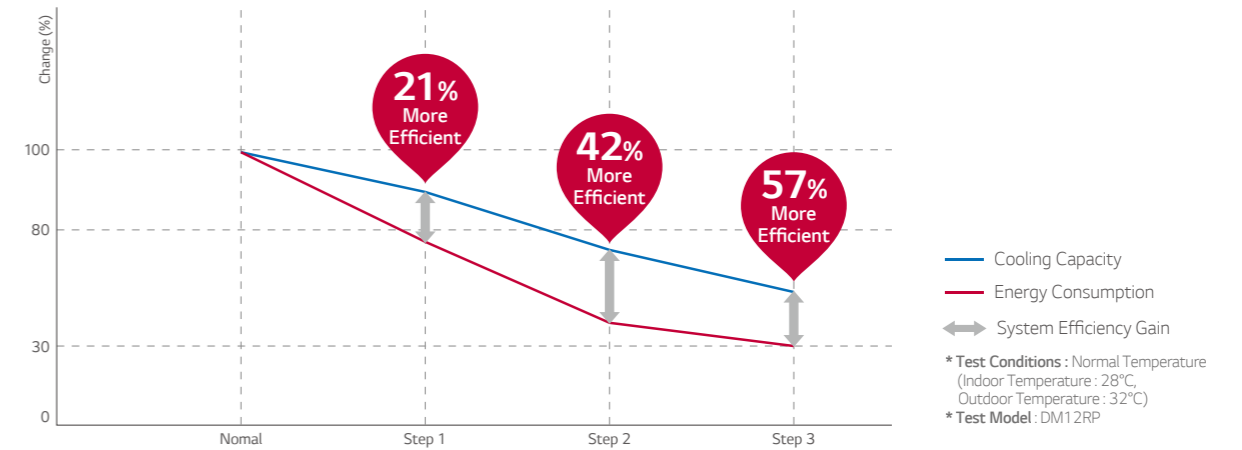

### • How It Works

<p><b>Normal.</b> 100% energy usage</p> <p>Many people and high-activity level</p>	<p><b>Step 1.</b> 80% energy usage</p> <p>Fewer people and moderate-activity levels.</p> <p>1 Clicks</p>
<p><b>Step 2.</b> 60% energy usage</p> <p>Fewer people and low-activity levels.</p> <p>2 Clicks</p>	<p><b>Step 3.</b> 40% energy usage</p> <p>Fewest people with no activity.</p> <p>3 Clicks</p>



# ENERGY EFFICIENCY

## Energy Display

LG's Energy Display panel monitors the amount of energy levels used. Save on energy consumption while enjoying the cooling by checking your energy level on the panel.

\* Specifications may vary for each model.  
\* When connected to Multi ODU, Energy Display function may not be supported.

### • How it Works

#### Magic Display & Remote Control

With the push of a button on the remote control, indoor unit's LCD display shows the current and total energy use, thus making the users aware of reducing energy consumption.

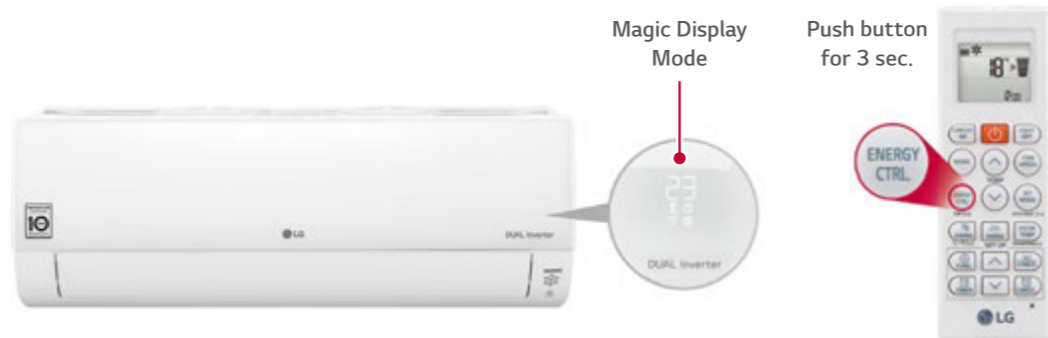

### • Benefit

#### Nomal Mode

Current Setting Temp



#### Electric Power

Displays Current Energy Use



### • Additional Benefit

#### Fan Speed

Display	Speed
F5	High
F4	Medium-High
F3	Medium
F2	Medium-Low
F1	Low

#### Sleep Mode



For example, setting 1hr

# PERFECT HEALTHCARE

## Plasmaster™ Ionizer<sup>PLUS</sup>

The powerful plasma ionizer protects you from bad odors and harmful and contagious particles in the air with over 3 million ions to sterilize not only the air passing through the air conditioner, but also surrounding surfaces for a safer, and cleaner environment.

\* Specifications may vary for each model.  
\* Depending on the experimental conditions.

### • How It Works

#### Sterilization and Deodorization (Utilizes Over 3 Million Ions)

Plasmaster Ionizer+ reduces harmful and contagious microscopic particles by infusing the air passing through the air conditioner with over 3 million ions.

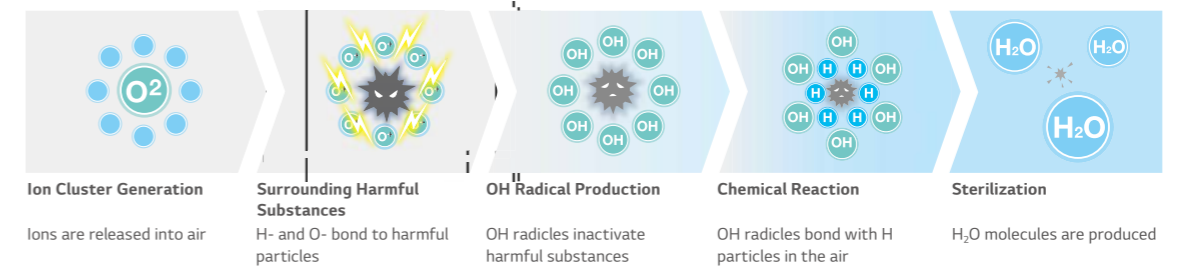

### • Test Result

#### Sterilization Performance Evaluations

Sterilize Bacteria (E.coli colon bacillus) over 99.9% in 30 min.

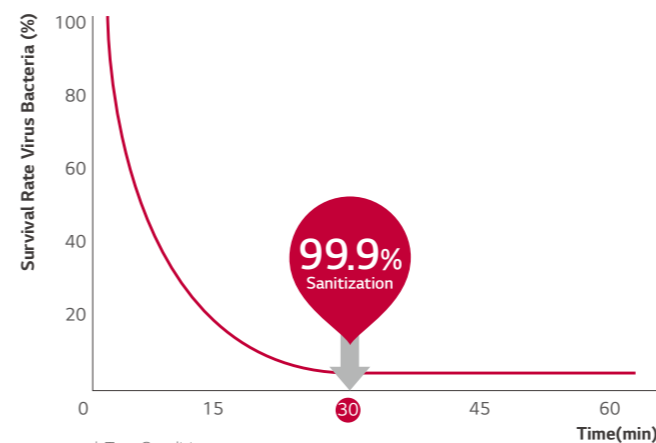

\* Test Conditions :  
Space : 52m<sup>3</sup> Chamber  
Temperature & Humidity : Normal  
Bacteria : Staphylococcus Aureus

#### 2.1 odor strength decrease in 60 minutes

An odor of measured as 2 European odor units (ouE/m<sup>3</sup>) or less indicates that the level of odor falls within permissible limits.

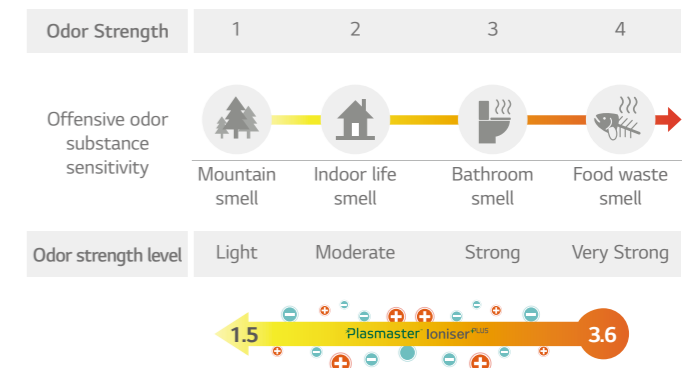

Odor strength reduce 3.6 → 1.5 / The Odor floating in the room as well as curtain and clothes.

# PERFECT HEALTHCARE

## Dual Protection Filter

The Dual Protection Filter collects dust.

\* Specifications may vary for each model.  
\* Depending on the experimental conditions.

### • What is the Dual Protection Filter?

The Dual Protection Filter, designed to capture dust particles over 10 $\mu$ m in size, is the first line of defense and hindrance against finer particles.



### • Additional Benefit

#### Easy to Open

Easily detachable full surface cover helps clean the air conditioner flawlessly.



#### Easy to Clean

The filter is designed for easy handling and quick cleaning, which lengthens its lifespan.



## Auto Cleaning

The interior of the air conditioner is maintained clean by drying off the heat exchanger, then sterilizing the interior once more.

\* Specifications may vary for each model.

### • Pain Point

The main cause of odor within air conditioners is mold and bacteria growing on the heat exchanger. These germs can spread when the heat exchanger is wet.



### • How It Works

#### Cleans Filter with Regular Airflow

The comprehensive auto cleaning function prevents the formation of bacteria and mold on the heat exchanger, providing an enhancing environment.

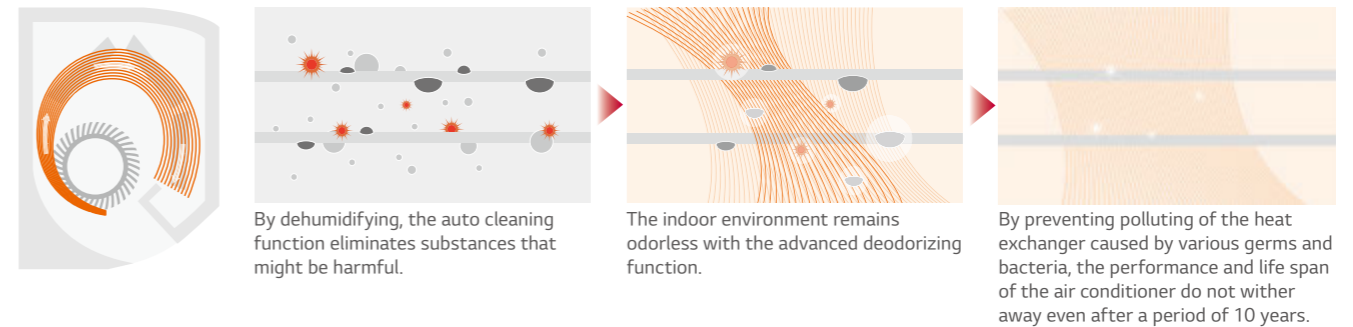

### • Benefit

#### Removes Harmful Particles

Auto Cleaning provides clean air by preventing bacteria, mold and odors that can otherwise accumulate in an indoor unit.



# FAST COOLING & HEATING

## Fast Cooling

The cool airflow reaches all the corners of the room, keeping the space cool and comfortable.

\* Specifications may vary for each model.  
\* Depending on the experimental conditions.

### • How It Works

#### Bigger Skew Fan

A 25% larger skew fan emanates highly powerful blasts of air.

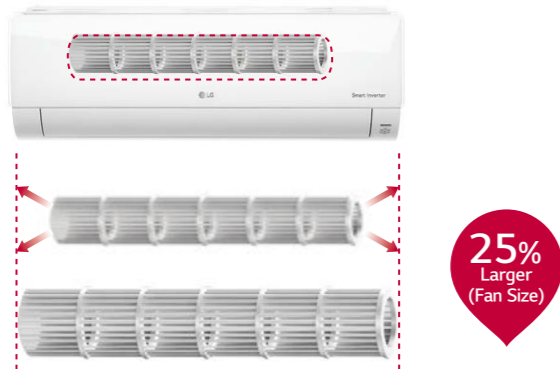

#### Cooling Outlet

A larger, optimally designed cooling outlet emanates to large areas and cools spaces faster.

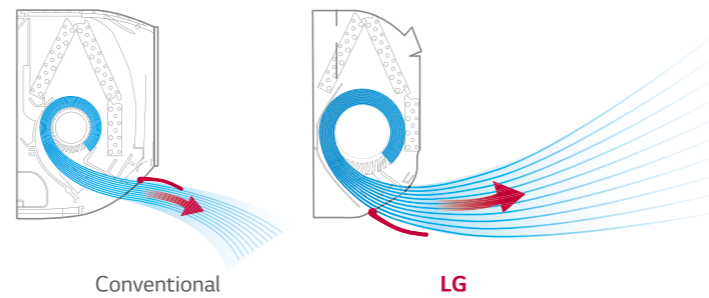





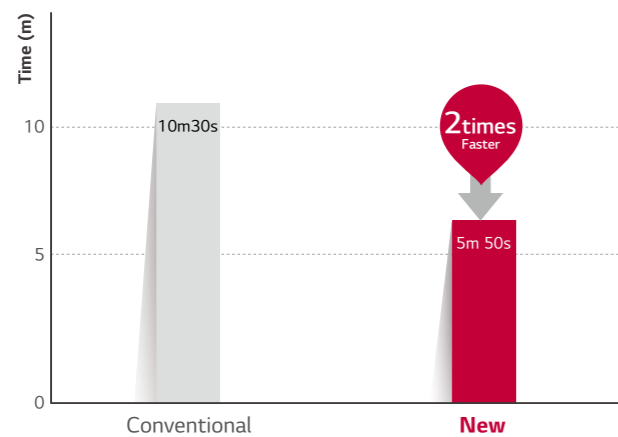

### • Test Result

#### Test Result



\* Test Conditions :  
: Indoor temperature 33°C, Outdoor temperature 35°C,  
Relative humidity 60%, Setting temperature 24°C

#### Changes in Temperature Over 30 Minutes

	Conventional	10min	20min	30min
0.1m				
<b>New</b>				

\* Test Conditions :  
Outdoor temperature : 35°C, Indoor temperature : 33°C,  
Humidity : 60%, Remote control : 24°C High

## Jet Cool

LG air conditioners provide optimized high-speed airflow, which can cool rooms faster while delivering cool air evenly in every direction.

\* Specifications may vary for each model.  
\* Depending on the experimental conditions.

### • How It Works

#### One Click "Jet Mode"

Reduces the temperature of outflowing air to 18°C for 30 minutes with just one click.

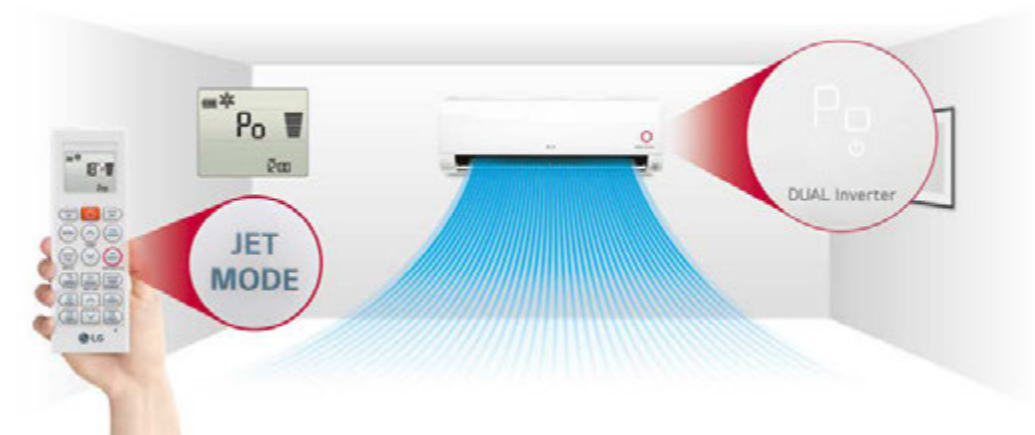

### • More Powerful Performance

By reducing the second vortex, which decreases airflow within the air outlet, and enlarging the fan size, the amount of airflow is increased to 13.0 CMM.

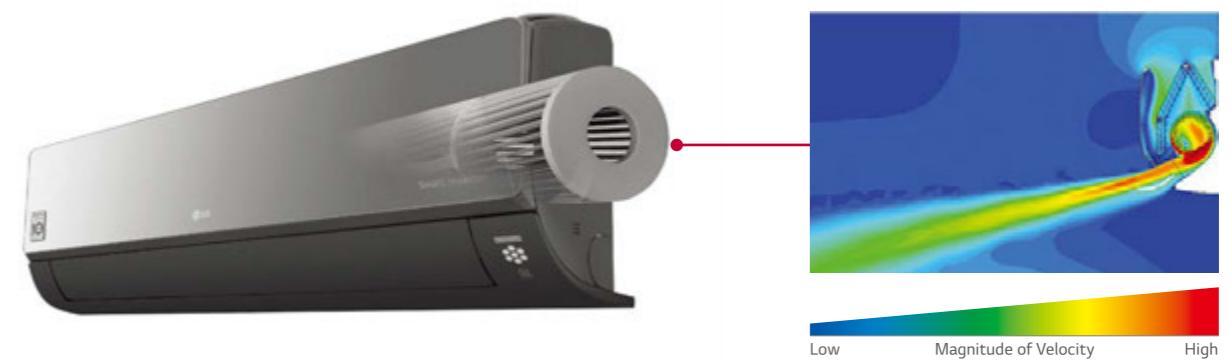

# FAST COOLING & HEATING

## 4-Way Swing

Cool air reaches out to the entire room regardless of where the air conditioner is installed

\* Specifications may vary for each model.

### • How It Works

#### 6-Step Vane, Control up to 70°

The vertical vane, which moves up and down, has 6 different settings including full-auto swing.

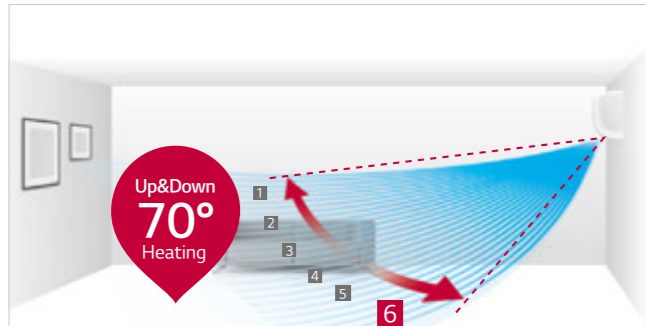

\* Angle can be different from each model and working mode.

#### 5-Step Louver, Control up to 55°

The louver, which sways left and right, has 5 different settings including full auto-swing.



### • Easy and Simple Control

Airflow direction can be changed by LG ThinQ Wi-Fi app.

#### Up/Down Swing

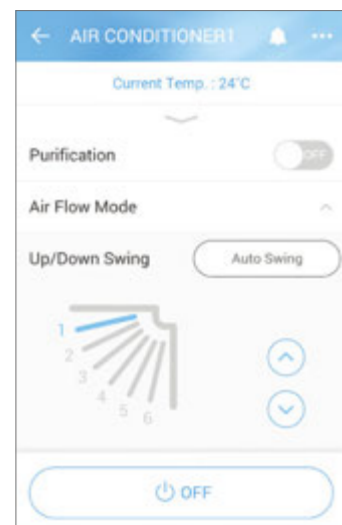

#### Left/Right Swing

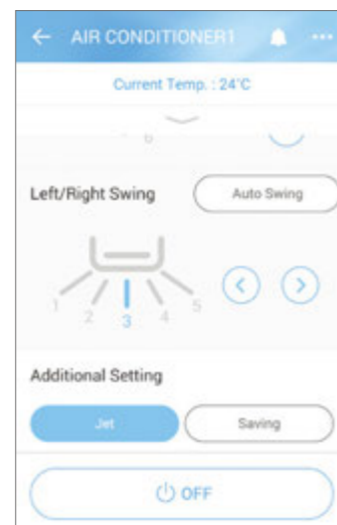

## Fast Heating

LG Residential Air Conditioners satisfy your heating needs while consuming less energy, by heating a wider space in a shorter period of time to create a warm and comfortable living environment.

\* Specifications may vary for each model.  
\* Depending on the experimental conditions.

### • How It Works

#### 4 way Auto Swing (Easy Airflow Control)

4 Way Auto Swing adjusts airflow based on the surrounding environment, allowing for optimal distribution of warm air to living areas and enabling quick heating.

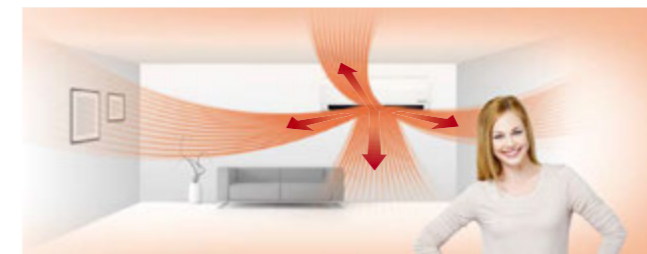

#### Vertical Airflow

When heating, the vane sends heated air downwards to maintain a pleasant and balanced room temperature.

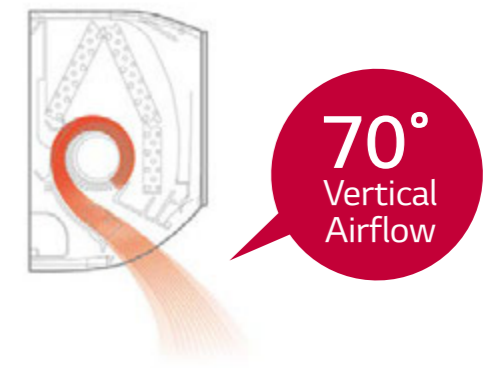

### • Benefit & Test Result

#### 22% Quick Heating

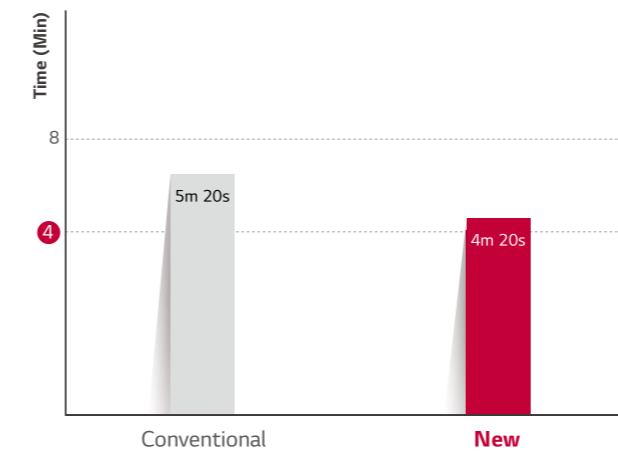

\* Test Conditions :  
Outdoor temperature : 7°C, Indoor temperature : 12°C,  
Humidity : 87%, Remote control : 30°C Power

#### Changes in Temperature Over 20 Minutes

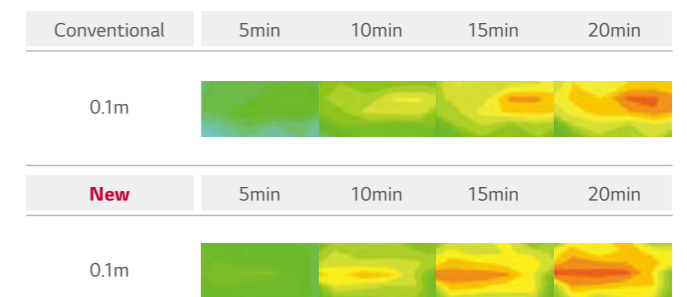

\* Test Conditions :  
Outdoor temperature : 7°C, Indoor temperature : 12°C,  
Humidity : 87%, Remote control : 30°C Power

# EXTREME DURABILITY

## 10-Year Inverter Compressor Warranty

LG, with confidence in product quality, preserves better lives for customers by providing 10 years warranty for Inverter Compressor of Air conditioners.

\* Specifications may vary for each model.

### • What is the 10 Year Warranty?

The compressor is for the Air Conditioner what the engine is to the vehicle. With the 10 year warranty on the compressor, users can avail of the benefits of LG air conditioner for a longer period on time.

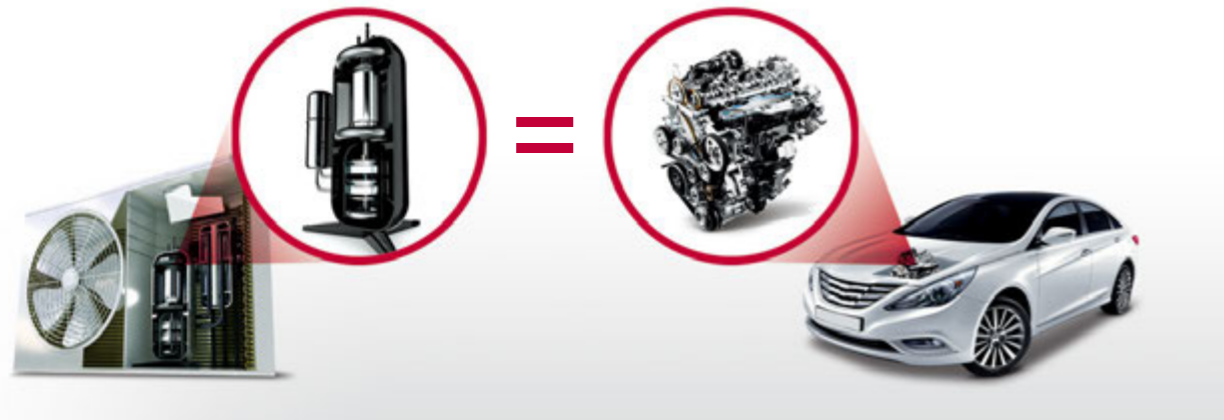

### • Benefit & Verification

#### Reliable Air Conditioner

Product safety is emphasized by offering a 10-year warranty on the compressor to reassure customers about product durability.

#### Verification

TUV Rheinland, Long Term Accelerated-reliability Test & High Marginal Test

- \* Long Term Accelerated-Reliability test  
LG's unique testing method with reinforced operating condition for a product life assurance to test and determine the product life cycle in a short period of time by accelerating the life cycle.
- \* High Marginal Test  
Test method to secure durability in various adverse conditions that may occur in the field by performing comp reliability test against higher pressure and temperature than the designed range of pressure and temperature which the comp operates in.
- \* Verification obtained from TUV Rheinland for 10-year product life cycle



## Gold Fin™

The Gold Fin™ coating protects the surface of the heat exchanger from unnecessary wear and corrosion.

- \* Specifications may vary for each model.
- \* Depending on the experimental conditions.

### • How It Works

#### Crosscut View of Heat Exchanger

The gold-colored special coating on the fin of the heat exchanger prevents corrosion, extending the life of the unit.

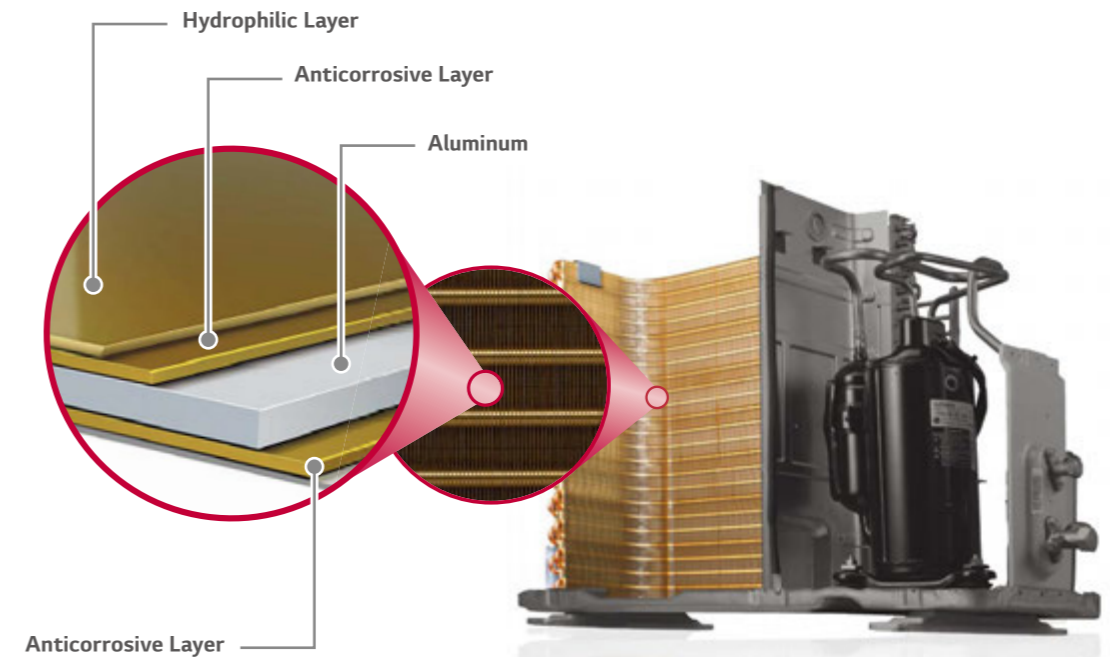

### • Test Result

#### Conventional Fin



#### Gold Fin™



\* Test result 360 hrs. after being exposed to sodium chloride

# COMFORT

## Comfort Air

LG provides pure hygienic and temperature regulated atmosphere surrounding your living space. An automatic vane angle adjustment sets perfect vane angle and air volume.

\* Specifications may vary for each model.

### • Concept

If the air conditioner remains ON while asleep, it can lower body temperature or cause discomfort, especially if the outflow of cool air is directly close to the room's occupants. This can be eliminated by the Comfort Air vane angle thus providing a comfortable environment to the sleeping occupants.

### • How It Works

Control Panel



Comfort Vane

This option conveniently sets an AC's louvers to a preset position so that outflowing air is directed away from a room's occupants.

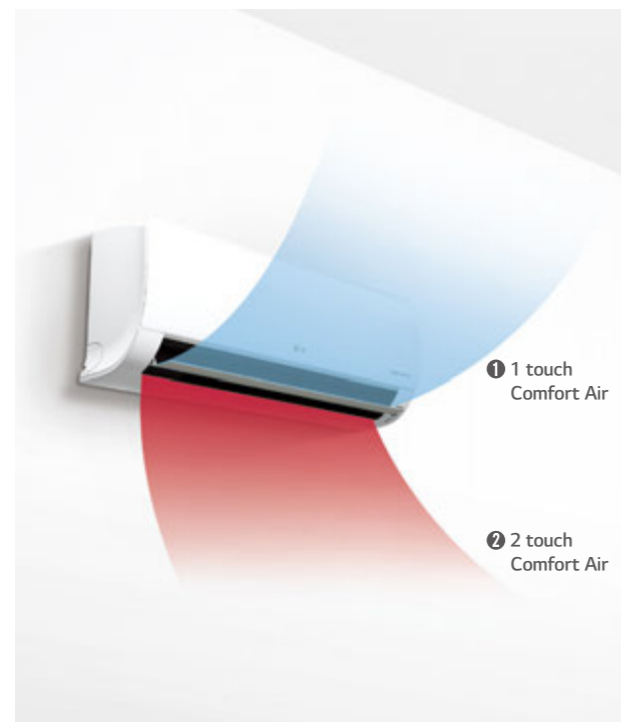

#### Scene 1: Inclines to a maximum 80° angle.

Sets vane angle to highest position : Optimized for gentle airflow cooling.

Indoor Unit Display

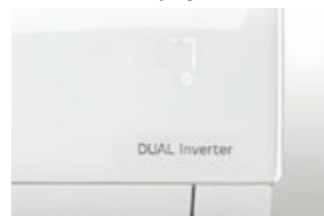

Remote Controller Display



#### Scene 2: Declines to a maximum 10° angle.

Sets vane angle to lowest position : Optimized for gentle airflow heating.

Indoor Unit Display



Remote Controller Display



## Low Noise

LG Air Conditioners operate at 19dB low noise level, moreover provide healthy soft air by just 1 touch.

\* Specifications may vary for each model.

### • How It Works

#### LG's Unique Skew Fan

By minimizing the surface pressure of the fan blade when in contact with the air peak noise are reduced to a level that is among the lowest in the world.

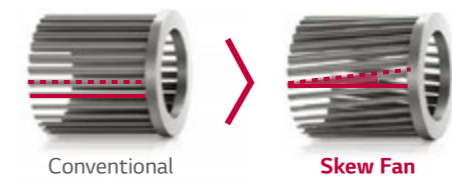

15% Tilted Stabilizer

#### BLDC Fan Motor

With strong torque and powerful ND magnetism as well as precise speed control of 13 different steps for smooth operation, the BLDC motor provides substantial air volume and high static pressure, while keeping electrical and mechanical noise lower, and making high-speed operation available.



Advanced Motor

- Low Efficiency.
- Heat Problem during overhauling.
- Difficult precise speed control.
- Low Electric and mechanical noise.
- Precise speed control durable.

#### ALVC (Active Low Vibration Control)

A speed-error component estimates the load to compensate for imbalances, which are the primary causes of vibration and noise, enabling the rotation of the motor without vibration at low Hz levels.

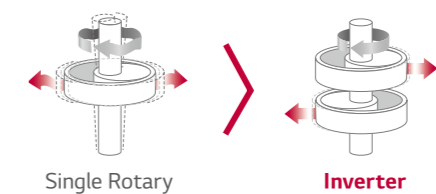

40% Cut Torque Variation

### • Benefit

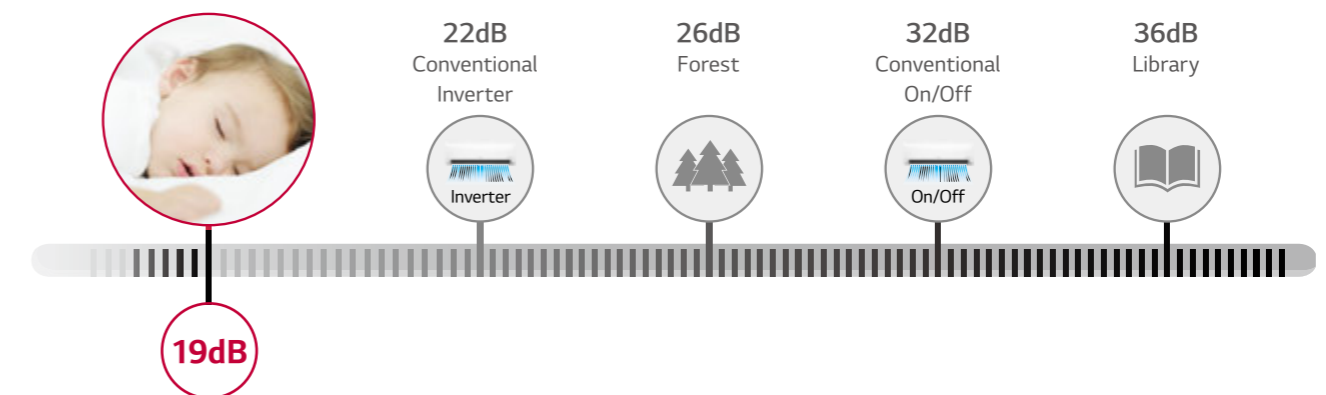

# COMFORT

## Silent Mode

Silent mode ensures a tranquil and serene experience for the user by reducing noise disturbances while you are resting.

\* Specifications may vary for each model.

\* Depending on the experimental conditions.

\* When connected to Multi Outdoor unit, Silent Mode is working by simply setting the dip switch on the PCB of the outdoor unit.

### • How It Works

In Silent Mode, the overall sound level of the outdoor unit drops by up to 3dB and the sound level of the indoor unit also decreases.

#### Press the Silent Button

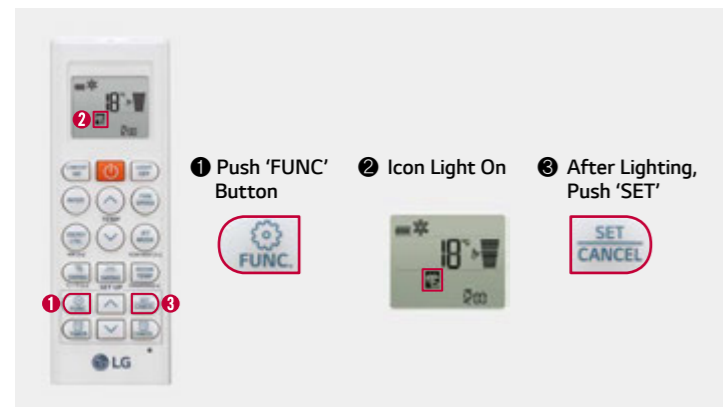

#### Controls the Outdoor Compressor

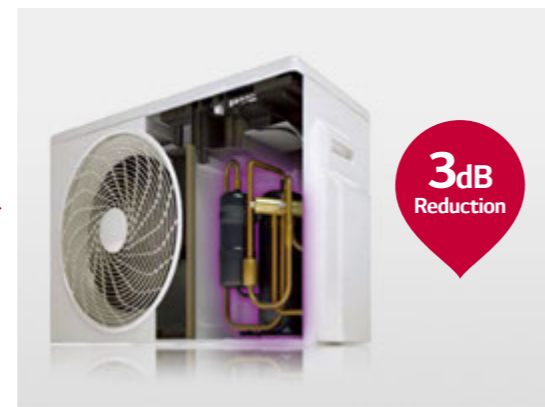

### • Test Result

#### Noise Comparison Graph

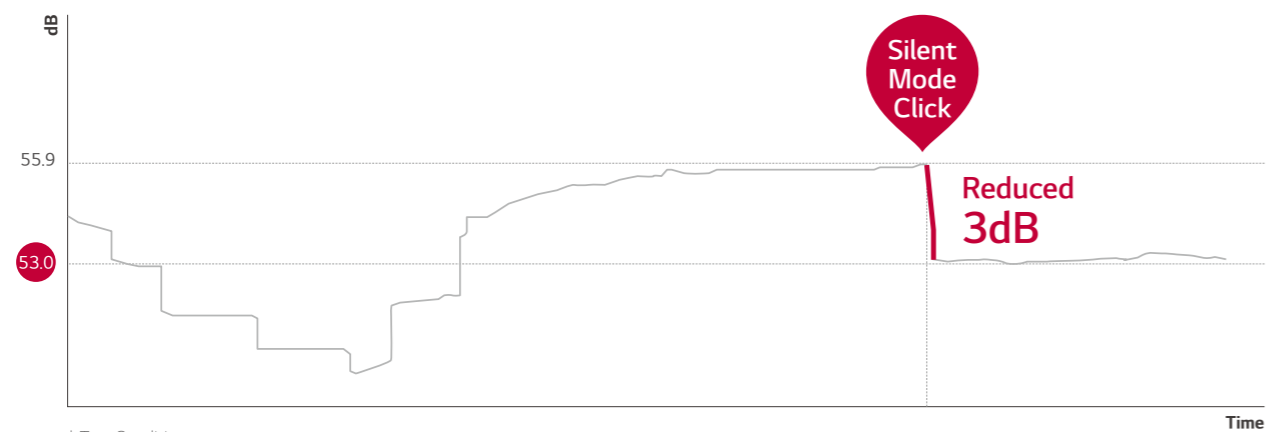

\* Test Conditions  
Spec : Selecting Silent Mode reduces the noise of an outdoor fan unit by 3dB  
Assessment : 36.2 dB emitted from center/side of unit at a distance of 1m.

## Quick & Easy Installation

LG air conditioner is designed for an easy and efficient installation, making possible to install several units in a short period of time

\* Specifications may vary for each model.

### • Concept

By reducing the manpower and time required for installation, it is now possible to install more units in less time.

### • How It Works

#### One Simple Packing Box

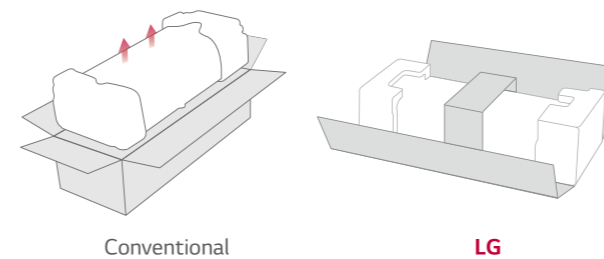

#### Installation Plate Improvement

LG's installation plate is larger and customized to reduce installation time.

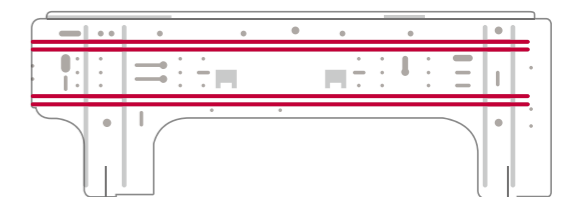

#### Installation Support Clip

A support clip creates adequate space between the wall and the unit for easier installation.

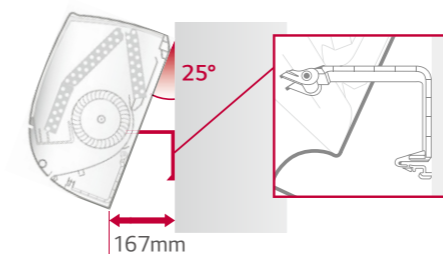

#### Wider Tubing Space

The space provided for tubing facilitates the whole installation process and hides the unorganized parts, making it appear clean and tidy.

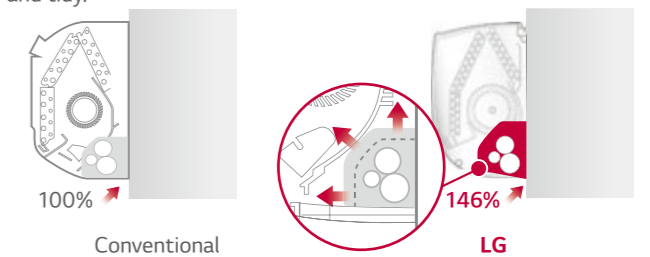

#### Detachable Bottom Cover

The air conditioner's bottom cover is detachable for easier installation and access.

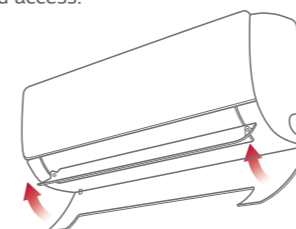

#### Quick button for running test

The test button is conveniently located and easy to find.

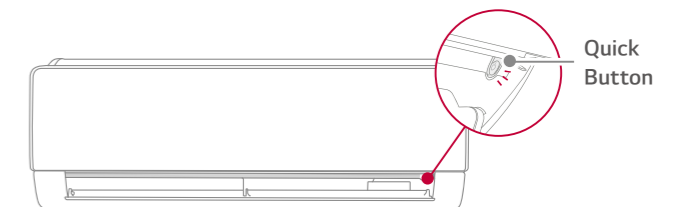

# PRESTIGE



**Dual Inverter COMPRESSOR** **EUROVENT CERTIFIED PERFORMANCE** LG participates in the ECP programme for EUROVENT AC program. Check ongoing validity of certification : [www.eurovent-certification.com](http://www.eurovent-certification.com)

Embedded Wi-Fi

Active Energy Control

Plasmaster Ionizer PLUS

Dual Protection Filter

Plasmaster Auto Cleaning

Jet Cool

4 Way Swing

Fast Heating

Gold Fin™

Low Noise 17dB

Silence Mode 3dB

Quick & Easy Installation

## • Single Combination

UNIT				9K	12K
INDOOR				H09AP.NSM	H12AP.NSM
Capacity	Cooling	Min / Rated / Max	W	300 / 2500 / 4000	300 / 3500 / 4250
	Heating	Min / Rated / Max	W	300 / 3200 / 6900	300 / 4000 / 7320
	Heating -7°C	Rated	W	4300	4700
Power Input	Cooling	Rated	W	490	833
	Heating +7°C	Rated	W	593	785
EER			W/W	5.10	4.20
S.E.E.R.				9.4	9.1
P design C			kW	2.5	3.5
COP			W/W	5.4	5.1
S.C.O.P.				5.2	5.1
P design H			kW	3.2	3.8
Energy Label	Cooling (A+++ to D Scale)			A+++	A+++
	Heating (A+++ to D Scale)			A+++	A+++
Annual Energy Consumption	Cooling		kWh	94	135
	Heating		kWh	862	1045
Sound Pressure	Cooling	S / L / M / H	dBA	19 / 29 / 37 / 42	19 / 29 / 37 / 42
	Heating	L / M / H	dBA	29 / 37 / 42	29 / 37 / 42
Sound Power	Cooling	High	dBA	60	60
	Heating	S / L / M / H	m³/min	6.6/8.7/11.1/12.4	6.6/8.7/11.1/12.4
Air Flow Rate	Cooling	Max (Power)	m³/min	15.5	15.5
	Heating	L / M / H	m³/min	8.7/11.1/14/3	8.7/11.1/14/3
Dehumidification Rate	Cooling		l/h	1.5	1.7
	Heating		l/h	1.5	1.7
Running Current	Cooling	Rated/Max	A	2.5/6.0	3.9/6.0
	Heating	Rated/Max	A	2.9/3.7	7.4/7.4
Starting Current	Cooling	Rated	A	2.5	3.9
	Heating	Rated	A	2.9	3.7
Power Supply			∅ / V / Hz	1 / 220-240 / 50	1 / 220-240 / 50
Circuit Breaker			A	15	15
Power Supply Cable			N x mm²	3 x 1.0	3 x 1.0
Power & Transmission Cable			N x mm²	4 x 1.0 (Including Earth)	4 x 1.0 (Including Earth)
Dimension			mm	875 x 295 x 235	875 x 295 x 235
Net Weight			kg	11.0	11.0
Fan Motor Output			W	30	30
OUTDOOR				H09AP.U24	H12AP.U24
Operation Range	Cooling	Min / Max	°CDB	-10 / 48	-10 / 48
	Heating	Min / Max	°CDB	-25 / 24	-25 / 24
Sound Pressure	Cooling	High	dBA	48	48
	Heating	High	dBA	50	50
Sound Power	Cooling	High	dBA	65	65
Air Flow Rate	Cooling	High	m³/min	49	49
Piping	Length (Odu/Idu)	Min / Max	m	3 / 20	3 / 20
	Elevation (Odu/Idu)	Max	m	10	10
Piping Connection	Liquid	OD(Outside)	mm (inch)	6.35 (1/4)	6.35 (1/4)
	Gas	OD(Outside)	mm (inch)	9.52 (3/8)	9.52 (3/8)
	Drain	OD(Outside)	mm (inch)	21.5 (0.85)	21.5 (0.85)
Refrigerant	Type			R410A	R410A
	Charge at 7.5m		g	1,150	1,150
	Additional charge		t-CO <sub>2</sub> eq	2.40	2.40
	GWP		g/m	20	20
Fan Motor Output	Additional charge		g/m	2087.5	2087.5
Compressor Type	GWP			85	85
Net Weight			kg	43	43
Dimension			mm	870 x 650 x 330	870 x 650 x 330

\* This product contains Fluorinated greenhouse gases (R410A).  
 \*\* S : Sleep / L : Low / M : Medium / H : High  
 \*\*\* Specification, design and feature are subject to change without prior notice.

# ARTCOOL GALLERY



**Dual Inverter COMPRESSOR** **EUROVENT CERTIFIED PERFORMANCE** LG participates in the ECP programme for EUROVENT AC program. Check ongoing validity of certification : [www.eurovent-certification.com](http://www.eurovent-certification.com)

Auto Cleaning

Jet Cool

3 Way Swing

Fast Heating

Gold Fin™

Silence Mode

## • Single Combination

UNIT				9K	12K
INDOOR				A09FR.NSF	A12FR.NSF
Capacity	Cooling	Min / Rated / Max	W	1300 / 2500 / 3500	1300 / 3500 / 4000
	Heating +7°C	Min / Rated / Max	W	1300 / 3000 / 4000	1300 / 3500 / 4500
	Heating -7°C	Rated	W	3000	3200
Power Input	Cooling	Rated	W	700	1090
	Heating +7°C	Rated	W	930	1090
EER			W/W	3.57	3.21
S.E.E.R.				5.3	5.3
P design C			kW	2.5	3.5
COP			W/W	3.22	3.21
S.C.O.P.				3.8	3.8
P design H			kW	2.5	2.5
Energy Label	Cooling			A	A
	Heating			A	A
Annual Energy Consumption	Cooling		kWh	165	231
	Heating		kWh	921	921
Sound Pressure	Cooling	S / L / M / H	dBA	26 / 28 / 40 / 45	26 / 28 / 40 / 45
	Heating	L / M / H	dBA	28 / 40 / 46	28 / 40 / 46
Sound Power	Cooling	High	dBA	60	60
	Heating	S / L / M / H	m³/min	3.8 / 4.4 / 5.9 / 7.7	3.8 / 4.4 / 5.9 / 7.7
Air Flow Rate	Cooling	Max (Power)	m³/min	9.5	9.5
	Heating	L / M / H	m³/min	4.4 / 5.9 / 7.7	4.4 / 5.9 / 7.7
Dehumidification Rate	Cooling		l/h	1.2	1.4
	Heating		l/h	1.2	1.4
Running Current	Cooling	Rated	A	3.5	4.5
	Heating	Rated	A	6.0	6.0
Starting Current	Cooling	Current	A	4.0	5.0
	Heating	Current	A	7.0	7.0
Power Supply	Cooling/Heating	Rated	A	3.5 / 4.0	4.5 / 5.0
Circuit Breaker			∅ / V / Hz	1 / 220-240 / 50	1 / 220-240 / 50
Power Supply Cable			N x mm²	3 x 1.0	3 x 1.0
Power & Transmission Cable			N x mm²	4 x 1.0 (Including Earth)	4 x 1.0 (Including Earth)
Dimension			mm	600 x 600 x 146	600 x 600 x 146
Net Weight			kg	15.0	15.0
Fan Motor Output			W	16.7	16.7
OUTDOOR				A09FR.UJ2	A12FR.UJ2
Operation Range	Cooling	Min / Max	°CDB	-10 / 48	-10 / 48
	Heating	Min / Max	°CDB	-10 / 24	-10 / 24
Sound Pressure	Cooling	High	dBA	49	49
	Heating	High	dBA	51	51
Sound Power	Cooling	High	dBA	65	65
Air Flow Rate	Cooling	High	m³/min	35	35
Piping	Length (Odu/Idu)	Min / Max	m	3 / 15	3 / 15
	Elevation (Odu/Idu)	Max	m	10	10
Piping Connection	Liquid	OD(Outside)	mm (inch)	6.35 (1/4)	6.35 (1/4)
	Gas	OD(Outside)	mm (inch)	9.52 (3/8)	9.52 (3/8)
	Drain	OD(Outside)	mm (inch)	21.5 (0.85)	21.5 (0.85)
Refrigerant	Type			R32	R32
	Charge at 7.5m		g	800	800
	Additional charge		t-CO <sub>2</sub> eq	0.540	0.540
	GWP		g/m	20	20
Fan Motor Output	Additional charge		g/m	675	675
Compressor Type	GWP			43	43
Net Weight			kg	34.1	34.1
Dimension			mm	770 x 545 x 288	770 x 545 x 288

\* This product contains Fluorinated greenhouse gases (R32).  
 \*\* S : Sleep / L : Low / M : Medium / H : High  
 \*\*\* Specification, design and feature are subject to change without prior notice.



# ARTCOOL MIRROR



Dual Inverter COMPRESSOR  
**EUROVENT CERTIFIED PERFORMANCE**  
 LG participates in the ECP programme for EUROVENT AC program. Check ongoing validity of certification : [www.eurovent-certification.com](http://www.eurovent-certification.com)

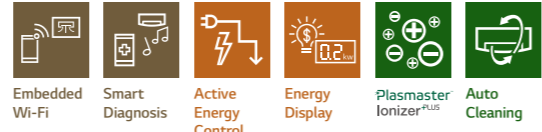

### • Single Combination

UNIT				9K	12K	18K	24K
INDOOR				AC09BQ.NSJ	AC12BQ.NSJ	AC18BQ.NSK	AC24BQ.NSK
Capacity	Cooling	Min/Rated/Max	W	890 / 2500 / 3700	890 / 3500 / 4040	900 / 5000 / 5500	900 / 6600 / 7420
	Heating +7°C	Min/Rated/Max	W	890 / 3300 / 4100	890 / 4000 / 5100	900 / 5800 / 6400	900 / 7500 / 8640
Power Input	Heating -7°C	Rated	W	2600	3000	4200	4850
	Cooling	Rated	W	656	1080	1562	2164
EER	Heating +7°C	Rated	W/W	800	1050	1611	2238
	Cooling	Rated	W/W	3.81	3.24	3.20	3.05
S.E.E.R.				7.0	6.6	7.0	6.9
P design C			kW	2.5	3.5	5.0	6.6
COP			W/W	4.13	3.81	3.60	3.35
S.C.O.P.				4.0	4.0	4.3	4.2
P design H			kW	2.5	2.5	3.9	5.0
Energy Label	Cooling (A++ to E Scale)			A++	A++	A++	A++
	Heating (A++ to E Scale)			A+	A+	A+	A+
Annual Energy Consumption	Cooling		kWh	125	186	250	335
	Heating		kWh	875	875	1270	1628
Sound Pressure	Cooling	S / L / M / H	dB(A)	19 / 27 / 35 / 41	19 / 27 / 35 / 41	31 / 34 / 39 / 44	31 / 34 / 42 / 47
	Heating	L / M / H	dB(A)	27 / 35 / 41	27 / 35 / 41	34 / 39 / 44	34 / 42 / 47
Sound Power	Cooling	H	dB(A)	59	59	60	65
	Heating	L / M / H	m <sup>3</sup> /min	3.0 / 4.2 / 7.5 / 10.0	3.0 / 4.2 / 7.5 / 10.0	8.0 / 10.5 / 13.0 / 14.5	8.0 / 10.5 / 13.1 / 16.1
Air Flow Rate	Cooling	Max (Power)	m <sup>3</sup> /min	12.5	12.5	15.5	20.0
	Heating	L / M / H	m <sup>3</sup> /min	5.6 / 7.2 / 10.0	5.6 / 7.2 / 10.0	11.0 / 13.5 / 16.0	10.5 / 13.1 / 16.1
Dehumidification Rate	Cooling	Rated	l/h	1.1	1.3	1.8	2.5
	Heating	Rated	l/h	3.3	4.7	6.9	9.8
Running Current	Cooling	Max	A	6.0	6.0	9.0	14.0
	Heating	Max	A	4.0	4.7	7.1	10.4
Starting Current	Max	A	7.0	7.0	9.5	14.0	
Power Supply	Cooling/Heating	Rated	A	3.3 / 4.0	4.7 / 4.7	6.9 / 7.1	9.8 / 10.4
Circuit Breaker			∅ / V / Hz	1 / 220-240 / 50	1 / 220-240 / 50	1 / 220-240 / 50	1 / 220-240 / 50
Power Supply Cable			N x mm <sup>2</sup>	3 x 1.0	3 x 1.0	3 x 1.5	3 x 2.5
Power & Transmission Cable			N x mm <sup>2</sup>	4 x 1.0	4 x 1.0	4 x 1.0	4 x 1.0
Dimension			mm	837 x 308 x 192	837 x 308 x 192	998 x 345 x 212	998 x 345 x 212
Net Weight			kg	9.9	9.9	12.8	13.6
Fan Motor Output			W	30	30	30	60
OUTDOOR				AC09BQ.UA3	AC12BQ.UA3	AC18BQ.UL2	AC24BQ.U24
Operation Range	Cooling	Min / Max	°CDB	-10 / 48	-10 / 48	-15 / 48	-15 / 48
	Heating	Min / Max	°CDB	-10 / 24	-10 / 24	-10 / 24	-10 / 24
Sound Pressure	Cooling	High	dB(A)	48	48	53	53
	Heating	High	dB(A)	50	50	55	54
Sound Power	Cooling	High	dB(A)	65	65	65	70
	Heating	High	dB(A)	27	27	35	50
Air Flow Rate	Cooling	High	m <sup>3</sup> /min	27	27	35	50
	Length (Odu/Idu)	Min / Max	m	3 / 15	3 / 15	3 / 20	3 / 30
Piping	Elevation (Odu/Idu)	Max	m	7	7	10	15
	Liquid	OD(Outside)	mm (inch)	6.35 (1/4)	6.35 (1/4)	6.35 (1/4)	6.35 (1/4)
Piping Connection	Gas	OD(Outside)	mm (inch)	9.52 (3/8)	9.52 (3/8)	12.7 (1/2)	15.88 (5/8)
	Drain	OD(Outside)	mm (inch)	21.5 (0.85)	21.5 (0.85)	21.5 (0.85)	21.5 (0.85)
Refrigerant	Type			R32	R32	R32	R32
	Charge at 7.5m		g	700	700	1000	1100
	t-CO <sub>2</sub> eq		g	0.47	0.47	0.68	0.74
	Additional charge		g/m	20	20	20	20
Fan Motor Output			W	675	675	675	675
Compressor Type				Twin Rotary	Twin Rotary	Twin Rotary	Twin Rotary
Net Weight			kg	25.1	25.1	34.4	46.0
Dimension			mm	717 x 483 x 230	717 x 483 x 230	770 x 545 x 288	870 x 650 x 330

\* This product contains Fluorinated greenhouse gases (R32).  
 \*\* S : Sleep / L : Low / M : Medium / H : High  
 \*\*\* Specification, design and feature are subject to change without prior notice.

# ARTCOOL SILVER



NEW



Dual Inverter COMPRESSOR  
**EUROVENT CERTIFIED PERFORMANCE**  
 LG participates in the ECP programme for EUROVENT AC program. Check ongoing validity of certification : [www.eurovent-certification.com](http://www.eurovent-certification.com)

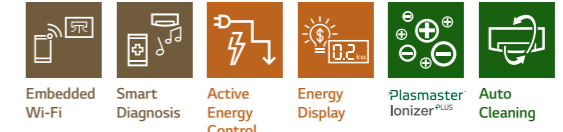

### • Single Combination

UNIT				9K	12K	18K
INDOOR				AC09SQ.NSJ	AC12SQ.NSJ	AC18SQ.NSK
Capacity	Cooling	Min/Rated/Max	W	890 / 2500 / 3700	890 / 3500 / 4040	900 / 5000 / 5500
	Heating +7°C	Min/Rated/Max	W	890 / 3300 / 4100	890 / 4000 / 5100	900 / 5800 / 6400
Power Input	Heating -7°C	Rated	W	2600	3000	4200
	Cooling	Rated	W	656	1080	1562
EER	Heating +7°C	Rated	W/W	800	1050	1611
	Cooling	Rated	W/W	3.81	3.24	3.20
S.E.E.R.				7.0	6.6	7.0
P design C			kW	2.5	3.5	5.0
COP			W/W	4.13	3.81	3.60
S.C.O.P.				4.0	4.0	4.3
P design H			kW	2.5	2.5	3.9
Energy Label	Cooling (A++ to E Scale)			A++	A++	A++
	Heating (A++ to E Scale)			A+	A+	A+
Annual Energy Consumption	Cooling		kWh	125	186	250
	Heating		kWh	875	875	1270
Sound Pressure	Cooling	S / L / M / H	dB(A)	19 / 27 / 35 / 41	19 / 27 / 35 / 41	31 / 34 / 39 / 44
	Heating	L / M / H	dB(A)	27 / 35 / 41	27 / 35 / 41	34 / 39 / 44
Sound Power	Cooling	H	dB(A)	59	59	60
	Heating	L / M / H	m <sup>3</sup> /min	3.0 / 4.2 / 7.5 / 10.0	3.0 / 4.2 / 7.5 / 10.0	8.0 / 10.5 / 13.0 / 14.5
Air Flow Rate	Cooling	Max (Power)	m <sup>3</sup> /min	12.5	12.5	15.5
	Heating	L / M / H	m <sup>3</sup> /min	5.6 / 7.2 / 10.0	5.6 / 7.2 / 10.0	11.0 / 13.5 / 16.0
Dehumidification Rate	Cooling	Rated	l/h	1.1	1.3	1.8
	Heating	Rated	l/h	3.3	4.7	6.9
Running Current	Cooling	Max	A	6.0	6.0	9.0
	Heating	Max	A	4.0	4.7	7.1
Starting Current	Max	A	7.0	7.0	9.5	
Power Supply	Cooling/Heating	Rated	A	3.3 / 4.0	4.7 / 4.7	6.9 / 7.1
Circuit Breaker			∅ / V / Hz	1 / 220-240 / 50	1 / 220-240 / 50	1 / 220-240 / 50
Power Supply Cable			N x mm <sup>2</sup>	3 x 1.0	3 x 1.0	3 x 1.5
Power & Transmission Cable			N x mm <sup>2</sup>	4 x 1.0 (Including Earth)	4 x 1.0 (Including Earth)	4 x 1.0 (Including Earth)
Dimension			mm	837 x 308 x 192	837 x 308 x 192	998 x 345 x 212
Net Weight			kg	8.7	8.7	11.9
Fan Motor Output			W	30	30	30
OUTDOOR				AC09BQ.UA3	AC12BQ.UA3	AC18BQ.UL2
Operation Range	Cooling	Min / Max	°CDB	-10 / 48	-10 / 48	-15 / 48
	Heating	Min / Max	°CDB	-10 / 24	-10 / 24	-10 / 24
Sound Pressure	Cooling	High	dB(A)	48	48	53
	Heating	High	dB(A)	50	50	55
Sound Power	Cooling	High	dB(A)	65	65	65
	Heating	High	dB(A)	27	27	35
Air Flow Rate	Cooling	High	m <sup>3</sup> /min	27	27	35
	Length (Odu/Idu)	Min / Max	m	3 / 15	3 / 15	3 / 20
Piping	Elevation (Odu/Idu)	Max	m	7	7	10
	Liquid	OD(Outside)	mm (inch)	6.35 (1/4)	6.35 (1/4)	6.35 (1/4)
Piping Connection	Gas	OD(Outside)	mm (inch)	9.52 (3/8)	9.52 (3/8)	12.7 (1/2)
	Drain	OD(Outside)	mm (inch)	21.5 (0.85)	21.5 (0.85)	21.5 (0.85)
Refrigerant	Type			R32	R32	R32
	Charge at 7.5m		g	700	700	1000
	t-CO <sub>2</sub> eq		g	0.47	0.47	0.68
	Additional charge		g/m	20	20	20
Fan Motor Output			W	675	675	675
Compressor Type				Twin Rotary	Twin Rotary	Twin Rotary
Net Weight			kg	25.1	25.1	34.4
Dimension			mm	717 x 483 x 230	717 x 483 x 230	770 x 545 x 288

\* This product contains Fluorinated greenhouse gases (R32).  
 \*\* S : Sleep / L : Low / M : Medium / H : High  
 \*\*\* Specification, design and feature are subject to change without prior notice.



LG participates in the ECP programme for EUROVENT AC program. Check ongoing validity of certification : [www.eurovent-certification.com](http://www.eurovent-certification.com)

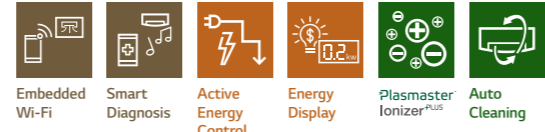

### • Single Combination

UNIT		9K		12K		18K		24K	
INDOOR		DC09RQ.NSJ		DC12RQ.NSJ		DC18RQ.NSK		DC24RQ.NSK	
Capacity	Cooling	Min / Rated / Max	W	890 / 2500 / 3700	890 / 3500 / 4040	900 / 5000 / 5500	900 / 6600 / 7420		
	Heating +7°C	Min / Rated / Max	W	890 / 3200 / 5000	890 / 4000 / 6000	900 / 5800 / 6400	900 / 7500 / 8640		
	Heating -7°C	Rated	W	3200	3500	4200	4850		
Power Input	Cooling	Rated	W	572	933	1562	2164		
	Heating +7°C	Rated	W	711	976	1611	2238		
EER			W/W	4.37	3.75	3.20	3.05		
	S.E.E.R.			7.9	7.6	7.0	6.9		
P design C			kW	2.5	3.5	5.0	6.6		
COP			W/W	4.5	4.1	3.60	3.35		
S.C.O.P.				4.6	4.6	4.3	4.2		
P design H			kW	2.8	2.9	3.9	5.0		
Energy Label	Cooling (A++ to E Scale)			A++	A++	A++	A++		
	Heating (A++ to E Scale)			A++	A++	A+	A+		
Annual Energy Consumption	Cooling		kWh	111	161	250	335		
	Heating		kWh	852	883	1270	1628		
Sound Pressure	Cooling	S / L / M / H	dBA	19 / 27 / 37 / 42	19 / 27 / 37 / 42	31 / 34 / 39 / 44	31 / 34 / 42 / 47		
	Heating	L / M / H	dBA	27 / 37 / 42	27 / 37 / 42	34 / 39 / 44	34 / 42 / 47		
Sound Power	Cooling	H	dBA	60	60	60	65		
		S / L / M / H	m <sup>3</sup> /min	3.5 / 5.5 / 9.0 / 11.0	3.5 / 5.5 / 9.0 / 11.0	8.0 / 10.5 / 13.0 / 14.5	8.0 / 10.5 / 13.1 / 16.1		
Air Flow Rate	Cooling	Max (Power)	m <sup>3</sup> /min	13.0	13.0	15.5	20.0		
	Heating	L / M / H	m <sup>3</sup> /min	6.5 / 9.0 / 11.0	6.5 / 9.0 / 11.0	11.0 / 13.5 / 16.0	10.5 / 13.1 / 16.1		
Dehumidification Rate			l/h	1.1	1.3	1.8	2.5		
		Rated	A	2.5	4.0	6.9	9.8		
Running Current	Cooling	Max	A	6.0	6.0	9.0	14.0		
		Rated	A	3.2	4.3	7.1	10.4		
	Heating	Max	A	7.0	7.0	9.5	14.0		
Starting Current	Cooling / Heating	Rated	A	2.5 / 3.2	4.0 / 4.3	6.9 / 7.1	9.8 / 10.4		
Power Supply			∅ / V / Hz	1 / 220-240 / 50	1 / 220-240 / 50	1 / 220-240 / 50	1 / 220-240 / 50		
Circuit Breaker			A	15	15	20	25		
Power Supply Cable			N x mm <sup>2</sup>	3 x 1.0	3 x 1.0	3 x 1.5	3 x 2.5		
Power & Transmission Cable			N x mm <sup>2</sup>	4 x 1.0	4 x 1.0	4 x 1.0	4 x 1.0		
Dimension			mm	837 x 308 x 189	837 x 308 x 189	998 x 345 x 210	998 x 345 x 210		
Net Weight			kg	9.1	9.1	11.9	11.9		
Fan Motor Output			W	30	30	30	60		
OUTDOOR		DC09RQ.UL2		DC12RQ.UL2		DC18RQ.UL2		DC24RQ.U24	
Operation Range	Cooling	Min / Max	°CDB	-15 / 48	-15 / 48	-15 / 48	-15 / 48		
	Heating	Min / Max	°CDB	-15 / 24	-15 / 24	-10 / 24	-10 / 24		
Sound Pressure	Cooling	High	dBA	49	49	53	53		
	Heating	High	dBA	51	51	55	54		
Sound Power	Cooling	High	dBA	65	65	65	70		
Air Flow Rate	Cooling	High	m <sup>3</sup> /min	35	35	35	50		
Piping	Length (Odu/Idu)	Min / Max	m	3 / 20	3 / 20	3 / 20	3 / 30		
	Elevation (Odu/Idu)	Max	m	10	10	10	15		
Piping Connection	Liquid	OD(Outside)	mm (inch)	6.35 (1/4)	6.35 (1/4)	6.35 (1/4)	6.35 (1/4)		
	Gas	OD(Outside)	mm (inch)	9.52 (3/8)	9.52 (3/8)	12.7 (1/2)	15.88 (5/8)		
	Drain	OD(Outside)	mm (inch)	21.5 (0.85)	21.5 (0.85)	21.5 (0.85)	21.5 (0.85)		
Refrigerant	Type			R32	R32	R32	R32		
	Charge at 7.5m		g	800	800	1000	1100		
	t-CO <sub>2</sub> eq			0.54	0.54	0.68	0.74		
Additional charge			g/m	20	20	20	20		
	GWP			675	675	675	675		
Fan Motor Output			W	43	43	43	85		
Compressor Type				Twin Rotary	Twin Rotary	Twin Rotary	Twin Rotary		
Net Weight			kg	34.1	34.1	34.4	46.0		
Dimension			mm	770 x 545 x 288	770 x 545 x 288	770 x 545 x 288	870 x 650 x 330		

\* This product contains Fluorinated greenhouse gases (R32).

\*\* S : Sleep / L : Low / M : Medium / H : High

\*\*\* Specification, design and feature are subject to change without prior notice.



LG participates in the ECP programme for EUROVENT AC program. Check ongoing validity of certification : [www.eurovent-certification.com](http://www.eurovent-certification.com)



### • Single Combination

UNIT		9K		12K		18K		24K	
INDOOR		PC09SQ.NSJ		PC12SQ.NSJ		PC18SQ.NSK		PC24SQ.NSK	
Capacity	Cooling	Min / Rated / Max	W	890 / 2500 / 3700	890 / 3500 / 4040	900 / 5000 / 5500	900 / 6600 / 7420		
	Heating +7°C	Min / Rated / Max	W	890 / 3300 / 4100	890 / 4000 / 5100	900 / 5800 / 6400	900 / 7500 / 8640		
	Heating -7°C	Rated	W	2600	3000	4200	4850		
Power Input	Cooling	Rated	W	656	1080	1562	2164		
	Heating +7°C	Rated	W	800	1050	1611	2238		
EER			W/W	3.81	3.24	3.20	3.05		
	S.E.E.R.			7.0	6.6	7.0	6.9		
P design C			kW	2.5	3.5	5.0	6.6		
COP			W/W	4.13	3.81	3.60	3.35		
S.C.O.P.				4.0	4.0	4.3	4.2		
P design H			kW	2.5	2.5	3.9	5.0		
Energy Label	Cooling (A++ to E Scale)			A++	A++	A++	A++		
	Heating (A++ to E Scale)			A+	A+	A+	A+		
Annual Energy Consumption	Cooling		kWh	125	186	250	335		
	Heating		kWh	875	875	1270	1628		
Sound Pressure	Cooling	S / L / M / H	dBA	19 / 27 / 35 / 41	19 / 27 / 35 / 41	31 / 34 / 39 / 44	31 / 34 / 42 / 47		
	Heating	L / M / H	dBA	27 / 35 / 41	27 / 35 / 41	34 / 39 / 44	34 / 42 / 47		
Sound Power	Cooling	High	dBA	59	59	60	65		
		S / L / M / H	m <sup>3</sup> /min	3.0 / 4.2 / 7.5 / 10.0	3.0 / 4.2 / 7.5 / 10.0	8.0 / 10.5 / 13.0 / 14.5	8.0 / 10.5 / 13.1 / 16.1		
Air Flow Rate	Cooling	Max (Power)	m <sup>3</sup> /min	12.5	12.5	15.5	20.0		
	Heating	L / M / H	m <sup>3</sup> /min	5.6 / 7.2 / 10.0	5.6 / 7.2 / 10.0	11.0 / 13.5 / 16.0	10.5 / 13.1 / 16.1		
Dehumidification Rate			l/h	1.1	1.3	1.8	2.5		
		Rated	A	3.3	4.7	6.9	9.8		
Running Current	Cooling	Max	A	6.0	6.0	9.0	14.0		
		Rated	A	4.0	4.7	7.1	10.4		
	Heating	Max	A	7.0	7.0	9.5	14.0		
Starting Current	Cooling / Heating	Rated	A	3.3 4.0	4.7 4.7	6.9 7.1	9.8 / 10.4		
Power Supply			∅ / V / Hz	1 / 220-240 / 50	1 / 220-240 / 50	1 / 220-240 / 50	1 / 220-240 / 50		
Circuit Breaker			A	15	15	20	25		
Power Supply Cable			N x mm <sup>2</sup>	3 x 1.0	3 x 1.0	3 x 1.5	3 x 2.5		
Power & Transmission Cable			N x mm <sup>2</sup>	4 x 1.0	4 x 1.0	4 x 1.0	4 x 1.0		
Dimension			mm	837 x 308 x 189	837 x 308 x 189	998 x 345 x 210	998 x 345 x 210		
Net Weight			kg	8.7	8.7	11.9	11.9		
Fan Motor Output			W	30	30	30	60		
OUTDOOR		PC09SQ.UA3		PC12SQ.UA3		PC18SQ.UL2		PC24SQ.U24	
Operation Range	Cooling	Min / Max	°CDB	-10 / 48	-10 / 48	-15 / 48	-15 / 48		
	Heating	Min / Max	°CDB	-10 / 24	-10 / 24	-10 / 24	-10 / 24		
Sound Pressure	Cooling	High	dBA	48	48	53	53		
	Heating	High	dBA	50	50	55	54		
Sound Power	Cooling	High	dBA	65	65	65	70		
Air Flow Rate	Cooling	High	m <sup>3</sup> /min	27	27	35	50		
Piping	Length (Odu/Idu)	Min / Max	m	3 15	3 15	3 20	3 / 30		
	Elevation (Odu/Idu)	Max	m	7	7	10	15		
Piping Connection	Liquid	OD(Outside)	mm (inch)	6.35 (1/4)	6.35 (1/4)	6.35 (1/4)	6.35 (1/4)		
	Gas	OD(Outside)	mm (inch)	9.52 (3/8)	9.52 (3/8)	12.7 (1/2)	15.88 (5/8)		
	Drain	OD(Outside)	mm (inch)	21.5 (0.85)	21.5 (0.85)	21.5 (0.85)	21.5 (0.85)		
Refrigerant	Type			R32	R32	R32	R32		
	Charge at 7.5m		g	700	700	1000	1100		
	t-CO <sub>2</sub> eq			0.47	0.47	0.68	0.74		
Additional charge			g/m	20	20	20	20		
	GWP			675	675	675	675		
Fan Motor Output			W	43	43	43	85		
Compressor Type				Twin Rotary	Twin Rotary	Twin Rotary	Twin Rotary		
Net Weight			kg	25.1	25.1	34.4	46.0		
Dimension			mm	717 x 483 x 230	717 x 483 x 230	770 x 545 x 288	870 x 650 x 330		

\* This product contains Fluorinated greenhouse gases (R32).

\*\* S : Sleep / L : Low / M : Medium / H : High

\*\*\* Specification, design and feature are subject to change without prior notice.

# STANDARD



LG participates in the ECP programme for EUROVENT AC program. Check ongoing validity of certification: [www.eurovent-certification.com](http://www.eurovent-certification.com)

Smart Diagnosis	Active Energy Control	Energy Display	Auto Cleaning	Jet Cool	2 Way Swing (9k, 12k)	4 Way Swing (18k, 24k)	Fast Heating
Gold Fin™	Comfort Air	Low Noise 19dB (9k, 12k)	Silence Mode	Quick & Easy Installation			

## • Single Combination

UNIT		9K		12K		18K		24K	
INDOOR		S09EQ.NSJ		S12EQ.NSJ		S18EQ.NSK		S24EQ.NSK	
Capacity	Cooling	Min / Rated / Max	W	890 / 2500 / 3700	890 / 3500 / 4040	900/5000/5500	900 / 6600 / 7420		
	Heating +7°C	Min / Rated / Max	W	890 / 3300 / 4100	890 / 4000 / 5100	900/5800/6400	900 / 7500 / 8640		
Power Input	Cooling	Rated	W	656	1080	1562	2164		
	Heating +7°C	Rated	W	800	1050	1611	2238		
EER			W/W	3.81	3.24	3.20	3.05		
S.E.E.R.				7.0	6.6	7.0	6.9		
P design C			kW	2.5	3.5	5.0	6.6		
COP			W/W	4.13	3.81	3.60	3.35		
S.C.O.P.				4.0	4.0	4.3	4.2		
P design H			kW	2.5	2.5	3.9	5.0		
Energy Label	Cooling (A++ to E Scale)			A++	A++	A++	A++		
	Heating (A++ to E Scale)			A+	A+	A+	A+		
Annual Energy Consumption	Cooling		kWh	125	186	250	335		
	Heating		kWh	875	875	1270	1628		
Sound Pressure	Cooling	S / L / M / H	dBA	19 / 27 / 35 / 41	19 / 27 / 35 / 41	31 / 34 / 39 / 44	31 / 34 / 42 / 47		
	Heating	L / M / H	dBA	27 / 35 / 41	27 / 35 / 41	34 / 39 / 44	34 / 42 / 47		
Sound Power	Cooling	High	dBA	59	59	60	65		
	Heating	S / L / M / H	m <sup>3</sup> /min	3.0 / 4.2 / 7.5 / 10.0	3.0 / 4.2 / 7.5 / 10.0	8.0 / 10.5 / 13.0 / 14.5	8.0 / 10.5 / 13.1 / 16.1		
Air Flow Rate	Cooling	Max (Power)	m <sup>3</sup> /min	12.5	12.5	15.5	20.0		
	Heating	L / M / H	m <sup>3</sup> /min	5.6 / 7.2 / 10.0	5.6 / 7.2 / 10.0	11.0 / 13.5 / 16.0	10.5 / 13.1 / 16.1		
Dehumidification Rate	Cooling	Rated	l/h	1.1	1.3	1.8	2.5		
	Heating	Max	A	3.3	4.7	6.9	9.8		
Running Current	Cooling	Rated	A	6.0	6.0	9.0	14.0		
	Heating	Max	A	4.0	4.7	7.1	10.4		
Starting Current	Cooling / Heating	Rated	A	7.0	7.0	9.5	14.0		
Power Supply			Ø / V / Hz	1 / 220-240 / 50	1 / 220-240 / 50	1 / 220-240 / 50	1 / 220-240 / 50		
Circuit Breaker			A	15	15	20	25		
Power Supply Cable			N x mm <sup>2</sup>	3 x 1.0	3 x 1.0	3 x 1.5	3 x 2.5		
Power & Transmission Cable			N x mm <sup>2</sup>	4 x 1.0	4 x 1.0	4 x 1.0	4 x 1.0		
Dimension			mm	837 x 308 x 189	837 x 308 x 189	998 x 345 x 210	998 x 345 x 210		
Net Weight			kg	8.7	8.7	11.9	11.9		
Fan Motor Output			W	30	30	30	60		
OUTDOOR		S09EQ.UA3		S12EQ.UA3		S18EQ.U2		S24EQ.U24	
Operation Range	Cooling	Min / Max	°CDB	-10 / 48	-10 / 48	-15 / 48	-15 / 48		
	Heating	Min / Max	°CDB	-10 / 24	-10 / 24	-10 / 24	-10 / 24		
Sound Pressure	Cooling	High	dBA	48	48	53	53		
	Heating	High	dBA	50	50	55	54		
Sound Power	Cooling	High	dBA	65	65	65	70		
	Heating	High	dBA	27	27	35	50		
Air Flow Rate	Cooling	High	m <sup>3</sup> /min	27	27	35	50		
	Length (Odu/Idu)	Min / Max	m	3 / 15	3 / 15	3 / 20	3 / 30		
Piping	Elevation (Odu/Idu)	Max	m	7	7	10	15		
	Liquid	OD(Outside)	mm (inch)	6.35 (1/4)	6.35 (1/4)	6.35 (1/4)	6.35 (1/4)		
Piping Connection	Gas	OD(Outside)	mm (inch)	9.52 (3/8)	9.52 (3/8)	12.7 (1/2)	15.88 (5/8)		
	Drain	OD(Outside)	mm (inch)	21.5 (0.85)	21.5 (0.85)	21.5 (0.85)	21.5 (0.85)		
Refrigerant	Type			R32	R32	R32	R32		
	Charge at 7.5m		g	700	700	1000	1100		
	Additional charge		t-CO <sub>2</sub> eq	0.47	0.47	0.68	0.74		
	GWP		g/m	20	20	20	20		
Fan Motor Output			W	675	675	675	675		
Compressor Type				43	43	43	85		
Net Weight			kg	Twin Rotary	Twin Rotary	Twin Rotary	Twin Rotary		
Dimension			mm	25.1	25.1	34.4	46.0		
				717 x 483 x 230	717 x 483 x 230	770 x 545 x 288	870 x 650 x 330		

\* This product contains Fluorinated greenhouse gases (R32).

\*\* S : Sleep / L : Low / M : Medium / H : High

\*\*\* Specification, design and feature are subject to change without prior notice.

# INDOOR UNIT

## H09AP.NSM / H12AP.NSM

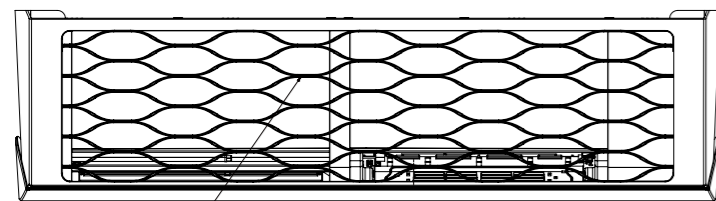

(Unit: mm)

Item No.	Part Name	Remark
1	Front Panel	
2	Air Suction Grille	
3	Knockout Hole	For pipe and cable

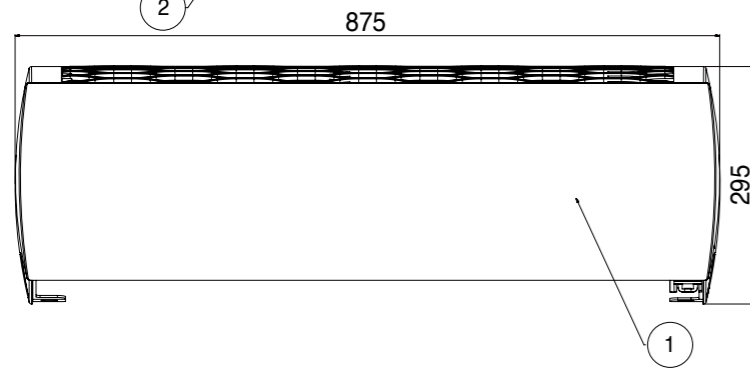

## AC09BQ.NSJ / AC12BQ.NSJ / AC09SQ.NSJ / AC12SQ.NSJ

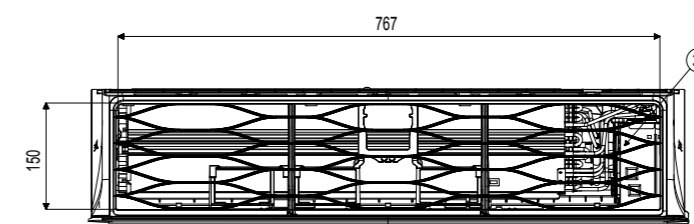

(Unit: mm)

Item No.	Part Name	Remark
1	Front Panel	
2	Display & Signal Receiver	
3	Air Filter	
4	Knockout hole	For pipe and cable

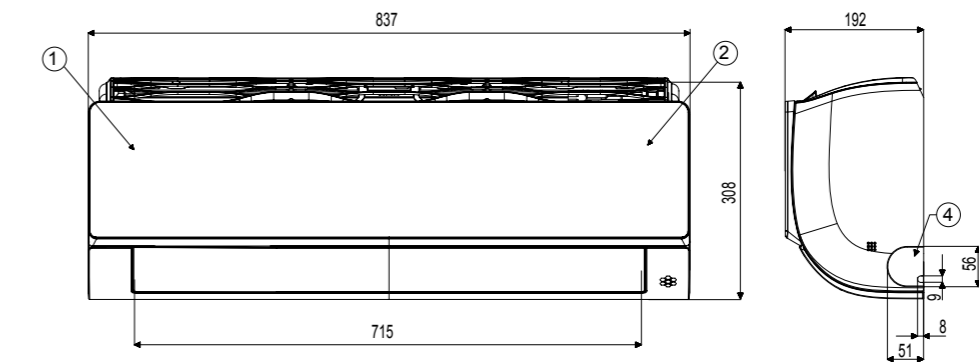

## A09FR.NSF/A12FR.NSF

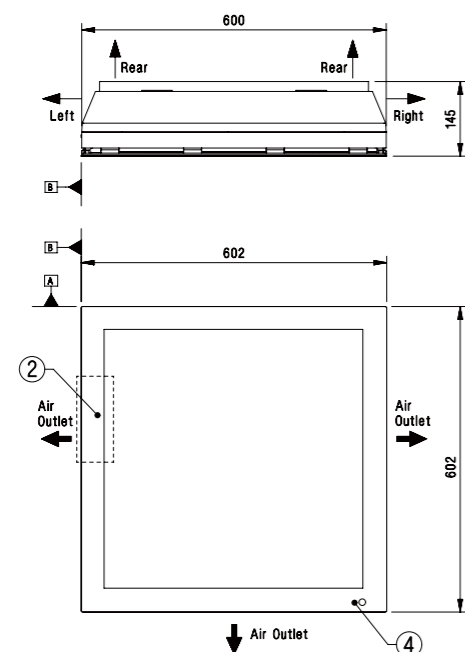

(Unit: mm)

Item No.	Part Name	Description
1	Refrigerant/Drain pipe and cable routing hole	Knock-out type
2	Terminal Block for Power supply and communication	inside of front panel
3	Corner Cover	-
4	Remote Controller Signal Receiver	for wireless type

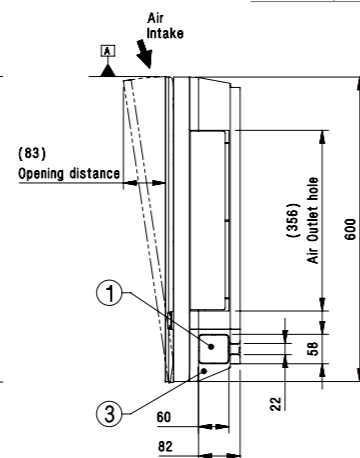

## AC18BQ.NSK / AC24BQ.NSK / AC18SQ.NSK

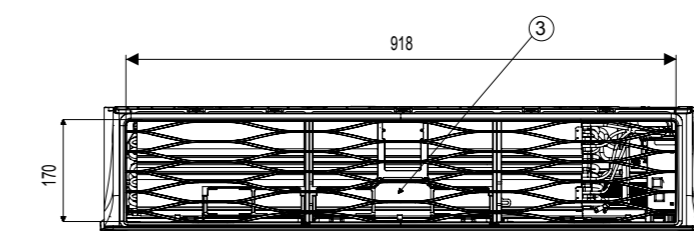

(Unit: mm)

Item No.	Part Name	Remark
1	Front Panel	
2	Display & Signal Receiver	
3	Air Suction Filter	
4	Installation Plate	

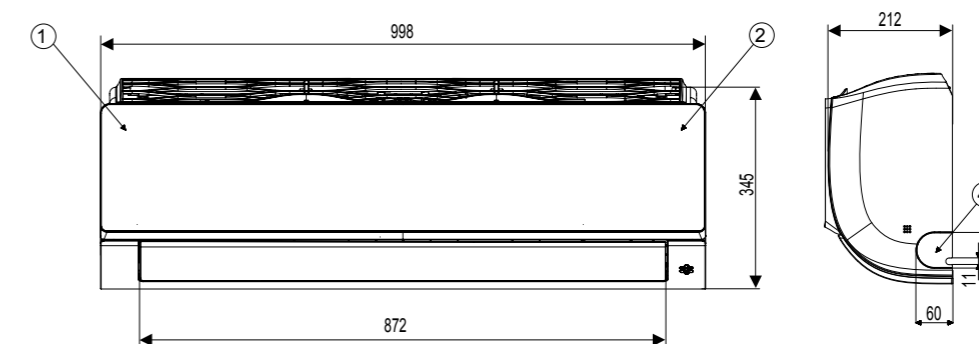

# INDOOR UNIT

## DC09RQ.NSJ / PC12SQ.NSJ / PC09SQ.NSJ / PC12SQ.NSJ / S09EQ.NSJ / S12EQ.NSJ

(Unit : mm)

Item No.	Part Name	Remark
1	Front Panel	
2	Display & Signal Receiver	Hidden
3	Air Filter	
4	Knockout hole	For pipe and cable

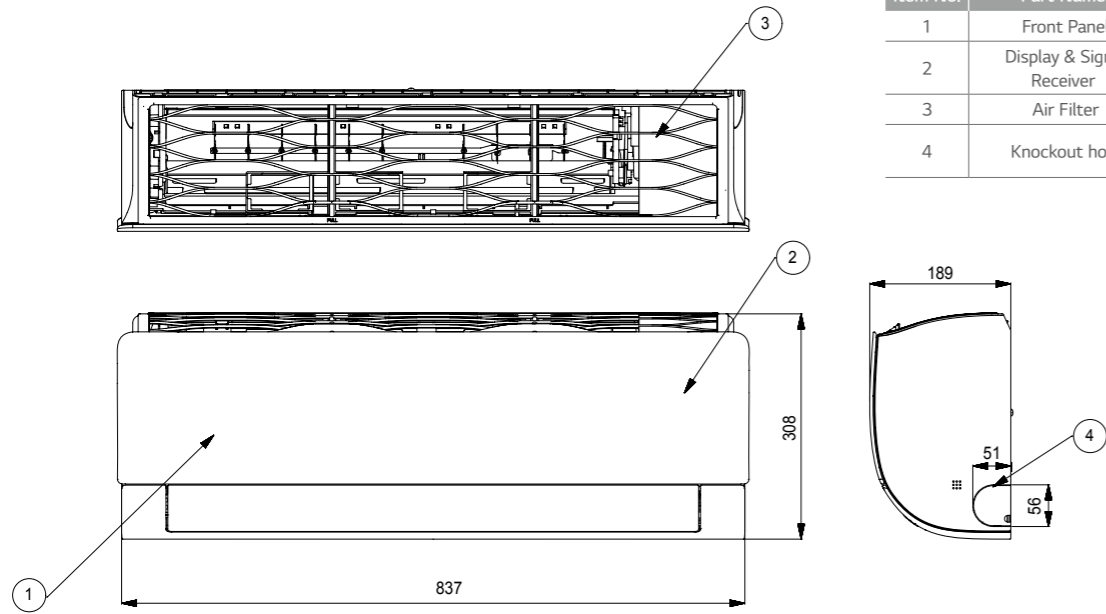

## DC18RQ.NSK / DC24RQ.NSK / PC18SQ.NSK / PC24SQ.NSK / S18EQ.NSK / S24EQ.NSK

(Unit : mm)

Item No.	Part Name	Remark
1	Front Panel	
2	Display & Signal Receiver	Hidden
3	Air Filter	
4	Knockout hole	For pipe and cable

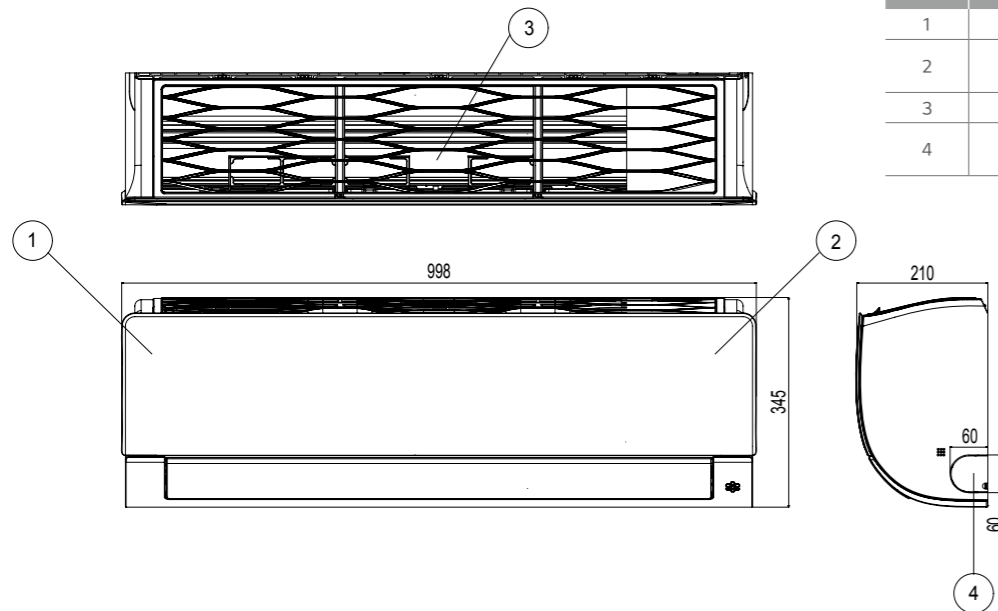

# INDOOR UNIT

AC09BQ.UA3 / AC12BQ.UA3 / AC09SQ.UA3 / AC12SQ.UA3 / DC09RQ.UA3  
DC12RQ.UA3 / PC09SQ.UA3 / PC12SQ.UA3 / S09EQ.UA3 / S12EQ.UA3

(Unit: mm)

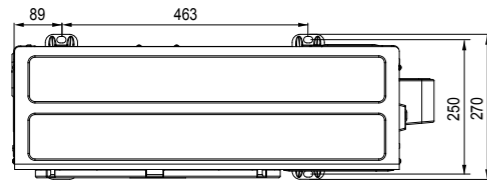

Item No.	Part Name
1	Air Outlet
2	Control Box
3	Power and Communication Cable Hole
4	Service Valve Cover
5	Gas Pipe Connection
6	Liquid Pipe Connection

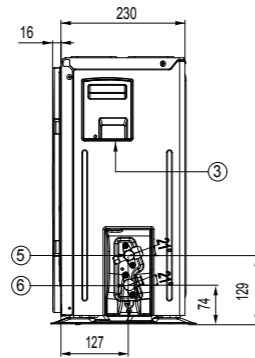
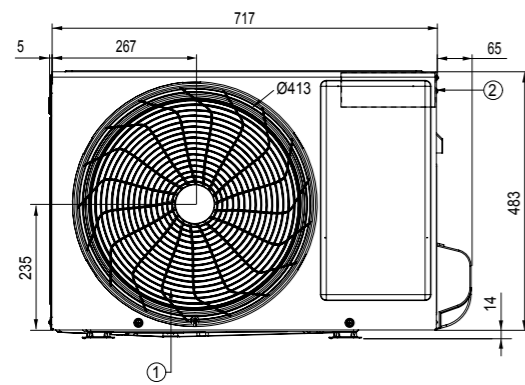

H09AP.U24 / H12AP.U24 / AC24BQ.UL2 / DC24RQ.UL2 / PC24SQ.UL2 / S24EQ.UL2

(Unit: mm)

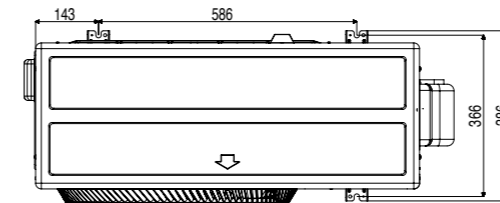

Item No.	Part Name
1	Air Outlet
2	Control Box
3	Power and Communication Cable Hole
4	Service Valve Cover
5	Gas Pipe Connection
6	Liquid Pipe Connection

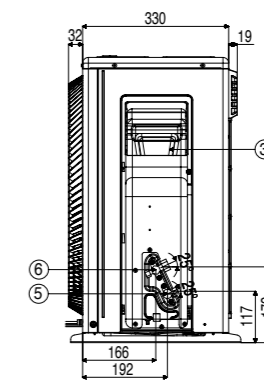
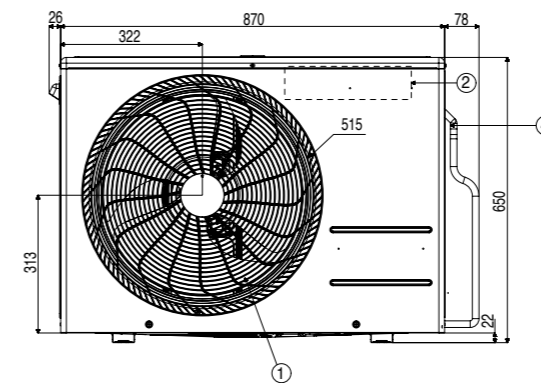

AC18BQ.UL2 / AC18SQ.UL2 / DC18RQ.UL2 / PC18SQ.UL2 / S18EQ.UL2

(Unit: mm)

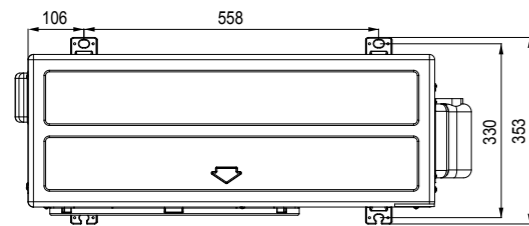

Item No.	Part Name
1	Air Outlet
2	Control Box
3	Power and Communication Cable Hole
4	Service Valve Cover
5	Gas Pipe Connection
6	Liquid Pipe Connection

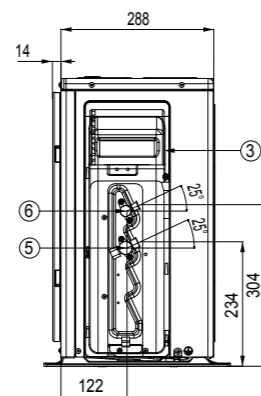
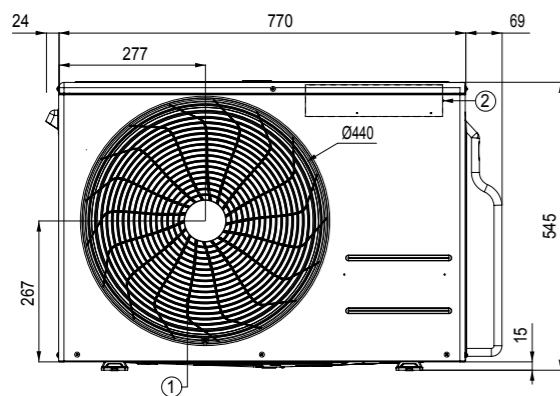

\* This product contains Fluorinated greenhouse gases (R410A).

# ACCESSORIES

		PRESTIGE	ARTCOOL GALLERY	ARTCOOL	DELUXE	STANDARD PLUS	STANDARD
Wired Remote Controller	5k					Y	
	7k			Y	Y	Y	-
	9k	Y	-	Y	Y	Y	-
	12k	Y	-	Y	Y	Y	-
	15k					Y	
	18k			Y	Y	Y	-
PI 485	5k					-	
	7k				Y*	-	-
	9k	-	-	-	Y*	-	-
	12k	-	-	-	Y*	-	-
	15k					-	
	18k				Y*	-	-
Dry Contact	5k					Y	
	7k			Y	Y	Y	-
	9k	Y	Y	Y	Y	Y	-
	12k	Y	Y	Y	Y	Y	-
	15k					Y	
	18k			Y	Y	Y	-
24k			Y	Y	Y	-	

\* Y: Available

\* When connected to Multi 14k & 16k Outdoor units, this may not be supported.

## Standard Wired Remote Controller

### • Standard III



PREMTB100 PREMTBB10

### • Standard II



PREMTB001 PREMTBB01

MODEL NAME	PREMTB100 PREMTBB10	PREMTB001 PREMTBB01
Operation Mode	On/Off, Fan Speed Control, Temperature Setting	
Mode Change	Cooling / Heating / Auto / Dehumidification / Fan	
Auto Swing / Vane Control	-	-
Reservation	Simple / Sleep / On, Off / Weekly / Holiday	
Time Display	-	-
Electrical Failure Compensation	-	-
Child Lock	-	-
Operation Status LED	-	-
Indoor Temperature Display	-	-
Wireless Remote Controller Receiver	-	-
Size (W x H x D, mm)	120 x 120 x 16	120 x 121 x 16
Backlight	-	-

\* Refer to each model PDB for applicable models.

## PI 485



PMNFP14A1

Power : Single phase AC 220V 50/60Hz

Max. no of the indoor units that can be connected: 64 UNITS

Model applied : RAC / Multi / Single / Therma V

\* Refer to each product PDB for applicable models

## Dry Contact



PDRYCB000

PDRYCB400



PDRYCB300

PDRYCB500

\* Refer to each product PDB for applicable models

MODEL	PDRYCB000	PDRYCB400	PDRYCB300	PDRYCB500
Contact Point	1 Control Point	2 Control Point	8 Control Point	Modbus RTU
Power Input	AC 220V from outside power source	DC 5V & 12V from indoor unit PCB	DC 5V & 12V from indoor unit PCB	DC 5V & 12 V from indoor unit PDB
Voltage / Non Voltage Input		•	•	
On / Off Control	•	•	•	•
Lock / Unlock	•	•	•	
Fan Speed Setting			•	•
Thermo Off		•	•	
Energy Saving		•		
Temperature Setting		•	•	•
Error Monitoring	•	•	•	•
Operation Monitoring	•	•	•	•

## Remote Controller



Prestige  
Artcool  
New Deluxe  
New Standard Plus  
Standard

BUTTON	DISPLAY SCREEN	DESCRIPTION
	-	To turn On / Off the air conditioner.
	88°	To adjust the desired room temperature in cooling, heating or auto changeover mode.
<b>COMFORT AIR</b>		To adjust the air flow to deflect wind.
<b>LIGHT OFF</b>	-	To set the brightness of the display on the indoor unit.
<b>MODE</b>		To select the cooling mode.
		To select the heating mode.
		To select the dehumidification mode.
		To select the fan mode.
<b>FAN SPEED</b>		To select the auto changeover / auto operation mode.
		To adjust the fan speed.
<b>ENERGY CTRL.</b>		To bring the effect of the power saving.
<b>JET MODE</b>		To change room temperature quickly.
		To adjust the air flow direction vertically or horizontally.
<b>ROOM TEMP</b>		To display the room temperature.
°C ↔ °F[5sec]		To change unit between °C and °F.
<b>SET/ CANCEL</b>	-	To set / cancel the functions and timer.
	-	To adjust time.
	-	To turn on / off air conditioner automatically.
	-	To cancel the timer settings.

# MULTI SPLIT











# LINE-UP

## R32 INDOOR / OUTDOOR UNIT



○ Single Only ○● Compatible ● Multi Only



KBTU/H		5	7	9	12	15	18	24
KW		1.5	2.1	2.6	3.5	4.2	5.3	7.0
Wall Mounted Unit	ARTCOOL Gallery  <b>NEW</b>			○● A09FR.NSF	○● A12AR.NSF			
	ARTCOOL Mirror 		● AM07BPNSJ	○● AC09BQ.NSJ	○● AC12BQ.NSJ		○● AC18BQ.NSK	○● AM24BPNSK
	ARTCOOL Silver  <b>NEW</b>			○● AC09SQ.NSJ	○● AC12SQ.NSJ		○● AC18SQ.NSK	
	Deluxe 		● DM07RP.NSJ	○● DC09RQ.NSJ	○● DC12RQ.NSJ		○● DC18RQ.NSK	○● DM24RP.NSK
	Standard Plus 		● PM05SP.NSJ	● PM07SP.NSJ	○● PC09SQ.NSJ	○● PC12SQ.NSJ	● PM15SP.NSJ	○● PC18SQ.NSK
Ceiling Mounted Cassette	1 Way Cassette 			● MT09R.NU1	● MT11R.NU1			
	4 Way Cassette 		● MT06R.NR0	● MT08R.NR0	○● CT09R.NR0	○● CT12R.NR0	○● CT18R.NQ0	○● CT24R.NP0
Ceiling Concealed Duct	Mid / High Static Pressure 						○● CM18R.N10	○● CM24R.N10
	Low Static Pressure 			○● CL09R.N20	○● CL12R.N20		○● CL18R.N20	○● CL24R.N30

KBTU/H	14	16	18	21	24	27	30
KW	4.1	4.7	5.3	6.2	7.0	7.9	8.8
Multi	 MU2R15.U40 2-port	 MU2R17.U40 2-port	 MU3R19.U40 3-port	 MU3R21.U40 3-port	 MU4R25.U40 4-port	 MU4R27.U40 4-port	 MU5R30.U40 5-port

\* ARTCOOL Gallery will be available from May, '19

## R410A INDOOR / OUTDOOR UNIT

KBTU/H		5	7	9	12	15	18	24
KW		1.5	2.1	2.6	3.5	4.2	5.3	7.0
Ceiling & Floor Convertible 				○● CV09.NE2	○● CV12.NE2			
Console 				○● CQ09.NA0	○● CQ12.NA0		○● CQ18.NA0	

KBTU/H	40	48	57
KW	11.7	14.1	16.7
Multi Piping 	MU5M40.U44 5-port		
Distribution Box 	FM40AH.U34 / FM41AH.U34 7-IDU	FM48AH.U34 / FM49AH.U34 8-IDU	FM56AH.U34 / FM57AH.U34 9-IDU

# FEATURE OVERVIEW

Category	R32 MULTI PIPING							R410A DB BOX TYPE				
	kBtu/h	14	16	18	21	24	27	30	40	46	48	57
kW	4.1	4.7	5.3	6.2	7.0	7.9	8.8	11.7	13.5	14.1	16.7	
Energy Efficiency	BLDC Comp. & Fan Motor	●	●	●	●	●	●	●	●	●	●	●
	Eurovent Certification	●	●	●	●	●	●	●	●	●	●	●
	Wide Louver Plus Fin	●	●	●	●	●	●	●	●	●	●	●
	Optimised Heat Exchanger Path	●	●	●	●	●	●	●	●	●	●	●
	Smart Load Control			●	●	●	●	●	●			
	Peak Current Control	●	●	●	●	●	●	●	●	●	●	●
	Standby Mode	●	●	●	●	●	●	●	●	●	●	●
	Mode Lock	●	●	●	●	●	●	●	●	●	●	●
	Twin Rotary Compressor	●	●	●	●	●	●	●	●	●	●	●
	Smart Sensor Pressure Control			●	●	●	●	●	●	●	●	●
Durability	Ocean Black Fin Heat Exchanger	●	●	●	●	●	●	●	●	●	●	
	Fast Cooling & Heating			●	●	●	●	●	●	●	●	
	Night Silent Operation	●	●	●	●	●	●	●	●	●	●	
	Wiring Error Check	●	●	●	●	●	●	●	●	●	●	
Comfort & Convenience	Monitoring PCB	●	●	●	●	●	●	●	●	●	●	
	LG MV	●	●	●	●	●	●	●	●	●	●	
	Forced Cooling Operation	●	●	●	●	●	●	●	●	●	●	

# KEY FEATURES

## PERFECT SOLUTION FOR MULTIPLE ROOMS



**Energy Efficiency | Extreme Durability | Comfort and Convenience**

LG Multi split system provides powerful, efficient cooling and heating with two, three, four, or up to nine indoor units operating of a single outdoor unit. LG's advanced inverter technology brings powerful performance while consuming less energy and it uses less space than installing individual single split systems. A variety of sleek and elegant indoor units to complement any décor are available in a full range of capacities for all room sizes. Installation is easy and it offers various convenient functions for easy maintenance.



# ENERGY EFFICIENCY

## ENERGY EFFICIENCY A+++ / A+

The advanced technologies of LG achieve the lowest energy consumption, especially SEER value regarding ErP regulation.

**World Class High Efficiency**

**SEER 8.5**

SEER / SCOP class (ErP regulation)		4.1	4.7	5.3	6.2	7.0	7.9	8.8
kW		4.1	4.7	5.3	6.2	7.0	7.9	8.8
SEER		8.5	7.8	8.5	8.5	8.2	8.0	8.2
		A+++	A++	A+++	A+++	A++	A++	A++
SCOP		4.2	4.2	4.2	4.2	4.2	4.2	4.2
		A+	A+	A+	A+	A+	A+	A+

- BLDC Inverter Twin Rotary Compressor
- Enhanced Heat Exchanger
- Smart Load Control
- Peak current control

## Enhanced Heat exchange by Wide Louver Plus Fin

Wide Louver Plus fin technology increases 11% of full load heating performance and 6% of COP compared to conventional fin. It can slow down frosting of heat exchanger and postpone the start of defrosting operation.

### • Heating Operation at Defrost Condition

It can slow down frosting of heat exchanger and postpone the start of defrosting operation

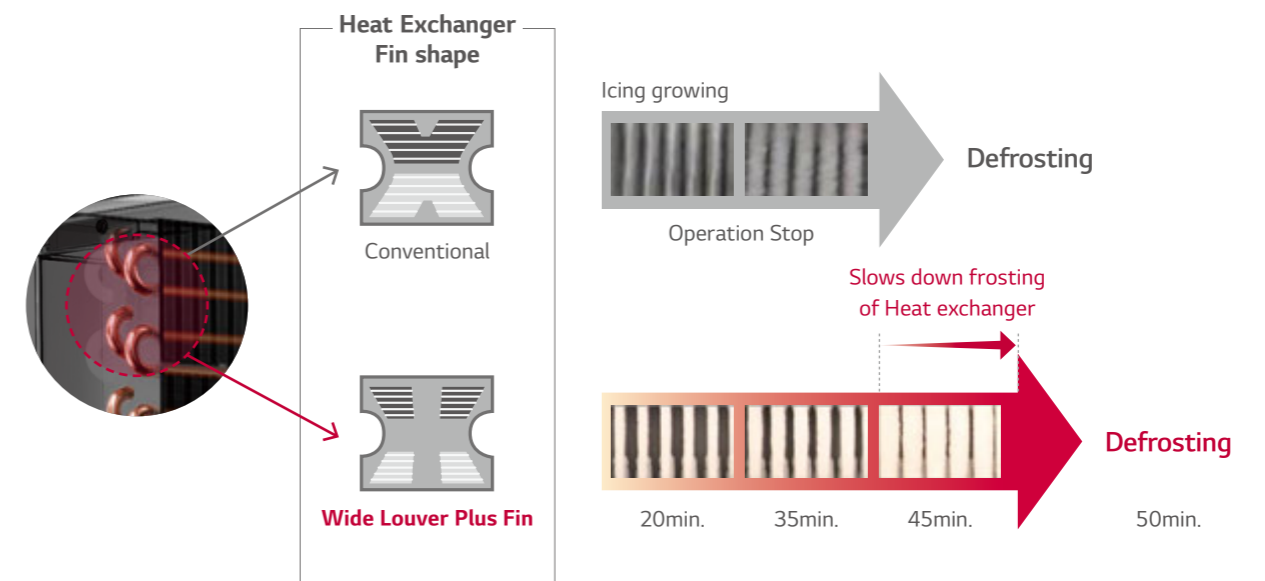

## Powerful BLDC (Brushless Direct Current Motor) Compressor

LG air conditioners are equipped with a BLDC Inverter Twin Rotary Compressor that uses a neodymium magnetic core. The compressor has high efficiency and superior reliability, because it is excellent in controlling the operating speed depending on the load. The compressor has improved efficiency compared to standard AC inverter products and optimized for changes of outdoor load. Especially it is optimized for seasonal efficiency.

### • Operation Range

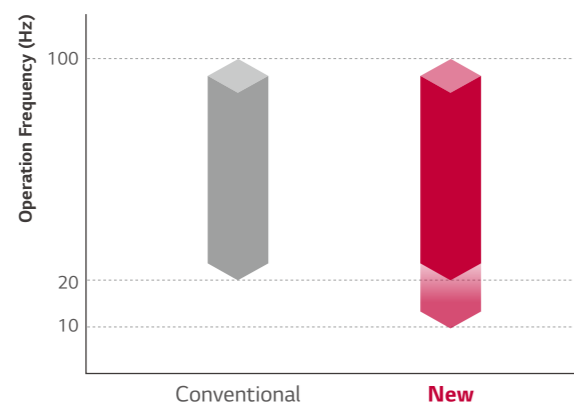

### • Motor Efficiency

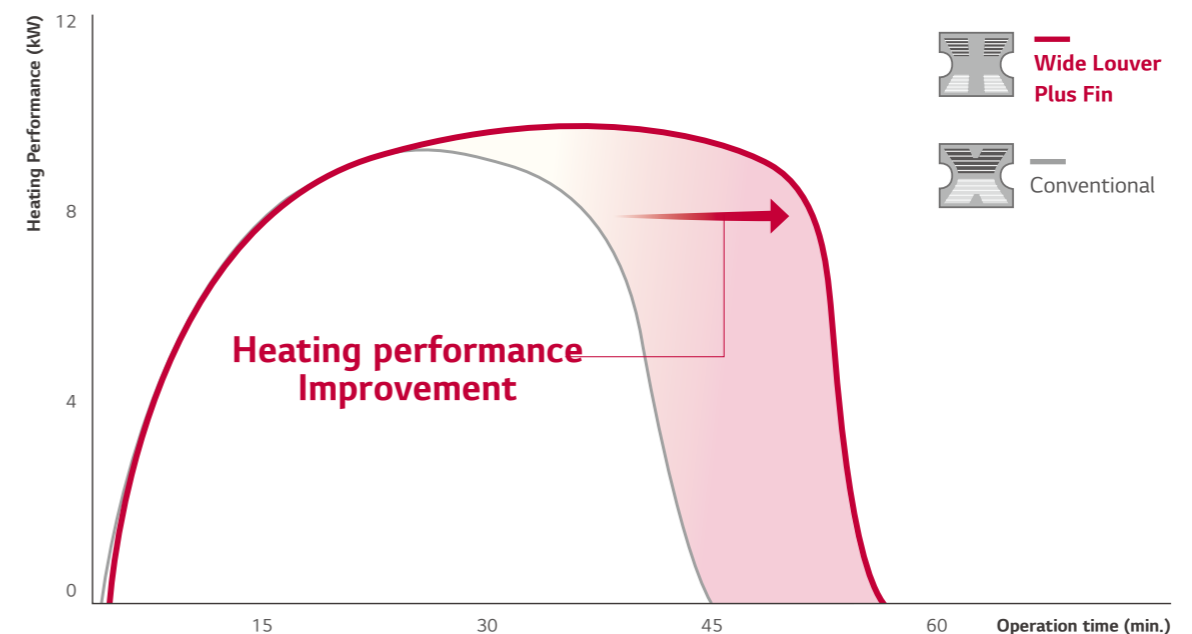
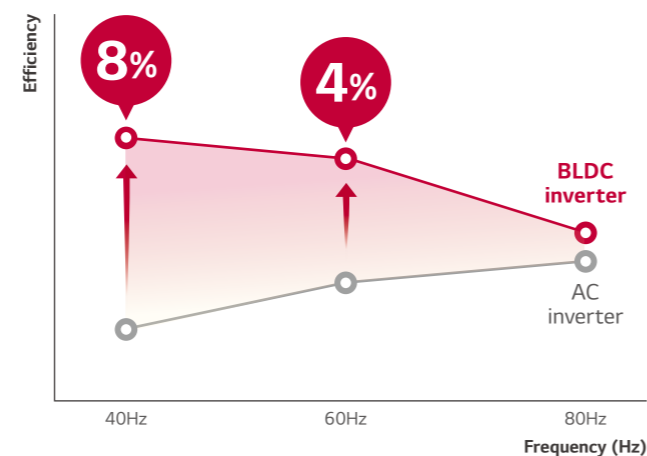

\* LG Internal test data

# ENERGY EFFICIENCY

## Smart Load Control

To save operation energy, it automatically controls the refrigerant temperature according to outside temperature.

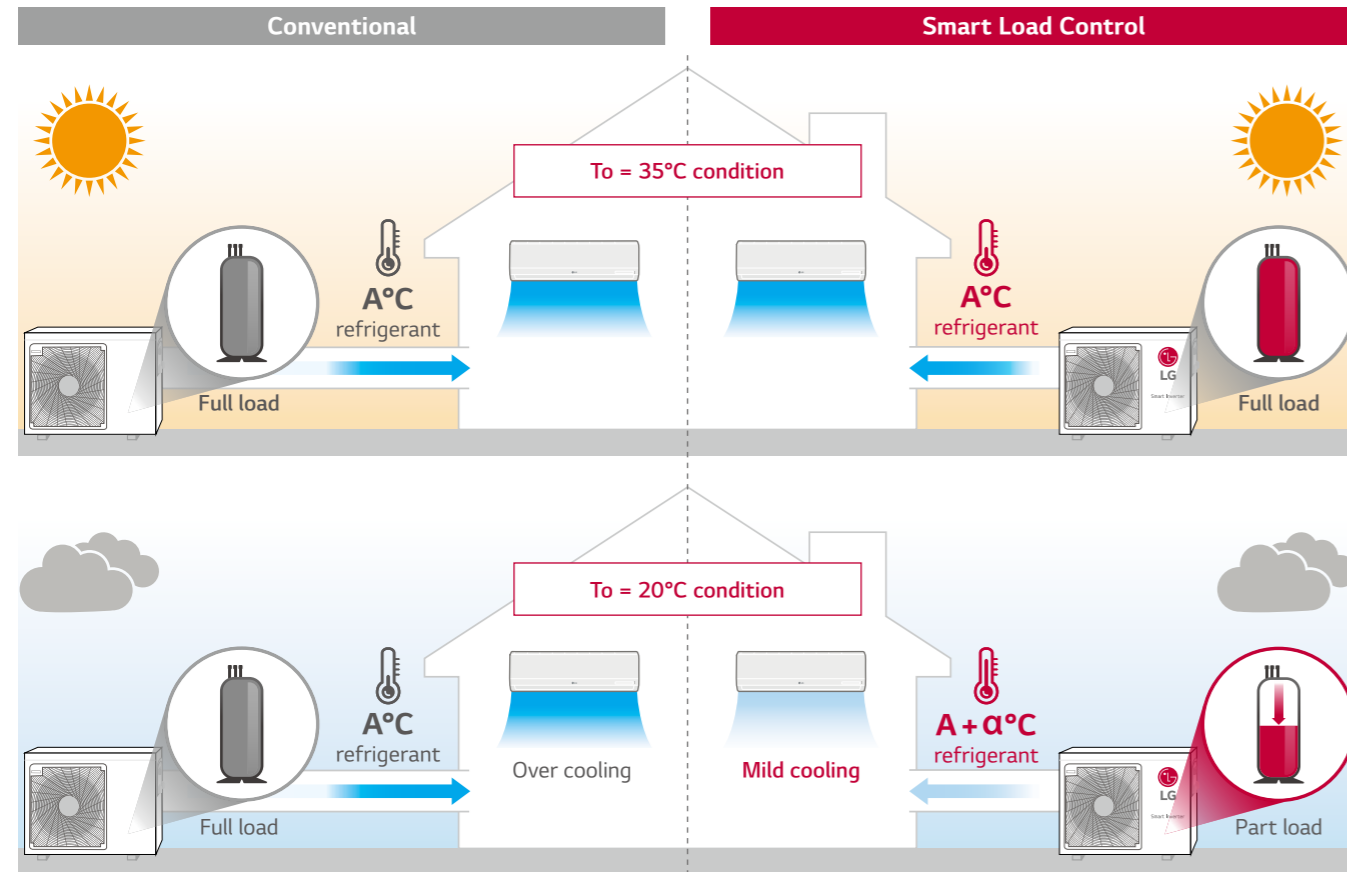

\* To : Outdoor temperature  
\* A is the indoor unit coil temperature

### • How to set dip switch

To operate smart load control, dip switch setting is needed. It can save energy on real time operation.

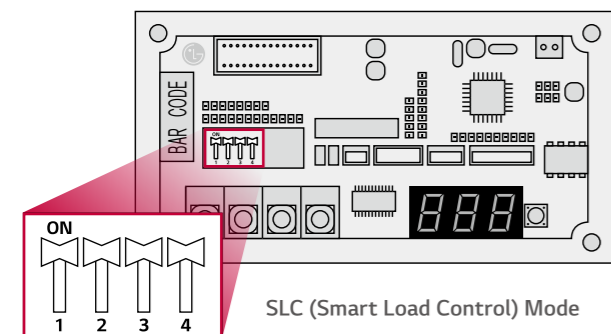

### • Real Time Energy Saving

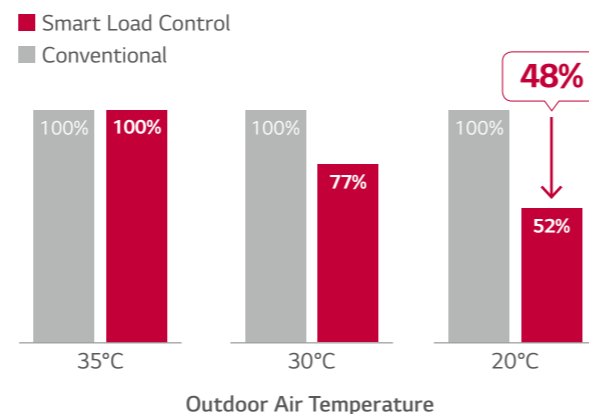

\* Applied models : MU2R15.U40 / MU2R17.U40 / MU3R19.UE0 / MU3R21.UE0 / MU4R25.U40 / MU4R27.U40 / MU5R30.U40 / MU5M40.U44

## Peak Current Control

The peak current control function keeps the air conditioner from running at the maximum level while maintaining current system setting, in order to reduce energy consumption. This function allows reducing energy costs during the peak periods of energy use when the energy fee is much higher.

### • How to set dip switch

**STEP 1** Max power consumption : 1.9 kW

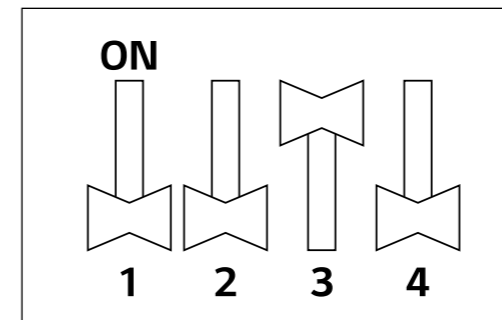

**STEP 2** Max power consumption : 1.7 kW

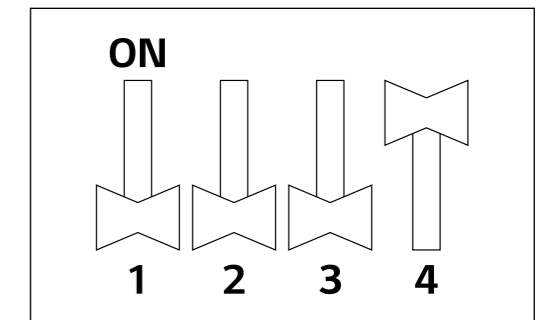

\* Full Load consumption : 2.5kW  
\* 7.0kW model  
\* LG Internal test result

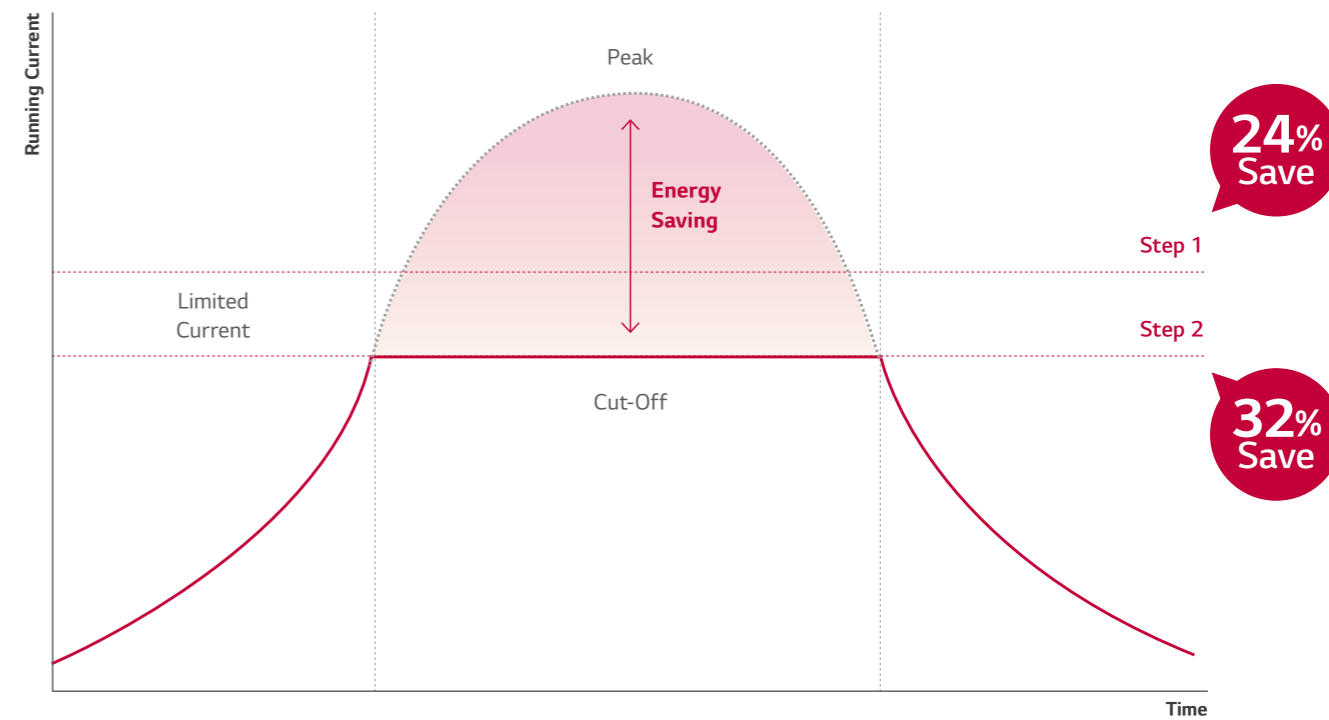

\* When using Peak current control, the cooling capacity may not be sufficient.  
\* 7.0kW model  
\* LG Internal test result

# EXTREME DURABILITY

## EXTREME DURABILITY

Product safety is emphasized by offering a 10-year warranty on the compressor to reassure customers about product durability.

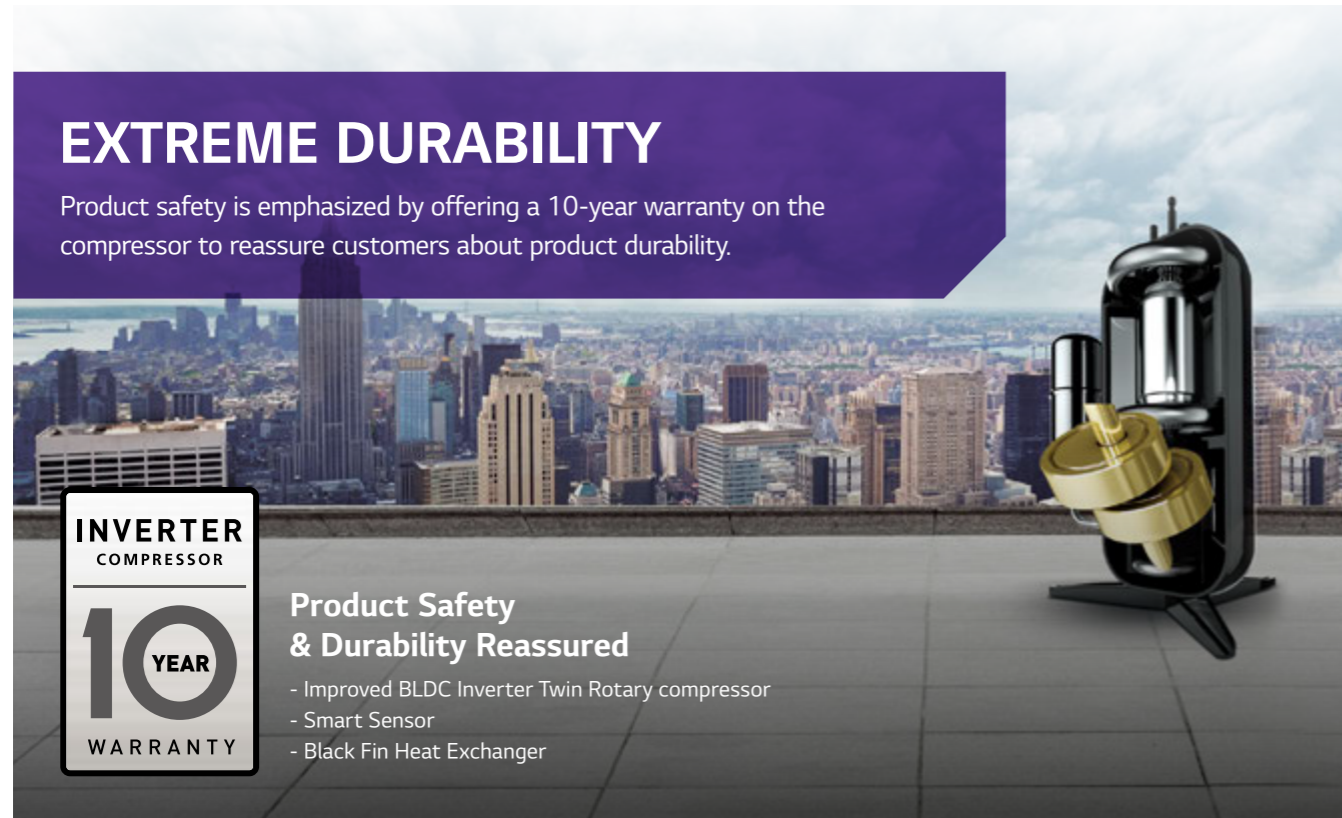

**INVERTER COMPRESSOR**

10

**YEAR WARRANTY**

**Product Safety & Durability Reassured**

- Improved BLDC Inverter Twin Rotary compressor
- Smart Sensor
- Black Fin Heat Exchanger

## Pressure Control Technology by Smart Sensor

Quicker and more reliable operation is possible from pressure control technology.

### • Field Failure Rate of Outdoor unit

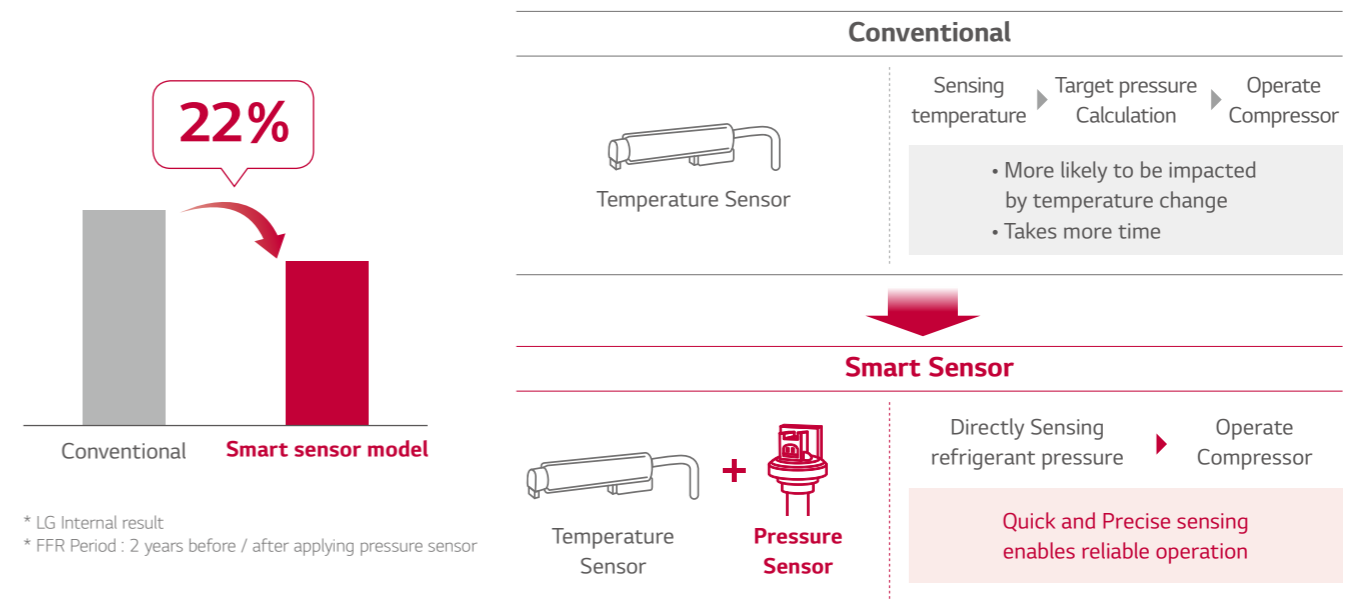

## Improved BLDC Inverter Twin Rotary Compressor

Parts of BLDC Inverter Twin Rotary Compressor have been improved to allow a longer life span.

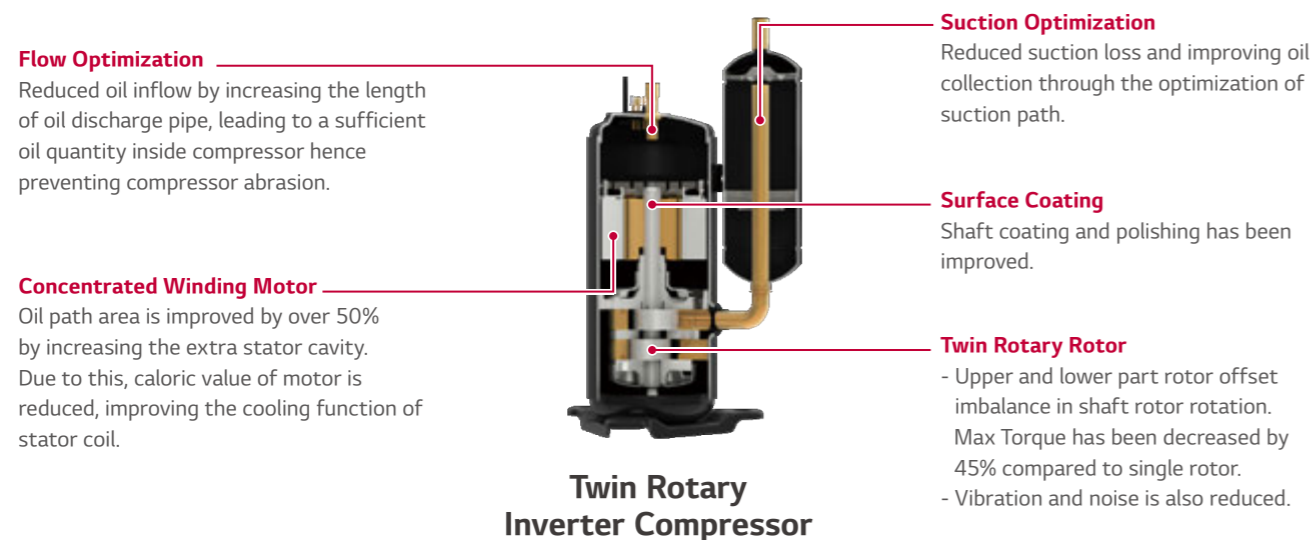

**Flow Optimization**  
Reduced oil inflow by increasing the length of oil discharge pipe, leading to a sufficient oil quantity inside compressor hence preventing compressor abrasion.

**Suction Optimization**  
Reduced suction loss and improving oil collection through the optimization of suction path.

**Concentrated Winding Motor**  
Oil path area is improved by over 50% by increasing the extra stator cavity. Due to this, caloric value of motor is reduced, improving the cooling function of stator coil.

**Surface Coating**  
Shaft coating and polishing has been improved.

**Twin Rotary Rotor**  
- Upper and lower part rotor offset imbalance in shaft rotor rotation. Max Torque has been decreased by 45% compared to single rotor.  
- Vibration and noise is also reduced.

**Twin Rotary Inverter Compressor**

## Black Fin Heat Exchanger

The black coating with enhanced epoxy resin is applied for strong protection from various corrosive external conditions such as salt contamination and air pollution including fumes from factories. Moreover, the hydrophilic film keeps water from accumulating on the heat exchanger's fin, minimizing moisture buildup and eventually making it even more corrosion resistant.

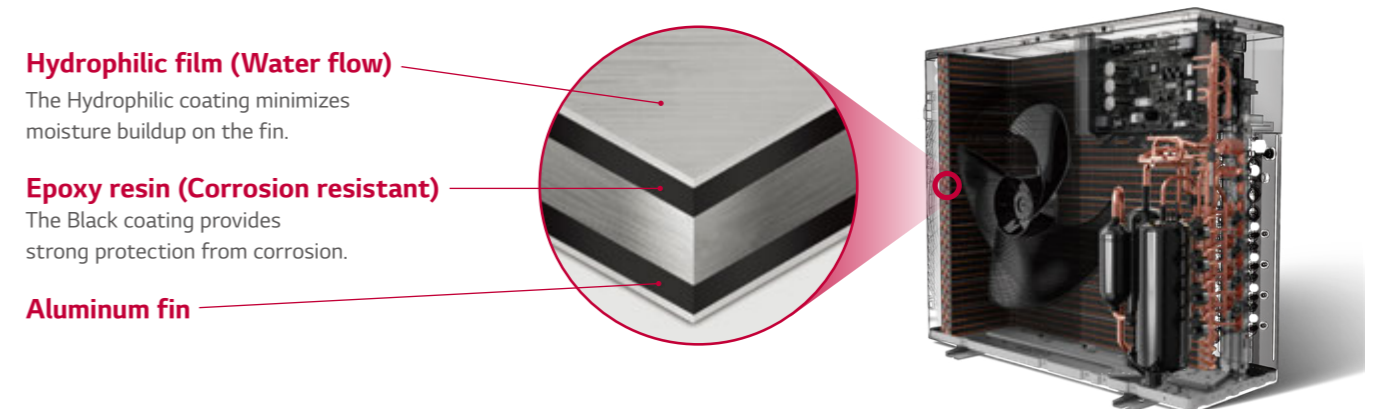

**Hydrophilic film (Water flow)**  
The Hydrophilic coating minimizes moisture buildup on the fin.

**Epoxy resin (Corrosion resistant)**  
The Black coating provides strong protection from corrosion.

**Aluminum fin**

# COMFORT AND CONVENIENCE

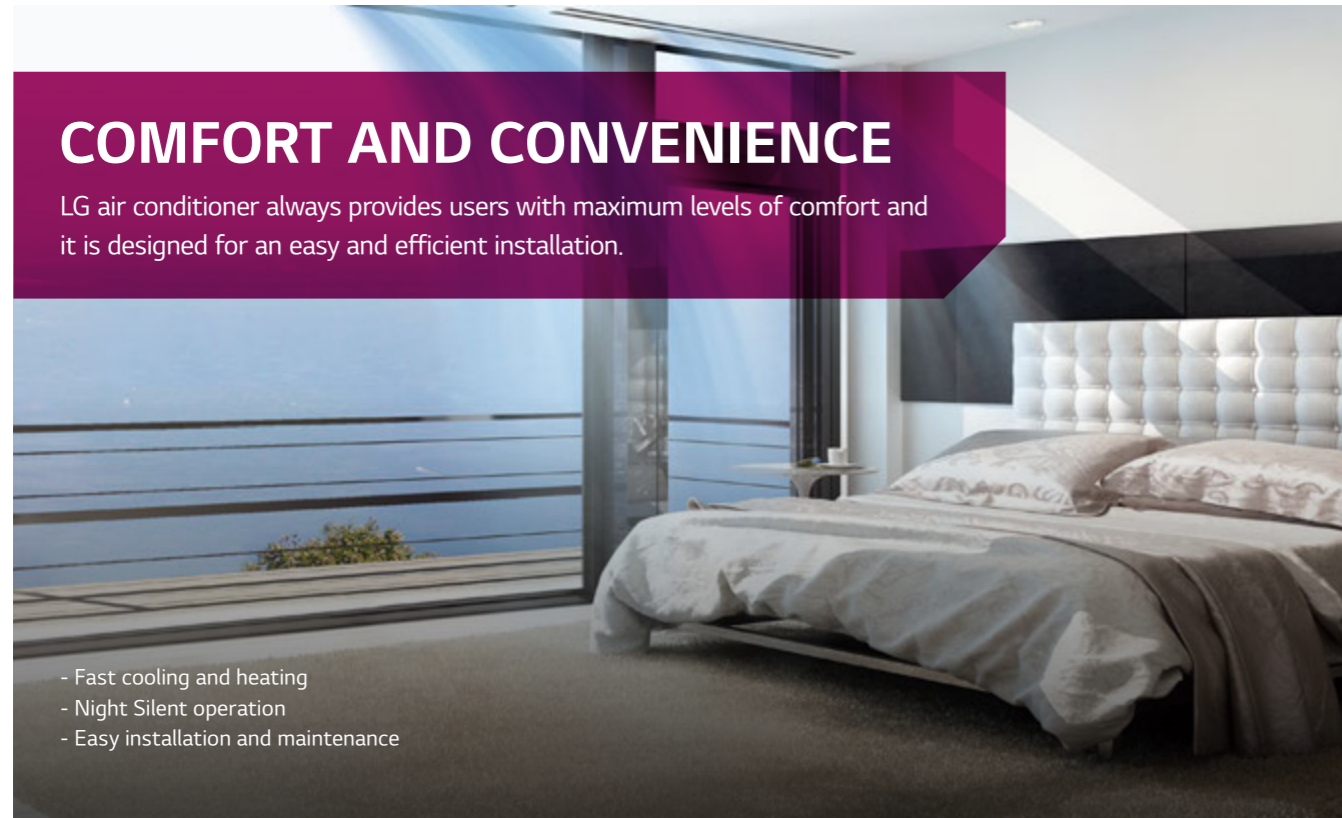

## Night Silent Operation

Night silent operation can reduce noise levels at night time by simply setting the dip switch on the PCB of the outdoor unit.

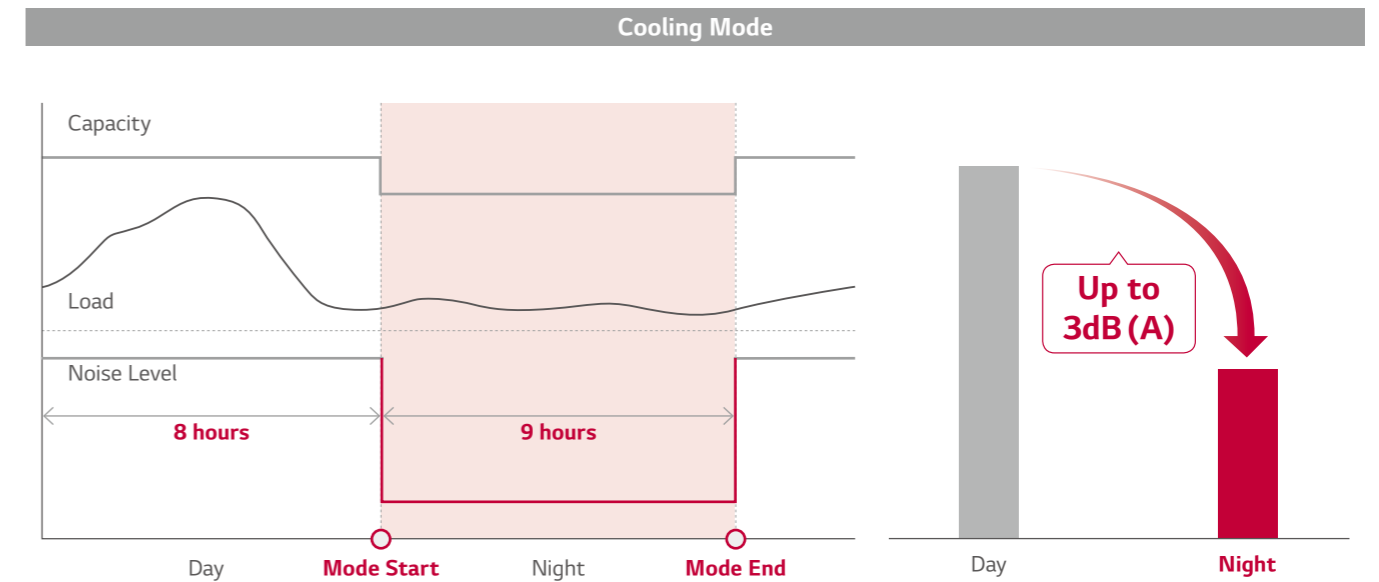

\* This function is only available for Cooling Mode.  
\* If you want to stop the Night Quiet Mode, Change the Dip Switch.

## Fast Cooling & Heating

Pressure control takes less time to reach the desired temperature up to 30% in cooling and 44% in heating with high level of accuracy and stability.

### • Cooling

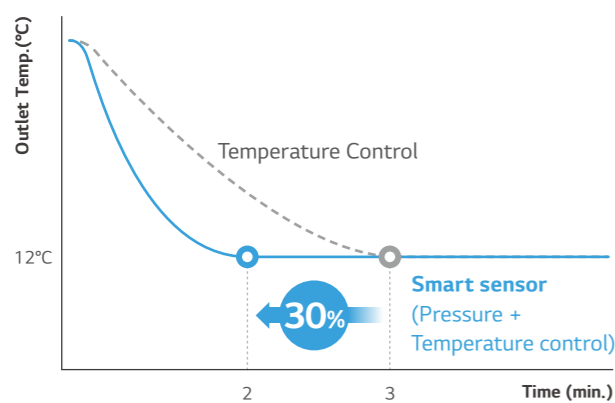

\* LG Internal test result

### • Heating

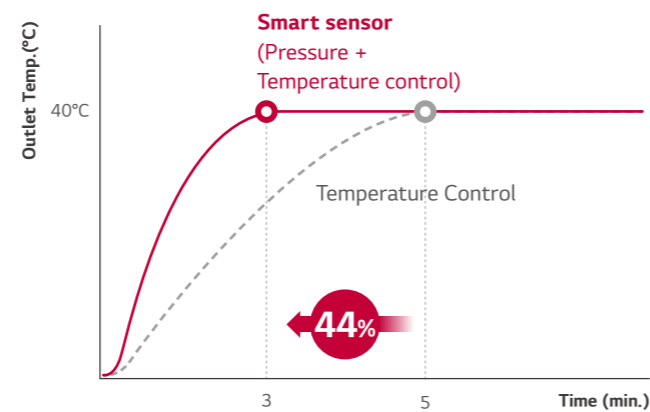

## Wiring Error Check

Installers can check whether the transmission cable has been connected correctly by using the wiring error check function. The wiring error check function can reduce the time taken to check for transmission cable errors.

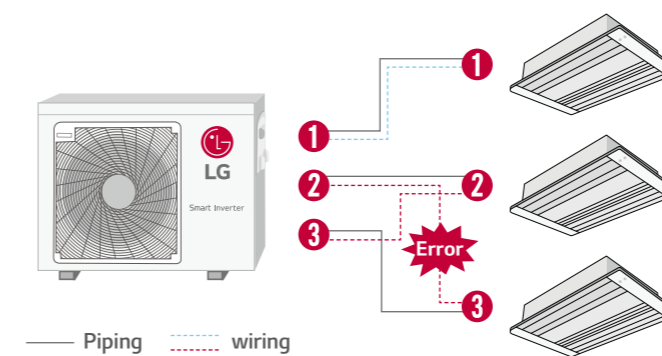

### • LED Result

- If the wiring is correct, the Green LED will light up.
- If the wiring is wrong, display as below
  - Red LED : Piping Number
  - Green LED : Wiring Number (Room)

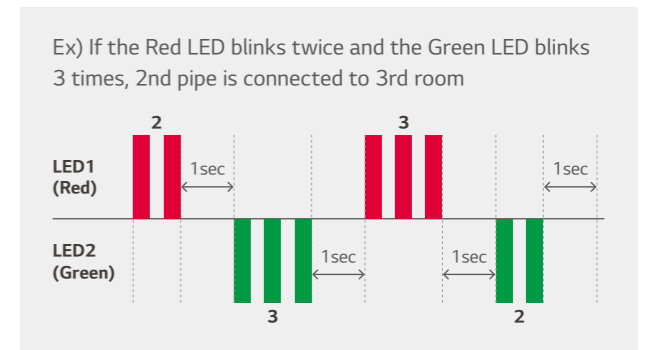

# COMFORT AND CONVENIENCE

## Monitoring PCB

If there is any problem, without disassembly of chassis, engineers can quickly check air conditioner's error code through 7-segment error indicator

**Conventional**

Many tools are needed for checking cycle data.

**Monitoring PCB**

Easy & Quick cycle data Check by Monitoring PCB

• UL4, UE4 chassis

**STEP 1**  
Opening the control cover

**3 SCREW**

**STEP 2**  
Simply Checking the data on PCB

7-segment error indicator

**STEP 3**  
Displayed Error code sample

0.5 sec off ↑ ↓ 0.5 sec off

### • Displayed Error code

ERROR CODE	CONTENTS	CASE OF ERROR	OUTDOOR STATUS
21	DC Link Peak (IPM Fault)	Over Rated Current	Off
22	CT 2 (Max CT)	Input Over Current	Off
23	DC Link Low Volt.	DC Link Volt is below 140V dc	Off
	DC Link High Volt.	DC Link Volt is above 420V dc	
25	Low Voltage / Over Voltage	Abnomal AC volt Input	Off
26	DC Compressor Position Error	Compressor Starting Fall Error	Off
27	PSC / PFC Fault Error	Over inverter PCB input Current	Off
29	COMP Over Current	Over inverter Compressor Current	Off

\* Applied models : MU2R15 UL0 / MU2R17 UL0 / MU3R19 UE0 / MU3R21 UE0

## LG MV (Monitoring View)

LG MV helps engineers to inspect and monitor air conditioning units easily.

Mobile MV

PC based LGMV  
(for service)

LGMV module  
(for service)

Operation information

Cycle View

## Forced Cooling Operation

The forced cooling operation allows refrigerant to be recharged or pumped down, regardless of the indoor temperature. More importantly this function can be used when indoor units are being moved or repaired.

Recharging

Pump Down

1 Close liquid valve  
2 Close gas valve

# R32 MULTI SPLIT

R32 MULTI SPLIT

## OUTDOOR UNITS



RESIDENTIAL

MU2R15  
MU2R17

(Unit : mm)



LG participates in the ECP programme for EUROVENT AC program.  
Check ongoing validity of certification  
: www.eurovent-certification.com

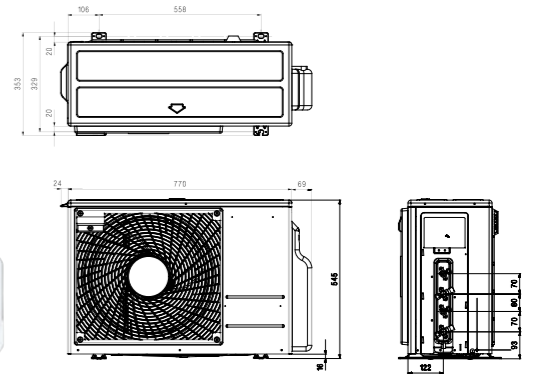

OUTDOOR UNIT				MU2R15.ULO	MU2R17.ULO
Compressor	Type			Twin Rotary	Twin Rotary
Capacity *	Cooling	Min / Nom / Max	kW	0.9 / 4.1 / 4.7	0.9 / 4.7 / 5.4
	Heating	Min / Nom / Max	kW	1.0 / 4.7 / 5.4	1.0 / 5.3 / 5.7
Low Temperature Capacity	Heating -7°C	Max	kW	3.3	3.7
Power Input *	Cooling	Min / Nom / Max	kW	0.2 / 1.0 / 1.4	0.2 / 1.3 / 1.7
	Heating	Min / Nom / Max	kW	0.2 / 1.1 / 1.4	0.2 / 1.3 / 1.6
Running Current	Cooling	Min / Nom / Max	A	1.1 / 4.6 / 6.4	1.1 / 5.6 / 7.9
	Heating	Min / Nom / Max	A	1.1 / 4.9 / 6.6	1.1 / 5.5 / 7.6
EER				4.14	3.75
COP				4.38	4.22
SEER				8.50	7.80
SCOP				4.20	4.20
Pdesign (@-10°C)			kW	4.10	4.10
Seasonal Energy Label	Cooling / Heating			A+++ (A+++ to D Scale) / A+	A++ (A++ to E Scale) / A+
Annual Energy Consumption	Cooling / Heating			169 / 1,367	210 / 1,367
Airflow Rate	Nom		m <sup>3</sup> /min	28.2	28.2
Sound Pressure	Cooling	Nom	dBA	48	48
	Heating	Nom	dBA	51	51
Sound Power	Cooling	Max	dBA	61	63
Dimensions	W x H x D		mm	770 x 545 x 288	770 x 545 x 288
Net Weight			Kg	36	36
Refrigerant	Type			R32	R32
	Charge		Kg	1.1	1.1
	Additional Charge		g/m	20	20
	GWP			675	675
	t-CO <sub>2</sub> , eq			0.74	0.74
Operation Range (Outdoor)	Cooling	Min / Max	°C DB	-10 / 48	-10 / 48
	Heating	Min / Max	°C WB	-18 / 18	-18 / 18
Power Supply			Ø / V / Hz	1 / 220-240 / 50	1 / 220-240 / 50
Power Supply Cable			No. x mm <sup>2</sup>	3C x 2.5	3C x 2.5
Transmission Cable			No. x mm <sup>2</sup>	4C x 0.75	4C x 0.75
Circuit Breaker			A	15	15
Piping Length Total			m	30	30
Piping Length per Branch		Max	m	20	20
Piping Elevation Difference	IDU - ODU	Max	m	15	15
	IDU - IDU	Max	m	7.5	7.5
Piping Connection	Liquid		mm (inch) x No.	Ø6.35 (1/4) x 2	Ø6.35 (1/4) x 2
	Gas		mm (inch) x No.	Ø9.52 (3/8) x 2	Ø9.52 (3/8) x 2

Notes :

- Capacities are based on the following conditions:  
Cooling : - Indoor Temperature 27°C (80.6°F) DB / 19°C (66.2°F) WB - Outdoor Temperature 35°C (95°F) DB / 24°C (75.2°F) WB  
Heating : - Indoor Temperature 20°C (68°F) DB / 15°C (59°F) WB - Outdoor Temperature 7°C (44.6°F) DB / 6°C (42.8°F) WB  
Piping Length - Interconnecting Piping Length 7.5m - Level Difference of Zero.
- \* : See page "Combination Table".
- Due to our policy of innovation some specifications may be changed without notification.
- At least two indoor units should be connected
- Minimum combination ratio should be more than 40%.
- This product contains fluorinated greenhouse gases (R32)



# OUTDOOR UNITS



**MU3R19  
MU3R21**



LG participates in the ECP programme for EUROVENT AC program.  
Check ongoing validity of certification  
: www.eurovent-certification.com

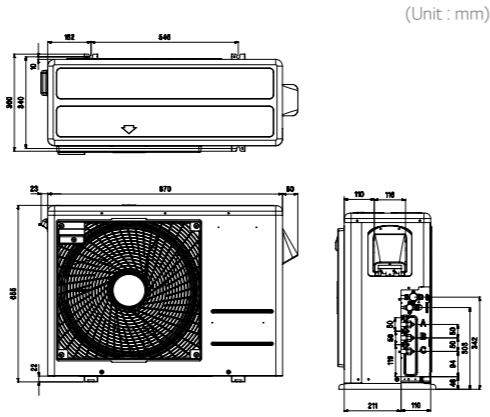

**MU4R25  
MU4R27  
MU5R30**



LG participates in the ECP programme for EUROVENT AC program.  
Check ongoing validity of certification  
: www.eurovent-certification.com

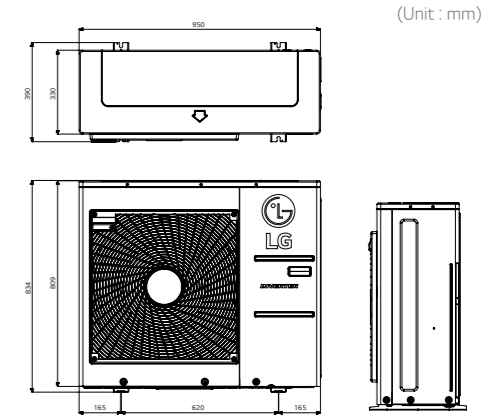

OUTDOOR UNIT				MU3R19.UE0	MU3R21.UE0
Compressor	Type			Twin Rotary	Twin Rotary
Capacity *	Cooling	Min / Nom / Max	kW	1.1 / 5.3 / 6.3	1.1 / 6.2 / 7.3
	Heating	Min / Nom / Max	kW	1.2 / 6.3 / 7.3	1.2 / 7.0 / 7.8
Low Temperature Capacity	Heating -7°C	Max	kW	4.4	4.9
Power Input *	Cooling	Min / Nom / Max	kW	0.2 / 1.2 / 1.8	0.2 / 1.4 / 2.1
	Heating	Min / Nom / Max	kW	0.3 / 1.4 / 2.0	0.3 / 1.6 / 2.3
Running Current	Cooling	Min / Nom / Max	A	1.1 / 5.3 / 8.1	1.1 / 6.7 / 9.6
	Heating	Min / Nom / Max	A	1.1 / 6.3 / 9.4	1.1 / 7.4 / 10.6
EER				4.59	4.27
COP				4.62	4.42
SEER				8.50	8.50
SCOP				4.21	4.21
Pdesign (@-10°C)			kW	4.90	4.90
Seasonal Energy Label	Cooling / Heating (A+++ to D Scale)			A+++ / A+	A+++ / A+
Annual Energy Consumption	Cooling / Heating			217 / 1,629	253 / 1,629
Airflow Rate	Nom	m <sup>3</sup> /min		50	50
Sound Pressure	Cooling	Nom	dBA	49	50
	Heating	Nom	dBA	54	54
Sound Power	Cooling	Max	dBA	63	64
Dimensions	W x H x D		mm	870 x 655 x 320	870 x 655 x 320
Net Weight			Kg	44	44
Refrigerant	Type			R32	R32
	Charge	Kg		1.4	1.4
	Additional Charge	g/m		20	20
	GWP			675	675
t-CO <sub>2</sub> eq			0.95	0.95	
Operation Range (Outdoor)	Cooling	Min / Max	°C DB	-10 / 48	-10 / 48
	Heating	Min / Max	°C WB	-18 / 18	-18 / 18
Power Supply			Ø / V / Hz	1 / 220-240 / 50	1 / 220-240 / 50
Power Supply Cable			No. x mm <sup>2</sup>	3C x 2.5	3C x 2.5
Transmission Cable			No. x mm <sup>2</sup>	4C x 0.75	4C x 0.75
Circuit Breaker			A	20	20
Piping Length Total			m	50	50
Piping Length per Branch	Max	m		25	25
Piping Elevation Difference	IDU - ODU	Max	m	15	15
	IDU - IDU	Max	m	7.5	7.5
Piping Connection	Liquid	mm (inch) x No.		Ø6.35 (1/4) x 3	Ø6.35 (1/4) x 3
	Gas	mm (inch) x No.		Ø9.52 (3/8) x 3	Ø9.52 (3/8) x 3

Notes :

- Capacities are based on the following conditions:  
Cooling : - Indoor Temperature 27°C (80.6°F) DB / 19°C (66.2°F) WB - Outdoor Temperature 35°C (95°F) DB / 24°C (75.2°F) WB  
Heating : - Indoor Temperature 20°C (68°F) DB / 15°C (59°F) WB - Outdoor Temperature 7°C (44.6°F) DB / 6°C (42.8°F) WB  
Piping Length - Interconnecting Piping Length 7.5m - Level Difference of Zero.
- \* : See page "Combination Table".
- Due to our policy of innovation some specifications may be changed without notification.
- At least two indoor units should be connected
- Minimum combination ratio should be more than 40%.
- This product contains fluorinated greenhouse gases (R32)

OUTDOOR UNIT				MU4R25.U40	MU4R27.U40	MU5R30.U40
Compressor	Type			Twin Rotary	Twin Rotary	Twin Rotary
Capacity *	Cooling	Min / Nom / Max	kW	1.3 / 7.0 / 8.5	1.3 / 7.9 / 9.5	1.3 / 8.8 / 10.6
	Heating	Min / Nom / Max	kW	1.5 / 8.4 / 9.4	1.5 / 9.1 / 10.6	1.5 / 10.1 / 12.1
Low Temperature Capacity	Heating -7°C	Max	kW	5.9	6.4	7.1
Power Input *	Cooling	Min / Nom / Max	kW	0.4 / 1.5 / 2.6	0.4 / 1.8 / 2.9	0.4 / 2.0 / 3.4
	Heating	Min / Nom / Max	kW	0.6 / 1.8 / 2.9	0.6 / 2.1 / 3.4	0.6 / 2.2 / 3.6
Running Current	Cooling	Min / Nom / Max	A	1.9 / 6.6 / 11.9	1.9 / 8.1 / 13.1	1.9 / 9.1 / 15.2
	Heating	Min / Nom / Max	A	2.8 / 8.3 / 13.1	2.8 / 9.4 / 15.3	2.8 / 9.7 / 16.3
EER				4.82	4.39	4.40
COP				4.61	4.39	4.70
SEER				8.20	8.00	8.20
SCOP				4.20	4.20	4.20
Pdesign (@-10°C)			kW	7.00	7.00	7.20
Seasonal Energy Label	Cooling / Heating (A++ to E Scale)			A++ / A+	A++ / A+	A++ / A+
Annual Energy Consumption	Cooling / Heating			299 / 2,333	346 / 2,333	376 / 2,467
Airflow Rate	Nom	m <sup>3</sup> /min		60	60	60
Sound Pressure	Cooling	Nom	dBA	49	50	50
	Heating	Nom	dBA	53	54	54
Sound Power	Cooling	Max	dBA	64	65	66
Dimensions	W x H x D		mm	950 x 834 x 330	950 x 834 x 330	950 x 834 x 330
Net Weight			Kg	61	61	61
Refrigerant	Type			R32	R32	R32
	Charge	Kg		2.3	2.3	2.6
	Additional Charge	g/m		20	20	20
	GWP			675	675	675
t-CO <sub>2</sub> eq			1.55	1.55	1.76	
Operation Range (Outdoor)	Cooling	Min / Max	°C DB	-10 / 48	-10 / 48	-10 / 48
	Heating	Min / Max	°C WB	-18 / 18	-18 / 18	-18 / 18
Power Supply			Ø / V / Hz	1 / 220-240 / 50	1 / 220-240 / 50	1 / 220-240 / 50
Power Supply Cable			No. x mm <sup>2</sup>	3C x 2.5	3C x 2.5	3C x 2.5
Transmission Cable			No. x mm <sup>2</sup>	4C x 0.75	4C x 0.75	4C x 0.75
Circuit Breaker			A	25	25	25
Piping Length Total			m	70	70	75
Piping Length per Branch	Max	m		25	25	25
Piping Elevation Difference	IDU - ODU	Max	m	15	15	15
	IDU - IDU	Max	m	7.5	7.5	7.5
Piping Connection	Liquid	mm(inch) x No.		Ø6.35 (1/4) x 4	Ø6.35 (1/4) x 4	Ø6.35 (1/4) x 5
	Gas	mm(inch) x No.		Ø9.52 (3/8) x 4	Ø9.52 (3/8) x 4	Ø9.52 (3/8) x 5

Notes :

- Capacities are based on the following conditions:  
Cooling : - Indoor Temperature 27°C (80.6°F) DB / 19°C (66.2°F) WB - Outdoor Temperature 35°C (95°F) DB / 24°C (75.2°F) WB  
Heating : - Indoor Temperature 20°C (68°F) DB / 15°C (59°F) WB - Outdoor Temperature 7°C (44.6°F) DB / 6°C (42.8°F) WB  
Piping Length - Interconnecting Piping Length 7.5m - Level Difference of Zero.
- \* : See page "Combination Table".
- Due to our policy of innovation some specifications may be changed without notification.
- At least two indoor units should be connected
- Minimum combination ratio should be more than 40%.
- This product contains fluorinated greenhouse gases (R32)

# WALL MOUNTED UNITS



		KBTU/H	5	7	9	12	15	18	24
		KW	1.5	2.1	2.6	3.5	4.2	5.3	7.0
Wall Mounted Unit	ARTCOOL Gallery		-	-	○● A09FR.NSF	○● A12AR.NSF	-	-	-
	ARTCOOL Mirror		-	●	○● AC09BQ.NSJ	○● AC12BQ.NSJ	-	○● AC18BQ.NSK	○● AM24BP.NSK



\* ARTCOOL Gallery is available in May, '19

## ARTCOOL Gallery

		A09FR.NSF		A12FR.NSF	
Capacity	Cooling / Heating	Nom	kW	2.6 / 2.9	3.5 / 3.9
Power Input		W x No.		40 x 1	40 x 1
Running Current		A		0.1	0.1
Power Supply		Ø / V / Hz		1 / 220-240 / 50	1 / 220-240 / 50
Air Flow Rate		H / M / L	m <sup>3</sup> /min	7.7 / 5.9 / 4.4	8.9 / 7.3 / 5.6
Sound Pressure	Cooling	H / M / L	dB(A)	38 / 32 / 27	44 / 38 / 32
Sound Power	Cooling		dB(A)	52	54
Dehumidification Rate			l/h	1.2	1.4
Dimensions	Body	W x H x D	mm	600 x 600 x 145	600 x 600 x 145
Net Weight	Body		kg	15.0	15.0
Piping	Liquid		mm (inch)	Ø 6.35 (1/4)	Ø 6.35 (1/4)
Connections	Gas		mm (inch)	Ø 9.52 (3/8)	Ø 9.52 (3/8)

## ARTCOOL Mirror

		AM07BP.NSJ	AC09BQ.NSJ	AC12BQ.NSJ	AC18BQ.NSJ	AM24BP.NSJ		
Capacity	Cooling / Heating	Nom	kW	2.1 / 2.3	2.5 / 3.2	3.5 / 3.8	5.0 / 5.8	6.6 / 7.5
Power Input		Nom	W	17	18	19	39	45
Running Current		Nom	A	0.14	0.16	0.17	0.28	0.33
Power Supply			Ø / V / Hz	1 / 220-240 / 50	1 / 220-240 / 50	1 / 220-240 / 50	1 / 220-240 / 50	1 / 220-240 / 50
Air Flow Rate		H / M / L	m <sup>3</sup> /min	8.6 / 7.2 / 5.6	9.2 / 7.4 / 5.6	9.6 / 8.1 / 5.6	14.2 / 11.3 / 9.9	15.2 / 12.7 / 10.2
Sound Pressure	Cooling	H / M / L	dB(A)	35 / 32 / 27	36 / 33 / 27	40 / 35 / 27	44 / 38 / 35	46 / 41 / 36
Sound Power	Cooling		dB(A)	57	57	57	59	65
Dehumidification Rate			l/h	0.9	1.1	1.2	1.9	2.6
Dimension		W x H x D	mm	837 x 308 x 192	837 x 308 x 192	837 x 308 x 192	998 x 345 x 212	998 x 345 x 212
Net weight			kg	9.1	9.9	9.9	13.2	11.6
Piping	Liquid		mm (inch)	Ø 6.35 (1/4)	Ø 6.35 (1/4)	Ø 6.35 (1/4)	Ø 6.35 (1/4)	Ø 6.35 (1/4)
Connection	Gas		mm (inch)	Ø 9.52 (3/8)	Ø 9.52 (3/8)	Ø 9.52 (3/8)	Ø 12.7 (1/2)	Ø 12.7 (1/2)

		KBTU/H	5	7	9	12	15	18	24
		KW	1.5	2.1	2.6	3.5	4.2	5.3	7.0
Wall Mounted Unit	ARTCOOL Silver	 <b>NEW</b>	-	-	○● AC09SQ.NSJ	○● AC12SQ.NSJ	-	○● AC18SQ.NSK	-
	Deluxe		-	●	○● DM07RP.NSJ	○● DC09RQ.NSJ	○● DC12RQ.NSJ	-	○● DC18RQ.NSK

**NEW** Silver Color is available from Mar, '19

## ARTCOOL Silver

		AC09SQ.NSJ		AC12SQ.NSJ		AC18SQ.NSK	
Capacity	Cooling / Heating	Nom	kW	2.5 / 3.2	3.5 / 3.8	5.0 / 5.8	
Power Input		Nom	W	18	19	39	
Running Current		Nom	A	0.16	0.17	0.28	
Power Supply			Ø / V / Hz	1 / 220-240 / 50	1 / 220-240 / 50	1 / 220-240 / 50	
Air Flow Rate		H / M / L	m <sup>3</sup> /min	9.2 / 7.4 / 5.6	9.6 / 8.1 / 5.6	14.2 / 11.3 / 9.9	
Sound Pressure	Cooling	H / M / L	dB(A)	36 / 33 / 27	40 / 35 / 27	44 / 38 / 35	
Sound Power	Cooling		dB(A)	57	57	59	
Dehumidification Rate			l/h	1.1	1.2	1.9	
Dimension		W x H x D	mm	837 x 308 x 192	837 x 308 x 192	998 x 345 x 212	
Net weight			kg	9.9	9.9	13.2	
Piping	Liquid		mm (inch)	Ø 6.35 (1/4)	Ø 6.35 (1/4)	Ø 6.35 (1/4)	
Connection	Gas		mm (inch)	Ø 9.52 (3/8)	Ø 9.52 (3/8)	Ø 12.7 (1/2)	

## DELUXE

		DM07RP.NSJ	DC09RQ.NSJ	DC12RQ.NSJ	DC18RQ.NSK	DM24RP.NSK		
Capacity	Cooling / Heating	Nom	kW	2.1 / 2.3	2.5 / 3.2	3.5 / 4.0	5.0 / 5.8	6.6 / 7.5
Power Input		Nom	W	17	18	19	39	45
Running Current		Nom	A	0.15	0.16	0.17	0.28	0.33
Power Supply			Ø / V / Hz	1 / 220-240 / 50	1 / 220-240 / 50	1 / 220-240 / 50	1 / 220-240 / 50	1 / 220-240 / 50
Air Flow Rate		H / M / L	m <sup>3</sup> /min	7.5 / 6.1 / 4.9	7.7 / 6.4 / 5.0	8.1 / 6.7 / 5.3	14.2 / 11.3 / 9.9	15.2 / 12.7 / 10.2
Sound Pressure	Cooling	H / M / L	dB(A)	35 / 31 / 26	36 / 32 / 27	38 / 34 / 29	44 / 38 / 34	47 / 41 / 36
Sound Power	Cooling		dB(A)	56	56	56	60	64
Dehumidification Rate			l/h	0.9	1.1	1.2	1.9	2.6
Dimension		W x H x D	mm	837 x 308 x 189	837 x 308 x 189	837 x 308 x 189	998 x 345 x 210	998 x 345 x 210
Net weight			kg	8.3	8.3	8.3	12.0	12.0
Piping	Liquid		mm (inch)	Ø 6.35 (1/4)	Ø 6.35 (1/4)	Ø 6.35 (1/4)	Ø 6.35 (1/4)	Ø 6.35 (1/4)
Connection	Gas		mm (inch)	Ø 9.52 (3/8)	Ø 9.52 (3/8)	Ø 9.52 (3/8)	Ø 12.7 (1/2)	Ø 12.7 (1/2)

\* This product contains Fluorinated greenhouse gases (R32).



※ For our policy of continuous product improvement, specification, design and features are subject to change without prior notice.

\* This product contains Fluorinated greenhouse gases (R32).

※ For our policy of continuous product improvement, specification, design and features are subject to change without prior notice.

R32 MULTI SPLIT

# WALL MOUNTED UNITS

		KBTU/H	5	7	9	12	15	18	24
		KW	1.5	2.1	2.6	3.5	4.2	5.3	7.0
Wall Mounted Unit	Standard Plus		PM05SP.NSJ	PM07SP.NSJ	PC09SQ.NSJ	PC12SQ.NSJ	PM15SP.NSJ	PC18SQ.NSK	PM24SP.NSK
			MJ05PC.NSJ	MJ07PC.NSJ	MJ09PC.NSJ	MJ12PC.NSJ	MJ15PC.NSJ	MJ18PC.NSK	MJ24PC.NSK

## STANDARD PLUS

			PM05SP.NSJ	PM07SP.NSJ	PC09SQ.NSJ	PC12SQ.NSJ	PM15SP.NSJ	PC18SQ.NSK	PM24SP.NSK
Capacity	Cooling / Heating	Nom kW	1.5 / 1.6	2.1 / 2.3	2.5 / 3.2	3.5 / 3.8	4.2 / 5.4	5.0 / 5.8	6.6 / 7.5
Power Input		Nom W	16	17	18	19	21	39	45
Running Current		Nom A	0.13	0.14	0.16	0.17	0.18	0.28	0.33
Power Supply		Ø / V / Hz	1 / 220-240 / 50	1 / 220-240 / 50	1 / 220-240 / 50	1 / 220-240 / 50	1 / 220-240 / 50	1 / 220-240 / 50	1 / 220-240 / 50
Air Flow Rate		H / M / L m <sup>3</sup> /min	8.3 / 6.7 / 5.6	8.6 / 7.2 / 5.6	9.2 / 7.4 / 5.6	9.6 / 8.1 / 5.6	10.0 / 8.5 / 6.1	14.2 / 11.3 / 9.9	15.2 / 12.7 / 10.2
Sound Pressure		H / M / L dB(A)	34 / 31 / 27	35 / 32 / 27	36 / 33 / 27	40 / 35 / 27	41 / 36 / 29	44 / 38 / 35	46 / 41 / 36
Sound Power		dB(A)	57	57	57	57	57	59	65
Dehumidification Rate		l/h	0.9	0.9	1.1	1.2	1.2	1.9	2.6
Dimension		W x H x D mm	837 x 308 x 189	837 x 308 x 189	837 x 308 x 189	837 x 308 x 189	837 x 308 x 189	998 x 345 x 210	998 x 345 x 210
Net weight		kg	7.4	7.4	8.7	8.7	8.7	12.0	12.8
Piping Connection	Liquid	mm (inch)	Ø 6.35 (1/4)	Ø 6.35 (1/4)	Ø 6.35 (1/4)	Ø 6.35 (1/4)	Ø 6.35 (1/4)	Ø 6.35 (1/4)	Ø 6.35 (1/4)
	Gas	mm (inch)	Ø 9.52 (3/8)	Ø 9.52 (3/8)	Ø 9.52 (3/8)	Ø 9.52 (3/8)	Ø 9.52 (3/8)	Ø 12.7 (1/2)	Ø 12.7 (1/2)

			MJ05PC.NSJ	MJ07PC.NSJ	MJ09PC.NSJ	MJ12PC.NSJ	MJ15PC.NSJ	MJ18PC.NSK	MJ24PC.NSK
Capacity	Cooling / Heating	Nom kW	1.5 / 1.6	2.1 / 2.3	2.5 / 3.2	3.5 / 3.8	4.2 / 5.4	5.0 / 5.8	6.6 / 7.5
Power Input		Nom W	16	17	18	19	21	39	45
Running Current		Nom A	0.13	0.14	0.16	0.17	0.18	0.28	0.33
Power Supply		Ø / V / Hz	1 / 220-240 / 50	1 / 220-240 / 50	1 / 220-240 / 50	1 / 220-240 / 50	1 / 220-240 / 50	1 / 220-240 / 50	1 / 220-240 / 50
Air Flow Rate		H / M / L m <sup>3</sup> /min	8.3 / 6.7 / 5.6	8.6 / 7.2 / 5.6	9.2 / 7.4 / 5.6	9.6 / 8.1 / 5.6	10.0 / 8.5 / 6.1	14.2 / 11.3 / 9.9	15.2 / 12.7 / 10.2
Sound Pressure		H / M / L dB(A)	34 / 31 / 27	35 / 32 / 27	36 / 33 / 27	40 / 35 / 27	41 / 36 / 29	44 / 38 / 35	46 / 41 / 36
Sound Power		dB(A)	57	57	57	57	57	59	65
Dehumidification Rate		l/h	0.9	0.9	1.1	1.2	1.2	1.9	2.6
Dimension		W x H x D mm	837 x 308 x 189	837 x 308 x 189	837 x 308 x 189	837 x 308 x 189	837 x 308 x 189	998 x 345 x 210	998 x 345 x 210
Net weight		kg	8.7	8.7	8.7	8.7	8.7	12.0	12.8
Piping Connection	Liquid	mm (inch)	Ø 6.35 (1/4)	Ø 6.35 (1/4)	Ø 6.35 (1/4)	Ø 6.35 (1/4)	Ø 6.35 (1/4)	Ø 6.35 (1/4)	Ø 6.35 (1/4)
	Gas	mm (inch)	Ø 9.52 (3/8)	Ø 9.52 (3/8)	Ø 9.52 (3/8)	Ø 9.52 (3/8)	Ø 9.52 (3/8)	Ø 12.7 (1/2)	Ø 12.7 (1/2)

\* This product contains Fluorinated greenhouse gases (R32).



※ For our policy of continuous product improvement, specification, design and features are subject to change without prior notice.

R32 MULTI SPLIT

# CEILING MOUNTED CASSETTE



RESIDENTIAL

		KBTU/H	5	7	9	12	15	18	24
		KW	1.5	2.1	2.6	3.5	4.2	5.3	7.0
Ceiling Mounted Cassette	1 Way Cassette		-	-	MT09R.NU1	MT11R.NU1	-	-	-
	4 Way Cassette		MT06R.NRO	MT08R.NRO	CT09R.NRO	CT12R.NRO	-	CT18R.NQO	CT24R.NPO

## 1Way Cassette

INDOOR				MT09R.NU1	MT11R.NU1
Capacity	Cooling / Heating	Nom kW		2.6 / 2.9	3.5 / 3.9
Power Input		Nom W		20	20
Running Current		Nom A		0.2	0.2
Power Supply		Ø / V / Hz		1 / 220-240 / 50	1 / 220-240 / 50
Air Flow Rate		H / M / L m <sup>3</sup> /min		7.5 / 7.3 / 6.8	8.1 / 7.4 / 7.0
Sound Pressure	Cooling	H / M / L dB(A)		36 / 34 / 32	37 / 36 / 33
Sound Power	Cooling	Max dB(A)		54	57
Dehumidification Rate		l/h		1.1	1.2
Dimensions	Body	W x H x D mm		860 x 132 x 450	860 x 132 x 450
Net Weight	Body	kg		13.5	13.5
Piping Connection	Liquid	mm (inch)		Ø6.35 (1/4)	Ø6.35 (1/4)
	Gas	mm (inch)		Ø9.52 (3/8)	Ø9.52 (3/8)
Decoration Panel	Model			PT-UUC1	PT-UUC1
	Color			Morning Fog (RAL120-4)	Morning Fog (RAL120-4)
	Dimensions	W x H x D mm		1,100 x 34 x 500	1,100 x 34 x 500
	Weight	kg		4.4	4.4

## 4Way Cassette



				MT06R.NRO	MT08R.NRO	CT09R.NRO	CT12R.NRO	CT18R.NQO	CT24R.NPO
Capacity	Cooling / Heating	Nom kW		1.5 / 1.6	2.1 / 2.3	2.6 / 2.9	3.5 / 3.9	5.3 / 5.8	6.7 / 7.5
Power Input		Nom W		20	20	20	20	40	60
Running Current		Nom A		0.40	0.40	0.40	0.40	0.40	0.60
Power Supply		Ø / V / Hz		1 / 220-240 / 50	1 / 220-240 / 50	1 / 220-240 / 50	1 / 220-240 / 50	1 / 220-240 / 50	1 / 220-240 / 50
Air Flow Rate		H / M / L m <sup>3</sup> /min		7.5 / 6.0 / 5.0	7.5 / 6.0 / 5.0	8.5 / 7.0 / 6.0	9.5 / 8.0 / 7.0	13.0 / 12.0 / 11.0	17.0 / 15.0 / 13.0
Sound Pressure		H / M / L dB(A)		31 / 27 / 24	31 / 27 / 24	36 / 33 / 30	38 / 35 / 32	41 / 39 / 36	38 / 36 / 34
Sound Power		dB(A)		48	48	52	52	57	57
Dehumidification Rate		l/h		-	-	0.9	1.4	2.0	2.7
Dimension		W x H x D mm		570 x 214 x 570	570 x 214 x 570	570 x 214 x 570	570 x 214 x 570	570 x 256 x 570	840 x 204 x 840
Net weight		kg		14.0	14.0	14.0	14.0	14.3	20.5
Piping Connection	Liquid	mm (inch)		Ø6.35 (1/4)	Ø6.35 (1/4)	Ø6.35 (1/4)	Ø6.35 (1/4)	Ø6.35 (1/4)	Ø6.35 (1/4)
	Gas	mm (inch)		Ø9.52 (3/8)	Ø9.52 (3/8)	Ø9.52 (3/8)	Ø9.52 (3/8)	Ø12.7 (1/2)	Ø12.7 (1/2)
Decoration Panel	Model			PT-QCHW0	PT-QCHW0	PT-QCHW0	PT-QCHW0	PT-QCHW0	PT-MCHW0
	Color			Morning Fog (RAL 120-4)					
	Dimensions	W x H x D mm		620 x 20 x 620	620 x 20 x 620	620 x 20 x 620	620 x 20 x 620	620 x 20 x 620	950 x 35 x 950
	Weight	kg		3.0	3.0	3.0	3.0	3.0	6.3

\* This product contains Fluorinated greenhouse gases (R32).

※ For our policy of continuous product improvement, specification, design and features are subject to change without prior notice.

# CEILING CONCEALED DUCT



		kBtu/h	05	07	09	12	15	18	24
		kW	1.5	2.1	2.6	3.5	4.2	5.3	7.0
Ceiling Concealed Duct	Mid / High Static Pressure		-	-	-	-	-	CM18R.N10	CM24R.N10
	Low Static Pressure		-	-	CL09R.N20	CL12R.N20	-	CL18R.N20	CL24R.N30

## Duct (Mid Static)

				CM18R.N10	CM24R.N10
Capacity	Cooling / Heating	Nom	kW	5.3 / 5.8	7.0 / 7.7
Power Input		Nom	W	160	180
Running Current		Nom	A	0.90	1.00
Power Supply			Ø / V / Hz	1 / 220-240 / 50	1 / 220-240 / 50
Air Flow Rate		H / M / L	m <sup>3</sup> /min	16.5 / 14.5 / 13.0	18.0 / 16.5 / 14.5
Sound Pressure		H / M / L	dB(A)	34 / 32 / 30	35 / 34 / 32
Sound Power			dB(A)	59	60
Dehumidification Rate			l/h	1.5	2.5
Dimension		W x H x D	mm	900 x 270 x 700	900 x 270 x 700
Net weight			kg	26.5	26.5
Piping Connection	Liquid		mm (inch)	Ø6.35 (1/4)	Ø6.35 (1/4)
	Gas		mm (inch)	Ø12.7 (1/2)	Ø12.7 (1/2)
External Static Pressure	Min-Max		mmAq (Pa)	2-15 (20-147)	2-15 (20-147)

## Duct (Low Static)

				CL09R.N20	CL12R.N20	CL18R.N20	CL24R.N30
Capacity	Cooling / Heating	Nom	kW	2.6 / 2.9	3.5 / 3.9	5.3 / 5.8	7.0 / 7.7
Power Input		Nom	W	100	100	140	160
Running Current		Nom	A	0.80	0.80	0.80	1.00
Power Supply			Ø / V / Hz	1 / 220-240 / 50	1 / 220-240 / 50	1 / 220-240 / 50	1 / 220-240 / 50
Air Flow Rate		H / M / L	m <sup>3</sup> /min	10.0 / 8.5 / 7.0	10.0 / 8.5 / 7.0	15.0 / 12.5 / 10.0	20.0 / 16.0 / 12.0
Sound Pressure		H / M / L	dB(A)	31 / 28 / 27	31 / 28 / 27	36 / 34 / 31	39 / 35 / 32
Sound Power			dB(A)	55	55	54	58
Dehumidification Rate			l/h	0.55	1.11	1.58	2.65
Dimension		W x H x D	mm	900 x 190 x 700	900 x 190 x 700	900 x 190 x 700	1,100 x 190 x 700
Net weight			kg	24.0	24.0	24.0	27.0
Piping Connection	Liquid		mm (inch)	Ø6.35 (1/4)	Ø6.35 (1/4)	Ø6.35 (1/4)	Ø6.35 (1/4)
	Gas		mm (inch)	Ø9.52 (3/8)	Ø9.52 (3/8)	Ø12.7 (1/2)	Ø12.7 (1/2)
External Static Pressure	Min-Max		mmAq (Pa)	0-5 (0-50)	0-5 (0-50)	0-5 (0-50)	0-5 (0-50)

※ For our policy of continuous product improvement, specification, design and features are subject to change without prior notice.

# COMBINATION TABLE

## MU2R15

Operation	Cooling											Input(W)			
	Combination of Indoor Unit (kBtu/h Class)					Total Capacity									
	UNIT-A	UNIT-B	UNIT-C	UNIT-D	Total	Min		Rated		Max		Min	Rated	Max	
1 UNIT	5					3,000	0.88	5,000	1.47	5,750	1.69	226	381	477	
	7					4,200	1.23	7,000	2.05	8,050	2.36	303	540	683	
	9					5,400	1.58	9,000	2.64	10,350	3.03	408	676	864	
	12					7,200	2.11	12,000	3.52	13,800	4.04	540	926	1,176	
2 UNIT	5				5	6,000	1.76	10,000	2.93	11,500	3.37	414	682	889	
	5			7		7,200	2.11	12,000	3.52	13,800	4.04	486	833	1,106	
	5		9			8,400	2.46	14,000	4.10	16,100	4.72	583	988	1,376	
	7		7			8,400	2.46	14,000	4.10	16,100	4.72	583	988	1,376	
	7		9			16	8,400	2.46	14,000	4.10	16,100	4.72	583	988	1,376
	5		12			17	8,400	2.46	14,000	4.10	16,100	4.72	583	988	1,376
	9		9			18	8,400	2.46	14,000	4.10	16,100	4.72	583	988	1,376
	7		12			19	8,400	2.46	14,000	4.10	16,100	4.72	583	988	1,376
9		12			21	8,400	2.46	14,000	4.10	16,100	4.72	583	988	1,376	

## MU2R17

Operation	Cooling											Input(W)			
	Combination of Indoor Unit (kBtu/h Class)					Total Capacity									
	UNIT-A	UNIT-B	UNIT-C	UNIT-D	Total	Min		Rated		Max		Min	Rated	Max	
1 UNIT	5					3,000	0.88	5,000	1.47	5,750	1.69	226	381	477	
	7					4,200	1.23	7,000	2.05	8,050	2.36	303	540	683	
	9					5,400	1.58	9,000	2.64	10,350	3.03	408	676	864	
	12					7,200	2.11	12,000	3.52	13,800	4.04	540	926	1,176	
	15					8,520	2.50	14,200	4.16	16,330	4.79	648	1,196	1,588	
2 UNIT	5				5	6,000	1.76	10,000	2.93	11,500	3.37	414	682	889	
	5			7		7,200	2.11	12,000	3.52	13,800	4.04	486	833	1,058	
	5		9			8,400	2.46	14,000	4.10	16,100	4.72	583	988	1,376	
	7		7			8,400	2.46	14,000	4.10	16,100	4.72	583	988	1,376	
	7		9			14	8,400	2.46	14,000	4.10	16,100	4.72	583	988	1,376
	7		9			16	9,600	2.81	16,000	4.69	18,400	5.39	657	1,251	1,699
	5		12			17	9,600	2.81	16,000	4.69	18,400	5.39	657	1,251	1,699
	9		9			18	9,600	2.81	16,000	4.69	18,400	5.39	657	1,251	1,699
	7		12			19	9,600	2.81	16,000	4.69	18,400	5.39	657	1,251	1,699
	5		15			20	9,600	2.81	16,000	4.69	18,400	5.39	657	1,251	1,699
	9		12			21	9,600	2.81	16,000	4.69	18,400	5.39	657	1,251	1,699
	7		15			22	9,600	2.81	16,000	4.69	18,400	5.39	657	1,251	1,699
9		15			24	9,600	2.81	16,000	4.69	18,400	5.39	657	1,251	1,699	
12		12			24	9,600	2.81	16,000	4.69	18,400	5.39	657	1,251	1,699	

Operation	Heating											Input(W)			
	Combination of Indoor Unit (kBtu/h Class)					Total Capacity									
	UNIT-A	UNIT-B	UNIT-C	UNIT-D	Total	Min		Rated		Max		Min	Rated	Max	
1 UNIT	5					3,300	0.97	5,500	1.61	6,050	1.77	235	380	472	
	7					5,040	1.48	8,400	2.46	9,240	2.71	355	604	721	
	9					6,480	1.90	10,800	3.17	11,880	3.48	454	784	949	
	12					7,920	2.32	13,200	3.87	14,520	4.26	554	969	1,185	
2 UNIT	5				5	6,600	1.93	11,000	3.22	12,100	3.55	408	706	854	
	5			7		7,920	2.32	13,200	3.87	14,520	4.26	498	872	1,066	
	5		9			14	9,600	2.81	16,000	4.69	18,400	5.39	613	1,066	1,433
	7		7			14	9,600	2.81	16,000	4.69	18,400	5.39	613	1,066	1,433
	7		9			16	9,600	2.81	16,000	4.69	18,400	5.39	613	1,066	1,433
	5		12			17	9,600	2.81	16,000	4.69	18,400	5.39	613	1,066	1,433
	9		9			18	9,600	2.81	16,000	4.69	18,400	5.39	613	1,066	1,433
	7		12			19	9,600	2.81	16,000	4.69	18,400	5.39	613	1,066	1,433
9		12			21	9,600	2.81	16,000	4.69	18,400	5.39	613	1,066	1,433	

Operation	Heating											Input(W)			
	Combination of Indoor Unit (kBtu/h Class)					Total Capacity									
	UNIT-A	UNIT-B	UNIT-C	UNIT-D	Total	Min		Rated		Max		Min	Rated	Max	
1 UNIT	5					3,300	0.97	5,500	1.61	6,050	1.77	235	380	472	
	7					5,040	1.48	8,400	2.46	9,240	2.71	355	604	721	
	9					6,480	1.90	10,800	3.17	11,880	3.48	454	758	920	
	12					7,920	2.32	13,200	3.87	14,520	4.26	554	942	1,155	
	15					9,900	2.90	16,500	4.84	18,150	5.32	706	1,187	1,489	
2 UNIT	5				5	6,600	1.93	11,000	3.22	12,100	3.55	408	706	854	
	5			7		7,920	2.32	13,200	3.87	14,520	4.26	498	872	1,066	
	5		9			14	9,600	2.81	16,000	4.69	18,400	5.39	613	1,066	1,433
	7		7			14	9,600	2.81	16,000	4.69	18,400	5.39	613	1,066	1,433
	7		9			16	10,800	3.17	18,000	5.28	19,400	5.69	706	1,247	1,633
	5		12			17	10,800	3.17	18,000	5.28	19,400	5.69	706	1,247	1,633
	9		9			18	10,800	3.17	18,000	5.28	19,400	5.69	706	1,247	1,633
	7		12			19	10,800	3.17	18,000	5.28	19,400	5.69	706	1,247	1,633
	5		15			20	10,800	3.17	18,000	5.28	19,400	5.69	706	1,247	1,633
	9		12			21	10,800	3.17	18,000	5.28	19,400	5.69	706	1,247	1,633
	7		15			22	10,800	3.17	18,000	5.28	19,400	5.69	706	1,247	1,633
	9		15			24	10,800	3.17	18,000	5.28	19,400	5.69	706	1,247	1,633
12		12			24	10,800	3.17	18,000	5.28	19,400	5.69	706	1,247	1,633	

※ For our policy of continuous product improvement, specification, design and features are subject to change without prior notice.

# COMBINATION TABLE

## MU3R19

Operation	Combination of Indoor Unit (kBtu/h Class)				Cooling									
					Total Capacity				Input(W)					
	UNIT-A	UNIT-B	UNIT-C	UNIT-D	Total	Min	kW	Rated	Max	Min	Rated	Max		
1 UNIT	5				5	3,600	1.06	5,000	1.47	6,000	1.76	235	356	527
	7				7	4,200	1.23	7,000	2.05	8,400	2.46	257	462	623
	9				9	5,400	1.58	9,000	2.64	10,800	3.17	346	580	814
	12				12	7,200	2.11	12,000	3.52	14,400	4.22	462	802	1,101
	15				15	8,520	2.50	14,200	4.16	17,040	4.99	556	983	1,276
	18				18	10,800	3.17	18,000	5.28	21,600	6.33	727	1,282	1,806
2 UNIT	5		5		10	6,000	1.76	10,000	2.93	12,000	3.52	373	620	854
	5		7		12	7,200	2.11	12,000	3.52	14,400	4.22	439	762	1,046
	5		9		14	8,400	2.46	14,000	4.10	16,800	4.92	528	909	1,246
	7		7		14	8,400	2.46	14,000	4.10	16,800	4.92	528	909	1,246
	7		9		16	9,600	2.81	16,000	4.69	19,200	5.63	597	1,061	1,504
	5		12		17	10,200	2.99	17,000	4.98	20,400	5.98	644	1,139	1,644
	9		9		18	10,800	3.17	18,000	5.28	21,600	6.33	691	1,218	1,761
	7		12		19	10,800	3.17	18,000	5.28	21,600	6.33	691	1,218	1,761
	5		15		20	10,800	3.17	18,000	5.28	21,600	6.33	691	1,218	1,761
	9		12		21	10,800	3.17	18,000	5.28	21,600	6.33	691	1,218	1,761
	7		15		22	10,800	3.17	18,000	5.28	21,600	6.33	691	1,218	1,761
	5		18		23	10,800	3.17	18,000	5.28	21,600	6.33	691	1,218	1,761
	9		15		24	10,800	3.17	18,000	5.28	21,600	6.33	691	1,218	1,761
	12		12		24	10,800	3.17	18,000	5.28	21,600	6.33	691	1,218	1,761
	7		18		25	10,800	3.17	18,000	5.28	21,600	6.33	691	1,218	1,761
	9		18		27	10,800	3.17	18,000	5.28	21,600	6.33	691	1,218	1,761
	12		15		27	10,800	3.17	18,000	5.28	21,600	6.33	691	1,218	1,761
	12		18		30	10,800	3.17	18,000	5.28	21,600	6.33	691	1,218	1,761
15		15		30	10,800	3.17	18,000	5.28	21,600	6.33	691	1,218	1,761	
3 UNIT	5		5		15	9,000	2.64	15,000	4.40	18,000	5.28	524	935	1,289
	5		7		17	10,200	2.99	17,000	4.98	20,400	5.98	611	1,082	1,562
	5		9		19	10,800	3.17	18,000	5.28	21,600	6.33	656	1,151	1,668
	5		7		19	10,800	3.17	18,000	5.28	21,600	6.33	656	1,151	1,668
	5		9		21	10,800	3.17	18,000	5.28	21,600	6.33	656	1,151	1,668
	7		7		21	10,800	3.17	18,000	5.28	21,600	6.33	656	1,151	1,668
	5		12		22	10,800	3.17	18,000	5.28	21,600	6.33	656	1,151	1,668
	5		9		23	10,800	3.17	18,000	5.28	21,600	6.33	656	1,151	1,668
	7		9		23	10,800	3.17	18,000	5.28	21,600	6.33	656	1,151	1,668
	5		12		24	10,800	3.17	18,000	5.28	21,600	6.33	656	1,151	1,668
	5		15		25	10,800	3.17	18,000	5.28	21,600	6.33	656	1,151	1,668
	7		9		25	10,800	3.17	18,000	5.28	21,600	6.33	656	1,151	1,668
	5		12		26	10,800	3.17	18,000	5.28	21,600	6.33	656	1,151	1,668
	7		12		26	10,800	3.17	18,000	5.28	21,600	6.33	656	1,151	1,668
	5		15		27	10,800	3.17	18,000	5.28	21,600	6.33	656	1,151	1,668
	9		9		27	10,800	3.17	18,000	5.28	21,600	6.33	656	1,151	1,668
	7		12		28	10,800	3.17	18,000	5.28	21,600	6.33	656	1,151	1,668
	5		15		29	10,800	3.17	18,000	5.28	21,600	6.33	656	1,151	1,668
	5		12		29	10,800	3.17	18,000	5.28	21,600	6.33	656	1,151	1,668
	7		15		29	10,800	3.17	18,000	5.28	21,600	6.33	656	1,151	1,668
	9		12		30	10,800	3.17	18,000	5.28	21,600	6.33	656	1,151	1,668

Operation	Combination of Indoor Unit (kBtu/h Class)				Heating									
					Total Capacity				Input(W)					
	UNIT-A	UNIT-B	UNIT-C	UNIT-D	Total	Min	kW	Rated	Max	Min	Rated	Max		
1 UNIT	5				5	4,000	1.17	5,500	1.61	6,325	1.85	248	368	539
	7				7	5,040	1.48	8,400	2.46	9,660	2.83	313	537	680
	9				9	6,480	1.90	10,800	3.17	12,420	3.64	401	702	896
	12				12	7,920	2.32	13,200	3.87	15,180	4.45	491	874	1,121
	15				15	9,900	2.90	16,500	4.84	18,975	5.56	631	1,105	1,479
	18				18	11,880	3.48	19,800	5.80	22,770	6.67	775	1,376	1,829
2 UNIT	5		5		10	7,200	2.11	12,000	3.52	13,800	4.04	424	736	957
	5		7		12	8,640	2.53	14,400	4.22	16,560	4.85	511	903	1,204
	5		9		14	10,080	2.95	16,800	4.92	19,320	5.66	622	1,075	1,435
	7		7		14	10,080	2.95	16,800	4.92	19,320	5.66	622	1,075	1,435
	7		9		16	11,520	3.38	19,200	5.63	22,080	6.47	713	1,255	1,676
	5		12		17	12,240	3.59	20,400	5.98	23,460	6.88	760	1,361	1,801
	9		9		18	12,960	3.80	21,600	6.33	24,840	7.28	807	1,442	2,028
	7		12		19	12,960	3.80	21,600	6.33	24,840	7.28	807	1,442	2,028
	5		15		20	12,960	3.80	21,600	6.33	24,840	7.28	807	1,442	2,028
	9		12		21	12,960	3.80	21,600	6.33	24,840	7.28	807	1,442	2,028
	7		15		22	12,960	3.80	21,600	6.33	24,840	7.28	807	1,442	2,028
	5		18		23	12,960	3.80	21,600	6.33	24,840	7.28	807	1,442	2,028
	9		15		24	12,960	3.80	21,600	6.33	24,840	7.28	807	1,442	2,028
	12		12		24	12,960	3.80	21,600	6.33	24,840	7.28	807	1,442	2,028
	7		18		25	12,960	3.80	21,600	6.33	24,840	7.28	807	1,442	2,028
	9		18		27	12,960	3.80	21,600	6.33	24,840	7.28	807	1,442	2,028
	12		15		27	12,960	3.80	21,600	6.33	24,840	7.28	807	1,442	2,028
	12		18		30	12,960	3.80	21,600	6.33	24,840	7.28	807	1,442	2,028
15		15		30	12,960	3.80	21,600	6.33	24,840	7.28	807	1,442	2,028	
3 UNIT	5		5		15	10,800	3.17	18,000	5.28	20,700	6.07	634	1,118	1,476
	5		7		17	12,240	3.59	20,400	5.98	23,460	6.88	722	1,293	1,711
	5		9		19	12,960	3.80	21,600	6.33	24,840	7.28	766	1,370	1,944
	5		7		19	12,960	3.80	21,600	6.33	24,840	7.28	766	1,370	1,944
	5		9		21	12,960	3.80	21,600	6.33	24,840	7.28	766	1,370	1,944
	7		7		21	12,960	3.80	21,600	6.33	24,840	7.28	766	1,370	1,944
	5		12		22	12,960	3.80	21,600	6.33	24,840	7.28	766	1,370	1,944
	5		9		23	12,960	3.80	21,600	6.33	24,840	7.28	766	1,370	1,944
	7		9		23	12,960	3.80	21,600	6.33	24,840	7.28	766	1,370	1,944
	5		12		24	12,960	3.80	21,600	6.33	24,840	7.28	766	1,370	1,944
	5		15		25	12,960	3.80	21,600	6.33	24,840	7.28	766	1,370	1,944
	7		9		25	12,960	3.80	21,600	6.33	24,840	7.28	766	1,370	1,944
	5		12		26	12,960	3.80	21,600	6.33	24,840	7.28	766	1,370	1,944
	7		12		26	12,960	3.80	21,600	6.33	24,840	7.28	766	1,370	1,944
	5		15		27	12,960	3.80	21,600	6.33	24,840	7.28	766	1,370	1,944
	9		9		27	12,960	3.80	21,600	6.33	24,840	7.28	766	1,370	1,944
	7		12		28	12,960	3.80	21,600	6.33	24,840	7.28	766	1,370	1,944
	5		15		29	12,960	3.80	21,600	6.33	24,840	7.28	766	1,370	1,944
	5		12		29	12,960	3.80	21,600	6.33	24,840	7.28	7		

# COMBINATION TABLE

## MU3R21

Operation	Combination of Indoor Unit (kBtu/h Class)				Cooling							Input(W)		
					Total Capacity									
	UNIT-A	UNIT-B	UNIT-C	UNIT-D	Total	Min		Rated		Max				
1 UNIT	5				5	3,600	1.06	5,000	1.47	6,000	1.76	235	356	527
	7				7	4,200	1.23	7,000	2.05	8,400	2.46	257	462	623
	9				9	5,400	1.58	9,000	2.64	10,800	3.17	346	580	814
	12				12	7,200	2.11	12,000	3.52	14,400	4.22	462	802	1,101
	15				15	8,520	2.50	14,200	4.16	17,040	4.99	556	983	1,276
	18				18	10,800	3.17	18,000	5.28	21,600	6.33	727	1,282	1,806
2 UNIT	5	5			10	6,000	1.76	10,000	2.93	12,000	3.52	373	620	854
	5	7			12	7,200	2.11	12,000	3.52	14,400	4.22	439	762	1,046
	5	9			14	8,400	2.46	14,000	4.10	16,800	4.92	528	909	1,246
	7	7			14	8,400	2.46	14,000	4.10	16,800	4.92	528	909	1,246
	7	9			16	9,600	2.81	16,000	4.69	19,200	5.63	597	1,061	1,504
	5	12			17	10,200	2.99	17,000	4.98	20,400	5.98	644	1,139	1,644
	9	9			18	10,800	3.17	18,000	5.28	21,600	6.33	691	1,218	1,761
	7	12			19	11,400	3.34	19,000	5.57	22,800	6.68	714	1,343	1,950
	5	15			20	12,000	3.52	20,000	5.86	23,100	6.77	762	1,436	1,999
	9	12			21	12,600	3.69	21,000	6.15	23,100	6.77	811	1,532	1,999
	7	15			22	12,600	3.69	21,000	6.15	23,100	6.77	811	1,532	1,999
	5	18			23	12,600	3.69	21,000	6.15	23,100	6.77	811	1,532	1,999
	9	15			24	12,600	3.69	21,000	6.15	23,100	6.77	811	1,532	1,999
	12	12			24	12,600	3.69	21,000	6.15	23,100	6.77	811	1,532	1,999
	7	18			25	12,600	3.69	21,000	6.15	23,100	6.77	811	1,532	1,999
	9	18			27	12,600	3.69	21,000	6.15	23,100	6.77	811	1,532	1,999
	12	15			27	12,600	3.69	21,000	6.15	23,100	6.77	811	1,532	1,999
	12	18			30	12,600	3.69	21,000	6.15	23,100	6.77	811	1,532	1,999
15	15			30	12,600	3.69	21,000	6.15	23,100	6.77	811	1,532	1,999	
15	18			33	12,600	3.69	21,000	6.15	23,100	6.77	811	1,532	1,999	
3 UNIT	5	5	5		15	9,000	2.64	15,000	4.40	18,000	5.28	524	935	1,289
	5	5	7		17	10,200	2.99	17,000	4.98	20,400	5.98	611	1,082	1,562
	5	5	9		19	11,400	3.34	19,000	5.57	22,800	6.68	679	1,276	1,824
	5	7	7		19	11,400	3.34	19,000	5.57	22,800	6.68	679	1,276	1,824
	5	7	9		21	12,600	3.69	21,000	6.15	25,000	7.33	770	1,444	2,073
	7	7	7		21	12,600	3.69	21,000	6.15	25,000	7.33	770	1,444	2,073
	5	5	12		22	12,600	3.69	21,000	6.15	25,000	7.33	770	1,444	2,073
	5	9	9		23	12,600	3.69	21,000	6.15	25,000	7.33	770	1,444	2,073
	7	7	9		23	12,600	3.69	21,000	6.15	25,000	7.33	770	1,444	2,073
	5	7	12		24	12,600	3.69	21,000	6.15	25,000	7.33	770	1,444	2,073
	5	5	15		25	12,600	3.69	21,000	6.15	25,000	7.33	770	1,444	2,073
	7	9	9		25	12,600	3.69	21,000	6.15	25,000	7.33	770	1,444	2,073
	5	9	12		26	12,600	3.69	21,000	6.15	25,000	7.33	770	1,444	2,073
	7	7	12		26	12,600	3.69	21,000	6.15	25,000	7.33	770	1,444	2,073
	5	7	15		27	12,600	3.69	21,000	6.15	25,000	7.33	770	1,444	2,073
	9	9	9		27	12,600	3.69	21,000	6.15	25,000	7.33	770	1,444	2,073
	5	5	18		28	12,600	3.69	21,000	6.15	25,000	7.33	770	1,444	2,073
	7	9	12		28	12,600	3.69	21,000	6.15	25,000	7.33	770	1,444	2,073
	5	9	15		29	12,600	3.69	21,000	6.15	25,000	7.33	770	1,444	2,073
	5	12	12		29	12,600	3.69	21,000	6.15	25,000	7.33	770	1,444	2,073
	7	7	15		29	12,600	3.69	21,000	6.15	25,000	7.33	770	1,444	2,073
	5	7	18		30	12,600	3.69	21,000	6.15	25,000	7.33	770	1,444	2,073
	9	9	12		30	12,600	3.69	21,000	6.15	25,000	7.33	770	1,444	2,073
	7	9	15		31	12,600	3.69	21,000	6.15	25,000	7.33	770	1,444	2,073
7	12	12		31	12,600	3.69	21,000	6.15	25,000	7.33	770	1,444	2,073	
5	12	15		32	12,600	3.69	21,000	6.15	25,000	7.33	770	1,444	2,073	
5	9	18		32	12,600	3.69	21,000	6.15	25,000	7.33	770	1,444	2,073	
7	7	18		32	12,600	3.69	21,000	6.15	25,000	7.33	770	1,444	2,073	
9	9	15		33	12,600	3.69	21,000	6.15	25,000	7.33	770	1,444	2,073	
9	12	12		33	12,600	3.69	21,000	6.15	25,000	7.33	770	1,444	2,073	

Operation	Combination of Indoor Unit (kBtu/h Class)				Heating							Input(W)		
					Total Capacity									
	UNIT-A	UNIT-B	UNIT-C	UNIT-D	Total	Min		Rated		Max				
1 UNIT	5				5	4,000	1.17	5,500	1.61	6,325	1.85	248	368	539
	7				7	5,040	1.48	8,400	2.46	9,660	2.83	313	537	680
	9				9	6,480	1.90	10,800	3.17	12,420	3.64	401	702	896
	12				12	7,920	2.32	13,200	3.87	15,180	4.45	491	874	1,121
	15				15	9,900	2.90	16,500	4.84	18,975	5.56	631	1,105	1,479
	18				18	11,880	3.48	19,800	5.80	22,770	6.67	775	1,376	1,829
2 UNIT	5	5			10	7,200	2.11	12,000	3.52	13,800	4.04	424	736	957
	5	7			12	8,640	2.53	14,400	4.22	16,560	4.85	511	903	1,204
	5	9			14	10,080	2.95	16,800	4.92	19,320	5.66	622	1,075	1,435
	7	7			14	10,080	2.95	16,800	4.92	19,320	5.66	622	1,075	1,435
	7	9			16	11,520	3.38	19,200	5.63	22,080	6.47	713	1,255	1,676
	5	12			17	12,240	3.59	20,400	5.98	23,460	6.88	760	1,308	1,801
	9	9			18	12,960	3.80	21,600	6.33	24,840	7.28	807	1,388	2,028
	7	12			19	13,320	3.90	22,200	6.51	25,530	7.48	831	1,442	2,135
	5	15			20	13,740	4.03	22,900	6.71	26,335	7.72	854	1,496	2,245
	9	12			21	14,400	4.22	24,000	7.03	26,500	7.77	903	1,580	2,302
	7	15			22	14,400	4.22	24,000	7.03	26,500	7.77	903	1,580	2,302
	5	18			23	14,400	4.22	24,000	7.03	26,500	7.77	903	1,580	2,302
	9	15			24	14,400	4.22	24,000	7.03	26,500	7.77	903	1,580	2,302
	12	12			24	14,400	4.22	24,000	7.03	26,500	7.77	903	1,580	2,302
	7	18			25	14,400	4.22	24,000	7.03	26,500	7.77	903	1,580	2,302
	9	18			27	14,400	4.22	24,000	7.03	26,500	7.77	903	1,580	2,302
	12	15			27	14,400	4.22	24,000	7.03	26,500	7.77	903	1,580	2,302
	12	18			30	14,400	4.22	24,000	7.03	26,500	7.77	903	1,580	2,302
15	15			30	14,400	4.22	24,000	7.03	26,500	7.77	903	1,580	2,302	
15	18			33	14,400	4.22	24,000	7.03	26,500	7.77	903	1,580	2,302	
3 UNIT	5	5	5		15	10,800	3.17	18,000	5.28	20,700	6.07	634	1,118	1,476
	5	5	7		17	12,240	3.59	20,400	5.98	23,460	6.88	722	1,293	1,711
	5	5	9		19	13,320	3.90	22,200	6.51	25,530	7.48	789	1,422	2,059
	5	7	7		19	13,320	3.90	22,200	6.51	25,530	7.48	789	1,422	2,059
	5	7	9		21	14,400	4.22	24,000	7.03	26,500	7.77	857	1,591	2,241
	7	7	7		21	14,400	4.22	24,000	7.03	26,500	7.77	857	1,591	2,241
	5	5	12		22	14,400	4.22	24,000	7.03	26,500	7.77	857	1,591	2,241
	5	9	9		23	14,400	4.22	24,000	7.03	26,500	7.77	857	1,591	2,241
	7	7	9		23	14,400	4.22	24,000	7.03	26,500	7.77	857	1,591	2,241
	5	7	12		24	14,400	4.22	24,000	7.03	26,500	7.77	857	1,591	2,241
	5	5	15		25	14,400	4.22	24,000	7.03	26,500	7.77	857	1,591	2,241
	7	9	9		25	14,400	4.22	24,000	7.03	26,500	7.77	857	1,591	2,241
	5	9	12		26	14,400	4.22	24,000	7.03	26,500	7.77	857	1,591	2,241
	7	7	12		26	14,400	4.22	24,000	7.03	26,500	7.77	857	1,591	2,241
	5	7	15		27	14,400	4.22	24,000	7.03	26,500	7.77	857	1,591	2,241
	9	9	9		27									

# COMBINATION TABLE

## MU4R25

Operation	Cooling														
	Combination of Indoor Unit (kBtu/h Class)					Total Capacity						Input(W)			
						Min		Rated		Max		Min	Rated	Max	
UNIT-A	UNIT-B	UNIT-C	UNIT-D	Total	Btu/h	kW	Btu/h	kW	Btu/h	kW	Min	Rated	Max		
1 UNIT	5				5	4,500	1.32	5,000	1.47	6,000	1.76	416	418	629	
	7				7	4,800	1.41	7,000	2.05	8,400	2.46	416	494	681	
	9				9	5,400	1.58	9,000	2.64	10,800	3.17	416	617	884	
	12				12	7,200	2.11	12,000	3.52	14,400	4.22	494	846	1,184	
	15				15	8,520	2.50	14,200	4.16	17,040	4.99	592	1,029	1,432	
	18				18	10,800	3.17	18,000	5.28	21,600	6.33	769	1,328	1,852	
	24				24	14,400	4.22	24,000	7.03	25,500	7.47	1,029	1,815	2,604	
	5	5			10	6,000	1.76	10,000	2.93	12,000	3.52	378	623	876	
	5	7			12	7,200	2.11	12,000	3.52	14,400	4.22	444	761	1,066	
	5	9			14	8,400	2.46	14,000	4.10	16,800	4.92	533	927	1,261	
	7	7			14	8,400	2.46	14,000	4.10	16,800	4.92	533	927	1,261	
	7	9			16	9,600	2.81	16,000	4.69	19,200	5.63	601	1,072	1,461	
2 UNIT	5	12			17	10,200	2.99	17,000	4.98	20,400	5.98	646	1,145	1,578	
	9	9			18	10,800	3.17	18,000	5.28	21,600	6.33	692	1,220	1,667	
	7	12			19	11,400	3.34	19,000	5.57	22,800	6.68	715	1,296	1,787	
	5	15			20	12,000	3.52	20,000	5.86	24,000	7.03	761	1,372	1,878	
	9	12			21	12,600	3.69	21,000	6.15	24,150	7.08	808	1,449	1,927	
	7	15			22	13,200	3.87	22,000	6.45	25,300	7.42	855	1,501	2,066	
	5	18			23	13,800	4.04	23,000	6.74	26,450	7.75	879	1,580	2,261	
	9	15			24	14,400	4.22	24,000	7.03	28,800	8.44	927	1,675	2,572	
	12	12			24	14,400	4.22	24,000	7.03	28,800	8.44	927	1,675	2,572	
	7	18			25	14,400	4.22	24,000	7.03	28,800	8.44	927	1,675	2,572	
	9	18			27	14,400	4.22	24,000	7.03	28,800	8.44	927	1,675	2,572	
	12	15			27	14,400	4.22	24,000	7.03	28,800	8.44	927	1,675	2,572	
	5	24			29	14,400	4.22	24,000	7.03	28,800	8.44	927	1,675	2,572	
	12	18			30	14,400	4.22	24,000	7.03	28,800	8.44	927	1,675	2,572	
	15	15			30	14,400	4.22	24,000	7.03	29,000	8.50	927	1,675	2,626	
	7	24			31	14,400	4.22	24,000	7.03	29,000	8.50	927	1,675	2,626	
	9	24			33	14,400	4.22	24,000	7.03	29,000	8.50	927	1,675	2,626	
	15	18			33	14,400	4.22	24,000	7.03	29,000	8.50	927	1,675	2,626	
	18	18			36	14,400	4.22	24,000	7.03	29,000	8.50	927	1,675	2,626	
	12	24			36	14,400	4.22	24,000	7.03	29,000	8.50	927	1,675	2,626	
	3 UNIT	5	5			15	9,000	2.64	15,000	4.40	18,000	5.28	522	916	1,292
		5	5	7		17	10,200	2.99	17,000	4.98	20,400	5.98	607	1,054	1,483
		5	5	9		19	11,400	3.34	19,000	5.57	22,800	6.68	672	1,194	1,680
		5	7	7		19	11,400	3.34	19,000	5.57	22,800	6.68	672	1,194	1,680
5		7	9		21	12,600	3.69	21,000	6.15	25,200	7.39	760	1,338	1,942	
7		7	7		21	12,600	3.69	21,000	6.15	25,200	7.39	760	1,338	1,942	
5		5	12		22	13,200	3.87	22,000	6.45	26,400	7.74	804	1,387	2,079	
5		9	9		23	13,800	4.04	23,000	6.74	27,600	8.09	826	1,461	2,278	
7		7	9		23	13,800	4.04	23,000	6.74	27,600	8.09	826	1,461	2,278	
5		7	12		24	14,400	4.22	24,000	7.03	28,800	8.44	871	1,535	2,442	
5		5	15		25	14,400	4.22	24,000	7.03	28,800	8.44	871	1,535	2,442	
7		9	9		25	14,400	4.22	24,000	7.03	28,800	8.44	871	1,535	2,442	
5		9	12		26	14,400	4.22	24,000	7.03	28,800	8.44	871	1,535	2,442	
7		7	12		26	14,400	4.22	24,000	7.03	28,800	8.44	871	1,535	2,442	
5		7	15		27	14,400	4.22	24,000	7.03	28,800	8.44	871	1,535	2,442	
9		9	9		27	14,400	4.22	24,000	7.03	28,800	8.44	871	1,535	2,442	
7		9	12		28	14,400	4.22	24,000	7.03	28,800	8.44	871	1,535	2,442	
5		5	18		28	14,400	4.22	24,000	7.03	28,800	8.44	871	1,535	2,442	
5		9	15		29	14,400	4.22	24,000	7.03	28,800	8.44	871	1,535	2,442	
5		12	12		29	14,400	4.22	24,000	7.03	28,800	8.44	871	1,535	2,442	
7		7	15		29	14,400	4.22	24,000	7.03	28,800	8.44	871	1,535	2,442	
5		7	18		30	14,400	4.22	24,000	7.03	28,800	8.44	871	1,535	2,442	
9		9	12		30	14,400	4.22	24,000	7.03	28,800	8.44	871	1,535	2,442	
7		7	15		31	14,400	4.22	24,000	7.03	29,000	8.50	871	1,535	2,499	
5		12	12		31	14,400	4.22	24,000	7.03	29,000	8.50	871	1,535	2,499	
5		9	18		32	14,400	4.22	24,000	7.03	29,000	8.50	871	1,535	2,499	
7		7	18		32	14,400	4.22	24,000	7.03	29,000	8.50	871	1,535	2,499	
9		9	15		33	14,400	4.22	24,000	7.03	29,000	8.50	871	1,535	2,499	
9		12	12		33	14,400	4.22	24,000	7.03	29,000	8.50	871	1,535	2,499	
7		9	18		34	14,400	4.22	24,000	7.03	29,000	8.50	871	1,535	2,499	
7		12	15		34	14,400	4.22	24,000	7.03	29,000	8.50	871	1,535	2,499	
5		5	24		34	14,400	4.22	24,000	7.03	29,000	8.50	871	1,535	2,499	
5		12	18		35	14,400	4.22	24,000	7.03	29,000	8.50	871	1,535	2,499	
5		15	15		35	14,400	4.22	24,000	7.03	29,000	8.50	871	1,535	2,499	
5		7	24		36	14,400	4.22	24,000	7.03	29,000	8.50	871	1,535	2,499	
9		12	15		36	14,400	4.22	24,000	7.03	29,000	8.50	871	1,535	2,499	
12	12	12		36	14,400	4.22	24,000	7.03	29,000	8.50	871	1,535	2,499		
9	9	18		36	14,400	4.22	24,000	7.03	29,000	8.50	871	1,535	2,499		
7	12	18		37	14,400	4.22	24,000	7.03	29,000	8.50	871	1,535	2,499		
7	15	15		37	14,400	4.22	24,000	7.03	29,000	8.50	871	1,535	2,499		
5	9	24		38	14,400	4.22	24,000	7.03	29,000	8.50	871	1,535	2,499		
5	15	18		38	14,400	4.22	24,000	7.03	29,000	8.50	871	1,535	2,499		
7	7	24		38	14,400	4.22	24,000	7.03	29,000	8.50	871	1,535	2,499		
9	12	18		39	14,400	4.22	24,000	7.03	29,000	8.50	871	1,535	2,499		
9	15	15		39	14,400	4.22	24,000	7.03	29,000	8.50	871	1,535	2,499		
12	12	15		39	14,400	4.22	24,000	7.03	29,000	8.50	871	1,535	2,499		

Operation	Cooling													
	Combination of Indoor Unit (kBtu/h Class)					Total Capacity						Input(W)		
						Min		Rated		Max		Min	Rated	Max
UNIT-A	UNIT-B	UNIT-C	UNIT-D	Total	Btu/h	kW	Btu/h	kW	Btu/h	kW	Min	Rated	Max	
4 UNIT	5	5	5	5	20	12,000	3.52	20,000	5.86	24,000	7.03	680	1,202	1,677
	5	5	5	7	22	13,200	3.87	22,000	6.45	26,400	7.74	764	1,317	1,975
	5	5	5	9	24	14,400	4.22	24,000	7.03	28,800	8.44	827	1,458	2,274
	5	5	7	7	24	14,400	4.22	24,000	7.03	28,800	8.44	827	1,458	2,274
	5	5	7	9	26	14,400	4.22	24,000	7.03	28,800	8.44	827	1,458	2,274
	5	5	7	7	26	14,400	4.22	24,000	7.03	28,800	8.44	827	1,458	2,274
	5	5	5	12	27	14,400	4.22	24,000	7.03	28,800	8.44	827	1,458	2,274
	5	5	9	9	28	14,400	4.22	24,000	7.03	28,800	8.44	827	1,458	2,274
	5	7	7	9	28	14,400	4.22	24,000	7.03	28,800	8.44	827	1,458	2,274
	5	5	7	7	28	14,400	4.22	24,000	7.03	28,800	8.44	827	1,458	2,274
	5	5	7	12	29	14,400	4.22	24,000	7.03	28,800	8.44	827	1,458	2,274
	5	5	5	15	30	14,400	4.22	24,000	7.03	29,000	8.50	827	1,458	2,317
	5	7	9	9	30	14,400	4.22	24,000	7.03	29,000	8.50	827	1,458	2,317
	7	7	7	9	30	14,400	4.22	24,000	7.03	29,000	8.50	827	1,458	2,317
	5	5	9	12	31	14,400	4.22	24,000	7.03	29,000	8.50	827	1,458	2,317
	5	5	7	12	31	14,400	4.22	24,000	7.03	29,000	8.50	827	1,458	2,317
	5	5	7	15	32	14,400	4.22	24,000	7.03	29,000	8			



# COMBINATION TABLE

## MU4R25

Operation	Combination of Indoor Unit (kBtu/h Class)				Heating						Input(W)			
					Total Capacity									
	UNIT-A	UNIT-B	UNIT-C	UNIT-D	Total	Min	kW	Rated	kW	Max	kW	Min	Rated	Max
1 UNIT	5				5	5,000	1.47	5,500	1.61	6,325	1.85	610	610	714
	7				7	5,500	1.61	8,400	2.46	9,660	2.83	610	636	825
	9				9	6,480	1.90	10,800	3.17	12,420	3.64	610	826	1,077
	12				12	7,920	2.32	13,200	3.87	15,180	4.45	583	1,021	1,338
	15				15	9,900	2.90	16,500	4.84	18,975	5.56	744	1,279	1,744
	18				18	11,880	3.48	19,800	5.80	22,770	6.67	909	1,577	2,133
	24				24	15,240	4.47	25,400	7.44	26,670	7.82	1,192	2,077	2,538
	5	5			10	7,200	2.11	12,000	3.52	14,400	4.22	451	773	1,081
	5	7			12	8,640	2.53	14,400	4.22	17,280	5.06	541	940	1,337
	5	9			14	10,080	2.95	16,800	4.92	20,160	5.91	656	1,112	1,571
	5	7	7		14	10,080	2.95	16,800	4.92	20,160	5.91	656	1,112	1,571
	5	7	9		16	11,520	3.38	19,200	5.63	23,040	6.75	749	1,289	1,844
5	12			17	12,240	3.59	20,400	5.98	24,480	7.17	796	1,392	1,968	
5	9	9		18	12,960	3.80	21,600	6.33	25,920	7.60	844	1,471	2,094	
5	7	12		19	13,680	4.01	22,800	6.68	27,360	8.02	892	1,577	2,222	
5	15			20	14,400	4.22	24,000	7.03	28,800	8.44	940	1,657	2,352	
5	9	12		21	15,120	4.43	25,200	7.39	30,240	8.86	989	1,766	2,568	
5	7	15		22	15,840	4.64	26,400	7.74	31,680	9.28	1,038	1,848	2,811	
5	18			23	16,560	4.85	27,600	8.09	32,000	9.38	1,112	1,960	2,888	
5	15	12		24	17,280	5.06	28,800	8.44	32,000	9.38	1,162	2,045	2,888	
5	7	18		24	17,280	5.06	28,800	8.44	32,000	9.38	1,162	2,045	2,888	
5	9	18		25	17,280	5.06	28,800	8.44	32,000	9.38	1,162	2,045	2,888	
5	12	15		27	17,280	5.06	28,800	8.44	32,000	9.38	1,162	2,045	2,888	
5	24			29	17,280	5.06	28,800	8.44	32,000	9.38	1,162	2,045	2,888	
5	12	18		30	17,280	5.06	28,800	8.44	32,000	9.38	1,162	2,045	2,888	
5	15	15		30	17,280	5.06	28,800	8.44	32,000	9.38	1,162	2,045	2,888	
5	7	24		31	17,280	5.06	28,800	8.44	32,000	9.38	1,162	2,045	2,888	
5	9	24		33	17,280	5.06	28,800	8.44	32,000	9.38	1,162	2,045	2,888	
5	15	18		33	17,280	5.06	28,800	8.44	32,000	9.38	1,162	2,045	2,888	
5	18	18		36	17,280	5.06	28,800	8.44	32,000	9.38	1,162	2,045	2,888	
5	12	24		36	17,280	5.06	28,800	8.44	32,000	9.38	1,162	2,045	2,888	
5	5	5	5	15	10,800	3.17	18,000	5.28	21,600	6.33	660	1,140	1,590	
5	5	7	7	17	12,240	3.59	20,400	5.98	24,480	7.17	748	1,309	1,850	
5	5	9	9	19	13,680	4.01	22,800	6.68	27,360	8.02	838	1,482	2,089	
5	5	7	7	19	13,680	4.01	22,800	6.68	27,360	8.02	838	1,482	2,089	
5	5	7	9	21	15,120	4.43	25,200	7.39	30,240	8.86	930	1,660	2,414	
5	5	7	7	21	15,120	4.43	25,200	7.39	30,240	8.86	930	1,660	2,414	
5	5	5	12	22	15,840	4.64	26,400	7.74	31,680	9.28	976	1,738	2,590	
5	5	9	9	23	16,560	4.85	27,600	8.09	32,000	9.38	1,046	1,842	2,633	
5	7	7	9	23	16,560	4.85	27,600	8.09	32,000	9.38	1,046	1,842	2,633	
5	7	12		24	17,280	5.06	28,800	8.44	32,000	9.38	1,093	1,922	2,633	
5	5	5	15	25	17,280	5.06	28,800	8.44	32,000	9.38	1,093	1,922	2,633	
5	7	9	9	25	17,280	5.06	28,800	8.44	32,000	9.38	1,093	1,922	2,633	
5	9	9	12	26	17,280	5.06	28,800	8.44	32,000	9.38	1,093	1,922	2,633	
5	7	7	12	26	17,280	5.06	28,800	8.44	32,000	9.38	1,093	1,922	2,633	
5	7	15		27	17,280	5.06	28,800	8.44	32,000	9.38	1,093	1,922	2,633	
5	9	9	9	27	17,280	5.06	28,800	8.44	32,000	9.38	1,093	1,922	2,633	
5	7	9	12	28	17,280	5.06	28,800	8.44	32,000	9.38	1,093	1,922	2,633	
5	5	5	18	28	17,280	5.06	28,800	8.44	32,000	9.38	1,093	1,922	2,633	
5	5	9	15	29	17,280	5.06	28,800	8.44	32,000	9.38	1,093	1,922	2,633	
5	5	12	12	29	17,280	5.06	28,800	8.44	32,000	9.38	1,093	1,922	2,633	
5	7	7	15	29	17,280	5.06	28,800	8.44	32,000	9.38	1,093	1,922	2,633	
5	7	18		30	17,280	5.06	28,800	8.44	32,000	9.38	1,093	1,922	2,633	
5	9	9	12	30	17,280	5.06	28,800	8.44	32,000	9.38	1,093	1,922	2,633	
5	7	9	15	31	17,280	5.06	28,800	8.44	32,000	9.38	1,093	1,922	2,633	
5	12	12		31	17,280	5.06	28,800	8.44	32,000	9.38	1,093	1,922	2,633	
5	5	12	15	32	17,280	5.06	28,800	8.44	32,000	9.38	1,093	1,922	2,633	
5	9	9	18	32	17,280	5.06	28,800	8.44	32,000	9.38	1,093	1,922	2,633	
5	7	7	18	32	17,280	5.06	28,800	8.44	32,000	9.38	1,093	1,922	2,633	
5	9	9	15	33	17,280	5.06	28,800	8.44	32,000	9.38	1,093	1,922	2,633	
5	9	12	12	33	17,280	5.06	28,800	8.44	32,000	9.38	1,093	1,922	2,633	
5	7	9	18	34	17,280	5.06	28,800	8.44	32,000	9.38	1,093	1,922	2,633	
5	7	12	15	34	17,280	5.06	28,800	8.44	32,000	9.38	1,093	1,922	2,633	
5	5	5	24	34	17,280	5.06	28,800	8.44	32,000	9.38	1,093	1,922	2,633	
5	12	18		35	17,280	5.06	28,800	8.44	32,000	9.38	1,093	1,922	2,633	
5	15	15		35	17,280	5.06	28,800	8.44	32,000	9.38	1,093	1,922	2,633	
5	7	24		36	17,280	5.06	28,800	8.44	32,000	9.38	1,093	1,922	2,633	
5	9	12	15	36	17,280	5.06	28,800	8.44	32,000	9.38	1,093	1,922	2,633	
12	12	12		36	17,280	5.06	28,800	8.44	32,000	9.38	1,093	1,922	2,633	
9	9	9	18	36	17,280	5.06	28,800	8.44	32,000	9.38	1,093	1,922	2,633	
7	12	18		37	17,280	5.06	28,800	8.44	32,000	9.38	1,093	1,922	2,633	
7	15	15		37	17,280	5.06	28,800	8.44	32,000	9.38	1,093	1,922	2,633	
5	9	24		38	17,280	5.06	28,800	8.44	32,000	9.38	1,093	1,922	2,633	
5	15	18		38	17,280	5.06	28,800	8.44	32,000	9.38	1,093	1,922	2,633	
7	7	24		38	17,280	5.06	28,800	8.44	32,000	9.38	1,093	1,922	2,633	
9	12	18		39	17,280	5.06	28,800	8.44	32,000	9.38	1,093	1,922	2,633	
9	15	15		39	17,280	5.06	28,800	8.44	32,000	9.38	1,093	1,922	2,633	
12	12	15		39	17,280	5.06	28,800	8.44	32,000	9.38	1,093	1,922	2,633	

Operation	Combination of Indoor Unit (kBtu/h Class)				Heating						Input(W)			
					Total Capacity									
	UNIT-A	UNIT-B	UNIT-C	UNIT-D	Total	Min	kW	Rated	kW	Max	kW	Min	Rated	Max
4 UNIT	5	5			20	14,400	4.22	24,000	7.03	28,800	8.44	840	1,480	2,100
	5	5	5	7	22	15,840	4.64	26,400	7.74	31,680	9.28	927	1,651	2,470
	5	5	5	9	24	17,280	5.06	28,800	8.44	32,000	9.38	1,038	1,826	2,517
	5	5	7	7	24	17,280	5.06	28,800	8.44	32,000	9.38	1,038	1,826	2,517
	5	5	7	9	26	17,280	5.06	28,800	8.44	32,000	9.38	1,038	1,826	2,517
	5	7	7	7	26	17,280	5.06	28,800	8.44	32,000	9.38	1,038	1,826	2,517
	5	5	5	12	27	17,280	5.06	28,800	8.44	32,000	9.38	1,038	1,826	2,517
	5	5	9	9	28	17,280	5.06	28,800	8.44	32,000	9.38	1,038	1,826	2,517
	5	7	7	9	28	17,280	5.06	28,800	8.44	32,000	9.38	1,038	1,826	2,517
	7	7	7	7	28	17,280	5.06	28,800	8.44	32,000	9.38	1,038	1,826	2,517
	5	5	5	12	29	17,280	5.06	28,800	8.44	32,000	9.38	1,038	1,826	2,517
	5	5	5	15	30	17,280	5.06	28,800	8.44	32,000	9.38	1,038	1,826	2,517
	5	7	7	9	30	17,280	5.06	28,800	8.44	32,000	9.38	1,038	1,826	2,517
	7	7	7	9	30	17,280	5.06	28,800	8.44	32,000	9.38	1,038	1,826	2,517
	5	5	9	12	31	17,280	5.06	28,800	8.44	32,000	9.38	1,038	1,826	2,517
	5	7	7	12	31	17,280	5.06	28,800	8.44	32,000	9.38	1,038		

# COMBINATION TABLE

## MU4R27

Operation	Cooling											Input(W)			
	Combination of Indoor Unit (kBtu/h Class)					Total Capacity									
	UNIT-A	UNIT-B	UNIT-C	UNIT-D	Total	Min		Rated		Max		Min	Rated	Max	
1 UNIT	5				5	4,500	1.32	5,000	1.47	6,000	1.76	416	418	612	
	7				7	4,800	1.41	7,000	2.05	8,400	2.46	416	494	663	
	9				9	5,400	1.58	9,000	2.64	10,800	3.17	416	617	861	
	12				12	7,200	2.11	12,000	3.52	14,400	4.22	494	846	1,153	
	15				15	8,520	2.50	14,200	4.16	17,040	4.99	592	1,029	1,395	
	18				18	10,800	3.17	18,000	5.28	21,600	6.33	769	1,328	1,804	
	24				24	14,400	4.22	24,000	7.03	25,500	7.47	1,029	1,815	2,536	
	5	5			10	6,000	1.76	10,000	2.93	12,000	3.52	378	623	853	
	5	7			12	7,200	2.11	12,000	3.52	14,400	4.22	444	761	1,038	
	5	9			14	8,400	2.46	14,000	4.10	16,800	4.92	533	903	1,228	
2 UNIT	5	5			10	6,000	1.76	10,000	2.93	12,000	3.52	378	623	853	
	5	7			12	7,200	2.11	12,000	3.52	14,400	4.22	444	761	1,038	
	5	9			14	8,400	2.46	14,000	4.10	16,800	4.92	533	903	1,228	
	7	7			14	8,400	2.46	14,000	4.10	16,800	4.92	533	903	1,228	
	7	9			16	9,600	2.89	16,000	4.69	19,200	5.63	601	1,047	1,423	
	5	12			17	10,200	2.99	17,000	4.98	20,400	5.98	646	1,121	1,537	
	9	9			18	10,800	3.17	18,000	5.28	21,600	6.33	692	1,195	1,623	
	7	12			19	11,400	3.34	19,000	5.57	22,800	6.68	715	1,270	1,740	
	5	15			20	12,000	3.52	20,000	5.86	24,000	7.03	761	1,347	1,829	
	9	12			21	12,600	3.69	21,000	6.15	25,200	7.39	808	1,423	2,012	
	7	15			22	13,200	3.87	22,000	6.45	26,400	7.74	855	1,475	2,154	
	5	18			23	13,800	4.04	23,000	6.74	27,600	8.09	879	1,554	2,351	
	9	15			24	14,400	4.22	24,000	7.03	28,800	8.44	927	1,633	2,505	
	12	12			24	14,400	4.22	24,000	7.03	28,800	8.44	927	1,633	2,505	
	7	18			25	15,000	4.40	25,000	7.33	30,000	8.79	975	1,755	2,721	
	9	18			27	16,200	4.75	27,000	7.91	31,050	9.10	1,047	2,011	2,891	
	12	15			27	16,200	4.75	27,000	7.91	31,050	9.10	1,047	2,011	2,891	
	5	24			29	16,200	4.75	27,000	7.91	31,050	9.10	1,047	2,011	2,891	
	12	18			30	16,200	4.75	27,000	7.91	31,050	9.10	1,047	2,011	2,891	
	15	15			30	16,200	4.75	27,000	7.91	31,050	9.10	1,047	2,011	2,891	
	7	24			31	16,200	4.75	27,000	7.91	31,050	9.10	1,047	2,011	2,891	
	9	24			33	16,200	4.75	27,000	7.91	31,050	9.10	1,047	2,011	2,891	
	15	18			33	16,200	4.75	27,000	7.91	31,050	9.10	1,047	2,011	2,891	
	18	18			36	16,200	4.75	27,000	7.91	31,050	9.10	1,047	2,011	2,891	
	12	24			36	16,200	4.75	27,000	7.91	31,050	9.10	1,047	2,011	2,891	
	15	24			39	16,200	4.75	27,000	7.91	31,050	9.10	1,047	2,011	2,891	
	3 UNIT	5	5			15	9,000	2.64	15,000	4.40	18,000	5.28	522	916	1,258
		5	5	7		17	10,200	2.99	17,000	4.98	20,400	5.98	607	1,054	1,445
		5	5	9		19	11,400	3.34	19,000	5.57	22,800	6.68	672	1,194	1,636
		5	7	7		19	11,400	3.34	19,000	5.57	22,800	6.68	672	1,194	1,636
5		7	9		21	12,600	3.69	21,000	6.15	25,200	7.39	760	1,338	1,891	
7		7	7		21	12,600	3.69	21,000	6.15	25,200	7.39	760	1,338	1,891	
5		5	12		22	13,200	3.87	22,000	6.45	26,400	7.74	804	1,387	2,025	
5		9	9		23	13,800	4.04	23,000	6.74	27,600	8.09	826	1,461	2,219	
7		7	9		23	13,800	4.04	23,000	6.74	27,600	8.09	826	1,461	2,219	
5		7	12		24	14,400	4.22	24,000	7.03	28,800	8.44	871	1,535	2,379	
5		5	15		25	15,000	4.40	25,000	7.33	30,000	8.79	916	1,650	2,605	
7		9	9		25	15,000	4.40	25,000	7.33	30,000	8.79	916	1,650	2,605	
5		9	12		26	15,600	4.57	26,000	7.62	31,200	9.14	962	1,767	2,784	
7		7	12		26	15,600	4.57	26,000	7.62	31,200	9.14	962	1,767	2,784	
5		7	15		27	16,200	4.75	27,000	7.91	31,050	9.10	984	1,890	2,784	
9		9	9		27	16,200	4.75	27,000	7.91	31,050	9.10	984	1,890	2,784	
7		9	12		28	16,200	4.75	27,000	7.91	31,050	9.10	984	1,890	2,784	
5		5	18		28	16,200	4.75	27,000	7.91	31,050	9.10	984	1,890	2,784	
5		9	15		29	16,200	4.75	27,000	7.91	31,050	9.10	984	1,890	2,784	
5		12	12		29	16,200	4.75	27,000	7.91	31,050	9.10	984	1,890	2,784	
7		7	15		29	16,200	4.75	27,000	7.91	31,050	9.10	984	1,890	2,784	
5		7	18		30	16,200	4.75	27,000	7.91	31,050	9.10	984	1,890	2,784	
9		9	12		30	16,200	4.75	27,000	7.91	31,050	9.10	984	1,890	2,784	
7		9	15		31	16,200	4.75	27,000	7.91	31,050	9.10	984	1,890	2,784	
7		12	12		31	16,200	4.75	27,000	7.91	31,050	9.10	984	1,890	2,784	
5		12	15		32	16,200	4.75	27,000	7.91	31,050	9.10	984	1,890	2,784	
5		9	18		32	16,200	4.75	27,000	7.91	31,050	9.10	984	1,890	2,784	
7		7	18		32	16,200	4.75	27,000	7.91	31,050	9.10	984	1,890	2,784	
9		9	15		33	16,200	4.75	27,000	7.91	31,050	9.10	984	1,890	2,784	
9		12	12		33	16,200	4.75	27,000	7.91	31,050	9.10	984	1,890	2,784	
7		9	18		34	16,200	4.75	27,000	7.91	31,050	9.10	984	1,890	2,784	
7		12	15		34	16,200	4.75	27,000	7.91	31,050	9.10	984	1,890	2,784	
5		5	24		34	16,200	4.75	27,000	7.91	31,050	9.10	984	1,890	2,784	
5		12	18		35	16,200	4.75	27,000	7.91	31,050	9.10	984	1,890	2,784	
5		15	15		35	16,200	4.75	27,000	7.91	31,050	9.10	984	1,890	2,784	
5		7	24		36	16,200	4.75	27,000	7.91	31,050	9.10	984	1,890	2,784	
9		12	15		36	16,200	4.75	27,000	7.91	31,050	9.10	984	1,890	2,784	
12		12	12		36	16,200	4.75	27,000	7.91	31,050	9.10	984	1,890	2,784	
9		9	18		36	16,200	4.75	27,000	7.91	31,050	9.10	984	1,890	2,784	
7		12	18		37	16,200	4.75	27,000	7.91	31,050	9.10	984	1,890	2,784	
7		15	15		37	16,200	4.75	27,000	7.91	31,050	9.10	984	1,890	2,784	
5		9	24		38	16,200	4.75	27,000	7.91	31,050	9.10	984	1,890	2,784	
5		15	18		38	16,200	4.75	27,000	7.91	31,050	9.10	984	1,890	2,784	
9		15	15		39	16,200	4.75	27,000	7.91	31,050	9.10	984	1,890	2,784	
12		12	15		39	16,200	4.75	27,000	7.91	31,050	9.10	984	1,890	2,784	
7		9	24		40	16,200	4.75	27,000	7.91	31,050	9.10	984	1,890	2,784	
7		15	18		40	16,200	4.75	27,000	7.91	31,050	9.10	984	1,890	2,784	
5		12	24		41	16,200	4.75	27,000	7.91	31,050	9.10	984	1,890	2,784	
5		18	18		41	16,200	4.75	27,000	7.91	31,050	9.10	984	1,890	2,784	

Operation	Cooling											Input(W)		
	Combination of Indoor Unit (kBtu/h Class)					Total Capacity								
	UNIT-A	UNIT-B	UNIT-C	UNIT-D	Total	Min		Rated		Max		Min	Rated	Max
1 UNIT	5				5	4,500	1.32	5,000	1.47	6,000	1.76	416	418	612
	7				7	4,800	1.41	7,000	2.05	8,400	2.46	416	494	663
	9				9	5,400	1.58	9,000	2.64	10,800	3.17	416	617	861
	12				12	7,200	2.11	12,000	3.52	14,400	4.22	494	846	1,153
	15				15	8,520	2.50	14,200	4.16	17,040	4.99	592	1,029	1,395
	18				18	10,800	3.17	18,000	5.28	21,600	6.33	769	1,328	1,804
	24				24	14,400	4.22	24,000	7.03	25,500	7.47	1,029	1,815	2,536
	5	5			10	6,000	1.76	10,000	2.93	12,000	3.52	378	623	853
	5	7			12	7,200	2.11	12,000	3.52	14,400	4.22	444	761	1,038
	5	9			14	8,400	2.46	14,000	4.10	16,800	4.92	533	903	1,228
2 UNIT	5	5			10	6,000	1.76	10,000	2.93	12,000	3.52	378	623	853
	5	7			12	7,200	2.11	12,000	3.52	14,400	4.22	444	761	1,

# COMBINATION TABLE

## MU4R27

Operation	Combination of Indoor Unit (kBtu/h Class)					Heating						Input(W)		
						Total Capacity								
	UNIT-A	UNIT-B	UNIT-C	UNIT-D	Total	Min		Rated		Max		Min	Rated	Max
1 UNIT	5				5	5,000	1.47	5,500	1.61	6,325	1.85	610	610	714
	7				7	5,400	1.58	5,900	1.72	6,725	1.96	610	636	825
	9				9	6,480	1.90	7,080	2.17	8,100	2.39	610	826	1,077
	12				12	7,920	2.32	8,640	2.63	9,720	2.87	583	1,021	1,338
	15				15	9,900	2.90	10,800	3.37	12,420	3.64	583	1,021	1,338
	18				18	11,880	3.48	13,000	4.84	15,180	4.45	744	1,279	1,744
	24				24	15,240	4.47	16,500	5.80	18,975	5.56	909	1,577	2,133
	5	5			10	7,200	2.11	7,800	2.35	8,640	2.63	451	773	1,081
	5	7			12	8,640	2.53	9,400	2.87	10,440	3.11	541	940	1,337
	5	9			14	10,080	2.95	11,000	3.31	12,240	3.55	656	1,112	1,571
	5	12			16	12,240	3.37	13,400	3.95	15,180	4.19	844	1,471	2,094
	5	15			19	14,400	3.79	15,800	4.63	17,760	4.87	1,112	1,744	2,391
	5	18			24	18,000	4.95	20,000	5.80	22,770	5.80	1,192	2,077	2,538
	5	24			30	24,000	6.60	26,000	7.80	30,240	7.80	1,192	2,077	2,538
	2 UNIT	5	5			10	10,080	2.95	11,000	3.31	12,240	3.55	656	1,112
5		7			12	12,240	3.37	13,400	3.95	15,180	4.19	744	1,279	1,744
5		9			14	14,400	3.79	15,800	4.63	17,760	4.87	909	1,577	2,133
5		12			16	16,560	4.47	18,000	5.45	20,160	5.56	1,192	2,077	2,538
5		15			19	19,200	5.63	20,400	5.98	24,480	6.12	1,192	2,077	2,538
5		18			24	24,000	7.80	26,000	7.80	30,240	7.80	1,192	2,077	2,538
5		5	5		10	12,240	3.37	13,400	3.95	15,180	4.19	744	1,279	1,744
5		7	5		12	13,680	4.01	14,400	4.22	16,560	4.43	909	1,577	2,133
5		9	5		14	15,120	4.43	16,000	4.92	17,280	4.92	1,112	1,571	1,960
5		12	5		16	17,280	5.06	18,000	5.45	20,160	5.56	1,192	2,077	2,538
5		15	5		18	19,440	5.69	20,400	5.98	24,480	6.12	1,192	2,077	2,538
5		18	5		24	24,000	7.80	26,000	7.80	30,240	7.80	1,192	2,077	2,538
5		5	7		12	15,120	4.43	16,000	4.92	17,280	4.92	1,112	1,571	1,960
5		7	7		14	17,280	5.06	18,000	5.45	20,160	5.56	1,192	2,077	2,538
5		9	7		16	19,440	5.69	20,400	5.98	24,480	6.12	1,192	2,077	2,538
5		12	7		18	21,600	6.33	22,800	6.68	27,360	6.82	1,192	2,077	2,538
5		15	7		20	24,000	7.80	26,000	7.80	30,240	7.80	1,192	2,077	2,538
5		18	7		24	28,800	9.90	30,000	9.90	34,100	9.90	1,192	2,077	2,538
5		5	9		14	18,000	5.45	19,000	6.09	21,600	6.33	1,147	2,194	2,998
5		7	9		16	21,600	6.33	22,800	6.68	27,360	6.82	1,194	2,157	3,384
5		9	9		18	25,200	7.39	26,400	7.74	31,680	7.98	1,194	2,157	3,384
5		12	9		20	30,000	9.09	31,000	9.09	34,100	9.09	1,194	2,157	3,384
5		15	9		24	36,000	11.72	38,000	12.36	43,200	12.36	1,194	2,157	3,384
5		18	9		24	36,000	11.72	38,000	12.36	43,200	12.36	1,194	2,157	3,384
5		5	12		17	18,000	5.45	19,000	6.09	21,600	6.33	1,147	2,194	2,998
5		7	12		19	21,600	6.33	22,800	6.68	27,360	6.82	1,194	2,157	3,384
5		9	12		21	25,200	7.39	26,400	7.74	31,680	7.98	1,194	2,157	3,384
5		12	12		24	30,000	9.09	31,000	9.09	34,100	9.09	1,194	2,157	3,384
5		15	12		24	36,000	11.72	38,000	12.36	43,200	12.36	1,194	2,157	3,384
5		18	12		24	36,000	11.72	38,000	12.36	43,200	12.36	1,194	2,157	3,384
5		5	15		20	24,000	7.80	26,000	7.80	30,240	7.80	1,194	2,157	3,384
5		7	15		22	28,800	9.90	30,000	9.90	34,100	9.90	1,194	2,157	3,384
5		9	15		24	36,000	11.72	38,000	12.36	43,200	12.36	1,194	2,157	3,384
5	12	15		24	36,000	11.72	38,000	12.36	43,200	12.36	1,194	2,157	3,384	
5	15	15		24	36,000	11.72	38,000	12.36	43,200	12.36	1,194	2,157	3,384	
5	18	15		24	36,000	11.72	38,000	12.36	43,200	12.36	1,194	2,157	3,384	
5	5	18		23	25,200	7.39	26,400	7.74	31,680	7.98	1,147	2,194	2,998	
5	7	18		25	28,800	8.44	28,800	8.44	34,100	8.44	1,147	2,194	2,998	
5	9	18		27	32,400	9.49	30,000	9.49	34,100	9.49	1,147	2,194	2,998	
5	12	18		27	36,000	11.72	38,000	12.36	43,200	12.36	1,147	2,194	2,998	
5	15	18		27	36,000	11.72	38,000	12.36	43,200	12.36	1,147	2,194	2,998	
5	18	18		27	36,000	11.72	38,000	12.36	43,200	12.36	1,147	2,194	2,998	
5	5	24		29	36,000	11.72	38,000	12.36	43,200	12.36	1,147	2,194	2,998	
5	7	24		31	40,800	13.86	42,000	14.50	48,000	14.50	1,147	2,194	2,998	
5	9	24		33	44,400	15.90	44,400	16.54	50,400	16.54	1,147	2,194	2,998	
5	12	24		36	54,000	19.44	54,000	20.98	60,000	20.98	1,147	2,194	2,998	
5	15	24		39	63,000	23.18	63,000	24.72	70,000	24.72	1,147	2,194	2,998	
5	5	5	5	15	15,120	4.43	16,000	4.92	17,280	4.92	930	1,660	2,414	
5	7	5	5	17	17,280	5.06	18,000	5.45	20,160	5.56	930	1,660	2,414	
5	9	5	5	19	19,440	5.69	20,400	5.98	24,480	6.12	976	1,738	2,590	
5	12	5	5	21	21,600	6.33	22,800	6.68	27,360	6.82	1,046	1,842	2,767	
5	15	5	5	23	24,000	7.80	26,000	7.80	30,240	7.80	1,046	1,842	2,767	
5	18	5	5	24	28,800	9.90	30,000	9.90	34,100	9.90	1,093	1,922	2,951	
5	5	7	7	19	21,600	6.33	22,800	6.68	27,360	6.82	1,140	2,063	2,998	
5	7	7	7	21	25,200	7.39	26,400	7.74	31,680	7.98	1,140	2,063	2,998	
5	9	7	7	23	28,800	8.44	28,800	8.44	34,100	8.44	1,140	2,063	2,998	
5	12	7	7	25	32,400	9.49	30,000	9.49	34,100	9.49	1,140	2,063	2,998	
5	15	7	7	27	36,000	11.72	38,000	12.36	43,200	12.36	1,188	2,177	2,998	
5	18	7	7	27	36,000	11.72	38,000	12.36	43,200	12.36	1,188	2,177	2,998	
5	5	9	9	21	25,200	7.39	26,400	7.74	31,680	7.98	1,188	2,177	2,998	
5	7	9	9	23	28,800	8.44	28,800	8.44	34,100	8.44	1,188	2,177	2,998	
5	9	9	9	25	32,400	9.49	30,000	9.49	34,100	9.49	1,188	2,177	2,998	
5	12	9	9	27	36,000	11.72	38,000	12.36	43,200	12.36	1,188	2,177	2,998	
5	15	9	9	27	36,000	11.72	38,000	12.36	43,200	12.36	1,188	2,177	2,998	
5	18	9	9	27	36,000	11.72	38,000	12.36	43,200	12.36	1,188	2,177	2,998	
5	5	12	12	21	25,200	7.39	26,400	7.74	31,680	7.98	1,188	2,177	2,998	
5	7	12	12	23	28,800	8.44	28,800	8.44	34,100	8.44	1,188	2,177	2,998	
5	9	12	12	25	32,400	9.49	30,000	9.49	34,100	9.49	1,188	2,177	2,998	
5	12	12	12	27	36,000	11.72	38,000	12.36	43,200	12.36	1,188	2,177	2,998	
5	15	12	12	27	36,000	11.72	38,000	12.36	43,200	12.36	1,188	2,177	2,998	
5	18	12	12	27	36,000	11.72	38,000	12.36	43,200	12.36	1,188	2,177	2,998	
5	5	15	15	21	25,200	7.39	26,400	7.74	31,680	7.98	1,188	2,177	2,998	
5	7	15	15	23	28,800	8.44	28,800	8.44	34,100	8.44	1,188	2,177	2,998	
5	9	15	15	25	32,400	9.49	30,000	9.49	34,100	9.49	1,188	2,177	2,998	
5	12	15	15	27	36,000	11.72	38,000	12.36	43,200	12.36	1,188	2,177	2,998	
5	15	15	15	27	36,000	11.72	38,000	12.36	43,200	12.36	1,188	2,177	2,998	
5	18	15	15	27	36,000	11.72	38,000	12.36	43,200	12.36	1,188	2,177	2,998	
5	5	18	18	21	25,200	7.39	26,400	7.74	31,680	7.98	1,188	2,177	2,998	
5	7	18	18	23	28,800	8.44	28,800	8.44	34,100	8.44	1,188	2,177	2,998	
5	9	18	18	25	32,400	9.49	30,000	9.49	34,100	9.49	1,188	2,177	2,998	
5	12	18	18	27	36,000	11.72	38,000	12.36	43,200	12.36	1,188	2,177	2,998	
5	15	18	18	27	36,000	11.72	38,000	12						

# COMBINATION TABLE

## MU5R30

Operation	Cooling														
	Combination of Indoor Unit (kBtu/h Class)						Total Capacity						Input(W)		
	UNIT-A	UNIT-B	UNIT-C	UNIT-D	UNIT-E	Total	Min		Rated		Max		Min	Rated	Max
						Btu/h	kW	Btu/h	kW	Btu/h	kW				
1 UNIT	5					5	4,500	1.32	5,000	1.47	6,000	1.76	416	418	629
	7					7	4,800	1.41	7,000	2.05	8,400	2.46	416	494	681
	9					9	5,400	1.58	9,000	2.64	10,800	3.17	416	617	884
	12					12	7,200	2.11	12,000	3.52	14,400	4.22	494	846	1,184
	15					15	8,520	2.50	14,200	4.16	17,040	4.99	592	1,029	1,432
	18					18	10,800	3.17	18,000	5.28	21,600	6.33	769	1,328	1,852
	24					24	14,400	4.22	24,000	7.03	25,500	7.47	1,029	1,815	2,604
	5	5				10	6,000	1.76	10,000	2.93	12,000	3.52	378	623	876
	7	7				12	7,200	2.11	12,000	3.52	14,400	4.22	444	761	1,066
	9	9				14	8,400	2.46	14,000	4.10	16,800	4.92	533	903	1,261
2 UNIT	7	7				14	8,400	2.46	14,000	4.10	16,800	4.92	533	903	1,261
	7	9				16	9,600	2.81	16,000	4.69	19,200	5.63	601	1,047	1,461
	9	12				17	10,200	2.99	17,000	4.98	20,400	5.98	646	1,121	1,578
	9	9				18	10,800	3.17	18,000	5.28	21,600	6.33	692	1,195	1,667
	9	12				19	11,400	3.34	19,000	5.57	22,800	6.68	715	1,270	1,787
	5	15				20	12,000	3.52	20,000	5.86	24,000	7.03	761	1,347	1,878
	9	12				21	12,600	3.69	21,000	6.15	25,200	7.39	808	1,423	2,066
	7	15				22	13,200	3.87	22,000	6.45	26,400	7.74	855	1,475	2,211
	5	18				23	13,800	4.04	23,000	6.74	27,600	8.09	879	1,554	2,414
	9	15				24	14,400	4.22	24,000	7.03	28,800	8.44	927	1,633	2,572
	12	12				24	14,400	4.22	24,000	7.03	28,800	8.44	927	1,633	2,572
	7	18				25	15,000	4.40	25,000	7.33	30,000	8.79	975	1,755	2,794
	9	18				27	16,200	4.75	27,000	7.91	32,400	9.50	1,047	2,011	3,213
	12	15				27	16,200	4.75	27,000	7.91	32,400	9.50	1,047	2,011	3,213
	5	24				29	17,400	5.10	29,000	8.50	33,000	9.67	1,145	2,284	3,341
	12	18				30	18,000	5.28	30,000	8.79	33,000	9.67	1,195	2,429	3,341
	15	15				30	18,000	5.28	30,000	8.79	33,000	9.67	1,195	2,429	3,341
	7	24				31	18,000	5.28	30,000	8.79	33,000	9.67	1,195	2,429	3,341
	9	24				33	18,000	5.28	30,000	8.79	33,000	9.67	1,195	2,429	3,341
	15	18				33	18,000	5.28	30,000	8.79	33,000	9.67	1,195	2,429	3,341
	18	18				36	18,000	5.28	30,000	8.79	33,000	9.67	1,195	2,429	3,341
	12	24				36	18,000	5.28	30,000	8.79	33,000	9.67	1,195	2,429	3,341
	15	24				39	18,000	5.28	30,000	8.79	33,000	9.67	1,195	2,429	3,341
	18	24				42	18,000	5.28	30,000	8.79	33,000	9.67	1,195	2,429	3,341
	24	24				48	18,000	5.28	30,000	8.79	33,000	9.67	1,195	2,429	3,341
	5	5	5			15	9,000	2.64	15,000	4.40	18,000	5.28	522	916	1,292
	5	7				17	10,200	2.99	17,000	4.98	20,400	5.98	607	1,054	1,483
	5	9				19	11,400	3.34	19,000	5.57	22,800	6.68	672	1,194	1,680
	5	7	7			19	11,400	3.34	19,000	5.57	22,800	6.68	672	1,194	1,680
	5	7	9			21	12,600	3.69	21,000	6.15	25,200	7.39	760	1,338	1,942
	7	7	7			21	12,600	3.69	21,000	6.15	25,200	7.39	760	1,338	1,942
	5	9	9			22	13,200	3.87	22,000	6.45	26,400	7.74	804	1,387	2,079
	5	5	12			23	13,800	4.04	23,000	6.74	27,600	8.09	826	1,461	2,278
	7	7	9			23	13,800	4.04	23,000	6.74	27,600	8.09	826	1,461	2,278
	5	7	12			24	14,400	4.22	24,000	7.03	28,800	8.44	871	1,535	2,442
	5	9	15			25	15,000	4.40	25,000	7.33	30,000	8.79	916	1,650	2,674
	7	9	9			25	15,000	4.40	25,000	7.33	30,000	8.79	916	1,650	2,674
	5	9	12			26	15,600	4.57	26,000	7.62	31,200	9.14	962	1,767	2,859
	7	7	12			26	15,600	4.57	26,000	7.62	31,200	9.14	962	1,767	2,859
	5	9	15			27	16,200	4.75	27,000	7.91	32,400	9.50	984	1,890	3,120
9	9	9			27	16,200	4.75	27,000	7.91	32,400	9.50	984	1,890	3,120	
7	9	12			28	16,800	4.92	28,000	8.21	33,600	9.85	1,030	2,028	3,327	
5	18				28	16,800	4.92	28,000	8.21	33,600	9.85	1,030	2,028	3,327	
5	12	12			29	17,400	5.10	29,000	8.50	33,600	9.85	1,077	2,173	3,327	
7	7	15			29	17,400	5.10	29,000	8.50	33,600	9.85	1,077	2,173	3,327	
5	7	18			30	18,000	5.28	30,000	8.79	33,600	9.85	1,123	2,326	3,327	
9	9	12			30	18,000	5.28	30,000	8.79	33,600	9.85	1,123	2,326	3,327	
7	9	15			31	18,000	5.28	30,000	8.79	33,600	9.85	1,123	2,326	3,327	
5	12	15			32	18,000	5.28	30,000	8.79	33,600	9.85	1,123	2,326	3,327	
7	12	12			32	18,000	5.28	30,000	8.79	33,600	9.85	1,123	2,326	3,327	
5	12	15			32	18,000	5.28	30,000	8.79	33,600	9.85	1,123	2,326	3,327	
7	7	18			32	18,000	5.28	30,000	8.79	33,600	9.85	1,123	2,326	3,327	
9	9	15			33	18,000	5.28	30,000	8.79	33,600	9.85	1,123	2,326	3,327	
9	12	12			33	18,000	5.28	30,000	8.79	33,600	9.85	1,123	2,326	3,327	
7	9	18			34	18,000	5.28	30,000	8.79	33,600	9.85	1,123	2,326	3,327	
5	12	15			34	18,000	5.28	30,000	8.79	33,600	9.85	1,123	2,326	3,327	
5	15	18			35	18,000	5.28	30,000	8.79	33,600	9.85	1,123	2,326	3,327	
5	7	24			35	18,000	5.28	30,000	8.79	33,600	9.85	1,123	2,326	3,327	
9	12	15			36	18,000	5.28	30,000	8.79	33,600	9.85	1,123	2,326	3,327	
12	12	12			36	18,000	5.28	30,000	8.79	33,600	9.85	1,123	2,326	3,327	
9	9	18			36	18,000	5.28	30,000	8.79	33,600	9.85	1,123	2,326	3,327	
7	12	18			37	18,000	5.28	30,000	8.79	33,600	9.85	1,123	2,326	3,327	
7	15	15			37	18,000	5.28	30,000	8.79	33,600	9.85	1,123	2,326	3,327	
5	9	24			38	18,000	5.28	30,000	8.79	33,600	9.85	1,123	2,326	3,327	
5	15	18			38	18,000	5.28	30,000	8.79	33,600	9.85	1,123	2,326	3,327	
7	7	24			38	18,000	5.28	30,000	8.79	33,600	9.85	1,123	2,326	3,327	
9	12	18			39	18,000	5.28	30,000	8.79	33,600	9.85	1,123	2,326	3,327	
9	15	15			39	18,000	5.28	30,000	8.79	33,600	9.85	1,123	2,326	3,327	
12	12	15			39	18,000	5.28	30,000	8.79	33,600	9.85	1,123	2,326	3,327	
7	9	24			40	18,000	5.28	30,000	8.79	33,600	9.85	1,123	2,326	3,327	
7	15	18			40	18,000	5.28	30,000	8.79	33,600	9.85	1,123	2,326	3,327	
5	12	24			41	18,000	5.28	30,000	8.79	33,600	9.85	1,123	2,326	3,327	
5	18	18			41	18,000	5.28	30,000	8.79	33,600	9.85	1,123	2,326	3,327	
12	12	18			42	18,000	5.28	30,000	8.79	33,600	9.85	1,123	2,326	3,327	
9	9	24			42	18,000	5.28	30,000	8.79	33,600	9.85	1,123	2,326	3,327	
9	15	18			42	18,000	5.28	30,000	8.79	33,600	9.85	1,123	2,326	3,327	
12	15	15			42	18,000	5.28	30,000	8.79	33,600	9.85	1,123	2,326	3,327	

※ For our policy of continuous product improvement, specification, design and features are subject to change without prior notice.

Operation	Cooling														
	Combination of Indoor Unit (kBtu/h Class)						Total Capacity						Input(W)		
	UNIT-A	UNIT-B	UNIT-C	UNIT-D	UNIT-E	Total	Min		Rated		Max		Min	Rated	Max
						Btu/h	kW	Btu/h	kW	Btu/h	kW				
3 UNIT	7	18	18			43	18,000	5.28	30,000	8.79	33,600	9.85	1,123	2,326	3,327
	7	12	24			43	18,000	5.28	30,000	8.79	33,600	9.85	1,123	2,326	3,327
	5	15	24			44	18,000	5.28	30,000	8.79	33,600	9.85	1,123	2,326	3,327
	9	18	18			45	18,000	5.28	30,000						

# COMBINATION TABLE

## MU5R30

Operation	Cooling													Input(W)		
	Combination of Indoor Unit (kBtu/h Class)						Total Capacity									
	UNIT-A	UNIT-B	UNIT-C	UNIT-D	UNIT-E	Total	Min Btu/h	kW	Rated Btu/h	kW	Max Btu/h	kW	Min	Rated	Max	
5	5	5	5	5	5	25	15,000	4.40	25,000	7.33	30,000	8.79	841	1,517	2,300	
5	5	5	5	5	7	27	16,200	4.75	27,000	7.91	32,400	9.50	906	1,701	2,645	
5	5	5	5	5	9	29	17,400	5.10	29,000	8.50	34,800	10.20	993	1,897	3,026	
5	5	5	5	5	7	29	17,400	5.10	29,000	8.50	34,800	10.20	993	1,897	3,026	
5	5	5	5	5	9	31	18,000	5.28	30,000	8.79	36,000	10.55	1,037	2,000	3,260	
5	5	5	5	5	7	31	18,000	5.28	30,000	8.79	36,000	10.55	1,037	2,000	3,260	
5	5	5	5	5	12	32	18,000	5.28	30,000	8.79	36,000	10.55	1,037	2,000	3,260	
5	5	5	5	5	9	33	18,000	5.28	30,000	8.79	36,000	10.55	1,037	2,000	3,260	
5	5	5	5	5	7	33	18,000	5.28	30,000	8.79	36,000	10.55	1,037	2,000	3,260	
5	5	5	5	5	12	34	18,000	5.28	30,000	8.79	36,000	10.55	1,037	2,000	3,260	
5	5	5	5	5	15	35	18,000	5.28	30,000	8.79	36,000	10.55	1,037	2,000	3,260	
5	5	5	5	5	9	35	18,000	5.28	30,000	8.79	36,000	10.55	1,037	2,000	3,260	
5	5	5	5	5	7	35	18,000	5.28	30,000	8.79	36,000	10.55	1,037	2,000	3,260	
5	5	5	5	5	12	36	18,000	5.28	30,000	8.79	36,000	10.55	1,037	2,000	3,260	
5	5	5	5	5	9	37	18,000	5.28	30,000	8.79	36,000	10.55	1,037	2,000	3,260	
5	5	5	5	5	7	37	18,000	5.28	30,000	8.79	36,000	10.55	1,037	2,000	3,260	
5	5	5	5	5	18	38	18,000	5.28	30,000	8.79	36,000	10.55	1,037	2,000	3,260	
5	5	5	5	5	12	38	18,000	5.28	30,000	8.79	36,000	10.55	1,037	2,000	3,260	
5	5	5	5	5	15	39	18,000	5.28	30,000	8.79	36,000	10.55	1,037	2,000	3,260	
5	5	5	5	5	9	39	18,000	5.28	30,000	8.79	36,000	10.55	1,037	2,000	3,260	
5	5	5	5	5	7	39	18,000	5.28	30,000	8.79	36,000	10.55	1,037	2,000	3,260	
5	5	5	5	5	18	40	18,000	5.28	30,000	8.79	36,000	10.55	1,037	2,000	3,260	
5	5	5	5	5	12	40	18,000	5.28	30,000	8.79	36,000	10.55	1,037	2,000	3,260	
5	5	5	5	5	15	41	18,000	5.28	30,000	8.79	36,000	10.55	1,037	2,000	3,260	
5	5	5	5	5	9	41	18,000	5.28	30,000	8.79	36,000	10.55	1,037	2,000	3,260	
5	5	5	5	5	7	41	18,000	5.28	30,000	8.79	36,000	10.55	1,037	2,000	3,260	
5	5	5	5	5	18	42	18,000	5.28	30,000	8.79	36,000	10.55	1,037	2,000	3,260	
5	5	5	5	5	12	42	18,000	5.28	30,000	8.79	36,000	10.55	1,037	2,000	3,260	
5	5	5	5	5	15	42	18,000	5.28	30,000	8.79	36,000	10.55	1,037	2,000	3,260	
5	5	5	5	5	9	42	18,000	5.28	30,000	8.79	36,000	10.55	1,037	2,000	3,260	
5	5	5	5	5	7	42	18,000	5.28	30,000	8.79	36,000	10.55	1,037	2,000	3,260	
5	5	5	5	5	12	43	18,000	5.28	30,000	8.79	36,000	10.55	1,037	2,000	3,260	
5	5	5	5	5	15	43	18,000	5.28	30,000	8.79	36,000	10.55	1,037	2,000	3,260	
5	5	5	5	5	9	43	18,000	5.28	30,000	8.79	36,000	10.55	1,037	2,000	3,260	
5	5	5	5	5	7	43	18,000	5.28	30,000	8.79	36,000	10.55	1,037	2,000	3,260	
5	5	5	5	5	12	44	18,000	5.28	30,000	8.79	36,000	10.55	1,037	2,000	3,260	
5	5	5	5	5	15	44	18,000	5.28	30,000	8.79	36,000	10.55	1,037	2,000	3,260	
5	5	5	5	5	9	44	18,000	5.28	30,000	8.79	36,000	10.55	1,037	2,000	3,260	
5	5	5	5	5	7	44	18,000	5.28	30,000	8.79	36,000	10.55	1,037	2,000	3,260	
5	5	5	5	5	12	45	18,000	5.28	30,000	8.79	36,000	10.55	1,037	2,000	3,260	
5	5	5	5	5	15	45	18,000	5.28	30,000	8.79	36,000	10.55	1,037	2,000	3,260	
5	5	5	5	5	9	45	18,000	5.28	30,000	8.79	36,000	10.55	1,037	2,000	3,260	
5	5	5	5	5	7	45	18,000	5.28	30,000	8.79	36,000	10.55	1,037	2,000	3,260	
5	5	5	5	5	12	45	18,000	5.28	30,000	8.79	36,000	10.55	1,037	2,000	3,260	
5	5	5	5	5	15	45	18,000	5.28	30,000	8.79	36,000	10.55	1,037	2,000	3,260	
5	5	5	5	5	9	45	18,000	5.28	30,000	8.79	36,000	10.55	1,037	2,000	3,260	
5	5	5	5	5	7	45	18,000	5.28	30,000	8.79	36,000	10.55	1,037	2,000	3,260	
5	5	5	5	5	12	46	18,000	5.28	30,000	8.79	36,000	10.55	1,037	2,000	3,260	
5	5	5	5	5	15	46	18,000	5.28	30,000	8.79	36,000	10.55	1,037	2,000	3,260	
5	5	5	5	5	9	46	18,000	5.28	30,000	8.79	36,000	10.55	1,037	2,000	3,260	
5	5	5	5	5	7	46	18,000	5.28	30,000	8.79	36,000	10.55	1,037	2,000	3,260	
5	5	5	5	5	12	46	18,000	5.28	30,000	8.79	36,000	10.55	1,037	2,000	3,260	
5	5	5	5	5	15	47	18,000	5.28	30,000	8.79	36,000	10.55	1,037	2,000	3,260	
5	5	5	5	5	9	47	18,000	5.28	30,000	8.79	36,000	10.55	1,037	2,000	3,260	
5	5	5	5	5	7	47	18,000	5.28	30,000	8.79	36,000	10.55	1,037	2,000	3,260	
5	5	5	5	5	12	47	18,000	5.28	30,000	8.79	36,000	10.55	1,037	2,000	3,260	
5	5	5	5	5	15	47	18,000	5.28	30,000	8.79	36,000	10.55	1,037	2,000	3,260	
5	5	5	5	5	9	47	18,000	5.28	30,000	8.79	36,000	10.55	1,037	2,000	3,260	
5	5	5	5	5	7	47	18,000	5.28	30,000	8.79	36,000	10.55	1,037	2,000	3,260	
5	5	5	5	5	12	48	18,000	5.28	30,000	8.79	36,000	10.55	1,037	2,000	3,260	
5	5	5	5	5	15	48	18,000	5.28	30,000	8.79	36,000	10.55	1,037	2,000	3,260	
5	5	5	5	5	9	48	18,000	5.28	30,000	8.79	36,000	10.55	1,037	2,000	3,260	
5	5	5	5	5	7	48	18,000	5.28	30,000	8.79	36,000	10.55	1,037	2,000	3,260	
5	5	5	5	5	12	48	18,000	5.28	30,000	8.79	36,000	10.55	1,037	2,000	3,260	
5	5	5	5	5	15	48	18,000	5.28	30,000	8.79	36,000	10.55	1,037	2,000	3,260	
5	5	5	5	5	9	48	18,000	5.28	30,000	8.79	36,000	10.55	1,037	2,000	3,260	
5	5	5	5	5	7	48	18,000	5.28	30,000	8.79	36,000	10.55	1,037	2,000	3,260	
5	5	5	5	5	12	48	18,000	5.28	30,000	8.79	36,000	10.55	1,037	2,000	3,260	
5	5	5	5	5	15	48	18,000	5.28	30,000	8.79	36,000	10.55	1,037	2,000	3,260	
5	5	5	5	5	9	48	18,000	5.28	30,000	8.79	36,000	10.55	1,037	2,000	3,260	
5	5	5	5	5	7	48	18,000	5.28	30,000	8.79	36,000	10.55	1,037	2,000	3,260	

Operation	Heating													Input(W)		
	Combination of Indoor Unit (kBtu/h Class)						Total Capacity									
	UNIT-A	UNIT-B	UNIT-C	UNIT-D	UNIT-E	Total	Min Btu/h	kW	Rated Btu/h	kW	Max Btu/h	kW	Min	Rated	Max	
1 UNIT	5					5	5,000	1.47	5,500	1.61	6,325	1.85	610	610	714	
1 UNIT	7					7	5,500	1.61	6,480	1.90	7,275	2.11	610	636	825	
1 UNIT	9					9	6,480	1.90	10,800	3.17	12,420	3.64	610	826	1,077	
1 UNIT	12					12	7,920	2.32	13,200	3.87	15,180	4.45	583	1,021	1,338	
1 UNIT	15					15	9,900	2.90	16,500	4.84	18,975	5.56	744	1,279	1,744	
1 UNIT	18					18	11,880	3.48	19,800	5.80	22,770	6.67	909	1,577	2,133	
1 UNIT	24					24	15,240	4.47	25,400	7.44	26,670	7.82	1,192	2,077	2,538	
2 UNIT	5	5				10	7,200	2.11	12,000	3.52	14,400	4.22	451	773	1,081	
2 UNIT	5	7				12	8,640	2.53	14,400	4.22	17,280	5.06	541	940	1,337	
2 UNIT	5	9				14	10,080	2.95	16,800	4.92	20,160	5.91	656	1,112	1,571	
2 UNIT	5	12				17	12,240	3.59	20,400	5.98	24,480	7.17	796	1,289	1,844	
2 UNIT	5	15				19	13,680	4.01	22,800	6.68	27,360	8.02	892	1,471	2,094	
2 UNIT	5	18				21	15,120	4.43	25,200	7.03	28,800	8.44	940	1,657	2,352	
2 UNIT	5	24				24	18,720	5.39	30,240	8.86	33,120	9.71	1,112	1,960	2,568	
2 UNIT	7</															

# COMBINATION TABLE

## MU5R30

Operation	Heating														
	Combination of Indoor Unit (kBtu/h Class)					Total	Total Capacity					Input(W)			
	UNIT-A	UNIT-B	UNIT-C	UNIT-D	UNIT-E		Min	kW	Btu/h	kW	Btu/h	kW	Min	Rated	Max
3 UNIT	7	18	18			43	20,700	6.07	34,500	10.11	38,640	11.32	1,333	2,566	3,602
	7	12	24			43	20,700	6.07	34,500	10.11	38,640	11.32	1,333	2,566	3,602
	5	15	24			44	20,700	6.07	34,500	10.11	38,640	11.32	1,333	2,566	3,602
	9	18	18			45	20,700	6.07	34,500	10.11	38,640	11.32	1,333	2,566	3,602
	9	12	24			45	20,700	6.07	34,500	10.11	38,640	11.32	1,333	2,566	3,602
	12	15	18			45	20,700	6.07	34,500	10.11	38,640	11.32	1,333	2,566	3,602
	15	15	15			45	20,700	6.07	34,500	10.11	38,640	11.32	1,333	2,566	3,602
	7	15	24			46	20,700	6.07	34,500	10.11	38,640	11.32	1,333	2,566	3,602
	5	18	24			47	20,700	6.07	34,500	10.11	38,640	11.32	1,333	2,566	3,602
	9	15	24			48	20,700	6.07	34,500	10.11	38,640	11.32	1,333	2,566	3,602
	12	18	18			48	20,700	6.07	34,500	10.11	38,640	11.32	1,333	2,566	3,602
	12	12	24			48	20,700	6.07	34,500	10.11	38,640	11.32	1,333	2,566	3,602
	15	15	18			48	20,700	6.07	34,500	10.11	38,640	11.32	1,333	2,566	3,602
	5	5	5			20	14,400	4.22	24,000	7.03	28,800	8.44	840	1,480	2,100
	5	5	5		5	22	15,840	4.64	26,400	7.74	31,680	9.28	927	1,651	2,470
5	5	5		9	24	17,280	5.06	28,800	8.44	34,560	10.13	1,038	1,826	2,861	
5	5	7		7	24	17,280	5.06	28,800	8.44	34,560	10.13	1,038	1,826	2,861	
5	5	7		9	26	18,720	5.49	31,200	9.14	37,440	10.97	1,128	2,068	3,349	
5	5	7		7	26	18,720	5.49	31,200	9.14	37,440	10.97	1,128	2,068	3,349	
5	5	5		12	27	19,440	5.70	32,400	9.50	38,640	11.32	1,174	2,230	3,524	
5	5	5		9	28	20,160	5.91	33,600	9.85	38,640	11.32	1,220	2,356	3,524	
5	5	7		9	28	20,160	5.91	33,600	9.85	38,640	11.32	1,220	2,356	3,524	
5	5	7		7	28	20,160	5.91	33,600	9.85	38,640	11.32	1,220	2,356	3,524	
5	5	7		12	29	20,700	6.07	34,500	10.11	38,640	11.32	1,267	2,487	3,524	
5	5	5		15	30	20,700	6.07	34,500	10.11	38,640	11.32	1,267	2,487	3,524	
5	5	7		9	30	20,700	6.07	34,500	10.11	38,640	11.32	1,267	2,487	3,524	
5	5	7		9	30	20,700	6.07	34,500	10.11	38,640	11.32	1,267	2,487	3,524	
5	5	9		12	31	20,700	6.07	34,500	10.11	38,640	11.32	1,267	2,487	3,524	
5	5	7		12	31	20,700	6.07	34,500	10.11	38,640	11.32	1,267	2,487	3,524	
5	5	7		15	32	20,700	6.07	34,500	10.11	38,640	11.32	1,267	2,487	3,524	
5	5	9		9	32	20,700	6.07	34,500	10.11	38,640	11.32	1,267	2,487	3,524	
5	5	9		9	32	20,700	6.07	34,500	10.11	38,640	11.32	1,267	2,487	3,524	
5	5	5		18	33	20,700	6.07	34,500	10.11	38,640	11.32	1,267	2,487	3,524	
5	5	7		12	33	20,700	6.07	34,500	10.11	38,640	11.32	1,267	2,487	3,524	
5	5	9		15	34	20,700	6.07	34,500	10.11	38,640	11.32	1,267	2,487	3,524	
5	5	5		12	34	20,700	6.07	34,500	10.11	38,640	11.32	1,267	2,487	3,524	
5	5	7		15	34	20,700	6.07	34,500	10.11	38,640	11.32	1,267	2,487	3,524	
5	5	9		9	34	20,700	6.07	34,500	10.11	38,640	11.32	1,267	2,487	3,524	
5	5	7		18	35	20,700	6.07	34,500	10.11	38,640	11.32	1,267	2,487	3,524	
5	5	9		12	35	20,700	6.07	34,500	10.11	38,640	11.32	1,267	2,487	3,524	
5	5	9		12	35	20,700	6.07	34,500	10.11	38,640	11.32	1,267	2,487	3,524	
5	5	7		15	36	20,700	6.07	34,500	10.11	38,640	11.32	1,267	2,487	3,524	
5	5	9		12	36	20,700	6.07	34,500	10.11	38,640	11.32	1,267	2,487	3,524	
5	5	9		9	36	20,700	6.07	34,500	10.11	38,640	11.32	1,267	2,487	3,524	
5	5	9		9	36	20,700	6.07	34,500	10.11	38,640	11.32	1,267	2,487	3,524	
5	5	5		18	37	20,700	6.07	34,500	10.11	38,640	11.32	1,267	2,487	3,524	
5	5	5		12	37	20,700	6.07	34,500	10.11	38,640	11.32	1,267	2,487	3,524	
5	5	7		18	37	20,700	6.07	34,500	10.11	38,640	11.32	1,267	2,487	3,524	
5	5	9		12	37	20,700	6.07	34,500	10.11	38,640	11.32	1,267	2,487	3,524	
5	5	9		15	38	20,700	6.07	34,500	10.11	38,640	11.32	1,267	2,487	3,524	
5	5	7		12	38	20,700	6.07	34,500	10.11	38,640	11.32	1,267	2,487	3,524	
5	5	5		24	39	20,700	6.07	34,500	10.11	38,640	11.32	1,267	2,487	3,524	
5	5	7		18	39	20,700	6.07	34,500	10.11	38,640	11.32	1,267	2,487	3,524	
5	5	9		12	39	20,700	6.07	34,500	10.11	38,640	11.32	1,267	2,487	3,524	
5	5	7		18	39	20,700	6.07	34,500	10.11	38,640	11.32	1,267	2,487	3,524	
5	5	5		12	40	20,700	6.07	34,500	10.11	38,640	11.32	1,267	2,487	3,524	
5	5	9		15	40	20,700	6.07	34,500	10.11	38,640	11.32	1,267	2,487	3,524	
5	5	7		12	40	20,700	6.07	34,500	10.11	38,640	11.32	1,267	2,487	3,524	
5	5	9		12	40	20,700	6.07	34,500	10.11	38,640	11.32	1,267	2,487	3,524	
5	5	5		24	41	20,700	6.07	34,500	10.11	38,640	11.32	1,267	2,487	3,524	
5	5	7		18	41	20,700	6.07	34,500	10.11	38,640	11.32	1,267	2,487	3,524	
5	5	9		12	41	20,700	6.07	34,500	10.11	38,640	11.32	1,267	2,487	3,524	
5	5	7		12	41	20,700	6.07	34,500	10.11	38,640	11.32	1,267	2,487	3,524	
5	5	9		15	42	20,700	6.07	34,500	10.11	38,640	11.32	1,267	2,487	3,524	
5	5	9		9	42	20,700	6.07	34,500	10.11	38,640	11.32	1,267	2,487	3,524	
5	5	7		12	42	20,700	6.07	34,500	10.11	38,640	11.32	1,267	2,487	3,524	
5	5	9		12	42	20,700	6.07	34,500	10.11	38,640	11.32	1,267	2,487	3,524	
5	5	9		12	42	20,700	6.07	34,500	10.11	38,640	11.32	1,267	2,487	3,524	
5	5	7		18	43	20,700	6.07	34,500	10.11	38,640	11.32	1,267	2,487	3,524	
5	5	9		15	43	20,700	6.07	34,500	10.11	38,640	11.32	1,267	2,487	3,524	
5	5	7		12	43	20,700	6.07	34,500	10.11	38,640	11.32	1,267	2,487	3,524	
5	5	9		12	43	20,700	6.07	34,500	10.11	38,640	11.32	1,267	2,487	3,524	
5	5	5		18	44	20,700	6.07	34,500	10.11	38,640	11.32	1,267	2,487	3,524	
5	5	7		18	44	20,700	6.07	34,500	10.11	38,640	11.32	1,267	2,487	3,524	
5	5	9		12	44	20,700	6.07	34,500	10.11	38,640	11.32	1,267	2,487	3,524	
5	5	7		12	44	20,700	6.07	34,500	10.11	38,640	11.32	1,267	2,487	3,524	
5	5	9		15	45	20,700	6.07	34,500	10.11	38,640	11.32	1,267	2,487	3,524	
5	5	5		24	45	20,700	6.07	34,500	10.11	38,640	11.32	1,267	2,487	3,524	
5	5	7		18	45	20,700	6.07	34,500	10.11	38,640	11.32	1,267	2,487	3,524	
5	5	9		12	45	20,700	6.07	34,500	10.11	38,640	11.32	1,267	2,487	3,524	
5	5	7		12	45	20,700	6.07	34,500	10.11	38,640	11.32	1,267	2,487	3,524	
5	5	9		15	45	20,700	6.07	34,500	10.11	38,640	11.32	1,267	2,487	3,524	
5	5	7		18	45	20,700	6.07	34,500	10.11	38,640	11.32	1,267	2,487	3,524	
5	5	9		12	45	20,700	6.07	34,500	10.11	38,640	11.32	1,267	2,487	3,524	
5	5	7		18	45	20,700	6.07	34,500	10.11	38,640	11.32	1,267	2,487	3,524	
5	5	9		12	45	20,700	6.07	34,500	10.11	38,640	11.32	1,267	2,487	3,524	
5	5	7		24	46	20,700	6.07	34,500	10.11	38,640	11.32	1,267	2,487	3,524	
5	5	9		15	46	20,700	6.07	34,500	10.11	38,640	11.32	1,267	2,487	3,524	
5	5	7		12	46	20,700	6.07	34,500	10.11	38,640	11.32	1,267	2,487	3,524	
5	5	9		15	46	20,700	6.07	34,500	10.11	38,640	11.32	1,267	2,487	3,524	
5	5	7		12	46	20,7									

# R410A MULTI SPLIT



R410A MULTI SPLIT

## OUTDOOR UNITS



RESIDENTIAL

MU5M40

(Unit : mm)



LG participates in the ECP programme for EUROVENT AC program.  
Check ongoing validity of certification  
: www.eurovent-certification.com

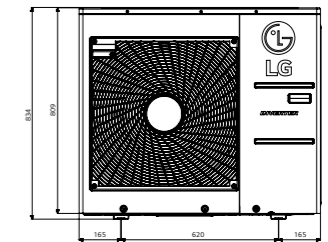
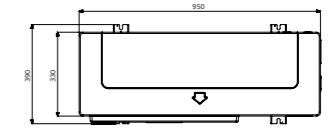

OUTDOOR				MU5M40.U44	
Compressor	Type			R-Scroll	
Capacity*	Cooling	Min / Nom / Max	kW	1.8 / 11.2 / 14.7	
	Heating	Min / Nom / Max	kW	2.0 / 12.5 / 15.5	
Low Temperature Capacity	Heating -7°C	Max	kW	11.0	
Power Input*	Cooling	Min / Nom / Max	kW	0.8 / 2.8 / 5.0	
	Heating	Min / Nom / Max	kW	0.8 / 2.9 / 5.2	
EER				4.0	
COP				4.3	
SEER				7.1	
SCOP				4.0	
Pdesign (@-10°C)				8.8	
Season Energy Label	Cooling / Heating (A+++ to E Scale)			A++ / A+	
Season Energy Consumtuin	Cooling / Heating			kWh	552 / 3,080
Airflow Rate			Nom	m³/min	70
Sound Pressure	Cooling	Nom		dBA	53
	Heating	Nom		dBA	55
Sound Power	Cooling	Max		dBA	67
Dimensions	W x H x D			mm	950 x 834 x 330
Net Weight				kg	72
Refrigerant	Type			R410A	
	Charge			kg	3.5
	Additional Charge			g/m	20
	GWP				2087.5
Operation Range (Outdoor)	Cooling	Min / Max	°C DB	-10 - 48	
	Heating	Min / Max	°C WB	-18 - 18	
Power Supply				Ø / V / Hz	1 / 220-240 / 50
Power Supply Cable				No. x mm²	3C x 4.0
Transmission Cable	ODU-BD			No. x mm²	4C x 0.75
	BD-IDU			No. x mm²	4C x 0.75
Circuit Breaker				A	30
Piping Length Total				m	85
Piping Length per Branch			Max	m	25
Piping Elevation Difference	IDU - ODU	Max		m	15
	IDU - IDU	Max		m	7.5
Piping Connection	Liquid			mm (inch) x No.	Ø6.35 (1/4) x 5
	Gas			mm (inch) x No.	Ø9.52 (3/8) x 5

※ For our policy of continuous product improvement, specification, design and features are subject to change without prior notice.

Note : 1. Capacities are based on the following conditions:

Cooling : - Indoor Temperature 27°C (80.6°F) DB / 19°C (66.2°F) WB - Outdoor Temperature 35°C (95°F) DB / 24°C (75.2°F) WB

Heating : - Indoor Temperature 20°C (68°F) DB / 15°C (59°F) WB - Outdoor Temperature 7°C (44.6°F) DB / 6°C (42.8°F) WB

Piping Length - Interconnecting Piping Length 7.5m - Level Difference of Zero.

2. \* : See page "Combination Table".

3. Due to our policy of innovation some specifications may be changed without notification.

4. At least two indoor units should be connected.

5. Minimum combination capacity rate should be more than 40%.

6. This product contains fluorinated greenhouse gases (R410A)

# OUTDOOR UNITS



FM40AH  
FM48AH  
FM56AH



LG participates in the ECP programme for EUROVENT AC program.  
Check ongoing validity of certification  
: www.eurovent-certification.com

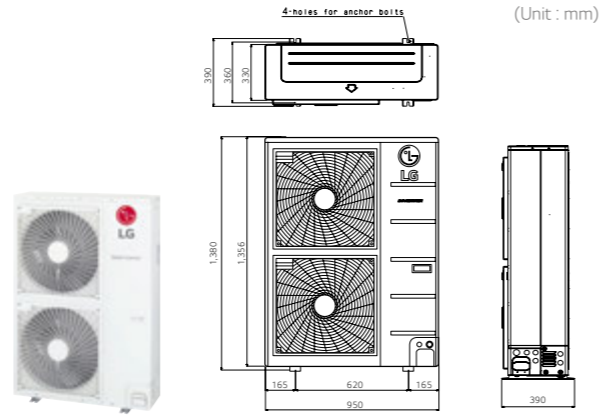

FM41AH  
FM49AH  
FM57AH

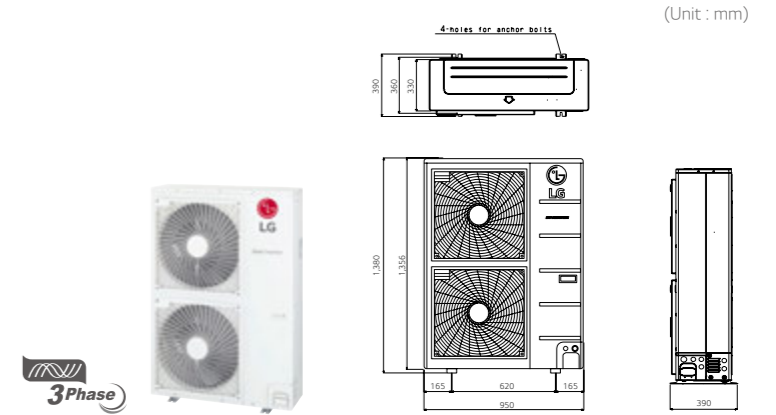

OUTDOOR				FM40AH.U34	FM48AH.U34	FM56AH.U34		
Compressor	Type			R-Scroll	R-Scroll	R-Scroll		
Capacity*	Cooling	Min / Nom / Max	kW	2.4 / 12.3 / 15.4	2.8 / 14.0 / 17.0	2.8 / 15.5 / 18.5		
	Heating	Min / Nom / Max	kW	2.6 / 13.5 / 16.2	3.2 / 16.0 / 17.3	3.2 / 17.4 / 18.8		
Low Temperature Capacity	Heating -7°C	Max	kW	12.0	13.6	14.8		
Power Input*	Cooling	Min / Nom / Max	kW	1.0 / 2.6 / 4.4	1.0 / 3.3 / 5.4	1.0 / 4.0 / 5.9		
	Heating	Min / Nom / Max	kW	1.5 / 2.9 / 4.8	1.5 / 3.8 / 5.8	1.5 / 4.4 / 6.5		
EER				4.8	4.2	3.9		
COP				4.7	4.2	4.0		
SEER				7.3	7.1	6.7		
SCOP				4.2	4.2	4.2		
Pdesign (@-10°C)			kW	11.2	11.2	11.2		
Season Energy Label	Cooling / Heating (A+++ to E Scale)			A++ / A+	A++ / A+	A++ / A+		
Season Energy Consumptuin	Cooling / Heating			kWh	590 / 3,733	690 / 3,733	810 / 3,733	
Airflow Rate		Nom	m³/min	120	120	120		
Sound Pressure	Cooling	Nom	dBA	53	53	53		
	Heating	Nom	dBA	55	55	55		
Sound Power	Cooling	Max	dBA	66	67	68		
Dimensions	W x H x D			mm	950 x 1,380 x 330	950 x 1,380 x 330	950 x 1,380 x 330	
Net Weight				kg	88	88	88	
Refrigerant	Type				R410A	R410A	R410A	
	Charge				kg	4.2	4.2	4.2
	Additional Charge				g/m	20	20	20
	GWP					2087.5	2087.5	2087.5
	t-CO <sub>2</sub> eq					9.2	9.2	9.2
Operation Range (Outdoor)	Cooling	Min / Max	°C DB	-10 - 48	-10 - 48	-10 - 48		
	Heating	Min / Max	°C WB	-18 - 18	-18 - 18	-18 - 18		
Power Supply	Ø / V / Hz			1 / 220-240 / 50	1 / 220-240 / 50	1 / 220-240 / 50		
Power Supply Cable	No. x mm²			3C x 4.0	3C x 4.0	3C x 4.0		
Transmission Cable	ODU-BD	No. x mm²			4C x 1.25	4C x 1.25	4C x 1.25	
	BD-IDU	No. x mm²			4C x 0.75	4C x 0.75	4C x 0.75	
Circuit Breaker	A			40	40	40		
Piping Length Total	m			125	135	145		
Piping Length per Branch	Max	m		15	15	15		
Piping Elevation	IDU - ODU	Max	m	30	30	30		
Piping Elevation Difference	IDU - IDU	Max	m	15	15	15		
Piping Connection	Liquid	mm (inch) x No.		Ø9.52 (3/8)	Ø9.52 (3/8)	Ø9.52 (3/8)		
	Gas	mm (inch) x No.		Ø19.05 (3/4)	Ø19.05 (3/4)	Ø19.05 (3/4)		

※ For our policy of continuous product improvement, specification, design and features are subject to change without prior notice.

Note : 1. Capacities are based on the following conditions:

Cooling : - Indoor Temperature 27°C (80.6°F) DB / 19°C (66.2°F) WB - Outdoor Temperature 35°C (95°F) DB / 24°C (75.2°F) WB

Heating : - Indoor Temperature 20°C (68°F) DB / 15°C (59°F) WB - Outdoor Temperature 7°C (44.6°F) DB / 6°C (42.8°F) WB

Piping Length - Interconnecting Piping Length 7.5m - Level Difference of Zero.

2. \* : See page "Combination Table".

3. Due to our policy of innovation some specifications may be changed without notification.

4. At least two indoor units should be connected.

5. Minimum combination capacity rate should be more than 40%.

6. This product contains fluorinated greenhouse gases (R410A)

OUTDOOR				FM41AH.U34	FM49AH.U34	FM57AH.U34		
Compressor	Type			R-Scroll	R-Scroll	R-Scroll		
Capacity*	Cooling	Min / Nom / Max	kW	2.8 / 12.3 / 14.7	2.8 / 14.0 / 17.0	2.8 / 15.5 / 18.5		
	Heating	Min / Nom / Max	kW	3.2 / 13.5 / 15.2	3.2 / 16.0 / 17.3	3.2 / 17.4 / 18.8		
Low Temperature Capacity	Heating -7°C	Max	kW	12.0	13.6	14.8		
Power Input*	Cooling	Min / Nom / Max	kW	1.0 / 2.6 / 4.4	1.0 / 3.3 / 5.4	1.0 / 4.0 / 5.9		
	Heating	Min / Nom / Max	kW	1.5 / 2.9 / 4.8	1.5 / 3.8 / 5.8	1.5 / 4.4 / 6.5		
EER				4.8	4.2	3.9		
COP				4.7	4.2	4.0		
SEER				7.3	7.1	6.7		
SCOP				4.2	4.2	4.2		
Pdesign (@-10°C)			kW	11.2	11.2	11.2		
Season Energy Label	Cooling / Heating (A+++ to E Scale)			A++ / A+	A++ / A+	A++ / A+		
Season Energy Consumptuin	Cooling / Heating			kWh	590 / 3,733	690 / 3,733	810 / 3,733	
Airflow Rate		Nom	m³/min	120	120	120		
Sound Pressure	Cooling	Nom	dBA	53	53	53		
	Heating	Nom	dBA	55	55	55		
Sound Power	Cooling	Max	dBA	66	67	68		
Dimensions	W x H x D			mm	950 x 1,380 x 330	950 x 1,380 x 330	950 x 1,380 x 330	
Net Weight				kg	88	88	88	
Refrigerant	Type				R410A	R410A	R410A	
	Charge				kg	4.2	4.2	4.2
	Additional Charge				g/m	20	20	20
	GWP					2087.5	2087.5	2087.5
	t-CO <sub>2</sub> eq					9.2	9.2	9.2
Operation Range (Outdoor)	Cooling	Min / Max	°C DB	-10 - 48	-10 - 48	-10 - 48		
	Heating	Min / Max	°C WB	-18 - 18	-18 - 18	-18 - 18		
Power Supply	Ø / V / Hz			3 / 380-415 / 50	3 / 380-415 / 50	3 / 380-415 / 50		
Power Supply Cable	No. x mm²			5C x 2.5	5C x 2.5	5C x 2.5		
Transmission Cable	ODU-BD	No. x mm²			4C x 1.25	4C x 1.25	4C x 1.25	
	BD-IDU	No. x mm²			4C x 0.75	4C x 0.75	4C x 0.75	
Circuit Breaker	A			20	20	20		
Piping Length Total	m			125	135	145		
Piping Length per Branch	Max	m		15	15	15		
Piping Elevation	IDU - ODU	Max	m	30	30	30		
Piping Elevation Difference	IDU - IDU	Max	m	15	15	15		
Piping Connection	Liquid	mm (inch) x No.		Ø9.52 (3/8)	Ø9.52 (3/8)	Ø9.52 (3/8)		
	Gas	mm (inch) x No.		Ø19.05 (3/4)	Ø19.05 (3/4)	Ø19.05 (3/4)		

※ For our policy of continuous product improvement, specification, design and features are subject to change without prior notice.

Note : 1. Capacities are based on the following conditions:

Cooling : - Indoor Temperature 27°C (80.6°F) DB / 19°C (66.2°F) WB - Outdoor Temperature 35°C (95°F) DB / 24°C (75.2°F) WB

Heating : - Indoor Temperature 20°C (68°F) DB / 15°C (59°F) WB - Outdoor Temperature 7°C (44.6°F) DB / 6°C (42.8°F) WB

Piping Length - Interconnecting Piping Length 7.5m - Level Difference of Zero.

2. \* : See page "Combination Table".

3. Due to our policy of innovation some specifications may be changed without notification.

4. At least two indoor units should be connected.

5. Minimum combination capacity rate should be more than 40%.

6. This product contains fluorinated greenhouse gases (R410A)



# CEILING & FLOOR CONVERTIBLE

## Flexible Installation

The ceiling and floor models can be installed either on the ceiling or on the floor. This saves space when installed in the shops or offices.

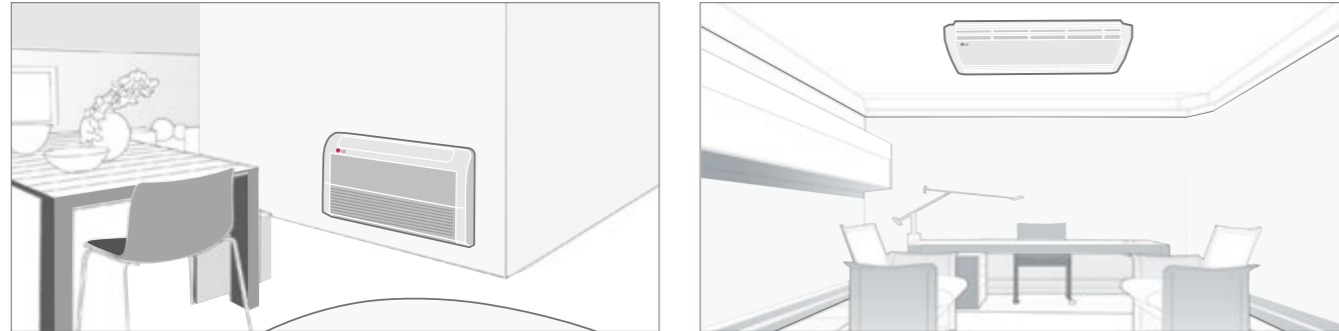

\* Ceiling & Floor: CV09 NE2 / CV12 NE2

## Airflow Direction Control

Vertical airflow direction can be adjusted using remote controller, and horizontal airflow direction can be adjusted manually.

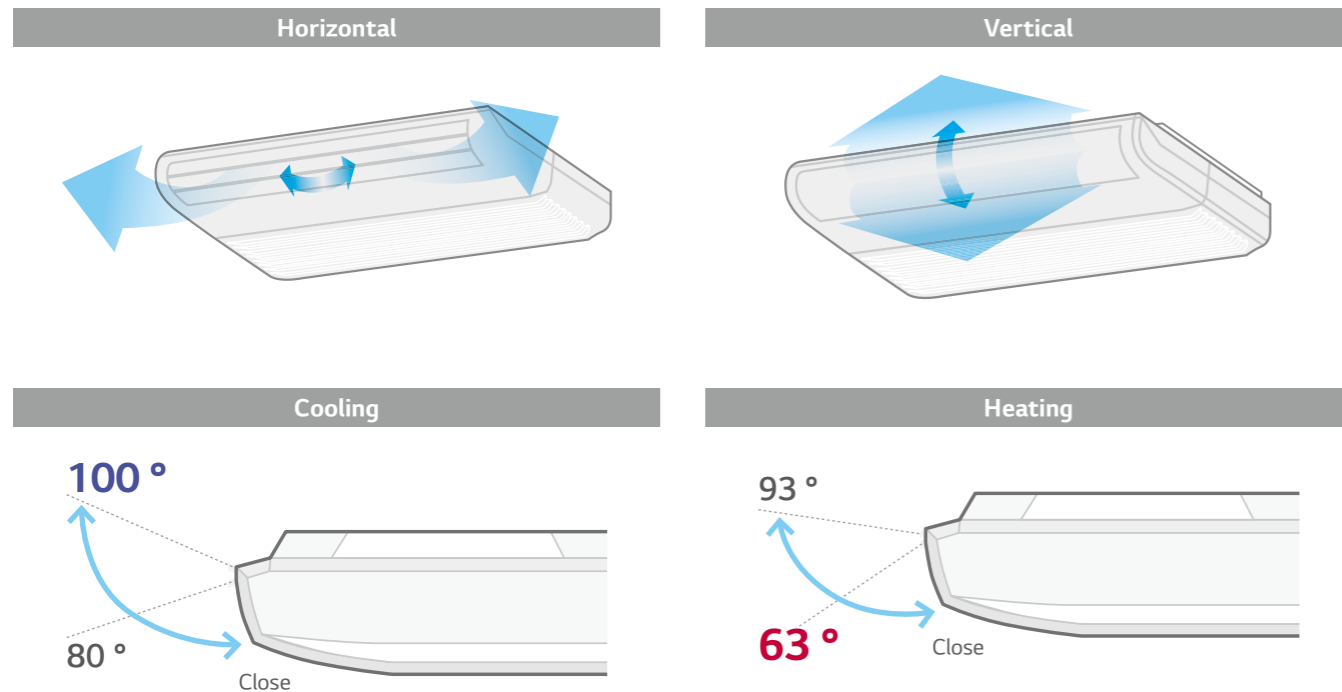

CAPACITY (kW)		2.6	3.5	5.3	7.0
Ceiling & Floor Convertible unit		CV09.NE2	CV12.NE2	-	-

## Ceiling & Floor Convertible unit

INDOOR				CV09.NE2	CV12.NE2
Capacity	Cooling / Heating	Nom	kW	2.6 / 2.9	3.5 / 3.9
Power Input		Nom	W	30	40
Running Current		Nom	A	0.4	0.4
Power Supply			Ø / V / Hz	1 / 220-240 / 50	1 / 220-240 / 50
Air Flow Rate		H / M / L	m³/min	7.6 / 6.9 / 6.2	9.2 / 7.6 / 6.6
Sound Pressure	Cooling	H / M / L	dBA	38 / 35 / 32	40 / 36 / 31
Sound Power	Cooling	Max	dBA	52	56
Dehumidification Rate			l/h	1.2	1.2
Dimensions	Body	W x H x D	mm	900 x 490 x 200	900 x 490 x 200
Net Weight	Body		kg	13.7	13.7
Piping	Liquid		mm (inch)	Ø6.35 (1/4)	Ø6.35 (1/4)
Connection	Gas		mm (inch)	Ø9.52 (3/8)	Ø9.52 (3/8)

※ For our policy of continuous product improvement, specification, design and features are subject to change without prior notice.

Note: 1. Capacities are based on the following conditions:

Cooling: - Indoor Temperature 27°C (80.6°F) DB / 19°C (66.2°F) WB - Outdoor Temperature 35°C (95°F) DB / 24°C (75.2°F) WB

Heating: - Indoor Temperature 20°C (68°F) DB / 15°C (59°F) WB - Outdoor Temperature 7°C (44.6°F) DB / 6°C (42.8°F) WB

Piping Length - Interconnecting Piping Length 7.5m - Level Difference of Zero

2. Definition of Power Input Nominal conditions - Performance tested under EN14511

3. Due to our policy of innovation some specifications may be changed without notification

4. This product contains fluorinated greenhouse gases (R410A)

\* CV09, CV12, CV18, CV24 are compatible between SCAC and MULTI.

# R410A MULTI SPLIT CONSOLE

## Optimised Air Flow for Cooling & Heating

During the cooling operation, the vane adjusts upwards to direct the air flow towards the ceiling. When heating, the vane directs the warm air downwards to balance the room temperature especially for floor.

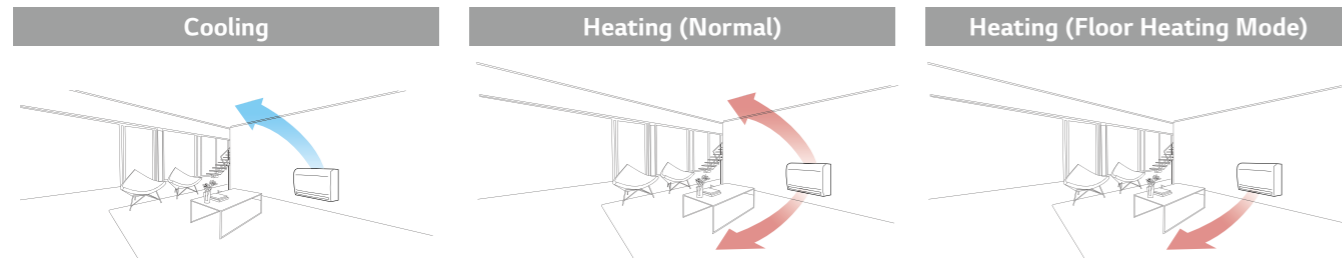

## Quick Floor Heating

Console air conditioners offer a fast and powerful performance. Using the floor heating mode, console air conditioners provide faster floor heating and help to reach the desired temperature quickly.

	Company A	Electric Heater	LG	LG Floor Heating Mode
27°C				
Vertical				
15°C				
Horizontal				
Lead Time for Heating (13°C - 21°C)	12 minutes 30 seconds	50 minutes	9 minutes 30 seconds	8 minutes 40 seconds

(Test Condition: Target Temp 23°C, Indoor Room: 13°C-, Outdoor Room: 7°C)

## 5-Step Vane Control

There are 5 different stages to control air flow direction.

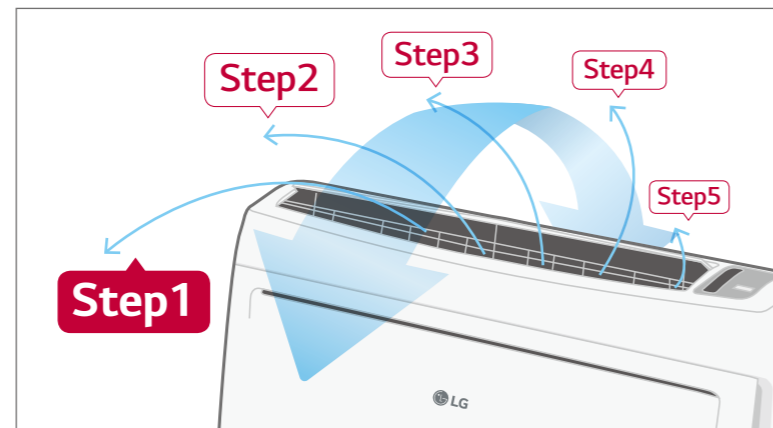

CAPACITY (KW)		2.6	3.5	5.3
Console		CQ09.NA0	CQ12.NA0	CQ18.NA0

## Console

INDOOR				CQ09.NA0
Capacity	Cooling / Heating	Nom	kW	2.6 / 2.9
Power Input		Nom	W	20
Running Current		Nom	A	0.6
Power Supply			Ø / V / Hz	1 / 220-240 / 50
Air Flow Rate		H / M / L	m³/min	8.5 / 6.7 / 5.0
Sound Pressure	Cooling	H / M / L	dBA	38 / 32 / 27
Sound Power	Cooling	Max	dBA	53
Dehumidification Rate			l/h	1.2
Dimensions	Body	W x H x D	mm	700 x 600 x 210
Net Weight	Body		kg	14.0
Piping	Liquid		mm (inch)	Ø6.35 (1/4)
Connection	Gas		mm (inch)	Ø9.52 (3/8)

\* CQ09, CQ12, CQ18 are compatible between SCAC and MULTI.

INDOOR				CQ12.NA0	CQ18.NA0
Capacity	Cooling / Heating	Nom	kW	3.5 / 3.9	5.3 / 5.8
Power Input		Nom	W	20	40
Running Current		Nom	A	0.6	0.7
Power Supply			Ø / V / Hz	1 / 220-240 / 50	1 / 220-240 / 50
Air Flow Rate		H / M / L	m³/min	9.0 / 6.9 / 5.2	10.1 / 8.6 / 7.2
Sound Pressure	Cooling	H / M / L	dBA	39 / 32 / 27	44 / 39 / 35
Sound Power	Cooling	Max	dBA	56	60
Dehumidification Rate			l/h	1.4	2.3
Dimensions	Body	W x H x D	mm	700 x 600 x 210	700 x 600 x 210
Net Weight	Body		kg	14.0	14.0
Piping	Liquid		mm (inch)	Ø6.35 (1/4)	Ø6.35 (1/4)
Connection	Gas		mm (inch)	Ø9.52 (3/8)	Ø12.7 (1/2)

※ For our policy of continuous product improvement, specification, design and features are subject to change without prior notice.

Note : 1. Capacities are based on the following conditions :

Cooling : - Indoor Temperature 27°C (80.6°F) DB / 19°C (66.2°F) WB - Outdoor Temperature 35°C (95°F) DB / 24°C (75.2°F) WB  
 Heating : - Indoor Temperature 20°C (68°F) DB / 15°C (59°F) WB - Outdoor Temperature 7°C (44.6°F) DB / 6°C (42.8°F) WB

- Piping Length - Interconnecting Piping Length 7.5m - Level Difference of Zero
- Definition of Power Input Nominal conditions - Performance tested under EN14511
- Due to our policy of innovation some specifications may be changed without notification
- This product contains fluorinated greenhouse gases (R410A)

# LG Wi-Fi MODEM

Control LG air conditioners via using the internet devices as Android or iOS bases smartphones

## PWFMDD200

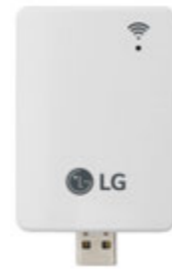

### Features

- Access LG air conditioner anytime and from anywhere with Wi-Fi equipped device
- LG's exclusive Home Appliances control app(SmartThinQ) is available
- Simple operation for various functions
  - On/Off
  - Fan Speed
  - Energy Monitoring <sup>1)</sup>
  - Operation Mode
  - Vane Control <sup>2)</sup>
  - Filter Management
  - Current/Set Temperature
  - Reservation (Sleep, Weekly On/Off)
  - Error check

MODEL NAME	PWFMDD200
Size (W x H x D, mm)	48 x 68 x 14
Interfaceable Products	Multi Indoor unit <sup>3)</sup>
Connection Type	Indoor unit 1:1
Communication Frequency	2.4 GHz
Wireless Standards	IEEE 802.11b/g/n
Mobile Application	LG Smart ThinQ (Android v4.1(Jellybean) or higher, iPhone iOS 9.0 or higher)
Optional Extension Cable	PWYREW000 (10m extension)

\* Functionality may be different according to each IDU model  
 \* User interface of application shall be revised for its design and contents improvement  
 \* Application is optimized for smartphone use, so it may not be well functioning with tablet devices  
 1) LG Centralized controller and PDI installation is required for this function  
 2) Vane Control may not be possible according to the type of Indoor unit  
 3) For the compatibility with Indoor unit, please contact regional office



### Overview

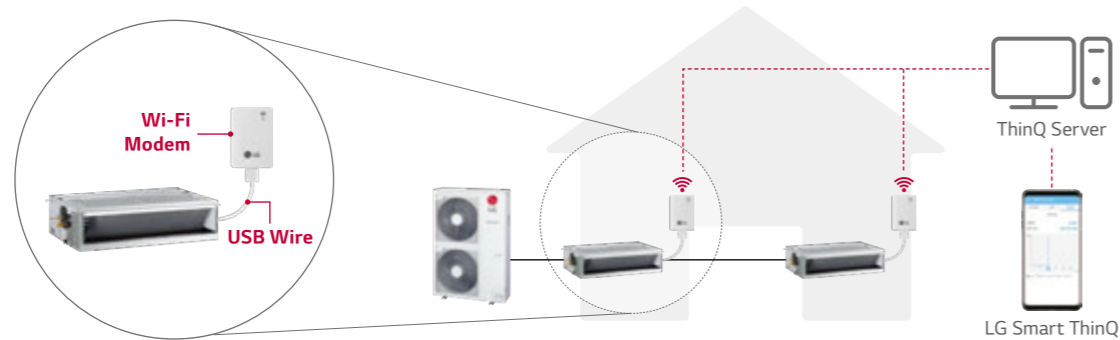

\* Search "LG Smart ThinQ" on Google market or Appstore then download the app.  
 \* Internet service with Wi-Fi connection has to be available

# ACCESSORIES

## Standard Wired Remote Controller

### Standard III



PREMTB100 PREMTBB10

### Standard II



PREMTB001 PREMTBB01

Model Name	PREMTB100 PREMTBB10	PREMTB001 PREMTBB01
Operation Mode	On/Off, Fan Speed Control, Temperature Setting	
Mode Change	Cooling / Heating / Auto / Dehumidification / Fan	
Auto Swing / Vane Control	•	•
Reservation	Simple / Sleep / On, Off / Weekly / Holiday	
Time Display	•	•
Electrical Failure Compensation	•	•
Child Lock	•	•
Operation Status LED	•	•
Indoor Temperature Display	•	•
Wireless Remote Controller Receiver	-	•
Size (W x H x D, mm)	120 x 120 x 16	120 x 121 x 16
Backlight	•	•

\* Refer to each model PDB for applicable models.

## Remote Controller



PQWRHQ0FDB

## PI 485

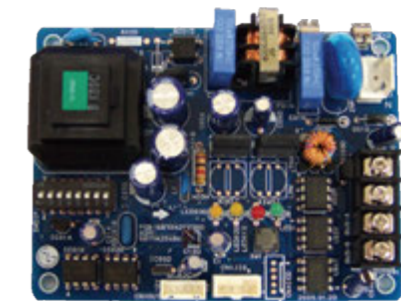

PMNFP14A1

Power : Single phase AC 220V 50/60Hz  
 Max. no of the indoor units that can be connected: 64 UNITS  
 Model applied : RAC / Multi / Single / Thermo V

\* Refer to each product PDB for applicable models

## Dry Contact

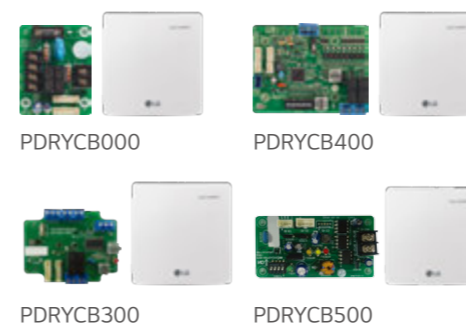

\* Refer to each product PDB for applicable models

MODEL	PDRYCB000	PDRYCB400	PDRYCB300	PDRYCB500
Contact Point	1 Control Point	2 Control Point	8 Control Point	Modbus RTU
Power Input	AC 220V from outside power source	DC 5V & 12V from indoor unit PCB	DC 5V & 12V from indoor unit PCB	DC 5V & 12 V from indoor unit PDB
Voltage / Non Voltage Input		•	•	
On / Off Control	•	•	•	•
Lock / Unlock	•	•	•	
Fan Speed Setting		•	•	•
Thermo Off		•	•	
Energy Saving		•		
Temperature Setting		•	•	•
Error Monitoring	•	•	•	•
Operation Monitoring	•	•	•	•

# ACCESSORIES

## Distributor Box

### PMBD3620, PMBD3630, PMBD3640

Easy installation using the range of Distributor Boxes.

For	2 Indoors	3 Indoors	4 Indoors
Distributor	 PMBD3620	 PMBD3630	 PMBD3640

Various distributors can make much easier installation for any sites

### Features

- Distribution of refrigerant to various indoor units.
- 3 models (2, 3, 4 Indoor Units)
- EEV included
- Controlling PCB inside the unit
- Internally insulated (Prevents any chances of drainage)
- Flare joints for easy and clean installation
- Compact design (Low height)
- Flexible installation

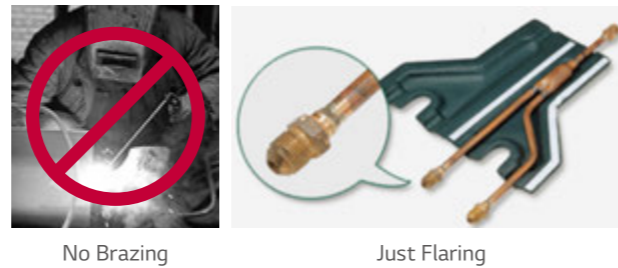

### Specification

		PMBD3620	PMBD3630	PMBD3640
Connectable Indoor Units	Number of Indoor Units	1 - 2	1 - 3	1 - 4
	Capacity	5k / 7k / 9k / 12k / 18k / 24k	5k / 7k / 9k / 12k / 18k / 24k	5k / 7k / 9k / 12k / 18k / 24k
Power Source	Ø / V / Hz	1 / 220-240 / 50	1 / 200-240 / 50	1 / 200-240 / 50
Power Consumption	W	10	10	10
Running Current	A	0.05	0.05	0.05
Dimensions	W x H x D	mm (inch) 302 x 143 x 252 (11.9 x 5.6 x 9.9)	mm (inch) 302 x 143 x 252 (11.9 x 5.6 x 9.9)	mm (inch) 302 x 143 x 252 (11.9 x 5.6 x 9.9)
Net Weight	kg/lb	4.8 / 10.6	4.9 / 10.8	5 / 11
Piping Connection (To Outdoor Unit)	Liquid	mm (inch) Ø9.52 (3/8)	mm (inch) Ø9.52 (3/8)	mm (inch) Ø9.52(3/8)
	Gas	mm (inch) Ø19.05 (3/4)	mm (inch) Ø19.05 (3/4)	mm (inch) Ø19.05(3/4)
Piping Connection (To Indoor Unit)	Liquid	mm (inch) Ø6.35 (1/4) x 2EA	mm (inch) Ø6.35 (1/4) x 3EA	mm (inch) Ø6.35 (1/4) x 4EA
	Gas	mm (inch) Ø9.52 (3/8) x 2EA	mm (inch) Ø9.52 (3/8) x 3EA	mm (inch) Ø9.52 (3/8) x 4EA
Accessories	Hanger (Bracket)	EA 4	EA 4	EA 4
	Screw	EA 8	EA 8	EA 8
	Manual	EA 1	EA 1	EA 1

※ For our policy of continuous product improvement, specification, design and features are subject to change without prior notice.  
 Note : 1. The piping connection must be suit the piping sizes of the indoor unit which will be connected. (If need, use the connector which is included in the indoor unit)  
 2. The BD should be installed inside the building.

## Y Branch and Branch Kit

### PMBL5620 (2 units) / PMBL1203F0 (3 units)





### Features

- Y Branch and Branch kit make Multi FDX installation much easier.
- Y Branch and Branch kit for both gas and liquid are provided.
- Insulation material is also provided for covering the branches.

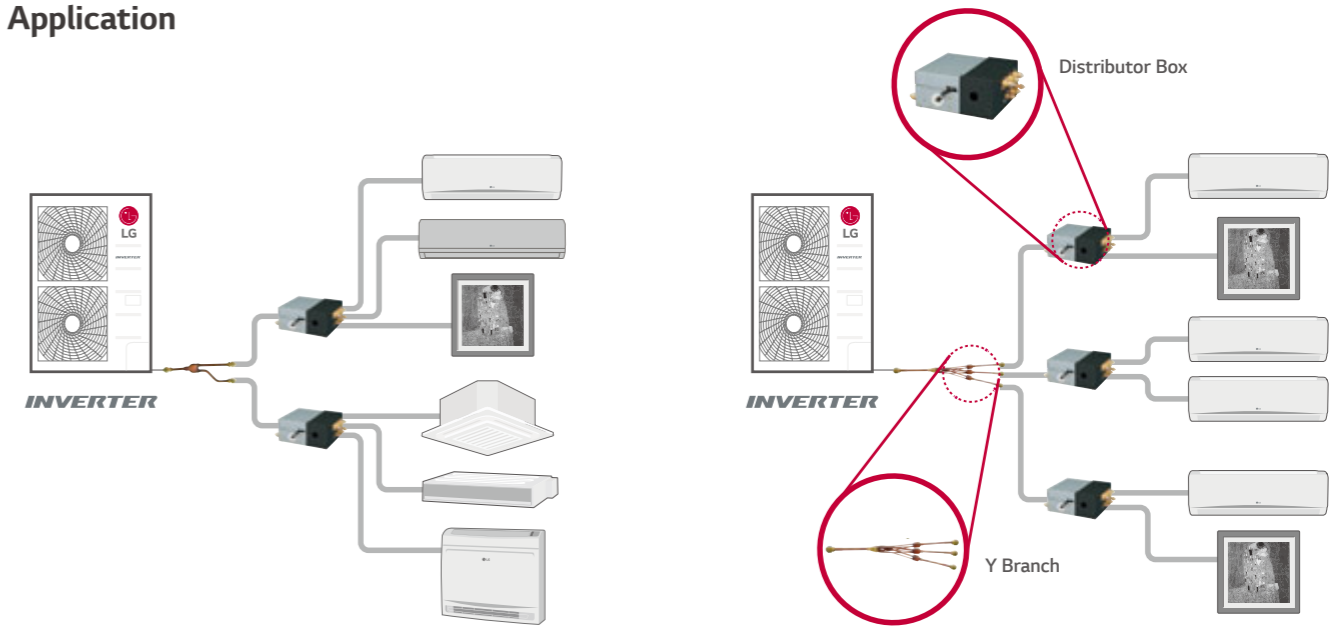
### Application

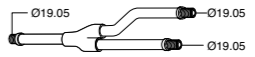
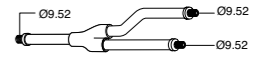

### Accessory Model Name

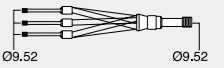
MODEL NAME	NO. OF BRANCH DISTRIBUTION UNITS	APPLICABLE MODEL	SPECIFICATION	
			GAS	LIQUID
PMBL5620	2 Units	1Ø, 3Ø		
PMBL1203F0	3 Units	1Ø, 3Ø		

(Unit : mm)



# COMMERCIAL

SINGLE SPLIT



SINGLE SPLIT  
**LINE-UP**

**STANDARD INVERTER**

STANDARD INVERTER (R32)												STANDARD INVERTER (R410A)				
kBTu/h	Type kW	Ceiling Mounted Cassette	Ceiling Concealed Duct		Ceiling & Floor / Ceiling Suspended	ODU		Ceiling Concealed Duct (High Static)	Ceiling & Floor / Ceiling Suspended	Console / Wall Mounted / Floor Standing	ODU					
			Mid/High Static	Low Static		1Ø	3Ø				1Ø	3Ø				
9	2.5	 CT09R.NR0		 CL09R.N20		 UU09WR.U00		 CV09.NE2	 CQ09.NA0	 UU09W.U00						
12	3.5	 CT12R.NR0		 CL12R.N20		 UU12WR.U00		 CV12.NE2	 CQ12.NA0	 UU12W.U00						
18	5.0	 CT18R.NQ0	 CM18R.N10	 CL18R.N20	 UV18R.N10	 UU18WR.U20			 CQ18.NA0	 UU18W.UE4						
24	7.1	 CT24R.NP0	 CM24R.N10	 CL24R.N30	 UV24R.N10	 UU24WR.U40										
30	8.0	 UT30R.NP0*	 UM30R.N10*		 UV30R.N10*	 UU30WR.U40*			 UJ30.NV2	 UU30W.U44						
36	10.0	 UT36R.NM0	 UM36R.N20*		 UV36R.N20	 UU36WR.U30	 UU37WR.U30		 UJ36.NV3	 UU36W.U02	 UU37W.U02					
42	12.5	 UT42R.NM0	 UM42R.N20		 UV42R.N20	 UU42WR.U30	 UU43WR.U30									
48	14.0	 UT48R.NM0	 UM48R.N30		 UV48R.N20	 UU48WR.U30	 UU49WR.U30		 UP48.NT2	 UU48W.U32	 UU49W.U32					
60	15.0	 UT60R.NM0	 UM60R.N30		 UV60R.N20	 UU60WR.U30	 UU61WR.U30									
70	20.0							 UB70.N94			 UU70W.U34					
85	25.0							 UB85.N94			 UU85W.U74					

\* Available from April 2019.  
※ For our policy of continuous product improvement, specification, design and features are subject to change without prior notice.

SINGLE SPLIT  
**LINE-UP**

**COMPACT INVERTER**

COMPACT INVERTER (R32)							
kBTu/h	Type kW	Ceiling Mounted Cassette	Ceiling Concealed Duct		Ceiling & Floor / Ceiling Suspended	ODU	
			Mid / High Static	Low Static		1Ø	3Ø
18	5.0		 CM18R.N10			 UU18WCR.U00	
24	7.1		 CM24R.N10			 UU24WCR.U20	
30	8.0		 UM30R.N10			 UU30WCR.U20	
36	10.0		 UM36R.N20*			 UU36WCR.U40*	

---

# SINGLE SPLIT



# FEATURE OVERVIEW

Category		Standard inverter (R32)								
kBTu/h		9	12	18	24	30	36	42	48	60
kW		2.5	3.5	5.0	7.1	8.0	10.0	12.5	14.0	15.0
<b>Energy Efficiency</b>	New Type Scroll Compressor						●	●	●	●
	BLDC Comp. & Fan Motor	●	●	●	●	●	●	●	●	●
	Eurovent Certi.	●	●	●	●	●	●	●	●	●
	Variable Voltage Control			●	●	●	●	●	●	●
	Wide Louver Fin	●	●	●	●	●	●	●	●	●
	Optimised Heat Exchanger Path			●	●	●	●	●	●	●
	Power Saving Start up	●	●	●	●	●	●	●	●	●
	Quick Operation Response	●	●	●	●	●	●	●	●	●
	Peak Current Control			●	●	●	●	●	●	●
	Mode Lock	●**	●**	●	●	●	●	●	●	●
Standby Mode	●	●	●	●	●	●	●	●	●	
<b>Durability</b>	Ocean black fin heat exchanger	●	●	●	●	●	●	●	●	●
<b>Fast Cooling &amp; Heating</b>	Forced Cooling Operation			●	●	●	●	●	●	●
<b>Comfort</b>	Night Silent Operation			●	●	●	●	●	●	●
<b>Smart</b>	Outdoor Dry Contact						●	●	●	●
	LG MV	●	●	●	●	●	●	●	●	●
	Weekly Program*	●	●	●	●	●	●	●	●	●
	PI-485 Connection			●	●	●	●	●	●	●
	Wi-Fi Ready***	●	●	●	●	●	●	●	●	●
<b>AHU Solution</b>	Return Air Control			●	●	●	●	●	●	●
	0-10V Supply Air Control			●	●	●	●	●	●	●

\* Weekly program is available with wired remote controller  
 \*\* With controller PREMTB001 / PREMTBB01 / PREMTB100 / PREMTBB10  
 \*\*\* Available with LG Wi-Fi modem(PWFMDD200) and it is applicable to the indoor unit

Category		COMPACT (R32)				STANDARD INVERTER (R410A)	
kBTu/h		18	24	30	36	70	85
kW		5.0	7.1	8.0	10.0	20.0	25.0
<b>Energy Efficiency</b>	New Type Scroll Compressor						
	BLDC Comp. & Fan Motor	●	●	●	●	●	●
	Eurovent Certi.	●	●	●	●	●	●
	Variable Voltage Control					●	●
	Wide Louver Fin	●	●	●	●	●	●
	Optimised Heat Exchanger Path	●	●	●	●	●	●
	Power Saving Start up	●	●	●	●	●	●
	Quick Operation Response	●	●	●	●	●	●
	Peak Current Control					●	●
	Mode Lock	●	●	●	●	●	●
Standby Mode	●	●	●	●	●	●	
<b>Durability</b>	Ocean black fin heat exchanger	●	●	●	●		
<b>Fast Cooling &amp; Heating</b>	Forced Cooling Operation					●	●
<b>Comfort</b>	Night Silent Operation					●	●
<b>Smart</b>	Outdoor Dry Contact					●	●
	LG MV	●	●	●	●	●	●
	Weekly Program*	●**	●**	●	●	●	●
	PI-485 Connection					●	●
	Wi-Fi Ready	●	●	●	●		
<b>AHU Solution</b>	Return Air Control	●	●	●	●	●	●
	0-10V Supply Air Control					●	●

\* Weekly program is available with wired remote controller  
 \*\* With controller PREMTB001 / PREMTBB01



# REVOLUTIONARY SCROLL COMPRESSOR

## R1 Compressor

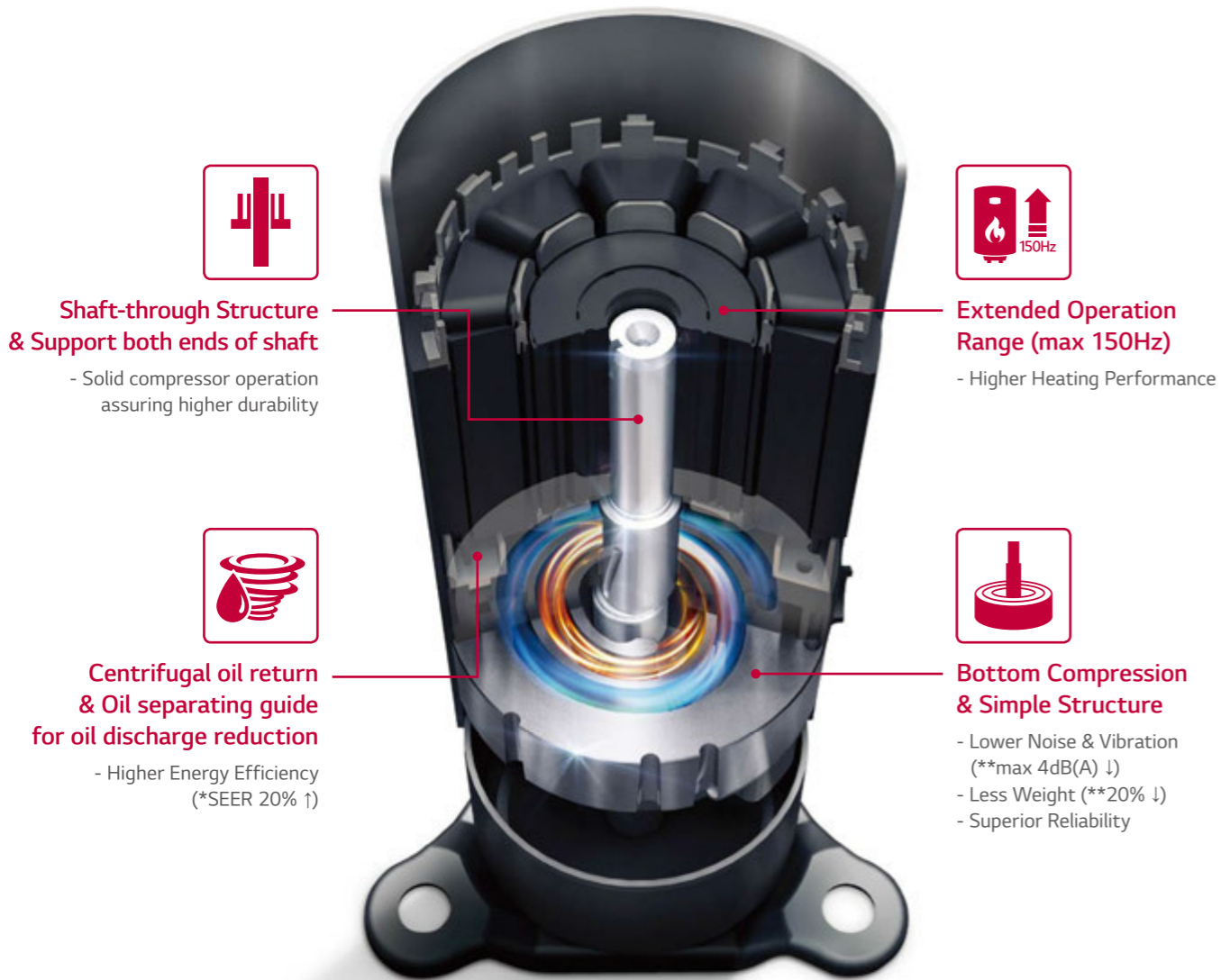

R1 Compressor™

\* LG Internal test result, Based on single split 10 kW Cassette  
 \*\* LG Internal test result, Based on conventional compressor (Rotary type GPT442M)

# ENERGY EFFICIENCY

## Revolutionary Scroll Compressor

Revolutionary Scroll Compressor is applied for high-efficiency and reliability. This type of compressor is more advanced compared to the conventional one. especially tilting motion of scroll has been improved. Further, the operation range is improved compared to the conventional type.

- Scroll compressor with simple structure
- High efficiency (low load at low speed / total efficiency)
- Low noise (high speed possible)
- Improved Tilting Motion of scroll
- 20% weight reduction (vs. conventional compressor)

※ Applied models : UU36WR, UU37WR, UU42WR, UU43WR, UU48WR, UU49WR, UU60WR, UU61WR

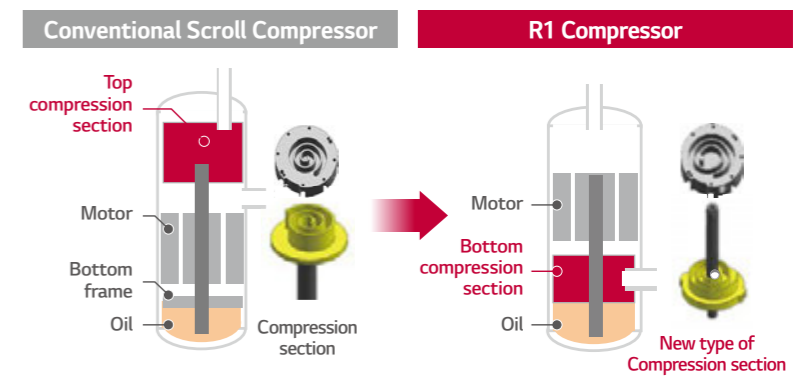

### • Seasonal energy efficiency

SEER 20%, SCOP 13% improvement (vs. rotary)

\* LG Internal test result, Based on single split 10 kW CST

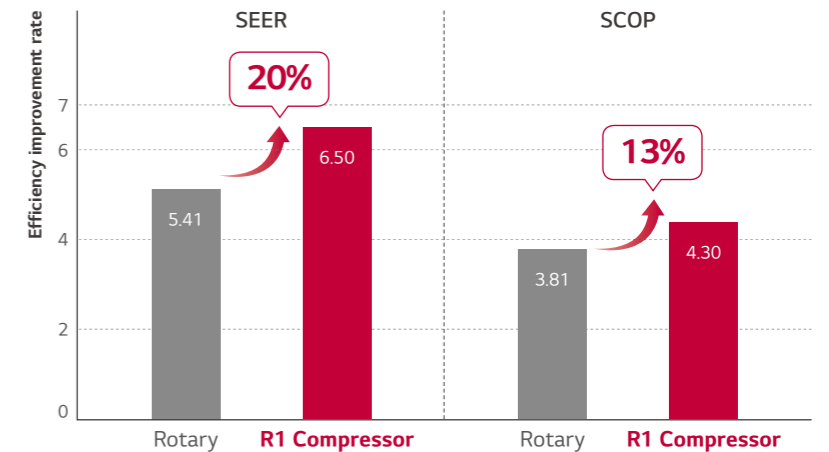

### • Wide Operation Range

- Optimized for various cooling & heat load operation
- World best compressor speed (up to 150 Hz)
- Optimized for even low load operation (down to 10 Hz) (Efficiency increases / Improved comfort)

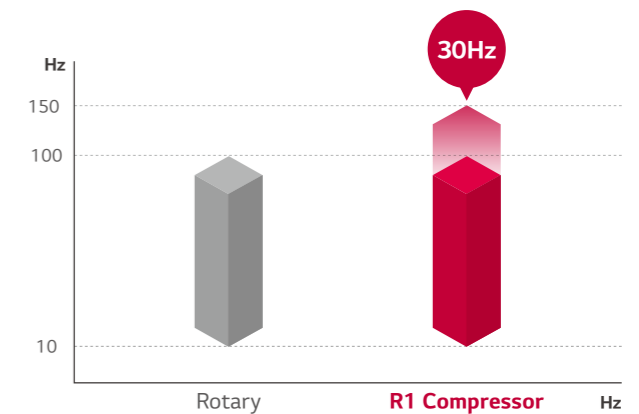

# ENERGY EFFICIENCY

## Power Saving Start Up

LG commercial air conditioners will automatically alter the temperature of discharge air by controlling their refrigerant temperature based on the difference between the indoor temperature and the target indoor temperature. During cooling operation, evaporating temperature will increase if the temperature difference reduces. This leads to extremely comfortable indoor air whilst minimizing energy consumption.

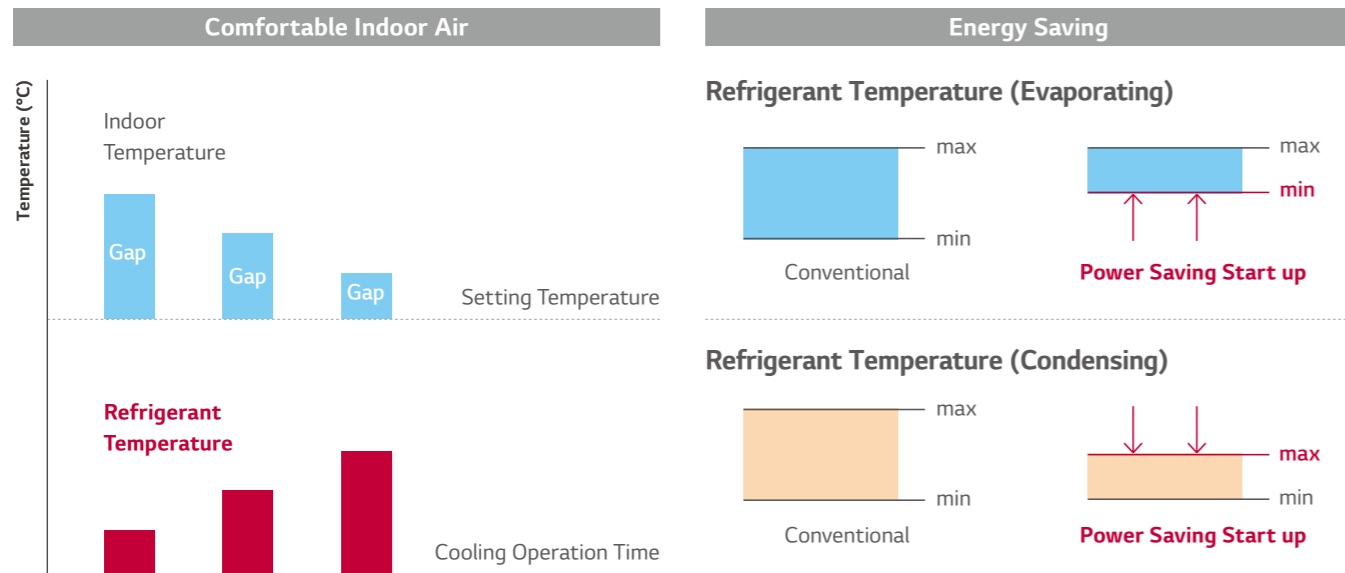

## Quick Operating Response

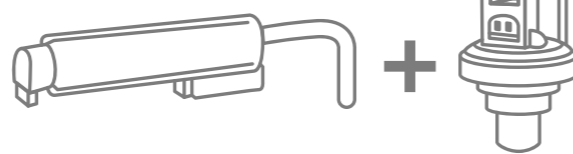
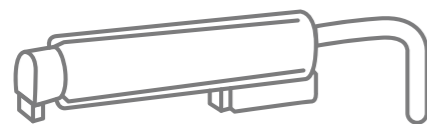

	Conventional	Standard Inverter
<b>Step 1</b>	Detect current temperature of the refrigerant, indoor and outdoor temperature	Detect refrigerant pressure and temperature simultaneously to ensure that the compressor is available for target cooling operation
<b>Step 2</b>	<b>Estimating Pressure</b> Gauge target pressure to operate the compressor, based on the corresponding temperature data	
	This algorithm is more likely to be impacted by temperature change hence consumes more time to calculate proper operation range of compressor to reach target performance point.	This ensures to reach the target performance point operating efficiently and reliably.

## Peak Current Control

The peak current control function prevents the air conditioner from running at the maximum level while maintaining current system settings, in order to reduce energy consumption. This function helps minimize energy costs during the peak periods of energy use when the energy billing is much higher.

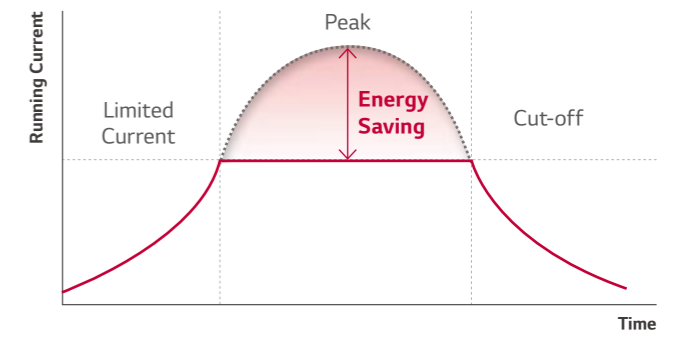

\* Standard Inverter : capacity over 5kW

## Mode Lock

Set the operation mode to either cooling-only or heating-only; either by adjusting the wired remote controller or setting the DIP switch to avoid combined use of cooling and heating. (Some models need wired remote controller for mode lock function according to feature overview table)

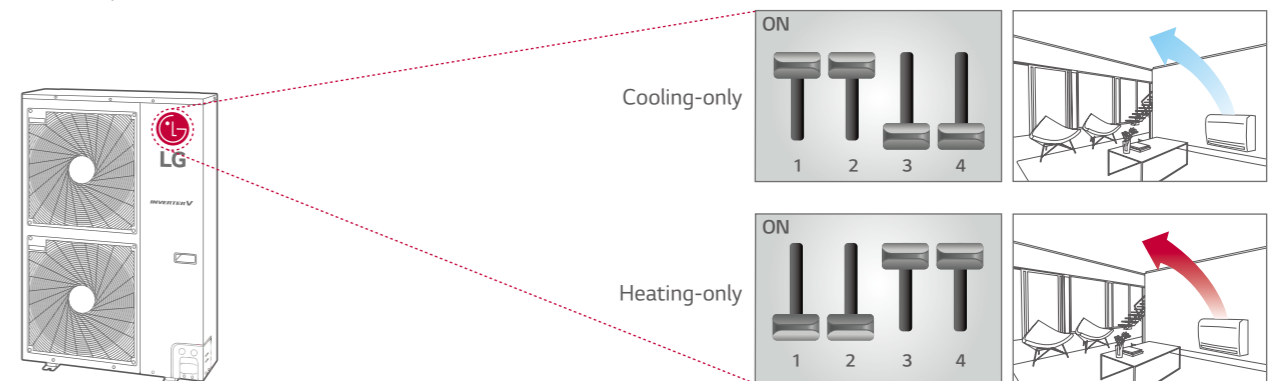

## Standby Mode

Standard Inverter can minimise power consumption by turning power off on the PCB except for the MICOM which receives signals.

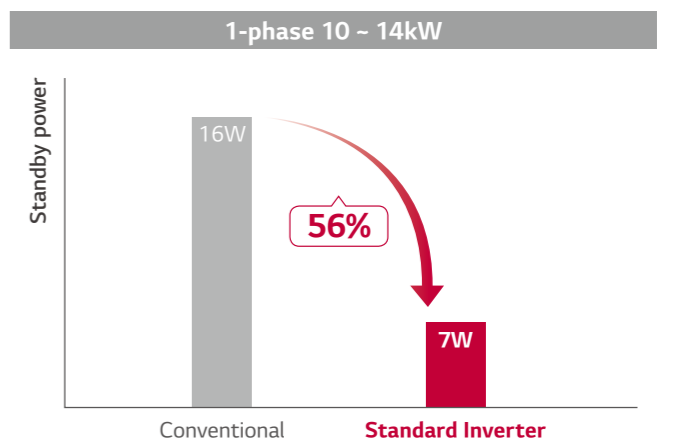

※ The applicable products can be found in the 'Feature Overview'

SINGLE SPLIT KEY FEATURES  
**DURABILITY**

**Ocean Black Fin**

LG's exclusive "Ocean Black Fin" heat exchanger is designed for Improved corrosion resistance.

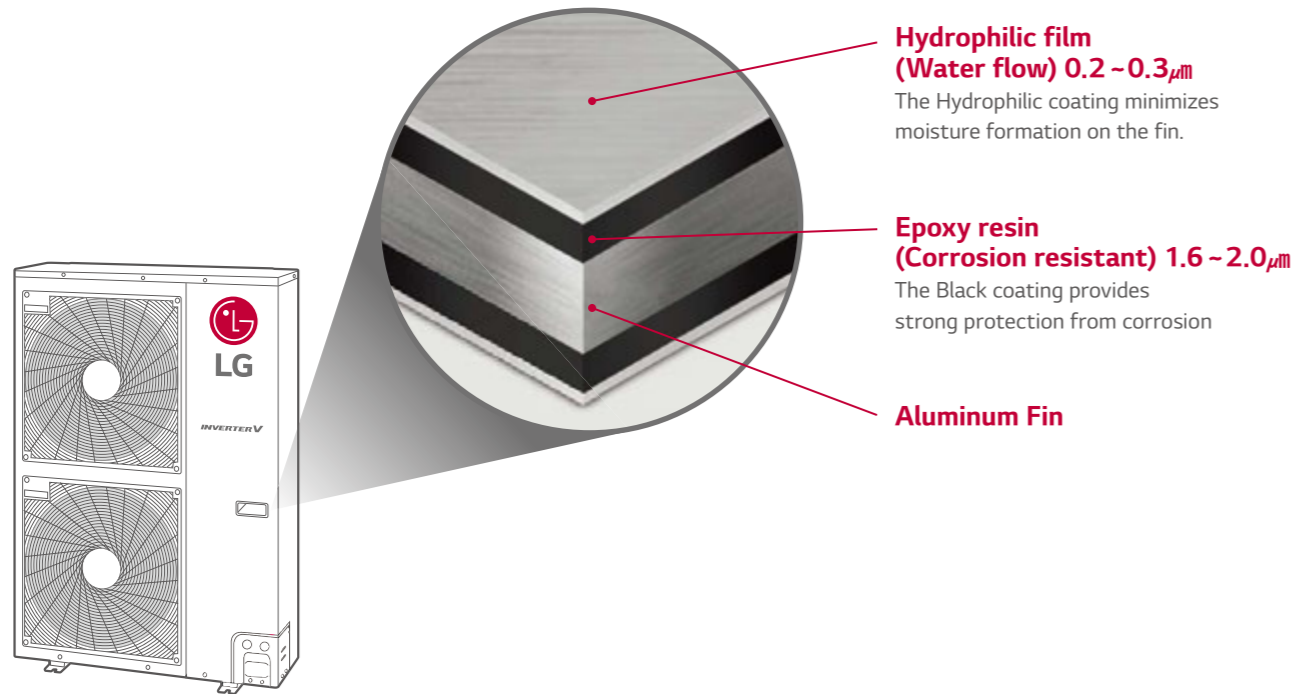

• **Certified protection**



- Test Method B of ISO21207, 6.2 & Annex A
- Test condition: Salt contaminated condition + severe industrial/traffic environment(NO<sub>2</sub>/SO<sub>2</sub>)

\* Based on 1,500 UL test hours

SINGLE SPLIT KEY FEATURES  
**FAST COOLING & HEATING**

**Forced Cooling Operation**

This function allows the refrigerant to be recharged or pumped down, regardless of the indoor temperature. Note that this function can be used when indoor units are being moved or repaired.

**Recharging**

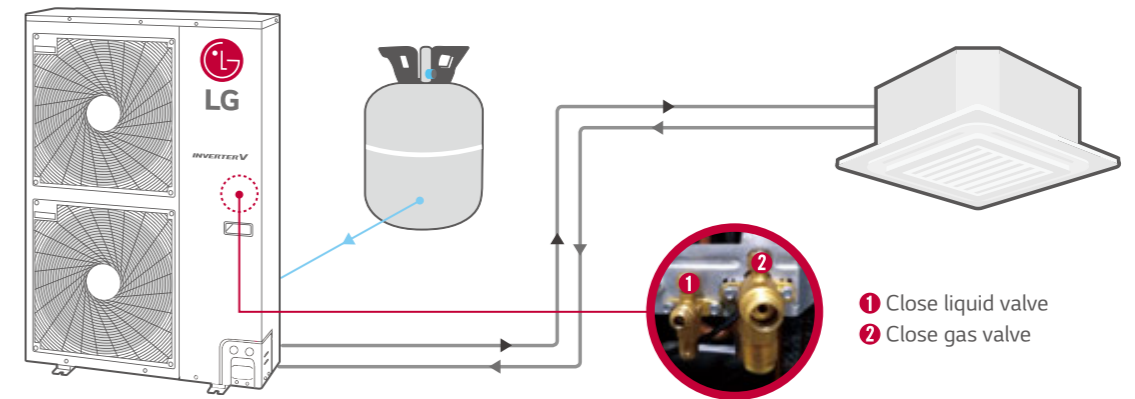

**Pump Down**

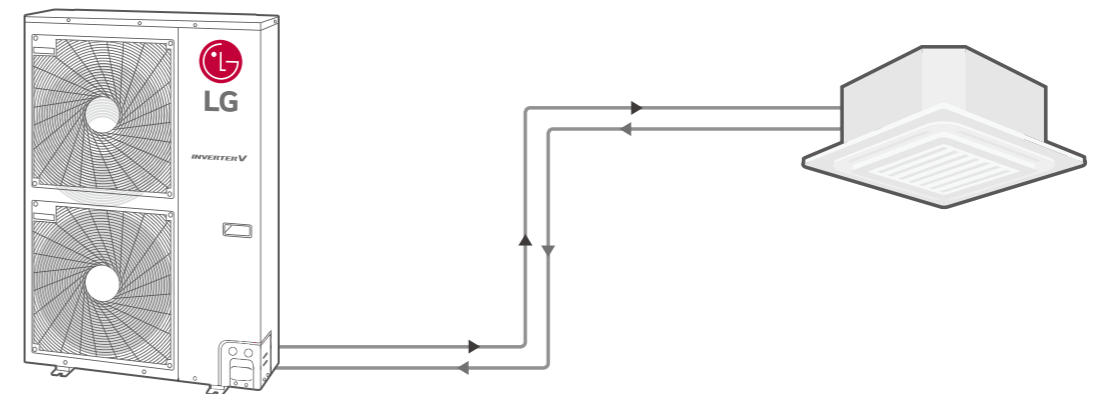

※ The applicable products can be found in the 'Feature Overview'

# COMFORT

## Night Silent Operation

This function enables noise reduction during night time by simply setting the dip switch on the PCB of the outdoor unit.

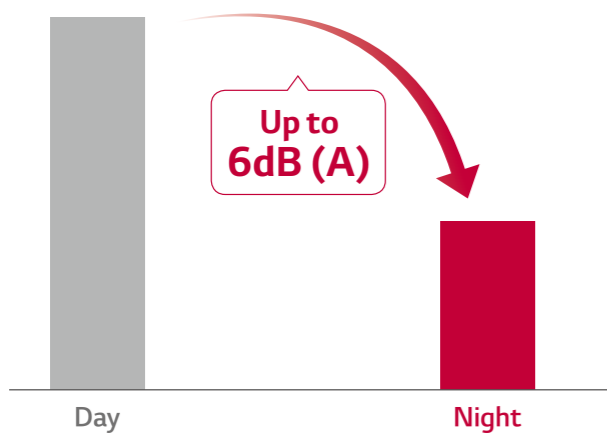
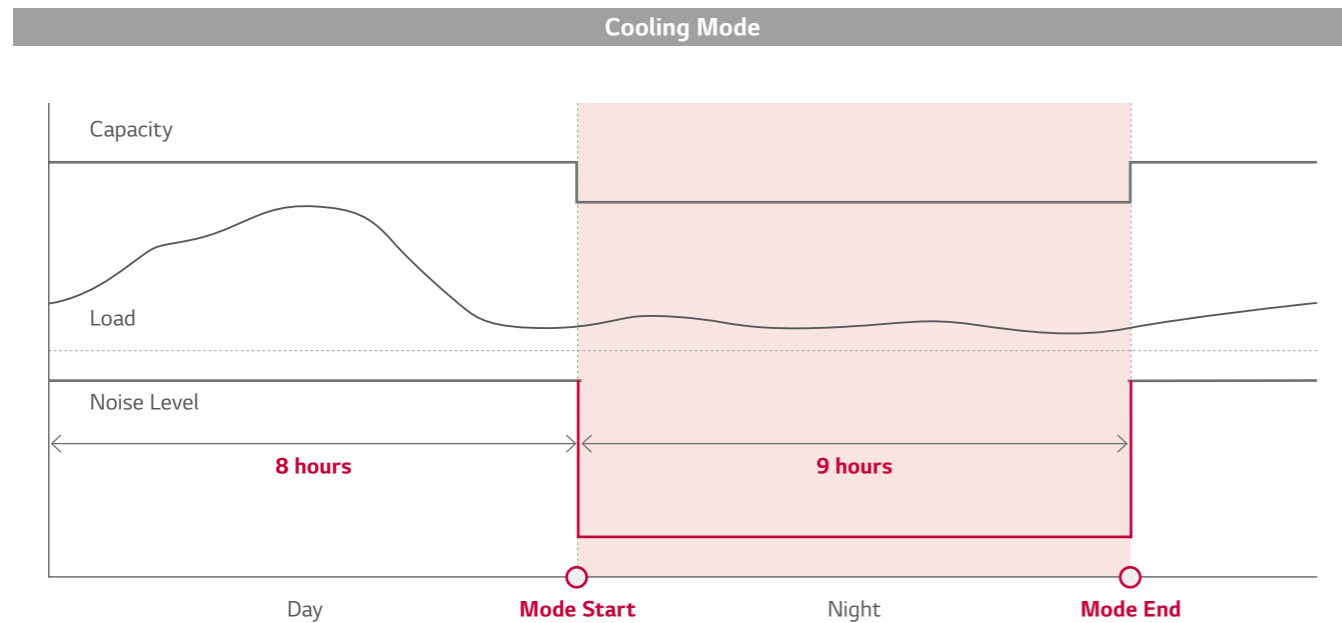

\* This function is only available for Cooling Mode.  
 \* If you want to stop the Night Quiet Mode, Change the Dip Switch.  
 \* LG Internal test result, based on UU37WR

※ The applicable products can be found in the 'Feature Overview'

# SMART

## Outdoor Dry Contact

Air conditioners can be turned ON/OFF at the same time using the ON/OFF dry contact function that outdoor units have. (Models capacity over 10 kW).

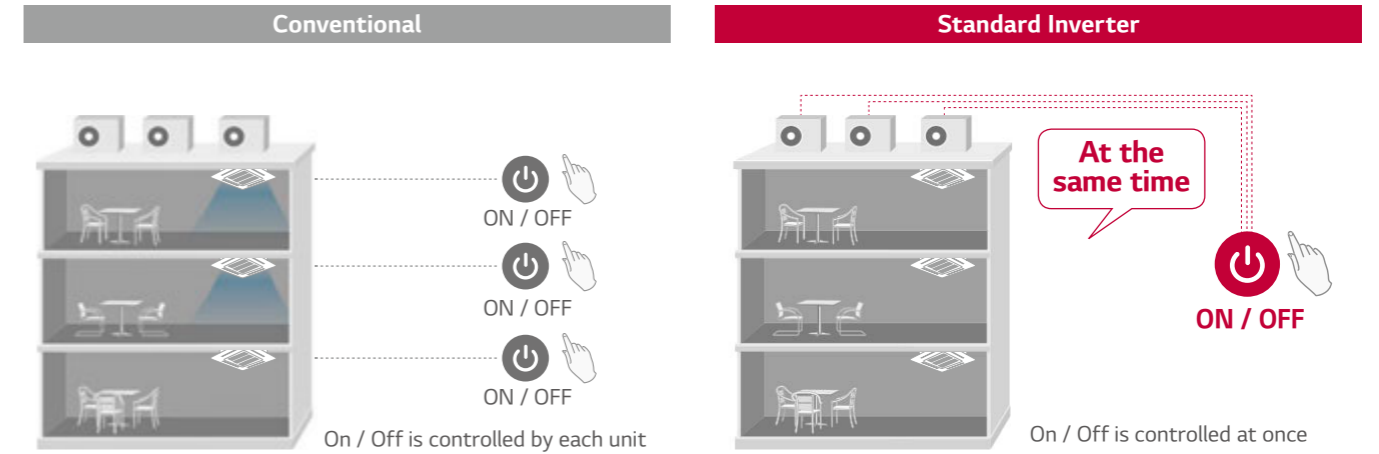

## LG MV (Monitoring View)

LG MV helps engineers to inspect and monitor air conditioning units conveniently. Instructions are provided with the product type. (SINGLE Split & MULTI Split)

The screenshot shows the LG MV monitoring interface with various data tables. To the right, a list of monitoring categories is shown:

- IDU info.
- Cycle & Valves
- Actuator info.
- Sensors & Electricity
- ODU info.

LG MV displays cycle info represented by diagrams. It assists the user to check for data that is concentrated on a graph. A technician can easily obtain info about the error status by looking up the Error Indicator table. (Troubleshooting guide)

### • Error Indicator

ERROR CODE	CONTENTS
01	Air temperature sensor of indoor unit
02	Inlet pipe temperature sensor of indoor unit
03	Communication error : Wired Remote Controller ↔ Indoor Unit
	⋮

# SMART

## Weekly Program

You can allot 2 reservations for one day, and up to 14 reservations for a week.

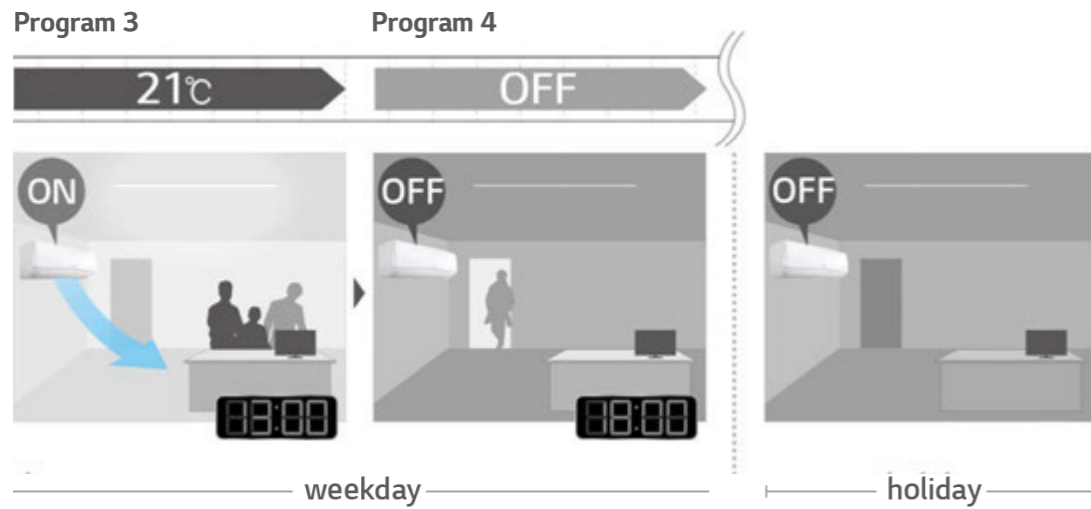
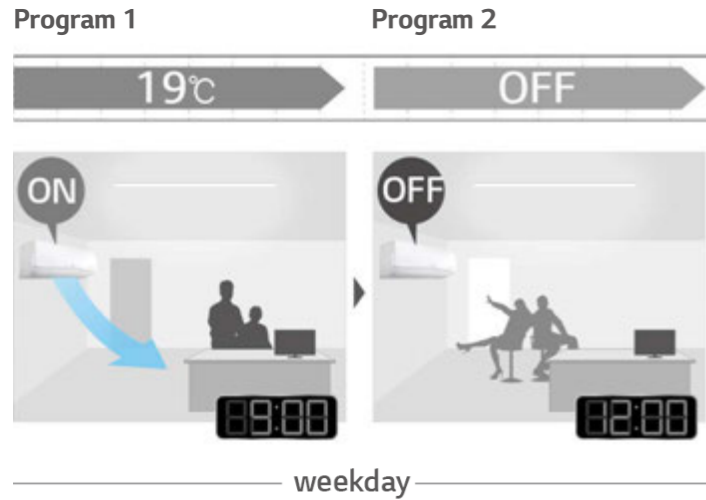

## Wi-fi

Control your air conditioners via using the smart internet devices as Android or iOS based smartphones. Wi-Fi modem (PWFMD200) is required by option.

### • Access your air conditioner anytime and from anywhere

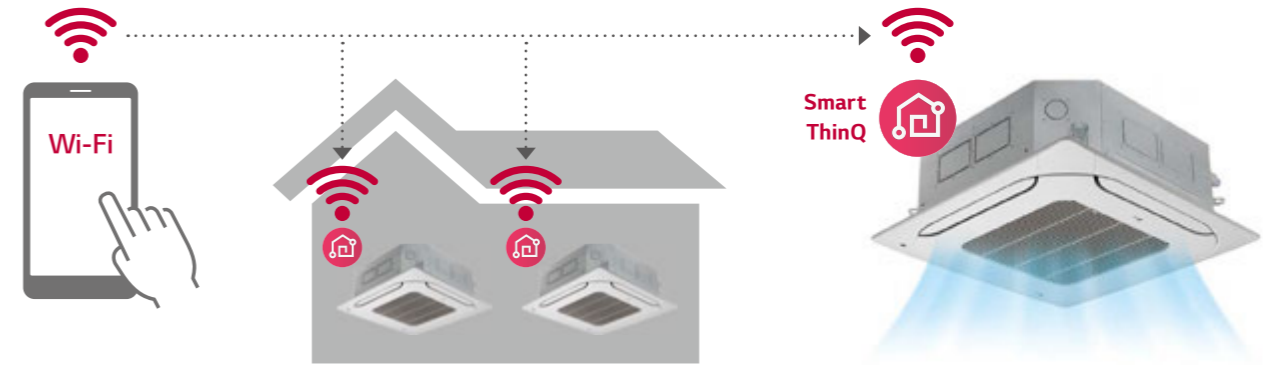

### • Simple operation for various functions

- ON/OFF
- Mode Selection
- Current temperature
- Set temperature
- Vane Control
- Reservation
- Energy Monitoring
- Filter Management

※ Search "LG Smart ThinQ" on Google market or Appstore then download the app.



# PERFORMANCE

## Wide Operation Range

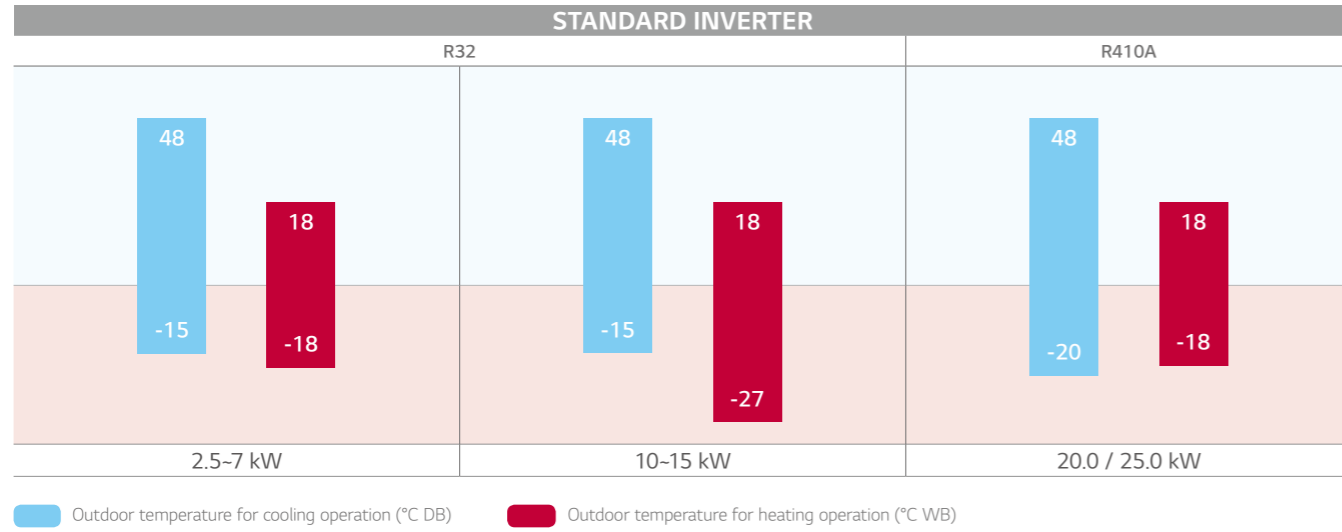

## Stable Operation

High and stable cooling performance at low temperatures.

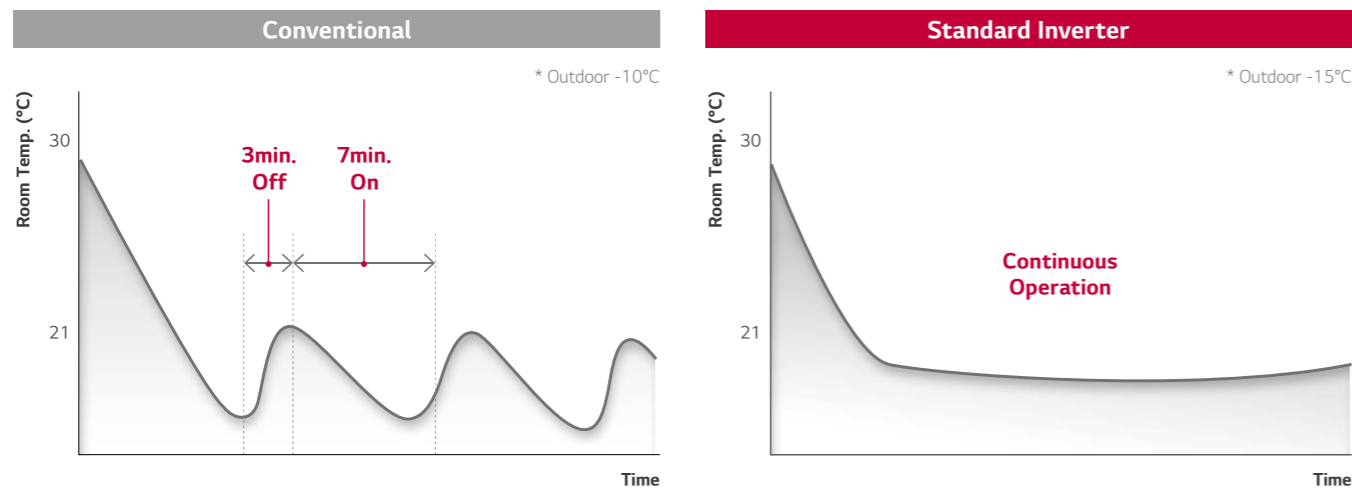

# QUIET OPERATION

## Advanced Grille & Fan

The improved grille shape design on the outdoor unit helps to distribute air more efficiently which improves heat exchange and reduces the noise level. The new axial Fan has a thick front edge and a smooth rear edge, thus providing not only high efficiency, low noise, wide fan, but also improving the air flow rate.

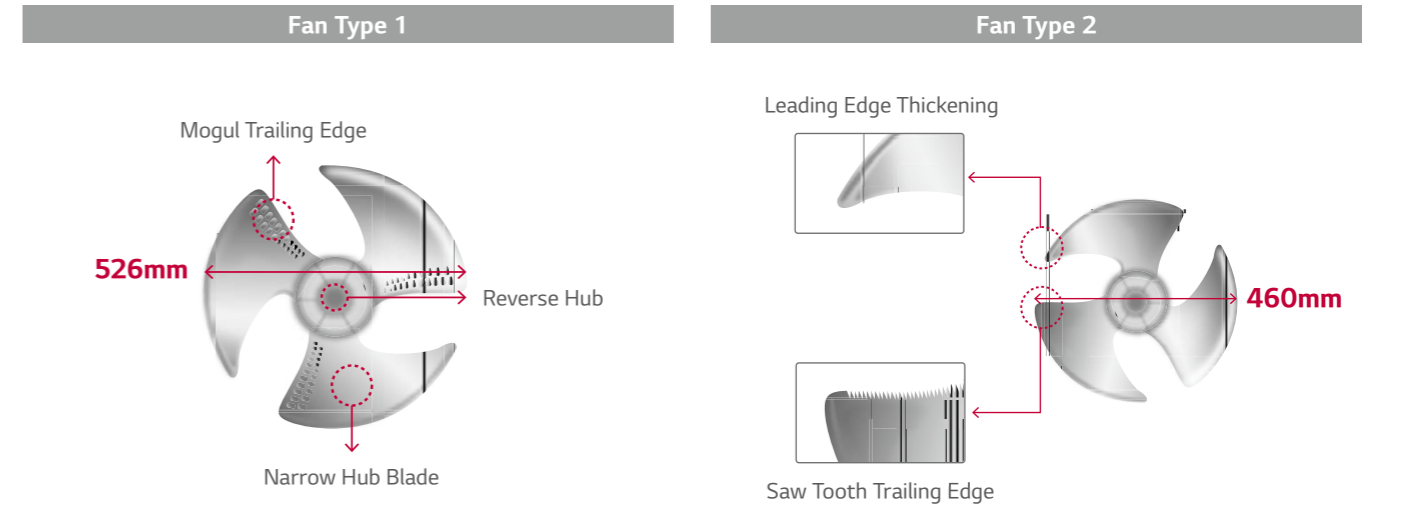
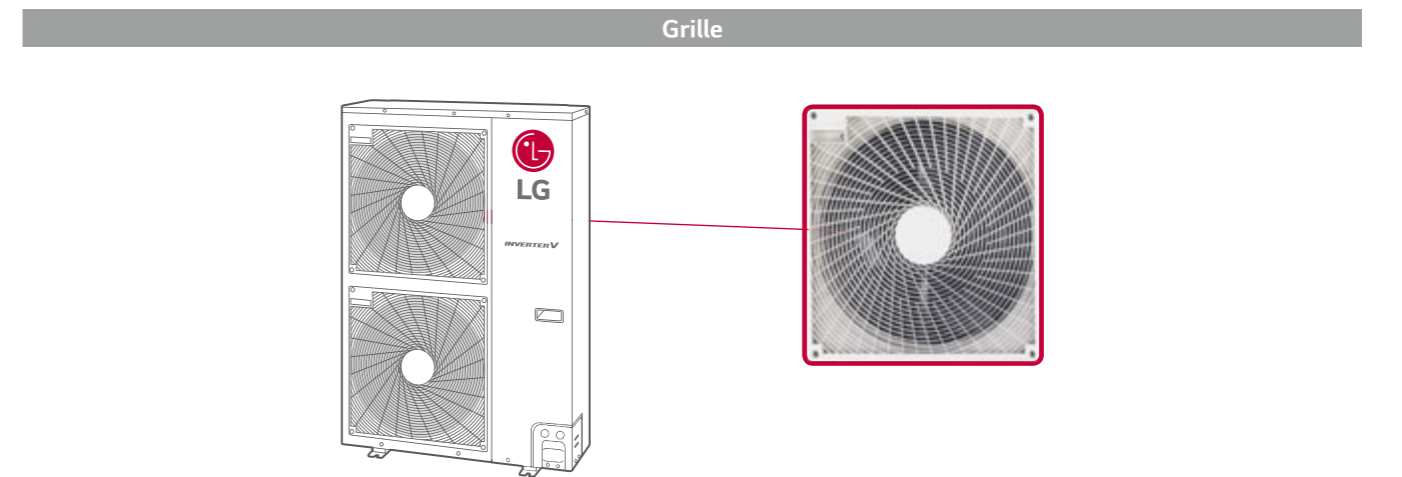

# CEILING MOUNTED CASSETTE



SINGLE SPLIT KEY FEATURES

## CEILING MOUNTED CASSETTE

### Compact Size

The indoor unit with slim and compact dimensions allows successful installation by easily accommodating it in limited space.

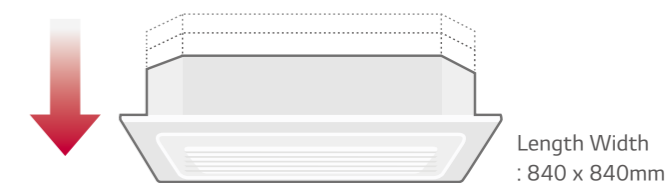

Standard Inverter	Height
7.1 - 8.0kW	204mm
10.0kW	246mm
12.5 - 15kW	288mm

### 620 Panel – Compact and Stylish Design

- New 4 way cassette panel adapted unibody shape and matching with into the ceiling
- Panel size is fit into the ceiling tile

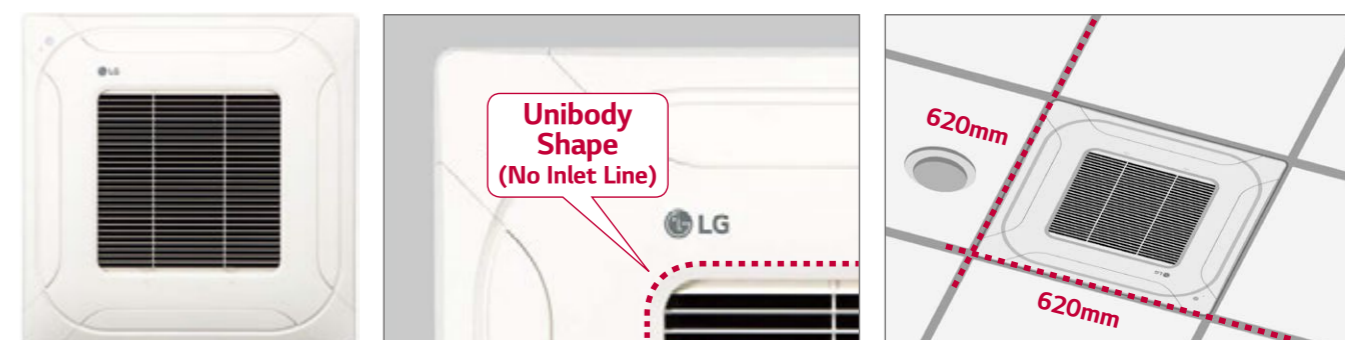

### High Ceiling Mode

High ceiling mode provides powerful cooling and heating up to 4.2m in height, from ceiling to floor.

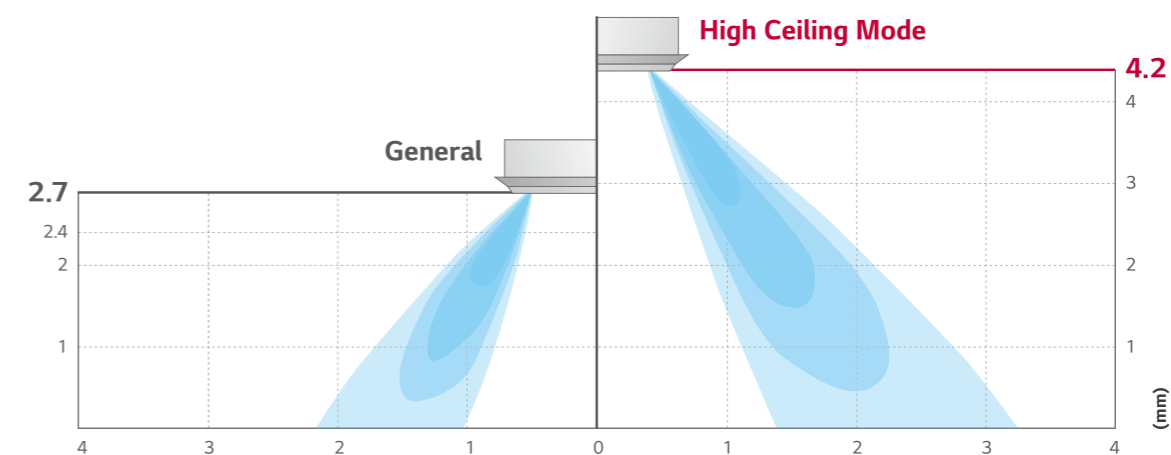

COMMERCIAL

# CEILING MOUNTED CASSETTE

## Human detection sensor & humidity sensor



Human detection sensor (PTVSM10)

### Apply human detection sensor

- Apply vision sensor
- Saving energy
- Supply comfortable air flow
- The sensor is an optional accessory that can only be applied on PT-MCHW0

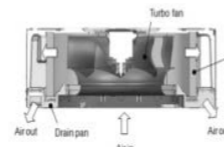

### Comfortable and Power Saving Control based on Humidity

- Apply humidity sensor
- Saving energy
- To apply humidity sensor, new remote controller, PREMTB100 or PREMTBB10 is needed

### • Detection

Motion sensors detect the activity of people per 20seconds



### • Detection range

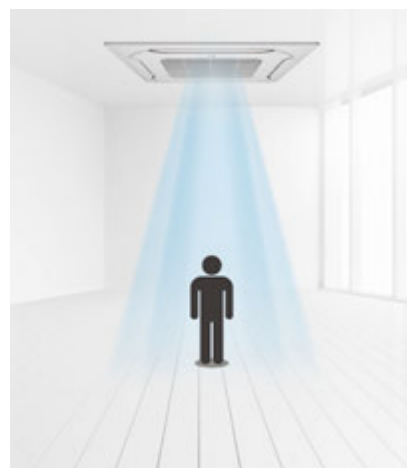

Height 3.2 (15 x 8m)



Height 3.5 (16 x 10m)



A sensor is installed 90° rotation 12 x 6m → 6 x 12m detecting

## 950/620 Panel – Wide Jet Air Flow

Improved vanes reduce the curved area and provide even distribution.

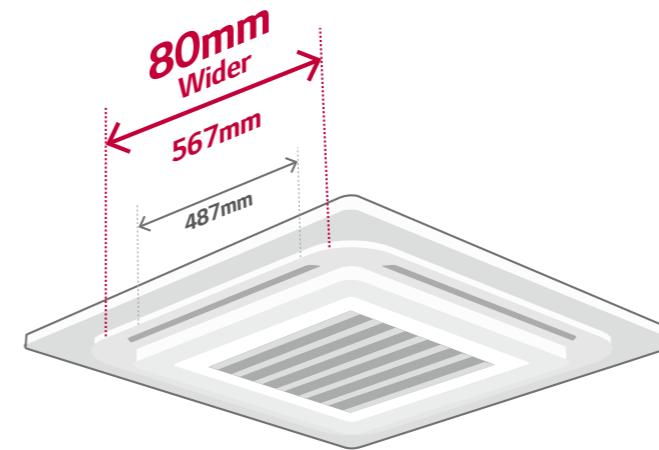

### Conventional



### LG Cassette

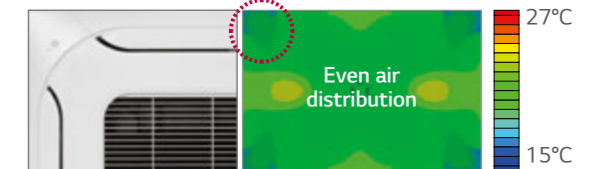

## Independent Vane Operation

The independent vane operation feature uses separate motors, making it possible to control all four vanes independently.

### All Vane Operation

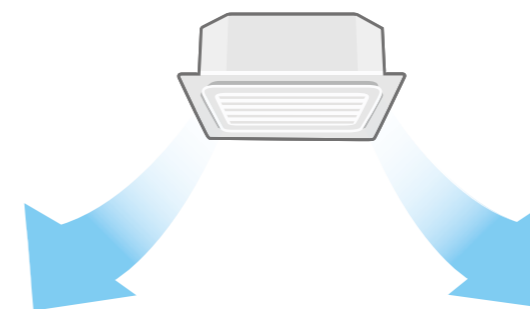

### Independent Vane Control

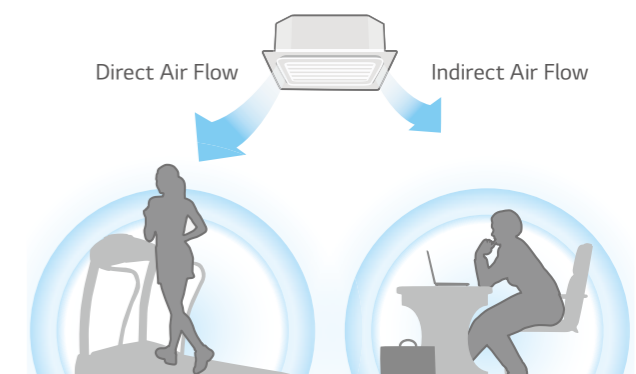



# CEILING MOUNTED CASSETTE

## Convenient Panel Installation

The detachable corner design makes it convenient to adjust the hanger during installation and to check for leakages in the drain connection pipe.

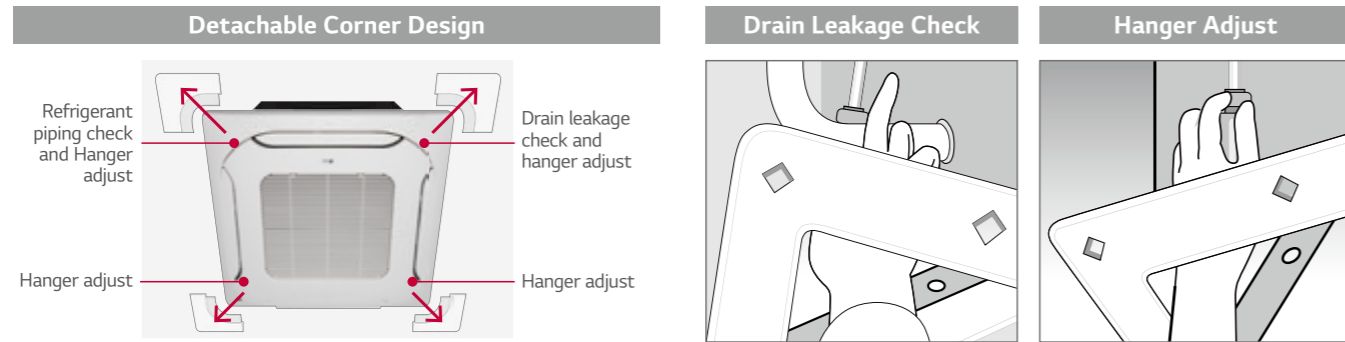

It is easy to attach the panel to the body, using the button type panel design

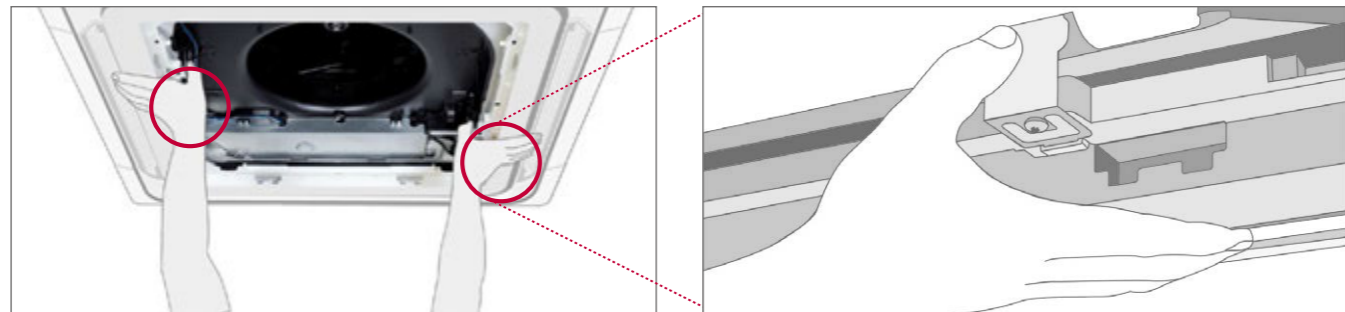

## Auto Elevation Grille

Easy filter cleaning by using the elevation grill.

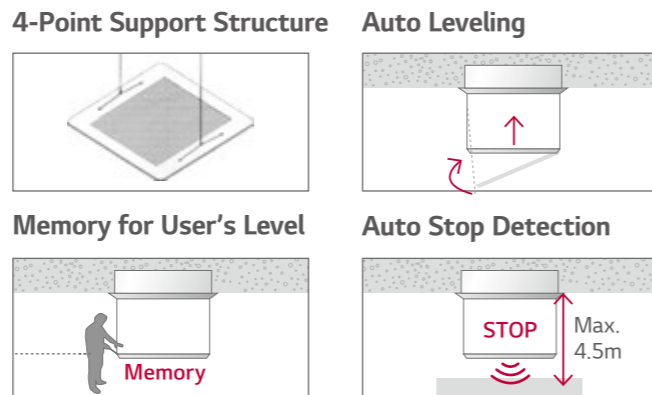

\* Operating with wired remote controller PREMTB100, PREMTB001 and wireless remote controller included in PTEGMO.  
\* Applied to cassette panel PT-UMC1

# CEILING MOUNTED CASSETTE



## STANDARD INVERTER (R32)

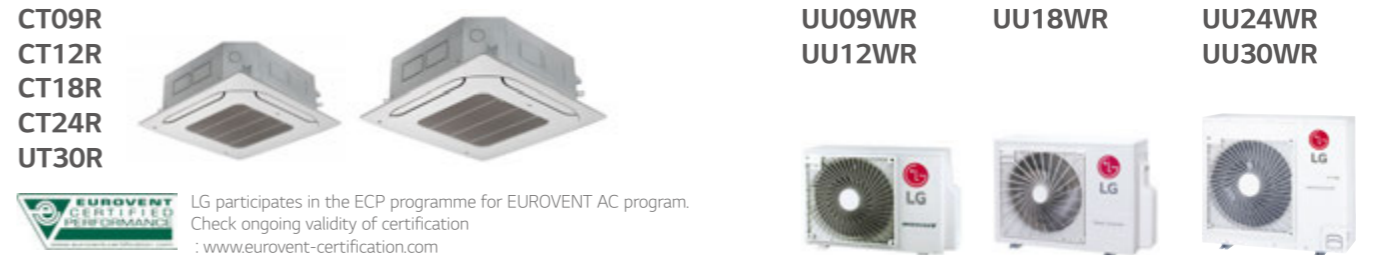

LG participates in the ECP programme for EUROVENT AC program. Check ongoing validity of certification : [www.eurovent-certification.com](http://www.eurovent-certification.com)

INDOOR			CT09R.NR0	CT12R.NR0	CT18R.NQ0	CT24R.NP0	UT30R.NP0*
Capacity	Cooling	Min / Nom / Max	1.0 / 2.5 / 2.8	1.4 / 3.4 / 3.9	2.0 / 5.0 / 5.7	2.84 / 6.8 / 7.8	3.2 / 8.0 / 8.8
	Heating	Min / Nom / Max	1.2 / 3.2 / 3.4	1.6 / 4.0 / 4.6	2.2 / 5.8 / 6.8	3.2 / 8.0 / 8.8	3.6 / 9.0 / 9.9
Low Temperature Capacity	Heating	-7°C Max	2.7	3.6	4.9	7.2	8.1
Power Input (Set)	Cooling	Nom	0.63	0.97	1.56	1.94	2.39
	Heating	Nom	0.75	1.12	1.66	2.00	2.65
Power Input (Indoor)		Min / Nom / Max	10 / 20 / 20	10 / 20 / 20	10 / 30 / 40	20 / 50 / 60	30 / 70 / 80
Running Current	Cooling / Heating	Nom	2.7 / 3.5	4.3 / 5.0	7.1 / 7.5	8.6 / 8.8	10.6 / 11.8
Power Supply		Ø / V / Hz	1 / 220-240 / 50	1 / 220-240 / 50	1 / 220-240 / 50	1 / 220-240 / 50	1 / 220-240 / 50
EER			4.00	3.51	3.21	3.51	3.36
COP			4.00	3.58	3.49	4.00	3.40
SEER			6.77	6.58	6.25	7.70	7.00
SCOP			4.36	4.40	4.25	4.60	4.20
Pdesign (@-10°C)			3.0	3.0	4.1	5.8	6.3
Seasonal Energy Label	Cooling / Heating		A++ / A+	A++ / A+	A++ / A+	A++ / A+	A++ / A+
Annual Energy Consumption	Cooling / Heating	kWh	129 / 963	181 / 955	280 / 1,351	309 / 1,765	400 / 2,100
Piping Connection	Liquid	mm (inch)	Ø 6.35 (1/4)	Ø 6.35 (1/4)	Ø 6.35 (1/4)	Ø 9.52 (3/8)	Ø 9.52 (3/8)
	Gas	mm (inch)	Ø 9.52 (3/8)	Ø 9.52 (3/8)	Ø 12.7 (1/2)	Ø 15.88 (5/8)	Ø 15.88 (5/8)
	Drain	O.D. / I.D.	32 / 25	32 / 25	32 / 25	32 / 25	32.0 / 25.0
Air Flow Rate	High / Medium / Low	m³/min	8.5 / 7.0 / 6.0	9.5 / 8.0 / 7.0	13.0 / 12.0 / 11.0	17.0 / 15.0 / 13.0	19.0 / 17.0 / 15.0
Sound Pressure	Cooling	High / Medium / Low	36 / 33 / 30	38 / 35 / 32	41 / 39 / 36	38 / 36 / 34	40 / 37 / 35
	Max	dBA	52	52	57	57	58
Dehumidification Rate		l/h	0.9	1.4	2.0	2.7	2.5
Dimensions	Body	W x H x D	570 x 214 x 570	570 x 214 x 570	570 x 256 x 570	840 x 204 x 840	840 x 204 x 840
Net Weight	Body	kg	14.0	14.3	20.5	20.5	20.5
Decoration Panel	Model		PT-QCHW0	PT-QCHW0	PT-QCHW0	PT-MCHW0	PT-MCHW0
	Color		Morning Fog	Morning Fog	Morning Fog	Morning Fog	Morning Fog
Dimensions	W x H x D	mm	620 x 20 x 620	620 x 20 x 620	620 x 20 x 620	950 x 35 x 950	950 x 35 x 950
	Weight	kg	3.0	3.0	3.0	6.3	6.3

OUTDOOR			UU09WR.U0	UU12WR.U0	UU18WR.U20	UU24WR.U40	UU30WR.U40*
Compressor	Type		Twin Rotary	Twin Rotary	Twin Rotary	Twin Rotary	Twin Rotary
AirFlow Rate	Nom	m³/min	32	32	50	58	58
	Nom	dBA	47	49	47	48	48
Sound Pressure	Heating	Nom	50	52	52	52	52
	Max	dBA	65	65	63	67	68
Sound Power	Cooling	Max	65	65	63	67	68
Dimensions	W x H x D	mm	770 x 545 x 288	770 x 545 x 288	870 x 650 x 330	950 x 834 x 330	950 x 834 x 330
Net Weight		kg	33.8	33.8	44.8	56.1	58.0
Refrigerant	Type		R32	R32	R32	R32	R32
	Charge	g	900	900	1,100	1,600	1,900
	Additional Charge (after 7.5m)	g/m	20	20	20	35	35
	GWP		675	675	675	675	675
	TCO <sub>2</sub> eq		0.61	0.61	0.74	1.08	1.28
Operation Range (Outdoor)	Cooling	Min / Max	-15 / 48	-15 / 48	-15 / 48	-15 / 48	-15 / 48
	Heating	Min / Max	-18 / 18	-18 / 18	-18 / 18	-18 / 18	-18 / 18
Power Supply		Ø / V / Hz	1 / 220-240 / 50	1 / 220-240 / 50	1 / 220-240 / 50	1 / 220-240 / 50	1 / 220-240 / 50
Power Supply Cable		No. x mm²	3C x 2.5	3C x 2.5	3C x 2.5	3C x 2.5	3C x 2.5
Transmission Cable		No. x mm²	4C x 0.75	4C x 0.75	4C x 0.75	4C x 0.75	4C x 0.75
Circuit Breaker		A	15	15	20	25	25
Piping Length Total		Min / Max	5 / 20	5 / 20	5 / 30	5 / 50	5 / 50
Piping Elevation Difference	IDU - ODU	Max	15	15	30	30	30
Piping Connection	Liquid	mm (inch)	Ø 6.35 (1/4)	Ø 6.35 (1/4)	Ø 6.35 (1/4)	Ø 9.52 (3/8)	Ø 9.52 (3/8)
	Gas	mm (inch)	Ø 9.52 (3/8)	Ø 9.52 (3/8)	Ø 12.7 (1/2)	Ø 15.88 (5/8)	Ø 15.88 (5/8)

\* Available from April 2019.  
 ※ For our policy of continuous product improvement, specification, design and features are subject to change without prior notice.  
 Note : 1. Due to our policy of innovation some specifications may be changed without notification.  
 2. Definition of Power Input Nominal conditions – Performance tested under EN14511  
 3. Capacities are based on the following conditions : Cooling : - Indoor Temperature 27°C DB / 19°C WB - Outdoor Temperature 35°C DB / 24°C WB  
 Heating : - Indoor Temperature 20°C DB / 15°C WB - Outdoor Temperature 7°C DB / 6°C WB  
 4. Annual energy consumption : based on average use of 350 running hours in cooling and 1,400 hours in heating per year at seasonal condition  
 5. This product contains fluorinated greenhouse gases (R32)

# CEILING MOUNTED CASSETTE



## STANDARD INVERTER (R32)

UT36R  
UT42R  
UT48R  
UT60R



UU36WR / UU42WR  
UU48WR / UU60WR



LG participates in the ECP programme for EUROVENT AC program.  
Check ongoing validity of certification  
: www.eurovent-certification.com

INDOOR			UT36R.NMO	UT42R.NMO	UT48R.NMO	UT60R.NMO
Capacity	Cooling	Min / Nom / Max	4.5 / 9.5 / 13.0	5.0 / 12.0 / 14.5	5.5 / 13.4 / 16.0	5.9 / 14.6 / 16.3
	Heating	Min / Nom / Max	5.0 / 10.8 / 13.7	5.5 / 13.5 / 16.5	6.1 / 15.5 / 18.0	6.8 / 16.9 / 18.7
Low Temperature Capacity	Heating -7°C	Max	9.8	12.5	14.3	15.2
		kW	9.8	12.5	14.3	15.2
Power Input (Set)	Cooling	Nom	2.47	3.50	4.35	5.38
	Heating	Nom	2.80	3.75	4.82	5.60
Power Input (Indoor)		Min / Nom / Max	40 / 190 / 210	40 / 190 / 210	40 / 190 / 210	40 / 190 / 210
Running Current	Cooling / Heating	Nom	10.7 / 12.2	15.2 / 16.3	18.9 / 21.0	23.4 / 24.3
Power Supply		Ø / V / Hz	1 / 220-240 / 50	1 / 220-240 / 50	1 / 220-240 / 50	1 / 220-240 / 50
EER			3.85	3.43	3.08	2.71
COP			3.86	3.60	3.22	3.02
SEER			6.50	6.10	5.87	5.57
SCOP			4.30	4.10	4.04	3.92
Pdesign (@-10°C)		kW	8.05	8.05	9.30	9.30
Seasonal Energy Label	Cooling / Heating		A++ / A+	A++ / A+	-	-
Annual Energy Consumption	Cooling / Heating	kWh	512 / 2,605	689 / 2,732	1,370 / 3,223	1,573 / 3,321
Piping Connection	Liquid	mm (inch)	Ø 9.52 (3/8)	Ø 9.52 (3/8)	Ø 9.52 (3/8)	Ø 9.52 (3/8)
	Gas	mm (inch)	Ø 15.88 (5/8)	Ø 15.88 (5/8)	Ø 15.88 (5/8)	Ø 15.88 (5/8)
	Drain	O.D. / I.D.	32 / 25	32 / 25	32 / 25	32 / 25
Air Flow Rate		High / Medium / Low	30.0 / 25.0 / 20.0	33.0 / 28.0 / 22.0	33.0 / 28.0 / 22.0	33.0 / 28.0 / 22.0
Sound Pressure	Cooling	High / Medium / Low	46 / 43 / 40	47 / 44 / 41	47 / 44 / 41	47 / 44 / 41
Sound Power	Cooling	Max	62	64	64	66
Dehumidification Rate		l/h	2.7	4.2	5.2	6.2
Dimensions	Body	W x H x D	840 x 288 x 840	840 x 288 x 840	840 x 288 x 840	840 x 288 x 840
Net Weight	Body	kg	24.6	24.6	24.6	24.6
	Model		PT-MCHW0	PT-MCHW0	PT-MCHW0	PT-MCHW0
Decoration Panel	Color		Morning Fog	Morning Fog	Morning Fog	Morning Fog
	Dimensions	W x H x D	950 x 35 x 950	950 x 35 x 950	950 x 35 x 950	950 x 35 x 950
	Weight	kg	6.3	6.3	6.3	6.3

OUTDOOR			UU36WR.U30	UU42WR.U30	UU48WR.U30	UU60WR.U30
Compressor	Type		R-Scroll	R-Scroll	R-Scroll	R-Scroll
Airflow Rate	Nom	m <sup>3</sup> /min	110	110	110	110
Sound Pressure	Cooling	Nom	52	52	52	52
	Heating	Nom	54	54	54	54
Sound Power	Cooling	Max	66	67	68	68
Dimensions	W x H x D	mm	950 x 1,380 x 330	950 x 1,380 x 330	950 x 1,380 x 330	950 x 1,380 x 330
Net Weight		kg	87.5	87.5	87.5	87.5
	Type		R32	R32	R32	R32
Refrigerant	Charge	g	3,000	3,000	3,000	3,000
	Additional Charge (after 7.5m)	g/m	40	40	40	40
	GWP		675	675	675	675
	TCO <sub>2</sub> eq		2.03	2.03	2.03	2.03
Operation Range (Outdoor)	Cooling	Min / Max	-15 / 48	-15 / 48	-15 / 48	-15 / 48
	Heating	Min / Max	-27 / 18	-27 / 18	-27 / 18	-27 / 18
Power Supply		Ø / V / Hz	1 / 220-240 / 50	1 / 220-240 / 50	1 / 220-240 / 50	1 / 220-240 / 50
Power Supply Cable		No. x mm <sup>2</sup>	3C x 6.0	3C x 6.0	3C x 6.0	3C x 6.0
Transmission Cable		No. x mm <sup>2</sup>	4C x 0.75	4C x 0.75	4C x 0.75	4C x 0.75
Circuit Breaker		A	40	40	40	40
Piping Length Total		Min / Max	5 / 85	5 / 85	5 / 85	5 / 85
Piping Elevation Difference	IDU - ODU	Max	30	30	30	30
Piping Connection	Liquid	mm (inch)	Ø 9.52 (3/8)	Ø 9.52 (3/8)	Ø 9.52 (3/8)	Ø 9.52 (3/8)
	Gas	mm (inch)	Ø 15.88 (5/8)	Ø 15.88 (5/8)	Ø 15.88 (5/8)	Ø 15.88 (5/8)

※ For our policy of continuous product improvement, specification, design and features are subject to change without prior notice.  
 Note : 1. Due to our policy of innovation some specifications may be changed without notification.  
 2. Definition of Power Input Nominal conditions – Performance tested under EN14511  
 3. Capacities are based on the following conditions : Cooling : - Indoor Temperature 27°C DB / 19°C WB - Outdoor Temperature 35°C DB / 24°C WB  
 Heating : - Indoor Temperature 20°C DB / 15°C WB - Outdoor Temperature 7°C DB / 6°C WB  
 4. Annual energy consumption : based on average use of 350 running hours in cooling and 1,400 hours in heating per year at seasonal condition  
 5. This product contains fluorinated greenhouse gases (R32)

## STANDARD INVERTER (R32)

UT36R  
UT42R  
UT48R  
UT60R



UU37WR / UU43WR  
UU49WR / UU61WR



LG participates in the ECP programme for EUROVENT AC program.  
Check ongoing validity of certification  
: www.eurovent-certification.com



INDOOR			UT36R.NMO	UT42R.NMO	UT48R.NMO	UT60R.NMO
Capacity	Cooling	Min / Nom / Max	4.5 / 9.5 / 13.0	5.0 / 12.0 / 14.5	5.5 / 13.4 / 16.0	5.9 / 14.6 / 16.3
	Heating	Min / Nom / Max	5.0 / 10.8 / 13.7	5.5 / 13.5 / 16.5	6.1 / 15.5 / 18.0	6.8 / 16.9 / 18.7
Low Temperature Capacity	Heating -7°C	Max	9.8	12.5	14.3	15.2
		kW	9.8	12.5	14.3	15.2
Power Input (Set)	Cooling	Nom	2.47	3.50	4.35	5.38
	Heating	Nom	2.80	3.75	4.82	5.60
Power Input (Indoor)		Min / Nom / Max	40 / 190 / 210	40 / 190 / 210	40 / 190 / 210	40 / 190 / 210
Running Current	Cooling / Heating	Nom	3.6 / 4.0	5.1 / 5.4	5.8 / 6.4	7.8 / 8.1
Power Supply		Ø / V / Hz	1 / 220-240 / 50	1 / 220-240 / 50	1 / 220-240 / 50	1 / 220-240 / 50
EER			3.85	3.43	3.08	2.71
COP			3.86	3.60	3.22	3.02
SEER			6.50	6.18	5.87	5.57
SCOP			4.30	4.17	4.04	3.92
Pdesign (@-10°C)		kW	8.05	8.05	9.30	9.30
Seasonal Energy Label	Cooling / Heating		A++ / A+	A++ / A+	-	-
Annual Energy Consumption	Cooling / Heating	kWh	512 / 2,605	689 / 2,732	1,370 / 3,223	1,573 / 3,321
Piping Connection	Liquid	mm (inch)	Ø 9.52 (3/8)	Ø 9.52 (3/8)	Ø 9.52 (3/8)	Ø 9.52 (3/8)
	Gas	mm (inch)	Ø 15.88 (5/8)	Ø 15.88 (5/8)	Ø 15.88 (5/8)	Ø 15.88 (5/8)
	Drain	O.D. / I.D.	32 / 25	32 / 25	32 / 25	32 / 25
Air Flow Rate		High / Medium / Low	30.0 / 25.0 / 20.0	33.0 / 28.0 / 22.0	33.0 / 28.0 / 22.0	33.0 / 28.0 / 22.0
Sound Pressure	Cooling	High / Medium / Low	46 / 43 / 40	47 / 44 / 41	47 / 44 / 41	47 / 44 / 41
Sound Power	Cooling	Max	62	64	64	66
Dehumidification Rate		l/h	2.7	4.2	5.2	6.2
Dimensions	Body	W x H x D	840 x 288 x 840	840 x 288 x 840	840 x 288 x 840	840 x 288 x 840
Net Weight	Body	kg	24.6	24.6	24.6	24.6
	Model		PT-MCHW0	PT-MCHW0	PT-MCHW0	PT-MCHW0
Decoration Panel	Color		Morning Fog	Morning Fog	Morning Fog	Morning Fog
	Dimensions	W x H x D	950 x 35 x 950	950 x 35 x 950	950 x 35 x 950	950 x 35 x 950
	Weight	kg	6.3	6.3	6.3	6.3

OUTDOOR			UU37WR.U30	UU43WR.U30	UU49WR.U30	UU61WR.U30
Compressor	Type		R-Scroll	R-Scroll	R-Scroll	R-Scroll
Airflow Rate	Nom	m <sup>3</sup> /min	110	110	110	110
Sound Pressure	Cooling	Nom	52	52	52	52
	Heating	Nom	54	54	54	54
Sound Power	Cooling	Max	66	67	68	68
Dimensions	W x H x D	mm	950 x 1,380 x 330	950 x 1,380 x 330	950 x 1,380 x 330	950 x 1,380 x 330
Net Weight		kg	87.5	87.5	87.5	87.5
	Type		R32	R32	R32	R32
Refrigerant	Charge	g	3,000	3,000	3,000	3,000
	Additional Charge (after 7.5m)	g/m	40	40	40	40
	GWP		675	675	675	675
	TCO <sub>2</sub> eq		2.03	2.03	2.03	2.03
Operation Range (Outdoor)	Cooling	Min / Max	-15 / 48	-15 / 48	-15 / 48	-15 / 48
	Heating	Min / Max	-27 / 18	-27 / 18	-27 / 18	-27 / 18
Power Supply		Ø / V / Hz	3 / 380-415 / 50	3 / 380-415 / 50	3 / 380-415 / 50	3 / 380-415 / 50
Power Supply Cable		No. x mm <sup>2</sup>	5C x 2.5	5C x 2.5	5C x 2.5	5C x 2.5
Transmission Cable		No. x mm <sup>2</sup>	4C x 0.75	4C x 0.75	4C x 0.75	4C x 0.75
Circuit Breaker		A	20	40	20	20
Piping Length Total		Min / Max	5 / 85	5 / 85	5 / 85	5 / 85
Piping Elevation Difference	IDU - ODU	Max	30	30	30	30
Piping Connection	Liquid	mm (inch)	Ø 9.52 (3/8)	Ø 9.52 (3/8)	Ø 9.52 (3/8)	Ø 9.52 (3/8)
	Gas	mm (inch)	Ø 15.88 (5/8)	Ø 15.88 (5/8)	Ø 15.88 (5/8)	Ø 15.88 (5/8)

※ For our policy of continuous product improvement, specification, design and features are subject to change without prior notice.  
 Note : 1. Due to our policy of innovation some specifications may be changed without notification.  
 2. Definition of Power Input Nominal conditions – Performance tested under EN14511  
 3. Capacities are based on the following conditions : Cooling : - Indoor Temperature 27°C DB / 19°C WB - Outdoor Temperature 35°C DB / 24°C WB  
 Heating : - Indoor Temperature 20°C DB / 15°C WB - Outdoor Temperature 7°C DB / 6°C WB  
 4. Annual energy consumption : based on average use of 350 running hours in cooling and 1,400 hours in heating per year at seasonal condition  
 5. This product contains fluorinated greenhouse gases (R32)

# CEILING CONCEALED DUCT



SINGLE SPLIT KEY FEATURES

## CEILING CONCEALED DUCT

### E.S.P. (External Static Pressure) Control

This function easily controls volume of the air by a remote controller. The BLDC motor can control fan speed and air volume regardless of the external static pressure. Additional accessories are not required to control air flow.

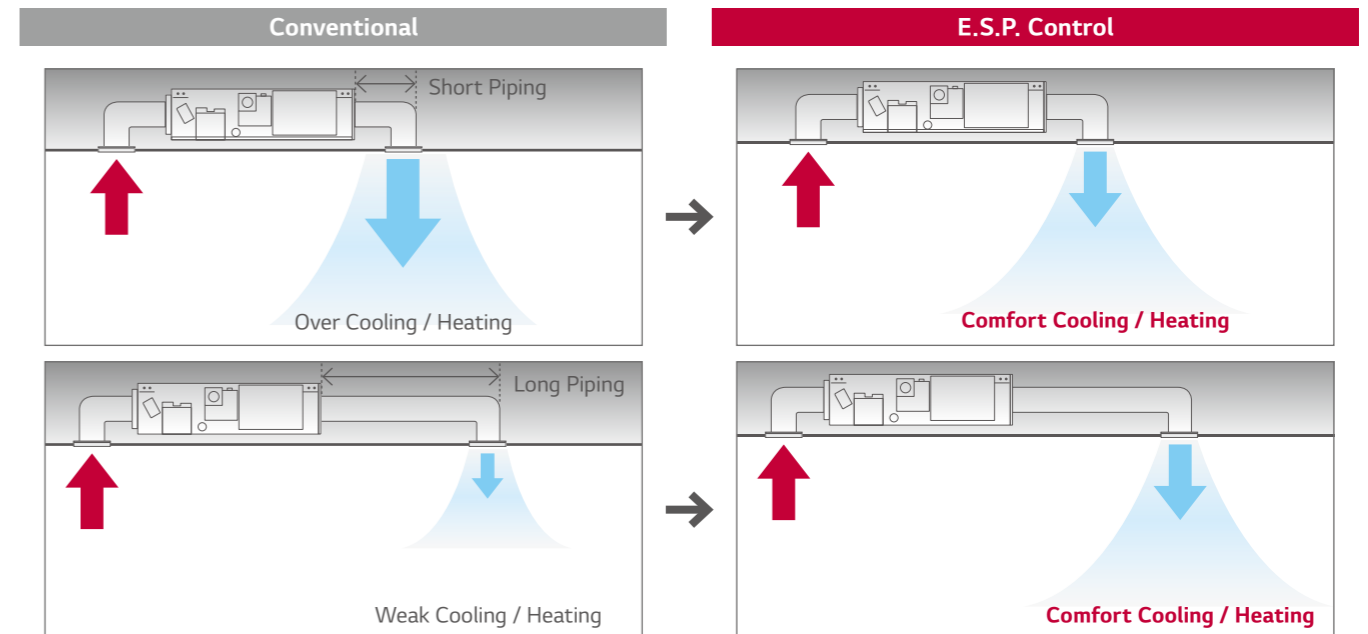

### High Head Drain Pump

High head drain pump automatically drains water up to a height of 200mm of drain-head height. It provides the perfect solution for draining of water. (Standard Inverter : Accessory (ABDPG) / Low-Static Duct : Included)

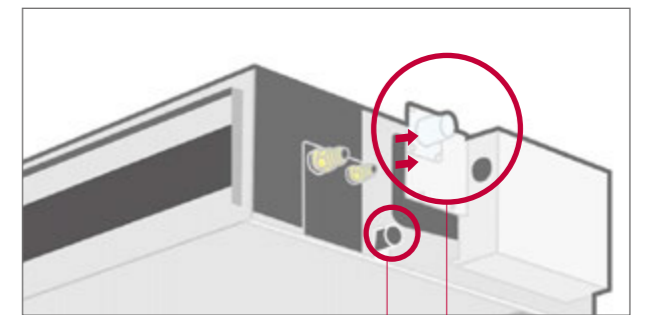
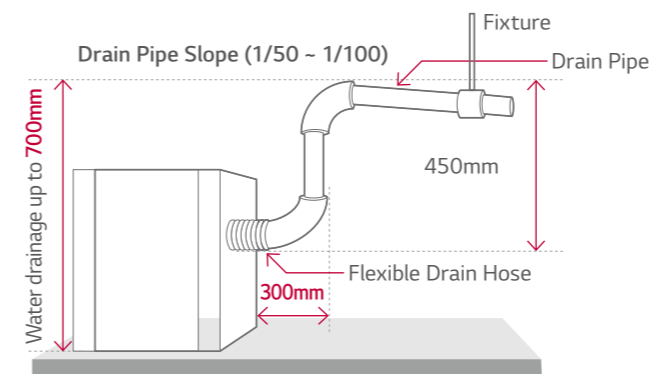

Available for Natural Drainage  
Detachable Drain Pump

# CEILING CONCEALED DUCT

## Two Thermistors Control

The indoor temperature can be checked using the thermistors in the remote controller as well as from the indoor unit. There may be a significant difference between ceiling and floor air temperature. Two thermistors can optimise indoor air temperature for a more comfortable environment.

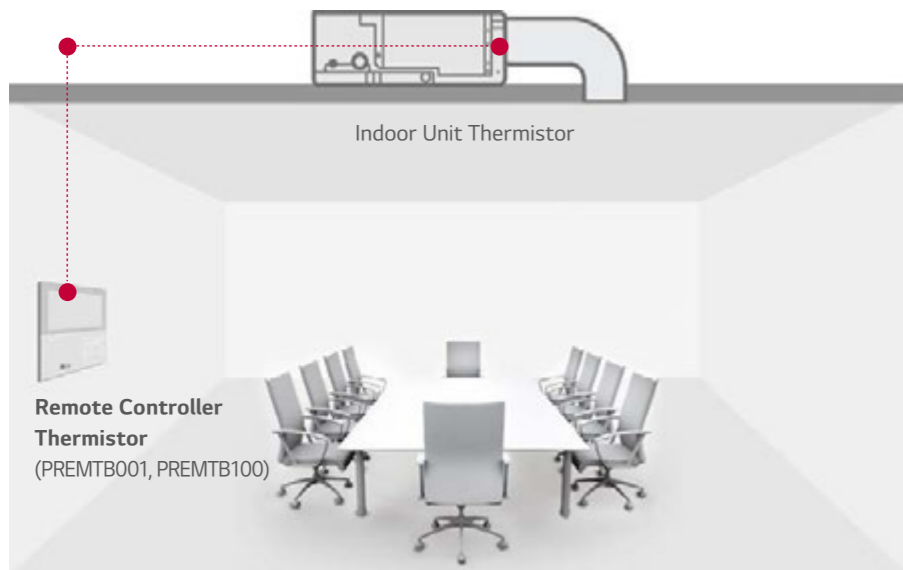

Compares temperatures sensed from different positions, and automatically selects the optimum temperature for users

## Operation for Multiple Rooms

Using a spiral duct (Embedded or flexible type) and stream chamber, it is possible to operate cooling / heating for several rooms simultaneously. Also, zone control is available with zone controller accessory (ABZCA)

### Zone control features

- Controls different zones (up to 4 zones) by external thermostat (AC 24V)
- Maintain proper air volume of each zone
- Auto variation of dampers
- Auto control of fan speed and On / Off operation

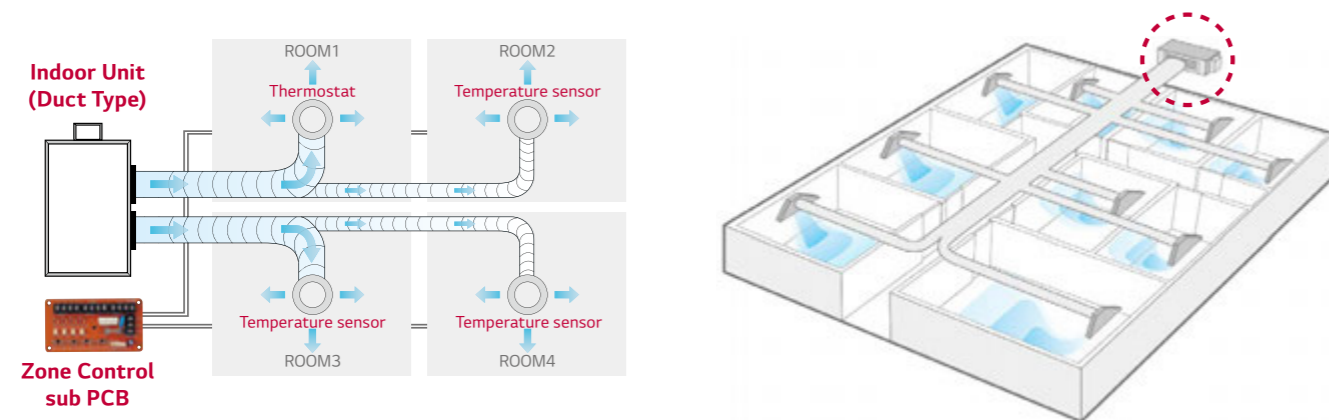

## Minimized Height

New high static ducts provide ideal solution for installation in limited space.

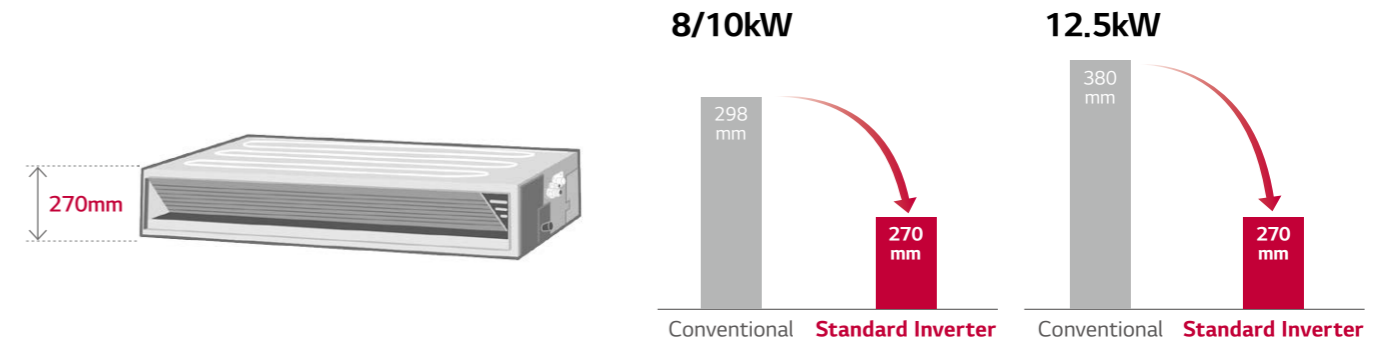

## Wide Operation Range

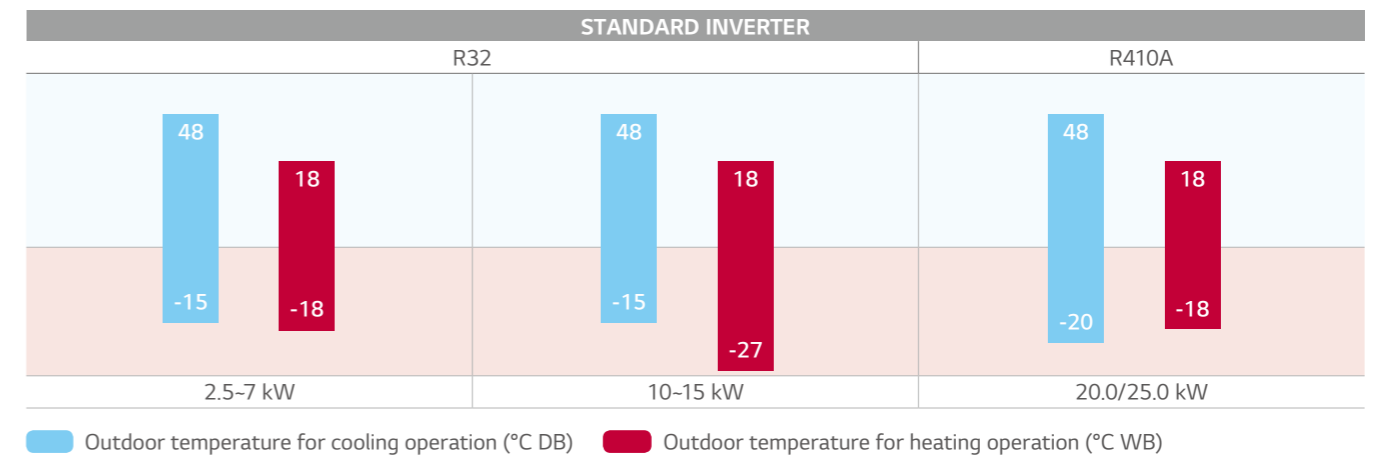

## Easy Service & Maintenance

Users are not required to disassemble the whole panel for maintenance; since panel is divided into 2 components; one for heat exchanger and the other for fan/motor. The user can easily detach and re-attach the filter in the available limited space.

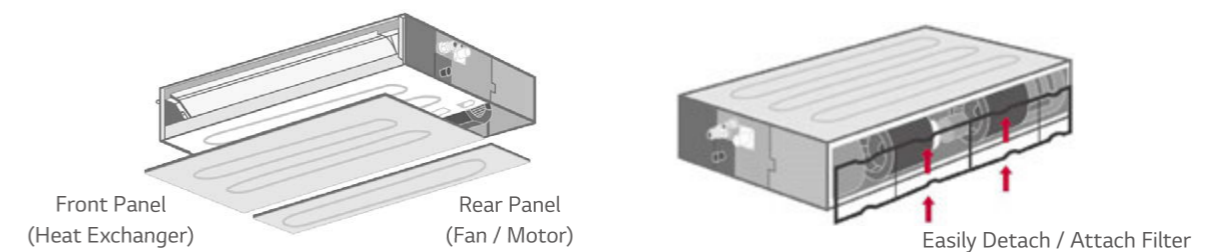

# CEILING CONCEALED DUCT (LOW STATIC PRESSURE)

## Quiet Operation

The noise level of low static ducts have been reduced, even though ESP has been increased.

Sound Pressure (High / Medium / Low)	dB (A)	CL09R N20	CL12R N20	CL18R N20	CL24R N30
		31 / 28 / 27	31 / 28 / 27	36 / 34 / 31	39 / 35 / 32

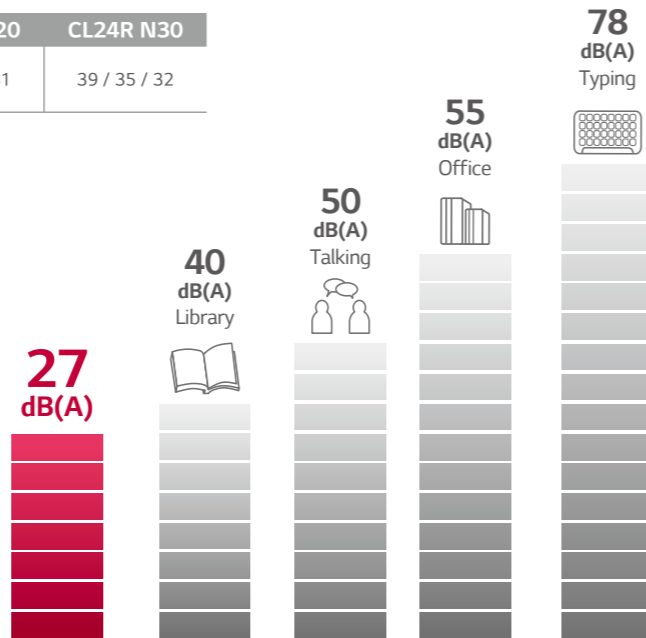

## Flexible Installation

Standard Inverter low static duct allows the air intake at the rear or bottom under installation condition.

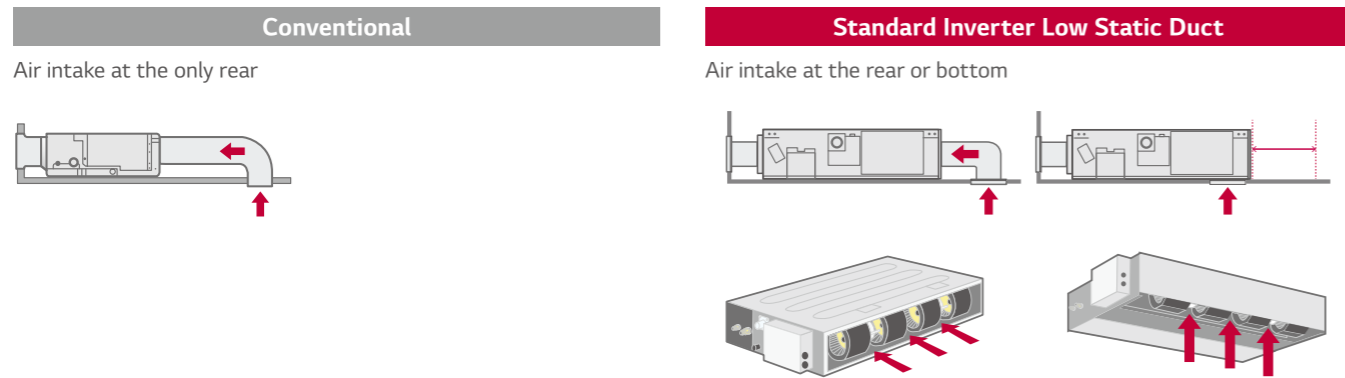

# CEILING CONCEALED DUCT



## STANDARD INVERTER (R32)

### HIGH STATIC PRESSURE - CM18R / CM24R / UM30R



LG participates in the ECP programme for EUROVENT AC program. Check ongoing validity of certification : [www.eurovent-certification.com](http://www.eurovent-certification.com)

UU18WR

UU24WR  
UU30WR



INDOOR			CM18R.N10	CM24R.N10	UM30R.N10*
Capacity	Cooling	Min / Nom / Max	1.8 / 5.0 / 6.0	2.8 / 6.8 / 7.8	3.2 / 7.8 / 8.8
	Heating	Min / Nom / Max	2.2 / 6.0 / 7.2	3.2 / 7.5 / 8.3	3.6 / 9.0 / 9.9
Low Temperature Capacity	Heating -7°C	Max	5.4	7.2	8.1
Power Input (Set)	Cooling	Nom	1.46	2.03	2.31
	Heating	Nom	1.60	2.20	2.62
Power Input (Indoor)		Min / Max (ESP 2.5mmAq)	50 / 80	50 / 90	90 / 150
		Min / Max (ESP 8.0mmAq)	90 / 160	100 / 180	160 / 240
Running Current	Cooling / Heating	Nom	6.5 / 7.1	9.0 / 9.8	10.1 / 10.7
Power Supply		Ø / V / Hz	1 / 220-240 / 50	1 / 220-240 / 50	1 / 220-240 / 50
EER			3.42	3.35	3.37
COP			3.74	3.40	3.44
SEER			6.30	6.81	6.20
SCOP			4.15	4.01	4.00
Pdesign (@-10°C)			4.1	5.4	6.3
Seasonal Energy Label	Cooling / Heating		A++ / A+	A+ / A+	A++ / A+
Annual Energy Consumption	Cooling / Heating		278 / 1,383	350 / 1,890	440 / 2,205
Piping Connection	Liquid		Ø 6.35 (1/4)	Ø 9.52 (3/8)	Ø 9.52 (3/8)
	Gas		Ø 2.7 (1/2)	Ø 15.88 (5/8)	Ø 15.88 (5/8)
	Drain	O.D. / I.D.	32.0 / 25.0	32.0 / 25.0	32.0 / 25.0
Air Flow Rate	High / Medium / Low		16.5 / 14.5 / 13.0	18.0 / 16.5 / 14.5	22.0 / 20.0 / 18.0
Sound Pressure	Cooling	High / Medium / Low	34 / 32 / 30	35 / 34 / 32	37 / 35 / 34
	Cooling	Max	59	60	62
Dehumidification Rate			1.5	2.5	2.8
Dimensions	Body	W x H x D	900 x 270 x 700	900 x 270 x 700	900 x 270 x 700
Net Weight	Body		26.5	26.5	25.3
External Static Pressure		Min / Max	2.5 / 15 (25 / 147)	2.5 / 15 (25 / 147)	2.5 / 15 (25 / 147)

OUTDOOR			UU18WR.U20	UU24WR.U40	UU30WR.U40*
Compressor	Type		Twin Rotary	Twin Rotary	Twin Rotary
Airflow Rate	Nom	m³/min	50	58	58
Sound Pressure	Cooling	Nom	47	48	48
	Heating	Nom	52	52	52
Sound Power	Cooling	Max	63	67	68
Dimensions	W x H x D		870 x 650 x 330	950 x 834 x 330	950 x 834 x 330
Net Weight		kg	44.8	56.1	58.0
	Type		R32	R32	R32
Refrigerant	Charge	g	1,100	1,600	1,900
	Additional Charge (after 7.5m)	g/m	20	35	35
	GWP		675	675	675
	TCO <sub>2</sub> eq		0.74	1.08	1.28
Operation Range (Outdoor)	Cooling	Min / Max	-15 / 48	-15 / 48	-15 / 48
	Heating	Min / Max	-18 / 18	-18 / 18	-18 / 18
Power Supply		Ø / V / Hz	1 / 220-240 / 50	1 / 220-240 / 50	1 / 220-240 / 50
Power Supply Cable		No. x mm²	3C x 2.5	3C x 2.5	3C x 2.5
Transmission Cable		No. x mm²	4C x 0.75	4C x 0.75	4C x 0.75
Circuit Breaker		A	20	25	25
Piping Length Total		m	5 / 30	5 / 50	5 / 50
Piping Elevation Difference	IDU - ODU	Max	30	30	30
Piping Connection	Liquid		Ø 6.35 (1/4)	Ø 9.52 (3/8)	Ø 9.52 (3/8)
	Gas		Ø 12.7 (1/2)	Ø 15.88 (5/8)	Ø 15.88 (5/8)

\* Available from April 2019.

※ For our policy of continuous product improvement, specification, design and features are subject to change without prior notice.

Note : 1. Due to our policy of innovation some specifications may be changed without notification.

2. Definition of Power Input Nominal conditions – Performance tested under EN14511

3. Capacities are based on the following conditions : Cooling : - Indoor Temperature 27°C DB / 19°C WB - Outdoor Temperature 35°C DB / 24°C WB  
Heating : - Indoor Temperature 20°C DB / 15°C WB - Outdoor Temperature 7°C DB / 6°C WB

4. Annual energy consumption : based on average use of 350 running hours in cooling and 1,400 hours in heating per year at seasonal condition

5. This product contains fluorinated greenhouse gases (R32)

# CEILING CONCEALED DUCT



## STANDARD INVERTER (R32)

**HIGH STATIC PRESSURE**  
- UM36R / UM42R / UM48R / UM60R

**UU36WR / UU42WR**  
**UU48WR / UU60WR**



LG participates in the ECP programme for EUROVENT AC program.  
Check ongoing validity of certification  
: www.eurovent-certification.com

INDOOR			UM36R.N20	UM42R.N20	UM48R.N30	UM60R.N30
Capacity	Cooling	Min / Nom / Max	4.5 / 9.5 / 13.0	5.1 / 12.0 / 14.5	5.5 / 13.4 / 16.0	5.9 / 15.0 / 16.3
	Heating	Min / Nom / Max	5.0 / 10.8 / 13.7	5.5 / 13.5 / 16.5	6.1 / 15.5 / 18.0	6.8 / 16.8 / 18.7
Low Temperature Capacity	Heating -7°C	Max	10.0	12.5	14.8	15.2
Power Input (Set)	Cooling	Nom	2.43	3.45	4.00	4.75
	Heating	Nom	2.85	3.65	4.40	4.80
Power Input (Indoor)		Min / Max (ESP 5.0mmAq)	120 / 210	140 / 260	100 / 220	270 / 290
		Min / Max (ESP 15.0mmAq)	200 / 360	230 / 380	220 / 340	300 / 430
Running Current	Cooling / Heating	Nom	10.6 / 12.4	15.0 / 15.9	17.4 / 19.1	20.7 / 20.9
Power Supply		Ø / V / Hz	1 / 220-240 / 50	1 / 220-240 / 50	1 / 220-240 / 50	1 / 220-240 / 50
EER			3.91	3.48	3.35	3.16
COP			3.79	3.70	3.52	3.50
SEER			5.62	5.50	5.51	5.45
SCOP			4.04	4.00	3.96	3.92
Pdesign (@-10°C)			8.05	8.05	9.3	9.3
Seasonal Energy Label	Cooling / Heating		A+ / A+	A / A+	-	-
Annual Energy Consumption	Cooling / Heating		594 / 2,800	764 / 2,800	1,459 / 3,288	1,651 / 3,321
Piping Connection	Liquid		Ø 9.52 (3/8)	Ø 9.52 (3/8)	Ø 9.52 (3/8)	Ø 9.52 (3/8)
	Gas		Ø 15.88 (5/8)	Ø 15.88 (5/8)	Ø 15.88 (5/8)	Ø 15.88 (5/8)
	Drain	O.D. / I.D.	32 / 25	32 / 25	32 / 25	32 / 25
Air Flow Rate		High / Medium / Low	32.0 / 28.0 / 24.0	38.0 / 33.0 / 28.0	40.0 / 34.0 / 28.0	50.0 / 45.0 / 40.0
Sound Pressure	Cooling	High / Medium / Low	36 / 34 / 33	38 / 36 / 34	40 / 38 / 36	42 / 40 / 38
Sound Power	Cooling	Max	60	62	65	66
Dehumidification Rate			2.6	3.6	4.5	5.0
Dimensions	Body	W x H x D	1,250 x 270 x 700	1,250 x 270 x 700	1,250 x 360 x 700	1,250 x 360 x 700
Net Weight	Body		38.5	38.5	43.5	43.5
External Static Pressure		Min / Max	4 / 15 (39 / 147)	5 / 15 (49 / 147)	5 / 15 (49 / 147)	5 / 15 (49 / 147)

OUTDOOR			UU36WR.U30	UU42WR.U30	UU48WR.U30	UU60WR.U30
Compressor	Type		R-Scroll	R-Scroll	R-Scroll	R-Scroll
Airflow Rate	Nom		110	110	110	110
Sound Pressure	Cooling	Nom	52	52	52	52
	Heating	Nom	54	54	54	54
Sound Power	Cooling	Max	66	67	68	68
Dimensions	W x H x D		950 x 1,380 x 330	950 x 1,380 x 330	950 x 1,380 x 330	950 x 1,380 x 330
Net Weight			87.5	87.5	87.5	87.5
Refrigerant	Type		R32	R32	R32	R32
	Charge		3,000	3,000	3,000	3,000
	Additional Charge (after 7.5m)		40	40	40	40
	GWP		675	675	675	675
	TCO <sub>2</sub> eq		2.03	2.03	2.03	2.03
Operation Range (Outdoor)	Cooling	Min / Max	-15 / 48	-15 / 48	-15 / 48	-15 / 48
	Heating	Min / Max	-27 / 18	-27 / 18	-27 / 18	-27 / 18
Power Supply		Ø / V / Hz	1 / 220-240 / 50	1 / 220-240 / 50	1 / 220-240 / 50	1 / 220-240 / 50
Power Supply Cable		No. x mm <sup>2</sup>	3C x 6.0	3C x 6.0	3C x 6.0	3C x 6.0
Transmission Cable		No. x mm <sup>2</sup>	4C x 0.75	4C x 0.75	4C x 0.75	4C x 0.75
Circuit Breaker		A	40	40	40	40
Piping Length Total		Min / Max	5 / 85	5 / 85	5 / 85	5 / 85
Piping Elevation Difference	IDU - ODU	Max	30	30	30	30
Piping Connection	Liquid		Ø 9.52 (3/8)	Ø 9.52 (3/8)	Ø 9.52 (3/8)	Ø 9.52 (3/8)
	Gas		Ø 15.88 (5/8)	Ø 15.88 (5/8)	Ø 15.88 (5/8)	Ø 15.88 (5/8)

※ For our policy of continuous product improvement, specification, design and features are subject to change without prior notice.

Note: 1. Due to our policy of innovation some specifications may be changed without notification.

2. Definition of Power Input Nominal conditions – Performance tested under EN14511

3. Capacities are based on the following conditions : Cooling : - Indoor Temperature 27°C DB / 19°C WB - Outdoor Temperature 35°C DB / 24°C WB  
Heating : - Indoor Temperature 20°C DB / 15°C WB - Outdoor Temperature 7°C DB / 6°C WB

4. Annual energy consumption : based on average use of 350 running hours in cooling and 1,400 hours in heating per year at seasonal condition

5. This product contains fluorinated greenhouse gases (R32)

## STANDARD INVERTER (R32)

**HIGH STATIC PRESSURE**  
- UM36R / UM42R / UM48R / UM60R

**UU37WR / UU43WR**  
**UU49WR / UU61WR**



LG participates in the ECP programme for EUROVENT AC program.  
Check ongoing validity of certification  
: www.eurovent-certification.com

INDOOR			UM36R.N20	UM42R.N20	UM48R.N30	UM60R.N30
Capacity	Cooling	Min / Nom / Max	4.5 / 9.5 / 13.0	5.1 / 12.0 / 14.5	5.5 / 13.4 / 16.0	5.9 / 15.0 / 16.3
	Heating	Min / Nom / Max	5.0 / 10.8 / 13.7	5.5 / 13.5 / 16.5	6.1 / 15.5 / 18.0	6.8 / 16.8 / 18.7
Low Temperature Capacity	Heating -7°C	Max	10.0	12.5	14.8	15.2
Power Input (Set)	Cooling	Nom	2.43	3.45	4.00	4.75
	Heating	Nom	2.85	3.65	4.40	4.80
Power Input (Indoor)		Min / Max (ESP 5.0mmAq)	120 / 210	140 / 260	100 / 220	270 / 290
		Min / Max (ESP 15.0mmAq)	200 / 360	230 / 380	220 / 340	300 / 430
Running Current	Cooling / Heating	Nom	3.5 / 4.1	5.0 / 5.3	5.8 / 6.4	6.9 / 6.9
Power Supply		Ø / V / Hz	1 / 220-240 / 50	1 / 220-240 / 50	1 / 220-240 / 50	1 / 220-240 / 50
EER			3.91	3.48	3.35	3.16
COP			3.79	3.70	3.52	3.50
SEER			5.60	5.50	5.51	5.45
SCOP			4.00	4.00	3.96	3.92
Pdesign (@-10°C)			8.05	8.05	9.3	9.3
Seasonal Energy Label	Cooling / Heating		A+ / A+	A / A+	-	-
Annual Energy Consumption	Cooling / Heating		594 / 2,800	764 / 2,800	1,459 / 3,288	1,651 / 3,321
Piping Connection	Liquid		Ø 9.52 (3/8)	Ø 9.52 (3/8)	Ø 9.52 (3/8)	Ø 9.52 (3/8)
	Gas		Ø 15.88 (5/8)	Ø 15.88 (5/8)	Ø 15.88 (5/8)	Ø 15.88 (5/8)
	Drain	O.D. / I.D.	32 / 25	32 / 25	32 / 25	32 / 25
Air Flow Rate		High / Medium / Low	32.0 / 28.0 / 24.0	38.0 / 33.0 / 28.0	40.0 / 34.0 / 28.0	50.0 / 45.0 / 40.0
Sound Pressure	Cooling	High / Medium / Low	36 / 34 / 33	38 / 36 / 34	40 / 38 / 36	42 / 40 / 38
Sound Power	Cooling	Max	60	62	65	66
Dehumidification Rate			2.6	3.6	4.5	5.0
Dimensions	Body	W x H x D	1,250 x 270 x 700	1,250 x 270 x 700	1,250 x 360 x 700	1,250 x 360 x 700
Net Weight	Body		38.5	38.5	43.5	43.5
External Static Pressure		Min / Max	4 / 15 (39 / 147)	5 / 15 (49 / 147)	5 / 15 (49 / 147)	5-15 (49 / 147)

OUTDOOR			UU37WR.U30	UU43WR.U30	UU49WR.U30	UU61WR.U30
Compressor	Type		R-Scroll	R-Scroll	R-Scroll	R-Scroll
Airflow Rate	Nom		110	110	110	110
Sound Pressure	Cooling	Nom	52	52	52	52
	Heating	Nom	54	54	54	54
Sound Power	Cooling	Max	66	67	68	68
Dimensions	W x H x D		950 x 1,380 x 330	950 x 1,380 x 330	950 x 1,380 x 330	950 x 1,380 x 330
Net Weight			87.5	87.5	87.5	87.5
Refrigerant	Type		R32	R32	R32	R32
	Charge		3,000	3,000	3,000	3,000
	Additional Charge (after 7.5m)		40	40	40	40
	GWP		675	675	675	675
	TCO <sub>2</sub> eq		2.03	2.03	2.03	2.03
Operation Range (Outdoor)	Cooling	Min / Max	-15 / 48	-15 / 48	-15 / 48	-15 / 48
	Heating	Min / Max	-27 / 18	-27 / 18	-27 / 18	-27 / 18
Power Supply		Ø / V / Hz	3 / 380-415 / 50	3 / 380-415 / 50	3 / 380-415 / 50	3 / 380-415 / 50
Power Supply Cable		No. x mm <sup>2</sup>	5C x 2.5	5C x 2.5	5C x 2.5	5C x 2.5
Transmission Cable		No. x mm <sup>2</sup>	4C x 0.75	4C x 0.75	4C x 0.75	4C x 0.75
Circuit Breaker		A	20	40	20	20
Piping Length Total		Min / Max	5 / 85	5 / 85	5 / 85	5 / 85
Piping Elevation Difference	IDU - ODU	Max	30	30	30	30
Piping Connection	Liquid		Ø 9.52 (3/8)	Ø 9.52 (3/8)	Ø 9.52 (3/8)	Ø 9.52 (3/8)
	Gas		Ø 15.88 (5/8)	Ø 15.88 (5/8)	Ø 15.88 (5/8)	Ø 15.88 (5/8)

※ For our policy of continuous product improvement, specification, design and features are subject to change without prior notice.

Note: 1. Due to our policy of innovation some specifications may be changed without notification.

2. Definition of Power Input Nominal conditions – Performance tested under EN14511

3. Capacities are based on the following conditions : Cooling : - Indoor Temperature 27°C DB / 19°C WB - Outdoor Temperature 35°C DB / 24°C WB  
Heating : - Indoor Temperature 20°C DB / 15°C WB - Outdoor Temperature 7°C DB / 6°C WB

4. Annual energy consumption : based on average use of 350 running hours in cooling and 1,400 hours in heating per year at seasonal condition

5. This product contains fluorinated greenhouse gases (R32)

# CEILING CONCEALED DUCT



## STANDARD INVERTER (R32)

LOW STATIC PRESSURE  
- CL09R / CL12R / CL18R / CL24R



LG participates in the ECP programme for EUROVENT AC program.  
Check ongoing validity of certification  
: www.eurovent-certification.com



INDOOR				CL09R.N20	CL12R.N20	CL18R.N20	CL24R.N30
Capacity	Cooling	Min / Nom / Max	kW	1.1 / 2.5 / 3.2	1.4 / 3.4 / 3.9	2.0 / 5.0 / 6.0	4.0 / 7.1 / 7.7
	Heating	Min / Nom / Max	kW	1.2 / 3.2 / 3.6	1.6 / 4.0 / 4.7	2.2 / 6.0 / 7.2	2.0 / 7.5 / 8.2
Low Temperature Capacity	Heating -7°C	Max	kW	3.5	4.4	6.7	8.2
				Power Input (Set)	Cooling	Nom	kW
Power Input (Set)	Heating	Nom	kW	0.74	1.00	1.76	2.06
				Power Input (Indoor)	Min / Max (ESP 2.5mmAq)	W	80 / 95
Power Input (Indoor)	Min / Max (ESP 5.0mmAq)	W	W	80 / 100	80 / 100	100 / 140	110 / 160
				Running Current	Cooling / Heating	Nom	A
Power Supply	Ø / V / Hz			1 / 220-240 / 50	1 / 220-240 / 50	1 / 220-240 / 50	1 / 220-240 / 50
EER				3.90	3.42	3.30	3.30
COP				4.30	4.00	3.41	3.65
SEER				6.28	6.28	6.30	6.60
SCOP				4.00	4.00	3.95	4.20
Pdesign (@-10°C)			kW	3.0	3.0	4.1	5.4
Seasonal Energy Label	Cooling / Heating			A++ / A+	A++ / A+	A++ / A	A++ / A+
Annual Energy Consumption	Cooling / Heating		kWh	139 / 1,050	189 / 1,050	278 / 1,453	377 / 1,798
Piping Connection	Liquid		mm (inch)	Ø 6.35 (1/4)	Ø 6.35 (1/4)	Ø 6.35 (1/4)	Ø 9.52 (3/8)
	Gas		mm (inch)	Ø 9.52 (3/8)	Ø 9.52 (3/8)	Ø 12.7 (1/2)	Ø 15.88 (5/8)
	Drain	O.D. / I.D.	mm	32.0 / 25.0	32.0 / 25.0	32.0 / 25.0	32.0 / 25.0
Air Flow Rate	High / Medium / Low		m³/min	10.0 / 8.5 / 7.0	10.0 / 8.5 / 7.0	15.0 / 12.5 / 10.0	20.0 / 16.0 / 12.0
Sound Pressure	Cooling	High / Medium / Low	dBA	31 / 28 / 27	31 / 28 / 27	36 / 34 / 31	39 / 35 / 32
Sound Power	Cooling	Max	dBA	55	55	54	58
Dehumidification Rate			l/h	0.5	1.1	1.6	2.6
Dimensions	Body	W x H x D	mm	900 x 190 x 700	900 x 190 x 700	900 x 190 x 700	1,100 x 190 x 700
Net Weight	Body		kg	24.0	24.0	24.0	27.0
External Static Pressure		Min / Max	mmAq (Pa)	0 / 5 (0 / 49)	0 / 5 (0 / 49)	0 / 5 (0 / 49)	0 / 5 (0 / 49)

OUTDOOR				UU09WR.U0	UU12WR.U0	UU18WR.U20	UU24WR.U40
Compressor	Type			Twin Rotary	Twin Rotary	Twin Rotary	Twin Rotary
Airflow Rate	Nom		m³/min	32	32	50	58
Sound Pressure	Cooling	Nom	dBA	47	49	47	48
	Heating	Nom	dBA	50	52	52	52
Sound Power	Cooling	Max	dBA	65	65	63	67
Dimensions	W x H x D		mm	770 x 545 x 288	770 x 545 x 288	870 x 650 x 330	950 x 834 x 330
Net Weight			kg	33.8	33.8	44.8	56.1
Refrigerant	Type			R32	R32	R32	R32
	Charge		g	900	900	1,100	1,600
	Additional Charge (after 7.5m)		g/m	20	20	20	35
	GWP			675	675	675	675
Operation Range (Outdoor)	Cooling	Min / Max	°C DB	-15 / 48	-15 / 48	-15 / 48	-15 / 48
	Heating	Min / Max	°C WB	-18 / 18	-18 / 18	-18 / 18	-18 / 18
Power Supply	Ø / V / Hz			1 / 220-240 / 50	1 / 220-240 / 50	1 / 220-240 / 50	1 / 220-240 / 50
Power Supply Cable	No. x mm²			3C x 2.5	3C x 2.5	3C x 2.5	3C x 2.5
Transmission Cable	No. x mm²			4C x 0.75	4C x 0.75	4C x 0.75	4C x 0.75
Circuit Breaker			A	15	15	20	25
Piping Length Total		Min / Max	m	5 / 20	5 / 20	5 / 30	5 / 50
Piping Elevation Difference	IDU - ODU	Max	m	10	10	30	30
Piping Connection	Liquid		mm (inch)	Ø 6.35 (1/4)	Ø 6.35 (1/4)	Ø 6.35 (1/4)	Ø 9.52 (3/8)
	Gas		mm (inch)	Ø 9.52 (3/8)	Ø 9.52 (3/8)	Ø 12.7 (1/2)	Ø 15.88 (5/8)

※ For our policy of continuous product improvement, specification, design and features are subject to change without prior notice.

Note : 1. Due to our policy of innovation some specifications may be changed without notification.

2. Definition of Power Input Nominal conditions – Performance tested under EN14511

3. Capacities are based on the following conditions : Cooling : - Indoor Temperature 27°C DB / 19°C WB - Outdoor Temperature 35°C DB / 24°C WB  
Heating : - Indoor Temperature 20°C DB / 15°C WB - Outdoor Temperature 7°C DB / 6°C WB

4. Annual energy consumption : based on average use of 350 running hours in cooling and 1,400 hours in heating per year at seasonal condition

5. This product contains fluorinated greenhouse gases (R32)

## COMPACT INVERTER (R32)

HIGH STATIC PRESSURE  
- CM18R / CM24R / UM30R / UM36R



LG participates in the ECP programme for EUROVENT AC program.  
Check ongoing validity of certification  
: www.eurovent-certification.com



INDOOR				CM18R.N10	CM24R.N10	UM30R.N10	UM36R.N20*
Capacity	Cooling	Min / Nom / Max	kW	1.8 / 5.0 / 5.3	2.7 / 6.8 / 7.4	3.0 / 7.5 / 8.2	4.5 / 9.5 / 13.0
	Heating	Min / Nom / Max	kW	1.7 / 5.2 / 6.0	1.9 / 7.5 / 8.2	2.0 / 8.0 / 8.4	5.0 / 10.8 / 13.7
Low Temperature Capacity	Heating -7°C	Max	kW	3.9	5.7	7.0	8.7
				Power Input (Set)	Cooling	Nom	kW
Power Input (Set)	Heating	Nom	kW	1.58	2.40	2.28	2.93
				Power Input (Indoor)	Min / Max (ESP 2.5mmAq)	W	50 / 80
Power Input (Indoor)	Min / Max (ESP 8.0mmAq)	W	W	90 / 160	100 / 180	160 / 240	200 / 360
				Running Current	Cooling / Heating	Nom	A
Power Supply	Ø / V / Hz			1 / 220-240 / 50	1 / 220-240 / 50	1 / 220-240 / 50	1 / 220-240 / 50
EER				2.99	3.00	3.21	2.84
COP				3.29	3.13	3.51	3.69
SEER				5.60	5.60	5.88	5.90
SCOP				3.80	3.80	3.90	3.90
Pdesign (@-10°C)			kW	2.9	4.0	4.0	5.5
Seasonal Energy Label	Cooling / Heating			A+ / A	A+ / A	A+ / A	A+ / A
Annual Energy Consumption	Cooling / Heating		kWh	313 / 1,066	425 / 1,474	446 / 1,436	563 / 1,974
Piping Connection	Liquid		mm (inch)	Ø 6.35 (1/4)	Ø 9.52 (3/8)	Ø 9.52 (3/8)	Ø 9.52 (3/8)
	Gas		mm (inch)	Ø 12.7 (1/2)	Ø 15.88 (5/8)	Ø 15.88 (5/8)	Ø 15.88 (5/8)
	Drain	O.D. / I.D.	mm	32.0 / 25.0	32.0 / 25.0	32.0 / 25.0	32 / 25
Air Flow Rate	High / Medium / Low		m³/min	16.5 / 14.5 / 13.0	18.0 / 16.5 / 14.5	22.0 / 20.0 / 18.0	32.0 / 28.0 / 24.0
Sound Pressure	Cooling	High / Medium / Low	dBA	34 / 32 / 30	35 / 34 / 32	37 / 35 / 34	36 / 34 / 33
Sound Power	Cooling	Max	dBA	59	60	62	60
Dehumidification Rate			l/h	1.2	2.5	2.8	2.6
Dimensions	Body	W x H x D	mm	900 x 270 x 700	900 x 270 x 700	900 x 270 x 700	1,250 x 270 x 700
Net Weight	Body		kg	26.5	26.5	27.0	38.5
External Static Pressure		Min / Max	mmAq (Pa)	2.5 / 15 (25 / 147)	2.5 / 15 (25 / 147)	2.5 / 15 (25 / 147)	4 / 15 (39 / 147)

OUTDOOR				UU18WCR.U0	UU24WCR.U20	UU30WCR.U20	UU36WCR.U40*
Compressor	Type			Twin Rotary	Twin Rotary	Twin Rotary	Twin Rotary
Airflow Rate	Nom		m³/min	32	50	50	58
Sound Pressure	Cooling	Nom	dBA	49	49	50	48
	Heating	Nom	dBA	52	53	54	52
Sound Power	Cooling	Max	dBA	65	65	67	68
Dimensions	W x H x D		mm	770 x 545 x 288	870 x 650 x 330	870 x 650 x 330	950 x 834 x 330
Net Weight			kg	45.0	45.0	45.0	58.0
Refrigerant	Type			R32	R32	R32	R32
	Charge		g	1,000	1,300	1,300	1,900
	Additional Charge (after 7.5m)		g/m	20	20	20	35
	GWP			675	675	675	675
Operation Range (Outdoor)	Cooling	Min / Max	°C DB	-10 / 48	-10 / 48	-10 / 48	-15 / 48
	Heating	Min / Max	°C WB	-10 / 18	-10 / 18	-10 / 18	-18 / 18
Power Supply	Ø / V / Hz			1 / 220-240 / 50	1 / 220-240 / 50	1 / 220-240 / 50	1 / 220-240 / 50
Power Supply Cable	No. x mm²			3C x 2.5	3C x 2.5	3C x 2.5	3C x 2.5
Transmission Cable	No. x mm²			4C x 0.75	4C x 0.75	4C x 0.75	4C x 0.75
Circuit Breaker			A	15	20	20	25
Piping Length Total		Min / Max	m	5 / 30	5 / 35	5 / 35	5 / 50
Piping Elevation Difference	IDU - ODU	Max	m	30	30	30	30
Piping Connection	Liquid		mm (inch)	Ø 6.35 (1/4)	Ø 9.52 (3/8)	Ø 9.52 (3/8)	Ø 9.52 (3/8)
	Gas		mm (inch)	Ø 12.7 (1/2)	Ø 15.88 (5/8)	Ø 15.88 (5/8)	Ø 15.88 (5/8)

\* Available from April 2019.

※ For our policy of continuous product improvement, specification, design and features are subject to change without prior notice.

Note : 1. Due to our policy of innovation some specifications may be changed without notification.

2. Definition of Power Input Nominal conditions – Performance tested under EN14511

3. Capacities are based on the following conditions : Cooling : - Indoor Temperature 27°C DB / 19°C WB - Outdoor Temperature 35°C DB / 24°C WB  
Heating : - Indoor Temperature 20°C DB / 15°C WB - Outdoor Temperature 7°C DB / 6°C WB

4. Annual energy consumption : based on average use of 350 running hours in cooling and 1,400 hours in heating per year at seasonal condition

5. This product contains fluorinated greenhouse gases (R32)

SINGLE SPLIT SPECIFICATION

# CEILING CONCEALED DUCT



## STANDARD INVERTER (R410A)

HIGH STATIC PRESSURE  
- UB70 / UB85



LG participates in the ECP programme for EUROVENT AC program.  
Check ongoing validity of certification  
: www.eurovent-certification.com



UU70W

UU85W



INDOOR				UB70.N94	UB85.N94
Capacity	Cooling	Min / Nom / Max	kW	7.6 / 19.0 / 20.9	9.2 / 23.0 / 25.3
	Heating	Min / Nom / Max	kW	9.0 / 22.4 / 24.6	10.8 / 27.0 / 29.7
Low Temperature Capacity	Heating -7°C	Max	kW	18.0	24.0
		Nom	kW	6.69	8.19
Power Input (Set)	Cooling	Nom	kW	6.4	8.31
	Heating	Nom	kW	6.4	8.31
Power Input (Indoor)		Min / Max (Nom ESP)	W	550 / 760	610 / 920
Running Current	Cooling / Heating	Nom	A	11.5 / 10.7	13.5 / 13.6
Power Supply			Ø / V / Hz	1 / 220-240 / 50	1 / 220-240 / 50
EER				2.84	2.81
COP				3.50	3.25
SEER				4.60	4.80
SCOP				3.53	3.51
Pdesign (@ -10°C)			kW	13.4	18.5
Seasonal Energy Label	Cooling / Heating			-	-
Annual Energy Consumption	Cooling / Heating		kWh	-	-
Piping Connection	Liquid		mm (inch)	Ø9.52 (3/8)	Ø12.7 (1/2)
	Gas		mm (inch)	Ø25.4 (1/1)	Ø22.2 (7/8)
	Drain	O.D. / I.D.	mm	32 / 25	32 / 25
Air Flow Rate		High / Medium / Low	m³/min	70.0 / 65.0 / 60.0	80.0 / 72.0 / 64.0
Sound Pressure	Cooling	High / Medium / Low	dBA	43 / 41 / 40	43 / 41 / 40
Sound Power	Cooling	Max	dBA	73	75
Dehumidification Rate			l/h	1.81 (4.2)	5.14 (11.9)
Dimensions	Body	W x H x D	mm	1,563 x 460 x 688	1,563 x 460 x 688
Net Weight	Body		kg	90.0	90.0
External Static Pressure		Min / Max	mmAq (Pa)	6 / 25 (60 / 250)	6 / 25 (60 / 250)

OUTDOOR				UU70W.U34	UU85W.U74
Compressor	Type			Hermetically Sealed Scroll	Hermetically Sealed Scroll
Airflow Rate		Nom	m³/min	110	190
Sound Pressure	Cooling	Nom	dBA	55	59
	Heating	Nom	dBA	58	60
Sound Power	Cooling	Max	dBA	75	75
Dimensions	W x H x D		mm	950 x 1,380 x 330	1,090 x 1,625 x 380
Net Weight			kg	110	144.0
Refrigerant	Type			R410A	R410A
	Charge		g	5,200	5,500
	Additional Charge		g/m	70	70
	GWP			2087.5	2087.5
	TCO <sub>2</sub> eq			10.9	11.5
Operation Range (Outdoor)	Cooling	Min / Max	°C DB	-20 / 48	-20 / 48
	Heating	Min / Max	°C WB	-18 / 18	-18 / 18
Power Supply			Ø / V / Hz	3 / 380-415 / 50	3 / 380-415 / 50
Power Supply Cable			No. x mm²	5C x 2.5	5C x 2.5
Transmission Cable			No. x mm²	4C x 1.0	4C x 1.0
Circuit Breaker			A	30	30
Piping Length Total		Min / Max	m	5 / 75	5 / 75
Piping Elevation Difference	IDU - ODU	Max	m	30	30
Piping Connection	Liquid		mm (inch)	Ø9.53 (3/8)	Ø12.7 (1.2)
	Gas		mm (inch)	Ø25.4 (1/1)	Ø22.2 (7/8)

※ For our policy of continuous product improvement, specification, design and features are subject to change without prior notice.

Note: 1. Due to our policy of innovation some specifications may be changed without notification.

2. Definition of Power Input Nominal conditions - Performance tested under EN14511

3. Capacities are based on the following conditions : Cooling : - Indoor Temperature 27°C DB / 19°C WB - Outdoor Temperature 35°C DB / 24°C WB  
Heating : - Indoor Temperature 20°C DB / 15°C WB - Outdoor Temperature 7°C DB / 6°C WB

4. Annual energy consumption : based on average use of 350 running hours in cooling and 1,400 hours in heating per year at seasonal condition

5. This product contains fluorinated greenhouse gases (R410A)

# CEILING & FLOOR CONVERTIBLE CEILING SUSPENDED UNIT

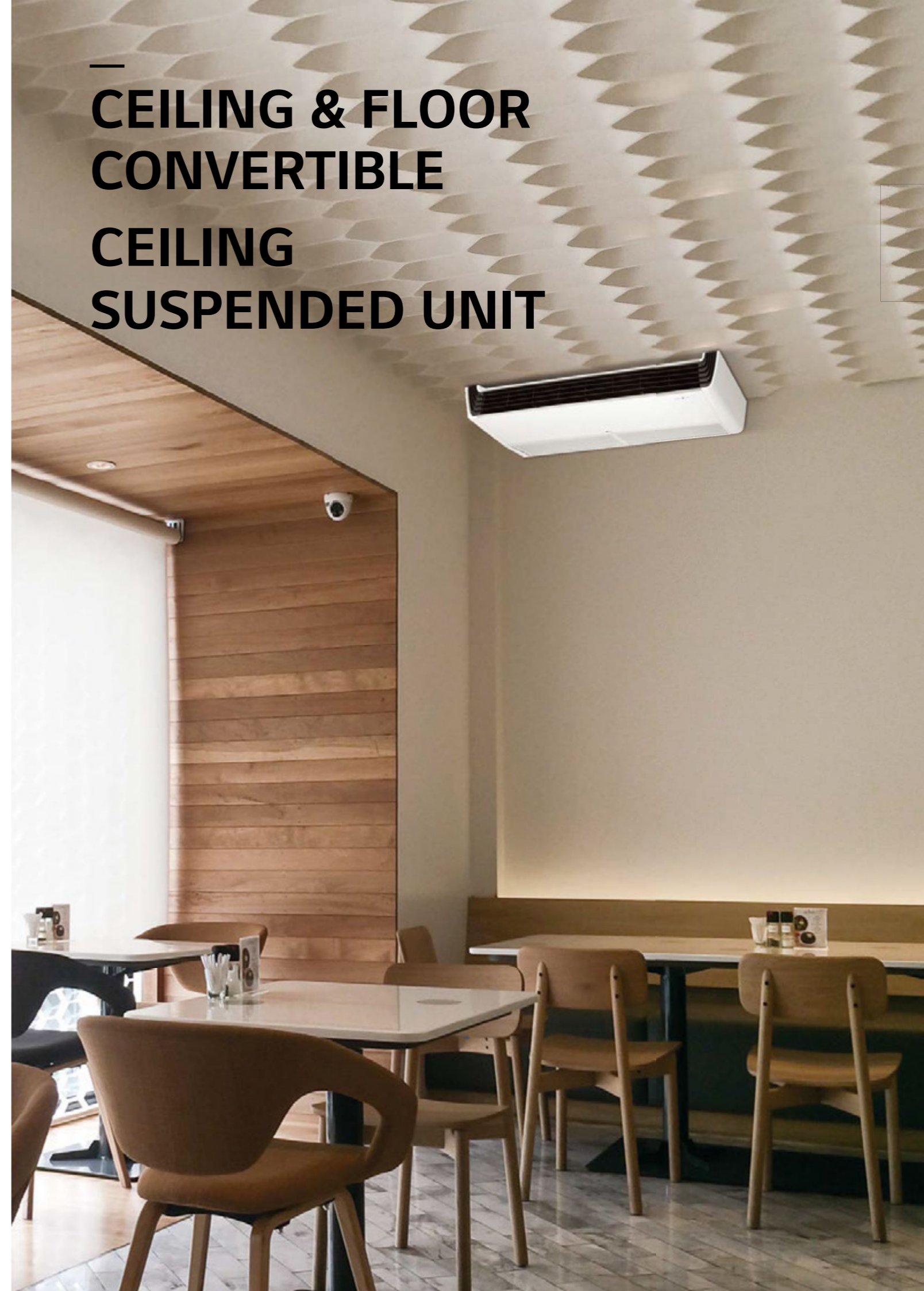



# CEILING & FLOOR CONVERTIBLE

## Flexible Installation

The ceiling and floor models can be installed either on the ceiling or on the floor, thus saving on space while being installed in commercial premises.

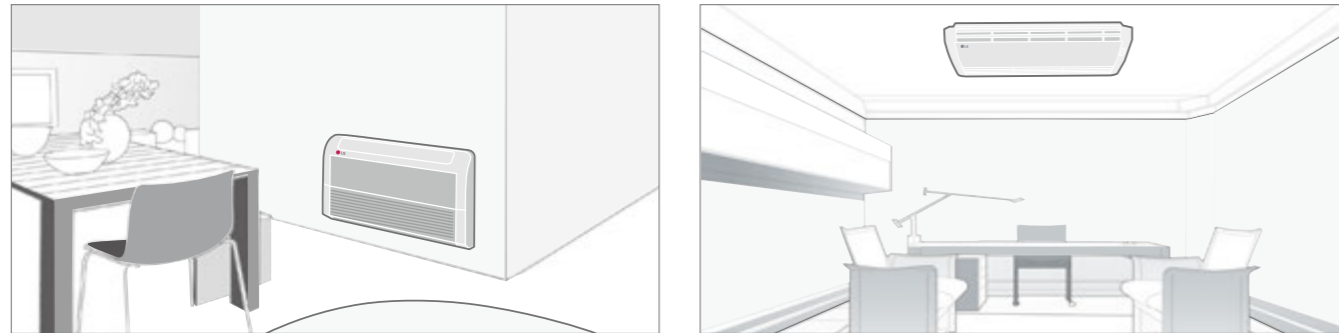

\* Ceiling & Floor : CV09 NE2 / CV12 NE2

## Airflow Direction Control

Vertical airflow direction can be adjusted using the remote controller, while horizontal airflow direction can be adjusted manually.

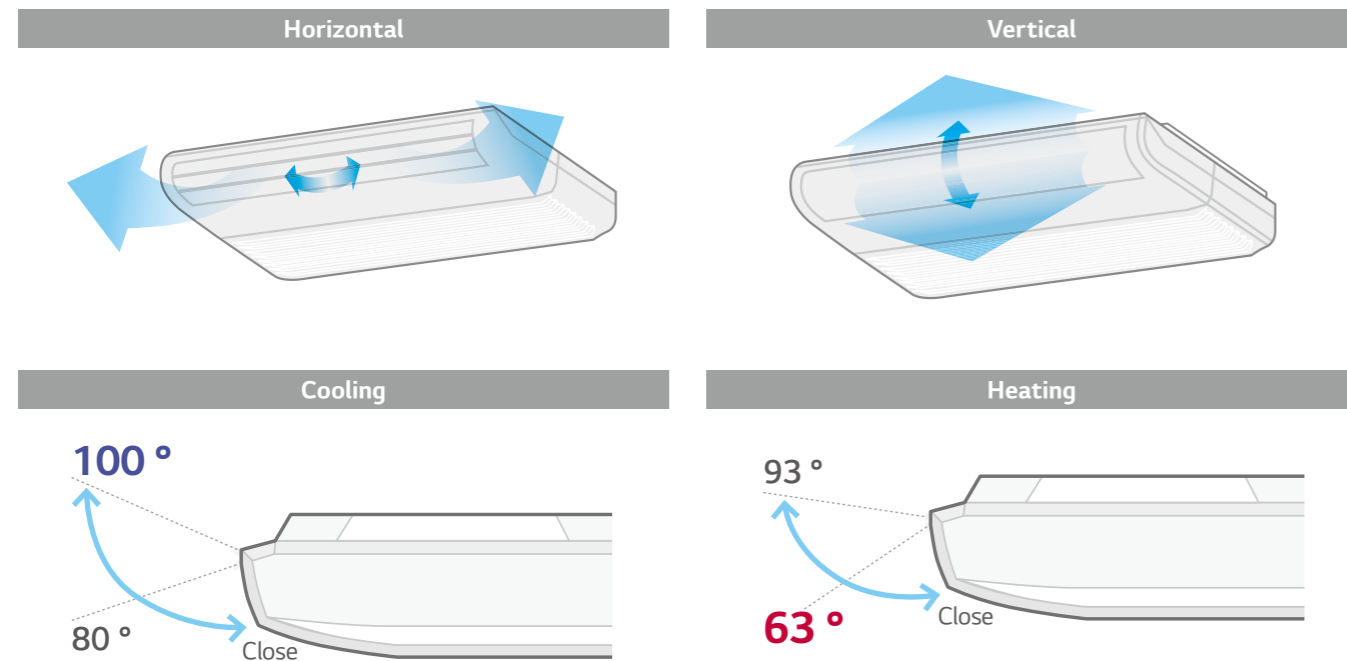

# CEILING SUSPENDED UNIT

## Differentiated Design

With its stunning V-shaped design and black vane, LG's new ceiling-suspended air conditioner portrays elegance and sophistication appropriate for any space. This attractive aesthetics of the air conditioner qualified it for the iF Design Award.



## Powerful Cooling & Heating

The new LG Ceiling Suspended Unit is remarkably efficient for using in large areas due to its powerful cooling and heating operation. The powerful air speed and high volume features enhance the flow of air to reach up to 15m away from the air conditioner.



With enlarged outlet space, optimized the Air flow Path and improved Heat Exchanger's performance

### • Outlet Space

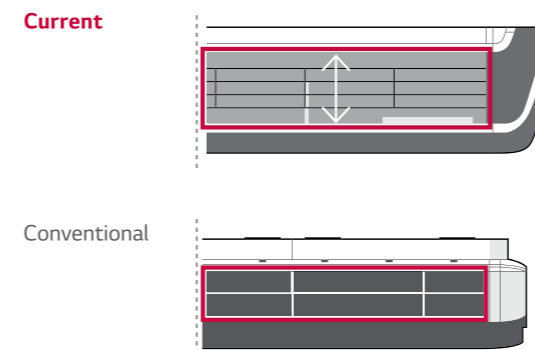

115% ENLARGED

### • Optimized the Air flow Path

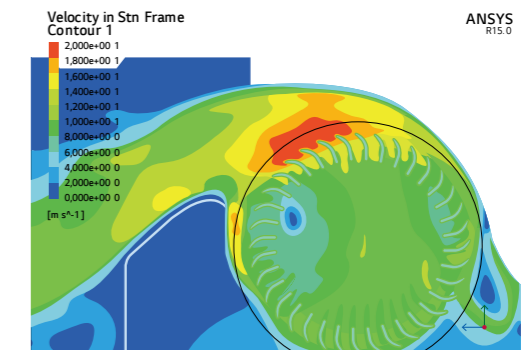

105% IMPROVED

# CEILING SUSPENDED UNIT

## One Touch & 2 Piece Filter

Easy IN/OUT filter structure in addition to an easy-to-use two-piece filter, which slides out for easy cleaning and maintenance.

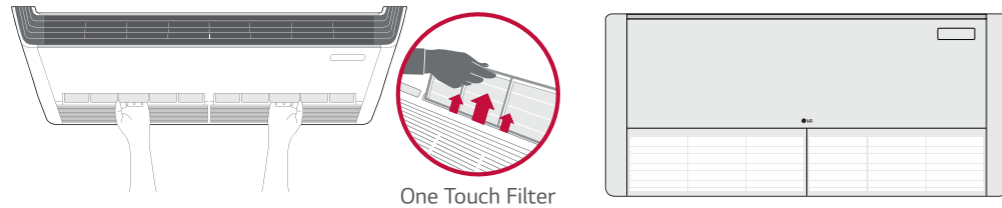

## Two Thermistors Control

Users can purchase an optional control panel that includes a second thermistor that allows checking of temperature from multiple locations.

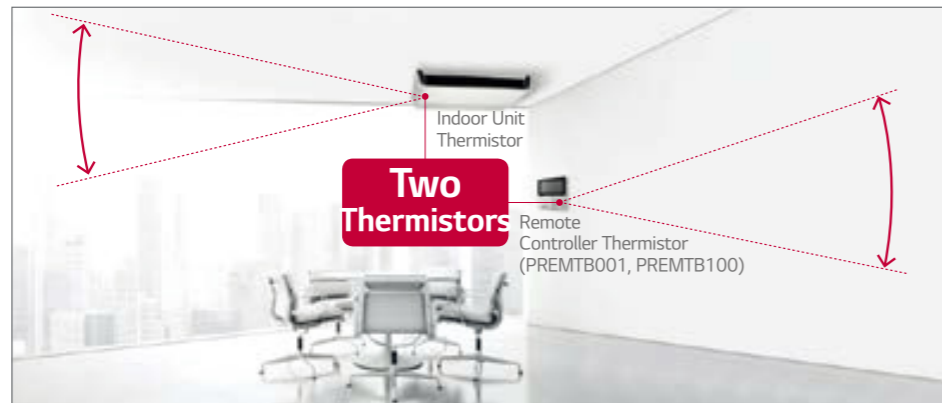

## Easy installation

Installation speed and ease is improved by reducing the total number of screws used and placing the screws on the easily accessible front panel.

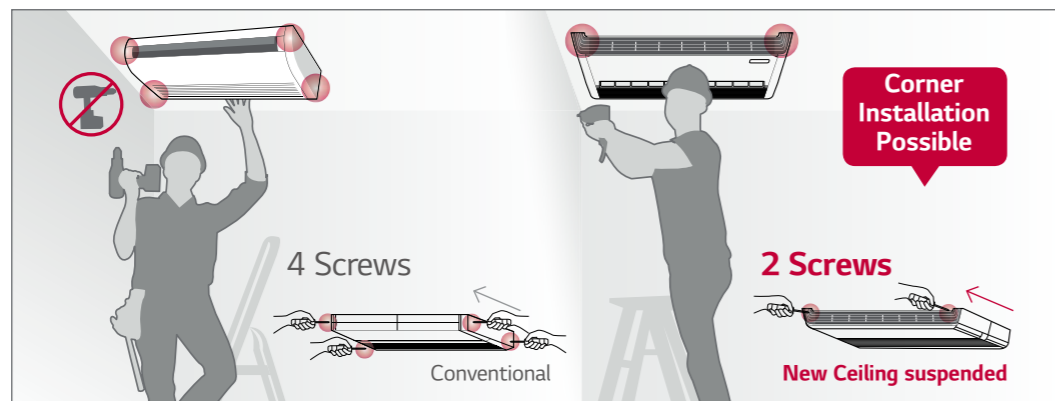

# CEILING SUSPENDED UNIT



## STANDARD INVERTER (R32)

UV18R / UV24R



LG participates in the ECP programme for EUROVENT AC program. Check ongoing validity of certification : [www.eurovent-certification.com](http://www.eurovent-certification.com)

UU18WR



UU24WR  
UU30WR



INDOOR				UV18R.N10	UV24R.N10	UV30R.N10*
Capacity	Cooling	Min / Nom / Max	kW	1.9 / 5.0 / 6.0	2.8 / 6.8 / 7.5	3.0 / 7.6 / 8.4
	Heating	Min / Nom / Max	kW	2.0 / 5.2 / 6.3	3.0 / 7.5 / 8.3	3.4 / 8.2 / 9.2
Low Temperature Capacity	Heating -7°C	Max	kW	4.6	6.9	7.5
				Power Input (Set)	Cooling	Nom
Power Input (Indoor)	Heating	Nom	kW	1.52	2.20	2.52
				Running Current	Cooling / Heating	Min / Max
Power Supply	Cooling / Heating	Nom	W	6.1 / 6.7	8.7 / 9.8	10.2 / 11.1
				Running Current	Ø / V / Hz	1 / 220-240 / 50
EER	COP	SEER	SCOP	3.62	3.45	3.30
				3.42	3.40	3.25
Pdesign (@-10°C)	Seasonal Energy Label	Cooling / Heating	kW	4.1	5.4	5.8
				Annual Energy Consumption	Cooling / Heating	kWh
Piping Connection	Liquid	Gas	O.D. / I.D.	Ø 6.35 (1/4)	Ø 9.52 (3/8)	Ø 9.52 (3/8)
				Ø 12.7 (1/2)	Ø 15.88 (5/8)	Ø 15.88 (5/8)
Air Flow Rate	Sound Pressure	Cooling	High / Medium / Low	21.5 / 16.0	21.5 / 16.0	21.5 / 16.0
				21.5 / 16.0	21.5 / 16.0	21.5 / 16.0
Sound Power	Dehumidification Rate	Cooling	Max	13.0 / 12.0 / 11.0	16.0 / 15.0 / 14.0	16.0 / 15.0 / 14.0
				42 / 40 / 39	44 / 43 / 41	44 / 43 / 41
Dimensions	Net Weight	Body	W x H x D	55	61	61
				1.9	3.0	3.0
Net Weight	Body	W x H x D	mm	1,200 x 235 x 690	1,200 x 235 x 690	1,200 x 235 x 690
				27.3	28.0	28.0

OUTDOOR				UU18WR.U20	UU24WR.U40	UU30WR.U40*	
Compressor	Type			Twin Rotary	Twin Rotary	Twin Rotary	
Airflow Rate		Nom	m³/min	50	58	58	
Sound Pressure	Cooling	Nom	dBA	47	48	48	
				Heating	Nom	dBA	52
Sound Power	Cooling	Max	dBA	63	67	68	
				Dimensions	W x H x D	mm	870 x 650 x 330
Net Weight	Type	Refrigerant	Charge	44.8	56.1	58.0	
				R32	R32	R32	
Refrigerant	Additional Charge (after 10m)	GWP	TCO <sub>eq</sub>	1,100	1,600	1,900	
				20	35	35	
Operation Range (Outdoor)	Cooling	Min / Max	°C DB	675	675	675	
				0.74	1.08	1.28	
Power Supply	Heating	Min / Max	°C WB	-15 / 48	-15 / 48	-15 / 48	
				-18 / 18	-18 / 18	-18 / 18	
Power Supply Cable	Transmission Cable	Circuit Breaker	Piping Length Total	Ø / V / Hz	1 / 220-240 / 50	1 / 220-240 / 50	1 / 220-240 / 50
				No. x mm²	3C x 2.5	3C x 2.5	3C x 2.5
Piping Elevation Difference	IDU - ODU	Max	m	4C x 0.75	4C x 0.75	4C x 0.75	
				20	25	25	
Piping Connection	Liquid	Gas	mm (inch)	5 / 30	5 / 50	5 / 50	
				30	30	30	
Piping Connection	Liquid	Gas	mm (inch)	Ø 6.35 (1/4)	Ø 9.52 (3/8)	Ø 9.52 (3/8)	
				Ø 12.7 (1/2)	Ø 15.88 (5/8)	Ø 15.88 (5/8)	

\* Available from April 2019.

※ For our policy of continuous product improvement, specification, design and features are subject to change without prior notice.

Note : 1. Due to our policy of innovation some specifications may be changed without notification.

2. Definition of Power Input Nominal conditions – Performance tested under EN14511

3. Capacities are based on the following conditions : Cooling : - Indoor Temperature 27°C DB / 19°C WB - Outdoor Temperature 35°C DB / 24°C WB  
Heating : - Indoor Temperature 20°C DB / 15°C WB - Outdoor Temperature 7°C DB / 6°C WB

4. Annual energy consumption : based on average use of 350 running hours in cooling and 1,400 hours in heating per year at seasonal condition

5. This product contains fluorinated greenhouse gases (R32)

# CEILING SUSPENDED UNIT



## STANDARD INVERTER (R32)

UV36R / UV42R / UV48R / UV60R



UU36WR / UU42WR  
UU48WR / UU60WR



LG participates in the ECP programme for EUROVENT AC program.  
Check ongoing validity of certification  
: www.eurovent-certification.com

INDOOR				UV36R.N20	UV42R.N20	UV48R.N20	UV60R.N20
Capacity	Cooling	Min / Nom / Max	kW	4.5 / 9.5 / 13.0	5.0 / 12.0 / 14.5	5.5 / 13.4 / 16.0	5.7 / 14.4 / 15.7
	Heating	Min / Nom / Max	kW	5.0 / 10.8 / 13.7	5.5 / 13.5 / 16.5	6.1 / 15.5 / 18.0	6.8 / 16.8 / 18.7
Low Temperature Capacity	Heating -7°C	Max	kW	9.4	12.5	14.3	15.2
Power Input (Set)	Cooling	Nom	kW	2.30	3.65	4.15	4.90
	Heating	Nom	kW	2.75	4.00	4.90	5.55
Power Input (Indoor)		Min / Max	W	30 / 180	30 / 180	30 / 180	30 / 180
Running Current	Cooling / Heating	Nom	A	10.0 / 12.0	16.9 / 16.0	18.0 / 21.3	21.3 / 24.1
Power Supply		Ø / V / Hz		1 / 220-240 / 50	1 / 220-240 / 50	1 / 220-240 / 50	1 / 220-240 / 50
EER				4.13	3.28	3.23	2.94
COP				3.93	3.37	3.16	3.03
SEER				5.62	5.5	5.51	5.45
SCOP				4.04	4.0	3.96	3.92
Pdesign (@-10°C)			kW	8.05	8.05	9.3	9.3
Seasonal Energy Label	Cooling / Heating			A+ / A+	A / A+	-	-
Annual Energy Consumption	Cooling / Heating		kWh	594 / 2,800	764 / 2,800	1,459 / 3,288	1,651 / 3,321
Piping Connection	Liquid		mm (inch)	Ø 9.52 (3/8)	Ø 9.52 (3/8)	Ø 9.52 (3/8)	Ø 9.52 (3/8)
	Gas		mm (inch)	Ø 15.88 (5/8)	Ø 15.88 (5/8)	Ø 15.88 (5/8)	Ø 15.88 (5/8)
	Drain	O.D. / I.D.	mm	21.5 / 16.0	21.5 / 16.0	21.5 / 16.0	21.5 / 16.0
Air Flow Rate		High / Medium / Low	m³/min	28.0 / 24.0 / 20.0	28.0 / 24.0 / 20.0	30.0 / 25.0 / 20.0	30.0 / 25.0 / 20.0
Sound Pressure	Cooling	High / Medium / Low	dB(A)	46 / 43 / 40	46 / 43 / 40	48 / 44 / 40	48 / 44 / 40
Sound Power	Cooling	Max	dB(A)	63	63	63	63
Dehumidification Rate			l/h	3.8	5.8	6.3	7.1
Dimensions	Body	W x H x D	mm	1,600 x 690 x 235	1,600 x 690 x 235	1,600 x 690 x 235	1,600 x 690 x 235
Net Weight	Body		kg	36.5	36.5	36.5	36.5

OUTDOOR				UU36WR.U30	UU42WR.U30	UU48WR.U30	UU60WR.U30
Compressor	Type			R-Scroll	R-Scroll	R-Scroll	R-Scroll
Airflow Rate	Nom		m³/min	110	110	110	110
Sound Pressure	Cooling	Nom	dB(A)	52	52	52	52
	Heating	Nom	dB(A)	54	54	54	54
Sound Power	Cooling	Max	dB(A)	66	67	68	68
Dimensions	W x H x D		mm	950 x 1,380 x 330	950 x 1,380 x 330	950 x 1,380 x 330	950 x 1,380 x 330
Net Weight			kg	87.5	87.5	87.5	87.5
Refrigerant	Type			R32	R32	R32	R32
	Charge		g	3,000	3,000	3,000	3,000
	Additional Charge (after 7.5m)		g/m	40	40	40	40
	GWP			675	675	675	675
	TCO <sub>2</sub> eq			2.03	2.03	2.03	2.03
Operation Range (Outdoor)	Cooling	Min / Max	°C DB	-15 / 48	-15 / 48	-15 / 48	-15 / 48
	Heating	Min / Max	°C WB	-27 / 18	-27 / 18	-27 / 18	-27 / 18
Power Supply		Ø / V / Hz		1 / 220-240 / 50	1 / 220-240 / 50	1 / 220-240 / 50	1 / 220-240 / 50
Power Supply Cable		No. x mm²		3C x 6.0	3C x 6.0	3C x 6.0	3C x 6.0
Transmission Cable		No. x mm²		4C x 0.75	4C x 0.75	4C x 0.75	4C x 0.75
Circuit Breaker			A	20	40	40	40
Piping Length Total		Min / Max	m	5 / 85	5 / 85	5 / 85	5 / 85
Piping Elevation Difference	IDU - ODU	Max	m	30	30	30	30
Piping Connection	Liquid		mm (inch)	Ø 9.52 (3/8)	Ø 9.52 (3/8)	Ø 9.52 (3/8)	Ø 9.52 (3/8)
	Gas		mm (inch)	Ø 15.88 (5/8)	Ø 15.88 (5/8)	Ø 15.88 (5/8)	Ø 15.88 (5/8)

※ For our policy of continuous product improvement, specification, design and features are subject to change without prior notice.

- Note : 1. Due to our policy of innovation some specifications may be changed without notification.  
 2. Definition of Power Input Nominal conditions – Performance tested under EN14511  
 3. Capacities are based on the following conditions : Cooling : - Indoor Temperature 27°C DB / 19°C WB - Outdoor Temperature 35°C DB / 24°C WB  
 Heating : - Indoor Temperature 20°C DB / 15°C WB - Outdoor Temperature 7°C DB / 6°C WB  
 4. Annual energy consumption : based on average use of 350 running hours in cooling and 1,400 hours in heating per year at seasonal condition  
 5. This product contains fluorinated greenhouse gases (R32)

## STANDARD INVERTER (R32)

UV36R / UV42R / UV48R / UV60R



LG participates in the ECP programme for EUROVENT AC program.  
Check ongoing validity of certification  
: www.eurovent-certification.com

INDOOR				UV36R.N20	UV42R.N20	UV48R.N20	UV60R.N20
Capacity	Cooling	Min / Nom / Max	kW	4.5 / 9.5 / 13.0	5.0 / 12.0 / 14.5	5.5 / 13.4 / 16.0	5.7 / 14.4 / 15.7
	Heating	Min / Nom / Max	kW	5.0 / 10.8 / 13.7	5.5 / 13.5 / 16.5	6.1 / 15.5 / 18.0	6.8 / 16.8 / 18.7
Low Temperature Capacity	Heating -7°C	Max	kW	9.4	12.5	14.3	15.2
Power Input (Set)	Cooling	Nom	kW	2.30	3.65	4.15	4.90
	Heating	Nom	kW	2.75	4.00	4.90	5.55
Power Input (Indoor)		Min / Max	W	30 / 180	30 / 180	30 / 180	30 / 180
Running Current	Cooling / Heating	Nom	A	3.3 / 4.0	5.6 / 5.3	6.0 / 7.1	7.1 / 8.0
Power Supply		Ø / V / Hz		1 / 220-240 / 50	1 / 220-240 / 50	1 / 220-240 / 50	1 / 220-240 / 50
EER				4.13	3.21	3.11	2.94
COP				3.93	3.37	3.41	3.03
SEER				5.60	5.5	-	5.45
SCOP				4.00	4.0	-	3.92
Pdesign (@-10°C)			kW	8.05	8.05	-	9.3
Seasonal Energy Label	Cooling / Heating			A+ / A+	A / A+	-	-
Annual Energy Consumption	Cooling / Heating		kWh	594 / 2,800	764 / 2,800	1,459 / 3,288	1,651 / 3,321
Piping Connection	Liquid		mm (inch)	Ø 9.52 (3/8)	Ø 9.52 (3/8)	Ø 9.52 (3/8)	Ø 9.52 (3/8)
	Gas		mm (inch)	Ø 15.88 (5/8)	Ø 15.88 (5/8)	Ø 15.88 (5/8)	Ø 15.88 (5/8)
	Drain	O.D. / I.D.	mm	21.5 / 16.0	21.5 / 16.0	21.5 / 16.0	21.5 / 16.0
Air Flow Rate		High / Medium / Low	m³/min	28.0 / 24.0 / 20.0	28.0 / 24.0 / 20.0	30.0 / 25.0 / 20.0	30.0 / 25.0 / 20.0
Sound Pressure	Cooling	High / Medium / Low	dB(A)	46 / 43 / 40	46 / 43 / 40	48 / 44 / 40	48 / 44 / 40
Sound Power	Cooling	Max	dB(A)	63	63	63	63
Dehumidification Rate			l/h	3.8	5.8	6.3	7.1
Dimensions	Body	W x H x D	mm	1,600 x 690 x 235	1,600 x 690 x 235	1,600 x 690 x 235	1,600 x 690 x 235
Net Weight	Body		kg	36.5	36.5	36.5	36.5

OUTDOOR				UU37WR.U30	UU43WR.U30	UU49WR.U30	UU61WR.U30
Compressor	Type			R-Scroll	R-Scroll	R-Scroll	R-Scroll
Airflow Rate	Nom		m³/min	110	110	110	110
Sound Pressure	Cooling	Nom	dB(A)	52	52	52	52
	Heating	Nom	dB(A)	54	54	54	54
Sound Power	Cooling	Max	dB(A)	66	67	68	68
Dimensions	W x H x D		mm	950 x 1,380 x 330	950 x 1,380 x 330	950 x 1,380 x 330	950 x 1,380 x 330
Net Weight			kg	87.5	87.5	87.5	87.5
Refrigerant	Type			R32	R32	R32	R32
	Charge		g	3,000	3,000	3,000	3,000
	Additional Charge (after 7.5m)		g/m	40	40	40	40
	GWP			675	675	675	675
	TCO <sub>2</sub> eq			2.03	2.03	2.03	2.03
Operation Range (Outdoor)	Cooling	Min / Max	°C DB	-15 / 48	-15 / 48	-15 / 48	-15 / 48
	Heating	Min / Max	°C WB	-27 / 18	-27 / 18	-27 / 18	-27 / 18
Power Supply		Ø / V / Hz		3 / 380-415 / 50	3 / 380-415 / 50	3 / 380-415 / 50	3 / 380-415 / 50
Power Supply Cable		No. x mm²		5C x 2.5	5C x 2.5	5C x 2.5	5C x 2.5
Transmission Cable		No. x mm²		4C x 0.75	4C x 0.75	4C x 0.75	4C x 0.75
Circuit Breaker			A	20	40	20	20
Piping Length Total		Min / Max	m	5 / 85	5 / 85	5 / 85	5 / 85
Piping Elevation Difference	IDU - ODU	Max	m	30	30	30	30
Piping Connection	Liquid		mm (inch)	Ø 9.52 (3/8)	Ø 9.52 (3/8)	Ø 9.52 (3/8)	Ø 9.52 (3/8)
	Gas		mm (inch)	Ø 15.88 (5/8)	Ø 15.88 (5/8)	Ø 15.88 (5/8)	Ø 15.88 (5/8)

※ For our policy of continuous product improvement, specification, design and features are subject to change without prior notice.

- Note : 1. Due to our policy of innovation some specifications may be changed without notification.  
 2. Definition of Power Input Nominal conditions – Performance tested under EN14511  
 3. Capacities are based on the following conditions : Cooling : - Indoor Temperature 27°C DB / 19°C WB - Outdoor Temperature 35°C DB / 24°C WB  
 Heating : - Indoor Temperature 20°C DB / 15°C WB - Outdoor Temperature 7°C DB / 6°C WB  
 4. Annual energy consumption : based on average use of 350 running hours in cooling and 1,400 hours in heating per year at seasonal condition  
 5. This product contains fluorinated greenhouse gases (R32)

SINGLE SPLIT SPECIFICATION

# CEILING & FLOOR CONVERTIBLE



## STANDARD INVERTER (R410A)



UU09W / UU12W



LG participates in the ECP programme for EUROVENT AC program.  
Check ongoing validity of certification  
: [www.eurovent-certification.com](http://www.eurovent-certification.com)

INDOOR				CV09.NE2	CV12.NE2
Capacity	Cooling	Min / Nom / Max	kW	1.0 / 2.5 / 2.8	1.3 / 3.3 / 3.6
	Heating	Min / Nom / Max	kW	1.2 / 3.0 / 3.3	1.5 / 3.8 / 4.2
Low Temperature Capacity	Heating -7°C	Max	kW	3.1	3.4
				Power Input (Set)	Cooling
Power Input (Indoor)	Heating	Nom	kW	0.83	1.18
				W	Nom
Running Current	Cooling / Heating	Nom	A	3.26 / 3.61	4.74 / 5.13
Power Supply			Ø / V / Hz	1 / 220-240 / 50	1 / 220-240 / 50
EER				3.33	3.03
COP				3.61	3.22
SEER				5.11	5.31
SCOP				3.81	3.81
Pdesign (@ -10°C)			kW	3.0	3.0
Seasonal Energy Label	Cooling / Heating	(A++ to E Scale)		A / A	A / A
Annual Energy Consumption	Cooling / Heating		kWh	172 / 1,102	218 / 1,102
Piping Connection	Liquid		mm (inch)	Ø6.35 (1/4)	Ø6.35 (1/4)
	Gas		mm (inch)	Ø9.52 (3/8)	Ø9.52 (3/8)
	Drain	O.D. / I.D.	mm	21.5 / 16.0	21.5 / 16.0
Air Flow Rate	High / Medium / Low		m³/min	7.6 / 6.9 / 6.2	9.2 / 7.6 / 6.6
Sound Pressure	Cooling	High / Medium / Low	dBA	38 / 35 / 32	40 / 36 / 31
Sound Power	Cooling	Max	dBA	52	56
Dehumidification Rate			l/h	1.2	1.2
Dimensions	Body	W x H x D	mm	900 x 490 x 200	900 x 490 x 200
Net Weight	Body		kg	13.7	13.7

OUTDOOR				UU09W.ULO	UU12W.ULO
Compressor	Type			Rotary	Rotary
Airflow Rate		Nom	m³/min	32	32
Sound Pressure	Cooling	Nom	dBA	47	47
				Heating	Nom
Sound Power	Cooling	Max	dBA	56	57
Dimensions	W x H x D		mm	770 x 540 x 245	770 x 540 x 245
Net Weight			kg	32.0	32.0
Refrigerant	Type			R410A	R410A
	Charge		g	1,000	1,000
	Additional Charge		g/m	20	20
	GWP			2,087.5	2,087.5
	TCO <sub>2</sub> eq			2.1	2.1
Operation Range (Outdoor)	Cooling	Min / Max	°C DB	-10 / 43	-10 / 43
		Heating	Min / Max	°C WB	-18 / 18
Power Supply			Ø / V / Hz	1 / 220-240 / 50	1 / 220-240 / 50
Power Supply Cable			No. x mm²	3C x 2.5	3C x 2.5
Transmission Cable			No. x mm²	4C x 0.75	4C x 0.75
Circuit Breaker			A	15	15
Piping Length Total		Min / Max	m	5 / 15	5 / 15
Piping Elevation Difference	IDU - ODU	Max	m	10	10
Piping Connection	Liquid		mm (inch)	Ø6.35 (1/4)	Ø6.35 (1/4)
	Gas		mm (inch)	Ø9.52 (3/8)	Ø9.52 (3/8)

※ For our policy of continuous product improvement, specification, design and features are subject to change without prior notice.

Note : 1. Due to our policy of innovation some specifications may be changed without notification.

2. Definition of Power Input Nominal conditions – Performance tested under EN14511

3. Capacities are based on the following conditions : Cooling : - Indoor Temperature 27°C DB / 19°C WB - Outdoor Temperature 35°C DB / 24°C WB  
Heating : - Indoor Temperature 20°C DB / 15°C WB - Outdoor Temperature 7°C DB / 6°C WB

4. Annual energy consumption : based on average use of 350 running hours in cooling and 1,400 hours in heating per year at seasonal condition

5. This product contains fluorinated greenhouse gases (R410A)

# CONSOLE



# CONSOLE

## Optimised Air Flow for Cooling & Heating

During the cooling operation, the vane adjusts upwards to direct the air flow towards the ceiling. When heating, the vane directs the warm air downwards to balance out the room temperature especially towards the floor. It is controlled by wireless remote controller which is included indoor unit product

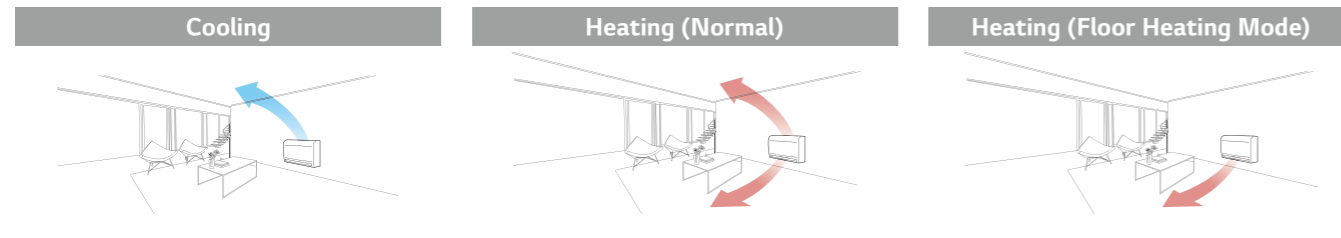

## Quick Floor Heating

Console air conditioners portray high speed and powerful performance. Using the floor heating mode, console air conditioners provides floor heating at a faster pace and helps to reach the desired temperature quickly.

	Company A	Electric Heater	LG	LG Floor Heating Mode
27°C				
15°C				
<b>Lead Time for Heating (13°C - 21°C)</b>	12 minutes 30 seconds	50 minutes	<b>9 minutes 30 seconds</b>	<b>8 minutes 40 seconds</b>

(Test Condition :Target Temp 23°C, Indoor Room : 13°C~, Outdoor Room : 7°C)

## 5-Step Vane Control

There are 5 different stages to control air flow direction.

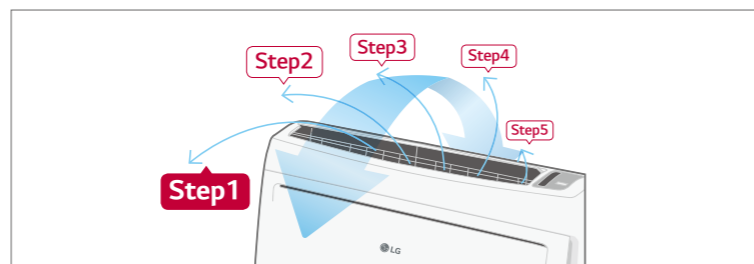

## Easy Installation and Service

### 6 Different Ways to Install Piping

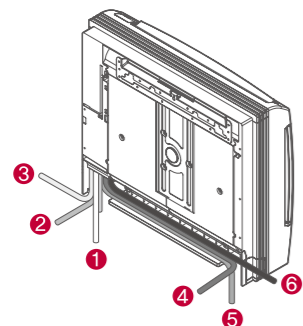

### Easy Slide-type PCB

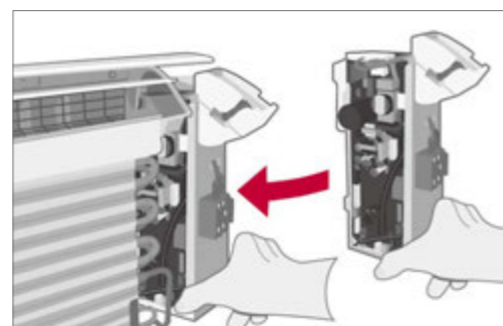

# CONSOLE



## STANDARD INVERTER (R410A)

CQ09  
CQ12  
CQ18



LG participates in the ECP programme for EUROVENT AC program. Check ongoing validity of certification : [www.eurovent-certification.com](http://www.eurovent-certification.com)

UU09W  
UU12W

UU18W



INDOOR		CQ09.NAO	CQ12.NAO	CQ18.NAO	
Capacity	Cooling	Min / Nom / Max	1.3 / 2.6 / 3.4	1.4 / 3.5 / 3.7	2.2 / 5.0 / 5.6
	Heating	Min / Nom / Max	1.4 / 3.1 / 4.2	1.6 / 4.0 / 4.4	2.2 / 4.8 / 5.8
Low Temperature Capacity	Heating -7°C	Max	3.4	3.6	4.9
Power Input (Set)	Cooling	Nom	0.64	1.06	1.55
	Heating	Nom	0.74	1.08	1.50
Power Input (Indoor)		Nom	20	30	40
Running Current	Cooling / Heating	Nom	3.42 / 3.87	5.02 / 5.03	7.0 / 6.9
Power Supply		Ø / V / Hz	1 / 220-240 / 50	1 / 220-240 / 50	1 / 220-240 / 50
EER			3.98	3.30	3.23
COP			4.19	3.70	3.20
SEER			5.11	5.31	6.2
SCOP			3.81	3.81	3.81
Pdesign (@ -10°C)			2.8	3.0	3.8
Seasonal Energy Label	Cooling / Heating (A++ to E Scale)		A / A	A / A	A++ / A
Annual Energy Consumption	Cooling / Heating		172 / 1,032	231 / 1,105	282 / 1,396
Piping Connection	Liquid		Ø6.35 (1/4)	Ø6.35 (1/4)	Ø6.35 (1/4)
	Gas		Ø9.52 (3/8)	Ø9.52 (3/8)	Ø12.7 (1/2)
	Drain	O.D. / I.D.	21.5 / 16.0	21.5 / 16.0	21.5 / 16.0
Air Flow Rate		High / Medium / Low	8.5 / 6.7 / 5.0	9.0 / 6.9 / 5.2	10.1 / 8.6 / 7.2
Sound Pressure	Cooling	High / Medium / Low	38 / 32 / 27	39 / 32 / 27	44 / 39 / 35
Sound Power	Cooling	Max	53	56	60
Dehumidification Rate			1.2	1.4	2.3
Dimensions	Body	W x H x D	700 x 600 x 210	700 x 600 x 210	700 x 600 x 210
Net Weight	Body		14.0	14.0	14.0

OUTDOOR		UU09W.ULO	UU12W.ULO	UU18W.UE4	
Compressor	Type	Rotary	Rotary	Twin Rotary	
Airflow Rate		32	32	50	
Sound Pressure	Cooling	Nom	47	47	
	Heating	Nom	48	48	
Sound Power	Cooling	Max	56	57	
	Heating	Max	57	63	
Dimensions	W x H x D	770 x 540 x 245	770 x 540 x 245	870 x 655 x 320	
Net Weight		32.0	32.0	44.6	
Refrigerant	Type	R410A	R410A	R410A	
	Charge	1,000	1,000	1,300	
	Additional Charge	20	20	20	
	GWP	2,087.5	2,087.5	2,087.5	
	TCO <sub>2</sub> eq	2.1	2.1	2.7	
Operation Range (Outdoor)	Cooling	Min / Max	-10 / 43	-10 / 43	-15 / 48
	Heating	Min / Max	-18 / 18	-18 / 18	-18 / 18
Power Supply		Ø / V / Hz	1 / 220-240 / 50	1 / 220-240 / 50	1 / 220-240 / 50
Power Supply Cable		No. x mm <sup>2</sup>	3C x 2.5	3C x 2.5	3C x 2.5
Transmission Cable		No. x mm <sup>2</sup>	4C x 0.75	4C x 0.75	4C x 0.75
Circuit Breaker		A	15	15	20
Piping Length Total		Min / Max	5 / 15	5 / 15	5 / 30
Piping Elevation Difference	IDU - ODU	Max	10	10	30
Piping Connection	Liquid		Ø6.35 (1/4)	Ø6.35 (1/4)	Ø6.35 (1/4)
	Gas		Ø9.52 (3/8)	Ø9.52 (3/8)	Ø12.7 (1/2)

※ For our policy of continuous product improvement, specification, design and features are subject to change without prior notice.

- Note : 1. Due to our policy of innovation some specifications may be changed without notification.  
 2. Definition of Power Input Nominal conditions – Performance tested under EN14511  
 3. Capacities are based on the following conditions : Cooling : - Indoor Temperature 27°C DB / 19°C WB - Outdoor Temperature 35°C DB / 24°C WB  
 Heating : - Indoor Temperature 20°C DB / 15°C WB - Outdoor Temperature 7°C DB / 6°C WB  
 4. Annual energy consumption : based on average use of 350 running hours in cooling and 1,400 hours in heating per year at seasonal condition  
 5. This product contains fluorinated greenhouse gases (R410A)

# FLOOR STANDING UNIT



SINGLE SPLIT KEY FEATURES

## FLOOR STANDING UNIT

### Stylish Design

The new LG floor standing air conditioner which is Red Dot design award winner 2013, is ideal for modern interiors in your home or office.



reddot design award  
winner 2013

### Quick Response

Offering powerful cooling, the commercial air conditioning system can reach a set temperature in a shorter period of time. Meanwhile, the Power Heating function provides the optimal airflow angle, guaranteeing a faster heating performance.

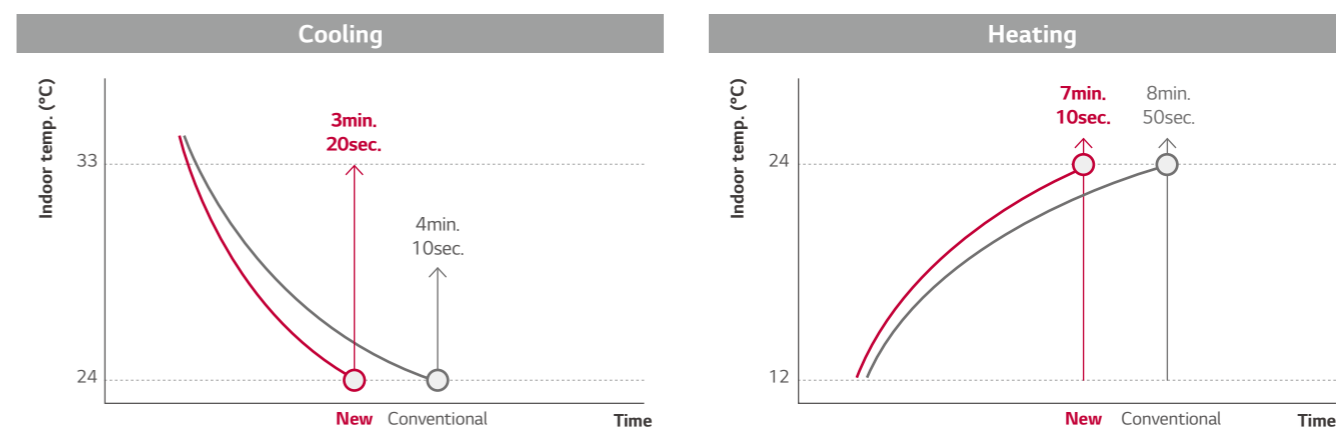

### Powerful Air Flow

The new LG floor standing air conditioner is efficient for using in large areas due to its powerful cooling and heating operation. The powerful air speed and volume means the air flow can reach up to 20m away from the air conditioner.

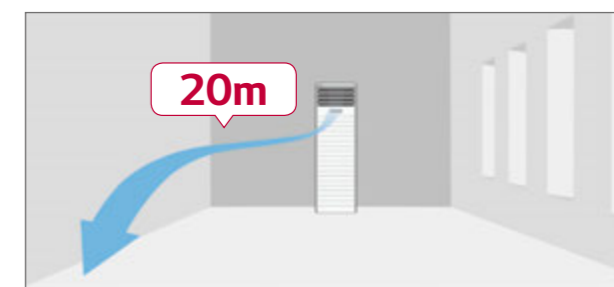

# FLOOR STANDING UNIT



## STANDARD INVERTER (R410A)

### UP48



LG participates in the ECP programme for EUROVENT AC program.  
Check ongoing validity of certification  
: www.eurovent-certification.com

### UU48W



INDOOR				UP48.NT2	
Capacity	Cooling	Min / Nom / Max	kW	6.0 / 13.4 / 15.2	
	Heating	Min / Nom / Max	kW	6.0 / 15.5 / 17.1	
Low Temperature Capacity	Heating -7°C	Max	kW	16.0	
Power Input (Set)	Cooling	Nom	kW	4.2	
	Heating	Nom	kW	4.5	
Power Input (Indoor)		Nom	W	200	
Running Current	Cooling / Heating	Nom	A	18.1 / 19.5	
Power Supply			Ø / V / Hz	1 / 220-240 / 50	
EER				3.21	
COP				3.41	
SEER				5.05	
SCOP				3.51	
Pdesign (@ -10°C)			kW	11.5	
Seasonal Energy Label	Cooling / Heating			-	
Annual Energy Consumption	Cooling / Heating		kWh	-	
Piping Connection	Liquid		mm (inch)	Ø9.52 (3/8)	
	Gas		mm (inch)	Ø15.88 (5/8)	
	Drain	O.D. / I.D.	mm	32 / 25	
Air Flow Rate		High / Medium / Low	m³/min	31 / 27 / 23	
Sound Pressure	Cooling	High / Medium / Low	dBA	52 / 49 / 45	
Sound Power	Cooling	Max	dBA	65	
Dehumidification Rate			l/h	5.0	
Dimensions	Body	W x H x D	mm	590 x 1,840 x 460	
Net Weight	Body		kg	50.0	

OUTDOOR				UU48W.U32	
Compressor	Type			Twin Rotary	
Airflow Rate		Nom	m³/min	110	
Sound Pressure	Cooling	Nom	dBA	52	
	Heating	Nom	dBA	54	
Sound Power	Cooling	Max	dBA	72	
Dimensions	W x H x D		mm	950 x 1,380 x 330	
Net Weight			kg	92.0	
Refrigerant	Type			R410A	
	Charge		g	3,400	
	Additional Charge		g/m	40	
	GWP			2087.5	
	TCO <sub>2</sub> eq			7.1	
Operation Range (Outdoor)	Cooling	Min / Max	°C DB	-15 / 48	
	Heating	Min / Max	°C WB	-18 / 18	
Power Supply			Ø / V / Hz	1 / 220-240 / 50	
Power Supply Cable			No. x mm²	3C x 5.0	
Transmission Cable			No. x mm²	4C x 0.75	
Circuit Breaker			A	40	
Piping Length Total		Min / Max	m	5 / 75	
Piping Elevation Difference	IDU - ODU	Max	m	30	
Piping Connection	Liquid		mm (inch)	Ø9.52 (3/8)	
	Gas		mm (inch)	Ø15.88 (5/8)	

※ For our policy of continuous product improvement, specification, design and features are subject to change without prior notice.

Note : 1. Due to our policy of innovation some specifications may be changed without notification.

2. Definition of Power Input Nominal conditions – Performance tested under EN14511

3. Capacities are based on the following conditions : Cooling : - Indoor Temperature 27°C DB / 19°C WB - Outdoor Temperature 35°C DB / 24°C WB  
Heating : - Indoor Temperature 20°C DB / 15°C WB - Outdoor Temperature 7°C DB / 6°C WB

4. Annual energy consumption : based on average use of 350 running hours in cooling and 1,400 hours in heating per year at seasonal condition

5. This product contains fluorinated greenhouse gases (R410A)

## STANDARD INVERTER (R410A)

### UP49



LG participates in the ECP programme for EUROVENT AC program.  
Check ongoing validity of certification  
: www.eurovent-certification.com

### UU49W



INDOOR				UP49.NT2	
Capacity	Cooling	Min / Nom / Max	kW	6.0 / 13.4 / 15.2	
	Heating	Min / Nom / Max	kW	6.0 / 15.5 / 17.1	
Low Temperature Capacity	Heating -7°C	Max	kW	16.0	
Power Input (Set)	Cooling	Nom	kW	4.2	
	Heating	Nom	kW	4.5	
Power Input (Indoor)		Nom	W	200	
Running Current	Cooling / Heating	Nom	A	5.76 / 6.20	
Power Supply			Ø / V / Hz	1 / 220-240 / 50	
EER				3.21	
COP				3.41	
SEER				5.05	
SCOP				3.51	
Pdesign (@ -10°C)			kW	11.5	
Seasonal Energy Label	Cooling / Heating			-	
Annual Energy Consumption	Cooling / Heating		kWh	-	
Piping Connection	Liquid		mm (inch)	Ø9.52 (3/8)	
	Gas		mm (inch)	Ø15.88 (5/8)	
	Drain	O.D. / I.D.	mm	32 / 25	
Air Flow Rate		High / Medium / Low	m³/min	31 / 27 / 23	
Sound Pressure	Cooling	High / Medium / Low	dBA	52 / 49 / 45	
Sound Power	Cooling	Max	dBA	59	
Dehumidification Rate			l/h	5.0	
Dimensions	Body	W x H x D	mm	590 x 1,840 x 460	
Net Weight	Body		kg	50.0	

OUTDOOR				UU49W.U32	
Compressor	Type			Twin Rotary	
Airflow Rate		Nom	m³/min	110	
Sound Pressure	Cooling	Nom	dBA	52	
	Heating	Nom	dBA	54	
Sound Power	Cooling	Max	dBA	68	
Dimensions	W x H x D		mm	950 x 1,380 x 330	
Net Weight			kg	96.0	
Refrigerant	Type			R410A	
	Charge		g	3,400	
	Additional Charge		g/m	40	
	GWP			2087.5	
	TCO <sub>2</sub> eq			7.1	
Operation Range (Outdoor)	Cooling	Min / Max	°C DB	-15 / 48	
	Heating	Min / Max	°C WB	-18 / 18	
Power Supply			Ø / V / Hz	3 / 380-415 / 50	
Power Supply Cable			No. x mm²	5C x 5.0	
Transmission Cable			No. x mm²	4C x 0.75	
Circuit Breaker			A	20	
Piping Length Total		Min / Max	m	5 / 75	
Piping Elevation Difference	IDU - ODU	Max	m	30	
Piping Connection	Liquid		mm (inch)	Ø9.52 (3/8)	
	Gas		mm (inch)	Ø15.88 (5/8)	

※ For our policy of continuous product improvement, specification, design and features are subject to change without prior notice.

Note : 1. Due to our policy of innovation some specifications may be changed without notification.

2. Definition of Power Input Nominal conditions – Performance tested under EN14511

3. Capacities are based on the following conditions : Cooling : - Indoor Temperature 27°C DB / 19°C WB - Outdoor Temperature 35°C DB / 24°C WB  
Heating : - Indoor Temperature 20°C DB / 15°C WB - Outdoor Temperature 7°C DB / 6°C WB

4. Annual energy consumption : based on average use of 350 running hours in cooling and 1,400 hours in heating per year at seasonal condition

5. This product contains fluorinated greenhouse gases (R410A)

# WALL MOUNTED UNIT



SINGLE SPLIT KEY FEATURES

## WALL MOUNTED UNIT

### Wide Operation Range

Ideal and comprehensive solution for server rooms, machine rooms and kitchens.

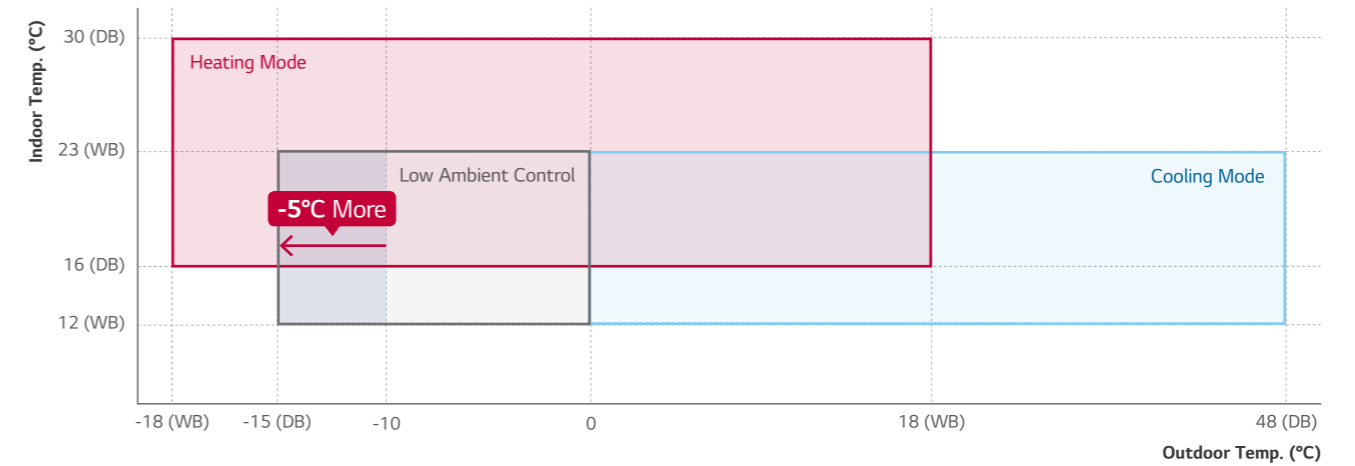

### Easy Installation

#### Detachable Bottom Cover

The bottom cover is detachable when needed, making installation easier. Disassembly or additional support of the unit is unnecessary. Installation can be completed by one individual with LG's patented support tool.

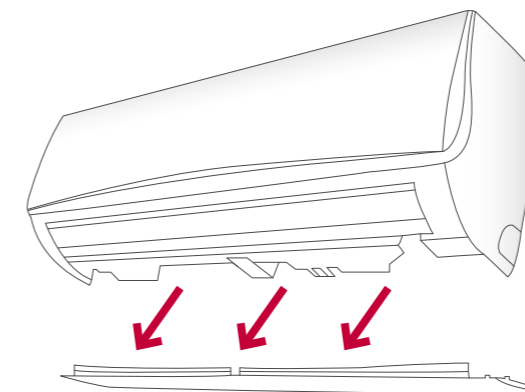

#### Installation Support Clip

A support clip creates adequate space between the wall and the unit for easier installation.

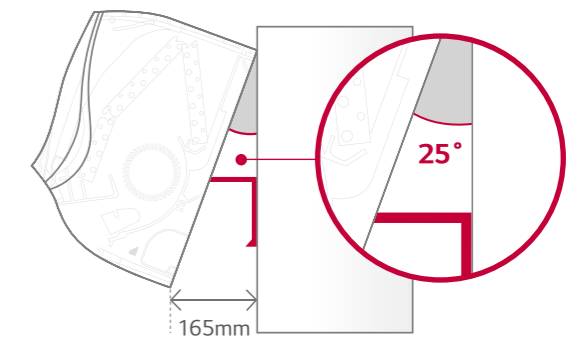



# WALL MOUNTED UNIT

## High Energy Efficiency

New wall mounted units provide good seasonal energy efficiency connected with Standard Inverter outdoor units.

	8.0kW	10kW
SEER	6.1 (A++)	5.4 (A)
SCOP	3.9 (A)	3.8 (A)

## Powerful Cooling & Heating

### 20m Windblast

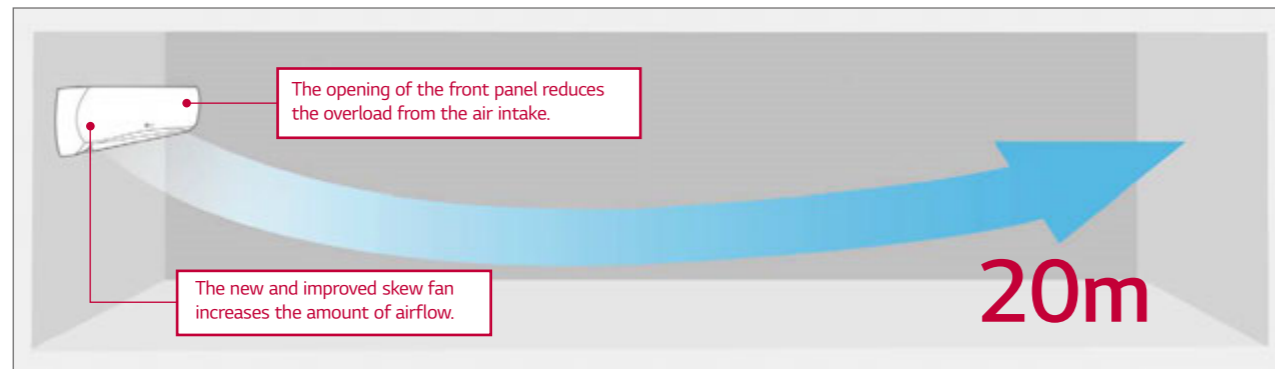

### Optimised Airflow

Direction of horizontal vane can be adjusted from step 1 to step 6 with full auto swing. This function can cool and heat specific areas much faster.

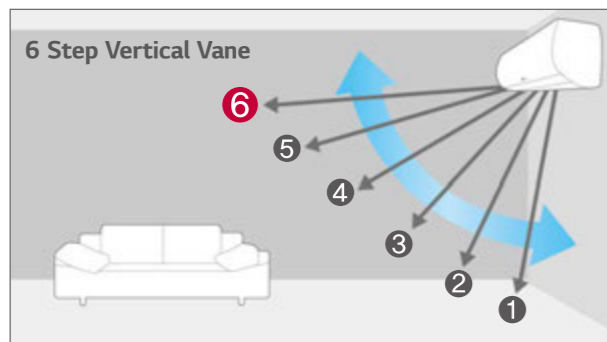

### Quick Cooling & Heating

Jet cooling and heating disperses air evenly at high speed to secure an optimally cooled or heated room in just 3 minutes.



# WALL MOUNTED UNIT



## STANDARD INVERTER (R410A)

### UJ30 / UJ36



LG participates in the ECP programme for EUROVENT AC program. Check ongoing validity of certification : [www.eurovent-certification.com](http://www.eurovent-certification.com)

### UU30W



### UU36W UU37W



INDOOR			UJ30.NV2	UJ36.NV3	UJ36.NV3	
Capacity	Cooling	Min / Nom / Max	kW	3.5 / 7.8 / 8.5	4.0 / 9.5 / 10.5	4.0 / 9.5 / 10.5
	Heating	Min / Nom / Max	kW	4.0 / 8.4 / 9.2	4.4 / 10.5 / 11.5	4.4 / 10.5 / 11.5
Low Temperature Capacity	Heating -7°C	Max	kW	7.5	9.4	9.4
				Power Input (Set)	Cooling	Nom
Power Input (Set)	Heating	Nom	kW	2.46	3.08	3.08
				Nom	W	140
Running Current	Cooling / Heating	Nom	A	10.0 / 10.7	12.1 / 13.4	4.0 / 4.4
Power Supply			Ø / V / Hz	1 / 220-240 / 50	1 / 220-240 / 50	1 / 220-240 / 50
EER				3.41	3.41	3.41
COP				3.41	3.41	3.41
SEER				6.11	5.41	5.41
SCOP				3.91	3.81	3.81
Pdesign (@ -10°C)			kW	6.3	7.6	7.6
Seasonal Energy Label	Cooling / Heating (A++ to E Scale)			A++ / A	A / A	A / A
Annual Energy Consumption	Cooling / Heating		kWh	448 / 2,262	615 / 2,793	615 / 2,793
	Liquid		mm (inch)	Ø9.52 (3/8)	Ø9.52 (3/8)	Ø9.52 (3/8)
Piping Connection	Gas		mm (inch)	Ø15.88 (5/8)	Ø15.88 (5/8)	Ø15.88 (5/8)
	Drain	O.D. / I.D.	mm	21.5 / 16.0	21.5 / 16.0	21.5 / 16.0
Air Flow Rate		High / Medium / Low	m³/min	22.0 / 19.0 / 16.0	27.0 / 24.0 / 20.0	27.0 / 24.0 / 20.0
Sound Pressure	Cooling	High / Medium / Low	dBA	45 / 42 / 40	48 / 45 / 41	48 / 45 / 41
Sound Power	Cooling	Max	dBA	61	63	63
Dehumidification Rate			l/h	3.0	3.4	3.4
Dimensions	Body	W x H x D	mm	1,190 x 346 x 265	1,190 x 346 x 265	1,190 x 346 x 265
Net Weight	Body		kg	15.7	16.0	16.0

OUTDOOR			UU30W.U44	UU36W.U02	UU37W.U02	
Compressor	Type		Twin Rotary	Twin Rotary	Twin Rotary	
Airflow Rate		Nom	m³/min	58	90	90
Sound Pressure	Cooling	Nom	dBA	48	53	53
	Heating	Nom	dBA	52	54	54
Sound Power	Cooling	Max	dBA	68	66	66
	Dimensions	W x H x D	mm	950 x 834 x 330	950 x 1,170 x 330	950 x 1,170 x 330
Net Weight			kg	58.0	81.0	85.0
Refrigerant	Type			R410A	R410A	R410A
	Charge		g	2,000	2,800	2,800
	Additional Charge		g/m	40	40	40
	GWP			2087.5	2087.5	2087.5
	TCO <sub>2</sub> eq			4.2	5.8	5.8
Operation Range (Outdoor)	Cooling	Min / Max	°C DB	-15 / 48	-15 / 48	-15 / 48
	Heating	Min / Max	°C WB	-18 / 18	-18 / 18	-18 / 18
Power Supply			Ø / V / Hz	1 / 220-240 / 50	1 / 220-240 / 50	3 / 380-415 / 50
Power Supply Cable			No. x mm²	3C x 2.5	3C x 5.0	5C x 2.5
Transmission Cable			No. x mm²	3C x 2.5	4C x 0.75	4C x 0.75
Circuit Breaker			A	4C x 0.75	40	20
Piping Length Total		Min / Max	m	25	5 / 50	5 / 50
Piping Elevation Difference	IDU - ODU	Max	m	30	30	30
Piping Connection	Liquid		mm (inch)	Ø9.52 (3/8)	Ø9.52 (3/8)	Ø9.52 (3/8)
	Gas		mm (inch)	Ø15.88 (5/8)	Ø15.88 (5/8)	Ø15.88 (5/8)

※ For our policy of continuous product improvement, specification, design and features are subject to change without prior notice.

Note : 1. Due to our policy of innovation some specifications may be changed without notification.

2. Definition of Power Input Nominal conditions – Performance tested under EN14511

3. Capacities are based on the following conditions : Cooling : - Indoor Temperature 27°C DB / 19°C WB - Outdoor Temperature 35°C DB / 24°C WB  
Heating : - Indoor Temperature 20°C DB / 15°C WB - Outdoor Temperature 7°C DB / 6°C WB

4. Annual energy consumption : based on average use of 350 running hours in cooling and 1,400 hours in heating per year at seasonal condition

5. This product contains fluorinated greenhouse gases (R410A)

# AHU SOLUTION



SINGLE SPLIT AHU SOLUTION

## AHU COMBINATION

### Air Handling Applications

Economically feasible solution for pair application with air handling units.

#### Return / Room Air Temperature Control

- Temp. Sensors
  - Comm. Line
  - Central Comm. Line to ODU
  - ◆ Ref. Pipe
- $T_E$  = Evaporator Temperature (Liquid Pipe / Gas Pipe)  
 $T_R$  = Return Air Temperature  
 $T_{ROOM}$  = Room Air Temperature

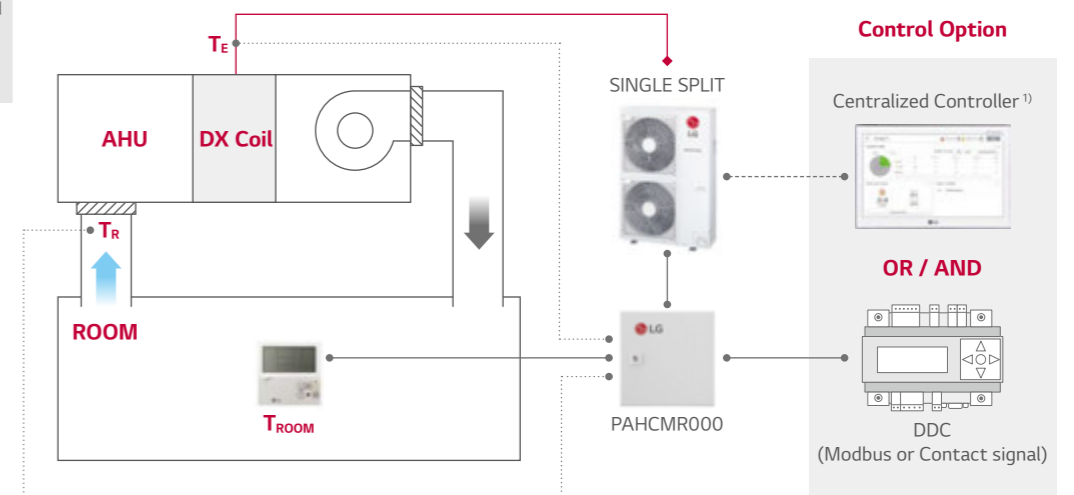

#### Discharge Air Temperature Control

- Temp. Sensors
  - Comm. Line
  - Central Comm. Line to ODU
  - ◆ Ref. Pipe
- $T_E$  = Evaporator Temperature (Liquid Pipe / Gas Pipe)  
 $T_D$  = Discharge Air Temperature  
 $T_{ROOM}$  = Room Air Temperature

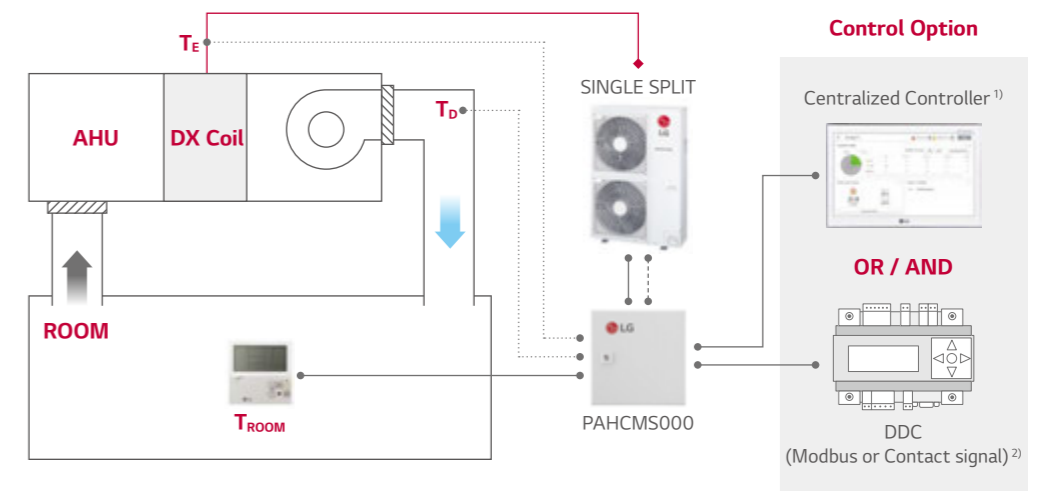

1) PI485(PMNFP14A1) is required for using centralized controller  
 2) In case of applying DDC with contact signal, discharge air temperature should be measured and controlled by DDC  
 3) For more detail, please refer to the PDB of AHU Communication Kit

# AHU COMMUNICATION KITS

## COMMUNICATION KIT

- NEW!** PAHCMR000
- NEW!** PAHCMS000



## Specifications

MODEL	COMBINATION		DESCRIPTION	DIMENSIONS (MM)		
	OUTDOOR UNIT	CENTRALIZED CONTROLLER		W	H	D
PAHCMR000	Single Split	•	Return / Room air temperature control by DDC or LG individual / centralized controller	300	300	155
PAHCMS000	Single Split	•	Discharge air temperature control by DDC or LG individual / centralized controller	380	300	155

## Function list for Communication kit

FUNCTION LIST*	PAHCMR000	PAHCMS000	NOTE
Comm. Kit Operation	On / Off	On / Off	
Operation Mode <sup>1)</sup>	Cooling / Heating	Cooling / Heating	
Return (room) Air Temperature	16-30°C	-	
Discharge Air Temperature <sup>2)</sup>	-	16-30°C	Available in case of using DDC with Modbus or LG Control system
Fan Speed <sup>3)</sup>	Low / Middle / High	Low / Middle / High	It may not be possible depending on the particular condition
Forced Thermal On / Off	On / Off	-	Available in case of using DDC with contact signal
Capacity Control	-	•	Available in case of using DDC with Modbus or contact signal
Comm. Kit Operation	On / Off	On / Off	
Operation Mode <sup>1)</sup>	Cooling / Heating	Cooling / Heating	Available in case of using DDC with Modbus or LG Control system
Fan Speed	Low / Middle / High	Low / Middle / High	
Error Alarm	•	•	
Compressor On / Off	On / Off	On / Off	Available in case of using DDC with Modbus or LG individual controller PAHCMR000 doesn't provide this in case of using DDC with contact signal

1) Available operation mode can be varied depending on the setting of AHU Communication Kit.

2) This range may differ depending on the type of controller

3) To control and monitor the fan speed, DO ports for the fan speed status have to be connected with the fan unit

\* Some of functions may not be possible depending on the setting of AHU Communication Kit. For more details of condition, please refer to the product data book

## Combination Table

### STANDARD INVERTER (1-phase)

		UU18WR.U20	UU24WR.U40	UU30WR.U40	UU36WR.U30	UU42WR.U30	UU48WR.U30	UU60WR.U30
Capacity	Cooling kW	4.7	7.7	8.0	10.0	12.5	13.9	14.6
	Heating kW	5.5	8.0	9.0	11.0	14.0	15.4	16.9
AHU Kit	PAHCMR000	•	•	•	•	•	•	•
	PAHCMS000	•	•	•	-	-	-	-

### STANDARD INVERTER (3-phase)

		UU37WR.U30	UU43WR.U30	UU49WR.U30	UU61WR.U30	UU70W.U34	UU85W.U74
Capacity	Cooling kW	10.0	12.5	13.9	14.6	19.0	23.0
	Heating kW	11.0	14.0	15.4	16.9	22.4	27.0
AHU Kit	PAHCMR000	•	•	•	•	•	•
	PAHCMS000	-	-	-	-	•	•

# ACCESSORIES



SINGLE SPLIT ACCESSORIES

# LG Wi-Fi MODEM

Control LG air conditioners via using the internet devices as Android or iOS bases smartphones

## PWFMDD200

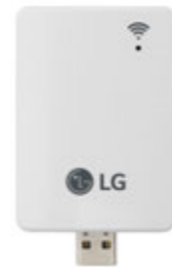

### Features

- Access LG air conditioner anytime and from anywhere with Wi-Fi equipped device
- LG's exclusive Home Appliances control app(SmartThinQ) is available
- Simple operation for various functions
  - On/Off
  - Fan Speed
  - Energy Monitoring <sup>1)</sup>
  - Operation Mode
  - Vane Control <sup>2)</sup>
  - Filter Management
  - Current/Set Temperature
  - Reservation (Sleep, Weekly On/Off)
  - Error check

MODEL NAME	PWFMDD200
Size (W x H x D, mm)	48 x 68 x 14
Interfaceable Products	Single Indoor unit <sup>3)</sup>
Connection Type	Indoor unit 1:1
Communication Frequency	2.4 GHz
Wireless Standards	IEEE 802.11b/g/n
Mobile Application	LG Smart ThinQ (Android v4.1(Jellybean) or higher, iPhone iOS 9.0 or higher)
Optional Extension Cable	PWYREW000 (10m extension)

\* Functionality may be different according to each IDU model  
 \* User interface of application shall be revised for its design and contents improvement  
 \* Application is optimized for smartphone use, so it may not be well functioning with tablet devices  
 1) LG Centralized controller and PDI installation is required for this function  
 2) Vane Control may not be possible according to the type of Indoor unit  
 3) For the compatibility with Indoor unit, please contact regional office



### Overview

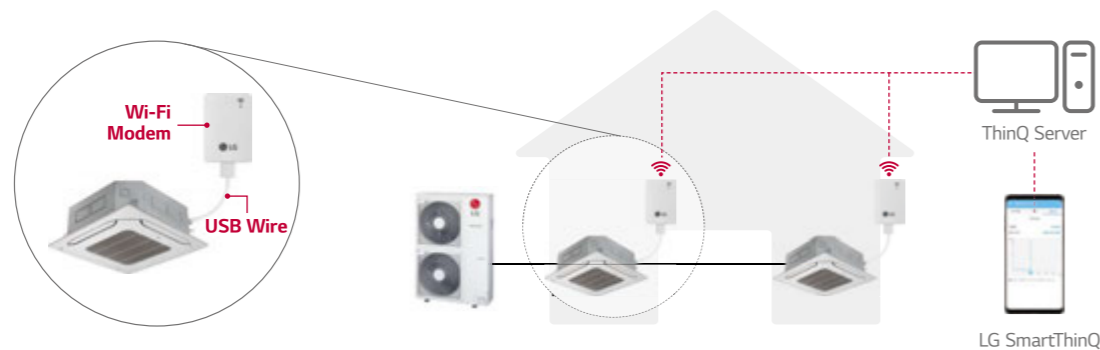

\* Search "LG Smart ThinQ" on Google market or Appstore then download the app.  
 \* Internet service with Wi-Fi connection has to be available

SINGLE SPLIT ACCESSORIES

# ACCESSORIES

## Standard Wired Remote Controller

### Standard III



PREMTB100 PREMTBB10

### Standard II



PREMTB001 PREMTBB01

Model Name	PREMTB100 PREMTBB10	PREMTB001 PREMTBB01
Operation Mode	On/Off, Fan Speed Control, Temperature Setting	
Mode Change	Cooling / Heating / Auto / Dehumidification / Fan	
Auto Swing / Vane Control	•	•
Reservation	Simple / Sleep / On, Off / Weekly / Holiday	
Time Display	•	•
Electrical Failure Compensation	•	•
Child Lock	•	•
Operation Status LED	•	•
Indoor Temperature Display	•	•
Wireless Remote Controller Receiver	-	•
Size (W x H x D, mm)	120 x 120 x 16	120 x 121 x 16
Backlight	•	•

\* Refer to each model PDB for applicable models.

## Remote Controller



PQWRHQ0FDB

## PI 485

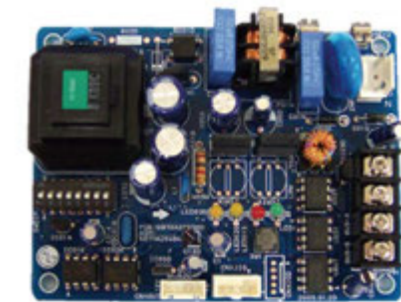

PMNFP14A1

Power : Single phase AC 220V 50/60Hz  
 Max. no of the indoor units that can be connected: 64 UNITS  
 Model applied : RAC / Multi / Single / Thermo V

\* Refer to each product PDB for applicable models

## Dry Contact



\* Refer to each product PDB for applicable models

MODEL	PDRYCB000	PDRYCB400	PDRYCB300	PDRYCB500
Contact Point	1 Control Point	2 Control Point	8 Control Point	Modbus RTU
Power Input	AC 220V from outside power source	DC 5V & 12V from indoor unit PCB	DC 5V & 12V from indoor unit PCB	DC 5V & 12 V from indoor unit PDB
Voltage / Non Voltage Input		•	•	
On / Off Control	•	•	•	•
Lock / Unlock	•	•	•	
Fan Speed Setting			•	•
Thermo Off		•	•	
Energy Saving		•		
Temperature Setting		•	•	•
Error Monitoring	•	•	•	•
Operation Monitoring	•	•	•	•

# CEILING CASSETTE

## CT09R.NR0 / CT12R.NR0

(Unit : mm)

Part Name	Part Name
1 Gas Pipe Connection	1 Gas Pipe Connection
2 Liquid Pipe Connection	2 Liquid Pipe Connection
3 Drain Pipe Connection	3 Drain Pipe Connection
4 Power and Communication cable routing hole	4 Power and Communication cable routing hole
5 Wired remote controller wire routing hole	5 Wired remote controller wire routing hole
6 Air Intake	6 Air Intake
7 Air Outlet	7 Air Outlet
8 Decoration Panel (PT-QCHW0)	8 Decoration Panel (PT-QCHW0)
9 Decoration Corner Cover	9 Decoration Corner Cover
10 Decoration Coner Display Cover	10 Decoration Coner Display Cover
11 Flexible Drain Hose	11 Flexible Drain Hose
12 Fresh air Intake Hole	12 Fresh air Intake Hole

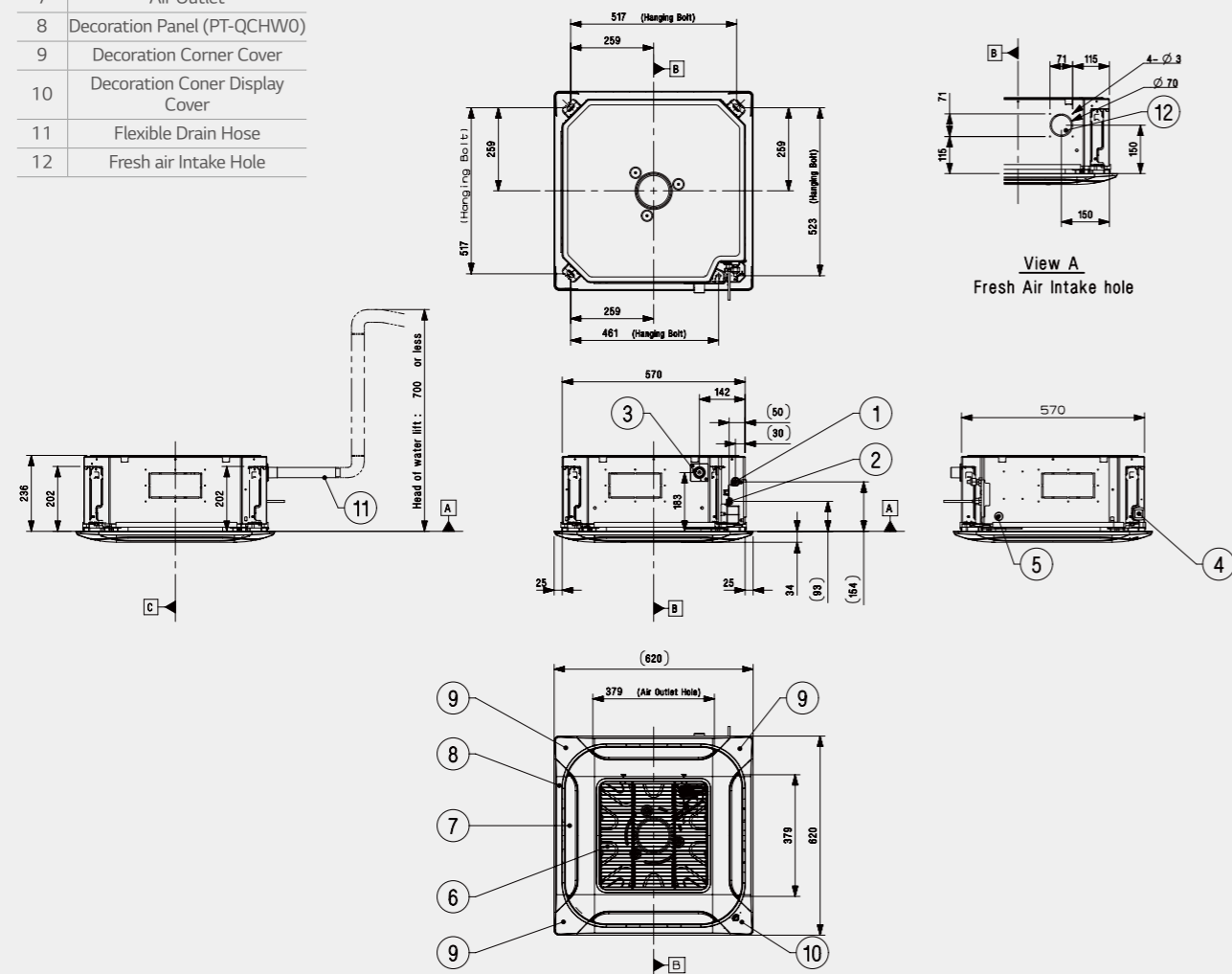

## CT18R.NQ0

(Unit : mm)

Part Name	Part Name
1 Gas Pipe Connection	1 Gas Pipe Connection
2 Liquid Pipe Connection	2 Liquid Pipe Connection
3 Drain Pipe Connection	3 Drain Pipe Connection
4 Power and Communication cable routing hole	4 Power and Communication cable routing hole
5 Wired remote controller wire routing hole	5 Wired remote controller wire routing hole
6 Air Intake	6 Air Intake
7 Air Outlet	7 Air Outlet
8 Decoration Panel (PT-QCHW0)	8 Decoration Panel (PT-QCHW0)
9 Decoration Corner Cover	9 Decoration Corner Cover
10 Decoration Coner Display Cover	10 Decoration Coner Display Cover
11 Flexible Drain Hose	11 Flexible Drain Hose
12 Fresh air Intake Hole	12 Fresh air Intake Hole

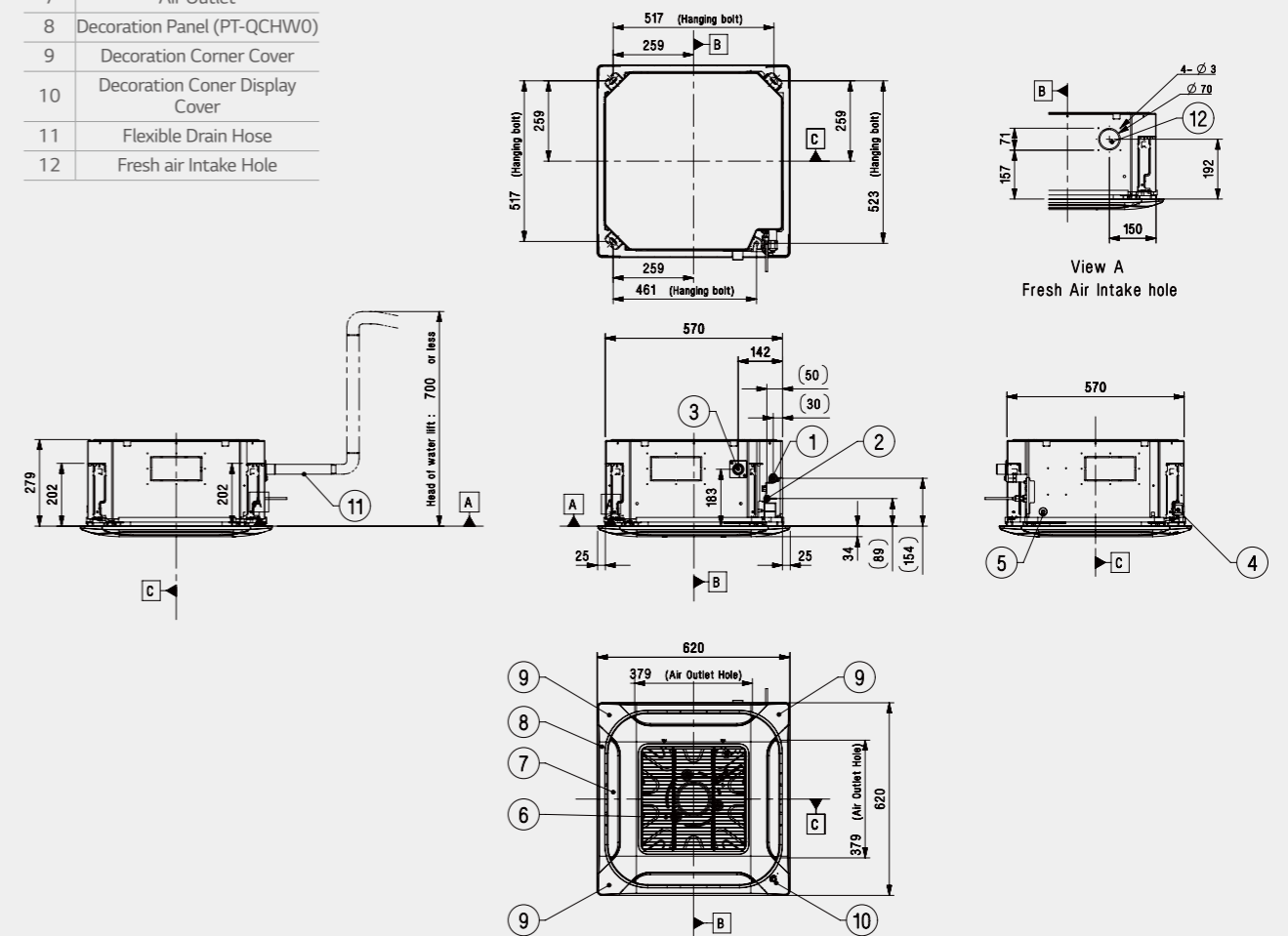

# CEILING CASSETTE

## CT24R.NP0

(Unit : mm)

Part Name
1 Gas Pipe Connection
2 Liquid Pipe Connection
3 Drain Pipe Connection
4 Power and Communication cable routing hole
5 Wired remote controller wire routing hole
6 Air Inlet
7 Air Outlet
8 Decoration Panel (PT-MCHW0)
9 Decoration Corner Cover
10 Flexible Drain Hose
11 Fresh air Intake Hole

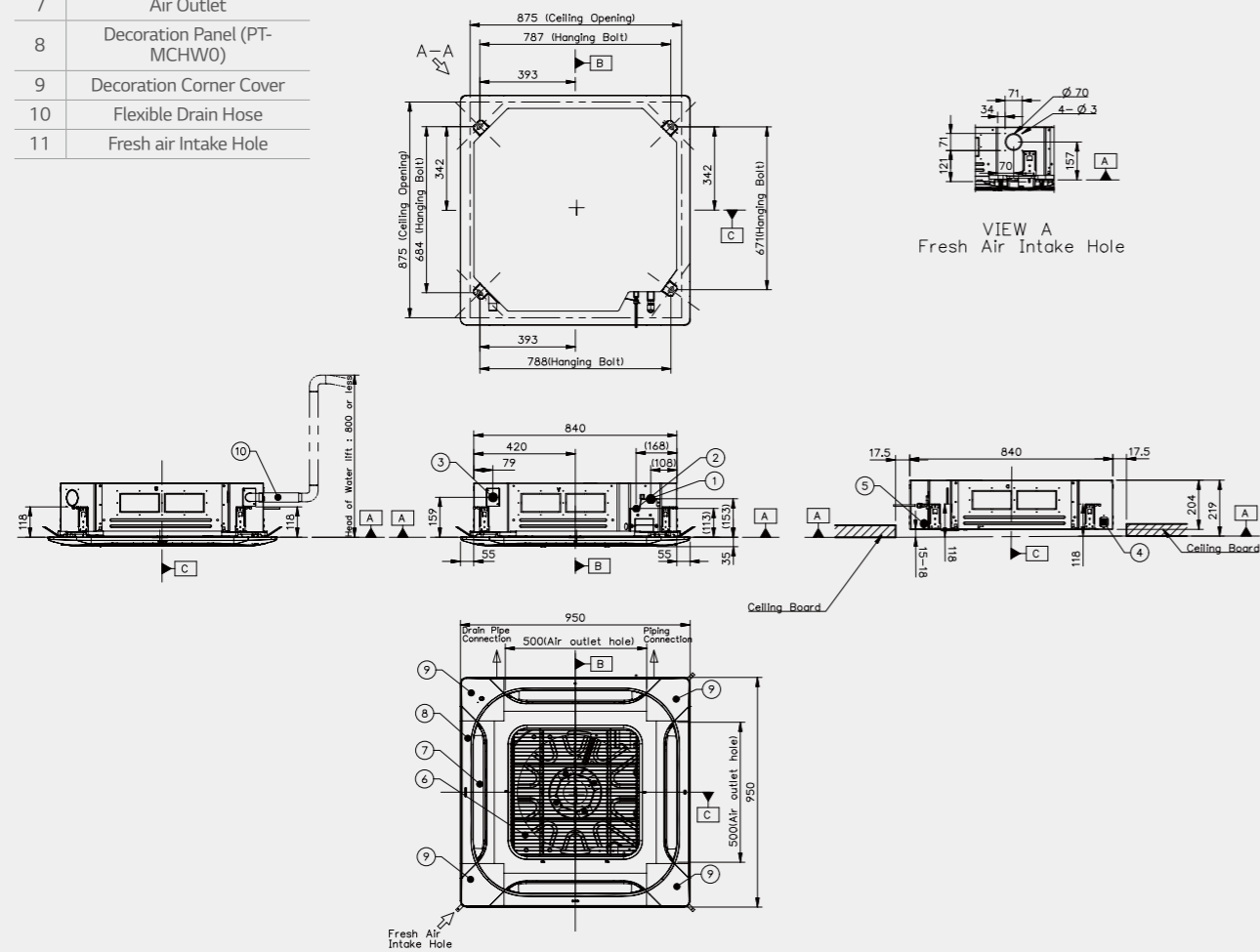

## UT36R.NM0 / UT42R.NM0 / UT48R.NM0 / UT60R.NM0

(Unit : mm)

Part Name
1 Gas Pipe Connection
2 Liquid Pipe Connection
3 Drain Pipe Connection
4 Power and Communication cable routing hole
5 Wired remote controller wire routing hole
6 Air Inlet
7 Air Outlet
8 Decoration Panel (PT-MCHW0)
9 Decoration Corner Cover
10 Flexible Drain Hose
11 Fresh air Intake Hole

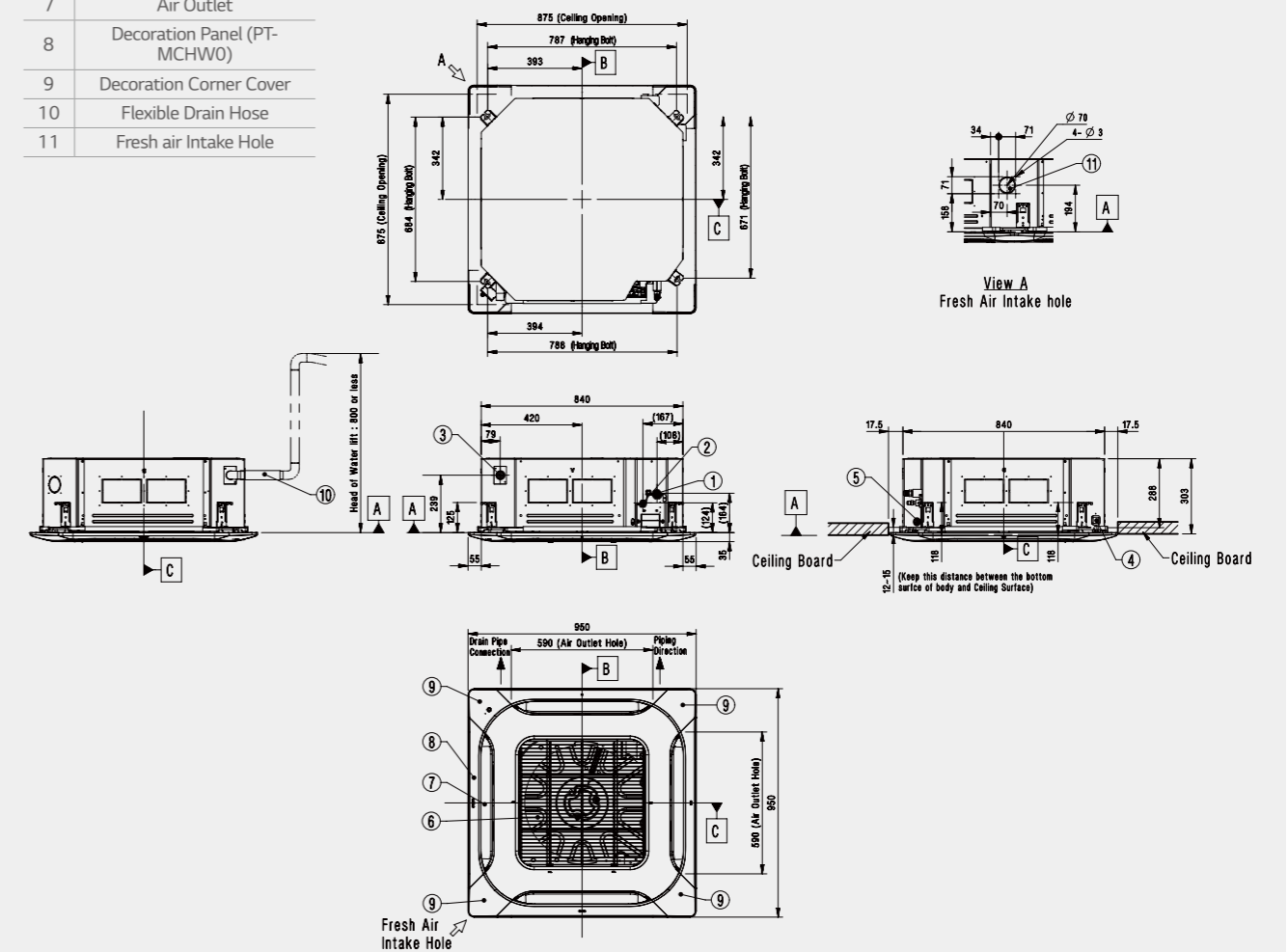

# CEILING CONCEALED DUCT

## CM18R.N10 / CM24R.N10

(Unit : mm)

Part Name
1 Gas pipe connection
2 Liquid pipe connection
3 Drain pipe connection
4 Power and Communication Cable Routing Hole
5 Wired Remote Controller Wire Routing Hole
6 Air Inlet Vent
7 Air Outlet Vent
8 Air Filter
9 Control Cover

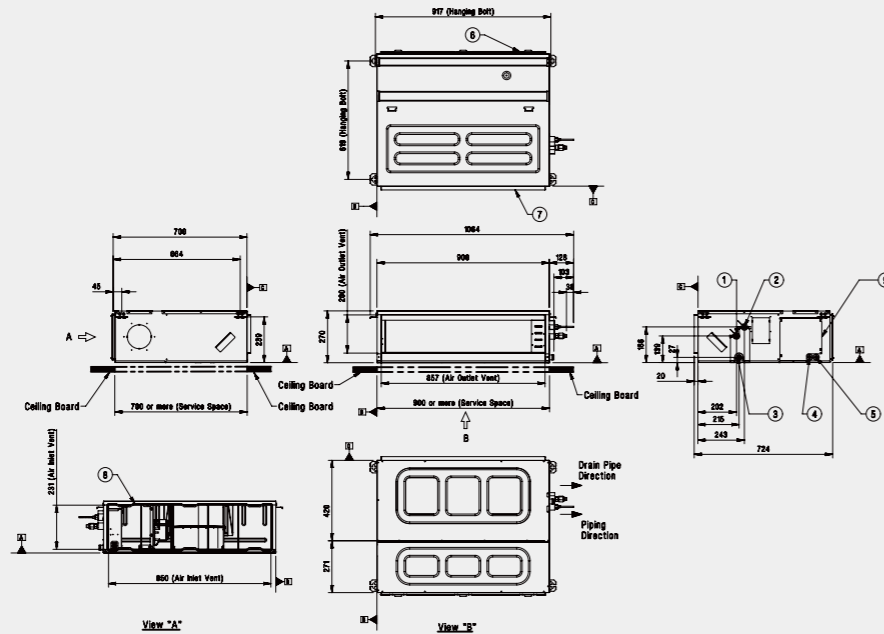

## UM48R.N30 / UM60R.N30

(Unit : mm)

Part Name
1 Refrigerant pipe connection
2 Drain pipe connection
3 Power and communication Cable Hole
4 Remote Controller Cable Hole
5 Air Inlet
6 Air Outlet
7 Air Filters
8 Control Cover

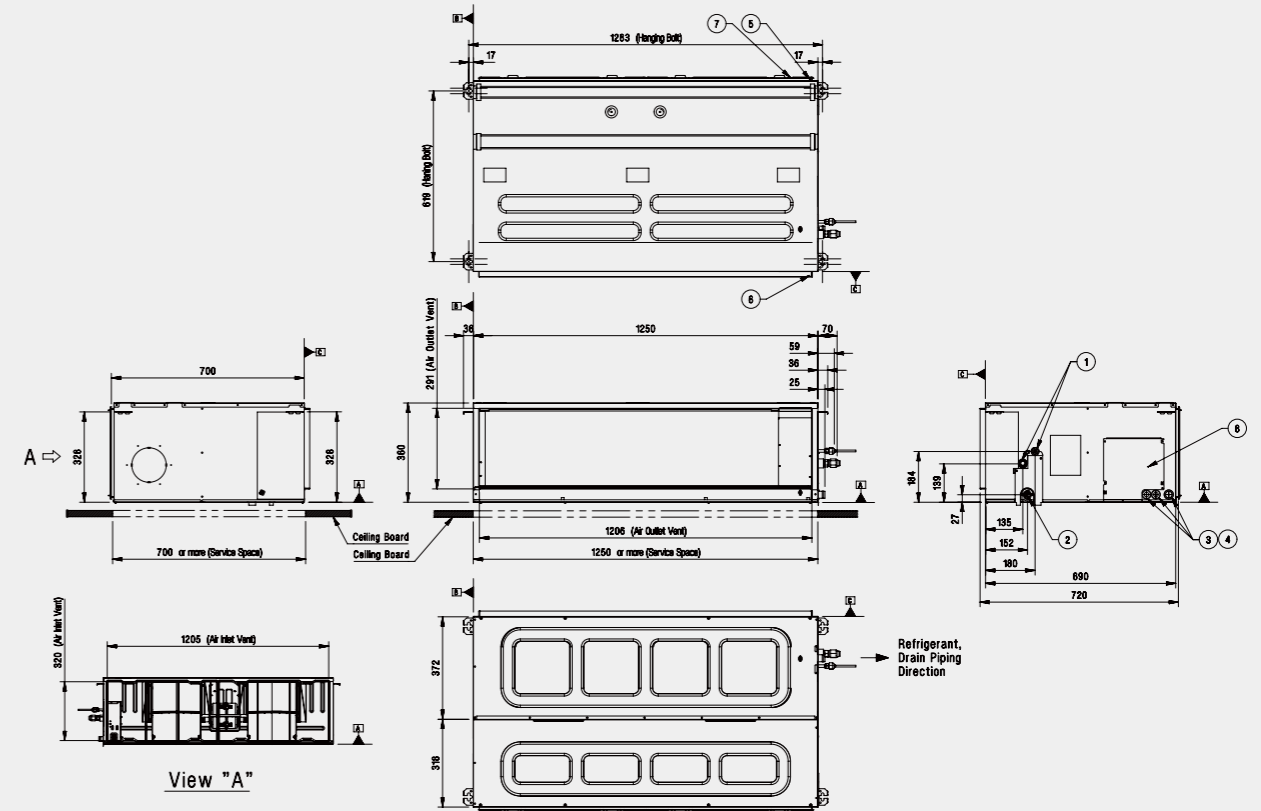

## UM36R.N20 / UM42R.N20

(Unit : mm)

Part Name
1 Gas pipe connection
2 Liquid pipe connection
3 Drain pipe connection
4 Power and Communication Cable Routing Hole
5 Remote Controller Cable Hole
6 Air Inlet
7 Air Outlet
8 Air Filter
9 Control Cover

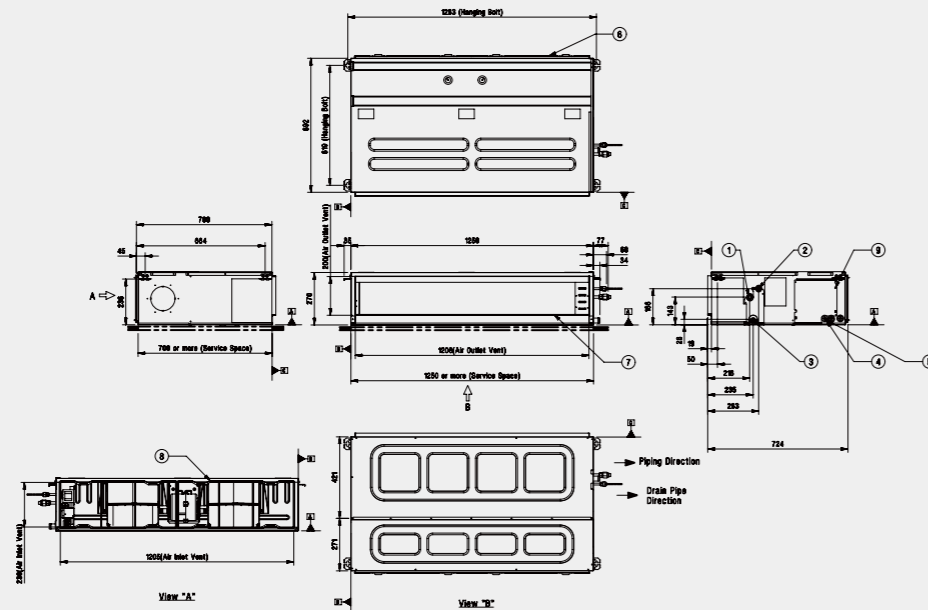

# CEILING CONCEALED DUCT

## CL09R.N20 / CL12R.N20 / CL18R.N20 / CL24R.N30

(Unit : mm)

Part Name	
1	Liquid pipe connection
2	Gas pipe connection
3	Drain pipe connection
4	Power supply connection
5	Air discharge
6	Air suction

Chassis	A	B	C	D
CB09L	774	700	733	660
CB12L CB18L CL09R CL12R CL18R	974	900	933	860
CB24L CL24R	1,174	1,100	1,133	1,060

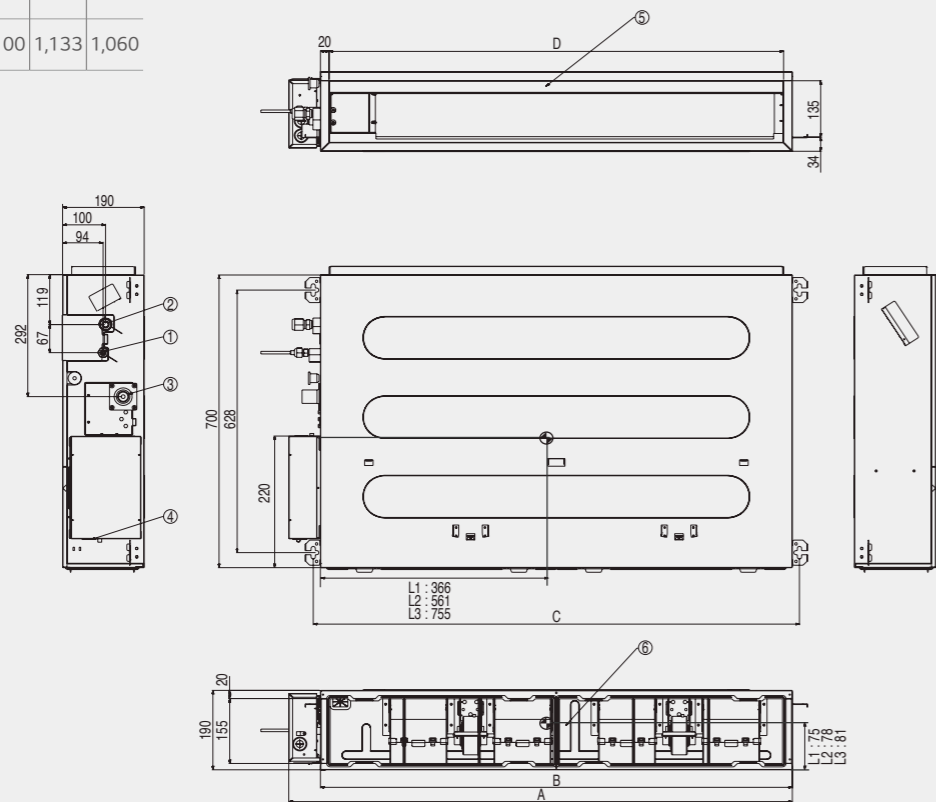

## UB70.N94 / UB85.N94

(Unit : mm)

Part Name	
1	Air suction flange
2	Air discharge flange
3	Control Box
4	Gas piping connection
5	Liquid pipe connection
6	Drain pipe connection
7	Drain pump (Option)

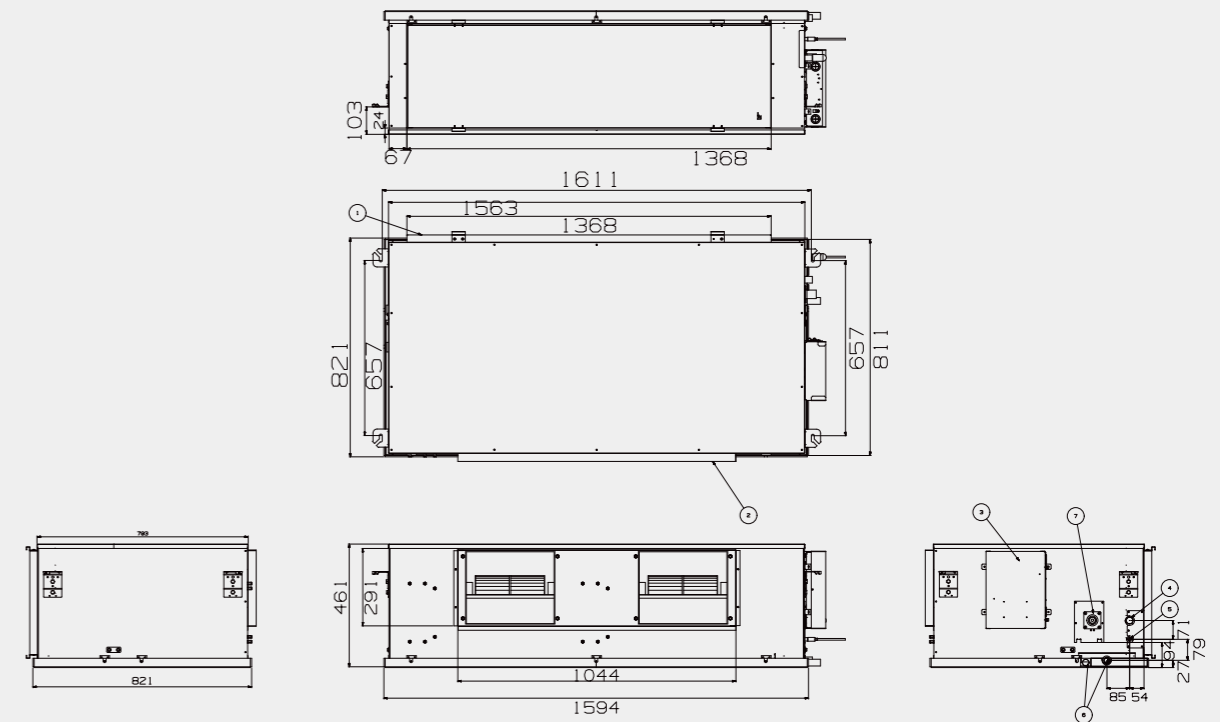



# CEILING SUSPENDED UNIT

## UV18R.N10 / UV24R.N10

(Unit : mm)

Part Name
1 Air Intake
2 Air Outlet
3 Remote Controller Signal Reciver
4 Drain hose routing hole
5 Refrigerant pipe and cable routing hole

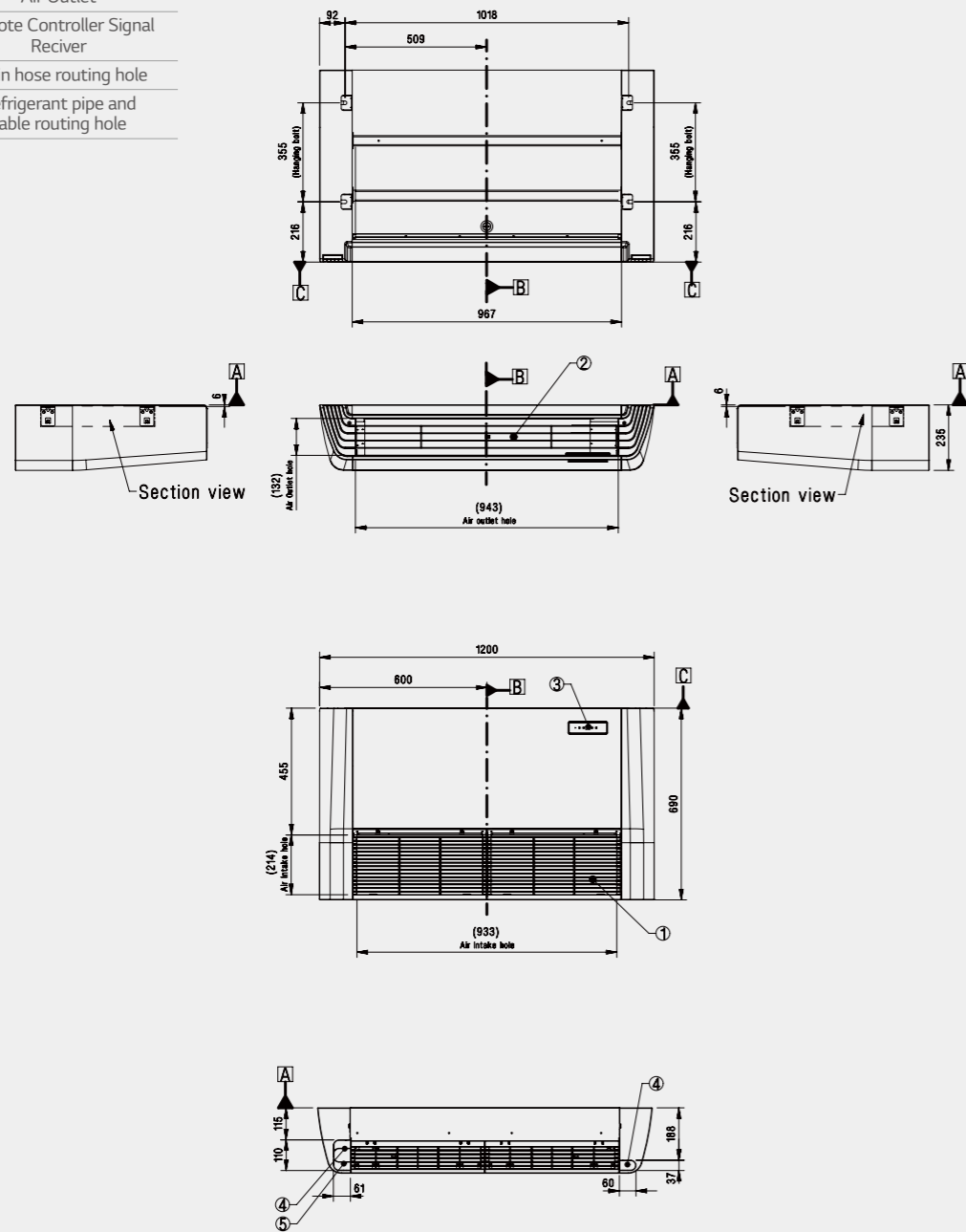

## UV36R.N20 / UV42R.N20 / UV48R.N20 / UV60R.N20

(Unit : mm)

Part Name
1 Air Intake
2 Air Outlet
3 Remote Controller Signal Reciver
4 Drain hose routing hole
5 Refrigerant pipe and cable routing hole

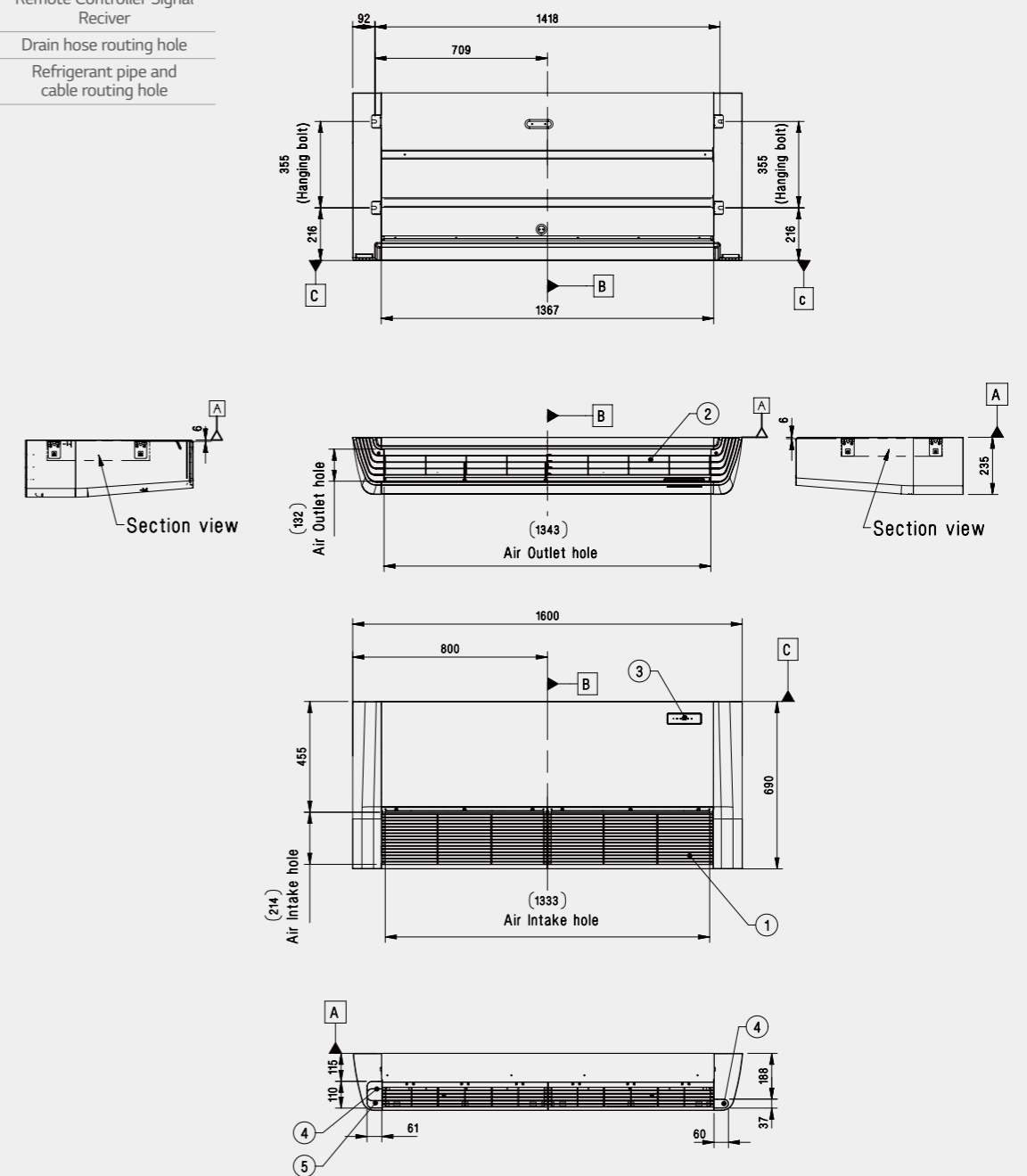

SINGLE SPLIT DIMENSIONS

# CEILING & FLOOR CONVERTIBLE

## CV09.NE2 / CV12.NE2

(Unit : mm)

Part Name
1 Front air discharge grille
2 Display & Single receiver
3 Air suction grille
4 Knockout hole
5 Installation plate

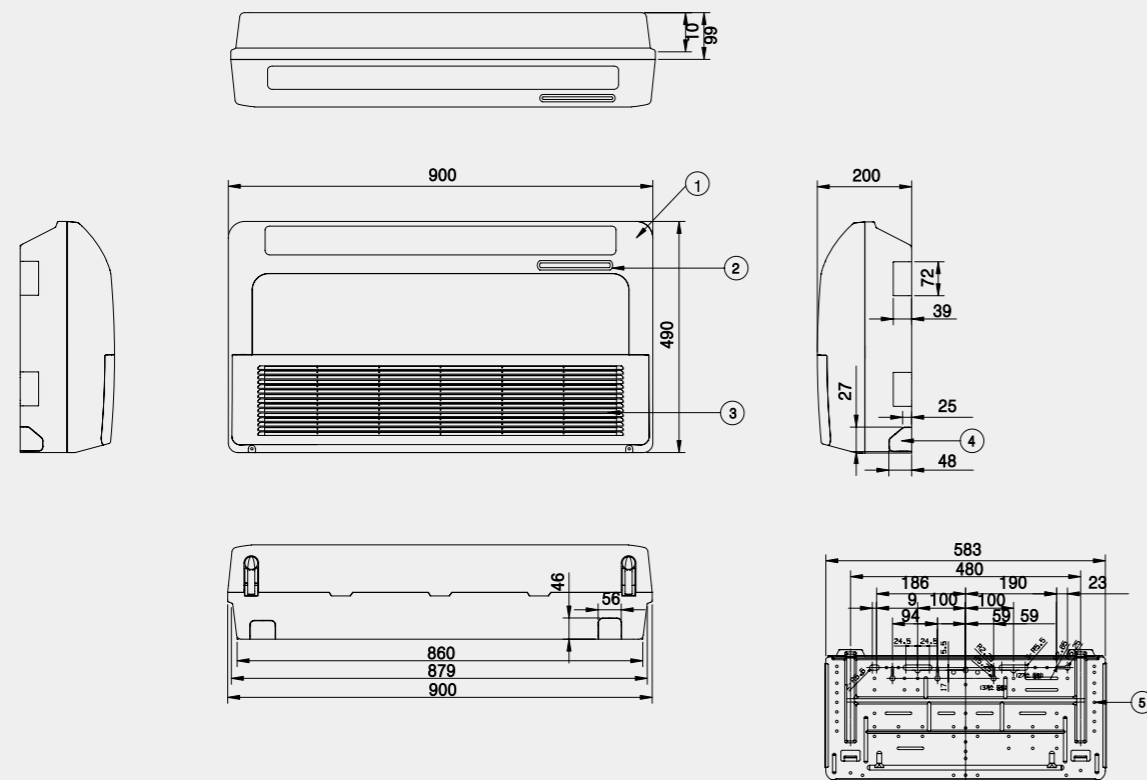

SINGLE SPLIT DIMENSIONS

# CONSOLE

## CQ09.NA0 / CQ12.NA0 / CQ18.NA0

(Unit : mm)

Part Name
1 Front air discharge grille
2 Display & Single receiver
3 Air suction grille

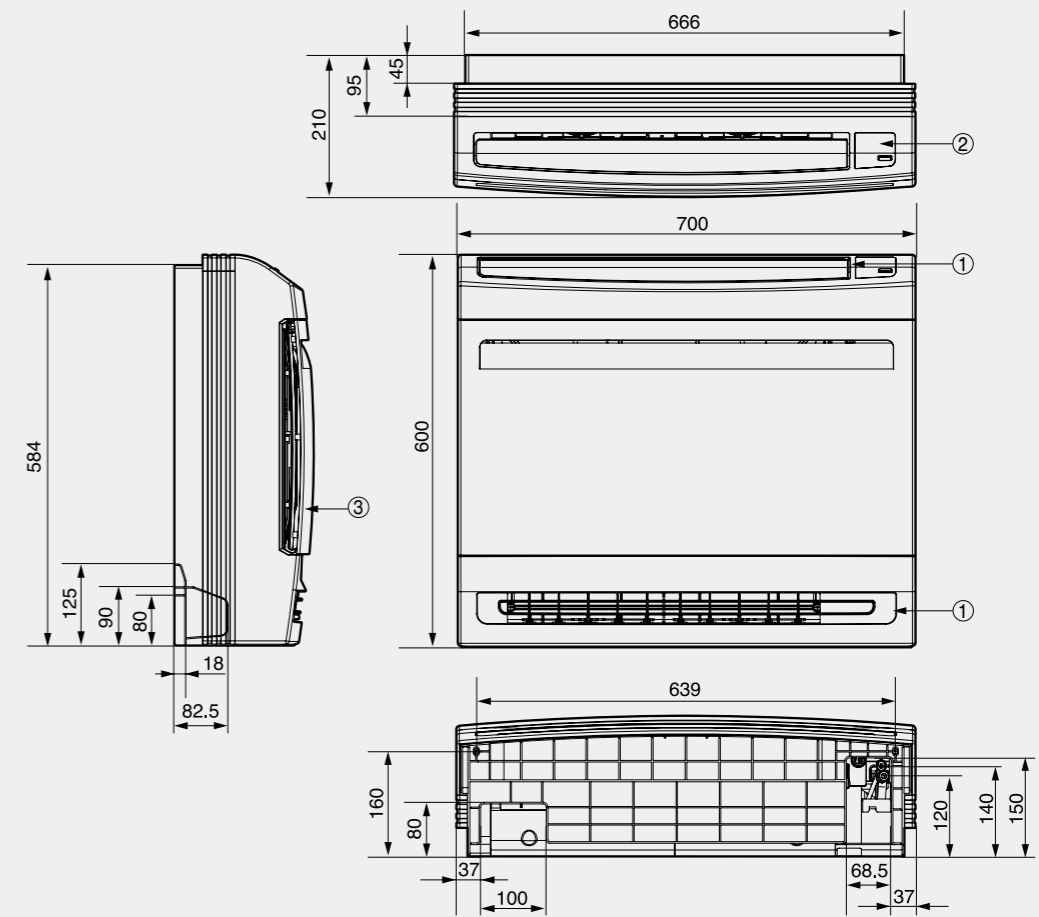

SINGLE SPLIT DIMENSIONS

# WALL MOUNTED

## UJ30.NV2 / UJ36.NV3

(Unit : mm)

	Part Name
1	Front Panel
2	Display & Signal Receiver
3	Air Suction Grille
4	Installation Plate

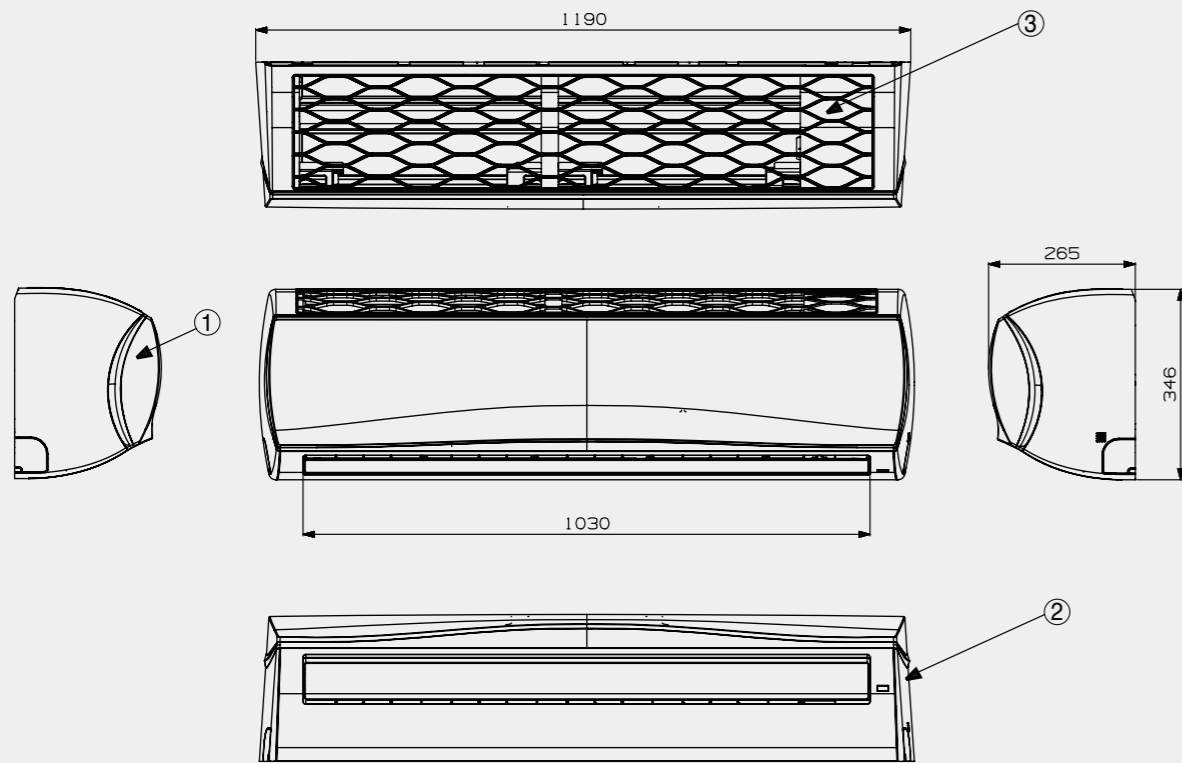

SINGLE SPLIT DIMENSIONS

# FLOOR STANDING

## UP48.NT2

(Unit : mm)

	Part Name
1	Front air discharge grille
2	Display & Single receiver
3	Air suction grille

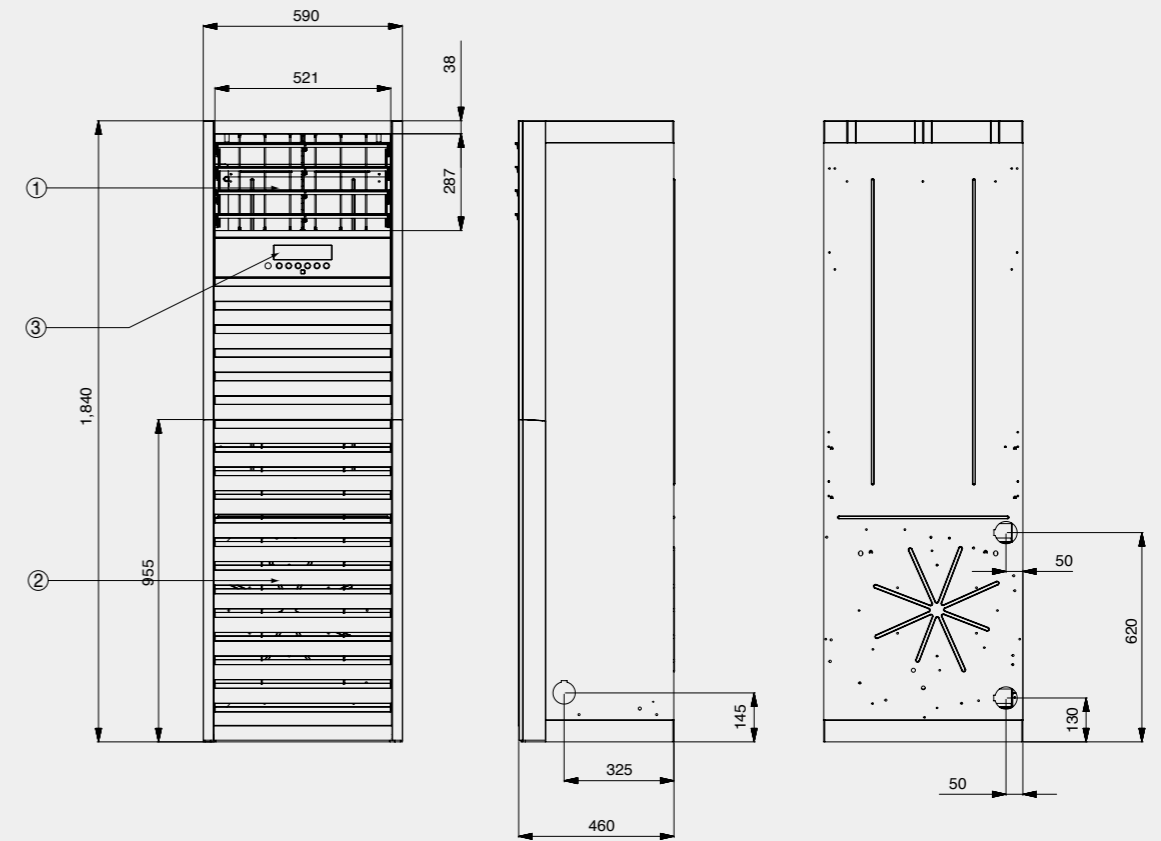

# UNIVERSAL OUTDOOR

## UU09WR.ULO / UU12WR.ULO

(Unit : mm)

Part Name
1 Air Outlet
2 Control cover & SVC valve cover
3 Power and communication cable connection
4 Gas Pipe connection
5 Liquid Pipe connection
6 Power and communication cable routing hole
7 Refrigerant pipe routing hole
8 Handle
9 Intake air temperature sensor cover

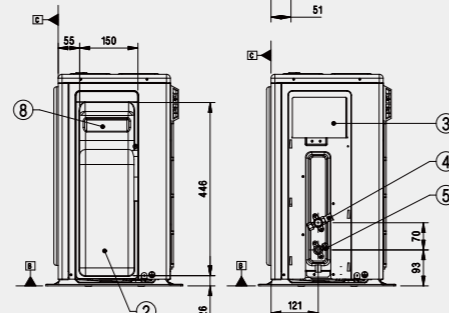
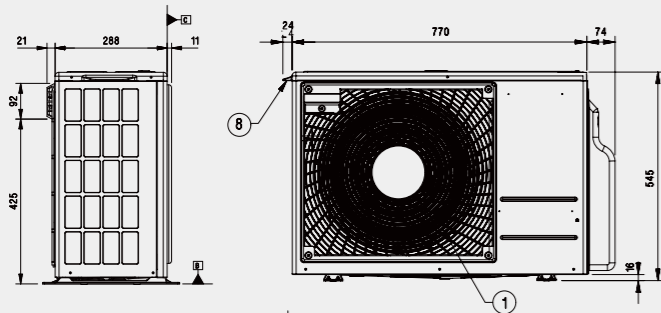
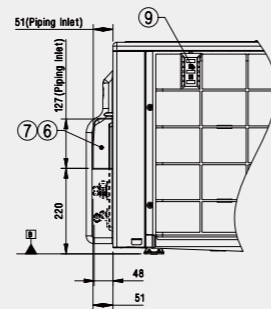
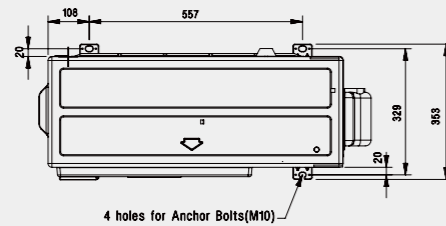
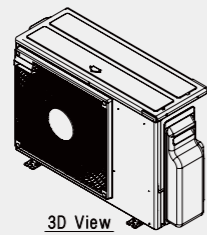

Side View  
(removed valve cover)

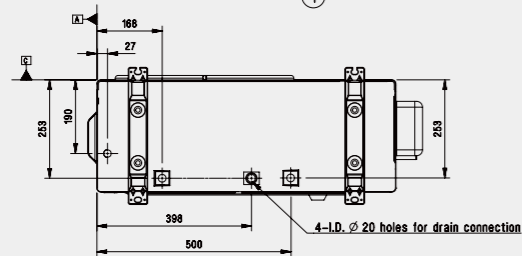

## UU18WR.U20

(Unit : mm)

Part Name
1 Air Outlet
2 Control cover & SVC valve cover
3 Power and communication cable connection
4 Gas Pipe Connection
5 Liquid Pipe Connection
6 Handle
7 Intake air temperature sensor cover

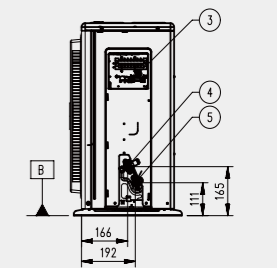
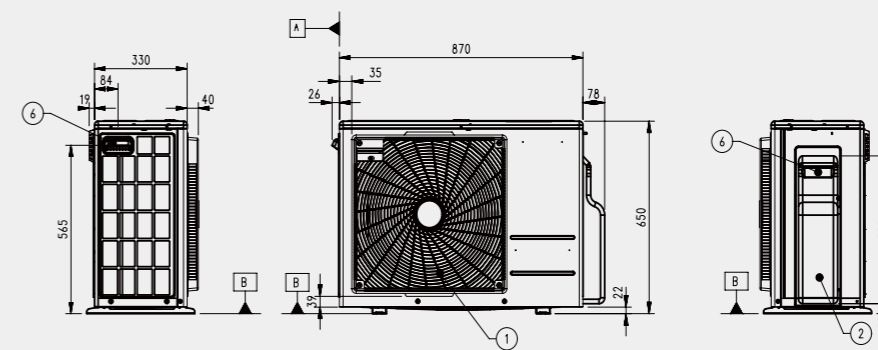
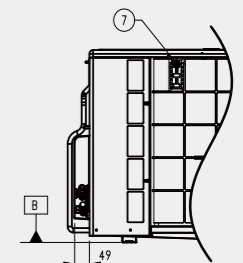
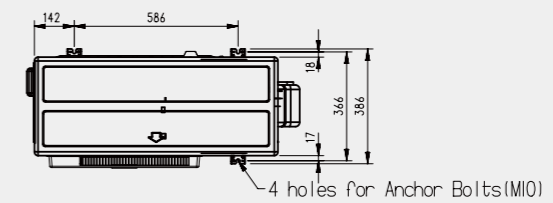
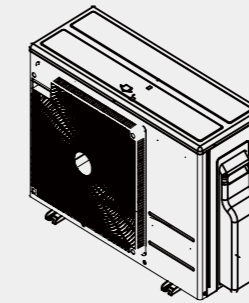

Side View  
(removed valve cover)

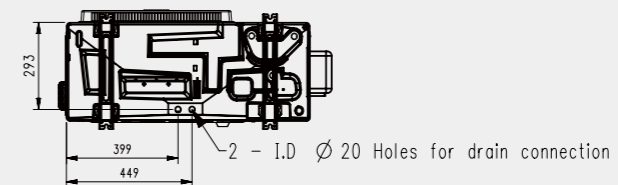

# UNIVERSAL OUTDOOR

## UU24WR.U40

(Unit : mm)

Part Name
1 Air Outlet
2 Power and communication cable Hole
3 Gas Pipe Connection
4 Liquid Pipe Connection
5 Handle
6 Pipe routing hole (front)
7 Pipe routing hole (side)
8 Pipe routing hole (back)

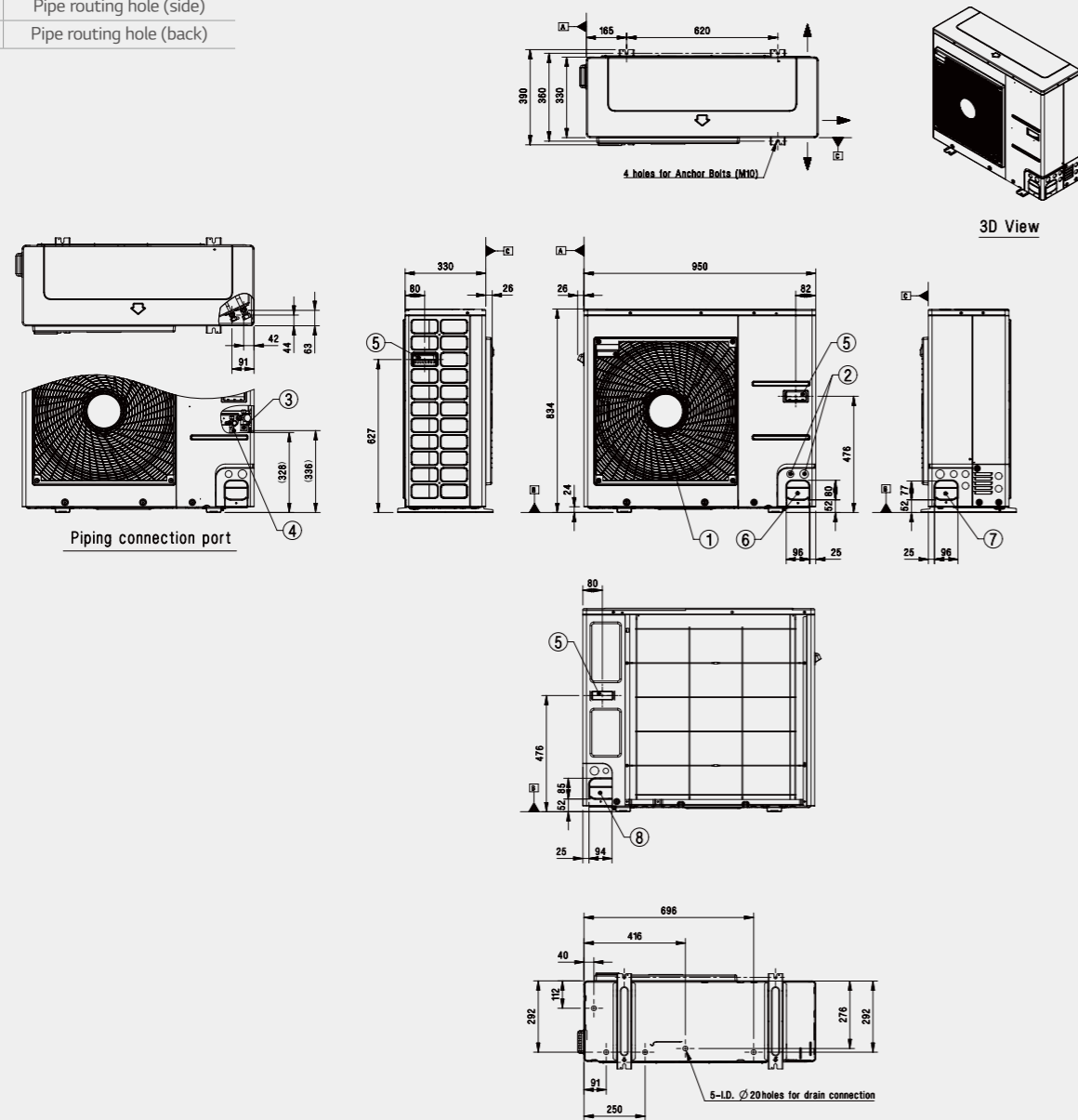

## UU36WR.U30 / UU37WR.U30 / UU42WR.U30 / UU43WR.U30 UU48WR.U30 / UU49WR.U30 / UU60WR.U30 / UU61WR.U30

(Unit : mm)

Part Name
1 Air Outlet
2 Power and communication cable hole
3 Gas Pipe Connection
4 Liquid Pipe Connection
5 Handle
6 Pipe routing hole (front)
7 Pipe routing hole (side)
8 Pipe routing hole (back)

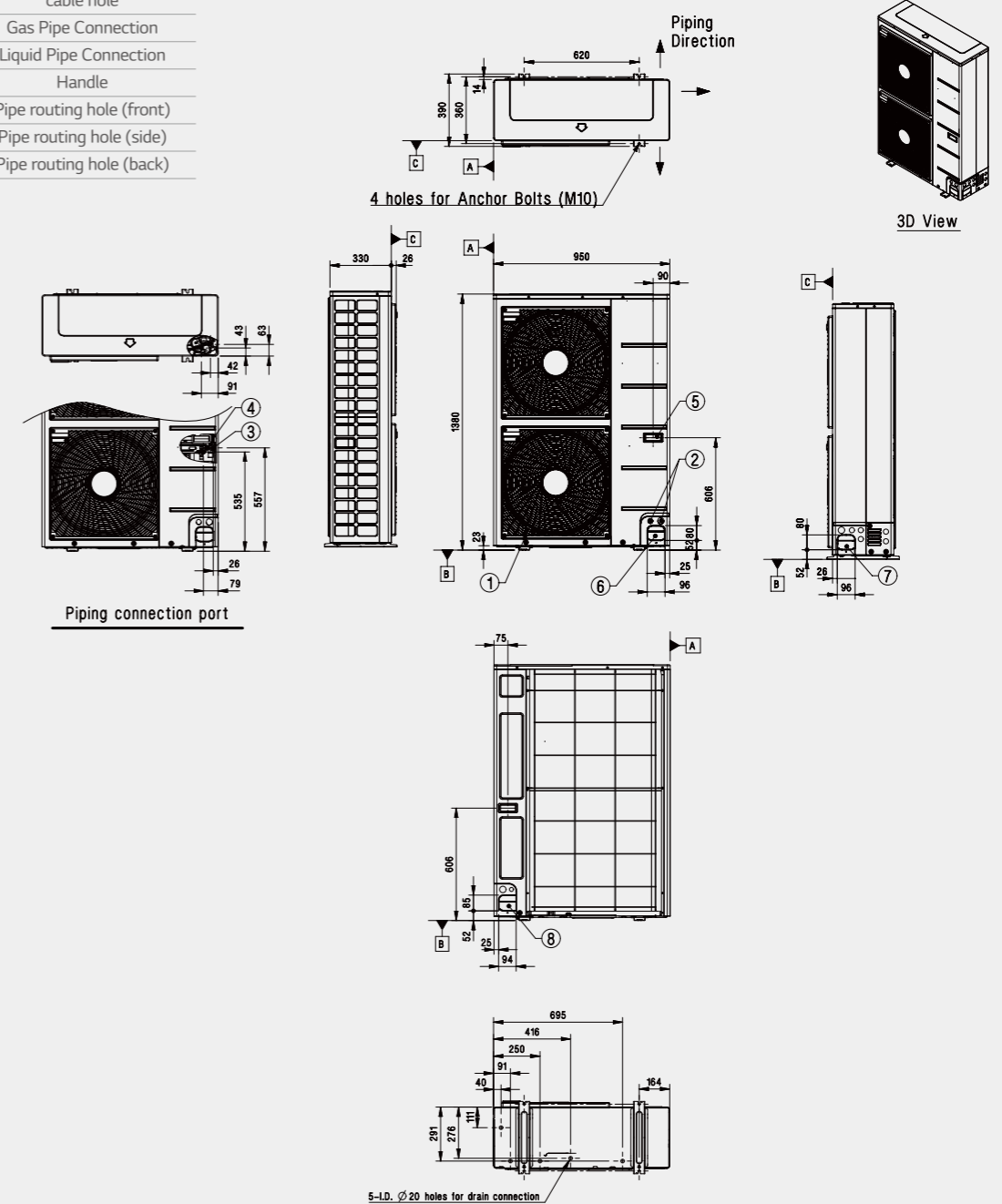

# UNIVERSAL OUTDOOR

## UU70W.U34

(Unit : mm)

Part Name
1 Air discharge grille
2 Gas pipe connection
3 Liquid pipe connection
4 Power & Transmission connection

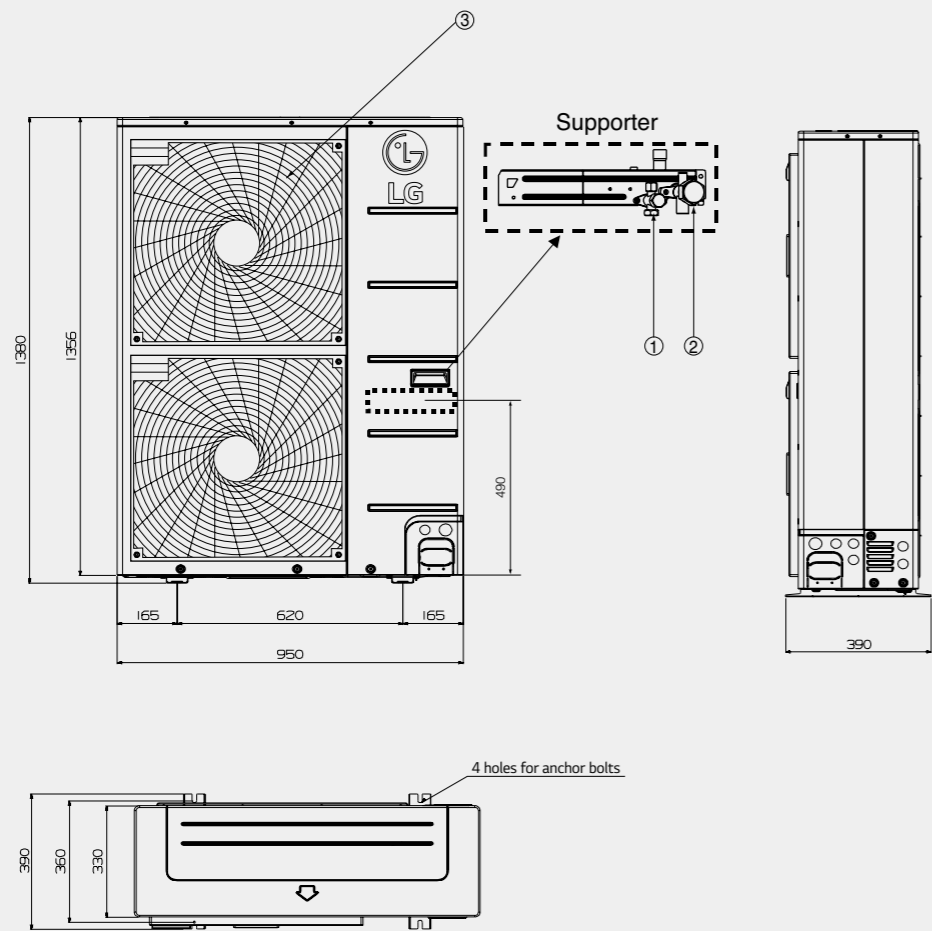

## UU85W.U74

(Unit : mm)

Part Name
1 Gas piping connection
2 Liquid piping connection
3 Air Inlet
4 Air Outlet
5 Drain Hole
6 Power and communication Cable Hole
7 Power and communication Cable Hole
8 Power and communication Cable Hole

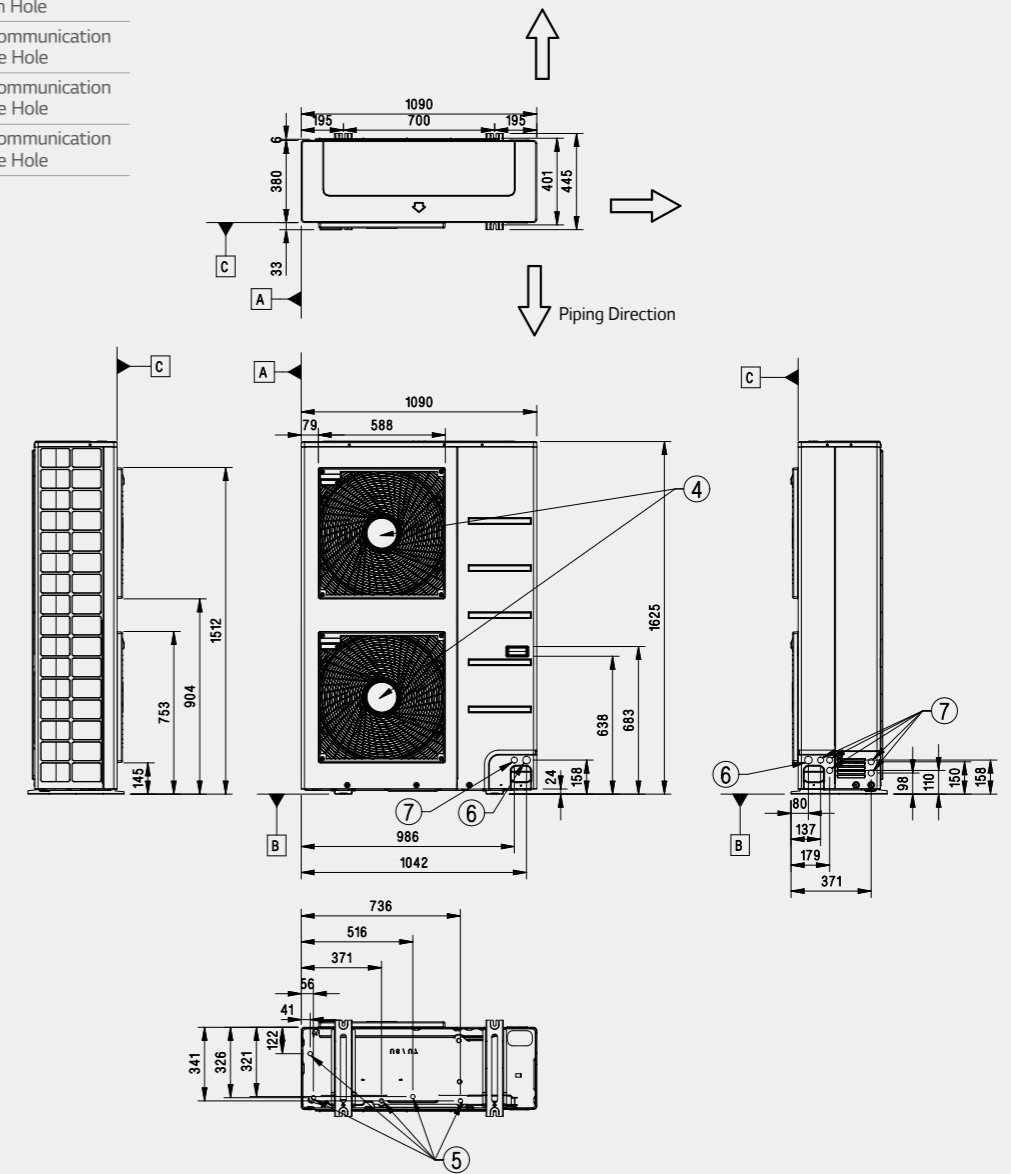

# HEATING

MONOBLOC (MID TEMPERATURE)

SPLIT (HIGH TEMPERATURE)

DOMESTIC HOT WATER TANK

SPLIT (LOW TEMPERATURE)

SPLIT (DHW TANK INTEGRATED)

ACCESSORIES



# WHAT IS THERMA V

## What is LG THERMA V?

THERMA V is LG's Air to Water Heat Pump system, especially designed for new and renovated housings. It is an in-house design by LG's advanced heating technology consuming less energy.

THERMA V can be used as a multi-purpose heating Solution ranging from floor heating to hot water supply using various heat sources.



## Energy Efficient Application

THERMA V offers the best solution for home heating and hot water supply with LG's inverter technology. It is 4 times more energy efficient than the traditional boiler system by absorbing energy from the outdoor environment.

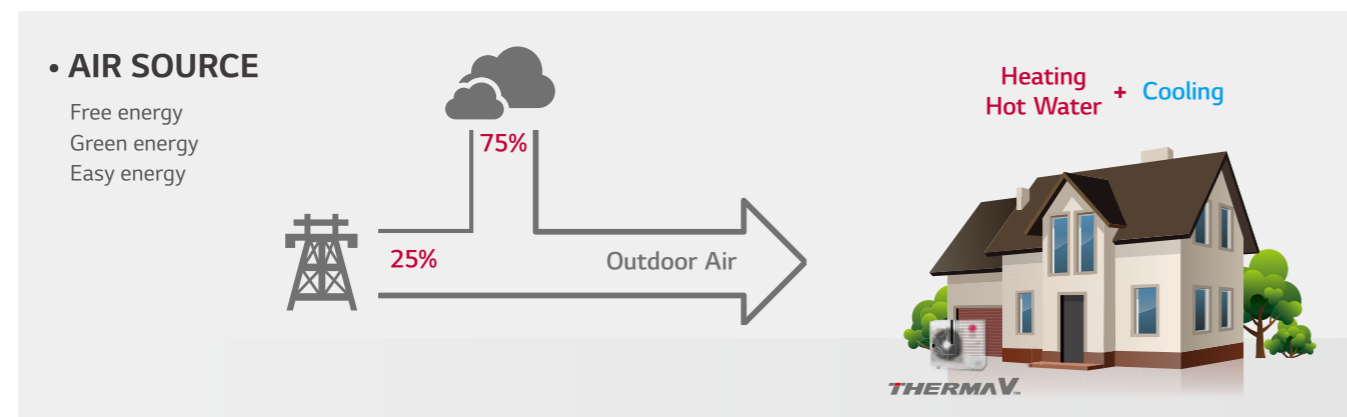

## Optimal Application

Advanced model selection software enables designers to choose optimal THERMA V model based on the location and environmental factors.

- Model selection screen
- Monthly energy simulation
- Heat load & heat pump capacity
- System comparison chart

## Reliable Application

Heating range for outdoor temperature is down to -20°C and leaving water temperature can reach max. 57°C

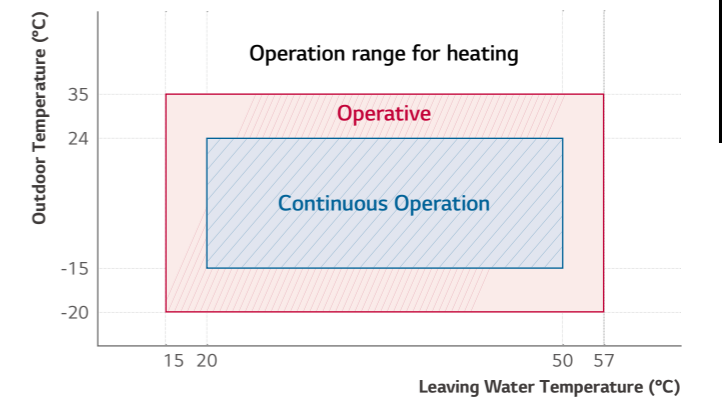

\* In case of Split models

## Various Application

Various kinds of application is possible with THERMA V units including new house also renovation house.

### • New House

With low temp. monobloc & split model, heating and cooling can be ensured.

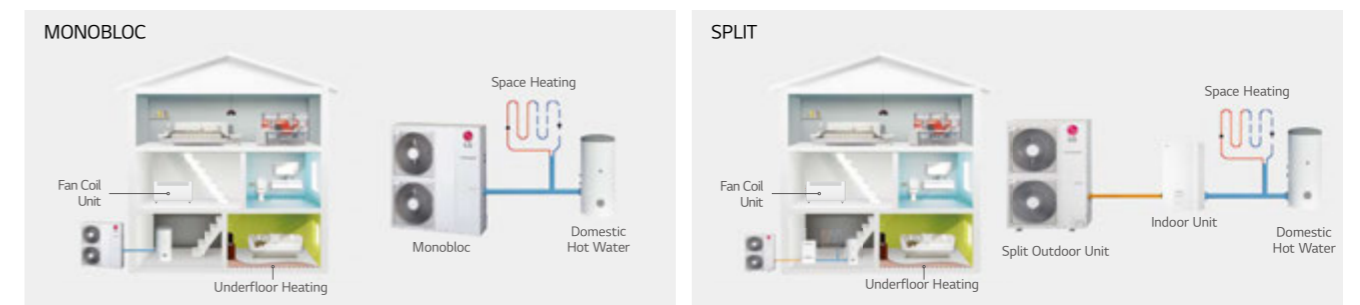

### • Renovation House



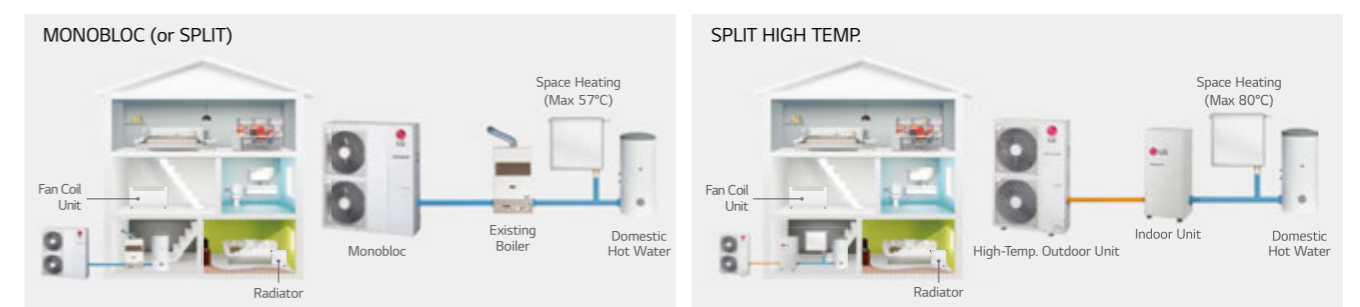









THERMA V can be connected to existing boiler system to optimize energy efficiency and heating capacity for renovation house. Also THERMA V High Temperature can provide equivalent water heating to a boiler of up to 80°C.















# LINE-UP

## THERMA V

TYPE	PHASE	1Ø	1Ø	1Ø	1Ø	1Ø	1Ø	3Ø	3Ø	3Ø
	KW	5	7	9	12	14	16	12	14	16
<b>Monobloc Type</b>   		HM051M.U43	HM071M.U43	HM091M.U43						
					HM121M.U33	HM141M.U33	HM161M.U33	HM123M.U33	HM143M.U33	HM163M.U33
<b>Split Type</b>   		HN1616.NK3	HN1616.NK3	HN1616.NK3						
		HU051.U43	HU071.U43	HU091.U43						
					HN1616.NK3	HN1616.NK3	HN1616.NK3	HN1639.NK3	HN1639.NK3	HN1639.NK3
					HU121.U33	HU141.U33	HU161.U33	HU123.U33	HU143.U33	HU163.U33

TYPE	PHASE	1Ø	1Ø	1Ø	1Ø	1Ø	1Ø	3Ø	3Ø	3Ø
	KW	5	7	9	12	14	16	12	14	16
<b>Split DHW Tank Integrated Type</b>   				HN1616.T.NB0						
				HU091.U43						
					HN1616.T.NB0	HN1616.T.NB0	HN1616.T.NB0	HN1616.T.NB0	HN1616.T.NB0	HN1616.T.NB0
<b>Split High Temp. Type</b>    							HN1610H.NK2			
							HU161H.U32			

HEATING

\* A+++ label is available from 26, Sep. 2019 and should be considered as A++ label until that time.

# LG THERMA V



## Why LG THERMA V?

The LG THERMA V is designed to provide reasonable benefits such as like energy saving, comforts, easy controls and services by applying the advanced technologies.

The LG Inverter Technology provides excellent energy efficiency with optimal components such as water pump, heat exchanger and fan motor. Moreover, the pressure control technology provides stable heating capacity at a low temperature and reaches target performance without difficulties.

Additionally, the amalgamated model where all-in-one features are combined such as gold-fin and users-oriented functions. This has resulted in boosting professional reputation and enhancing end-user's experience in the form of LG's full line-up from 5kW to 16kW in heating capacity.

# MONOBLOC



R32  
MONOBLOC

## THERMA V KEY FEATURES

# MONOBLOC

## R1 Scroll Compressor

Revolutionary Scroll Compressor is applied for high-efficiency and reliability. This type of compressor is more advanced compressor compared to the conventional scroll compressor, especially tilting motion of scroll has been improved. Further, compressor operation range is improved compared to previous model.

### • Revolutionary Scroll Compressor

- Scroll compressor with simple structure
- High efficiency (low load at low speed / total efficiency)
- Low noise (high speed possible)
- Improved Tilting Motion of scroll
- 20% weight reduction (vs. conventional compressor)

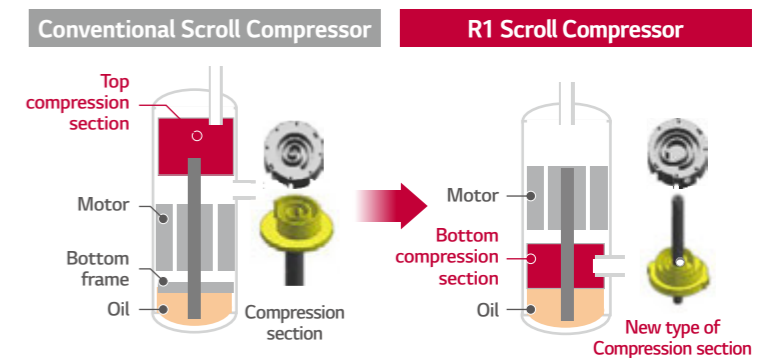

## Flash Gas Injection

In case of R32 Refrigerant, it is very important to control discharge temperature of compressor properly. In the R32 Monobloc, Flash Gas Injection technology is applied to control discharge temperature of compressor efficiently. As a result of this technology, heating operation range is expanded and heating performance at low ambient temperature is enhanced.

### • Vapor Injection

- Discharge Temperature of Compressor is very high (160°C)
- Failure of Injection Cycle and compressor operation under protection logic

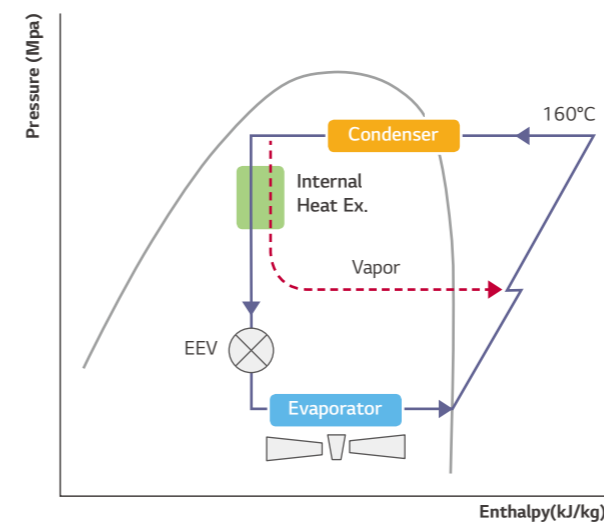

### • Flash Gas Injection

- Discharge Temperature of Compressor is below 110°C
- Good Operation of Injection Cycle

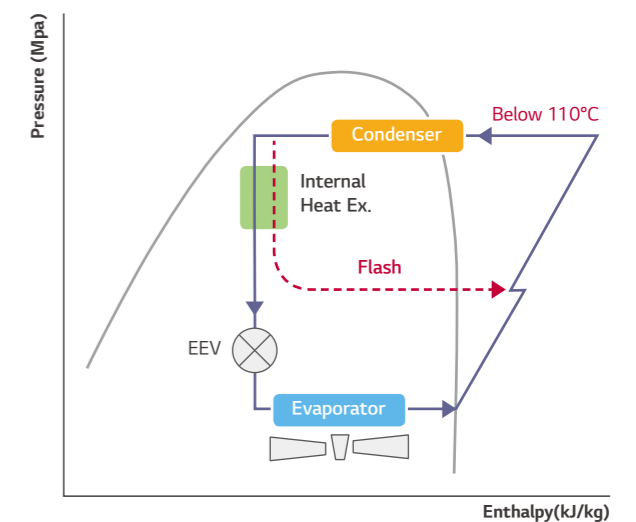

HEATING

# MONOBLOC

## Intuitive Interface

The R32 Monobloc system is upgraded with new remote controller.



### • Premium Design

New Modern design 4.3 inch color LCD display  
Capacitive touch button (especially on/off button turn on LED)

### • User Friendly Interface

Information displayed with simple graphic, icon & text  
Navigation button, easy to use

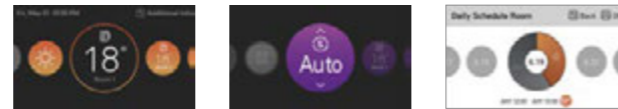

### • More energy contents

Auto controlled by weather and time

### • Convenient Functions

Optimize schedule setting logic  
• Set the period, date, on/off time, operation mode, target temp  
Easy installation setting ( as-is : numeric code , to-be : word)

## Seasonal Auto Mode

In this mode, the target temperature will vary according to the outdoor temperature automatically.  
This mode adds the cooling season function to the conventional weather dependent operation mode.

	Auto-Adjustable Target Temp.	Leaving Water Temp.	Outdoor Air Temp.	
Heating	Water 1 Heat	15 - 57	Outdoor 1 Heat	-15 - 24
	Water 2 Heat	15 - 57	Outdoor 2 Heat	-15 - 24
Cooling	Water 3 Cool	5 - 25	Outdoor 3 Cool	10 - 43
	Water 4 Cool	5 - 25	Outdoor 4 Cool	10 - 43

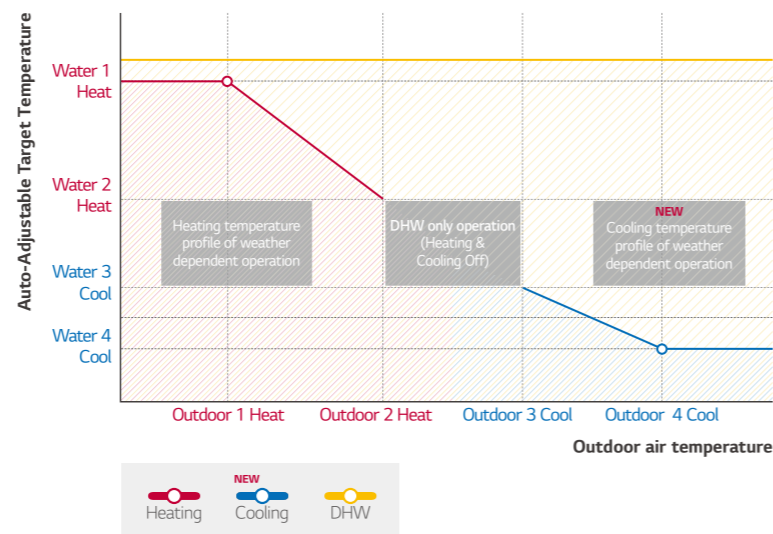

## Various Temperature Control Options

Various Temperature Control Options are possible for the User's comfort and convenience. Especially for European life style where thermal comfort is preferred, Simultaneous Control of Room Air and Water Temp. function is added.

- ① Control of Leaving Water Temperature
- ② Control of Entering Water Temperature
- ③ Control of Room Air Temperature
- ④ Simultaneous Control of Room Air and Water Temp.

- Thermo On : When Satisfied both Room Air Temp. Condition and Water Temp. Condition
- Thermo Off : When Satisfied Room Air Temp. Condition or Water Temp. Condition

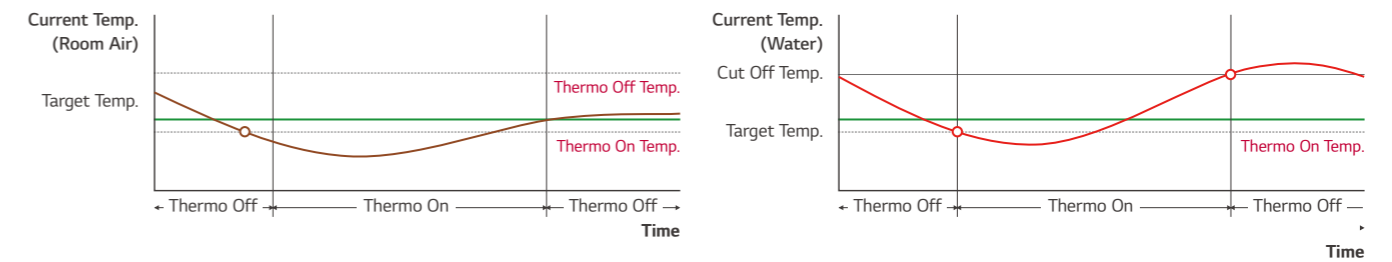

## Ocean Black Fin

'Ocean Black Fin' heat exchanger is highly corrosion resistant, designed to perform in corrosive environment such as contaminated and humid conditions.



Longer Lifespan,  
Lower Operational Costs



Strengthened corrosion  
resistant coating

### Hydrophilic Film (Water Flow)

The Hydrophilic coating minimizes moisture buildup on the fin.

### Epoxy Resin (Corrosion resistant)

The Black coating provides strong protection from corrosion

### Aluminum Fin

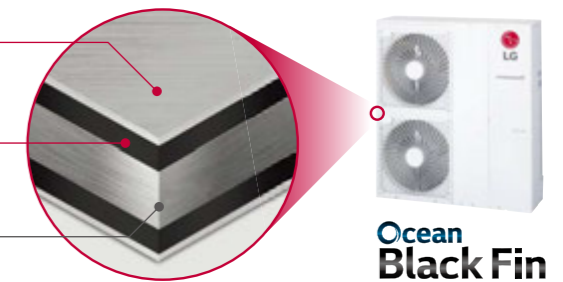

## Easy Installation

### • All-in-one Concept

- LG provides fully packaged THERMA V Monobloc that additional water side components are included in the package.
- No need to work refrigerant piping, easier and quicker installation.



### Water side Items included in the Monobloc

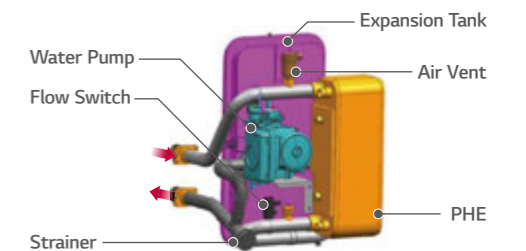
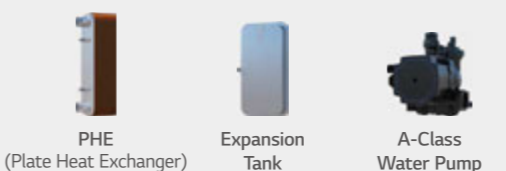

THERMA V SPECIFICATION  
**MONOBLOC**



HM051M.U43 / HM071M.U43 / HM091M.U43



DESCRIPTION		UNIT	HM051M.U43	HM071M.U43	HM091M.U43
<b>SEASONAL ENERGY</b>					
Space Heating (According to EN14825)	Average Climate water outlet 35°C	SCOP	4.45	4.45	4.45
		Rated heat output (Prated)	6	6	6
		Seasonal space heating efficiency (ηs) %	175	175	175
		Seasonal space heating eff. Class	A+++	A+++	A+++
		Annual energy consumption kWh	2,551	2,668	2,784
	Average Climate water outlet 55°C	SCOP	3.12	3.12	3.12
		Rated heat output (Prated)	6	6	6
		Seasonal space heating efficiency (ηs) %	122	122	122
		Seasonal space heating eff. Class	A+	A+	A+
		Annual energy consumption kWh	3,638	3,638	3,638

**PRODUCT SPECIFICATION**

DESCRIPTION		UNIT	HM051M.U43	HM071M.U43	HM091M.U43		
Nominal Capacity	Heating	OAT	LWT				
		7°C	35°C	kW	5.50	7.00	9.00
		7°C	55°C	kW	5.50	5.50	5.50
	Cooling	2°C	35°C	kW	3.30	4.20	5.40
		35°C	18°C	kW	5.50	7.00	9.00
		35°C	7°C	kW	5.50	7.00	9.00
Nominal Power Input	Heating	7°C	35°C	kW	1.22	1.56	2.15
		7°C	55°C	kW	2.04	2.04	2.04
		2°C	35°C	kW	0.94	1.20	1.54
	Cooling	35°C	18°C	kW	1.20	1.56	2.14
		35°C	7°C	kW	1.96	2.59	3.46
		7°C	35°C	W/W	4.50	4.50	4.18
COP	Heating	7°C	55°C	W/W	2.70	2.70	2.70
		2°C	35°C	W/W	3.52	3.51	3.50
		35°C	18°C	W/W	4.60	4.50	4.20
EER	Cooling	35°C	7°C	W/W	2.80	2.70	2.60
		35°C	7°C	W/W			
Operation range	Heating	Water Side Min - Max (outlet) °C		15 - 65			
		Air Side Min-Max °C		-25 - 35			
	Cooling	Water Side Min - Max (outlet) °C		5 - 27			
		Air Side Min-Max °C		5 - 48			
Refrigerant	Domestic Hot Water Water Side Min - Max (outlet) °C			15 - 80			
	Type			R32			
	GWP (Global Warming Potential)			675			
	Charge	kg		1.4			
Compressor	Quantity			1			
	Type			Scroll			
Water Flow Rate	Min.	LPM		15			
Piping Connections	Water Inlet	mm(in)		Male PT 25(1)			
	Circuit Outlet	mm(in)		Male PT 25(1)			
Dimensions	Unit	W x H x D		1,239 x 834 x 330			
Net Weight	Unit	kg		91			
Sound Pressure Level (at 1m)	Heating	Rated		50			
		Rated		60			
Power supply	Phase / Frequency / Voltage	∅ / Hz / V		1 / 50 / 220-240			
		Maximum Running Current	A	23			

- Note
1. A+++ label is available from 26, Sep. 2019 and should be considered as A++ label until that time.
  2. Due to our policy of innovation some specifications may be changed without notification.
  3. Wiring cable size must comply with the applicable local and national codes. And "Electric characteristics" chapter should be considered for electrical work and design. Especially the power cable and circuit breaker should be selected in accordance with that.
  4. Sound pressure level is measured on the rated condition in the anechoic rooms by ISO 3745 standard. Sound power level is measured on the rated condition in the reverberation rooms by ISO 3741 standard. Therefore, these values can be increased owing to ambient conditions during operation.
  5. Performances are accordance with EN14511. 6. This product contains Fluorinated greenhouse gases. 7. LWT : Leaving Water Temperature, OAT : Outdoor Air Temperature

HM121M.U33 / HM141M.U33 / HM161M.U33  
HM123M.U33 / HM143M.U33 / HM163M.U33



DESCRIPTION		UNIT	HM121M.U33	HM141M.U33	HM161M.U33	HM123M.U33	HM143M.U33	HM163M.U33
<b>SEASONAL ENERGY</b>								
Space Heating (According to EN14825)	Average Climate water outlet 35°C	SCOP	4.45	4.45	4.45	4.45	4.45	4.45
		Rated heat output (Prated)	10	11	11	10	11	11
		Seasonal space heating efficiency (ηs) %	175	175	175	175	175	175
		Seasonal space heating eff. Class	A+++	A+++	A+++	A+++	A+++	A+++
		Annual energy consumption kWh	4,642	4,875	5,103	4,642	4,875	5,103
	Average Climate water outlet 55°C	SCOP	3.18	3.18	3.18	3.18	3.18	3.18
		Rated heat output (Prated)	12	12	12	12	12	12
		Seasonal space heating efficiency (ηs) %	124	124	124	124	124	124
		Seasonal space heating eff. Class	A+	A+	A+	A+	A+	A+
		Annual energy consumption kWh	7,795	7,795	7,795	7,795	7,795	7,795

**PRODUCT SPECIFICATION**

DESCRIPTION		UNIT	HM121M.U33	HM141M.U33	HM161M.U33	HM123M.U33	HM143M.U33	HM163M.U33		
Nominal Capacity	Heating	OAT	LWT							
		7°C	35°C	kW	12.00	14.00	16.00	12.00	14.00	16.00
		7°C	55°C	kW	12.00	12.00	12.00	12.00	12.00	12.00
	Cooling	2°C	35°C	kW	11.00	12.00	13.80	11.00	12.00	13.80
		35°C	18°C	kW	14.00	14.00	16.00	14.00	14.00	16.00
		35°C	7°C	kW	14.00	14.00	16.00	14.00	14.00	16.00
Nominal Power Input	Heating	7°C	35°C	kW	2.61	3.11	4.00	2.61	3.11	4.00
		7°C	55°C	kW	4.29	4.29	4.29	4.29	4.29	4.29
		2°C	35°C	kW	3.13	3.42	3.94	3.13	3.42	3.94
	Cooling	35°C	18°C	kW	3.04	3.26	4.00	3.04	3.26	4.00
		35°C	7°C	kW	5.19	5.38	6.40	5.19	5.38	6.40
		7°C	35°C	W/W	4.60	4.50	4.00	4.60	4.50	4.00
COP	Heating	7°C	55°C	W/W	2.80	2.80	2.80	2.80	2.80	2.80
		2°C	35°C	W/W	3.52	3.51	3.50	3.52	3.51	3.50
		35°C	18°C	W/W	4.60	4.30	4.00	4.60	4.30	4.00
EER	Cooling	35°C	7°C	W/W	2.70	2.60	2.50	2.70	2.60	2.50
		35°C	7°C	W/W						
Operation range	Heating	Water Side Min - Max (outlet) °C		15 - 65						
		Air Side Min-Max °C		-25 - 35						
	Cooling	Water Side Min - Max (outlet) °C		5 - 27						
		Air Side Min-Max °C		5 - 48						
Domestic Hot Water Water Side Min - Max (outlet) °C			15 - 80							
Refrigerant	Type			R32						
	GWP (Global Warming Potential)			675						
	Charge		kg	2.4	2.4					
			tCO <sub>2</sub> eq	1.62	1.62					
Compressor	Quantity			1						
	Type			Scroll						
Water Flow Rate	Min.	LPM		20						
Piping Connections	Water Inlet	mm(in)		Male PT 25(1)						
	Circuit Outlet	mm(in)		Male PT 25(1)						
Dimensions	Unit	W x H x D		1,239 x 1,380 x 330						
Net Weight	Unit	kg		125						
Sound Pressure Level (at 1m)	Heating	Rated		52						
		Rated		63						
Power supply	Phase / Frequency / Voltage	∅ / Hz / V		1 / 50 / 220-240						
		Maximum Running Current	A	35						

- Note
1. Due to our policy of innovation some specifications may be changed without notification.
  2. Wiring cable size must comply with the applicable local and national codes. And "Electric characteristics" chapter should be considered for electrical work and design. Especially the power cable and circuit breaker should be selected in accordance with that.
  3. Sound pressure level is measured on the rated condition in the anechoic rooms by ISO 3745 standard. Sound power level is measured on the rated condition in the reverberation rooms by ISO 3741 standard. Therefore, these values can be increased owing to ambient conditions during operation.
  4. Performances are accordance with EN14511.
  5. This product contains Fluorinated greenhouse gases. 6. LWT : Leaving Water Temperature, OAT : Outdoor Air Temperature

# SPLIT



## THERMA V KEY FEATURES

# SPLIT

## BLDC (Brushless Direct Current Motor) Compressor

THERMA V is equipped with a BLDC compressor that uses a strong neodymium magnet. The compressor has improved efficiency compared to standard AC inverter product and it is optimized for seasonal efficiency.

- Minimized oil circulation
- High efficiency motor
- Optimized compression
- Optimized vibration, noise
- High reliability



HEATING

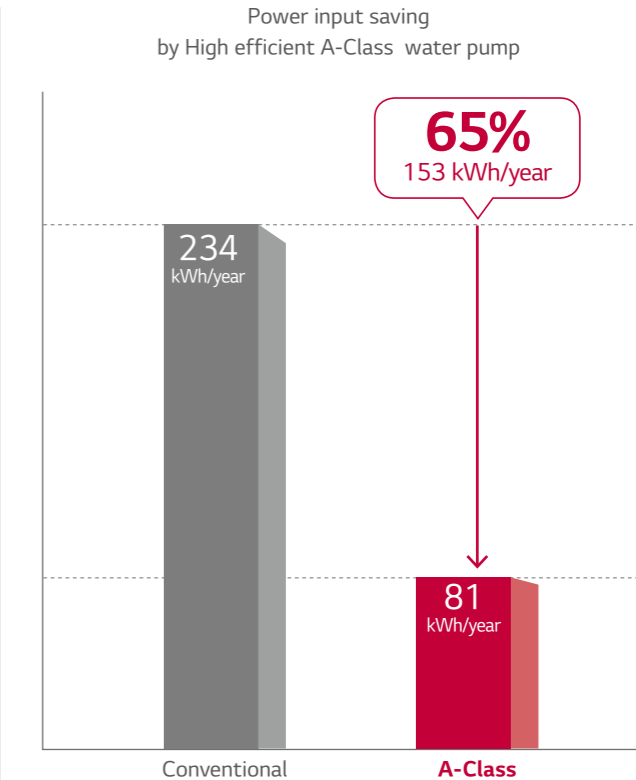
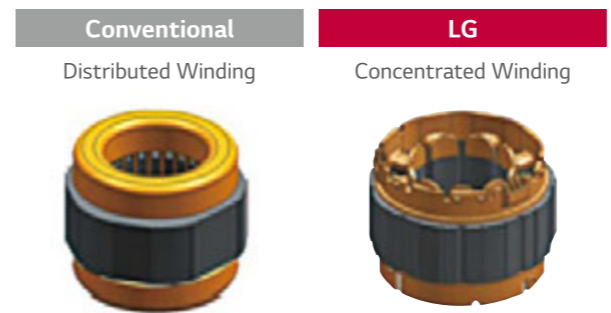
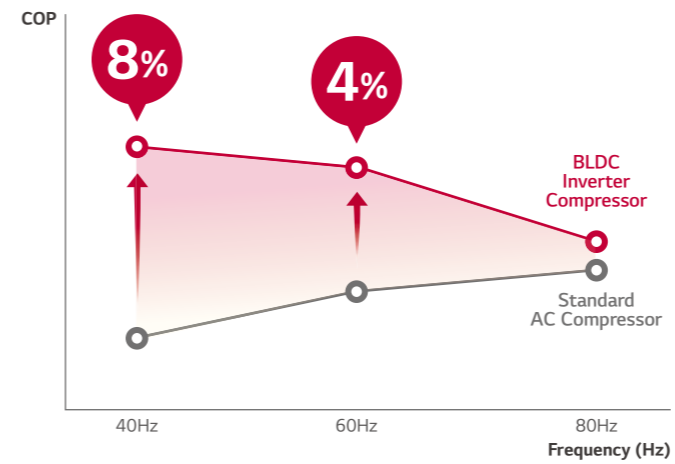

\* Condition : 12 hours x 30 days x 5 month (estimated value)

# SPLIT

## Reliability at Low Temperature

Pressure control reinforces heating performance by operating in stable condition at low ambient temperature.

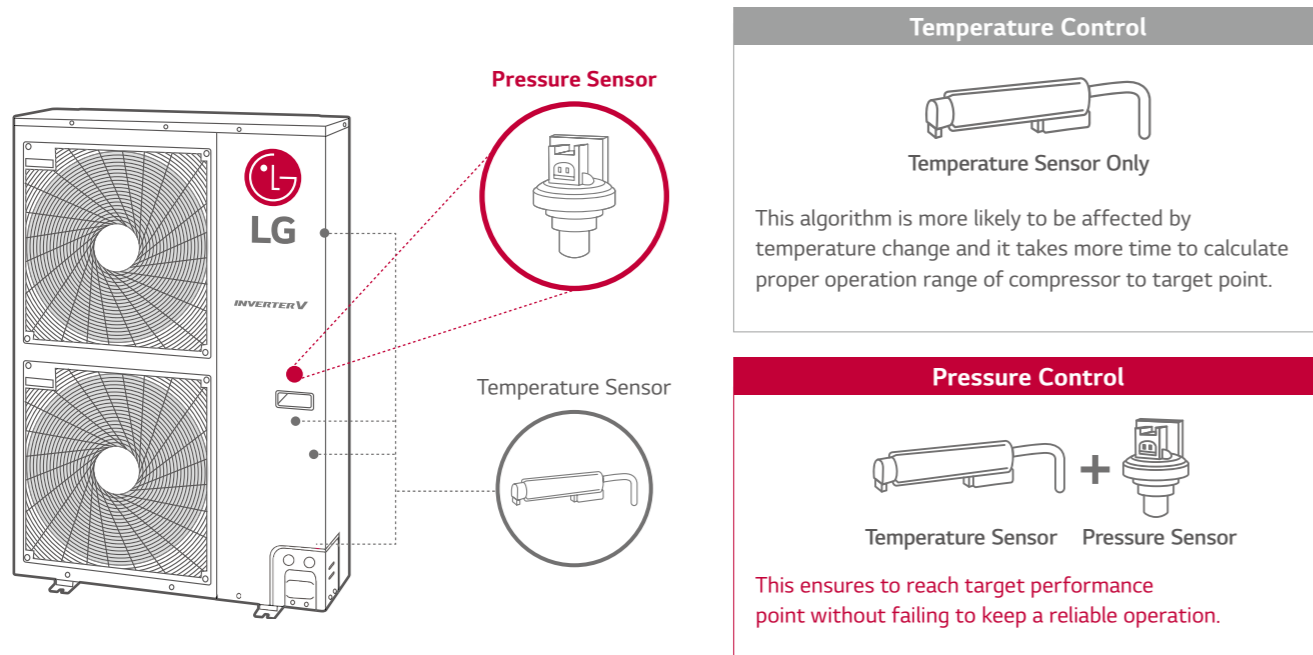

## Easy Commissioning

### • Pre-Installation Setting

- Based on installation site information, installers can prepare presetting with LG Heating Configurator and save data into memory card from office.
- At the site, then installers can simply insert memory card at the back of remote controller to activate configuration data.



## Emergency Operation

Even in case of sudden product error, THERMA V ensures stable heating operation by applying 2 steps of emergency control.

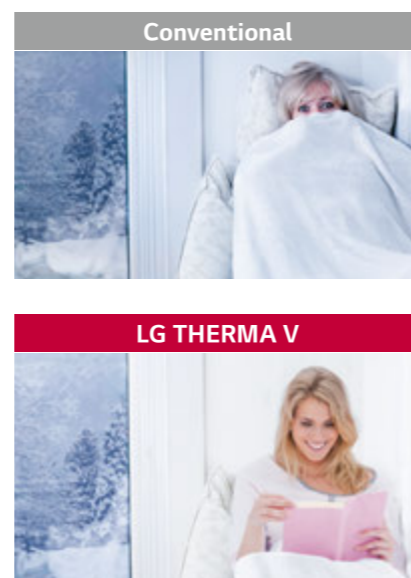

## Easy & Quick Maintenance

### • Data Logging

- The remote controller can store up to 50 history items, making it possible to easily identify cause of malfunctioning or faults using the history data and prompt solution



- Date and time
- Operation mode (Cooling, Heating, Hot Water, Auto)
- Setting temperature
- Inlet / Outlet temperature
- Room air temperature
- DHW (Operation status / Target temperature / current temperature)
- ODU operation status
- Error status & code

## HN1616.NK3 / HU051.U43, HU071.U43, HU091.U43



LG participates in the ECP programme for EUROVENT EURO-HP program. Check ongoing validity of certification : www.eurovent-certification.com



DESCRIPTION		ODU	HU051.U43	HU071.U43	HU091.U43
		IDU	HN1616.NK3		
<b>SEASONAL ENERGY</b>					
Space Heating (According to EN14825)	Average	SCOP	4.52	4.45	4.34
	Climate water outlet 35°C	Rated heat output (Prated)	6	7	7
		Seasonal space heating efficiency (ηs) %	178	175	171
	Annual energy consumption	Seasonal space heating eff. Class	A+++	A+++	A++
		SCOP	2,512	2,783	3,093
	Average	Rated heat output (Prated)	6	6	6
Climate water outlet 55°C	Seasonal space heating efficiency (ηs) %	126	126	126	
	Seasonal space heating eff. Class	A++	A++	A++	
	Annual energy consumption	3,581	3,581	3,581	

### PRODUCT SPECIFICATION

DESCRIPTION		UNIT	HU051.U43	HU071.U43	HU091.U43	
Nominal Capacity	Heating	OAT 7°C	5.00	7.00	9.00	
		LWT 35°C	4.30	5.97	7.30	
	Cooling	2°C	6.24	6.68	7.08	
		35°C	4.23	5.88	7.53	
Nominal Power Input	Heating	35°C	5.00	7.00	9.00	
		7°C	1.01	1.59	2.05	
	Cooling	2°C	3.52	1.70	2.09	
		35°C	3.20	3.34	3.54	
COP	Heating	2°C	2.78	2.14	2.74	
		35°C	1.09	1.56	2.37	
	Cooling	7°C	4.93	4.80	4.40	
		35°C	3.52	3.51	3.50	
EER	Heating	2°C	1.95	2.00	2.00	
		35°C	2.78	2.75	2.75	
	Cooling	7°C	4.60	4.50	3.80	
		35°C	-	-	-	
Operation Range (Outdoor Air)	Heating	Min. - Max.	-20 - 35	5 - 48	-20 - 35	
		°C DB	-	-	-	
	Cooling	Min. - Max.	-	-	-	
		°C DB	-	-	-	
Refrigerant	Charge	Type	R410A	R410A	R410A	
		GWP (Global Warming Potential)	2,088	2,088	2,088	
	Chargeless Pipe Length	kg	1.8	3.76	4.8	
		tCO <sub>2</sub> eq	7.5	40	40	
Compressor	Quantity	EA	1	1	1	
		Type	Rotary	Rotary	Rotary	
	Outer Dia.	Liquid	mm(in)	Ø 9.52 (3/8)	Ø 9.52 (3/8)	Ø 9.52 (3/8)
		Gas	mm(in)	Ø 15.88 (5/8)	Ø 15.88 (5/8)	Ø 15.88 (5/8)
Refrigerant Piping Connection	Length	Min.	3	3	3	
		Standard	7.5	7.5	7.5	
	Level Difference (ODU - IDU)	Max.	50	50	50	
		Max.	30	30	30	
Dimensions	Unit	W x H x D	950 x 834 x 330	950 x 834 x 330	950 x 834 x 330	
	Weight	kg	59	59	59	
Sound Power Level	Heating	Rated	65	65	66	
		Phase / Frequency / Voltage	Ø / Hz / V	1 / 50 / 220-240	1 / 50 / 220-240	3 / 50 / 380-415
Power Supply	Maximum Running Current	A	19.0	19.0	16	
		Recommended Circuit Breaker	A	30	30	20

- Note : 1. Due to our policy of innovation some specifications may be changed without notification.  
 2. Wiring cable size must comply with the applicable local and national codes. And "Electric characteristics" chapter should be considered for electrical work and design. Especially the power cable and circuit breaker should be selected in accordance with that.  
 3. Sound Level Values are measured at Anechoic chamber. Therefore, these values depend on the ambient conditions and values are normally higher in actual operation.  
 4. Performances are based on that Interconnected Pipe Length is standard length and difference of Elevation (Outdoor - Indoor Unit) is Zero.  
 5. This product contains Fluorinated greenhouse gases. 6. LWT : Leaving Water Temperature, OAT : Outdoor Air Temperature

DESCRIPTION		UNIT	HN1616.NK3	
Operation Range (Leaving Water)	Heating	°C	15 - 57	
	Cooling	For Fan Coil Unit	°C	6 - 30
		For under floor	°C	16 - 30
Electric Heater	Power supply	Phase / Frequency / Voltage	1 / 50 / 220-240	
	Number of Heating Coil	EA	2	
	Capacity	kW	3 + 3	
	Maximum Running Current	A	32	
Water Flow Rate	Min.	LPM	15	
	Water Circuit	Inlet / Outlet	Male PT 25(1) / Male PT 25(1)	
Connections	Refrigerant Circuit	Gas / Liquid	Ø 15.88 (5/8) / Ø 9.52 (3/8)	
	Body	W x H x D	490 x 850 x 315	
Net Weight	Body	kg	43	
	Sound power level	Heating	Rated	44

## HN1616.NK3 / HU121.U33, HU141.U33, HU161.U33 HN1639.NK3 / HU123.U33, HU143.U33, HU163.U33



LG participates in the ECP programme for EUROVENT EURO-HP program. Check ongoing validity of certification : www.eurovent-certification.com



DESCRIPTION		ODU	HU121.U33	HU141.U33	HU161.U33	HU123.U33	HU143.U33	HU163.U33
		IDU	HN1616.NK3	HN1616.NK3	HN1616.NK3	HN1639.NK3	HN1639.NK3	HN1639.NK3
<b>SEASONAL ENERGY</b>								
Space Heating (According to EN14825)	Average	SCOP	4.45	4.45	4.30	4.45	4.45	4.30
	Climate water outlet 35°C	Rated heat output (Prated)	9	10	9	9	10	10
		Seasonal space heating efficiency (ηs) %	175	175	169	175	175	169
	Annual energy consumption	Seasonal space heating eff. Class	A+++	A+++	A++	A+++	A+++	A++
		SCOP	4,177	4,408	4,802	4,177	4,408	4,802
	Average	Rated heat output (Prated)	10	10	10	10	10	10
Climate water outlet 55°C	Seasonal space heating efficiency (ηs) %	130	130	130	130	130	130	
	Seasonal space heating eff. Class	A++	A++	A++	A++	A++	A++	
	Annual energy consumption	6,154	6,154	6,154	6,154	6,154	6,154	

### PRODUCT SPECIFICATION

DESCRIPTION		UNIT	HU121.U33	HU141.U33	HU161.U33	HU123.U33	HU143.U33	HU163.U33
Nominal Capacity	Heating	OAT 7°C	12.00	14.00	16.00	12.00	14.00	16.00
		LWT 35°C	10.33	10.83	11.95	10.33	10.83	11.95
	Cooling	2°C	11.89	11.89	11.89	11.89	11.89	11.89
		35°C	11.00	12.50	13.50	11.00	12.50	13.50
Nominal Power Input	Heating	35°C	12.00	14.00	16.00	12.00	14.00	16.00
		7°C	2.64	3.17	3.76	2.64	3.17	3.76
	Cooling	2°C	2.93	3.09	3.41	2.93	3.09	3.41
		35°C	5.25	5.25	5.25	5.25	5.25	5.25
COP	Heating	2°C	3.14	3.73	4.35	3.14	3.73	4.35
		35°C	2.60	3.08	3.60	2.60	3.08	3.60
	Cooling	7°C	4.55	4.41	4.26	4.55	4.41	4.26
		35°C	3.52	3.51	3.50	3.52	3.51	3.50
EER	Heating	2°C	2.27	2.27	2.27	2.27	2.27	2.27
		35°C	3.50	3.35	3.10	3.50	3.35	3.10
	Cooling	7°C	4.00	3.90	3.61	4.00	3.90	3.61
		35°C	-	-	-	-	-	-
Operation Range (Outdoor Air)	Heating	Min. - Max.	5 - 48	5 - 48	5 - 48	5 - 48	5 - 48	
		°C DB	-	-	-	-	-	-
	Cooling	Min. - Max.	-20 - 35	-20 - 35	-20 - 35	-20 - 35	-20 - 35	
		°C DB	-	-	-	-	-	
Refrigerant	Charge	Type	R410A	R410A	R410A	R410A	R410A	
		GWP (Global Warming Potential)	2,088	2,088	2,088	2,088	2,088	
	Chargeless Pipe Length	kg	2.3	4.8	7.5	2.3	4.8	
		tCO <sub>2</sub> eq	7.5	40	40	7.5	40	
Compressor	Quantity	EA	1	1	1	1	1	
		Type	Rotary	Rotary	Rotary	Rotary	Rotary	
	Outer Dia.	Liquid	mm(in)	Ø 9.52 (3/8)	Ø 9.52 (3/8)	Ø 9.52 (3/8)	Ø 9.52 (3/8)	
		Gas	mm(in)	Ø 15.88 (5/8)	Ø 15.88 (5/8)	Ø 15.88 (5/8)	Ø 15.88 (5/8)	
Refrigerant Piping Connection	Length	Min.	3	3	3	3		
		Standard	7.5	7.5	7.5	7.5		
	Level Difference (ODU - IDU)	Max.	50	50	50	50		
		Max.	30	30	30	30		
Dimensions	Unit	W x H x D	950 x 1,380 x 330	950 x 1,380 x 330	950 x 1,380 x 330	950 x 1,380 x 330		
	Weight	kg	94	94	94	94		
Sound Power Level	Heating	Rated	66	66	66	66		
		Phase / Frequency / Voltage	Ø / Hz / V	1 / 50 / 220-240	1 / 50 / 220-240	3 / 50 / 380-415	3 / 50 / 380-415	
Power Supply	Maximum Running Current	A	25	25	16	20		
		Recommended Circuit Breaker	A	40	40	20		

- Note : 1. Due to our policy of innovation some specifications may be changed without notification.  
 2. Wiring cable size must comply with the applicable local and national codes. And "Electric characteristics" chapter should be considered for electrical work and design. Especially the power cable and circuit breaker should be selected in accordance with that.  
 3. Sound Level Values are measured at Anechoic chamber. Therefore, these values depend on the ambient conditions and values are normally higher in actual operation.  
 4. Performances are based on that Interconnected Pipe Length is standard length and difference of Elevation (Outdoor - Indoor Unit) is Zero.  
 5. This product contains Fluorinated greenhouse gases. 6. LWT : Leaving Water Temperature, OAT : Outdoor Air Temperature

DESCRIPTION		UNIT	HN1616.NK3	HN1639.NK3	
Operation Range (Leaving Water)	Heating	°C	15 - 57	15 - 57	
	Cooling	For Fan Coil Unit	°C	6 - 30	6 - 30
		For under floor	°C	16 - 30	16 - 30
Electric Heater	Power supply	Phase / Frequency / Voltage	1 / 50 / 220-240	3 / 50 / 380-415	
	Number of Heating Coil	EA	2	3	
	Capacity	kW	3 + 3	3 + 3 + 3	
	Maximum Running Current	A	32	20	
Water Flow Rate	Min.	LPM	15	15	
	Water Circuit	Inlet / Outlet	Male PT 25(1) / Male PT 25(1)	Male PT 25(1) / Male PT 25(1)	
Connections	Refrigerant Circuit	Gas / Liquid	Ø 15.88 (5/8) / Ø 9.52 (3/8)	Ø 15.88 (5/8) / Ø 9.52 (3/8)	
	Body	W x H x D	490 x 850 x 315	490 x 850 x 315	
Net Weight	Body	kg	43	45	
	Sound power level	Heating	Rated	44	



# DHW TANK INTEGRATED

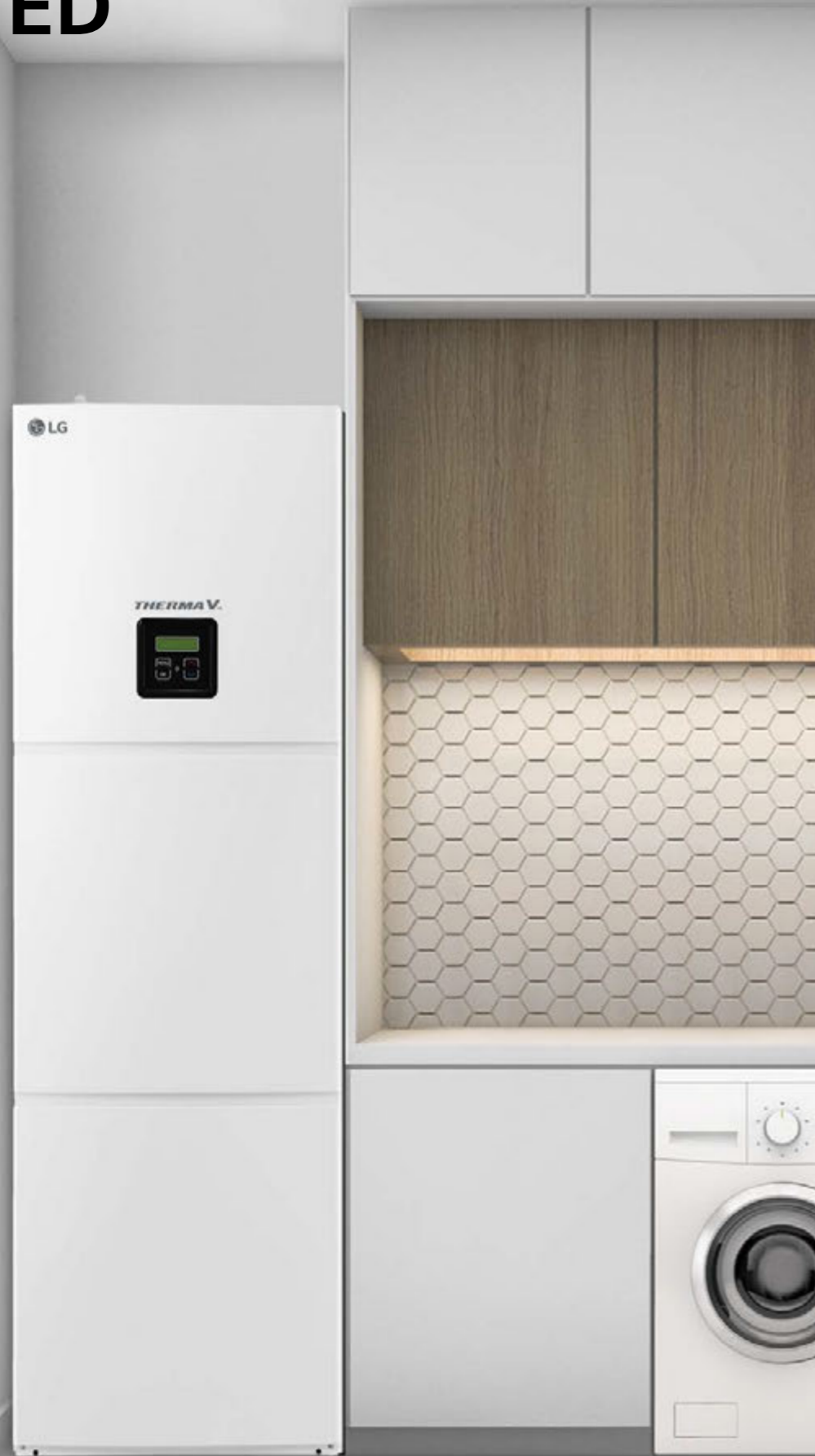

THERMA V KEY FEATURES

## SPLIT DHW TANK INTEGRATED

### Save space & Save time

Compared with conventional system, easy & quick installation is possible and smaller spaces are required for installation.

Conventional	New (DHW tank integrated type)
<ul style="list-style-type: none"> <li>- Enough rooms for product installation</li> <li>- Need to secure the space for water tank</li> <li>- More water piping work &amp; More installation time</li> </ul>	<ul style="list-style-type: none"> <li><b>All in one</b> Small space for product installation</li> <li><b>Less water piping work</b> More easy &amp; Save time</li> </ul>

### 2nd Heating Circuit

Possible heating individually through separate heating circuits with a controller and a mixing valve.

Conventional	New
<p><b>Only 1 heating circuit</b> not individually controllable</p>	<p><b>Basically 2 heating circuits</b> with individual control</p> <p>With the circuit extension module, <b>max 4 heating circuits</b> to control individually (Optional)</p>

### Controller for convenient control

Easy & convenient setting room temperature!

Default controller installed	Option controller installed
<p>Must move to control</p>	<p>It is not required to move it once it has been set up in your room.</p> <p><b>Room controller</b> Thermostat without display Basic settings of room temperature</p> <p>(Optional Accessory: OSHI-REMT01.ENCXLEU)</p>

HEATING

# SPLIT DHW TANK INTEGRATED



HN1616T.NBO



HN1616T.NBO / HU091.U43, HU121.U33, HU141.U33, HU161.U33, HU123.U33, HU143.U33, HU163.U33



HEATING

DESCRIPTION		UNIT	HN1616T.NBO		
<b>PRODUCT SPECIFICATION</b>					
Operation Range (Leaving Water)	Heating	°C	25 - 58		
	Cooling	°C	7 - 25		
	Domestic Hot Water	°C	10 - 60		
Electric Heater	Power supply	Phase / Frequency / Voltage	1 / 50 / 220-240		
	Number of Heating Coil	EA	1		
	Capacity	kW	2		
	Maximum Running Current	A	11.1		
	Recommended Circuit Breaker	A	16		
	Water Flow Rate	Min.	LPM	13	
	Piping Connections	Water Circuit	Inlet	mm(in)	Male PT 25(1)
Outlet			mm(in)	Male PT 25(1)	
Refrigerant Circuit		Gas	mm(in)	Ø 15.88 (5/8)	
		Liquid	mm(in)	Ø 9.52 (3/8)	
DHW Tank Water Circuit		Cold Inlet	mm(in)	Male PT 19.05 (3/4)	
		Hot Outlet	mm(in)	Male PT 25 (1)	
DHW Tank	Type		Hydro module with integrated boiler		
	Material		Enameled steel		
	Water Volume	Rated	ℓ	200	
	Internal Thermal Protect limit		°C	95	
	Maximum water pressure limit		bar	10	
	Insulation	Material	-	Polyurethane foam	
		Thickness	-	50	
		Heat loss (for 24hr)	kWh	1.67	
	Buffer Tank	Water Volume	Rated	ℓ	40
		Material		Steel powder coated	
Insulation Material		Closed cell foamed rubber			
Dimensions	Body	W x H x D	mm	607 x 2,079 x 725	
Net Weight	Body		kg	228	
Sound power level	Heating	Rated	dBA	36	

SPLIT (OUTDOOR)		ODU	HU091.U43	HU121.U33	HU141.U33	HU161.U33	HU123.U33	HU143.U33	HU163.U33		
PRODUCT SPECIFICATION		IDU	HN1616T.NBO								
Nominal Capacity	Heating	OAT	LWT								
	Cooling	7°C	35°C	kW	9.0	12.0	14.0	16.0	12.0	14.0	16.0
Nominal Power Input	Heating	7°C	35°C	kW	2.23	2.78	3.43	4.18	2.78	3.43	4.18
	Cooling	35°C	18°C	kW	2.88	3.30	3.53	4.00	3.30	3.53	4.00
COP	Heating	7°C	35°C	W/W	4.04	4.32	4.08	3.83	4.32	4.08	3.83
	Cooling	35°C	18°C	W/W	3.12	3.15	3.12	3.00	3.15	3.12	3.00
Operation Range (Outdoor Air)	Heating	Min. - Max.	°C DB	-20 - 35							
	Cooling	Min. - Max.	°C DB	5 - 48							
Refrigerant	Type	R410A									
	GWP (Global Warming Potential)	2,088									
	Charge	kg	1.8	2.3	2.3	2.3	2.3	2.3	2.3		
	Chargeless Pipe Length	m	3.76	4.8	4.8	4.8	4.8	4.8	4.8		
Compressor	Additional Charging Volume	g/m	40								
	Quantity	EA	1								
	Type	Rotary									
Refrigerant Piping Connection	Outer Dia.	Liquid	mm(in)	Ø 9.52 (3/8)							
		Gas	mm(in)	Ø 15.88 (5/8)							
	Length	Min.	m	3							
		Standard	m	7.5							
		Max.	m	50							
Level Difference (ODU - IDU)	Max.	m	30								
Dimensions	Unit	W x H x D	mm	950x834x330	950x1,380x330	950x1,380x330	950x1,380x330	950x1,380x330	950x1,380x330	950x1,380x330	
Weight	Unit	kg	59	94	94	94	94	94	94		
Sound Power Level	Heating	Rated	dB(A)	65	66	66	66	66	66	66	
	Phase / Frequency / Voltage	Ø / Hz / V	1 / 50 / 220-240	1 / 50 / 220-240	1 / 50 / 220-240	1 / 50 / 220-240	3 / 50 / 380-415	3 / 50 / 380-415	3 / 50 / 380-415		
Power Supply	Maximum Running Current	A	19	25	25	25	16.1	16.1	16.1		
	Recommended Circuit Breaker	A	30	40	40	40	20	20	20		
	Modbus Converter (*Required purchase separately)										
Modbus Converter	Type	-	Gateway PI485								
	Model	-	PP485B00K								

SEASONAL ENERGY		2.88	3	3	3	3	3	3	
Space heating	Average climate water outlet 55°C (A++ to G Scale)	General	SCOP	2.88	3	3	3	3	3
			ηs (Seasonal space heating efficiency) %	112	117	117	117	117	117
	Average climate water outlet 35°C (A++ to G Scale)	General	Seasonal space heating eff. Class	A+	A+	A+	A+	A+	A+
			SCOP	4.04	4.2	4.15	4.15	4.2	4.15
Domestic Hot Water Heating	General	Declared load profile	ηs (Seasonal space heating efficiency) %	159	165	163	163	165	163
			Water heating energy efficiency class	A++	A++	A++	A++	A++	A++
Domestic Hot Water Heating	Average climate (A to G Scale)	ηwh (water heating efficiency) %	Water heating energy efficiency class	XL	XL	XL	XL	XL	XL
				A	A	A	A	A	A

- Note
- Due to our policy of innovation some specifications may be changed without notification.
  - Wiring cable size must comply with the applicable local and national codes. And "Electric characteristics" chapter should be considered for electrical work and design. Especially the power cable and circuit breaker should be selected in accordance with that.
  - Sound Level Values are measured at Anechoic chamber. Therefore, these values depend on the ambient conditions and values are normally higher in actual operation.
  - Performances are based on that Interconnected Pipe Length is standard length and difference of Elevation (Outdoor - Indoor Unit) is Zero.
  - This product contains Fluorinated greenhouse gases.
  - LWT : Leaving Water Temperature, OAT : Outdoor Air Temperature

Notes  
1. Indoor unit is include integrated electrical heater

# DHW TANK INTEGRATED



THERMA V KEY FEATURES

## HIGH TEMPERATURE

### Quick Defrosting

Through R134A compressor controlling technology, necessary time for defrost operation has been minimized effectively. (LG Patent)

As compared to normal reverse cycle defrost, 25% reduction in defrost time, and 10% increase of integrated heating capacity is achieved using hybrid defrosting.

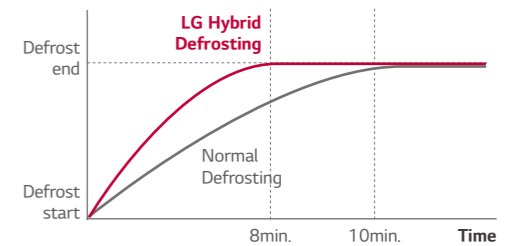
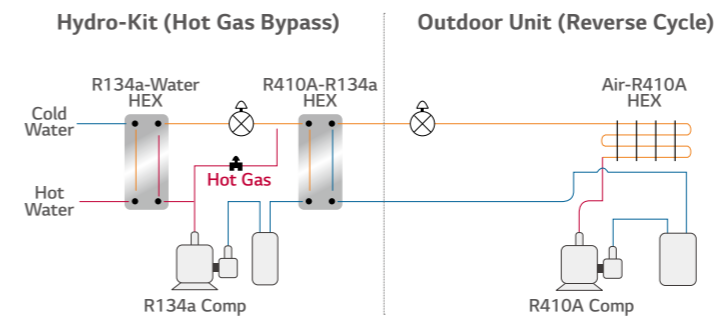

### Higher Energy Efficiency

By applying efficient compressor and optimally designed structure, the more energy saving, the lower operating cost make sooner return on initial investment.

Heating COP at -7°C Outdoor Temperature

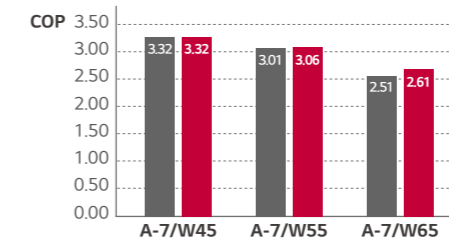

Heating COP at -7°C Outdoor Temperature

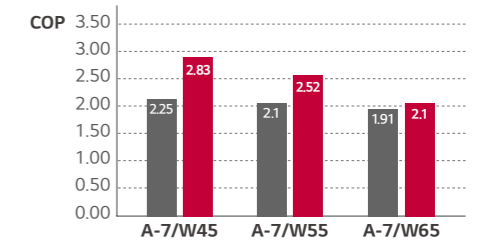

### Low Noise Level

Through cutting edge technology for DC inverter compressor, operating noise level of indoor & outdoor unit has been reduced and serves more comfort.

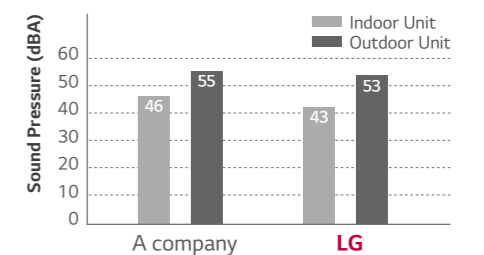

HEATING

# HIGH TEMPERATURE

## Enhanced Efficiency & Performance

THERMA V high temp. can produce Max. 80°C hot water with high efficiency (Max. COP 4.06 at 24°C ODT & 40/45 EWT/LWT) through cascade 2 stage compression technology.

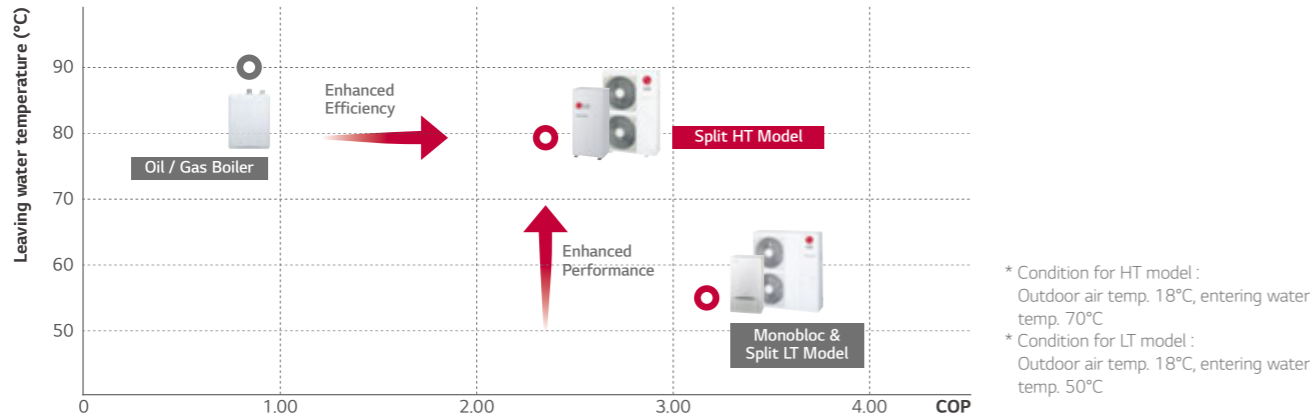

## Cascade 2 Stage Compression Technology

Max. 80°C hot water can be generated through Cascade R410A to R134a BLDC compressor technology and is applicable for existing old boiler heating system which demands hot water supply.

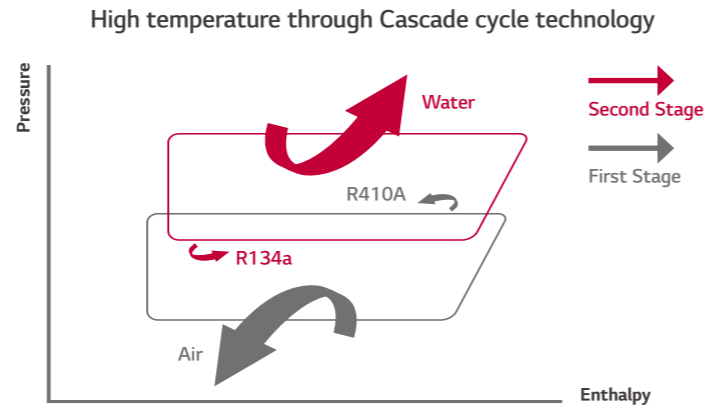

## Low Maximum Current Level

LG High Temperature THERMA V can be easily installed without any incurring any additional costs to the electric connections.

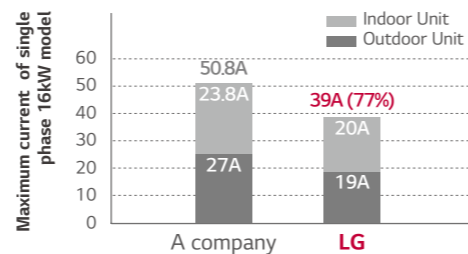

# HIGH TEMPERATURE



HN1610H.NK2  
HU1611H.U32



LG participates in the ECP programme for EUROVENT EURO-HP program. Check ongoing validity of certification : [www.eurovent-certification.com](http://www.eurovent-certification.com)



HEATING

## Product Specification

DESCRIPTION	OUTDOOR UNIT		INDOOR UNIT		HN1611H.U32	HN1610H.NK2
	OAT	LWT				
Nominal Capacity	Heating	7°C	65°C	kW	16,00	
Nominal Power Input	Heating	7°C	65°C	kW	6.13	
COP	Heating	7°C	65°C	W/W	2.61	
Operation Range (Outdoor Air)	Heating	Min. - Max.	°C DB		-20 - 35	
	Cooling	Min. - Max.	°C DB		N/A	
Refrigerant	Type				R410A	
	GWP (Global Warming Potential)				2,088	
	Charge			kg	3.5	
Compressor	Chargeless Pipe Length			tCO <sub>2</sub> ,eq	7.3	
	Additional Charging Volume			m	10	
	Quantity			g/m	60	
Refrigerant Piping Connection	Type			EA	1	
	Outer Dia.	Liquid		mm(in)	Ø 9.52 (3/8)	
		Gas		mm(in)	Ø 15.88 (5/8)	
Dimensions	Min.			m	5	
	Length	Standard		m	7.5	
	Level Difference (ODU - IDU)	Max.		m	50	
Weight	Unit			mm	950 x 1,380 x 330	
	Unit			kg	105	
Sound Power Level	Heating	Rated		dB(A)	5	
	Phase / Frequency / Voltage			Φ / Hz / V	1 / 50 / 220-240	
Power Supply	Maximum Running Current			A	19	
	Recommended Circuit Breaker			A	25	

Note :

- Capacities and power inputs are based on the following conditions:
  - Piping Length : Interconnected Pipe Length = 7.5m
  - Difference Limit of Elevation (Outdoor - Indoor Unit) is Zero.
- Wiring cable size must comply with the applicable local and national codes.

3. Due to our policy of innovation some specifications may be changed without notification.

- Sound Level Values are measured at Anechoic chamber. Therefore, these values can be increased owing to ambient conditions during operation.
- This product contains Fluorinated Greenhouse Gases.
- LWT : Leaving Water Temperature, OAT : Outdoor Air Temperature

## Indoor Unit Specification

DESCRIPTION	UNIT	HN1610H.NK2
Operation Range(Leaving Water)	Heating	°C
Type	R134a	
Refrigerant	GWP (Global Warming Potential)	-
	Charge	kg
Compressor	tCO <sub>2</sub> ,eq	2.3
	Quantity	EA
Water Flow Rate	Type	Rotary
	Min.	LPM
Piping Connections	Min.	15
	Water Circuit	Inlet
	Outlet	mm(in)
	Refrigerant	mm(in)
Dimensions	Gas	mm(in)
	Circuit	Liquid
	Body	mm
	Body	W x H x D
Net Weight	mm	520 x 1,080 x 330
	kg	94
Sound Pressure Level	Heating	Rated
	dB(A)	43
Power Supply	Phase / Frequency / Voltage	Φ / Hz / V
	Maximum Running Current	A
	Recommended Circuit Breaker	A

Note :

- Wiring cable size must comply with the applicable local and national codes.
- Due to our policy of innovation some specifications may be changed without notification.

3. Sound Level Values are measured at Anechoic chamber. Therefore, these values can be increased owing to ambient conditions during operation.

- This product contains Fluorinated Greenhouse Gases (R134a).

# ACCESSORIES



THERMA V SPECIFICATION

## ELECTRIC BACK UP HEATER

HA031M.E1  
HA061M.E1



HEATING

Electrical Specification			HM031M.E1	HA061M.E1
Backup Heater	Type		Sheath	Sheath
	Number of Heating Coil	EA	1	2
	Capacity Combination	kW	3.0	3.0 + 3.0
	Operation		Automatic	Automatic
	Heating Steps	Step	1	2
	Power Supply	V, Ø, Hz	220-240, 1, 50	220-240, 1, 50
	Maximum Current	A	12.0	24.0
Wiring Connections	Power Cable (included Earth, H07RN-F)	No. x mm <sup>2</sup>	3 x 1.5	3 x 4.0
	Communication Cable (H07RN-F)	No. x mm <sup>2</sup>	4 x 0.75	4 x 0.75

Note

1. Due to our policy of innovation some specifications may be changed without notification.
2. Wiring cable size must comply with the applicable local and national codes.

# DOMESTIC HOT WATER TANK

OSHW-200F  
OSHW-300F  
OSHW-500F  
OSHW-300FD



## Domestic Hot Water Tank – Double Coil

DOMESTIC HOT WATER TANK			OSHW-200F	OSHW-300F	OSHW-500F	OSHW-300FD
<b>PRODUCT SPECIFICATION</b>						
General Characteristics	Water Volume	L	200	300	500	300
	Diameter	mm	640	640	640	640
	Height	mm	1,350	1,850	1,900	1,850
	Empty Weight	kg	61	100	146	106
	Tank Materials		STS:F18	STS:F18	STS:F18	STS:F18
Specification of Electric Back-up	Additional Electric Heater	W	2,400	2,400	2,400	2,400
	Power Supply	Φ / V / Hz	1 / 230 / 50(60)	1 / 230 / 50(60)	1 / 230 / 50(60)	1 / 230 / 50(60)
	Adjustable Thermostat	℃	0 - 90	0 - 90	0 - 90	0 - 90
	Exchanger Type		Single	Single	Single	Double
Specification of Heat Exchanger	Material Exchanger		STS:F18	STS:F18	STS:F18	STS:F18
	Maximum Water Temp	℃	90	90	90	90
	Coil Surface	m <sup>2</sup>	2.3	3.1	4.8	3.1+0.97
Water Connections	Heat Pump Inlet	inch	1 BSP Female	1 BSP Female	1 1/4 BSP Female	3/4 BSP Female (Upper Coil)
	Heat Pump Outlet	inch	1 BSP Female	1 BSP Female	1 1/4 BSP Female	3/4 BSP Female (Upper Coil)
	Solar Inlet	inch	-	-	-	1 BSP Female (Lower Coil)
	Solar Outlet	inch	-	-	-	1 BSP Female (Lower Coil)
	City Water Inlet	inch	3/4 BSP Male	3/4 BSP Male	1 BSP Male	3/4 BSP Male
	Hot Water Outlet	inch	3/4 BSP Female	1 BSP Female	1 BSP Female	1 BSP Female
Energy Efficiency Class		B	B	B	B	
Standing Heat Loss	W	61	70	83	70	

### MANDATORY ACCESSORIES

Domestic Hot Water Tank Installation Kit	PHLTA/PHLTB/PHLTC	PHLTA/PHLTB/PHLTC	PHLTA/PHLTB/PHLTC	PHLTA/PHLTB/PHLTC
--	-------------------	-------------------	-------------------	-------------------

### OPTIONAL ACCESSORIES

Mixing Valve (3/4" dn20)	OSHA-MV	OSHA-MV	OSHA-MV	OSHA-MV
Mixing Valve (1" dn25)	OSHA-MV1	OSHA-MV1	OSHA-MV1	OSHA-MV1
3-Way Valve	OSHA-3V	OSHA-3V	OSHA-3V	OSHA-3V

# LG Wi-Fi MODEM

Control LG THERMA V via using the internet devices as Android or iOS bases smartphones

PWFMDD200



## Features

- Access LG THERMA V anytime and from anywhere with Wi-Fi equipped device
- LG's exclusive Home Appliances control app(SmartThinQ) is available
- Simple operation for various functions
  - On/Off
  - Operation Mode
  - Current/Set Temperature



MODEL NAME	PWFMDD200
Size (W x H x D, mm)	48 x 68 x 14
Interfaceable Products	THERMA V Split Indoor unit
Connection Type	Indoor unit 1:1
Communication Frequency	2.4 GHz
Wireless Standards	IEEE 802.11b/g/n
Mobile Application	LG Smart ThinQ (Android v4.1(Jellybean) or higher, iPhone iOS 9.0 or higher)
Optional Extension Cable	PWYREW000 (10m extension)

- \* Functionality may be different according to each IDU model (Monobloc and Split only available)
- \* User interface of application shall be revised for its design and contents improvement
- \* Application is optimized for smartphone use, so it may not be well functioning with tablet devices
- 1) Vane Control may not be possible according to the type of Indoor unit
- 2) For the compatibility with Indoor unit, please contact regional office



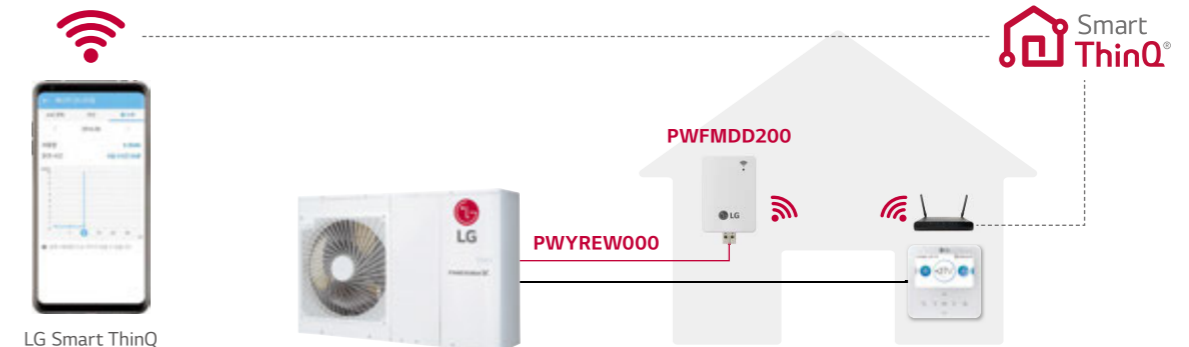





## Overview



















- \* Search "LG Smart ThinQ" on Google market or Appstore then download the app.
- \* Internet service with Wi-Fi connection has to be available

# ACCESSORIES

## Accessories Provided by LG

ACCESSORY	FEATURE
Domestic Hot Water Tank	 <p>OSHW-200F 200 LITRES</p> <p>OSHW-300F 300 LITRES</p> <p>OSHW-500F 500 LITRES</p> <p>Single Coil</p>  <p>OSHW-300FD 300 LITRES</p> <p>Double Coil</p>  <p>OSHA-3V 3-Way Valve</p>  <p>OSHA-MV OSHA-MV1 Mixing Valve</p>
Domestic Hot Water Tank Kit	<ul style="list-style-type: none"> <li>• PHLTA (1Ø, Split)</li> <li>• PHLTC (3Ø, Split)</li> <li>• PHLTB (Monobloc)</li> </ul> <p><b>Features</b> Easy to install the domestic hot water for monobloc. There is a MCCB to protect the product. Dimension (mm) (H x W x D) : 250 x 170 x 110 Weight (kg) : 2.1</p> <p>To extend THERMA V functionality in generating domestic hot water.</p> <p>* PHLTA, PHLTC is required only when you want to use the electric heater function at the sanitary tank. If not, it's not necessary. THERMA V indoor unit itself already has electric heater(back up heating) function.</p> <p>* The sensor (PHRSTAO) can be purchased separately in case of using other brand's Domestic tank.</p>  <p>PHLTA / PHLTC      PHLTB</p>
Remote Temperature Sensor	<ul style="list-style-type: none"> <li>• PQRSTAO</li> </ul> <p><b>Features</b> It can help to detect the exact room temperature. Applied to ceiling cassette, ceiling concealed duct, AWHP and Hydro Kit.</p> <p><b>Parts Included</b> Remote temperature sensor / Extension cable (15m) / Manual</p> 
Solar Thermal Kit	<ul style="list-style-type: none"> <li>• PHLLA</li> </ul> <p><b>Features</b> To interface solar-thermal system with THERMA V and double coil Domestic tank. Installed at the water pipe, between Domestic tank and solar-thermal system. Dimension (mm) (H x W x D) : 110 x 55 x 22</p> 
Dry Contact	<ul style="list-style-type: none"> <li>• PDRYCB000</li> </ul> <p><b>Features</b> For connection with boiler (Bivalent scene)</p> 
Drain Pan	<ul style="list-style-type: none"> <li>• PHDPB</li> </ul> <p><b>Features</b> Collects condensate water (When dropping to the base is not possible) and drains the water to a pipe</p> 

## Recommended Optional Accessories

NO.	ACCESSORY	PICTURE	PURPOSE	SPECIFICATION
1	Domestic Hot Water Tank		Store and provide hot water for sanitation	Volume : 200 - 400 l Enamel or stainless-steel tank / Insulating foam (e.g. PUR - polyurethane) heat-exchanger surface ≥ 3 m²
2	3-Way-Valve		Switch between heating and domestic hot water circuit	230V AC SPDT (Single Pole Double Throw) / opening time 30 - 90 sec / final position switch Internal leakage rate < 0,1%
3	Electrical Tank Heater		Supports heating of domestic hot water, when heat pump is blocked or capacity is limited	2 - 6 kW Connector dimension suitable for DHW tank
4	Buffer Tank		Prevents cycling, when water volume is low and / or heating demand is low; secures enough heat for defrosting cycle	Insulating foam (e.g. PUR - polyurethane) Volume : 100 - 200 l (Installation in series with heat pump) 500 - 1,000 l (Installation in parallel with heat pump)
5	Bypass Valve		Ensures minimum water flow rate, when flow through heating circuits is limited due to closed valves	Dimensioning according manufacturer adjustable opening pressure
6	2-Way-Valve		Blocks heating circuits, that are not suitable for cooling during cooling operation	230V AC NO or NC type final position switch
7	Expansion Vessel		Absorption of pressure differences in the heating circuits due to temperature increase / decrease of the water	Dimensioning on-site required
8	Strainer		Protects plate-heat-exchanger from blocking particles	1 inch / 25.4mm, Mesh size - 1 x 1mm for HM03M1.U42 only (other models are included)
9	Heating Cable		Prevents the condensate pan and the drainage pipe from icing	Thermostatic control depending on outdoor temperature All models do have electric heating cable for prevent frost from condensing water at the condensing pan except 3kW capacity.
10	Antifreeze		Prevents the heating water from freezing, when heat pump is out of order	Monoethyleneglycole Concentration according to lowest possible outdoor temperature
11	Noise Damper		Prevents that structure-born noise is transported via the water piping	EPDM; Operating temperature according climate region (at least -10 - + 90°C)
12	Anti-Noise Sockets		Prevents that structure-born noise is transported to the base or to the brackets	Dimensioning on-site required
13	Thermostat		When thermostatic room temperature control is preferred by customer	230V AC When heat pumps operates in heating and cooling mode : thermostat with mode selection
14	Refrigerant Tubes		Pre-fabricated double-pipe to connect split indoor and outdoor unit	Diameter : Please refer to Specification
15	Water Tubes		Pre-fabricated double-pipe to connect monobloc outdoor unit with heating system	When heat pump is used for cooling : diffusion-resistant tubes
16	Bushing Sleeve		Protecting the building against pressing water coming through the duct of the heating tubes	Dimensioning on-site required
17	Insulation Material		Mandatory when heat pump is used for cooling; prevents condensate water on cold pipes and assemblies	Diffusion-resistant

# LG LATS THERMA V

## THERMA V Selection Program

LATS THERMA V simulates quick and easy result of THERMA V's economic benefits. By specifying a number of parameters, this program shows annual energy cost compared with conventional heating system and CO<sub>2</sub> annual amount, monthly energy amount and cost, total amount of thermal energy in kWh as the outside temperature.

