



www.balavto.com



BALAVTO

Your best partner for construction equipment



USED CONSTRUCTION MACHINERY AND TRUCKS



DIFFERENT ATTACHMENTS FOR EXCAVATORS AND LOADERS



CUSTOM MADE ATTACHMENTS



HYDRAULIC BREAKERS BAT



NEW, RENEWED AND USED SPARE PARTS FOR MACHINERY

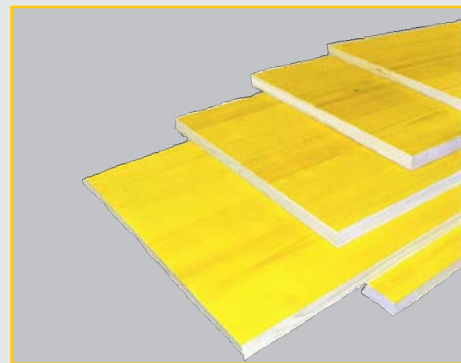

WOODEN PRODUCTS: PANELS, LAMINATE, SAWN WOOD



TRANSPORTATION

...

CONTACT PERSONS



Mr. Jože Bajec,
Company Owner
Balavto Ltd.
Slovenia, Europe
Phone: + 386 5 365 99 00
Mob: + 386 41 627 399
email: joze@balavto.si



Branko Kobal
GENERAL MANAGER
Balavto Ltd. Ajdovscina
Machines and attachments
e-mail: branko@balavto.si
Phone: + 386 5 365 99 00
Gsm: +386 41 726 113



Nadja Kobal
Administrative support from Headquarter
Phone 1: +386 31 627 397
Phone 2 +386 5 365 99 00
email: nadja@balavto.si



Marko Bajec
Stone Crushers, Tower Cranes,
Tunneling Equipment
e-mail: marko@balavto.si
Phone: + 386 5 365 99 00
Gsm: +386 31 627 399

Main activity of our Company, Balavto Ltd. Ajdovščina is trading Construction equipments for diverse needs of the industry and Transportation vehicles for minerals and grain aggregates transportation.

Our company has gained in all the 18 years of its work since its foundation, high recognition and the status of a leading company in the sales area for construction equipment in Slovenia and region, where it operates as the general representative for Volvo Construction Equipment.

Besides new machines, we have more than 200 used machines and attachments in stock: excavators, loaders, dampers, dozers, backhoe loaders, tower cranes stone crushers, rollers, tracks, hydraulic breakers, etc.). Our stock of used machinery changes quickly. Even if do not have required machine in our stock, we get any kind of machinery in accordance with customers needs.

Many years of experience in attachments sales, regular contacts with clients and respecting their opinions regarding issues and needs in the area of attachments led to the development of our own production of attachments for construction machinery. In our specialized work we produce different kinds of attachments for Construction (Heavy) Machinery (buckets, grabs, crushers, quick fits, forks ...).

Beside new spare parts, we also have a vast choice of used spare parts for all kinds of machinery from our used, dismantled machines on excellent prices (used/renewed engines, gearboxes, axles, hydraulic pumps, hydraulic cylinders, reducers, electrical systems, cabs, brake systems, computers, undercarriage... and many more)

We hope that in our Sale program You will find the equipment that suits Your needs and will contribute to new successes in Your business!



Martin Jerončič
New and used Machinery sale,
attachments sale
e-mail: martin@balavto.si
Phone: + 386 5 365 99 00
Gsm: +386 51 346 110

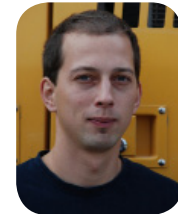

Ervin Rustja
Service Manager Assistant
e-mail: ervin@balavto.si
Phone: + 386 5 365 99 00
Gsm: +386 51 632 463



David Puc
Trucks, Rubber Tracks,
Aluminium platforms,
Wooden products
e-mail: david@balavto.si
Phone: + 386 5 365 99 00
Gsm: +386 41 265 752



Tadej Čoha
New, renewed and used
spare parts
e-mail: tadej.coha@balavto.si
Phone: + 386 5 365 99 00

Niko Bajec, Transportation
e-mail: niko@balavto.si
Phone: + 386 5 365 99 00 Gsm: +386 31 381 694



USED CONSTRUCTION EQUIPMENT

Used: Machinery, Attachments, Tower Cranes, Trucks and Trailers, Spare Parts ...

With more than 200 pieces of used Machines, Trucks and Equipment in Stock, Balavto Ltd. represents the leading company and the biggest trader of used Equipment in the region.



Our stock of used machinery changes quickly. Even if do not have required machine in our stock, we can get any kind of machinery or equipment in accordance with customers needs.



Please check the current offer of our used equipment online (on our web pages stated below), or contact us if you need any special Machine.

www.balavto.com

Used Construction Machinery, Trucks and Equipment

www.usedspareparts.net

Used Spare parts of Construction Machinery

www.usedtowercrane.net

Used Tower Cranes

www.hydraulic-breaker.net

Used and new Hydraulic breakers



Crawler Excavators



Wheeled Excavators



Compact Excavators



Wheel Loaders



Compact Loaders



Backhoe Loaders



Attachments



Dozers



Dumpers



Rollers



Graders



Pavers



Stone Crushers



Sowing Equipment



Milling/Drilling Equip.



Tunneling Machines



Asphalt Plants



Tower Cranes



Trucks and Trailers



Concrete Mixers/Pumps



Hydraulic Breakers



Used Spare Parts



Rims and Tyres



Other: compressors, agregates, pumps ...

DUMPERS 6x6

FOR TRANSPORTATION WOOD FROM SWAMP, FOR SUGAR CANE TRANSPORTATION, etc.

Dumpers with 6x6 drive appropriate for all kinds of terrains. They are very suitable for transportation wood from swamp areas.

Dumpers can be equipped with wide tyres and with superstructure for wood transportation, with or without crane.

Crane can be mounted at the end of chassis or right behind the cab.

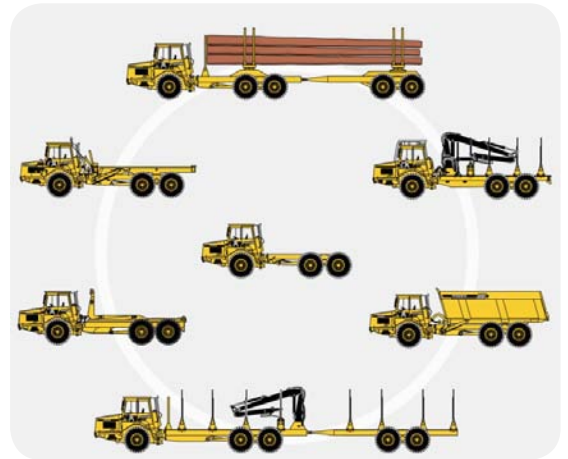

Dumper used for wood transportation



Dumper used for sugar cane transportation



Dumper with mounted crane



EXCAVATORS FOR SUGAR CANE AND BAMBOO LOADING WITH OTHER ATTACHMENTS FOR USE



Excavators for Sugar cane and Bamboo loading

Excavators with the special grab for Sugar cane and Bamboo loading are excellent alternative for other machinery intended for Sugar cane or Bamboo loading (Sugarcane Loaders). The biggest advantage of using excavator for Sugar cane loading is economy - after changing the attachment you can use the same excavator for many other different works.

Below you can find wide range of attachments for the excavators and description of their usage. We can provide all attachments for excavators, some of them we can also produce in accordance with your needs (custom-made). If you need any kind of attachment, contact us and we will find the best solution for you.













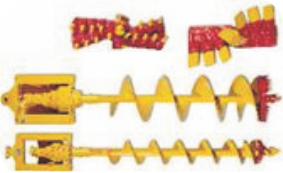

ATTACHMENTS FOR EXCAVATOR













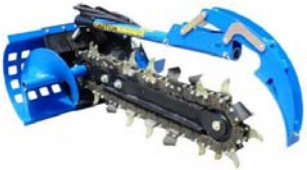



<p>1.</p> 	<p>GRAB FOR SUGAR CANE AND BAMBOO</p> <p>Grab used for Sugar cane and Bamboo loading.</p> <p>GRAB made on Balavto Ltd. We produce all kinds of grabs in our company (custom-made). More about our attachment production on page 18.</p>	
<p>2.</p> 	<p>GRABS FOR STONES</p> <p>These are some kind of universal grapples and are used for: wood, soil, stones, moving attachments on the site etc. Most usually they are used for moving and placing the stones.</p> <p>GRAB made on Balavto Ltd. We produce all kinds of grabs in our company (custom-made). More on page 18.</p>	
<p>3.</p> 	<p>POLYP GRABS</p> <p>Polyp grab is mostly used for different materials grabbing - materials which shape and size can vary. Often used for waste materials grabbing.</p> <p>GRAB made on Balavto Ltd. We produce all kinds of grabs in our company (custom-made). More on page 18.</p>	

<p>4.</p> 	<p>GRABS FOR SOIL AND SAND</p> <p>Closed grab used for grabbing loose material: sand, soil etc.</p> <p>GRAB made on Balavto Ltd.</p> <p>We produce all kinds of grabs in our company (custom-made). More on page 18.</p>	
<p>5.</p> 	<p>HANGING LOG GRABS</p> <p>Hanging grab is specially made for log manoeuvring.</p> <p>GRAB made on Balavto Ltd.</p> <p>We produce all kinds of grabs in our company (custom-made). More on page 18.</p>	
<p>6.</p> 	<p>GRABS FOR CROSS-TIE PLACING</p> <p>This grab is specially made for cross-tie placing.</p> <p>GRAB made on Balavto Ltd.</p> <p>We produce all kinds of grabs in our company (custom-made). More on page 18.</p>	
<p>7.</p> 	<p>GRABS FOR HOSES</p> <p>Grab made for hoses manoeuvring.</p> <p>GRAB made on Balavto Ltd.</p> <p>We produce all kinds of grabs in our company (custom-made). More on page 18.</p>	
<p>8.</p> 	<p>INTEGRATED GRAB FOR TILTROTATOR</p>	
<p>9.</p> 	<p>GRAB INTEGRATED ON CONNECTING PLATE</p> <p>Made on Balavto Ltd.</p> <p>More about our attachments production on page 18.</p>	
<p>10.</p> 	<p>BUCKETS WITH GRAPPLE</p> <p>Often used during electrical column placing, in forestry etc.</p> <p>Bucket made on Balavto Ltd.</p> <p>On Balavto Ltd. we produce all kinds and sizes of swiveling buckets for excavators. More about our attachments production on page 18.</p>	

<p>11.</p> 	<p>DIGGING BUCKETS - CLASSIC</p> <p>Standard digging buckets. On Balavto Ltd. we produce all kinds and sizes of digging buckets for excavators. More about our attachments production on page 18.</p>	
<p>12.</p> 	<p>DIGGING BUCKETS - HEAVY DUTY</p> <p>Bucket for more difficult conditions. On Balavto Ltd. we produce all kinds and sizes of digging buckets (heavy duty) for excavators. More about our attachments production on page 18.</p>	
<p>13.</p> 	<p>DIGGING BUCKETS - FOR STONE</p> <p>On Balavto Ltd. we produce all kinds and sizes of buckets for stone. Bucket made on Balavto Ltd. More about our attachments production on page 18.</p>	
<p>14.</p> 	<p>NARROW (CANAL) BUCKETS</p> <p>On Balavto Ltd. we produce all kinds and sizes of canal buckets for excavators. Bucket made on Balavto Ltd. More about our attachments production on page 18.</p>	
<p>15.</p> 	<p>DICH CLEANING BUCKETS</p> <p>On Balavto Ltd. we produce all kinds and sizes of ditch cleaning buckets for excavators. Bucket made on Balavto Ltd. More about our attachments production on page 18.</p>	
<p>16.</p> 	<p>SWIVELING BUCKETS</p> <p>On Balavto Ltd. we produce all kinds and sizes of swiveling buckets for excavators. More about our attachments production on page 18.</p>	
<p>17.</p> 	<p>SWIVELING BUCKETS</p> <p>On Balavto Ltd. we produce all kinds and sizes of swiveling buckets for excavators. Bucket made on Balavto Ltd. More about our attachments production on page 18.</p>	
<p>18.</p> 	<p>TRAPEZIOD BUCKETS</p> <p>On Balavto Ltd. we produce all kinds and sizes of swiveling buckets for excavators. More about our attachment production on page 18.</p>	

<p>19.</p> 	<p>MIXER BUCKETS</p> <p>Buckets for concrete mixing.</p>	
<p>20.</p> 	<p>BUCKETS WITH TONGUE</p> <p>Special buckets with tong, attached to the excavators arm, are often used for stone placing, log handling etc. Bucket made on Balavto Ltd. More about our attachment production on page 18.</p>	
<p>21.</p> 	<p>ROTARY SCREENING BUCKETS</p> <p>Used for screening different natural materials: soil, sand and other. In all situations where screening is needed.</p>	
<p>22.</p> 	<p>CRUSHING BUCKETS</p> <p>Used for recycling and reuse of waste material deriving from construction and demolition work.</p>	
<p>23.</p> 	<p>FORKS FOR EXCAVATORS</p> <p>Different dimensions of forks for all kinds of excavators</p>	
<p>24.</p> 	<p>MULCHERS</p>	
<p>25.</p> 	<p>PROCESSING HEADS</p> <p>Mostly used in forestry for log processing.</p>	

<p>26.</p> 	<p>MILLING EQUIPMENT</p> <p>For asphalt/concrete</p>	
<p>27.</p> 	<p>MILLING EQUIPMENT</p> <p>For soil</p>	
<p>28.</p> 	<p>DRILLING EQUIPMENT FOR SOIL</p>	
<p>29.</p> 	<p>DRILLING EQUIPMENT FOR ROCKS AND STONES</p>	
<p>30.</p> 	<p>COMPACTORS</p> <p>For soil compacting</p>	
<p>31.</p> 	<p>STONE CRUSHERS</p> <p>Most usually used for concrete or stone crushing etc. Crusher made on Balavto Ltd. More about our attachments production on page 18.</p>	
<p>32.</p> 	<p>STEEL SHEARS</p> <p>Most usually used for iron, etc.</p>	

<p>33.</p> 	<p>CONCRETE SHEARS</p> <p>Most usually used for concrete crushing, concrete with iron frames, iron, etc.</p>	
<p>34.</p> 	<p>TRENCHER</p> <p>Trenchers for ditches</p>	
<p>35.</p> 	<p>PILE DRIVERS</p>	
<p>36.</p> 	<p>ARM EXTENSIONS</p> <p>Effective tool to overcome some physical obstacles and reach positions that are well above and below the excavator.</p> <p>Arm extension made on Balavto Ltd. More about our attachments production on page 18.</p>	
<p>37.</p> 	<p>ARM EXTENSIONS</p> <p>Effective tool to overcome some physical obstacles and reach positions that are well above and below the excavator. In Balavto we produce all kinds of arm extensions. More about attachments production on page 18.</p>	
<p>38.</p> 	<p>TELESCOPIC EXCAVATOR ARM</p>	
<p>39.</p> 	<p>EXCAVATOR BLADES</p> <p>Different blades for excavators. We can also produce blade in accordance with your requires - custo-made. More about our attachments production on page 18.</p>	
<p>40.</p> 	<p>CABLE PLOUGHING ATTACHMENTS</p> <p>Easy and quick cable placing in ditches.</p>	

<p>41.</p> 	<p>HYDRAULIC BREAKERS</p> <p>Different sizes of hydraulic breakers for all kinds of excavators.</p>	
<p>42.</p> 	<p>RIPPERS</p> <p>Mostly used: for cleaning soil from stones and rocks, for soil softening ... We produce all kinds of rippers (custom-made). More about our attachment production on page 18.</p>	
<p>43.</p> 	<p>ASPHALT CUTTERS</p> <p>We produce all kinds of asphalt cutters (custom-made). More about our attachments production on page 18.</p>	
<p>44.</p> 	<p>POWER TILT</p> <p>Enables positioning the bucket (or other attachment) in any position you want, regardless of excavator position.</p>	
<p>45.</p> 	<p>TILTROTATORS</p> <p>Enables unlimited rotation of the attachment and tilting of up to 40° in two directions.</p>	
<p>46.</p> 	<p>QUICK FITS</p> <p>For all kinds and sizes of excavators.</p> <p>We produce all kinds of quick fits - check our production on page 18.</p>	
<p>47.</p> 	<p>B-QUICK QUICK COUPLERS</p> <p>For attaching hydraulic hoses of attachments (hydr. breakers etc) to the excavator.</p> <p>B-QUICK made on Balavto Ltd.</p> <p>More about our attachments production on page 18.</p>	
<p>48.</p> 	<p>SWEEPERS</p> <p>Sweepers for excavators.</p>	



LOADER ATTACHMENTS















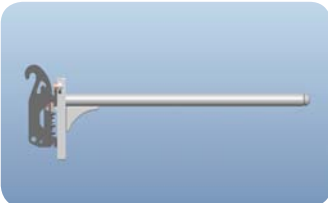

Loaders for Sugar-cane and Bamboo loading

Loaders with the special grab for Sugar-cane loading are excellent alternative for other machinery intended for Sugar-cane loading (Sugar-cane Loaders). The biggest advantage of using Loaders for Sugar cane loading is economy - after changing the attachment you can use the same Loader for many other works.

Below you can find wide range of attachments for the Loaders and description of their usage. We can provide all attachments for Loaders, some of them we can also produce in accordance with your needs (custom-made). If you need any kind of attachment, contact us and we will find the best solution for you.

ATTACHMENTS FOR LOADERS		
<p>1.</p> 	<p>GRABS FOR SUGAR-CANE AND BAMBOO</p> <p>Differernt grabs regard to the needs and works to perform.</p> <p>GRAB made on Balavto Ltd. More about our attachment production on page 18.</p>	
<p>2.</p> 	<p>GRABS</p> <p>Differernt grabs regard to the needs and works to perform.</p> <p>General purpose grabs, Unloading grabs Tree-lenght grabs, Grabs with rotator</p> <p>Some grabs for loaders can be made in our company (custom-made). More about Our production on page 18.</p>	

<p>3.</p> 	<p>BUCKETS</p> <p>All kinds of buckets for loaders.</p> <p>Some of the buckets can also be produced in our company (custom-made). More about Our Production on page 18.</p>	
<p>4.</p> 	<p>MIXER BUCKETS</p> <p>Concrete mixing buckets for loaders.</p>	
<p>5.</p> 	<p>LIGHT MATERIAL BUCKETS</p> <p>Light Material Bucket has high capacity for handling low density materials (0,6 ton/m³ or less), such as snow, wood, chips etc. In our company we produce light material buckets. More about our attachments production on page 18.</p>	
<p>6.</p> 	<p>BUCKETS WITH CLAMPS</p> <p>Bucket with wide bottom and clamp is appropriate for handling waste material because, due to the clamp, material does not fall and it is possible to handle up to 25% more material than with the bucket without a clamp.</p>	
<p>7.</p> 	<p>HIGH-TIP LIGHT MATERIAL BUCKETS</p> <p>High-Tip Light Material Bucket with side mounted cylinders has high capacity for handling low density materials (0,6 ton/m³ or less), such as snow, wood, chips etc. The high tip bucket features considerably increased dump height over standard light material buckets because it is hydraulically lifted from a built-in frame. Dump height 4 - 7 m depending on loader and bucket type. In our company we can produce high-tip buckets. More about our attachments production on page 18.</p>	
<p>8.</p> 	<p>SIDETIP BUCKETS</p> <p>Bucket for side tipping.</p>	
<p>9.</p> 	<p>BUCKETS WITH FORKS</p> <p>Bucket with additional forks</p>	

<p>10.</p> 	<p>OPENING BUCKETS</p>	
<p>11.</p> 	<p>FORKS FOR LOADERS Different forks, depending on loader type available. The frame with the possibility of moving the forks represents an ideal solution in case that load width varies (hydraulic adjustment). Forks with an extended rear part of the framework, which allows a special safe handling of load. In our company we produce forks for loaders. More about our attachments production on page 18.</p>	
<p>12.</p> 	<p>COMBI-FORKS WITH ONE-PIECE CLAMP Combi-fork is perfect for handling palletized goods or roundwood in applications where the load must be secured. In our company we produce different forks for loaders. More about our attachments production on page 18.</p>	
<p>13.</p> 	<p>BIG-BAG FORKS Specialy designed forks for bags transportation. Enable easy and fast bags manouvring. Big-Bag forks made on Balavto Ltd. In our company we produce different forks for loaders. More about our attachments production on page 18.</p>	
<p>14.</p> 	<p>HAY BALE CLAMP Provide a firm load compression. Attachment has a function of pressure reducing and side shifting.</p>	
<p>15.</p> 	<p>MATERIAL HANDLING ARM The material handling arm is used on construction sites for pipelaying etc. It has two telescopic sections with built-in mechanical stops to prevent overextension. Thix arm is usually used on sites where load is loaded under or above the loader level or if there is insurmountable barrier, which otherwise should be bypassed.</p>	
<p>16.</p> 	<p>LOADER ARM EXTENSION We can attach fiffereent attachements on this extension: buckets, forks... This extension allows us to reach greater heights when loading or unloading, or loading over the physical obstacles.</p>	

<p>17.</p> 	<p>BLADES FOR LOADERS</p> <p>Different blades for loaders. We can also produce blade in accordance with your requires - custo-made.</p>	
<p>18.</p> 	<p>TILTING QUICK FIT</p> <p>Tilting quit fit for loaders enables tilting the attachment to side.</p>	
<p>19.</p> 	<p>SWEEPER WITHOUT CONTAINER</p> <p>Sweeper is suitable for sweeping surfaces, where it is not necessary to collect pieces of scrap materials. Connection can be additionally equipped with reservoir for water and water spray, which reduces the formation of dust when sweeping.</p>	
<p>20.</p> 	<p>SWEEPER WITH CONTAINER</p> <p>Sweeper with a container allows sweeping and waste collection at the same time. This attachment can be equipped with additional sweeper, mounted on the right, left or both sides.</p>	
<p>21.</p> 	<p>HIGH - LIFT</p> <p>For the log handling applications in the forestry, timber industry, etc.</p>	

BAT HYDRAULIC BREAKERS



Advantage of BAT hydraulic breakers

**Auto - stop
(Anti-Blank
Fire system)**

This function ensures less problems with the components and longer life of the hydraulic breaker.

**Upper Level
of Through
Bolt**

The size of through bolt is bigger than the one of other manufacturers to reduce breakage and to avoid loos of tightness.

**Accumulator
Built in**

Accumulator makes less stress on hydraulic components and absorbs pressure fluctuation inside the breaker.

**All Silenced
Model Range**

Sound suppression brackets and devices are applied to from small models to large models.

1. Noise Protector
2. Stroke adjuster
3. Accumulator (from BAT 30B)
4. Auto-Lubrication System
5. Rock dragger with anti-abrasion steel
6. Well heat-treated tool
7. Cusion Damper
8. Roomier Gas Chamber
9. Main valve
10. Piston
11. Wide Chisel pin

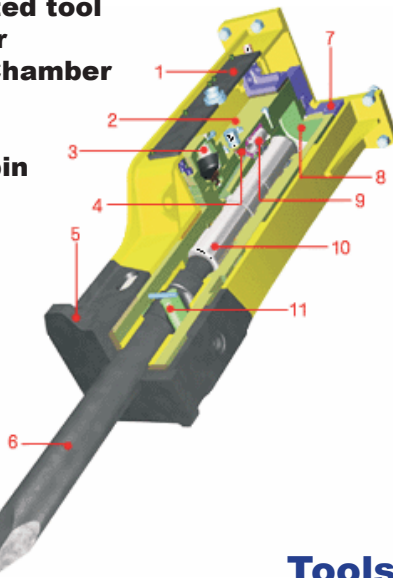

**For all sales of hydraulic hammers,
We offer full support:**

- Our technical team mounts the breaker to the basic machine and is responsible for its smooth functioning.
- Different Connection plates production (for attaching breaker to the machine).
- We offer you a special high-B-Quick couplings for hydraulic hoses (more on that later in the catalog).
- We have all kinds of tools and spare parts for hydraulic breakers in stock.

Tools and Spare parts for Hydraulic Breakers

All kinds of tools and spare parts for hydraulic breakers from different manufacturers:

D&A, Rammer, Krupp, Montabert, Atlas Copoco, Furakawa itd...

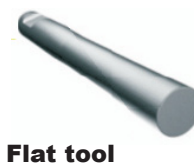

Technical specifications for hydraulic breakers

MINI HYDRAULIC BREAKERS

MODEL		BAT 8B	BAT 15B	BAT 20B	BAT 30 B	BAT 50B
Weight	kg	120	140	175	260	310
Impact power	J	177	343	392	696	902
Required Oil flow	l/min	15-30	23-45	26-50	30-60	35-70
Operating pressure	kg/cm ²	90-120	90-120	100-140	110-165	110-165
Blow rate	bpm	550-1000	450-800	450-800	550-1100	380-1000
Overall Length	mm	1130	1259	1317	1513	1597
Tool	mm	45	57	57	70	70
Relief Valve Setting Pressure	kg/cm ²	175	175	175	175	175
Suitable Carrier	t	0,8 - 2,5	1,0 - 3,0	1,5 - 4,0	2,0 - 4,5	3,0 - 6,5

SMALL HYDRAULIC BREAKERS

MODEL		BAT 60B	BAT 70B	BAT 80B	BAT 100B	BAT 130B	BAT 150B
Weight	kg	330	495	545	800	900	1150
Impact power	J	981	1187	1461	2158	2518	3665
Oil flow	l/min	40-80	45-90	50-100	75-120	80-140	100-150
Operating pressure	kg/cm ²	120-165	140-170	140-170	140-180	140-180	150-210
Blow rate	bpm	380-900	400-1100	350-1000	350-900	350-900	320-900
Overall Length	mm	1639	1849	2062	2125	2234	2442
Tool	mm	75	80	90	95	105	115
Relief Valve Setting Pressure	kg/cm ²	175	175	175	175	210	210
Suitable Carrier	t	4,5-8	4,5-8	6-10	8-12,5	10-15	12-18

MEDIUM HYDRAULIC BREAKERS

MODEL		BAT 180B	BAT 200B	BAT 220B	BAT 250B
Weight	kg	1450	1580	1800	2000
Impact power	J	3880	4527	5350	7203
Oil flow	l/min	100-155	120-170	140-190	160-190
Operating pressure	kg/cm ²	160-190	160-190	160-190	160-190
Blow rate	bpm	320-800	320-800	320-800	300-720
Overall Length	mm	2522	2589	2775	2906
Tool	mm	125	135	135	145
Relief Valve Setting pressure	kg/cm ²	210	210	210	210
Suitable Carrier	t	16-22	18-24	20-26	25-30

LARGE HYDRAULIC BREAKERS

MODEL		BAT 300B	BAT 360B	BAT 450B	BAT 550B
Weight	kg	2400	2700	3300	3800
Impact power	J	8751	10897	12250	15240
Oil Flow	l/min	180-240	200-260	220-280	240-320
Operating pressure	kg/cm ²	160-190	160-190	160-190	160-190
Blow rate	bpm	250-650	230-600	230-600	230-550
Overall Length	mm	3016	3085	3508	3580
Tool	mm	150	155	165	175
Relief Valve Setting pressure	kg/cm ²	210	210	210	210
Suitable Carrier	t	25-36	28-42	34-50	40-60



www.balavto.com

Many years of experience in attachments sales, regular contacts with clients and respecting their opinions regarding issues and needs in the area of attachments led to the development of our own production of attachments for construction machinery. In our specialized workshop we manufacture a variety of special attachments.

We can make also other attachments that are not in the catalogue - on request !!!



EXCAVATOR ATTACHMENTS PRODUCTION

EXCAVATOR BUCKETS

Different bucket production: digging buckets, swiveling buckets, canal buckets and other, custom made special buckets. Capacity, dimensions and connection on the bucket depend on the excavator on which the bucket is going to be used and are all custom made.

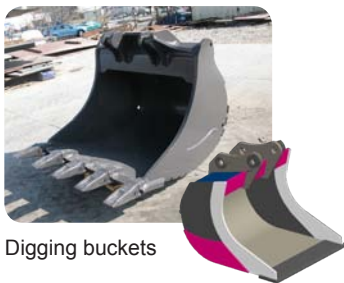

Digging buckets



Canal buckets



Ditch cleaning buckets

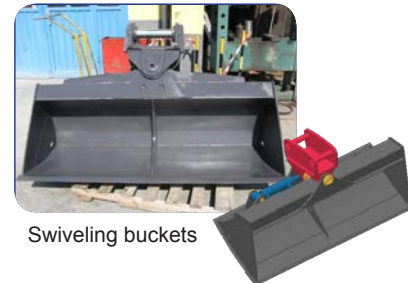

Swiveling buckets

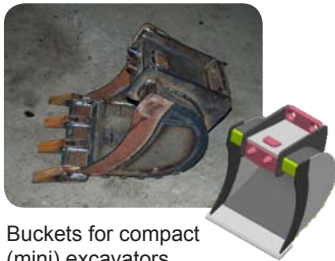

Buckets for compact (mini) excavators



Buckets with Grab mounted



Buckets with Tongh



Buckets for stone placing



Buckets for Backhoe Loaders

DEMOLITION SHEARS

Demolition Shears for crushing slag, concrete, stone etc. Shears and elements for the connection on the shears, depend on the type of machine and work and are made according to the needs of the customer or the type of work.

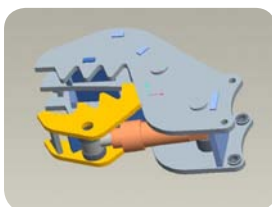

GRABS FOR EXCAVATORS

Hydraulic grab BG16 is intended to be used on excavators from 16 - 23 tons. It is often used for: classical grabbing - material handling (for stone, wood, iron..), for material sorting on garbage dumps and during demolition works, for stone placing (making scarps), etc.

Grab Model BG16

There are three possible versions of Hydraulic Grab BG16:

1. Grab BG16 without Rotator (intended to be used with Tiltrotator)
2. Grab BG16 with Rotator (360° rotation)
3. Grab BG16 with hanging Rotator



Grab Model BG16 without Rotator (intended to be used with Tiltrotator)

Applicability of hydraulic grab without rotator can be optimized by adding tiltrotator which is like a „wrist“ linked between excavator and grab. Tiltrotator provides unlimited rotation and tilting up to 40 degrees in two directions.



Hydraulic grab BG16 is also appropriate for works of stone laying - making the scarps.

Grab Model BG16 with Rotator

Rotor transmits major amount of axial and radial force and insures a great grab rotary performance. It enables 360° and increases grabs applicability.



Grab Model BG16 with mounted rotator



It reaches great results on a garbage dumps for works of sorting and recycling of waste material



Appropriate for demolition works

Grab Model BG16 with hanging Rotator

Hanging Grab is intended for use in situations where precise handling is not so important and represents great tool in working with waste material on garbage dumps, with waste iron, wood, etc.



Grab Model BG13

Hydraulic grab BG13 is intended to be used on excavators from 12 to 16 tons. It can also be delivered in three different versions: with mounted Tiltrotator, with integrated Rotator or with hanging Rotator.



Grab BG13 without rotator



BG 13 without rotator connected to the excavator with Tiltrotator



Grab BG13 with mounted rotator



Grab Model BG8

Small hydraulic grab BG8 made for smaller excavators from 5 to 8 tons excavators. It can also be delivered in three different versions: with mounted Tiltrotator, with integrated Rotator or with hanging Rotator.



BG8 with Tiltrotator



BG8 with Rotator

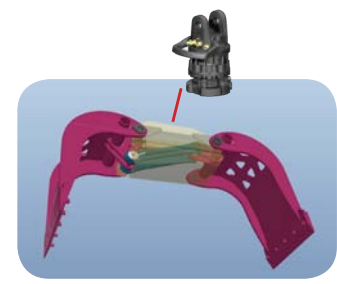

BG8 with hanging Rotator



Other, special grabs for Excavators



Polyp grab



Grapples for the cross-tie placing



Grab with rough jaw



Hanging Grab with rotator



Grab for sand and soil



Grab for hoses

If you need any kind of grab for your excavator, please contact us: phone. +386 5 365 99 00

LONG REACH ARM - EXCAVATOR ARM EXTENSION -

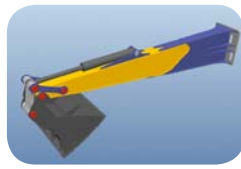

Effective tool to overcome some physical obstacles and reach positions that are much above or below the excavator level. The dimensions of the Long Reach arm are different depending on the excavator on which they are going to be used.

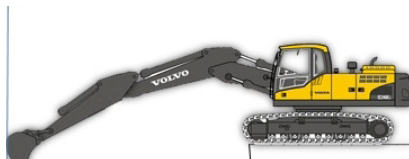

A - Digging reach = 9,8 m
Volvo EC240 with Standard 2,5m arm



B - Digging reach = 15 m
Volvo EC240 with arm extension - Long reach Arm



Volvo EC240 with arm extension - Long reach Arm, an excellent tool on site



Underwater digging - Arm extension enables digging in positions that are much below excavator level - for example digging in the water (sea, river ...)



Underwater concreting - Arm extension enables concreting in a higher water depths (longer distance). It guides the funnel to required depth and enables underwater concreting.

QUICK FITS

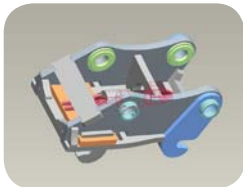

Quick fits models B1 and B2 enable to use the same tools for the operation with the excavator (such as for example excavator buckets, couplings for hydraulic hammers, different grabs, etc.) on a wider range of machines, which means that the machines with 14 to 24 tons of nominative value can have the same tools, what was impossible till now due to different types of quick fits.



Bucket and Quick fit, both made on Balavto



Quick fit B1



Quick fit B1 attached to the bucket

Quick fits models B1 and B2 manufactured and patented in our Company for changing tools on excavators solve the problem of tools' breaking and increase the operating power of the bucket teeth.

Advantages of Quick fits made on Balavto Ltd.:

- Increase the operating power of the bucket teeth namely increase the operating machine thrift
- Prolongation of the operating life of the quick fit, of other flexible parts of the machine and of the machine itself
- Increase the coupling strength between male and female parts of the quick fit
- The possibility to rotate the tool for 180° (just with the quick fit B1)
- Simplicity of manufacturing adapter plates for hydraulic hammers, shears...)
- Operation reliability

Bucket connected to the machine with Quick fit B1



Classic way of bucket connecting



B1 Quick Fit and bucket turned for 180° and connected to the excavator (which enables B1 quick fit)

Quick fits for hydraulic hoses B-QUICK



The special B-quick fits, manufactured in our Company, enable easy and fast coupling of the hydraulic breakers to the base machine. They reduce also the oil flow resistance and enable a constant oil flow without unnecessary hindrances.

Because of their reliability (without oil leakage), they ensure high security and your personnel safety. Our products are environmental friendly.

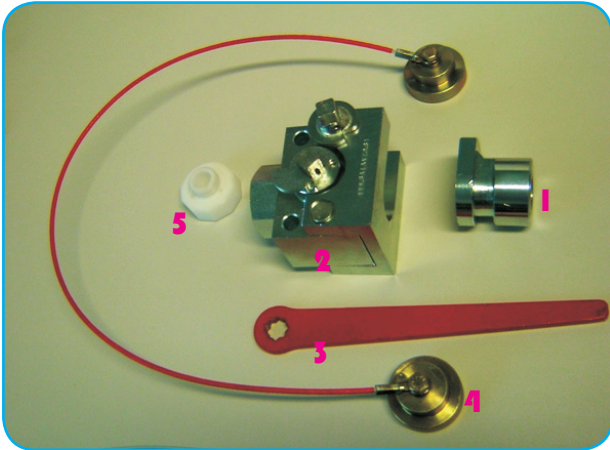

- The set consists of:
- 1,2 - 2x complete valves
(2x male part, 2x female part)
 - 3 - 2x key
 - 4 - 2x plug for the valve connected with wire rope
 - 5 - 2x cap for hydraulic device tubes (hydraulic breakers, leveling buckets...)
 - 1x Instruction manual

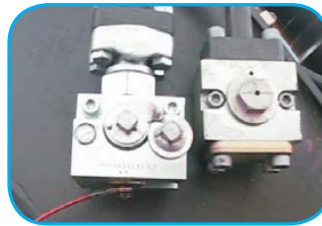

B-Quick on excavator arm



Hydraulic hose attached to the B-Quick

Advantages of B-Quick

- Fast and easy mounting the hydraulic attachments (breakers, tiltrotators, shears ...).
- 100 % oil flow through B-quick.
- Shock resistance increases the lifetime
- There is no oil leakage during the connection and dismanteling, and therefore B-Quick is environmental friendly product.



Attachments production



Hydraulic breaker hoses attached to the excavator with B-Quick



Fast and easy connection! You can connect the attachment to the machine in max. 3 minutes.



Hydraulic shears hoses attached to the excavator with B-Quick



100% oil-flow through B-Quick

CONNECTING PLATES



Different Connecting Plates production. Connection plates for hydraulic breakers and other attachments, are made regarding the kind of attachment and machine on which is going to be used.



OTHER ATTACHMENTS AND SOLUTIONS FOR EXCAVATORS

- Rippers
- Forks for Excavators
- Lifting arm
- Asphalt Cutters
- Special protecting glass on the excavator cab
- Other individual solutions



Rippers for excavators



Asphalt cutters for excavators



Volvo EC210C excavator with special protecting glass on the cab - made by Balavto Ltd.



Hydraulic Breaker Carrier positioned on the Blade is an excellent help during the Breaker transportation from one site to another.

PINS AND BUSHING

Pins and bushing production

We can make all kinds and dimensions of pins and bushings - custom made.

Pins and bushing replacement

Changing (mounting) the old and wore pins and bushing with a new ones

Repairing the old and damaged pins and bushing

We repair damaged pins and bushing (in our workshop or on the terrain) and make the original holes



Pins and bushing production - custom made

LOADER ATTACHMENTS PRODUCTION

LOADER BUCKETS

Loader buckets production - custom made buckets

Different capacity and dimensions of the buckets, regarding the loader on which it is going to be used and the kind of work which is to be done! Connection element on the bucket is also made in compliance with the loader, or regarding to the customers requests.

Beside new buckets production, we also repair damaged and worn out buckets.



High - tip buckets



Light material buckets



Opening buckets



Buckets with clamps

GRABS FOR LOADERS

We make different kinds of Grabs for Loaders:

- General purpose grapples
- Loading and unloading grapples (for logs)
- Sorting grabs
- Tree-length grapples
- Grapples with rotator
- Grabs for bamboo
- Grabs for sugarcane



Log grabs for loaders



Grabs for Bamboo



Grabs for Sugarcane

FORKS FOR LOADERS

Different forks for loaders:

- Standard (mechanical) forks
- Hydraulic forks (hydraulic moving of forks to the left or right/together - separately).
- Big -Bag forks



Standard forks



Big - Bag forks for bags

BALAVTO PRODUCTION

- SPECIAL PRODUCTS AND SERVICES -

DUMPER BODIES FOR LIGHT MATERIALS

In Balavto company we desing and produce dumper bod-ies for light materials. Dimensions and volume of bodies are different and in compliance with a dumper size (type). Those bodies are appropriate for light materials such as: coul, ashes, wood chips, etc.

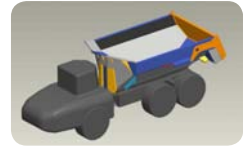

Light material dumper bodies are often used in Termal Power Plants for ash transportation

Dumper body can be firmly closed (sealed) so it is also appropriate for liquide materials transportation

CHASSIS AND BODIES FOR TRUCKS

Production of Chassies and Bodies for Transportation vehicles. We can make bodies and chassies for all kinds of trucks - please contact us for more information.

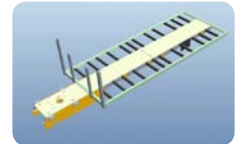

INDIVIDUAL SOLUTIONS



Hydraulic Breaker Carrier



Protective Cab Glass



Special connecting plate with the grab



Milling Equipment

SERVICES

In our workshop hall we offer different kinds of services: welding processes, attachments and equipment repairing (buckets, grabs, pins, bushing, etc.), plasma cutting, mounting the attachments and components to the machine, etc.



Tiltrotator

A tiltrotator can be described as a wrist between the excavator and the tool (attachement). An integrated control system gives you unlimited rotation and tilting of up to 40° in two directions. Our tiltrotators have a hydraulic quick hitch as standard, allowing the operator to change buckets and other tools quickly and easily without getting out of the cab.

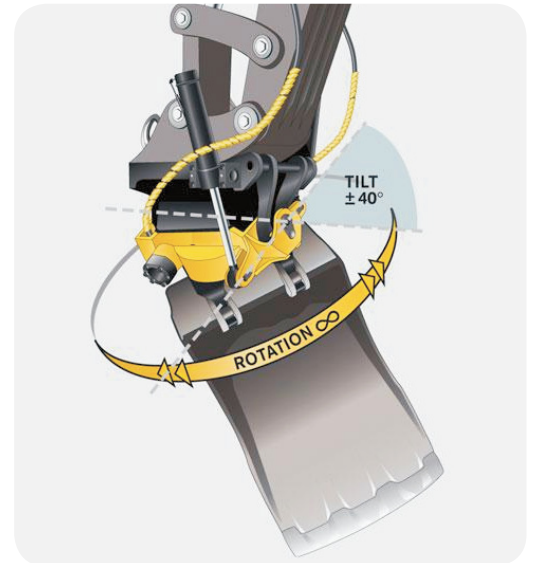

Unlimited rotation and tilting of up to 40° in two directions



Advantages:

- Unlimited rotation and tilting of up to 40° in two directions
- Increases the functionality of machine.
- Less room needed to maneuver the machine.
- Increases the range of reach for the attachment.
- Increases the working precision.
- It replaces the function of a swiveling bucket with additional rotation and possibility of attaching the different tools (attachements) on it: grapples, shears, asphalt cutters etc.)

Suitable for various types of works:

- During the finishing works on the ground
- In combination with grapple suitable for laying stones and making the stone.
- Very convenient when you work on the railway lines, where we have a machine set on rails.
- In combination with shears is very useful when you work in the forest (forestry)
- In combination with the asphalt cutter is very useful for works on roads.

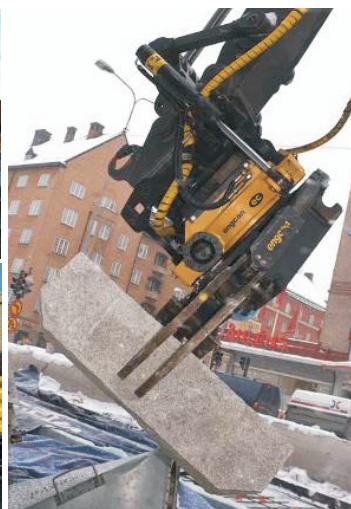

SPARE PARTS

We offer original spare parts for construction equipment: VOLVO; AKERMAN, SAMSUNG, ZETTELMEYER, RAMMER, D&A, CUMMINS as well as competitive parts for other construction equipment from different producers.



HYDRAULIC PUMPS AND COMPONENTS

We can provide different hydraulic pumps and spare parts for pumps for all kinds of construction machines.

Hydraulic pumps

For ordering the right hydraulic pump, we need you to provide us next data:

Machine data

Machine type (Excavator, wheel loader,...):
 Machine make (Volvo, Cat,):
 Machine model:
 Machine serial number:

Pump data

Pump type:
 Pump mark:
 Pump serial number:
 Type of the regulator on pump:
 Dimensions and description on Picture 1

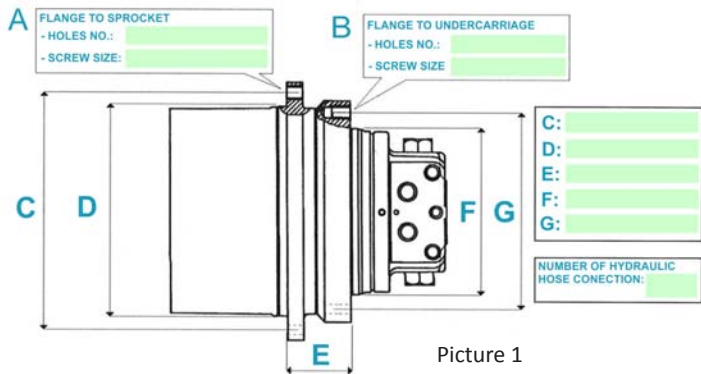

Picture 1

Hydraulic pump components (spare parts)

For ordering the right hydraulic pump component (part), we need you to provide us next data:

Machine data

Machine type (Excavator, wheel loader,...):
 Machine make (Volvo, Cat,):
 Machine model:
 Machine serial number:

Pump data

Pump type:
 Pump mark:
 Pump serial number:
 Type of the regulator on pump:
 Part number form on Picture 2

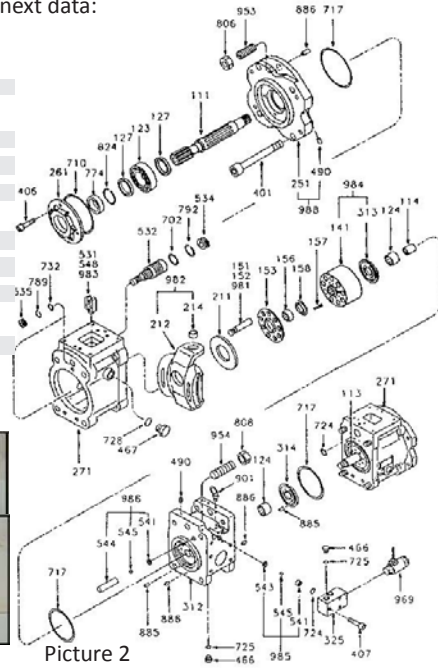

Picture 2



ENGINES AND SPARE PARTS FOR ENGINES

We can provide any kind of engine and spare parts for engines of different kinds of construction machinery and equipment

Engines

For ordering the right engine, we need you to provide us next data:

Machine data

Machine type (Excavator, wheel loader,...):
 Machine mak (Volvo, Cat,):
 Machine model:
 Machine serial number:

Engine data

Engine make (Cummins, Deutz, Volvo, CAT....):
 Engine type:
 Engine power (kW/HP) :
 Engine serial number:

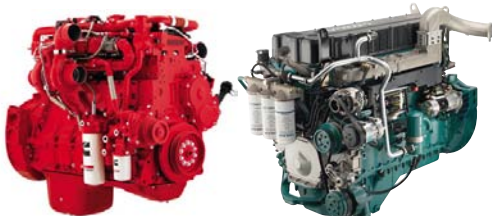

Spare parts for engines

For ordering the right spare part we need you to provide us next data:

Machine data

Machine type (Excavator, wheel loader,...):
 Machine mak (Volvo, Cat,):
 Machine model:
 Machine serial number:

Engine data

Engine make (Cummins, Deutz, Volvo, CAT....):
 Engine type:
 Engine power (kW/HP) :
 Engine serial number:
 Component number on Picture 3

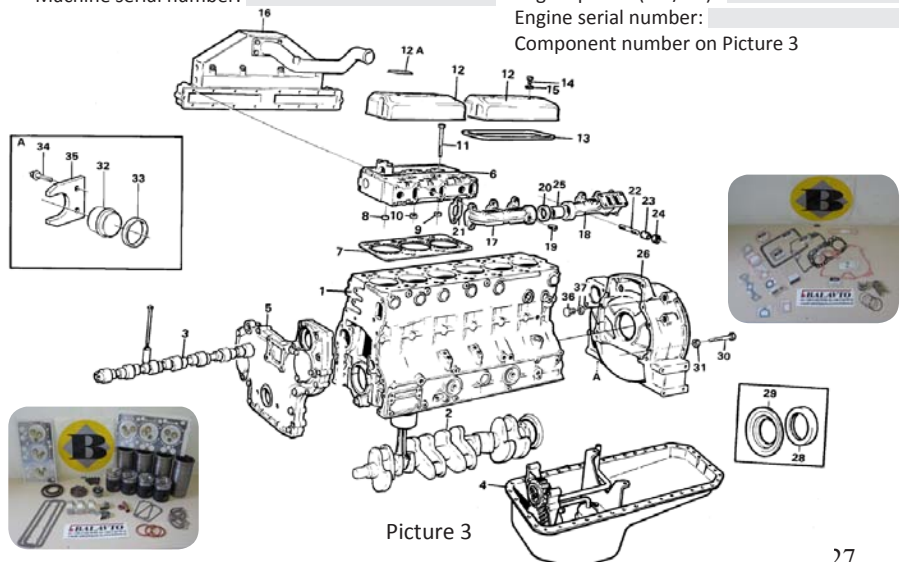

Picture 3

STARTER MOTORS

We can provide different starters for all kinds of machines, trucks, cars ...



Data needed for ordering starter motor

STARTER DATA:

Supplier of actual used starter:
 Typ of starter:
 Serial number:
 Mounting dymensions
 (screw hoses, diameter, number of hoses...):

ENGINE DATA:

Diesel or Petrol:
 No. of cylinders:
 Displacement [l]:
 Related output at [kW/HP]:
 For what kind of machine /vehicle starter needed
 (Excavator, wheel loader , truck, car....):

MACHINE DATA:

Make of machine/vehicle (Volvo, Cat, Mercedes):
 Machine/vehicle model:
 Machine/vehicle serial number:

ALTERNATORS

We can provide different alternators



Data needed for alternator ordering

ALTERNATOR DATA:

Supplier of actual used alternator:
 Typ of alternator:
 Serial number:
 Rated voltage/curent : V, A
 Mounting dymensions
 (screw hoses, diameter, number of hoses...):

ENGINE DATA:

Diesel or Petrol:
 No. of cylinders:
 Displacement [l]:
 Related output at [kW/HP]:

MACHINE DATA

For what kind of machine /vehicle alternator needed:
 Automotive / Commercial vehicles (trucks, buses, ...) / Agriculture /
 Construction / Railway / Marine / Other:
 Make of machine/vehicle (Volvo, Cat, Mercedes):
 Machine/vehicle model:
 Machine/vehicle serial number:

Type of instalation:

Side view

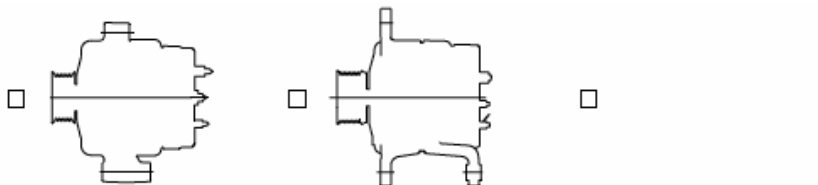

Back side view: Please draw direction,
 position of cables and terminals



Max alternator brackets diameter: mm

Max alternator length: mm

Mounting requirements: To specify on sketch above or enclose drawing or 3D model

HYDRAULIC CYLINDERS

Single acting hydraulic cylinders with piston

Different kinds of hydraulic cylinders for all hydraulic machiners and attachments. If you need any kind of hydraulic cylinder, please contact us!

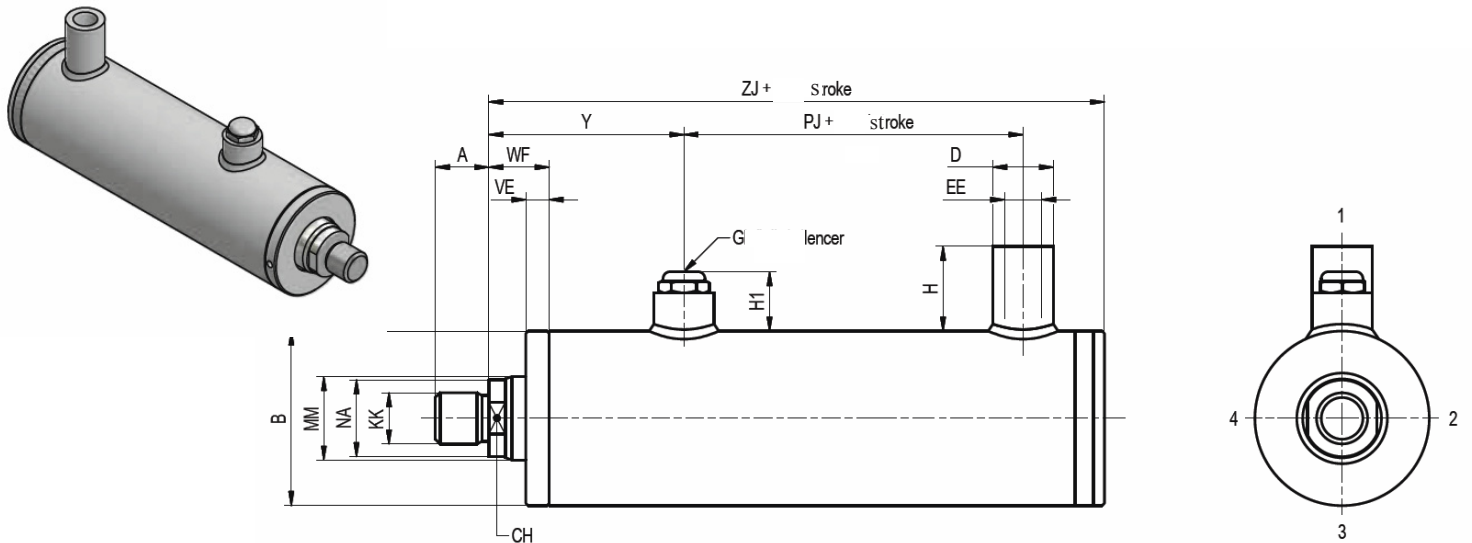

Piston Ø	MM Ø	A	B Ø	CH Ø	D Ø	EE	KK	NA Ø	WF	VE	Y	PJ	ZJ	H1	H*

For ordering the right cylinder, you need to provide us all above stated dimensions - in milimeters. Before ordering cylinder, please fill in the values in the table and send it to us.

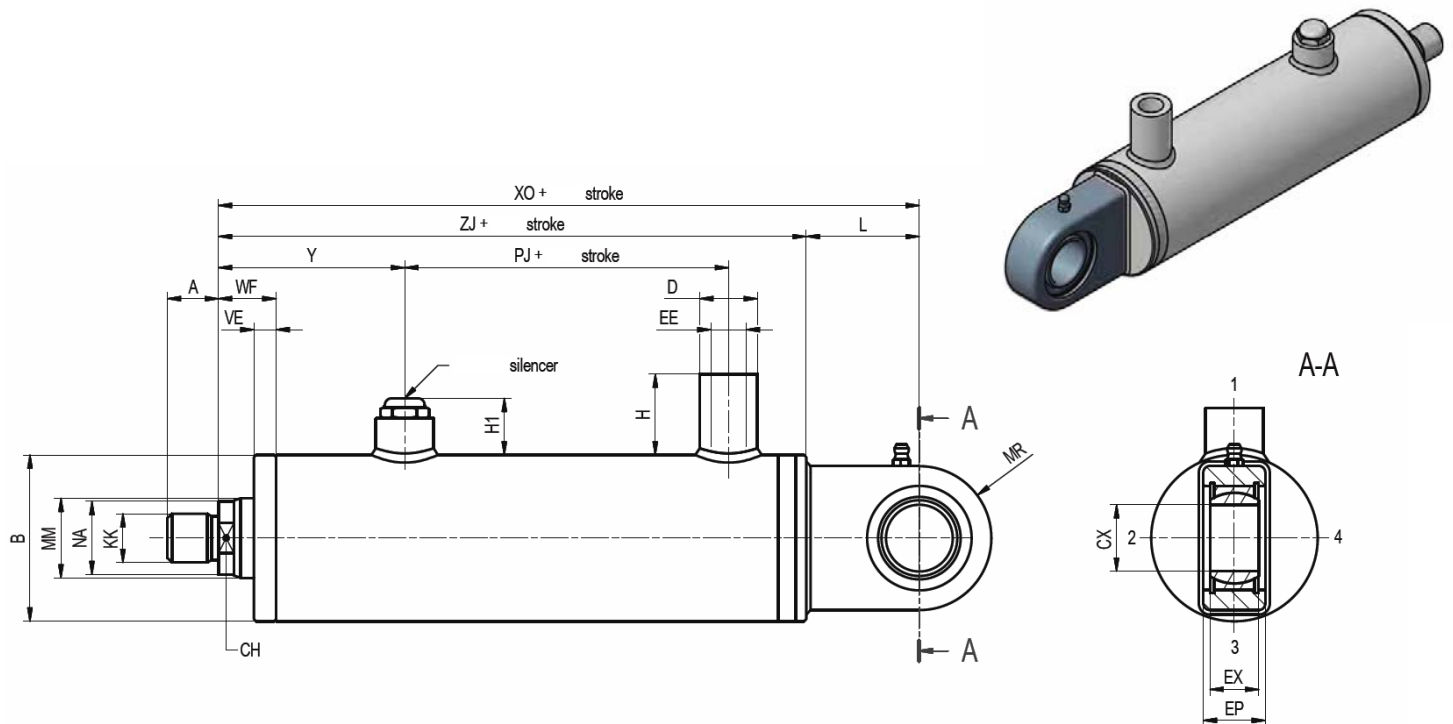

Piston Ø	MM Ø	A	B Ø	CH Ø	D Ø	EE	KK	NA Ø	WF	VE	Y	PJ	ZJ	H1	H*

Piston Ø	XO	L	CX	EX	EP	MR

For ordering the right cylinder, you need to provide us all above stated dimensions - in milimeters. Before ordering cylinder, please fill in the values in the table and send it to us.

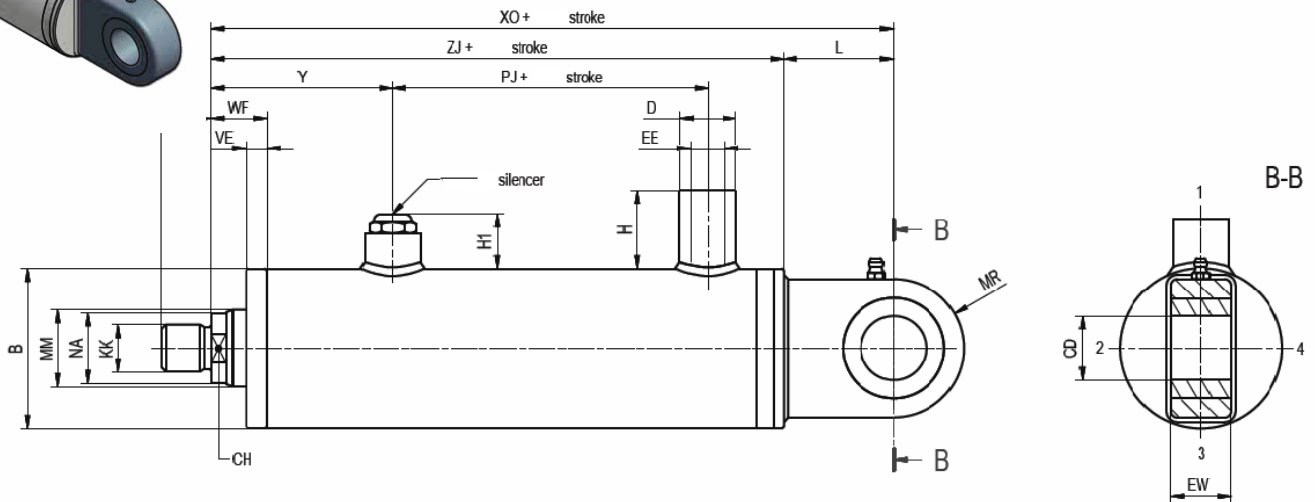
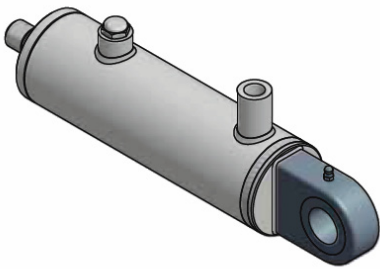

Piston Ø	MM Ø	A	B Ø	CH	D Ø	EE	KK	NA Ø	WF	VE	Y	PJ	ZJ	H1	H*

Piston Ø	XO	L	CD	EW	MR

For ordering the right cylinder, you need to provide us all above stated dimensions - in millimeters. Before ordering cylinder, please fill in the values in the table and send it to us.

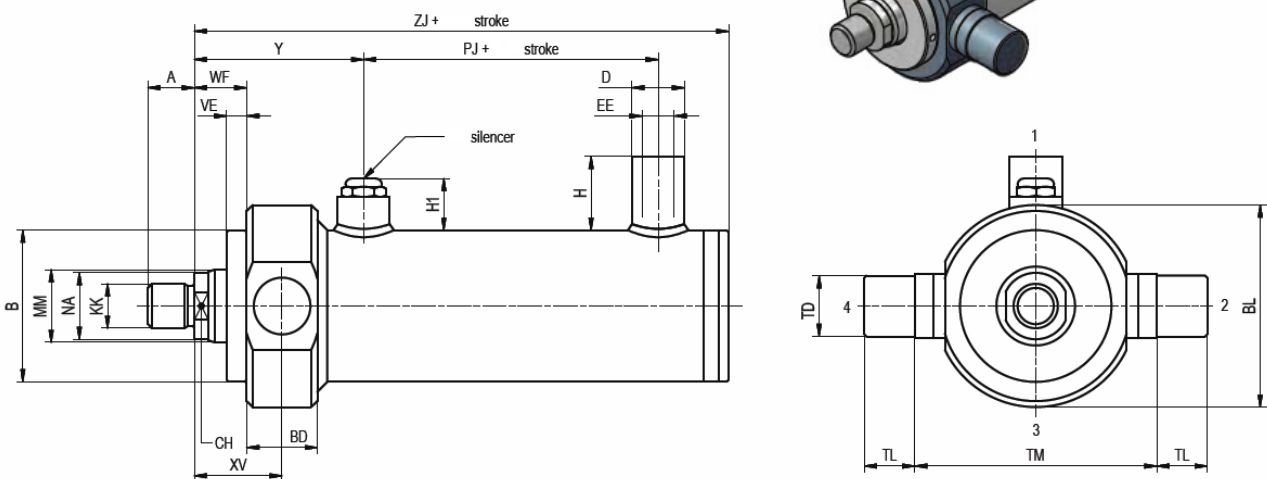
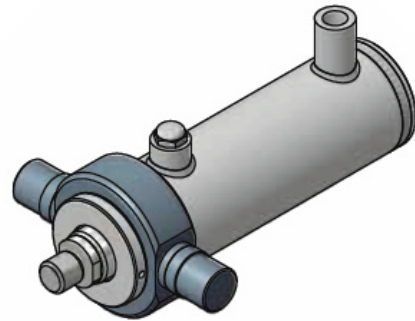

Piston Ø	MM Ø	A	B Ø	CH	D Ø	EE	KK	NA Ø	WF	VE	Y	PJ	ZJ	H1	H*

Piston Ø	XV	BD	TD Ø8	TM	TL	BL

For ordering the right cylinder, you need to provide us all above stated dimensions - in millimeters. Before ordering cylinder, please fill in the values in the table and send it to us.

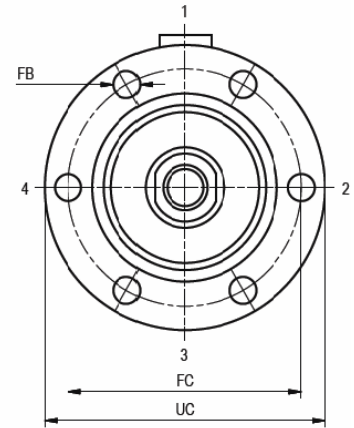
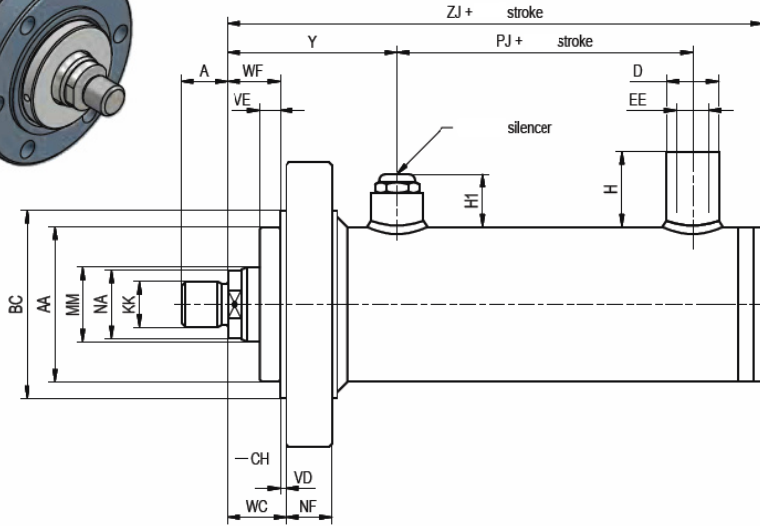
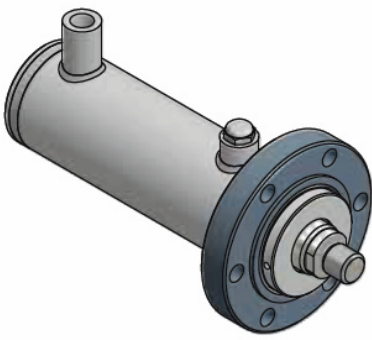

Piston Ø	MM Ø	A	CH	D Ø	EE	KK	NA Ø	WF	VE	Y	PJ	ZJ	H1	H*

Piston Ø	WC	VD	NF	BC Øe8	FC	UC	FB	AA

For ordering the right cylinder, you need to provide us all above stated dimensions - in millimeters. Before ordering cylinder, please fill in the values in the table and send it to us.

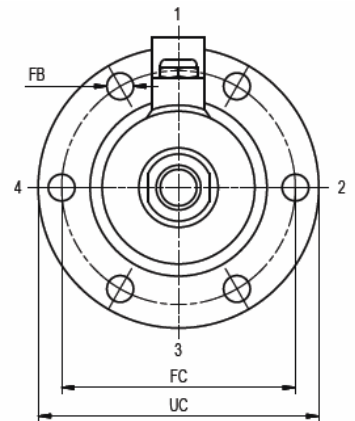
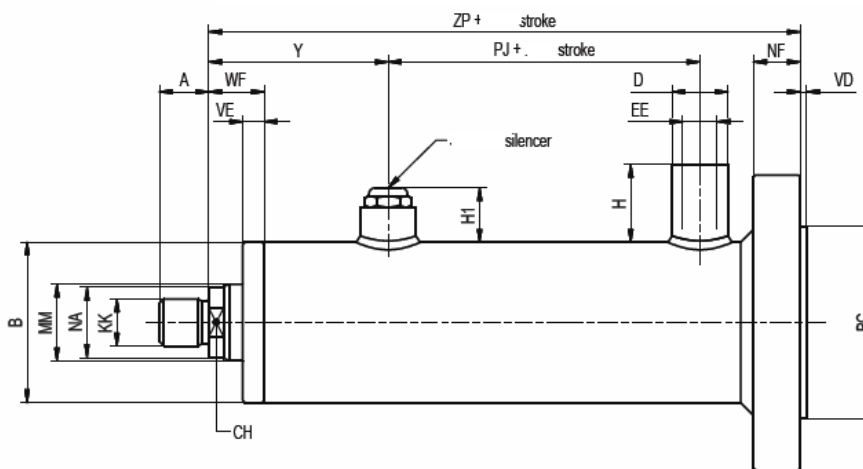
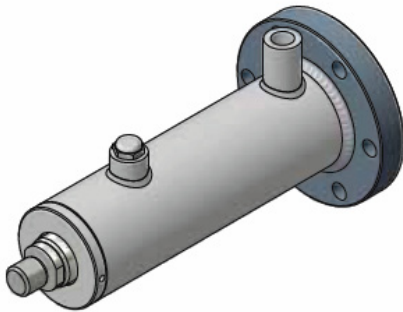

Piston Ø	MM Ø	A	B Ø	CH	D Ø	EE	KK	NA Ø	WF	VE	Y	PJ	ZP	H1	H*

Piston Ø	VD	NF	BC Øe8	FC	UC	FB

For ordering the right cylinder, you need to provide us all above stated dimensions - in millimeters. Before ordering cylinder, please fill in the values in the table and send it to us.

PINS AND BUSHING

In Balavto company we can provide any kind of pins and bushing for your machine.
Most of the pins and bushing we can produce - custom-made. Please contact us for more info.

- Pins and bushing production

We can make all kinds and dimensions of pins and bushings - custom made.

- Pins and bushing replacement

Changing (mounting) the old and wore pins and bushing with a new ones

- Repairing the old and damaged pins and bushing

We repair damaged pins and bushing (in our workshop or on the terrain) and make the original holes



Pins and bushing production - custom made

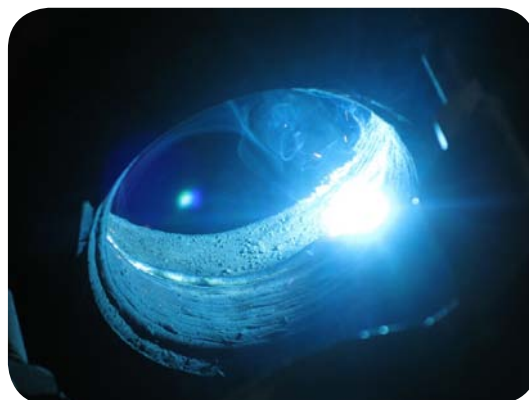

Pins and bushing repairing and mounting them on the machine

USED SPARE PARTS

www.usedspareparts.net



On our web page www.usedspareparts.net you can find used spare parts for all kinds and makes of construction machines: excavators, loaders, articulated haulers - dampers, backhoe loaders, dozers, rollers, stone crushers...

If you can not find the part you're looking for in our base, please contact us and we will find required part for you!

Contact: Tadej Čoha, phone: + 386 5 365 99 14, e-mail: tadej.coha@balavto.si



Engines



Gearboxes



Cabs



Hydraulic Pumps



Hydraulic Cylinders



Electrical Systems



Reducers



Hydraulic Valves



Radiators



Brake Systems



Computers



Rims



Rollers



Seats



Cardans



Links



Excavator Arms



Lights

And many other used and renewed spare parts for all kinds of construction machines: reducers, electrical cables, hydraulic hoses, sensors, cabs, glasses, compressors

UNDERCARRIAGE

Undercarriage Components for different machines

Undercarriage for crawler excavators, dozers, loaders on tracks compact excavators and all other machines on tracks from different manufacturers: Volvo, Komatsu, Liebherr, O&K, CAT, JCB ...



Undercarriage Components for mini excavators

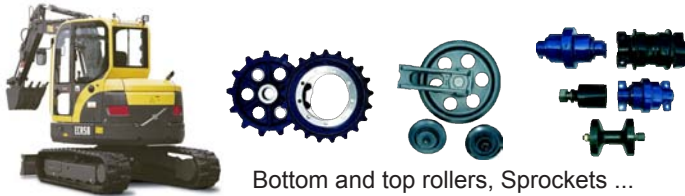

Bottom and top rollers, Sprockets ...

Contact:

Gregor Perhavec Phone: + 386 5 365 99 00
Mob: +386 51 629 782 gregor@balavto.si

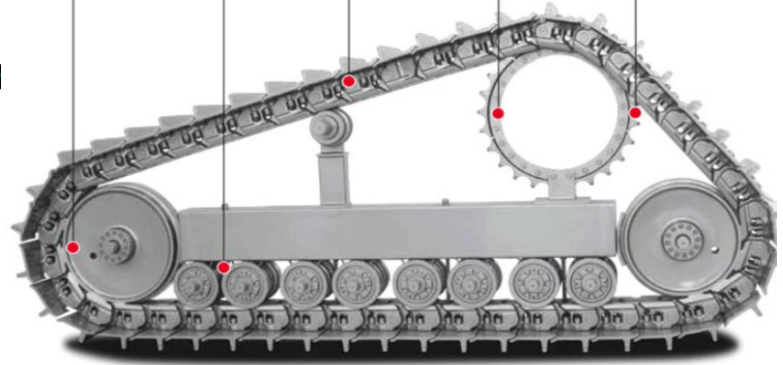

TYRES AND CHAINS

Tyres for wheeled excavators, wheeled loaders and articulated haulers.









Warranty -18 months



Protective Chains

A Tyre Protection Chain is a close mesh of high-alloy, hardened steel chains. It protects the tread and sidewalls of the tyres. The flexible design of the chains let them adjust to every tyre deformation. Their high level of self-cleaning prevents the tread mesh becoming filled and clogged, which contributes to achieving the best possible road-holding and traction.

<p>1. Hexagon chains: Foresty, Snow, Mud, Recycling, Scrap</p>		
<p>2. Square chains: Limestone, Marble, Travertine, Coal, Earth Moving</p>		
<p>3. Traction chains: mud, snow, forest</p>		

RUBBER TRACKS for Mini Excavators

HIGH QUALITY FOR THE GOOD PRICE AND 2 YEARS WARRANTY

High quality rubber tracks of all dimensions for compact excavators from world's best-known manufacturers: JCB, Komatsu, Hitachi, Kubota, Kobelco, Atlas, Gehl, Nissan, Takeuchi, Pel Job, O&K, Volvo, Yanmar...



We have different dimensions of rubber tracks in stock !!!



camoplast

ALUMINIUM PLATFORMS

Always in stock !!!

Different capacity and dimensions of aluminium platforms for loading machines on trailer or a truck!



Automatic Central Lubrication Systems



Sales and installation of high quality systems for automatic central lubrication for excavators, loaders and dumpers.

Advantages of using the system for central lubrication

- Reducing oil consumption up to 50%
- Adjustable and changable lubrication cycles (from the machine cab)
- Lubrication is done automatically, allowing the operator to dedicate to his work
- Lubrication is constant
- Prolongs life of the machine arm, which increases the value of second hand machines



Central Lybrication System unit on the machine



Distribution unit



Central Lybrication System unit

Weighing systems for Loaders

RDS Weighing systems allow easy load weighing on different models of loaders.

By the measurement of hydraulic pressure RDS weighing systems provide easy monitoring of load weight.



You can send and save all your data from RDS System on the computer.

RDS systems for small loaders and fork-lifters



Printing the data



RDS system for big loaders



Control unit in the cab

Other from our Construction Equipment sale program

JOYSTICKS

Sales and installation of joysticks for all types of excavators and loaders.



SEATS

Sales and installation of seats for construction machines and trucks.



TEETH FOR BUCKETS

Teeth for all kinds of buckets



LIGHTS

Working lights, rotation lights and other for all kinds of machines.



OVERALLS

Overalls *Balavto*
Size: 52, 54, i 56



JACKETS

Fur-lined jacket *Balavto*,
different sizes



TRANSPORTATION

In accordance with customers requirements, in Balavto Company we can arrange transportation of machinery to any port in the Eastern Africa.

Contact person: Niko Bajec
tel: +386 5 365 99 00 mobile: + 386 31 381 694
email: niko@balavto.si



WOODEN PRODUCTS

- WOODEN PANELS AND BEAMS
- PLAYWOOD PANELS
- WALL AND CEILING WOODEN
CLADDING PANELS
- SOFTWOOD LUMBER
- GLUED LAMINATED TIMBER
- WOODEN HOUSES

 **BALAVTO**

Balavto Ltd. Ajdovscina
Tovarniška cesta 5b 5270
Ajdovščina, Slovenija, Europe

Phone: +386 5 365 99 00
Fax: +386 5 365 99 23
e-mail: info@balavto.si

Properties:

- The plates are made of three each bonded waterproof layers of fir tree: outer layers are compiled by strips glued across the width
- Placed longitudinally, the middle layer is composed of planks laid transversely which are framed with longitudinal and butt closing slats.
- The quality of surface sticking AW 100 (DIN 68 705), the quality of the entire panel by default ON B 3023
- The plates are protected with melamine resin by hot process (not allowed on the concrete).
- The edges protecting - acrylic facade paint
- Triple bonding reduces the effect of the plate on the minimum
- Large bending strength

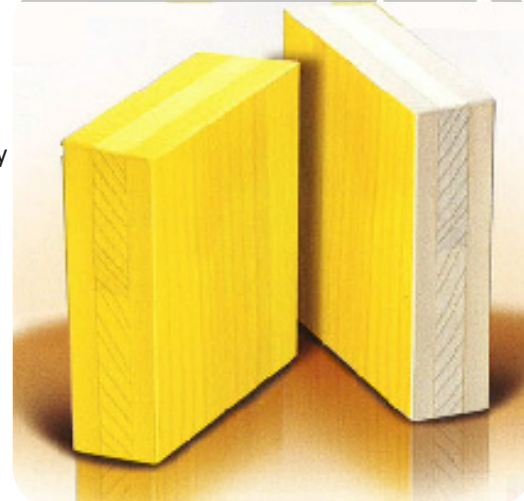
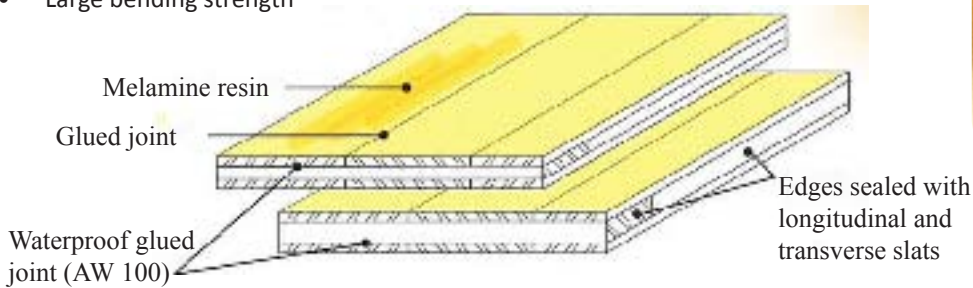

Wood panels 21 and 27

Wood panels



Three-Layer waterproof panel (21)

- Thickness: 21 mm
- Width: 50 cm (wall plate) / 30 cm (pillar plate)
- Length: 100/150/200/250 cm

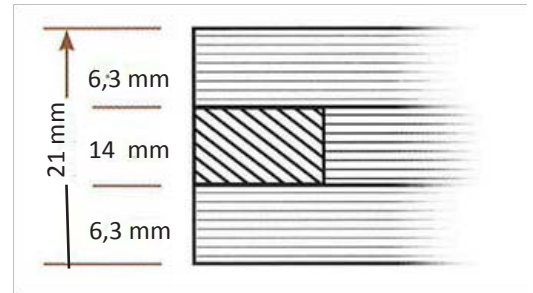

Three-Layer waterproof panel (27)

- Thickness: 27 mm
- Width: 50 cm (wall plate) / 30 cm (pillar plate)
- Length: 100/150/200/250 /300 cm

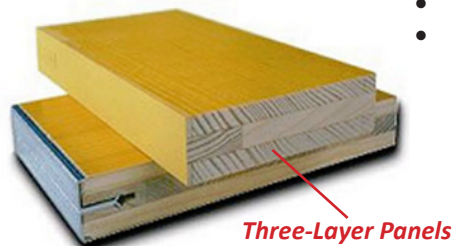
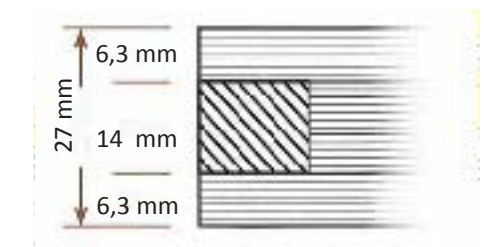

FEATURES OF CROSS SECTION

Panel 21 mm

Cross section: $A = 107 \text{ cm}^2$
Moment of preservance: $J = 41 \text{ cm}^4$
Resistance: $W = 38 \text{ cm}^3$

Panel 27 mm

Cross section: $A = 132 \text{ cm}^2$
Moment of preservance: $J = 77 \text{ cm}^4$
Resistance: $W = 58 \text{ cm}^3$

MECHANICAL PROPERTIES

Panel 21 mm

Bending strenght $\sigma = 6,8 \text{ kN/cm}^2$
Bulk modulus/Modulus of elasticity $E1 = 1058 \text{ kN/cm}^2$
 $E2 = 118 \text{ kN/cm}^2$

Panel 27 mm

Bending strenght $\sigma = 4,5 \text{ kN/cm}^2$
Bulk modulus/Modulus of elasticity $E1 = 1050 \text{ kN/cm}^2$
 $E2 = 80 \text{ kN/cm}^2$

INSTRUCTIONS FOR USE:

- Before the concrete-work the panels are to be thoroughly soaked with water
- After the removal of the formwork the panels must be cleaned immediately, then folded on a flat surface
- To maintain the panels we recommend the use of paraffin oil or paste (also before the first use), which are applied by the manufacturer's instructions.
- The drilling and infiltrating of the panels should be minimal
- We recommend you to abide the instructions for the use, which you get with each panel delivery



PACKAGING:

Pallet:

- a standard of 40 pieces
- stack (27mm) 2 x 50 pieces
- stack, enfolded with PVC foil

The stacks are also made according to customers



BALAVTO

For structuring in construction
Practical carriers with many possibilities

WOODEN BEAMS

- Wooden beams or carrier as a main element of wall plates and mezzanine constructions is of the main importance for the profitability of whole panel system.
- High quality narrow rib with a high procent of artificial resin make the carrier steady and resistant.
- Red caps at the ends of the carriers give optimal protection from damage and extend their lifetime.
- High capacity and strong.
- Light and easy to use.

Wooden beams - carriers H20

Thickness: 20 cm
Width: 8 cm
Lenght: 245/290/330/390/450/490 cm
Weight: 4,8 kg per 1 meter lenght

Contact person: David Puc
tel: +386 5 365 99 00 mobile: + 386 41 265 752
email: david@balavto.si

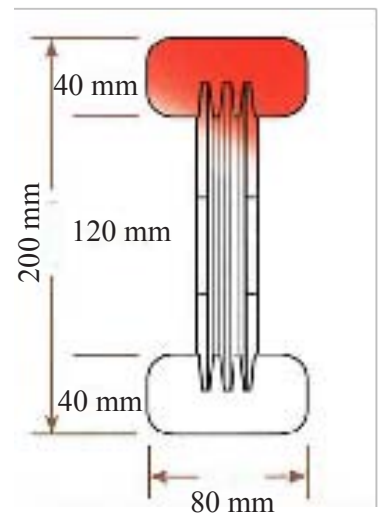

USAGE OF WOODEN PANLES AND BEAMS



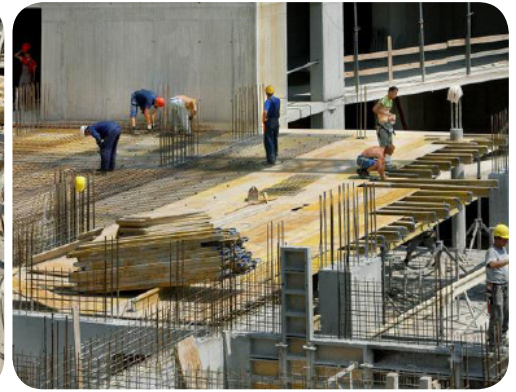
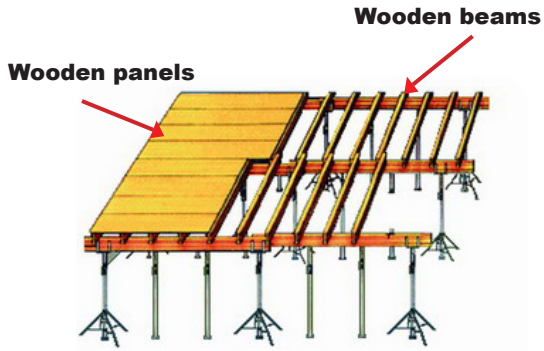













Wooden panles are, because of their low weight, very practical for usage - workers can handle and lift them on higher floors manually.

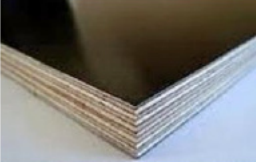

BALAVTO

Wide Range of different thicknesses and sizes of plywood for construction and furniture purposes.

Plywood is a panel made of several layers of veneers of different thicknesses and different tree sorts, glued together with different adhesives. Composition by different tree sorts or a different combination of layers determines usage of plywood.

PLAYWOOD PANELS		
1. Beech Plywood	  	<p>Available dimensions: 2500 x 1250mm</p> <p>Thickness: 4mm, 6mm, 8mm, 10mm, 12mm, 15mm, 18mm</p>
2. Poplar plywood	  	<p>Available dimensions: 2500mm x 1220mm 2520mm x 1250mm 2520mm x 1850mm 3130mm x 2100 / 1850mm</p> <p>Thickness: 3 - 50mm</p>
3. Birch plywood	  	<p>Available dimensions: 1250mm x 2500mm</p> <p>Thickness: 6,5mm, 9mm, 12mm, 15mm, 18mm, 21mm, 24mm, 27mm, 30mm</p>
4. Elliottis plywood	  	<p>Available dimensions: 2440mm x 1220mm</p> <p>Thickness: 9mm, 12mm, 15mm, 18mm, 20mm, 24mm</p>
5. Birch plywood with dark brown fenol cover	 	<p>Available dimensions: 2500mm x 1250mm, 3000mm x 1525mm</p> <p>Thickness: 9mm, 12mm, 15mm, 18mm, 21mm, 24mm, 27mm, 30mm</p>
6. Birch plywood T-fix with antislip dark brown fenol cover	 	<p>Available dimensions: 2500mm x 1250mm, 3000mm x 1525mm</p> <p>Thickness: 9mm, 12mm, 15mm, 18mm, 21mm, 24mm, 27mm, 30mm</p>
7. Special playwoods		<p>Contact person: David Puc tel: +386 5 365 99 00 mobile: + 386 41 265 752</p>

WALL AND CEILING WOODEN CLADDING PANELS

WOODEN WALL AND CEILING CLADDING PANELS - THICKNESS 12, 15, 20 mm

- Natural, without varnish
- Varnished with a transparent varnish
- Varnished with glossy varnish
- Varnished with toning in brown shade
- Varnished with toning in green shade
- Varnished with toning in dark brown shade

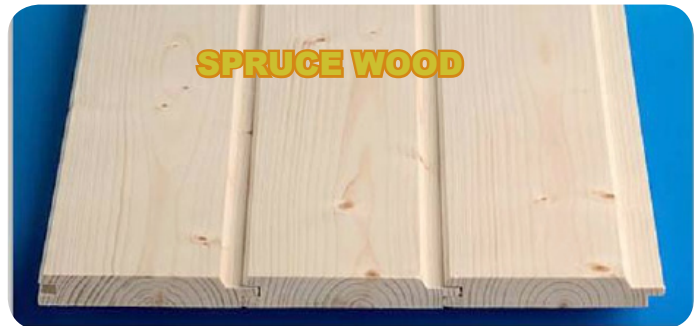

Natural without coating

Available in dimensions:

Width: 95 mm
Thickness (mm): 12, 15, 20



With transparent coating

Available in dimensions:

Width: 95 mm
Thickness (mm): 12, 15, 20



With glossy transparent coating

Available in dimensions:

Width: 95 mm
Thickness (mm): 12, 15, 20



With brown coating

Available in dimensions:

Width: 95 mm
Thickness (mm): 12, 15, 20



With green coating

Available in dimensions:

Width: 95 mm
Thickness (mm): 12, 15, 20



With dark brown coating

Available in dimensions:

Width: 95 mm
Thickness (mm): 12, 15, 20



SOFTWOOD FROM PINE WOOD AND OTHER TREES



DIFFERENT DIMENSIONS OF LENGTHS AND THICKNESS OF MILLED WOOD

FRAMING and BOARDS – long strips of different sizes



The wood is adequately packed and prepared for container transportation



CONSTRUCTION LUMBER IS SUITABLE FOR:

- ROOFING
- WOOD FRAME CONSTRUCTION
- WOOD FOR INDUSTRY



Glued laminated timber as a carriers in construction

Wooden carriers have more advantages than steel or concrete carriers:

- better static characteristics due to low weight of timber
- great opportunities for the different architectural design in varying sizes and shapes
- greater span without columns in between
- better seismic safety
- better fire resistance

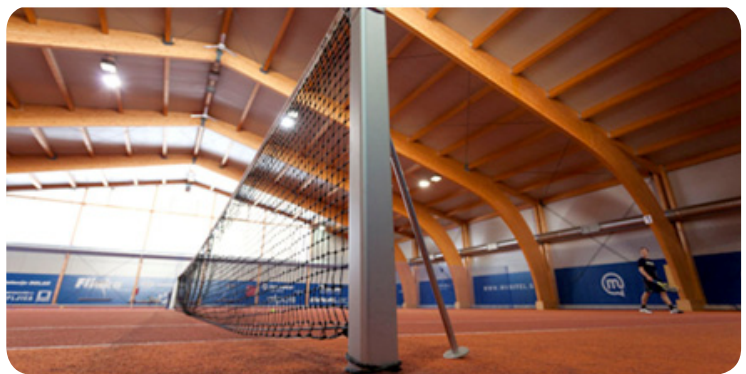

LOW COST WOODEN HOUSES, MADE FROM DIFFERENT KINDS OF WOOD.

Available different sizes and shapes of houses. Prefabricated segments ready for container transportation. Please contact us for more information.

Examples of wooden houses



BEECH HEARTWOOD - SOLUTION**LAMINATE FLOORING**

surface treatment:
finishing coat: Rustic
dimensions: 1292x192x8 mm
flooring structure: Plank
underfloor heating system: Suitable
installation system: Just click

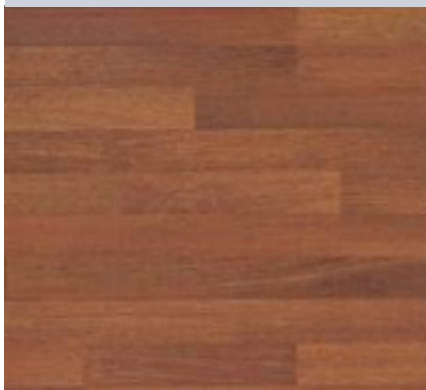
**MERBAU - SOLUTION****LAMINATE FLOORING**

surface treatment:
finishing coat: Rustic
dimensions: 1292x192x8 mm
flooring structure: Plank
underfloor heating system: Suitable
installation system: Just click

**WALNUT PATCHWOOD - SOLUTION****LAMINATE FLOORING**

surface treatment:
finishing coat: Rustic
dimensions: 1292x192x8 mm
flooring structure: Plank
underfloor heating system: Suitable
installation system: Just click



BALAVTO

Balavto d.o.o.
Ajdovščina

Tovarniška cesta 5b
5270 Ajdovščina
Slovenia, Europe

Tel: +386 5 365 99 00
Fax: +386 5 365 99 23
e-mail: info@balavto.si
www.balavto.com



All for your machine in one place:
www.balavto.com

Used spare parts for construction machines:
www.usedspareparts.net