

PENSTOCK DETAIL 150mm - 300mm

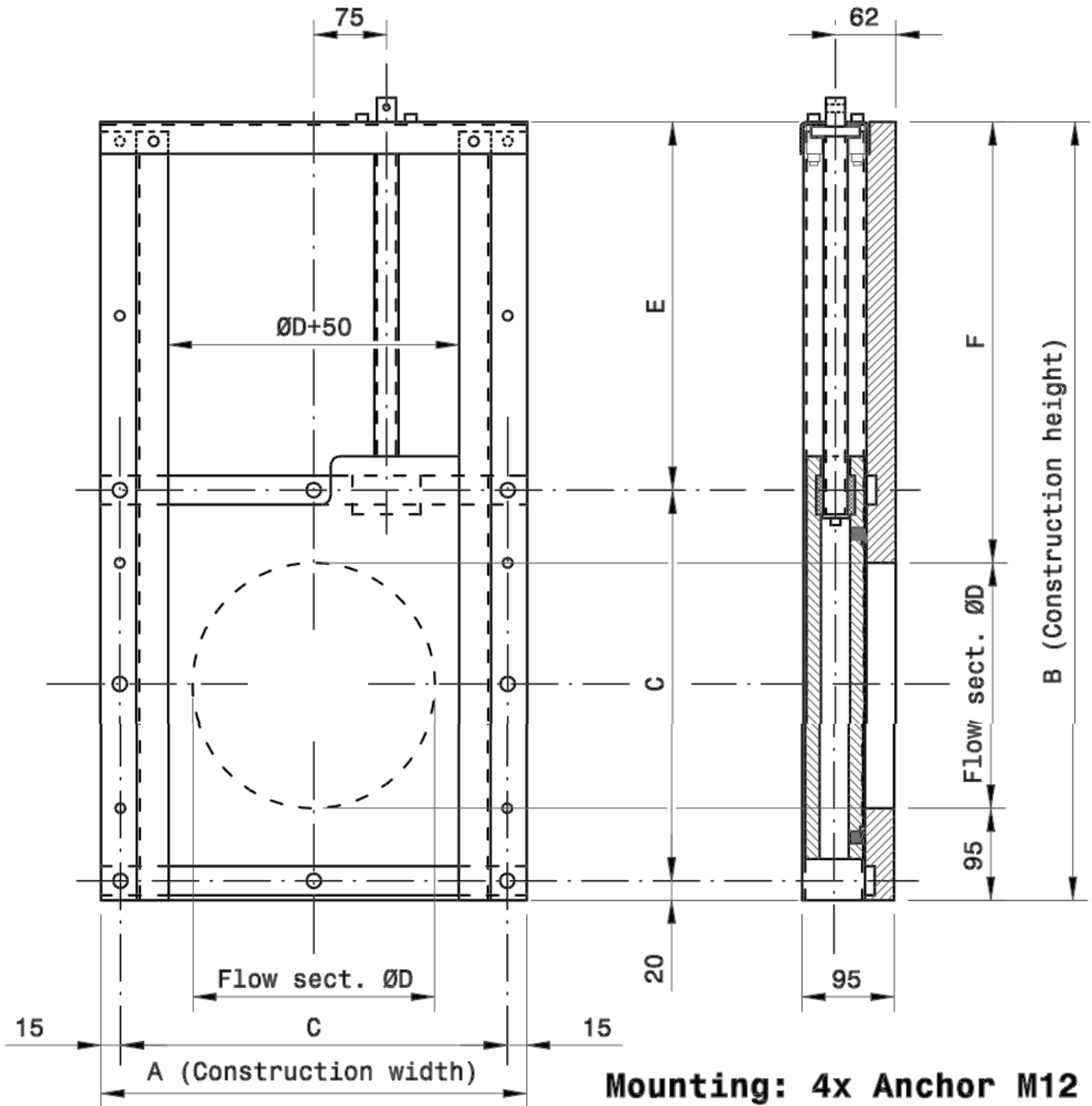

ØD	A	B	C	E	F	Weight
150	340	600	300	280	355	16 kg
200	390	700	350	330	405	22 kg
250	440	800	400	380	455	26 kg
300	490	900	450	430	505	31 kg

Material specification

Slide and seat	- HDPE-300
Spindle TR25x8L.	- RVS AISI316
Frame	- RVS AISI316
Threaded lift block	- POM
Spindle bearing	- PTFE (Teflon)
Sealing	- EPDM
Bolts/Nuts	- A4

PENSTOCK DETAIL 150mm - 300mm

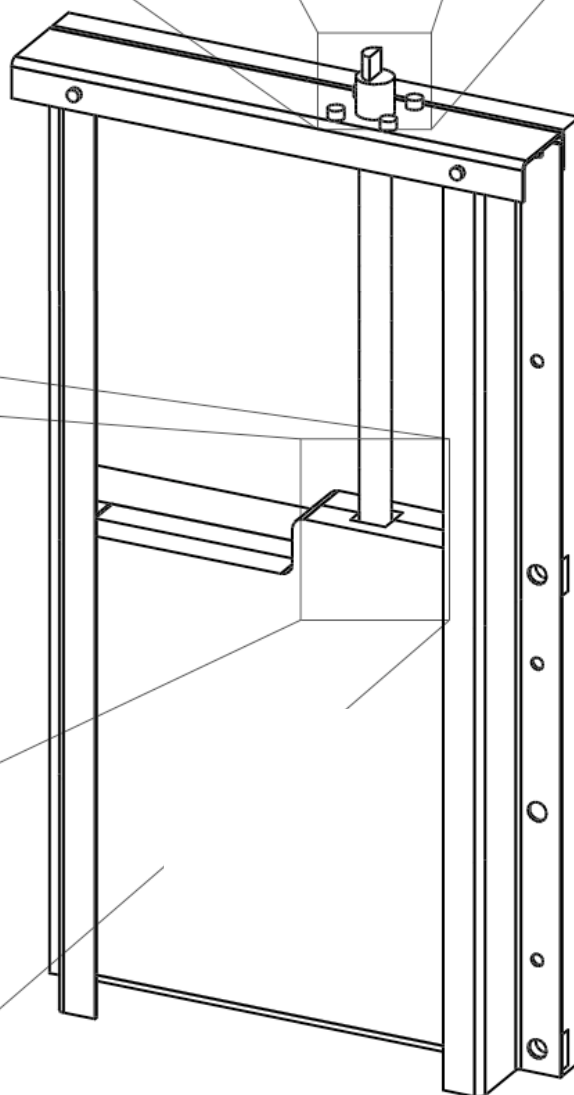
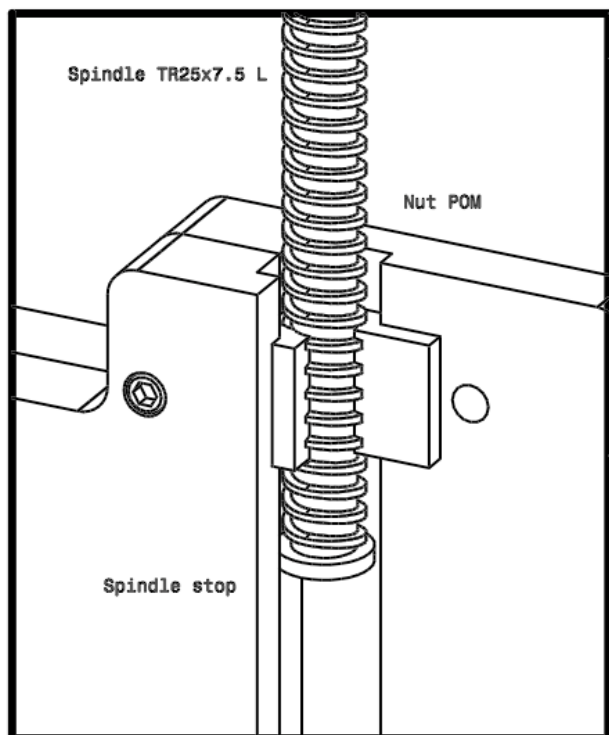
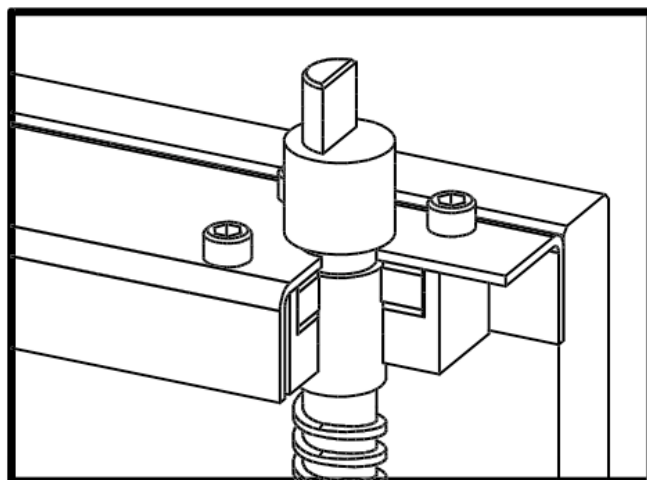
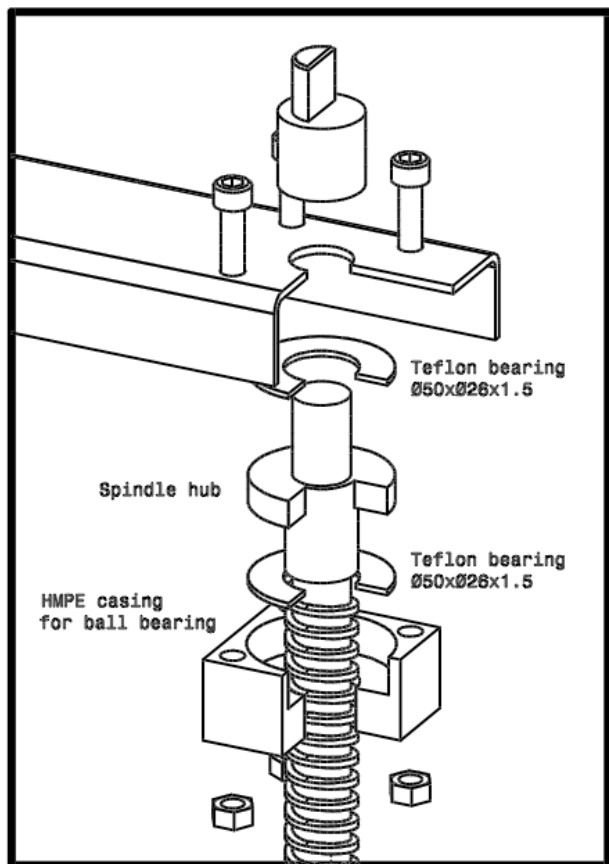

CASTING MOULD TYPE 150MM-300MM

