



PROCEEDINGS OF THE  
**7<sup>TH</sup> RWSN FORUM**  
**“WATER FOR EVERYONE”**  
29 NOV - 02 DEC 2016, ABIDJAN, CÔTE  
D’IVOIRE

Vol. 1: Papers & Films

**PEER-REVIEWED**

*Compiled and Edited by Sean Furey, Skat Foundation  
May 2017*

**skat** Swiss Resource Centre and  
Consultancies for Development

Suggested citation: RWSN (2017) *Proceedings of the 7<sup>th</sup> RWSN Forum “Water for All”, 29 Nov - 02 Dec 2016, Abidjan, Côte d’Ivoire*, Rural Water Supply Network, Skat Foundation, St. Gallen Switzerland. DOI: 10.13140/RG.2.2.23154.50880

## Introduction

### Human Right to Water

## 1.1 Introduction

The 2016 Rural Water Supply Network Forum in Abidjan was the first global gathering to consider the practical challenge of how everyone worldwide can get access to safe, affordable water by 2030. It was also the first RWSN Forum to take place in a francophone country, in the 25 years since the creation of the network.

The Forum gathered 467 rural water sector practitioners from over 300 organisations from 64 countries in Africa, Asia, Americas, and Europe, in a bilingual (English/French) four day event. It was opened by the Prime Minister of Côte d'Ivoire, Mr Daniel Kaplan Duncan. We were joined by HE State Minister James Dengchol Tot, Minister of Water, Irrigation and Electricity of Ethiopia, as well as a delegation from AMCOW.

So what did we learn? A lot, but we did not reinvent the wheel. Ensuring sustainability of water supplies in rural areas is still challenging, but we are finding new, sophisticated ways of managing and monitoring water services; self-supply, a term which was only barely existed a decade ago, was one of the big discussion points of the week; presentations on topics related to equity, non-discrimination and inclusion, as well as financial sustainability, emphasized that subsidies are no longer a dirty word in the rural water sector and that we need them to reach the most disadvantaged segments of the population. And while many professionals in the sector are keen to see more funding go to rural water services, we also found out that few of us actually know how much is being spent in his or her country on WASH.

We would like to think that aside from the learning experience, many of us also had a chance to make meaningful connections with other participants, be it at the Rock café, the ICT Marketplace, the exhibition, during the coffee breaks or the cocktail party. Perhaps some of you even met some of the RWSN members whose contributions you read regularly. This is the strength of the RWSN Forum — access to a collective of 4000 person-years of delegate experience to make water for everyone a reality.

HOSTED BY



SUPPORTED BY



Conrad N. Hilton  
FOUNDATION



skat Swiss Resource Centre and  
Consultancies for Development



ICEX España  
Exportación  
o Inversiones



CARITAS



## RWSN Forum objectives

### Human Right to Water

## 1.2 RWSN Forum objectives

The 7th RWSN Forum provides a platform to improve rural water supplies by learning from one another. We recognise that nothing can replace face-to-face communication. The RWSN Forum, held every five years, is a key event in bringing rural water supply professionals and practitioners together to share their knowledge.

The objectives of the 7th RWSN Forum are to enable delegates—political leaders, government staff, NGOs, donors, academics, think tanks, private enterprises and civil society—to share, learn, and ultimately improve water supplies in the areas that they work in. The Forum emphasises learning and sharing rather than showcasing, and has a practical rather than a political focus. Political leaders who participate are encouraged to engage in the sessions and exhibition as equals with others.

## 1.3 Open Call & Peer Review

For RWSN it is essential that this conference is a Forum that is open to anyone with experiences to share on rural water supplies. We also see the Forum as opportunity to strengthen the documentation of what is happening across the sector, because too often, good work goes under-recorded, and quality of evidence is not challenged. Therefore, from January 2016 onwards we promoted an open call for submissions, either as short or long papers, posters, films or even illustrations and photos. In total we receive 255 submissions from all over the world, from all different types of individual and organisations—though more from water users and community organisations would have been welcomed and more emphasis in reaching out to this important demographic will be considered next time. 192 submissions were accepted through peer-review, though not all authors were able to attend, and some failed to submit a final version. However, the result is a rich knowledge resource that was presented at the Forum and is available online for future reference.

We are grateful to all the experts that made time to review submissions and write constructive feedback for authors:

Adank, Ms Marieke (IRC)  
Adekile, Mr Adedotun (Water Surveys and Resources Development Limited)  
Annis, Mr Jonathan (Tetra Tech)  
Armstrong, Mr Andrew (Water Mission)  
Brocklehurst, Ms Clarissa (Consultant)  
Butterworth, Dr John (IRC)  
Carpenter, Mr Jacob (Independent WASH Consultant)  
Carter, Prof. Richard (Richard Carter and Associates Ltd)  
Cavill, Dr Sue (Waterlines)  
Cronk, Dr Ryan (The Water Institute at UNC)  
Danert, Dr Kerstin (Skat Foundation)  
Daw, Mr Raj Kumar  
Fonseca, Dr Catarina (IRC)  
Foppen, Dr Jan Willem (UNESCO-IHE)  
Furey, Mr Sean (Skat Foundation)  
Gesti Canuto, Mr Jose (UNICEF)  
Gomme, Mr Joe (ESI Ltd)  
Gosling, Ms Louisa (WaterAid)

## Open Call & Peer Review

### Human Right to Water

Jimenez, Dr Alejandro (Stockholm Water Institute)  
Jordan, Dr Elizabeth (USAID)  
Johnston, Dr Richard (WHO)  
Kome, Ms Antoinette (SNV)  
Kone, Dr Brama (Centre Suisse de Recherches Scientifiques en Côte d'Ivoire & Université Péléfro Gon  
Coulibaly of Korhogo (Côte d'Ivoire))  
Leclert, Ms Lucie (Caritas Switzerland)  
MacCarthy, Dr Michael (Mercer University)  
Marks, Dr Sara (Eawag)  
Meerman, Ms Robert (RAIN)  
Montangero, Dr Agnes (Helvetas/Swiss Intercooperation)  
Müller, Mr Kim (Caritas Switzerland)  
Nabunnya Mulumba, Ms Jane (IRC)  
Normand, Mr Olivier (International Secretariat for Water)  
Olschewski, Mr André (Skat Foundation)  
Parker, Dr Alison (Cranfield University)  
Pearce, Mr Joseph (IRC)  
Rainey, Dr Rochelle (USAID)  
Robertson, Ms Amanda (USAID)  
Roaf, Ms Virginia (Consultant)  
Saladin, Mr Matthias (Skat Foundation)  
Schweitzer, Dr Ryan (Aguaconsult)  
Smits, Mr Stef (IRC)  
Smets, Ms Susanna (World Bank)  
Tajuddin, Dr Nor Azlin (International Islamic University Malaysia)  
Tindimugaya, Dr Callist (Directorate of Water Resources Management, Ministry of Water and Environ-  
ment, Uganda)  
Wilbur, Ms Jane (WaterAid)  
Willetts, Dr Juliet (Institute for Sustainable Futures, University of Technology Sydney (ISF-UTS))  
Woldearegay, Dr Kifle (Mekelle University)

All materials, plus presentations are available online at <https://rwsn7.net/content/>

Open Call & Peer Review

Human Right to Water

## 2 CONTENTS

<b>1.1</b>	<b>Introduction</b>	<b>2</b>
<b>1.2</b>	<b>RWSN Forum objectives</b>	<b>3</b>
<b>1.3</b>	<b>Open Call &amp; Peer Review</b>	<b>3</b>
<b>2</b>	<b>CONTENTS</b>	<b>5</b>
<b>3</b>	<b>PAPERS</b>	<b>9</b>
<b>3.1</b>	<b>EQUITY NON-DISCRIMINATION AND INCLUSION (ENDI)</b>	<b>9</b>
	RWSN Equality, Non-discrimination and Inclusion Group: A synthesis of experiences and lessons discussed, 2015	9
3.1.1	Human Right to Water	19
	Driving Change: Piloting a Human Rights: Based WASH project in Bangladesh	19
	Agir pour une meilleure réalisation des droits à l’eau à Tienfala	23
	Achieving systemic change in WASH through the Human Rights Based Approach	27
3.1.2	Universal Access & the Hard to Reach	33
	Achieving universal and equitable access to water, sanitation and hygiene (WASH) for all – practitioner perspectives and perceptions	33
	Inclusive Water Supply and Sanitation Services Provision for Indigenous Peoples in Latin America and the Caribbean	41
	Assessing water service coverage by placeholders: a social media simulation	49
	Supporting sustainable WASH services in difficult operating environments: A case study from Nicaragua	63
	Investisseur gestionnaire : une approche pour un service durable de l’eau potable à Madagascar	73
	Social cases: Reaching Universal Access to Water Supply at Community Level	79
	Rights to water and sanitation for People with Disabilities in Madagascar	84
3.1.3	Citizen Empowerment & Inclusion	87
	Bollywood Power: Using films and celebrities to talk water	88
	Closing the Equity and Inclusion Gap for Water and Sanitation: Lessons from Wakiso Health Improvement Project for Elderly and people with disabilities in Namayumba and Kakiri Sub-county, Wakiso District	92
	Capacity building to couples for community and women empowerment and effective and efficient implementation of WASH approaches: The case of the Amhara Integrated Rural Water, Sanitation and Hygiene Project, Ethiopia	96
	Co-production of community managed operations and maintenance: taking a critical view on rural water schemes in Ethiopia	101
<b>3.2</b>	<b>SUSTAINABLE GROUNDWATER DEVELOPMENT</b>	<b>112</b>
3.2.1	Professionalising Drilling & Manual Drilling	112
	Registration of groundwater consultants in Uganda: rationale and status	112
3.2.2	Pump Technologies – Solar and Hand-powered	116
	It is time for the problem of pump corrosion and consequent failure to be eliminated	116
	Piloting of an Innovative Deep-Reaching and Reliable Hand Pump in Africa for Rural Water Access: The LifePump	129
	What cost a forgotten History? Implications of Groundwater Quality on Hand Pump Standardisation in Uganda	143
	Preliminary results from an evaluation of the Blue Pump in Turkana, Kenya	150
	Poste d’Eau Autonome Solaire versus Pompe à Motricité Humaine Un pas décisif vers le robinet à la maison ?	158
	Replacing Type “B” Bush Pumps With Solar Powered Pumps For Rural Water Supply	164

## Open Call & Peer Review

### Human Right to Water

Solar pump technology: programming insights for sustainable rural water supply	172
3.2.3 Groundwater Resources & Hydrogeology	177
Mapping of suitable zones for manual drilling. An overview of the method and the application as decision tools	177
Properties of shallow thin regolith aquifers in sub-Saharan Africa: a case study from northwest Ethiopia	186
Inexpensive Resistivity Instruments for Groundwater Exploration: Experiences of African National Geophysical Teams	192
Gestion quantitative et qualitative des ressources en eau dans la plaine alluviale de Karfiguéla à l’aide d’un SIG : Etude de la recharge induite de la nappe et sa vulnérabilité à la pollution	201
Conception et élaboration de cartes hydrogéologiques au 1:500 000 et 1:200 000 des régions nord et est du Tchad et gestion des ressources hydriques	229
Nurturing Water: Ancestral Ground Water Recharging in the Americas	233
<b>3.3 SUSTAINABLE SERVICES</b>	<b>247</b>
3.3.1 Rural Water Supply Sustainability	247
Searching for sustainability of rural water supply: a snapshot of perspectives of 14 countries across Asia	247
Measuring the impact of multiple-use water services in Tanzania and Burkina Faso: water service quality, nutrition, and health	264
Assessment of Sustainability of Rural Water, Sanitation and Hygiene Interventions in Rwanda	270
Elicitation of Determinants of Rural Households’ Water Supply in Côte d’Ivoire: A Case Study	278
3.3.2 Professionalisation of Rural Water Service provision	287
The need for capacity development to enhance rural water supply and sanitation service delivery: The RWSSC/JICA Approach in Nigeria	287
De la théorie à l’Opérationnalisation de la Reforme de la gestion des Services d’Eau	294
Sustainability Services through Quality Design & and Construction plus effective Operation & Maintenance	298
Customers in focus: Strengthening social and financial sustainability of small town water supply in Northern Vietnam	303
Professionalizing Drinking Water Service Delivery in Small Towns of Haiti	308
Regional water supply to ensure basic services in rural areas of South Africa – what is required, what works, what are the challenges?	312
3.3.3 Finance & Lifecycle Costing	319
Financing WaterCredit to enhance access to water and sanitation for attainment of SDGs	319
Lessons from using the life-cycle costs approach for rural water supply in DRC through the DRC WASH Consortium	337
A Suite of Tools to Support a Systems-Based Approach to Sustainable Management of Water Service Delivery	342
Towards building a tariff methodology for rural water and small Service providers in Colombia	353
Improving Service Sustainability of Electric Pump Systems in Rural Timor-Leste	357
Water User Committees using Village Savings and Loans Association for Sustainable O&M of their Water Facility	381
3.3.4 Government, Decentralisation & Governance	388
Implementing the right to water - water policy choices with decentralised politics in Kenya	388
Experiencias locales en la gestión del agua: Gobernanza del agua y gestión integrada de los recursos hídricos promovida por mancomunidades de municipios de Bolivia	393
Le renforcement des capacités et de la gouvernance locales au service de la durabilité des services d’eau en région rurale- étude de cas du projet Burkina Faso de One Drop	403
3.3.5 Private Sector, Public-Private Partnerships (PPPs), Public-Private-NGO Partnerships	411
FundiFix: exploring a new model for maintenance of rural water supplies	411
Public Private Partnership for Rural Water Supply: Experiences from Zimbabwe	416
A systems approach to sustainable water operation & maintenance in Uganda	427
Steps to Sustainability: Public-Private Partnership in WASH	432

## Open Call & Peer Review

### Human Right to Water

Sustainable WASH Services for Complex Emergency Countries: Approaches from the Central African Republic	442
Providing handpump spare parts within 24 hours through the private sector	449
Pour des MAEP Multi-villages : cas du Niger et expérience de SWISSAID	453
Can PPCPs Improve Water Services Delivery in Rural Areas? Insights from Kenya	459
<b>3.3.6 Community Managed Supplies</b>	<b>465</b>
Towards Achieving A Sustainable Community-led Rural Water Supply Management Model in Zambia: Strides or Rhetoric?	465
Renforcement de la résilience des communautés rurales à travers la mise en œuvre de l’approche « sécurisation des ressources en eau »	475
Sharing Experiences in Implementing a Community Based Water Supply Schemes in Post conflict Areas in Sri Lanka	486
Making systems work: Local government approaches to improving WASH service delivery in Malawi	491
Community management in Malawi: part of the sustainability problem, not the solution	495
<b>3.4 ACCELERATING SELF SUPPLY</b>	<b>500</b>
<b>3.4.1 Progress in accelerating Self-supply</b>	<b>500</b>
Towards 2030 - Trends in rural water supply and the essential inclusion of Self-supply to achieve SDG targets	500
A business case for supported Self-supply as service delivery approach to achieve SDGs	514
Supported Self-supply – learning from 15 years of experiences	521
Establishing a baseline for Self-supply Acceleration in seven Ethiopian woredas	536
<b>3.4.2 Financing &amp; scaling-up affordable rural water technologies</b>	<b>548</b>
Les technologies eau à faible coût dans le nord du Mali: des leçons apprises dans un contexte complexe (2006-2015)	548
Low-Cost Household Groundwater Supply Systems: Pitcher Pump Systems and EMAS Technologies	559
Multiple Use of water Services (MUS) – water for the home and for farming	572
<b>3.4.3 Technology Applicability Framework (TAF) experiences</b>	<b>576</b>
Supporting service delivery and business innovation through TAF application	576
Technology Applicability Framework: Cases from Uganda for WASH Technology validation and uptake	583
Using the Technology Applicability Framework (TAF) to improve sustainability of rural WASH supplies in Nicaragua	591
<b>3.4.4 Entrepreneur professionalisation and capacity development</b>	<b>595</b>
The SHIPO and Mzuzu drill method. Two low cost and locally produced hand drilling technologies for tube wells to 50 metres deep.	595
The SMART Centre Approach: training the private sector and scaling-up Self-supply via through a sustainable business model.	602
Impact of SMART Centres to accelerate Self-supply in rural water services. An example from Tanzania	607
<b>3.5 MAPPING AND MONITORING</b>	<b>612</b>
<b>3.5.1 Monitoring Systems</b>	<b>612</b>
WaterAid’s approach to support national and subnational WASH service monitoring processes: lessons learned to inform future work	612
Introducing ICTs for WASH monitoring in Ethiopia	624
Implication des élus dans le suivi de la gestion du service public d'eau potable au Sénégal	634
The “Rural Water Supply and Sanitation Information System” (SIASAR) – Addressing Sustainability Gaps Through Visual Data in Latin America	639
<b>3.5.2 Water Point Mapping</b>	<b>654</b>
Water Point Mapping in Tanzania: Making the voices of data collectors audible	654
Bigger Data : Water For People's Lessons, Doubts and Experience of Mapping Rural Water Supply Systems In Malawi	664
<b>3.6 RAINWATER HARVESTING &amp; SAND DAMS</b>	<b>670</b>

## Open Call & Peer Review

### Human Right to Water

3.6.1	Rainwater Harvesting	670
	Difficulties in replicating success stories: The case of Domestic Rainwater Harvesting	670
	Using the Revolving Fund Approach to Scale-Up Rainwater Harvesting in Uganda	676
	Transformation with technology- The story of a pilot rainwater-harvesting and Community-Based Climate Change Adaptation project in Rwanda.	682
	Water Catchment management through a 3R approach- Case of RWAMBU Catchment-Western Uganda	696
3.6.2	Sand Dams	701
	Mainstreaming Water Security through Rainwater Harvesting (Sand dam)	701
	Practical recommendations to prevent, restore and rehabilitate silted-up sand storage dams in arid and semi-arid areas	708
	The potential for sand dams to increase the adaptive capacity of East African drylands to climate change	722
<b>3.7</b>	<b>WATER QUALITY, SAFETY AND TREATMENT</b>	<b>730</b>
3.7.1	Water Quality & Water Safety	730
	A Microbial Analysis of Water in Sand Dams and Associated Abstraction Methods	730
	Enrichment of iron in the Gannoruwa well field: Causes and pathways	747
3.7.2	Water Treatment technologies and business models	754
	Traitement et bonne conservation de l'eau à domicile grâce au "Chlore'C". Étude de cas d'une entreprise sociale en Guinée	754
	Access is not enough: ensuring water stays safe in the home with Dispensers for Safe Water	760
	Funding chlorine dispensers for community water supply through carbon finance	766
	Springhealth and the Paise-Economics: the challenge to make the last mile distribution of safe water profitable	770
<b>4</b>	<b>FILMS</b>	<b>776</b>
	A borehole that lasts for a lifetime	776
	Drilling: the importance of borehole siting	776
	ECOLES BLEUES	776
	Entrepreneurs for Water & Water for Entrepreneurs (E4W & W4E)	776
	Evaluating water safety for supply schemes in remote areas. Novel approaches to comply with SDG 6.1 in rural Nepal	776
	Four Steps to Better Drilling Contracts / Quatre étapes pour de meilleurs contrats de forage	776
	FundiFix in Kenya	776
	Mini-Réseaux Solaires – Une eau de proximité, Bénin [273]	776
	Searching for sustainability of rural water supply: a snapshot of perspectives of 14 countries across Asia	776
	Sustainable WASH Services for Complex Emergency Countries: Approaches from the Central African Republic	777
	The power and potential impact of sand dams	777
	Traitement et bonne conservation d'eau à domicile en Guinée	777
	Transformation des puits à grand diamètre au Bénin	777
	Ukraine: Way Towards Good Governance in Rural Water Supply	777
	Water Well Design and Construction Quality	777



## EQUITY NON-DISCRIMINATION AND INCLUSION (ENDI)

### Human Right to Water

## 3 PAPERS

# 3.1 EQUITY NON-DISCRIMINATION AND INCLUSION (ENDI)

---

## RWSN Equality, Non-discrimination and Inclusion Group: A synthesis of experiences and lessons discussed, 2015

---

Type: Long Paper

**Authors** Jane Wilbur, Equality, Inclusion and Rights Advisor, WaterAid, UK ([janewilbur@wateraid.org](mailto:janewilbur@wateraid.org) 0044 (0)20-7793-4567); Ray Norman (World Vision); Chelsea Huggett (WaterAid)

### Abstract/Summary

In 2015 the Rural Water Supply Network's Equality, Non-discrimination and Inclusion theme led e-discussions and webinars on Reducing Inequalities in water, sanitation and hygiene (WASH). This covered *practical approaches to improve participation of everyone; inclusive infrastructure designs and information, guidance and support* that exist on these. Disability, gender, menstrual hygiene management, rights to water and sanitation and school WASH were covered, with experiences shared from West, East and Southern Africa, South Asia, Southeast Asia and Central America. E-discussion participants were encouraged to primarily focus on rural water supply, with sanitation and hygiene being considered when relevant. This report synthesises the online discussions, captures practical tools, draws on relevant content from the webinars and highlights experiences and lessons learnt. It is not an extensive literature review, but does draw lightly on existing literature beyond what was discussed during the e-discussions.

### Introduction

During October and November, 2015 the Rural Water Supply Network's Equality, Non-discrimination and Inclusion (ENDI) theme enjoyed lively e-discussions and two webinars on Reducing Inequalities in water, sanitation and hygiene (WASH). These covered *practical approaches to improve participation of everyone; inclusive infrastructure designs* and the *information, guidance and support* that exist on these. Two webinars on Reducing Inequalities in WASH were held. Presentations focused on disability, gender, menstrual hygiene management, rights to water and sanitation and school WASH in Mali, Niger, Tanzania, Nepal, Ghana, Timor-Leste and Vietnam. During the e-discussions participants shared experiences of working in Uganda, Vietnam, Mali, Zambia, Nepal, Chad, Timor Leste, Tanzania, Niger, Honduras and Pakistan. Throughout the e-discussions and webinars the primary scope was rural water supply, but sanitation and hygiene were considered when relevant.

This report is a summary of the synthesis of experiences and lessons discussed in the RWSN ENDI Group during the e-discussions and webinars (Wilbur et al, 2016). This report is not an extensive literature review, but does draw on existing literature beyond what was discussed during the e-discussions. When done, this is clearly referenced in the text.

*Defining 'inequalities'*

## EQUITY NON-DISCRIMINATION AND INCLUSION (ENDI)

### Human Right to Water

Before the e-discussions and webinars, members of the ENDI theme defined ‘inequalities’ by drawing on the Equality Checklist in Table 1 (Satterthwaite et al, 2012). The Equality Checklist is a useful tool which allows for a more nuanced understanding about which groups and individuals may face inequalities. The inequalities captured in the Checklist are not exhaustive and could be added to. The Checklist authors did not intend for each inequality to be addressed in every target and indicator. Instead, it helps actors to assess the most relevant areas where discrimination and inequalities are present in the given context.

**Table 1 Equality Checklist (Satterthwaite et al, 2012)**

When examined as a whole, do the goals, targets and indicators:

- **Prioritize basic access and focus on progressive realization toward safe and sustainable WASH for all, while reducing inequalities?**
- **Address spatial inequalities, such as those experienced by communities in remote and inaccessible rural areas and slum-dwellers in (peri-) urban areas?**
- **Focus on inequalities, shining the light on the poorest of the poor?**
- **Address group-related inequalities that vary across countries, such as those based on ethnicity, race, nationality, language, religion, and caste?**
- **Attend to the impacts of individual-related inequalities that are relevant in every country of the globe, such as those based on sex/gender, age, disability, and health conditions imposing access constraints- experience both inside and outside the household? Do they address menstrual hygiene management?**

### Description of the Case Study; main results and lessons learnt Practical approaches to improve participation of everyone

#### *Roles and responsibilities (insights from Uganda)*

During the first week, the group discussed the roles and responsibilities of the national and local governments, NGOs and communities in reducing inequalities in WASH. Participants recognised that NGOs and local governments implementing WASH programmes are aware that specific groups and individuals are marginalised and socially excluded in the areas they work. NGOs and local governments understand that these people need physical and financial support to access WASH services, but they argue that the community are best placed to identify and assist these people.

Examples shared from **Uganda** showed that rural community members and particularly extended family members can be well placed to identify, and support people who are disadvantaged. For instance, the Church of Uganda - TEDDO (CoU-TEDDO) explained that following consultations in a rural village, members of the community and the extended family contributed the household rainwater harvesting jar construction materials for a disabled man who could not afford it himself. These consultations were part of the wider CoU-TEDDO WASH programme aimed at improving the active participation of disabled, older and chronically ill people. CoU-TEDDO found that their approach successfully challenged stigma and discrimination against disabled people. However, it was too reliant on volunteers in the community to support households with a vulnerable person to construct their household WASH facilities. This approach worked well for the first two years, but volunteers are now expecting the households they support to pay them for their services<sup>1</sup>.

Other participants highlighted that relying on family and community members to identify and support people who are vulnerable to exclusion and discrimination could further entrench existing power

<sup>1</sup> A short video of Francis Ediau (CoU-TEDDO) explaining the approach can be viewed here:  
<https://www.youtube.com/watch?v=z4lUwSfUIzQ>

## EQUITY NON-DISCRIMINATION AND INCLUSION (ENDI)

### Human Right to Water

inequalities. People who are socially excluded may be invisible within the household and the community; unwilling to engage after years or a life time of exclusion, so relying on them to ‘speak up’ or on others to prioritise assistance for them carries significant risks.

#### *Affordability and Social Tariffs (insights from Vietnam)*

In **Vietnam** experiences of private rural water enterprises, shared by the Institute for Sustainable Futures<sup>2</sup>, showed how poverty is a barrier to accessing piped water in rural settings. Almost 70% of poor people without a connection said that it was as a result of the connection fee not being affordable.

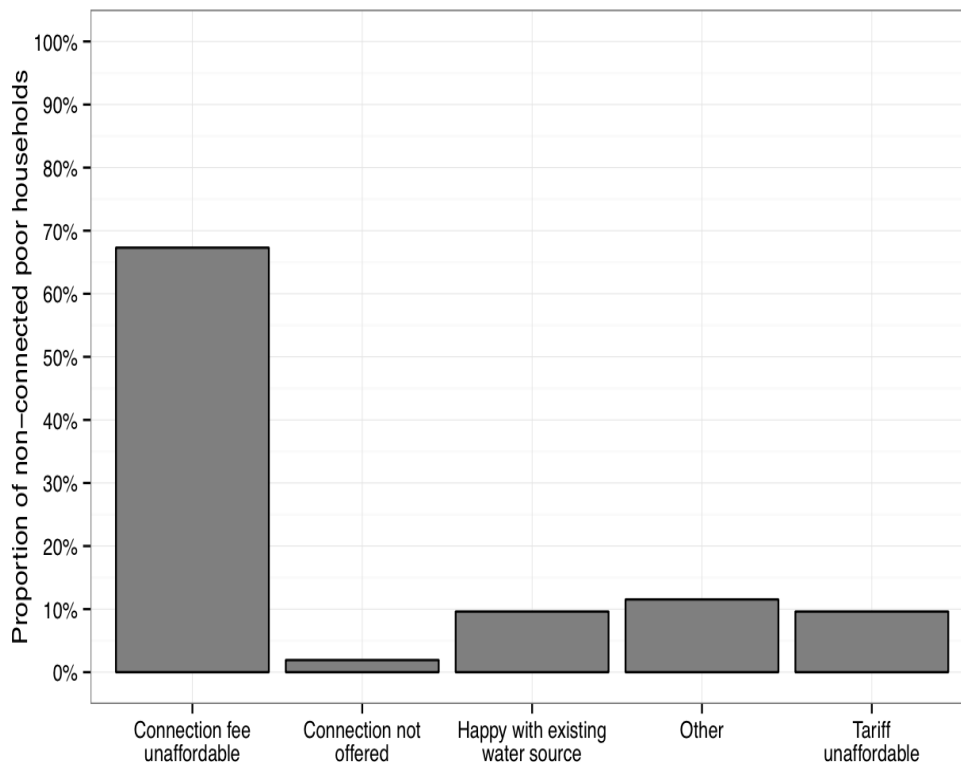

**Figure 1. Reasons for non-connection for poor households (Grant, 2015)**

E-discussants shared that even where legislation and policies on tariff setting exist, these may not contain provisions for a social tariff<sup>3</sup>, or explicitly state how the tariff should be calculated, or who is eligible. Tariff setting should be approached very carefully and with the participation of key stakeholders from outside the community. It should involve the local government, as the state is often responsible for covering the operation and maintenance costs. Ideally the process is transparent; done through existing governance and regulatory structures where they exist and sanctioned by the appropriate authority.

Participants felt that determining user contributions or tariff structures should not only be made on ability or willingness to pay, but also the life-cycle costs of the service. If the life-cycle costs of the service are not incorporated, the service will decrease. This invariably impacts people who are marginalised or excluded first and more severely. One participant shared the ‘At What Cost’ tool, which is currently under development by Water for People (see Box 1).

<sup>2</sup> The Institute for Sustainable Futures is part of the University of Technology, Sydney, Australia

<sup>3</sup> A ‘social tariff’ is support available to certain vulnerable or low income households and designed to help them pay for their services.

## EQUITY NON-DISCRIMINATION AND INCLUSION (ENDI)

### Human Right to Water

#### Box 1 At What Cost?

*At What Cost*, an educational tool for ensuring finance is available to extend services to those unserved and meet the life cycle costs of the existing systems. It was developed and is applied by Water for People. *At What Cost* supports communities to understand the implications of different tariff scenarios, including the introduction of social tariffs. This process is facilitated by representatives from the District or Municipal government and is supported by Water for People staff. The tool and the outputs of the community dialogue link with the District financial model, through a separate set of tools, which is then used for strategic planning and budgeting. Though not prescriptive about how a social tariff is established, this tool provides a promising process that can be replicated.

#### Sector planning (insights from Mali)

WaterAid shared how they engage with authorities during the development of the sectoral plans for more equitable resource allocation in **Mali**. WaterAid developed poverty profiles for the geographic areas they work in and fed these into the government's sector development plans. WaterAid also involved authorities in inclusive WASH implementation activities to raise awareness about the barriers different people face when accessing and using WASH services. Though this process was positive, the use of Sector Development Plans by municipalities and other stakeholders have been very limited. Local authorities have not committed to providing services to the poorest and most marginalised people. Service providers cited the additional cost of accessible and inclusive water and sanitation technologies as the barrier.

#### WASH for more inclusive societies (insights from Uganda and Zambia)

The additional cost of working in inclusive ways and constructing inclusive infrastructure designs is often cited by practitioners, policy and decision makers as a barrier to delivering this at scale. WaterAid's research in **Uganda** and **Zambia** measured the additional time staff took to ensure community mobilization activities were inclusive. They found that most tasks did not need extra staff and that inclusive activities did not take a lot of additional time (Wapling, 2014). With experience the time required may reduce and become the norm. World Vision's findings from a desk review supported this (World Vision, 2014). Their review recommendations include:

1. Identify and engage potential donors to cover the relatively minor additional cost to make all WASH projects inclusive
2. Develop guidelines to ensure that disability inclusion is included in funding proposals
3. Ensure grant acquisition teams are aware and accountable for including allowable cost allocations for disability inclusion from donors

However, discussions on costs perpetuate the perception that inclusion is optional. To realise SDG 6, *Ensure access to water and sanitation for all*, WASH services must have inclusion at its core. Otherwise marginalised groups or individuals will continue to be 'left behind'. There is no two ways about it. The debate must be widened from money or how much time should be spent on making activities inclusive, to seeing that access to water and sanitation for everyone can lead to more inclusive societies, where discrimination and stigmatization are addressed for all aspects of an individual's life.

#### Human rights (insights from Nepal)

The Government of **Nepal** has ratified the International Right to Water and Sanitation and the Convention on the Rights of Persons with Disabilities. They also have gender equality and social inclusion (GESI) policies, strategies and action plans at national level. But these are not implemented by the local government. The webinar presented by the Finnish consulting company, FCG International demonstrated how they implemented the GESI Strategy and the human rights based approach through

## EQUITY NON-DISCRIMINATION AND INCLUSION (ENDI)

### Human Right to Water

action research in rural Nepal<sup>4</sup>. FGG International found that people living with a disability (including the older people) and menstruating women faced the biggest barriers in progressively realising their rights to water and sanitation. Their intervention aimed to address these. Early indications of trends show an improved understanding by community members of the importance of everyone realising the rights to water and sanitation, including menstruating women and disadvantaged castes. Changing deeply held traditional beliefs is a long process but more positive attitudes towards Dalit caste members are emerging.

#### Striving for gender equality

##### Gendered roles in WASH programmes (insights from Chad)

In **Chad**, Concern Worldwide promoted quotas of women on the rural water point management committee and their appointment into key positions. Women’s roles within these committees were generally assigned along existing gender norms: women were committee treasurers<sup>5</sup> and ‘hygiénistes’, which include cleaning duties and men were handpump mechanics. Men were involved in household hygiene and water management, which led to men taking on a greater role in this area and an increased awareness of hygiene practices. Activities carried out by men included providing money for soap and constructing tippy taps. Women continued to be responsible for all the cleaning and hygiene activities in the household. Overall, women’s unpaid labour appeared to have increased through this process.

Traditional gender roles were not challenged as programme staff did not feel it was problematic. Having more women on the WASH management committee was a good first step as their voices were heard for the first time, but Concern Worldwide recognised that it must be seen as a step on a longer journey towards active participation, ownership and control.

##### Exploring the unintended consequences (insights from Mozambique)

Research shared from the University of Denver highlighted how women met at a traditional rural water source in **Mozambique** to collect water, socialize, bathe and get away from conflicts at home (Van Houweling, 2014). They had a high degree of control over this space and could restrict the presence of men. With a communal water point installed and without their meaningful participation in its design and siting, women lost this space and control. Instead of using the protected water point they continued to use the traditional water source as it was more socially valuable to them.

##### Gendered outcomes in WASH programming (insights from Timor Leste)

In **Timor-Leste**, WaterAid carried out participatory research to assess gendered outcomes of a selection of their rural programmes<sup>6</sup> (Kilsby, 2012). Outcomes related to women’s ‘practical gender needs’<sup>7</sup> included greater ease of performing duties and that with water closer to home and men taking a greater share in water-related domestic tasks. Changes in women’s strategic gender interests<sup>8</sup> included increased diversity of roles for women including gaining higher status roles, increased participation in community life, involvement in decision-making, voice and influence. Recognition of women’s rights, improved family relations and greater harmony in the households were also reported.

As a result of this work, WaterAid and the implementing partners integrated practical gender dialogue activities into community mobilisation processes. By applying these tools, the team aimed to implement more gender transformative programmes which aim to address the root causes of gender inequality. Within the household and community the tools:

1. Record how paid and unpaid work is shared between women and men

<sup>4</sup> Webinars are available here: <https://vimeo.com/144622070>

<sup>5</sup> Adhering to the traditional belief that women are more ‘trustworthy’ and ‘detail oriented’.

<sup>6</sup> This was presented on the Inclusive approaches and designs webinar 2. Recordings are in English: <https://vimeo.com/144622070> and French: <https://vimeo.com/144720747>

<sup>7</sup> Practical gender needs are the needs that women identify in their socially accepted roles in society. Practical needs do not challenge the gender division of labour or women’s subordinate position in society.

<sup>8</sup> Strategic interests involve greater decision-making power or control over resources. Addressing strategic gender interests assists women and men to achieve greater equality and to change existing gender roles and stereotypes.

## EQUITY NON-DISCRIMINATION AND INCLUSION (ENDI)

### Human Right to Water

2. Build a greater appreciation of workload and a consideration about how tasks might be shared more fairly
3. Facilitate a discussion about how women and men will be engaged in the WASH programme

#### Box 2 Practical tools for gender transformative programmes

**The 24 hour clock:** Two facilitators lead women and men in separate groups to discuss the different tasks they commonly carry out in one day. The length of time each task takes to complete and when these are done in the day is recorded. Activities include WASH and non-WASH related tasks. The facilitator brings the groups back together and respectfully leads a discussion to explore the differences between daily life and work of women and men and how tasks could be distributed more fairly and equally. This exercise has been adapted from the 24-hour clock activity (Halcrow et al, 2010).

**Who does; who decides** is a card sorting activity in which community members identify different ways that women and men are involved in and affected by WASH issues, workload and decision-making. Participants also think about how WASH responsibilities can be distributed in a fairer, more equitable and effective way. The WASH-related categories cover: daily household WASH tasks; family caring; family decision-making and community decision-making. The participations go through two steps of card sorting by firstly laying out cards for *who* does most of each task and then secondly, *changes* people want to see in relation to who does that task. Finally, participants discuss actions for change together (adapted from Halcrow et al, 2010).

#### Raising awareness (initiatives by DFID, DFAT, WaterAid, UNICEF, SNV, Messiah College, Handicap International in Tanzania, Niger and Mali)

Throughout the e-discussions there was a call for WASH actors to influence donors to prioritise inclusion issues. The tide is turning with the SDGs. In 2014 DFID launched its first Disability Framework (revised and relaunched in 2015) in response to calls from disabled people to be mainstreamed in development (DFID, 2015). The framework includes WASH as a stand-alone work-stream and a call to all its development partners to mainstream disability inclusion. The Department of Foreign Affairs and Trade (DFAT) in Australia, has a strategy for strengthening disability inclusive development in its aid programmes and is seen as a leading donor in disability inclusion (DFAT, 2015).

In **Tanzania**, WaterAid, UNICEF and SNV shared successful experiences of using school WASH initiatives raise awareness of the Government about the need for accessible school WASH services. Their experience led to a commitment to improving school WASH for everyone and the development of a Tanzania’s National School WASH Guidelines (United Republic of Tanzania, 2015)<sup>9</sup>. The organisations are now working with the Government to implement and enforce them.

In Niger and Mali, the Africa WASH & Disability Study shared positive examples of awareness raising and research activities. In **Niger**, in collaboration with the Messiah College they utilised the half-time break of a football match, to host an exposé of the disability inclusive WASH and the various infrastructure modifications and assistive technologies (see photo<sup>10</sup>).

It successfully engaged the audience and raised awareness of disability inclusive WASH. In **Mali** Messiah Collage partnered with Handicap International to conduct a baseline survey on the prevalence rates of disabilities and WASH access. As people with disabilities conducted the survey this challenged the typical view that disabled people are helpless and always dependent on others. It also led to community members with disabilities to speak much more candidly about their WASH situation during interviews. This approach helped to open doors for increased communication and information.

<sup>9</sup> Experiences were presented during the first webinar, which can be watched here: <https://vimeo.com/143141144>

<sup>10</sup> Photo: The Africa WASH & Disability Study & The Collaboratory at Messiah College

## EQUITY NON-DISCRIMINATION AND INCLUSION (ENDI)

### Human Right to Water

#### Inclusive infrastructure designs (insights from Uganda and Niger)

WaterAid **Uganda** shared their experience with the CoU-TEDDO in developing accessible designs in rural settings. Their experience demonstrates that the development of accessible low-cost technologies (through local innovations using local materials) is facilitated by equipping communities, and especially disabled persons in the community with the right information.

Lessons from World Vision and Messiah College in accessible handpump superstructure design indicated that design consistency can be a concern. Care is needed in the development of appropriate technical standards. Examples of ramp design, especially concerning slope and the required, additional cost of materials for construction, should be given adequate consideration. During the course of project implementation in **West Africa**, it became difficult to maintain such standards across several different regions and countries. For example, the costs associated with appropriate ramp access (notably the cost, length and time needed to construct) were notable deterrents. To overcome this, increased artisan and builder interaction with persons with disabilities in the community was needed. Often, some sort of mutually-satisfactory compromise was needed among the “competing” parties involved.

In **Niger** World Vision noted the importance of providing a pedestal at handpump sites to facilitate the lifting of water receptacles (from floor to head) by those with mobility impairments. These should normally be constructed at a height roughly half the distance from floor to head level. Adaptations to protection walls around the handpump were also necessary. Normally, short, thick concrete walls around handpumps not only protect the handpump from roaming livestock, but also can serve the same purpose as a pedestal. However, due to the need to protect the handpump from blowing sand accumulation, walls were narrowed and heightened, and a pedestal replaced the shorter wall to facilitate the lifting of receptacles to the head for those carrying water.

#### Information, Guidance and Support

An Annotated Bibliography was shared which captures resources on reducing inequalities in WASH. It is a live document, so materials can be added continuously<sup>11</sup>. A five-minute film from WaterAid and CoU-TEDDO provided an overview of information, guidance and support for inclusive approaches to WASH in Uganda. Two practical inclusive WASH resources were shared:

1. The [Compendium of Accessible WASH Technologies](http://www.wateraid.org/accessibleWASHtechnologies): A collection of accessible technology design information, which helps communities to see accessibility options made from locally available materials. Available here: [www.wateraid.org/accessibleWASHtechnologies](http://www.wateraid.org/accessibleWASHtechnologies).
2. A Practical Guide for Inclusive WASH at Household and Community levels in Uganda<sup>12</sup>. This resource provides technical design dimensions for contractors to apply in designing accessible infrastructure.



In the video, CoU-TEDDO explained they have standardised accessible infrastructure design across the **Ugandan** ministry of education and

<sup>11</sup> The bibliography is currently on the WaterAid website at <http://www.wateraid.org/policy-practice-and-advocacy/equality-and-non-discrimination/resources>.

<sup>12</sup> Unfortunately only a hard copy of this guide can be found

## EQUITY NON-DISCRIMINATION AND INCLUSION (ENDI)

### Human Right to Water

the ministry of water and environment in partnership with WaterAid and the Appropriate Technology Centre (ATC)<sup>13</sup>. They have also produced guidance for applying these standards and are advocating for inclusive WASH to be taken to scale by others. One challenge highlighted by CoU-TEDDO was the high costs of inclusive designs for public WASH services. Another was the limited simple and clear guidance or manuals for promoting inclusive WASH for water user committee members, government health educators and village heads to use.

WaterAid, WEDC, Leonard Cheshire Disability and the LSHTM shared a selection of data collection tools<sup>14</sup>:

- Nine mixed-method data collection tools focus on WASH access and use, disability, ageing, chronic illness, menstrual hygiene management, safety and security.
- Eight process monitoring tools designed to collect data throughout an inclusive WASH programme to assess progress in capacity of implementing staff, levels of participation of different people at the community level, and the effectiveness of inputs and activities. These tools are designed to be administered by WASH implementers and INGO staff.

IR Worldwide shared the *Minimum Standards for Age and Disability Inclusion in Humanitarian Action* (Age and Disability Consortium, 2015). These are developed by seven agencies working to promote age and disability inclusive humanitarian assistance<sup>15</sup>. They are also relevant for the development sector and include a section on WASH.

### Conclusions and Recommendations

A vast amount of learning was shared between ENDI theme members during the e-discussions and webinars. Drawing on the Equality Checklist (Table 1), this mainly focused on spatial, individual related inequalities and touched on the progressive realisation toward safe and sustainable WASH for all. No substantive discussion was held on group related inequalities such as ethnicity, tribe, race, nationality, language, religion and caste. This demonstrates limited knowledge, understanding and approaches to addressing these in WASH and is something that the ENDI theme should consider developing.

### References

- Age and Disability Consortium as part of the ADCAP programme (2015), *Minimum Standards for age and disability inclusion in humanitarian action*. <http://www.helpage.org/resources/practical-guidelines/emergency-guidelines/>
- Carrard, N., Crawford, J., Halcrow, G., Rowland, C., and Willetts, J. (2014), *A framework for exploring gender equality outcomes for WASH programmes*. <http://connection.ebscohost.com/c/articles/91683153/framework-exploring-gender-equality-outcomes-from-wash-programmes>
- De Albuquerque, C. (2014), *Realising the human rights to water and sanitation: A handbook by the UN Special Rapporteur Catarina de Albuquerque*. United Nations. Available at <http://www.righttowater.info/handbook/>
- DFAT (2015), *Development for All 2015 – 2020, Strategy for strengthening disability-inclusive development in Australia’s aid program*. <http://dfat.gov.au/about-us/publications/Documents/development-for-all-2015-2020.pdf>

<sup>13</sup> The video can be viewed here: [https://www.youtube.com/watch?v=vtLO\\_wym6uE&nohtml5=False](https://www.youtube.com/watch?v=vtLO_wym6uE&nohtml5=False)

<sup>14</sup> These tools and other resources related to ageing, disability, chronic illness and WASH is available at [www.wateraid.org/uk/undoinginequity](http://www.wateraid.org/uk/undoinginequity).

<sup>15</sup> CBM, DisasterReady.org, Handicap International, HelpAge International, IFRC, Oxford Brookes University and RedR UK



## EQUITY NON-DISCRIMINATION AND INCLUSION (ENDI)

### Human Right to Water

- DFID (2015), *Disability Framework – One Year On Leaving No One Behind*.  
[https://www.gov.uk/government/uploads/system/uploads/attachment\\_data/file/487924/DFID-Disability-Framework-2015a.pdf](https://www.gov.uk/government/uploads/system/uploads/attachment_data/file/487924/DFID-Disability-Framework-2015a.pdf)
- Grant, M. (2015), *Increasing or reducing inequalities? Private water enterprises in rural Viet Nam*. Institute for Sustainable Futures, University of Technologies Sydney, Australia. Available at <http://www.rural-water-supply.net/en/resources/details/651>
- Groce, N., Kembhavi, G., Wirz, S., Lang, R., Trani, J-F., Kett, M. (2011), *Poverty and disability – a critical review of literature in low and middle income countries*. University College London and Leonard Cheshire Disability and Inclusive Development Centre. [https://www.ucl.ac.uk/lc-ccr/centrepublishings/workingpapers/WP16\\_Poverty\\_and\\_Disability\\_review.pdf](https://www.ucl.ac.uk/lc-ccr/centrepublishings/workingpapers/WP16_Poverty_and_Disability_review.pdf)
- Halcrow, G, Rowland, C, Willetts, J, Crawford, J, and Carrard, N. (2010), *Resource Guide: Working effectively with women and men in water, sanitation and hygiene programs, IWDA and UTS, Australia*.  
[http://www.inclusivewash.org.au/literature/68164/Working\\_effectively\\_with\\_women\\_and\\_men\\_in\\_water\\_and\\_sanitation\\_programs](http://www.inclusivewash.org.au/literature/68164/Working_effectively_with_women_and_men_in_water_and_sanitation_programs)
- Kilsby, DI. (2014), “Now we feel like respected adults”, Positive change in gender roles in a Timor-Leste WASH programme. November 2012 Australian Council for International Development research in development series, report no. 6. <https://www.iwda.org.au/assets/files/Now-We-Feel-Like-Respected-Adults.pdf>
- Satterthwaite, M., Winkler, I., JMP Working Group on Equality and Non-Discrimination (2012), *JMP Working Group on Equality and Non-Discrimination Final Report*. Available at [http://www.wssinfo.org/fileadmin/user\\_upload/resources/JMP-END-WG-Final-Report-20120821.pdf](http://www.wssinfo.org/fileadmin/user_upload/resources/JMP-END-WG-Final-Report-20120821.pdf)
- United Republic of Tanzania (2015), *Toolkit no. 2: Technical Options for School Water, Sanitation and Hygiene*.  
<https://db.tt/Io8Y8Xjp>
- Van Houweling, E. (2014), Gendered water spaces: a study of the transition from wells to handpumps in Mozambique. <http://www.tandfonline.com/doi/full/10.1080/0966369X.2014.970140>
- Van Houweling, E., Hall, R, P., Sakho Diop, A., Davis, J. and Seiss, M. (2012), *The role of productive water use in women's livelihoods: evidence from Senegal*
- Wapling, L. (2014), Undoing Inequity – water, sanitation and hygiene services that deliver for all in Uganda and Zambia: process review. <http://www.wateraid.org/policy-practice-and-advocacy/equality-and-non-discrimination/resources>
- WaterAid and WEDC (2013), *Inclusive WASH – What does it look like?*  
[http://wedc.lboro.ac.uk/resources/learning/EI\\_Inclusive\\_WASH\\_what\\_it\\_looks\\_like\\_v2.pdf](http://wedc.lboro.ac.uk/resources/learning/EI_Inclusive_WASH_what_it_looks_like_v2.pdf)
- Water and Sanitation Programme (WSP), 1999, *Field note: empowerment through entrepreneurship in water and sanitation*. [http://www-wds.worldbank.org/external/default/WDSContentServer/WDSP/IB/2002/05/03/000094946\\_02042404003742/Rendered/PDF/multi0page.pdf](http://www-wds.worldbank.org/external/default/WDSContentServer/WDSP/IB/2002/05/03/000094946_02042404003742/Rendered/PDF/multi0page.pdf)
- Wapling, L. (2016), *The value of mainstreaming: why disability-inclusive programming is good for development*.  
[http://www.add.org.uk/sites/default/files/ADD\\_The\\_Value\\_of\\_Mainstreaming\\_2016\\_1.pdf](http://www.add.org.uk/sites/default/files/ADD_The_Value_of_Mainstreaming_2016_1.pdf)
- WEDC (2011), Inclusive design of school latrines – how much does it cost and who benefits? Briefing note 1. [http://wedc.lboro.ac.uk/resources/briefnotes/BN001\\_School\\_Latrines.pdf](http://wedc.lboro.ac.uk/resources/briefnotes/BN001_School_Latrines.pdf)
- World Bank (2013), Implementation and completion report on the Socialist Republic of Vietnam for a red river delta rural water supply and sanitation project. [http://www-wds.worldbank.org/external/default/WDSContentServer/WDSP/IB/2013/12/27/000442464\\_20131227104416/Rendered/PDF/ICR27520P0772800disclosed0120240130.pdf](http://www-wds.worldbank.org/external/default/WDSContentServer/WDSP/IB/2013/12/27/000442464_20131227104416/Rendered/PDF/ICR27520P0772800disclosed0120240130.pdf)
- World Bank (2013), *Implementation and completion report to Nepal on a second rural water supply and sanitation project*. <http://documents.worldbank.org/curated/en/2013/02/17410554/nepal-second-rural-water-supply-sanitation-project-rwssp>
- World Vision (2014), Casting the net further: Disability inclusive WASH. <http://www.wvi.org/clean-water-sanitation-and-hygiene-wash/publication/disability-inclusive-wash-report>

## **EQUITY NON-DISCRIMINATION AND INCLUSION (ENDI)**

### **Human Right to Water**

Wilbur, J. and Danquah, L. (2015), Undoing Inequity: water, sanitation and hygiene programmes that deliver for all in Uganda and Zambia – an early indication of trends, briefing paper at 38th WEDC International Conference, Loughborough, UK,

<http://wedc.lboro.ac.uk/resources/conference/38/Wilbur-2191.pdf>

Wilbur, J., Norman, R., & Huggett, C. (2016) *A synthesis of experiences and lessons discussed in the RWSN Equality and Non-discrimination and Inclusion (ENDI) Group 2015*, <http://www.rural-water-supply.net/en/resources/details/771>

## EQUITY NON-DISCRIMINATION AND INCLUSION (ENDI)

### Human Right to Water

#### 3.1.1 Human Right to Water

---

## Driving Change: Piloting a Human Rights: Based WASH project in Bangladesh

---

Type: Short Paper (up to 2,000 words)

**Authors** Shahrukh Mirza, Strategic Support Specialist, WaterAid Bangladesh, Bangladesh, [ShahrukhMirza@wateraid.org](mailto:ShahrukhMirza@wateraid.org), +8801755520184; Ranjan Kumar Ghose, Advocacy Officer, WaterAid Bangladesh; Mahfuj-ur Rahman, Equity and Inclusion Adviser, WaterAid Bangladesh

### Abstract/Summary

WaterAid Bangladesh (WAB) is one of the eight countries piloting a human rights based approach to WASH as part of WaterAid's global HRBA Action Learning Initiative (HRBA-ALI). This paper presents how the project has evolved from a partial concept to an organised, grounded intervention that is shaping the local context in two Union Parishads in northern Bangladesh. In light of the growing importance of the rights perspective in water supply, and as one of WAB's most experimental and innovative projects, this experience holds lessons and questions for organisations looking to understand how to integrate the rights approach in rural water supply projects.

### Introduction

The water, sanitation and hygiene (WASH) sector has been gradually entering a rights-based conversation, triggered and sustained by the declaration in 2010 of water and sanitation as a human right. This has become even more significant in the post-2015 context, where the global shift to the Sustainable Development or Global Goals has brought us into a more dynamic and complex world that goes beyond service delivery.

In WaterAid, the recognition of the importance of rights came with the realisation that the organisation was not sufficiently well-versed in the human rights-based approach (HRBA) to understand the full extent of its impact on programming. An international HRBA Action Learning Initiative (HRBA-ALI) was therefore launched in eight countries in 2013, including Bangladesh. The HRBA pilot is one of the Bangladesh Country Programme's most innovative projects, adopting a learning modality to address changing demands and priorities on the ground. To the best of WAB's knowledge, the HRBA-ALI pilot is the only one in Bangladesh to take an explicitly rights-based approach to rural water supply challenges, and has generated valuable lessons on how this approach can support empowerment, equity and inclusion.

### Description of the Case Study – Approach or technology

WaterAid Bangladesh initiated HRBA-ALI in two Union Parishads (the lowest tier of local government) in northern Bangladesh in June 2013, partnering with a local non-governmental organisation (NGO) SKS Foundation in August 2013. The initial stage of the project was marked by some confusion around how to actualise a rights-based approach. Entrenched ideas about 'typical' WASH projects meant that partner staff and management were still looking to service delivery models to understand the nature of the project. Following internal meetings and workshops, the project was revised to take a system strengthening approach to the challenges of rural water supply, focusing on capacitating key institutions that were identified by the community as being important to rural life, then enabling these institutions and the community to improve water services as part of their reinvigorated activities.

The four key institutions identified on the basis of consultation with the community were the Union Parishad, Digital Centre, School Management Committees and community clinics. These institutions hold

## EQUITY NON-DISCRIMINATION AND INCLUSION (ENDI)

### Human Right to Water

custodianship of the most pressing issues as identified by the community – social safety net allowances, health, education, water and sanitation, equal pay, and transport and communication. The identification of these four points of action took existing activities and reorganised them into distinct, actionable areas of work. A number of encouraging changes have since been observed across the different institutions, discussed below. However, challenges of sustainability and scaling up remain, discussed in the third section.

#### Main results and lessons learnt

##### I Dynamics of change

Since the project began, a multithreaded process has been initiated, whereby wider changes in governance practices across the four institutional bodies, and the community, are showing tangible improvements against the challenges of rural water supply.

##### A. A more accountable Union Parishad

As the lowest tier of local government, Union Parishads comprising of a chairman and twelve members, are the duty-bearers at the heart of any rural community. However, weak decentralisation, fractious politics and a lack of resources and capacities often render them unequal to their considerable responsibilities. A particularly thorny issue in the pilot unions was social safety net allowances, including subsidies for tubewell installations, and how these only went to those favoured by the Union Parishad members or those willing to pay a bribe.

Key in the changes sought by the pilot are for social safety net allowances to be distributed on the basis of a list of poor and hardcore poor, as developed by community groups based on participatory methods, facilitated by project staff. This has become an established practice in both unions now, and subsidies for water connections are now distributed to the poorest households as identified in the list.

Alongside, rights-holders are being made aware of the services entailed to them through various means including the Digital Centre (see below), public citizen's charters, billboards, folk songs and promotional materials. As a result of their awareness of mandated procedures, and simultaneous capacity building of UPs on their responsibilities, both unions have begun to conduct open budget sessions and ward meetings. These platforms provide the space for the community to voice their demands for water and other services, and in recent years, this has led to a perceptible increase in budgeting for water and sanitation.

##### B. Improved information services

Although the Digital Centres with each Union Parishad provide a number of services, including birth and death registration, accessing government forms, public examination results, etc., they are usually under-resourced and under-utilised. As part of the institutional strengthening undertaken by the pilot, a number of promotional activities were undertaken to inform people about the services available at Digital Centres. The Digital Centres in the two unions are now providing updated information, particularly about government social safety net schemes such as allocations for tubewells and other water options, which help community members keep track of how many allowances are being allotted, how many are being distributed, and to whom. This has enhanced the transparency of the safety net scheme, and acts as a further check to practices of corruption and misappropriation in the distribution of government subsidies for water.

##### C. Better school and clinic facilities

A key change within communities has been the growing awareness of the importance of quality services. In schools, reigniting school management committees (SMCs) and parent teacher associations (PTAs) through capacity building workshops, and orientation on water and sanitation, has led to discussions in both forums about providing and maintaining safe water supplies in schools.

## EQUITY NON-DISCRIMINATION AND INCLUSION (ENDI)

### Human Right to Water

Community clinics, which provide grassroots health services, have also become more active regarding safe drinking water through the project's work on its governance mechanisms. The administrative structure of community clinics require there to be two management committees for every clinic. However, the roles and responsibilities of these are poorly understood, and in most cases these committees exist in name only. The project supported reforming and orienting these groups, as a result of which management committees are meeting regularly to discuss issues relating to clinic management, including required improvements to clinic water facilities.

#### **D. A vocal, empowered community**

One of the most significant changes that has come about as a result of the project is in community members themselves, both those who are directly involved in the groups facilitated by the project, and people in the wider community. Since the beginning of the pilot, community members have been oriented on local governance procedures, their entitlements and responsibilities as citizens. Following further training on issues such as water and sanitation, safety net schemes, and advocacy and negotiation, community members have worked together to claim a number of entitlements from the Union Parishad, and played a critical role in the revival of community clinic governance and school management.

Alongside, people in the two unions are acting on their responsibilities as the citizenry. The UP had previously not considered tax collection to be feasible because of resource constraints and the widespread unpopularity of taxation. However, following several promotional activities, including folk songs and billboards, on the importance of tax, Gazaria Union Parishad collected an unprecedented BDT 32,000 as tax from the community for the first time in 2015. The amount collected was spent on reconstructing tubewell platforms for poor and extreme poor families.

#### II. Lessons learned

Since inception, HRBA-ALI has been one of WAB's most dynamic projects, throwing up equal amounts of challenges and achievements. This section draws on the events and outcomes discussed above to elicit lessons on what has worked well, and what may be taken forward to other projects.

#### **A. Focusing on systemic change**

The pilot focused on strengthening systems of accountability within existing institutional bodies, and supporting citizens to become more informed regarding their rights. While there is one consistent approach, the multiple points of entry have created a network of change points within the project area. This includes changes that are directly related to improving water supply, such as increased and fairer distribution of water point subsidies, as well as indirect impact through more informed and capacitated institutions that are working to improve water supply in schools and clinics. The focus on process and procedures as opposed to hardware installation or service targets is central to this multidimensional change, and suggests broadening the scope of water supply projects.

#### **B. Taking a learning approach**

A unique feature of the project is its emphasis on learning by doing, which has led to a series of improvements in project design. This has been the case almost by default, as with no complete precedent, both WAB and the partner had to figure out what HRBA meant in Bangladesh's context. The focus on iterative, experiential learning with space for experimentation is now a strong narrative within international development more generally, with approaches such as [Problem Driven Iterative Approach \(PDIA\)](#) and [Doing Development Differently \(DDD\)](#) gaining ground.

#### **C. The importance of partnerships**

The mindset and capacity of the partner is intrinsic to the success of rights-based projects. It is also important to see HRBA project partnerships as relationships where more support than conventional partnerships may be needed, particularly in nurturing staff capacity and mindset through the adaptive processes and variable outcomes of rights-based activities. This also presents the flip side of the previous point, in that experimentation and revision can take a toll if support systems for staff are not geared to appreciating lessons learned, and instead look to conventional results.

#### **Conclusions and Recommendations**

## EQUITY NON-DISCRIMINATION AND INCLUSION (ENDI)

### Human Right to Water

#### III. Challenges

While significant changes are observed across the four institutions and the communities of the two unions, it is yet too early to understand whether systemic change has been achieved or not. The pilot has showed promise, but there are a number of challenges to achieving impact at scale.

##### A. Sustainability and scaling up

Given that the first phase of piloting is at an end, questions about sustainability are gaining prominence. In terms of the pilot itself, there is a sense amongst both WAB and SKS Foundation that the pilot needs to run for longer in order to embed the changes that have taken place, and provide a level of handholding support at the field level.

Moreover, while the pilot has reached a degree of maturity in planning and implementation, scaling up and replication are yet to be tested. The unique approach of the project, in particular the option to go back to the drawing board frequently, are not generally encouraged or possible within conventional, time and target-bound projects. This also raises questions around resource mobilisation for scaling up, given that the pilot does not fit with the nature of most grant-funded projects. These are some of the very primary issues emerging from discussions at this point, but they are indicative of the much deeper strategic discussions that need to take place around the transition out of a pilot.

##### B. Deeper structural issues

While HRBA-ALI has brought key priorities emerging from the community into its work, there remain structural issues surrounding local power dynamics that are rooted deep in all tiers of government, and relate to the very nature of governance in Bangladesh. Currently, the pilot’s milestones relate mainly to the Union Parishad level, with some reference to extending to the Upazila level. However, the Union Parishad’s actions are often confined by poor decision-making and corruption at upper tiers that they are unable to address, given the highly centralised nature of governance in Bangladesh. The central challenge here, of setting the parameters of a project, is a key question for scaling up the pilot as well as for any other water supply projects looking to bring in HRBA.

#### IV. Conclusion

Bangladesh has been on the HRBA-ALI journey for over two years now. Project experiences gained so far indicate that the systemic focus of the approach has the potential to tackle rural water supply challenges from multiple dimensions, and contribute to wholesale change stemming from improved governance and accountability, rather than hardware-driven progress. However, the real test of the approach lies ahead, as questions of replication and scaling up gain importance.

EQUITY NON-DISCRIMINATION AND INCLUSION (ENDI)

Human Right to Water

---

## Agir pour une meilleure réalisation des droits à l'eau à Tienfala

---

Type: Article court

**Auteurs** Moussa Alou TRAORE, Chargé de Droits, équité et inclusion, WaterAid Mali adresse

Email: [MoussaAlouTraore@WaterAid.org](mailto:MoussaAlouTraore@WaterAid.org)

Numéro de téléphone 223 65 89 15 49/ 76 10 85 72

### Abstract/Résumé

Tienfala est situé à 30 km de la ville de Bamako. Elle est constituée principalement de deux quartiers. Le village compte au total 1 969 habitants, 351 ménages et 111 concessions (Recensement Général de la Population et de l'Habitat (RGPH), 2009). Avant cette initiative, les communautés avaient un accès très limité aux services d'eau, d'hygiène et d'assainissement (EHA). Cela est à cause de l'insuffisance de l'offre, de la mauvaise gestion de l'adduction d'eau sommaire (AES) et de l'absence de mécanisme adapté et fonctionnel. L'approche basée sur les droits humains favorise la concertation entre les communautés et les autorités communales concernant la gestion des services d'eau potable pour améliorer ces défis. En Mars 2015, WaterAid a décidé d'initier ce projet en utilisant l'approche basée sur les droits humains pour améliorer les conditions de vie des populations vulnérables et marginalisées à travers l'amélioration de la demande et de l'offre des services d'eau. Ce projet est en conformité avec l'objectif stratégique de WaterAid qui est la réduction des inégalités. Aujourd'hui, à Tienfala, nous constatons une participation accrue des populations dans la recherche des solutions durables aux problèmes de l'EHA et une réactivité accrue des autorités à la demande des populations.

### Introduction

Tienfala est situé à 30 km de la ville de Bamako. Elle est constituée principalement de deux quartiers. Le village compte au total 1 969 habitants, 351 ménages et 111 concessions (RGPH, 2009).

En matière de fourniture des services d'EHA, le village dispose des infrastructures suivantes:

- Une AES qui alimente sept (07) bornes fontaines publiques et soixante et un (61) branchements privés
- Six (06) pompes à motricité humaines
- Trois (03) puits à grand diamètre
- Deux (02) dépôts de transit

Depuis 2010 WaterAid-Mali, à travers son partenaire Association Malienne pour la Promotion du Développement Rural (AMPDR) intervient dans la commune rurale de Tienfala pour fournir des services d'EHA aux communautés en mettant l'accent sur les personnes pauvres et les plus marginalisées, surtout les personnes aveugles et vivantes avec un autre handicap. Cette intervention a permis de :

- Améliorer la fourniture des services d'EHA en milieu communautaire et scolaire
- Améliorer la gouvernance par les autorités locales en matière de fourniture des services d'EHA
- Renforcer la capacité technique et de gestion des intervenants du secteur d'EHA

Nonobstant ces acquis enregistrés, les conclusions de l'étude sur l'implication des groupes vulnérables dans la mise en œuvre des projets Approvisionnement en Eau Potable, Hygiène et Assainissement (AEPHA) et de l'évaluation sur l'équité et l'inclusion (WaterAid, 2014), ont révélé des insuffisances par rapport à la participation des populations dans la mise en œuvre des projets. Certes, nous notons l'existence des infrastructures EHA mais les communautés ne participent pas à leur gestion, ce qui contribue à la non-durabilité des œuvres.

## EQUITY NON-DISCRIMINATION AND INCLUSION (ENDI)

### Human Right to Water

Ainsi, WaterAid-Mali dans la réalisation de sa mission où chacun a accès à l'eau potable, l'hygiène et l'assainissement et conformément à son objectif stratégique de la réduction des inégalités a initié le projet “**Agir pour une meilleure réalisation des droits à l'eau**”. Ce projet a contribué à l'amélioration des conditions de vie des populations de Tienfala à travers l'amélioration de l'offre des services et la gouvernance en matière de fourniture des services d'eau. Les actions d'autonomisation des groupements de femmes, de jeunes et des personnes en situation de handicap (PSH) ont stimulé la participation des différentes catégories sociales dans la gestion des questions d'eau et d'assainissement.

#### Description de l'étude de cas – Approche ou technologie

La stratégie générale de WaterAid est basée sur la conviction profonde que « l'accès à l'eau potable et à l'assainissement sont essentiels à la vie, chacun ayant droit à ces services de base »

Dans sa stratégie 2015 – 2020, WaterAid travaillera à atteindre l'égalité en termes d'accès à l'EHA et, plus largement, dans la société en comprenant et en résorbant les inégalités de pouvoir, afin de réaliser son objectif d'accès « **partout et pour tous** ».

Pour faciliter la transition vers cette nouvelle stratégie, avec laquelle nous ne parlerons plus de besoins satisfaits mais de droits réalisés, le programme pays a planifié de réaliser un projet pilote d'approche basée sur les droits humains à Tienfala.

L'objectif de cette initiative était de contribuer à l'amélioration des conditions d'accès des femmes, des jeunes, des PSH (qui n'ont pas les ressources nécessaires pour faire face aux charges récurrentes de la famille, surtout celles liées à l'eau), à travers une participation plus accrue des populations aux processus de prise de décision concernant la gestion des questions EHA.

Pour atteindre cet objectif, un diagnostic préalable a été réalisé dans la zone d'intervention du projet, pour comprendre le contexte local, les relations de pouvoir, les barrières d'accès à l'eau et identifier les acteurs à mobiliser autour du projet et déterminer les stratégies de mise en œuvre. Ce diagnostic a révélé :

- L'inadaptation des points d'eau et des technologies utilisées pour la construction des ouvrages d'eau (système d'exhaure inadapté)
- La méconnaissance des droits à l'eau et à l'assainissement par les communautés
- La faible participation des populations au processus décisionnel concernant la gestion des questions d'eau
- La perception de discrimination parmi les communautés et les autorités à l'égard des PSH et des femmes (L'inégalité d'accès à l'EHA à la terre et d'autres droits connexes).

Une équipe composée de WaterAid, l'ONG 'Association Malienne Pour le Développement Rural', la Mairie et les Organisation de la Société Civile a été mise en place pour assurer la coordination et le suivi des activités sur le terrain.

Les actions ci-après ont été entreprises : **1)** La formation des autorités locales et les organisations de la société civile sur les droits à l'eau et l'assainissement et la redevabilité sociale **2)** La mise en œuvre de la fiche d'évaluation communautaire ; **3)** Les rencontres d'échanges entre les autorités locales et les populations ; **4)** L'organisation d'espaces d'interpellation démocratique ; **5)** L'appui matériel et financier aux groupements de femmes, de jeunes et de PSH ; **6)** La formation en gestion financière et la mise en œuvre des activités génératrice de revenus ; **7)** La célébration de la journée mondiale des droits de l'homme (le droit à l'eau et l'assainissement était adopté en 2010. Maintenant, le droit est séparé entre le droit à l'eau et le droit à l'assainissement).

La mise en œuvre de ces différentes activités a contribué à l'atteinte des objectifs du projet.

#### Résultats principaux et leçons tirées

*Les résultats majeurs ci- après ont été atteints:*



## EQUITY NON-DISCRIMINATION AND INCLUSION (ENDI)

### Human Right to Water

- Une prise de conscience collective des populations (y compris les autorités locales) sur les questions d'eau, les personnes exclues des services d'eau et les raisons de leur exclusion. Elle a permis la participation des populations (toutes les catégories sociales) dans la recherche des solutions durables aux problèmes et une compréhension plus approfondie de la part des personnes exclues et les raisons de ces exclusions. L'engagement des femmes a contribué à la prise en charge des coûts de réparation et d'entretien des points d'eau dans les écoles, soutenu par la signature d'un protocole d'entente entre la Mairie et les groupements de femmes, est une preuve tangible de cette prise de conscience.
- Les communautés sont capables de faire entendre leur voix par les détenteurs de pouvoir (y compris les autorités locales et les prestataires de services d'eau). Lors des cadres de concertation et espaces d'interpellation démocratiques, les populations qui n'ont jamais eu le courage de dénoncer les injustices dont ils souffrent, ont interpellé les autorités par rapport à la violation des droits à l'eau et d'autres droits connexes (accès à la terre, l'éducation des filles, etc.). Les réunions de concertation continuent dans les communautés même après la fin du projet.
- L'amélioration de la gouvernance en faveur des groupes exclus par rapport à l'accès à l'eau. Le projet est arrivé à transformer le système de gouvernance, en renforçant la capacité des populations à revendiquer leurs droits et à demander des comptes aux autorités responsables et les autorités à avoir la volonté d'être redevables et transparent. Cela se manifeste par la prise en compte de la situation économique des populations dans la fixation des tarifs d'eau suite à de nombreuses réclamations faites par les communautés pour réduire le tarif d'eau. Cet aspect est en lien avec les droits humains car il permet de rendre financièrement accessibles les services EHA aux plus pauvres (la Mairie a pris la décision de vendre le m<sup>3</sup> d'eau à 300Fcf qui est beaucoup plus abordable pour les plus pauvres. De plus des séances de restitution publique ont été organisées par les autorités pour rendre compte de la gestion des AES du village).

### Les leçons suivantes ont été tirées ;

- L'importance d'avoir des citoyens bien informés : la participation des populations repose sur la connaissance des droits à l'eau et à l'assainissement. Un public bien informé peut appuyer les politiques et les programmes d'AEPHA. Ils peuvent également contribuer à la réalisation progressive des droits à l'eau et l'assainissement à travers le respect des principes de non-discrimination et d'égalité, l'information, la participation et l'obligation de rendre compte.
- L'autonomisation des groupes vulnérables : l'autonomisation des groupes vulnérables à la base par l'organisation et l'appui à la mise en œuvre des activités génératrices de revenus collectives est un élément distinctif de l'approche en matière de fourniture des services d'EHA. Elle favorise la participation et le leadership. Elle est aussi un levier pour l'équilibre des relations de pouvoir.
- Faire en sorte que les inégalités sociales n'empêchent pas la participation de tous représente donc un réel défi. Pour relever ce défi, le projet a utilisé les outils de démocratie participative (fiche d'évaluation communautaire, Open Space<sup>16</sup> et les Espaces d'Interpellation Démocratique<sup>17</sup>). Cela a permis d'instaurer une relation de confiance entre les autorités et les populations et entre les populations elles-mêmes.

### Conclusions et Recommandations

Cette initiative pilote basée sur les droits humains a contribué à améliorer les conditions d'accès des groupes vulnérables à l'eau et l'assainissement dans le village de Tienfala. Elle a aussi contribué à une plus

<sup>16</sup> 'Open Space ou 'Forum Ouvert' en français, réunit des catégories sociales dans une communauté, pour faire appeler à toutes les groupes et leaders pour discuter des problèmes communautaires et de proposer des solutions concrètes pour les résoudre. A la fin, un plan d'action et des recommandations sont écrit.

<sup>17</sup> 'Espaces d'Interpellation Démocratique' permettent à une communauté d'interpeller les autorités communales sur les sujets de l'eau et l'assainissement pour les rappeler de leurs responsabilités de faire respecter les droits à l'eau et à l'assainissement et de résoudre les problèmes communautaires

## EQUITY NON-DISCRIMINATION AND INCLUSION (ENDI)

### Human Right to Water

grande redevabilité des entités responsables envers les groupes exclus à travers l'institutionnalisation par les autorités de la restitution publique sur la gestion des questions d'eau qui a mené à l'amélioration de la gestion des ouvrages EHA plus précisément l'AES du village.

L'approche basée sur les droits humains favorise l'autonomisation des femmes, des jeunes et des PSH et constitue un levier pour promouvoir la participation des populations dans la recherche des solutions durables aux problèmes d'EHA. La réussite d'une telle initiative dépend du niveau d'autonomisation des groupes de femmes, de jeunes et de PSH et nécessite un engagement de long terme des communautés. La durée d'une telle initiative dépend sur le diagnostic et la situation de chaque communauté.

Le processus de changement de pouvoir entraîne souvent des tensions entre autorités et populations. Pour atténuer ces tensions, le projet a renforcé la capacité des autorités et des populations afin d'équilibrer le jeu et d'instaurer une relation de confiance. Cela se manifeste par l'existence du dialogue permanent entre les autorités et les communautés (les outils tels que les espaces d'interpellation démocratique, les restitutions publiques et les cadres de concertation ont été institutionnalisés dans les plans d'action des autorités et des communautés).

Nous recommandons aux acteurs du secteur l'adoption d'une approche basée sur les droits humains pour la mise en œuvre des projets EHA en tant que gage de durabilité des ouvrages. L'approche, qui met l'accent sur la participation des communautés (de connaître leurs droits à l'eau et l'assainissement et de demander aux autorités l'amélioration des services EHA, et de jouer un rôle dans la gestion des questions d'eau) et le rôle important des autorités (locales et nationales) dans la provision d'EHA, sont tous essentiels pour assurer que notre travail est durable et pour atteindre notre objectif d'accès de « partout et pour tous 2030».

#### Références

[De Albuquerque, C. \(2014\). 'Realising the human rights to water and sanitation: A handbook'. For more details see <http://www.ohchr.org/EN/Issues/WaterAndSanitation/SRWater/Pages/Handbook.aspx>](http://www.ohchr.org/EN/Issues/WaterAndSanitation/SRWater/Pages/Handbook.aspx)

[Recensement Général de la Population et de l'Habitat \(RGPH\). \(2009\). For more details see <http://www.instat-mali.org/>](http://www.instat-mali.org/)

[Wapling, L. \(2014\). Rapport de la revue de l'équité et inclusion au WaterAid Mali 2014](#)

[WaterAid. \(2014\). Rapport de l'étude sur la participation des groupes vulnérables dans la mise en œuvre des projets EHA 2014](#)

## EQUITY NON-DISCRIMINATION AND INCLUSION (ENDI)

### Human Right to Water

---

# Achieving systemic change in WASH through the Human Rights Based Approach

---

Type: Short Paper

**Authors** *Apollos Nwafor, Regional Advocacy manager, WaterAid (West Africa) [apollosnwafor@wateraid.org](mailto:apollosnwafor@wateraid.org)  
Landry Ouangre, Policy Officer, WaterAid Burkina-Faso, [landryouangre@wateraid.org](mailto:landryouangre@wateraid.org)*

### Abstract/Summary

The Human-Rights-Based Approach (HRBA) aims to ensure access of the poor and marginalised to safe water, hygiene and sanitation in a sustainable manner. When implemented, this approach will raise community awareness to claim their rights and increase accountability and responsiveness of authorities to meet demands. Integrated into a 2 year pilot programme in West Africa that started in Burkina Faso in 2014, the approach has already reaped a number of successes including the integration of the right to WASH in the national constitution, a key recommendation made during the national water forum. Locally, the HRBA has empowered authorities and staff of relevant partner organizations in Burkina Faso and Ghana to raise communities’ awareness of their right to WASH as well as to strengthen the commitment of both the right holders and duty bearers through influencing policy processes. WaterAid will keep its advocacy efforts on the right to access and scaling up of the HRBA. This paper draws on the experience of implementing the HRBA in Burkina Faso, documenting both the challenge and opportunity that the political uprising presented for its implementation. The paper concludes by highlighting the successes and the lessons learnt, important not only for the WASH sector, but for wider rights-based interventions.

### Introduction

WaterAid’s work is driven by a firm belief that access to safe water, sanitation and hygiene is vital for health, education and livelihoods, and forms the first essential step in overcoming poverty - the people who are most deprived of their basic WASH needs are typically the poor and the marginalised (Unicef and WHO, 2011). While access to safe water and sanitation are now recognised as universal human rights, its fulfilment in practice remains a crucial challenge for the West African region post-2015. The current Sustainable Development Goals present an opportunity to address the growing inequalities in access and challenges of sustainability in the region and in Burkina Faso more specifically.

The HRBA underlines the multidimensional nature of poverty, describing poverty in terms of a range of interrelated and mutually reinforcing deprivations, drawing attention to the stigma, discrimination, insecurity and social exclusion associated with poverty (OHCHR, 2002). The principles of the human right to water and sanitation include non-discrimination and equality, access to information and transparency, participation, accountability and sustainability (Right to Water, 2003). The HRBA is a way of applying these principles to support people in accessing WASH services and in turn to help them walk away from poverty.

WaterAid has been gradually building its knowledge and capacity on the application of the HRBA to help achieve universal access (Gosling, 2014). The approach has already been piloted in Burkina Faso as part of a wider action learning initiative involving 8 WaterAid countries in Africa and South Asia. Under this learning initiative, the essential feature of the HRBA of working with numerous actors was highlighted. Key stakeholders included: (a) ‘rights holders’, especially the most marginalised and vulnerable individuals and groups; (b) ‘duty bearers’ at all levels of government; (c) partner agencies who delivered project activities and (d) WaterAid staff. Other essential features were (1) identification of the poor, (2)

## EQUITY NON-DISCRIMINATION AND INCLUSION (ENDI)

### Human Right to Water

recognition of the relevant normative national and international human rights frameworks, (3) equality and non-discrimination, (4) participation and empowerment, (5) progressive realisation of human rights, and (6) monitoring and accountability (Hunt et.al., 2004) which is consistent with the need to increase social accountability and widely endorsed by development actors like the World Bank (World Bank Social Accountability Sourcebook, 2004).

Having already carried out an analysis of power, rights, risks and barriers to WASH access during the pilot initiative, WaterAid Burkina Faso (WABF) staff were well positioned to capitalise on the opportunity that the political crisis presented in 2014 to further implement the HRBA to improve WASH access.

#### **Context, aims and activities undertaken**

In October 2014, Burkina Faso experienced a popular uprising that led to regime change and a new political leadership. This political situation led to the dissolution of Parliament, replaced by a National Transitional Council (CNT); Special Delegations (DS) also replaced the Municipal Councils. These new unelected officials were arguably not accountable to the people and were not in a position to serve their needs: their primary responsibility was the implementation of a government-designed programme that in all senses was not based on the HRBA principles. The uprising also saw the emergence of a strong civil society movement (including youth and womens groups) that kept an eye on the country’s governance and increased political pressure to positively influence change.

The human rights to water and sanitation guarantee the obligation of the state as the ‘duty bearer’ to protect, respect and fulfil the rights of and empower the ‘right holders’, which are the people to demand and claim these rights as well as take responsibility for maintaining their services (Right to Water, 2003). In order to be effective, the rights must be adopted into and upheld in national laws and policies. Although challenging to implement, (of all the countries in Africa, only South Africa, Kenya, Niger, Tunisia and Zambia have incorporated the rights to water and sanitation into their constitution), the combination of new leadership and increased public pressure in Burkina Faso gave WaterAid the opportunity to push for the necessary changes to the constitution, supporting legal frameworks and institutional reforms to improve access to water and sanitation services.

Capitalising on the increased civil society engagement of the uprising, WABF undertook a series of activities to strengthen the capacity of civil society organisations (CSO) and community groups including those representing the poorest and most marginalised to increase their ability to advocate for the enshrining of the rights to water and sanitation, as well as other rights, into laws and policies. WABF also provided support in the development of financing strategies and frameworks, engaging with existing social movements and local and central government authorities. We also helped to strengthen service delivery with HRBA principles to draw evidence for policy influencing and systemic change.

Applying the principles of accountability, participation and access to information, at the local level, citizens and civil society groups engaged with the local government on expenditure for water using accountability platforms to track commitments, participated in local level planning and ensured that services were maintained through repairs and community management mechanisms. At the national level, there were campaigns and meetings held with key officials of the national transitional council and position papers and proposals were developed on how to realise water and sanitation as human rights.

Following this capacity building, partners felt empowered and better able to engage with local authorities about securing their rights and demanding accountability through meetings and monitoring the quality of services and facilities. At the national level, the CSO network, with support from WABF, held a forum with policy makers and other stakeholders on the rights to water and sanitation as constitutional rights. There were also engagements with the parliament to improve its understanding of the rights to water and sanitation.

The fragile political situation in Burkina Faso brought significant challenges to WASH governance at the local and national level but also presented an opportunity for engagement. The challenges included the

## EQUITY NON-DISCRIMINATION AND INCLUSION (ENDI)

### Human Right to Water

inability of the local authorities to acknowledge and understand the human rights principles – they claimed that being unelected, they had no mandate to deliver services and had been appointed by the state to solely administer the local government. This challenge was overcome by building upon the existing demands of citizens for political change, and working closely with CSOs, whose understanding of the HRBA and capacity in its delivery had been strengthened by WaterAid’s sharing of knowledge and experience of working on rights (Gosling, 2014). The Capability, Accountability and Responsiveness (CAR) framework (Moore and Teskey, 2006), which WaterAid had used as its underlying theory in promoting responsible governance in the WASH sector through a previous 5 year project promoting governance and transparency (Diouf, P., 2013) also proved invaluable in influencing change.

### Main results and lessons learnt

In Burkina Faso, the major achievements of this approach can be captured as follows: a) recognition of the rights to water and sanitation in the constitution; b) increased knowledge and empowerment of communities at local level; (c) Empowerment of duty bearers - local, administrative and political authorities.

#### a) Recognition of the Human Rights to Water and Sanitation in the constitution

While WaterAid’s pilot project had laid the groundwork for the adoption of the human rights to water and sanitation into the constitution, the political uprising triggered an acceleration in the process. The need to revise the constitution provided WaterAid and other sector players the opportunity to push for its integration much earlier than anticipated; the Human Rights to Water and Sanitation have now been in effect since November 2015. Indeed, Article 18 of the constitution reads that “education, **safe water and sanitation**, training, social security, housing, energy, sport, leisure, health, mother and child protection, assistance to the elderly, to people with a handicap, artistic and scientific creation are social and cultural rights recognized by the constitution and will be promoted”.

#### b) Increased knowledge and empowerment of communities at local level

This achievement was observed in Dissin local government where the pilot project delivered a number of activities including: awareness-raising, capacity-building and dialogue with local authorities. Communities now understand that they have rights and can bring duty bearers to account and ensure that these rights are fulfilled. The community dialogues are now integrated as part of community activities with continued support from WABF’s local partner and the community leaders.

The ability of a local women’s group to access land is another example of how the HRBA can empower communities to demand their rights and contribute towards ‘poverty reduction’ and positive social change. WABF worked with the women’s group to build their awareness of the right to water and sanitation which led them to develop initiatives targeting local authorities to address other issues important to them. Indeed, their lobbying, advocacy and engagement efforts have proven fruitful through the recognition of their rights especially their access to land.

WABF experience has shown that people who can claim their rights and who are actively engaged in decision making are those able to take independent initiatives and assume responsibility. This is where the empowerment of women and people living with disabilities remains critical because they are the ones who suffer most from lack of access to safe water, with the former group often bearing the burden of collecting water for their households. Our experience here reveals that empowerment is a long-term and iterative process due to the deep cultural structures which perpetuate inequalities and disempower women and girls. For instance, women are treated as second-class citizens and are often unable to speak out for themselves or participate actively in decision-making processes.

#### c) Empowerment of the duty bearers – local, administrative and political authorities

Duty bearers have been made aware of and acknowledge the approach and the importance of respecting and implementing human rights. The duty bearers were identified through a participatory process using

## EQUITY NON-DISCRIMINATION AND INCLUSION (ENDI)

### Human Right to Water

the power relation tool and carried out by social groups including women, children, and people with disabilities. This process improved the understanding of why as the state and service provider they need to support the proposed constitutional reform of including the rights to water and sanitation. Empowered duty bearers also became allies in the constitutional debate and convinced other colleagues in government for the need to include water and sanitation as rights.

### Conclusions and Recommendations

- **HRBA should be applied from the inception stage of programmes:** It is important to include HRBA analysis and tools from the planning stage and not as an after-thought in projects or programmes. It strengthens the analysis and contributes to local ownership and sustainability of the programmes and their wider results. This is based on the fact that this learning initiative was introduced into an ongoing intervention rather than from the inception of engagement with the community. Although ultimately successful, the shift from a ‘needs-based’ approach to a HRBA did prove challenging.
- **Application of HRBA is context specific:** While the principles of human rights are universal the application of the HRBA differs according to the particular blockages it is trying to address. Its results may not be fully anticipated as there are usually emerging issues in the process. Related to this is the fact that while some stakeholders have included HRBA in their strategies, they do not have a clear understanding of how this works and which tools are suitable for the context (O’Meally, 2013). It is important to consider the culture, policy environment and the prevailing politics of the time to ensure the application of the HRBA is appropriate – the latter being particularly central in this example.
- **People are the most important factor:** While the current interest in HRBA is ascribed to the fact that financial and technical partners now make it a requirement before providing funding and support, it is important to focus on the people involved in achieving expected results rather than the funding opportunities that the HRBA presents. People (both ‘rights holders’ and ‘duty bearers’) were central to pushing for the inclusion of WASH rights in the constitution, building from the ground where the community members were able to demand for accountability from the local authorities eventhough they were unelected and were operating under what can be termed an emergency situation where the constitution and rule of law was basically suspended.
- **Tools and approaches must be appropriate:** The fact that a tool is effective in one context does not necessarily mean it is appropriate for another, such was the experience in Burkina Faso. For instance, the political uprising meant that a process mapping tool was not appropriate for the context. There is also the need to ensure that there are clear policies and strategies for targeting the poorest and excluded. These institutional frameworks are the basis for engagement and strengthens the ability of right holders to hold duty bearers to account. This should be supported by clear indicators for measuring success as part of monitoring and reviews. One key example of this is the government strategy for targeting the poor by the Ministry of Social Welfare in Burkina Faso which did not have measurable indicators.
- **Community empowerment as a sustainability enabler:** The social change expected under the HRBA requires that communities are empowered. Indeed, the assumption is that the more they are empowered, the better they can link the work carried out to the impact on their lives, helping to foster the sustainability of interventions. Participation is also a key factor for influencing change, influencing the adoption of the Human Rights to water and sanitation in the constitution and ensuring that benefits are equitably shared among communities. As communities were able to demand accountability and claim their rights to WASH services increased pressure was placed on the government as duty bearer to maintain services in collaboration with WASH committees. The improved collection of community contributions, as part of their responsibility to maintain services, further bolsters the sustainability of WASH services.
- **A multi-stakeholder approach is needed to implement HRBA:** As stated earlier, HRBA involves several key stakeholders including but not limited to, NGOs and associations; Local Governments; Human Rights Commission; the media (in particular community radio); the Ministry of

## EQUITY NON-DISCRIMINATION AND INCLUSION (ENDI)

### Human Right to Water

Sanitation, of Justice and Human Rights; parliament; and financial and technical partners such as donors and organisations with expertise. The experience on the ground had different stakeholders at each level or point in time playing a role. For instance, at the local level, the community groups and the local CSOs were pivotal in establishing the accountability platform whose use served as evidence of national level engagement and contributed to improved services at the local level. The civil society network at the national level, the parliament and others also played strategic roles in strengthening the platform.

- **Building interest at the strategic and political level can be strengthened by use of evidence from the ground:** The engagement with parliamentarians, ministries and agencies at the national level was strengthened with community and local partner representatives providing personal testimonies with documented evidence provided by WABF in building pressure and drawing attention to the impact of unsafe water and improved sanitation through a Human Rights lens.

Following this achievement, and increased interest from donors, including DANIDA and the UN Democracy Fund, there are now plans to scale-up the approach. There is now a parliamentary network on WASH which is supporting the financing of WASH as a way of fulfilling the right to water and sanitation, and ensuring that policies and institutional reforms are supportive of the rights to water and sanitation. The President has subsequently established the Ministry of Water and Sanitation, a decision taken, in part, following WaterAid's intervention, policy brief, and advocacy meeting. The Ministry of Justice and the Human Rights Commission in Burkina Faso are now working with WABF to fulfil and protect this constitutional right. WaterAid will continue to facilitate and capitalise on civil society engagement and support government capacity to engage citizens in fulfilling this right among other rights.

### References

- Diouf, P. (2013). 'Governance and Transparency Fund Programme Project Completion Report'. For more details see [file:///wafs/users\\$/HannahC/AppSense%20Settings/Downloads/Governance%20and%20Transparency%20Fund%20programme%20poject%20completion%20report%20\(1\).pdf](file:///wafs/users$/HannahC/AppSense%20Settings/Downloads/Governance%20and%20Transparency%20Fund%20programme%20poject%20completion%20report%20(1).pdf)
- Gosling, L. (2014). 'Moving along the right track? The experience of developing a rights-based approach at WaterAid'. *Waterlines*, 4(3), 357-374. For more details see <http://www.developmentbookshelf.com/doi/abs/10.3362/1756-3488.2014.035>
- Moore, M. and Teskey, G. (2006). 'The CAR Framework: Capability, Accountability, Responsiveness. What Do These Terms Mean, Individually and Collectively? A Discussion Note for DFID Governance and Conflict Advisers'. For more details see <http://www2.ids.ac.uk/gdr/cfs/pdfs/CARframeworkDRCweb.pdf>
- OHCHR. (2002). 'Principles And Guidelines For A Human Rights Approach To Poverty Reduction Strategies'. For more details see <http://www.ohchr.org/Documents/Publications/PovertyStrategiesen.pdf>
- O'Meally, S. C. (2013). 'The World Bank - Mapping Context for Social Accountability: A Resource Paper'. For more details see [http://siteresources.worldbank.org/EXTSOCIALDEVELOPMENT/Resources/244362-1193949504055/Context\\_and\\_SAcc\\_RESOURCE\\_PAPER.pdf](http://siteresources.worldbank.org/EXTSOCIALDEVELOPMENT/Resources/244362-1193949504055/Context_and_SAcc_RESOURCE_PAPER.pdf)
- Right to Water. (2003) 'Content of the Rights and Principles'. For more details see <http://www.righttowater.info/why-the-right-to-water-and-sanitation/the-right-to-water-a-legal-obligation/the-content-of-the-rights-explained/>
- Right to Water. (2003). 'Realising the human rights to water and sanitation: A handbook'. For more details see <http://www.righttowater.info/why-the-right-to-water-and-sanitation/the-right-to-water-a-legal-obligation/the-content-of-the-rights-explained/>
- Unicef and WHO. (2011). 'Drinking Water Equity, Safety and Sustainability', JMP Thematic Report on Drinking Water. For more details see [http://www.wssinfo.org/fileadmin/user\\_upload/resources/report\\_wash\\_low.pdf](http://www.wssinfo.org/fileadmin/user_upload/resources/report_wash_low.pdf)

**EQUITY NON-DISCRIMINATION AND INCLUSION (ENDI)**

**Human Right to Water**

World Bank Social Accountability Sourcebook. (2004). 'Tools and Methods'. For more details see  
[http://www.worldbank.org/socialaccountability\\_sourcebook/Tools/toolsindex.html](http://www.worldbank.org/socialaccountability_sourcebook/Tools/toolsindex.html)



## EQUITY NON-DISCRIMINATION AND INCLUSION (ENDI)

### Universal Access & the Hard to Reach

#### 3.1.2 Universal Access & the Hard to Reach

---

# Achieving universal and equitable access to water, sanitation and hygiene (WASH) for all – practitioner perspectives and perceptions

---

Type: Long paper

Authors: Lead author: Tracey Keatman, Senior Consultant, Partnerships in Practice, UK

[tracey@partnershipspractice.co.uk](mailto:tracey@partnershipspractice.co.uk) Tel: +44 (0)7944 515982

Authors: Louisa Gosling, Naomi Carrard, Hannah Neumeyer, Janina Murta, Virginia Roaf, Al-hassan Adam

#### Abstract/Summary

Every individual holds the human rights to water and sanitation; these rights safeguard access to water for personal and domestic uses and to sanitation at home, at work and in other public places. However, many countries still struggle with realising the rights in practice, and with interpreting what they mean for government. Local government has a pivotal role in making services available to all, but human rights can seem very abstract and may have little meaning for their specific roles and responsibilities. Therefore a consortium of WASH sector partners undertook a project to talk to local government representatives and others to hear their perceptions on how to practically use the human rights framework to make the ‘universal access’ mandate of SDG 6 a reality. The paper provides an overview of the findings that will be useful for sector practitioners to consider when supporting the application of the human rights framework.

#### Introduction

Water and sanitation are human rights – yet these rights are not fully realised for everyone, everywhere and many questions still remain on how these rights can be used in practice. This paper draws together the key findings from a research project exploring local government perceptions on how to practically use the human rights to water and sanitation to help meet the challenges in achieving universal access to water<sup>18</sup>, as expressed in Sustainable Development Goal (SDG) 6.

Lessons learned from this project are feeding into the development of concise, practical and easy-to-implement materials that local government officials around the world can use when planning, designing and / or delivering water and sanitation services for all.

#### Context, aims and activities undertaken

Every individual, regardless of gender, race, ethnicity, where they live or other form of discrimination, holds the human rights to water and sanitation; these rights safeguard access to water for personal and domestic uses and to sanitation at home, at work and in other public places. All countries recognise that access to adequate water and sanitation services are human rights that must be progressively realised for everyone. However, many countries still struggle with realising the rights in practice, and with interpreting what these human rights mean for government. Similarly, the SDG 6 focus on universal access implies that *all* people must be able to access water and sanitation without discrimination, and target 6.2 also requires governments to “*pay particular attention to women and girls and those in vulnerable situations*”.<sup>19</sup>

At the national level, the government and all its institutions are duty bearers of human rights and it is their

---

<sup>18</sup> The project focused on the rights to water and sanitation although many respondents spoke more about water supply rather than sanitation services.

<sup>19</sup> UN Resolution A/Res/70/1 (2015) Transforming our world: the 2030 Agenda for Sustainable Development, Goal 6.

## EQUITY NON-DISCRIMINATION AND INCLUSION (ENDI)

### Universal Access & the Hard to Reach

responsibility to work towards realising adequate water and sanitation services for everyone and to thereby fully realise the human rights to water and sanitation for all. This includes water operators, when they are run by the State. Where water operators are private institutions (including private water companies as well as smaller scale providers – both formal and informal), the government has the responsibility to ensure that they do not violate human rights, and also transfers particular responsibilities on to service providers for realising the rights:

*States’ obligations to realise the human rights to water and sanitation apply equally to informal as to formal service providers. States are therefore required to ensure that these operators at the least do not interfere with the enjoyment of the human rights to water and to sanitation, and in the best cases that they contribute to the realization of the rights. This is particularly relevant in the context of informal settlements, where residents tend to be disadvantaged and living in poverty, and are most in need of State support and protection. To date, far less attention has been paid to the regulation of informal, small-scale providers than to the regulation of utilities and large private companies. (de Albuquerque, 2014, p.49<sup>20</sup>)*

Local government specifically has a pivotal role in making services available to all, but human rights can seem very abstract and may have little meaning in relation to their specific roles and day-to-day responsibilities. Hence, in 2014, the former UN Special Rapporteur on the human rights to water and sanitation, Catarina de Albuquerque, published a Handbook<sup>21</sup> with comprehensive guidance on the practical implications of the realisation of these rights. The Handbook applies the rights to the different actions that commonly guide programming in the WASH sector. In particular:

- Water and sanitation services for all will only be achievable if countries systematically identify and address existing inequalities;
- Sustainable maintenance of services over time has to be achieved to ensure services for all;
- Services will need to meet criteria of quality/safety, affordability, accessibility, availability and acceptability to fulfil the human rights framework and the aims of the SDGs.

Although the Handbook provides very practical guidance, information about the human rights to water and sanitation still needs to become more accessible to local government duty bearers. Therefore, the aims of this project were:

- To talk to local government representatives and others to hear their views and perceptions on how they can practically use the human rights framework to make the ‘universal access’ mandate of SDG 6 a reality; and
- To understand and map local government needs and preferences as the main audience for practical and accessible tools and materials for realizing the human rights to water and sanitation.

The project was undertaken by a consortium of WASH sector partners: WaterAid; WASH United; the Institute for Sustainable Futures (University of Technology Sydney); the Rural Water Supply Network (RWSN, Skat Foundation); and End Water Poverty. Forty two (42) respondents took part in semi-structured interviews with the project team or submitted short written surveys – 12 of these respondents were local government representatives and the remaining 30 were representatives from national government, civil society organisations (CSOs), donors, international organisations and consultants who work closely with local government partners / counterparts. All were asked about the level of understanding and perceptions of the human rights to water and sanitation and the potential for applying the rights at the local level.

In addition to the data collection process noted above, RWSN also hosted an e-discussion on “Local government and rural water services that last” in April-May 2015. Findings from the e-discussion are also included in this paper where relevant.

<sup>20</sup> de Albuquerque C (2014) Realising the human rights to water and sanitation: a handbook by the UN Special Rapporteur - Planning Processes, Service Providers, Service Levels And Settlements.

<sup>21</sup> Ibid. Available at: [www.ohchr.org/EN/Issues/WaterAndSanitation/SRWater/Pages/Handbook.aspx](http://www.ohchr.org/EN/Issues/WaterAndSanitation/SRWater/Pages/Handbook.aspx)

## EQUITY NON-DISCRIMINATION AND INCLUSION (ENDI)

### Universal Access & the Hard to Reach

This paper provides an overview of the views held by local government on the challenges they face as well as the enabling factors and actions that can support the application of the human rights to water and sanitation at the local level to achieve universal access to water and sanitation by 2030. As much as possible, this paper aims to present the voice of local government representatives with little accompanying analysis from the project consortium – in this way, the authors hope that other sector practitioners will hear this voice and be encouraged to plan their own WASH activities with a greater awareness of the situation many local government representatives face.

### Main results and lessons learnt

#### *There is a perceived low level of understanding of ‘water and sanitation services for all’*

Amongst the respondents there was a good level of familiarity with the notion of services ‘for all’, but often in cases where local governments were aware of the concept or perceived as being aware of the concept by non-local government interviewees, there was limited understanding of what it really means in practice, what mechanisms could be put in place to achieve it and the different levels of commitment to it. Some respondents understood that ‘for all’ meant reaching as many people as possible and also addressing equality by potentially targeting the most excluded people. However, the phrase ‘for all’ did not trigger a direct association with the human rights to water and sanitation in most responses.<sup>22</sup> Four respondents also noted that the lack of understanding around these human rights was leading to assumptions that water (and sanitation) should be delivered to everyone free of charge – without recognising the need to recover costs and to pay for operations and maintenance that would improve the chances of services being sustainable over the longer term. Overall, the concept of the human rights to water and sanitation was seen as burdensome and confusing.

When asked why some groups are often missed out or excluded from service delivery, respondents’ reasons included a lack of focus on marginalized people and the extra challenges associated with reaching vulnerable and excluded groups – for example, the roll-out of suitable technology, the higher costs associated with reaching people in more remote areas or challenging situations (e.g. water stressed regions or where there are conflicts or competition for resources) and to reach those in post-conflict areas.

Example local government respondent quotes include: “*This broad international goal has not been really explained to local government or local people*”; and “*when a project is carried in a given community, we think it’s a gift rather than a right that is being satisfied.*”

So, although the language of human rights<sup>23</sup> is not used widely, local government officials are aware of the concept of delivering services ‘for all’ and know that communities are entitled to clean water services. Several respondents highlighted that the concept of universal access may also be reflected in organisational mandates and initiatives. However, the challenge is that the use of the human rights framework is not clear; for example, although it can be used to steer planning and service delivery extension to excluded groups, it remains an abstract concept for many working at local government level. There may be no link made between the idea of services for all and the human rights framework – in addition, **local government representatives may not recognise themselves as the direct duty bearers of the human rights and therefore do not have a clear sense of their roles and responsibilities within the human rights mandate.**

There does appear to be an appetite for increasing the understanding of the human rights to water and sanitation and for clarification of some of the key components that can be practically used by local governments. Suggestions included:

---

<sup>22</sup> This question also highlighted that there was a greater focus on water for all rather than sanitation services for all; however, this could have also been to do with the selection of the respondents and their respective roles.

<sup>23</sup> Three local government representatives directly quoted the language typically used to explain the meaning of the rights to water and sanitation. For example, one noted that “*services should be equitable, affordable, accountable, participatory and sustainably managed*”, another highlighted the concept of non-discrimination, and the final one used the terminology of duty bearers and rights-holders.

## EQUITY NON-DISCRIMINATION AND INCLUSION (ENDI)

### Universal Access & the Hard to Reach

- Clarifying some of the fundamentals of the human rights to water and sanitation – for example, the meaning of ‘affordability of services’ (not free services), the use of subsidies, the concept of progressive realisation, etc.;
- Clarifying what each component means for different levels of government as duty bearers who can use these human rights as a supporting framework to achieve universal access;
- Documenting and sharing best practices and grounded examples of where the human rights to water and sanitation has been implemented to increase services to more marginalized or excluded groups;
- Clarifying the link to the SDG 6 indicators for water and sanitation and supporting local governments in understanding how they can undertake effective monitoring to assess progress towards achieving these human rights.

The project team is incorporating these insights and suggestions on how practical tools and materials could be designed into the next phase of the project.

#### **Who and what influences decision making about service delivery?**

So, if it is not the human rights framework driving decisions about service delivery, what is it that most influences access for excluded communities? Although it is hard to generalise across countries, levels of government, and rural/urban contexts, local government and non-local government respondents highlighted that it is typically **political leadership and political influence that actually determine what decisions get taken about where services are provided and to whom**. Respondents cited the influence and roles of district level leadership, traditional authorities, religious leaders, mayors and city councils as having political sway and decision-making power over service delivery agencies / providers and their budgets. One respondent noted, political interference plays a particularly influential role, *“sometimes also positive, but often negative”*. Clearly, **this has direct implications for sector organisations that are advocating for human rights-based approaches or are supporting the realisation of the rights at the local level**.

Respondents highlighted that political leadership is much more influential than the efforts of donors, development agencies and civil society and/or community demand. Similarly the impact of formal service planning processes and data collection (where it is available) for use in evidence-based decision-making about the location or extension of services to excluded groups is also reportedly low.

Several respondents were keen to note however the growing influence of rights-holders (i.e. people needing the services), especially where communities are engaging in governance and rights-based advocacy to challenge decision-makers by demanding that their rights are met. However, this has to be designed carefully within a given context – not only to address apathy but also to ensure advocacy work is appropriate. For example, one respondent noted, *“I may know that I have the right to demonstrate when I am not happy, but knowing that I will be tear gassed, then I may not do it. So a spirit of apathy... for that one [right], I let it go, I have no time for it.”*

Additionally, the influence of external development agencies (donors and NGOs) was noted as being positive from a rights perspective, as they are often able to engage well with local governments through capacity development programmes. Donors and development agencies are reportedly more influential in countries where there is high aid-dependency for WASH sector activities. Needless to say, the sample size for this research cannot provide definitive answers; rather these are the perceptions shared by the respondents on what influences service delivery ‘for all’ in their different contexts.

#### **What are the perceived challenges and barriers for achieving services for all?**

Although more than one respondent noted that water and sanitation face different challenges in different contexts, common issues came up across both. **Respondents typically discussed organisational or general WASH sector challenges that may be beyond their control** (e.g. an unstable political context,

## EQUITY NON-DISCRIMINATION AND INCLUSION (ENDI)

### Universal Access & the Hard to Reach

crack down on civil rights or advocacy, corruption or capture of service providers, etc.), rather than sharing their own personal challenges in their role and what they can do to reach universal access. This reinforced the sense that local government representatives do not necessarily regard themselves as duty bearers of the human rights to water and sanitation, even though they may recognise their *responsibility* in supporting the delivery of services to all. The connection between the two is not readily made – rather, respondents referred more to systemic or sectoral constraints that face them.

Given the variety and large number of challenges raised by respondents, the findings have been clustered into categories to provide an overview. Where relevant, these have been combined with findings from the RWSN e-discussion noted above.

#### *Socio-economic / socio-cultural factors and resource challenges*

- **Human resource and skills/capacity** challenges were mentioned by a large proportion of respondents (24) – as one respondent noted, “*people generally have good intentions. The resources, capacities, institutions are the problem*”. One respondent also noted that even in cases where there is availability of skilled staff, the challenge is to motivate them to stay in the hard-to-reach districts.
- **Financial and cost-recovery** challenges were also commonly raised across both water and sanitation (23 respondents), with sanitation particularly seen as under-resourced. There was a contrasting perception however (2 respondents) that “*there is a common misconception that lack of financial resources or inadequate allocations are the root of all problems, however this is not the case. The main challenge or barrier is lack of efficient and skilled human resources.*” Another respondent also noted that “*it is not about money*” and local governments need to be bolder (e.g. by enacting by-laws that set minimum standards). Political interference was noted regarding financial and cost-recovery aspects, including tariffs not being enough to recover costs, and heads of municipalities being resistant to the idea of increasing tariffs because it is not favourable to them politically. One respondent also noted that “*it’s difficult to get resources to fund operation and maintenance and post-construction work...it’s not politically marketable*”. Another respondent also noted the need for subsidy policies “*to be disconnected from political decision making processes.*”
- **Community awareness and behaviour change** challenges were discussed by many respondents (13). For example: the lack of community demand for sanitation services due to low levels of awareness of the hygiene and health links; cultural practices and beliefs; and an expectation that water and sanitation services should be provided for free, especially for the most marginalised or vulnerable people.

#### *Institutional arrangements and relationship challenges*

- **Lack of clear institutional responsibility for reaching excluded communities / people** (5 respondents), as often “*government roles and responsibilities are unclear... there is no accountability mechanism*” and “*sorting out who has the authority/obligation in a given context can be difficult*”. Unclear or uncoordinated roles and mandates between sectors and between different levels of government as well as the problem of ‘unfinished’ decentralization (whereby local authorities have the mandate but no budget autonomy) were also raised as challenges during the e-discussion. The online discussion also raised the topic of delegated or contracted management of services which shifted some of the roles and responsibilities of government to private operators / utilities; in such cases in France, Sweden and the UK, local government retains an oversight function.
- **Lack of implementation of inclusive policies and strategies** (4 respondents): “*although there are strategies written in paper, in practice these are not implemented*”. This is linked to a number of challenges reported such as lack of political will and leadership, political interference and lack of clear institutional responsibility.

## EQUITY NON-DISCRIMINATION AND INCLUSION (ENDI)

### Universal Access & the Hard to Reach

- **Limited local government authority or lack of an appropriate local government unit** (4 respondents), including cases where there is a hierarchical set-up and culture of respect within government, which provides little independence to local governments to take critical decisions and initiative. For example, *“national government has allocated an agency to act as local government but they have an implementation role and don’t influence policy.”*
- **Lack of legal recognition of slum areas** (2 respondents), which leads to government not being able to support these areas. One respondent noted *“these communities may simply be ‘off the radar screen’ for government institutions or wilfully neglected, as government authorities seek to make life difficult in order not to attract more people to those areas...this can also be driven by discriminatory attitudes, widely shared by government officials and/or deliberate government policy.”*

### Political economy challenges

- **Lack of a legal framework and policy direction** promoting water and sanitation services for all/equality (7 respondents). Although in some cases the human rights to water and sanitation are *“recognised in the constitution”*, these are not *“actualised in policies and actions”*.
- **Lack of political will and leadership**, were cited by the majority of the respondents (26 respondents) as big challenges for both water and sanitation. Linked to this, the political cycles and consequent changing local government priorities pose a challenge. Often *“priority is given to popular, highly visible investments such as roads”* and *“some politicians avoid enforcement regarding sanitation due to fear of losing votes”*. The particular challenge of governments regarding sanitation as a private matter was also mentioned. This hands-off approach can be *“regarded as community empowerment but also convenient, as governments can be fearful and hesitant of taking additional responsibilities.”*
- **Political interference and corruption** (9 respondents) were cited at the government level as well as at the community level, including the issue of *“powerful people not paying for tariffs”* or *“certain parts of the population taking advantage of the system”* in a way that affects its durability in the long-term and service provision to other sections of the community.

### Environmental / technical challenges

- **Geographic and technical/technology** issues (2 respondents), such as the lack of appropriate technologies, limited availability of land to build toilets, and difficult access for desludging trucks in urban high population density areas were cited as practical challenges faced by those trying to extend services to the poorest and most excluded communities. Water scarcity and competing demands for water also posed additional challenges.
- **Sustainability/long-term functionality of water and sanitation systems** (2 respondents) is hard to achieve in more remote or rural areas where excluded communities are unable to rely on local government (or other service providers) for operations and maintenance of their services.

Finally, a lack of, or inappropriate monitoring (2 respondents) of services that reach the most excluded, including difficulties in setting up appropriate indicators, and availability of resources for monitoring were highlighted as challenges for local government representatives.

### What can be done to build on enablers and opportunities to achieve services for all?

Some of the respondents reported enablers that were considered by others as challenges; this depended on whether the identified factor was helpful or not in their situation. For example, political will and interference, and monitoring were reported as enablers as well as challenges depending on the context.

## EQUITY NON-DISCRIMINATION AND INCLUSION (ENDI)

### Universal Access & the Hard to Reach

A key enabler to ensure services can be extended to all was to **have a clear, inclusive or rights-based institutional and policy direction** (9 respondents), including dedicated institutions, a strategic vision with a policy and legal framework, that “*creates options and conditions for people while not over-regulating them*”, and which does not leave the responsibility to deliver and maintain WASH services solely to communities. With a clear policy direction and **political will to enact inclusive policies** (2 respondents), there are more opportunities for extending services to the poorest and most marginalized. For example, one respondent noted that new settlements could generate political will if these are seen as opportunities for prestigious projects.

Another key factor is the **availability of financial resources** (5 respondents). The application of cost recovery principles in setting tariffs, as well as de-linking subsidies from political decisions are seen as enabling the realisation of services for all from a financial perspective. The role of development agencies in promoting cost-recovery principles was also noted.

Similarly, the **efforts of advocacy work and the presence of champions** (7 respondents) can support service extension to excluded communities and people. The idea of the need to be bold and/or to have a champion within government agencies also came through as critical to gain political traction. **How the message for ‘services for all’ is framed** and shared was also seen as critical. For example, not achieving equality can be framed as a risk, which can shift (and elevate) peoples’ perceptions of its importance. The need for good **communication and facilitation skills** was also highlighted as important in ensuring the message inspires enthusiasm and is not discouraging, as well as the importance of generating and providing evidence of the benefits of WASH and collaborating with networks of journalists for advocacy.

**Stakeholder engagement and coordination** (5 respondents) is also vital. For example, respondents noted the importance of local governments maintaining good connections with local chiefs, the existence of inter-sectoral teams at the district level, and ensuring women and people with disabilities are represented in local and national level decision-making processes.

To promote effective sector operations and coordination, **monitoring and accountability mechanisms** (6 respondents) are helpful and can be used cleverly in decision-making. For example, the opportunity for local government monitoring systems to drive progress if established with rights-oriented indicators was mentioned. Also, the role of women’s groups and youth groups was noted as “*highly important in autonomising to contribute finance for sanitation and to hold government to account.*”

The **role of donors and NGOs** (3 respondents), particularly in providing capacity building, advocacy and strengthening professional associations is important when seeking to extend services to all. External funding and support from donors with a specific aim to provide water and sanitation services to poor sections of the population was mentioned as a way of promoting a better understanding of poor peoples’ rights to access services.

Again, these types of opportunities and enablers can prove useful when considering programme design and when taking service extension decisions – they can also encourage others to use such mechanisms to advocate for universal access in practical and useful ways.

### Conclusions and Recommendations

The research intended to highlight the realities facing local government representatives in understanding and implementing the human rights to water and sanitation at the local level. Although respondents were familiar with the notion of services ‘for all’, there was limited understanding of what this really means in practice and how it might relate to the human rights framework. In addition, the language of rights is not widely used or understood to have any relevance to water and sanitation. Recognising and accounting for these realities is the main recommendation for WASH sector practitioners from this project.

## **EQUITY NON-DISCRIMINATION AND INCLUSION (ENDI)**

### **Universal Access & the Hard to Reach**

In terms of extending services to vulnerable or excluded people, it is typically political leadership and political influence that determine what decisions get taken about where services are provided and to whom. There are many perceived challenges and barriers for achieving services for all – many of these are externalized or sectoral constraints and regarded as being beyond the scope or remit of individual local government representatives. The research found that a key challenge is that local government representatives may not recognise themselves as the direct duty bearers of human rights – hence their roles and responsibilities are unclear.

However, the respondents also suggested ideas and opportunities for addressing some of the barriers to extending services to all. Efforts to improve the enabling environment for achieving access to all is vital – such as supporting the creation or strengthening of inclusive policies and strategies, understanding the value of political will and using it, ensuring finance is available and proactively using information from monitoring systems. Additionally, advocacy and influencing work can help to strengthen the voice that calls for universal access, notably through supporting the engagement of people who are regarded as vulnerable or marginalised in decision-making so that they can call for their rights to be upheld. Similarly, the call for universal access can be made louder through engagement with influential stakeholders – ranging from journalists, to local chiefs, donors or NGOs.

Clearly, the barriers and opportunities highlighted above have direct implications for sector organisations seeking universal access through advocating for human rights-based approaches or who are supporting the realisation of the rights at the local level. The project team hope that WASH sector practitioners will hear this voice and be encouraged to plan their own work with a greater awareness of the situation many local government representatives face.

### **Acknowledgements**

Thanks also to: Kerstin Danert, RWSN for supporting and hosting a related e-discussion; Marieke Adank, IRC for leading the e-discussion; and Artur Matavele, Munawar Hassan and Landry Ouangre for helping to carry out some of the interviews.



EQUITY NON-DISCRIMINATION AND INCLUSION (ENDI)

Universal Access & the Hard to Reach

---

# Inclusive Water Supply and Sanitation Services Provision for Indigenous Peoples in Latin America and the Caribbean

---

## Authors

Clémentine Stip

Junior Professional Associate, Global Water Practice, World Bank

United States; [cstip@worldbank.org](mailto:cstip@worldbank.org); (202) 473-3438

Lilian Pena Pereira Weiss, Dianna Pizarro, Ximena Traa-Valarezo, Miguel Vargas, Ella Lazarte, Sophie Theis, Elizabeth Eiseman

## Abstract/Summary

In Latin America, extending the human right of access to WSS services to Indigenous peoples represents the final step for many countries to reach universal coverage. In general, the sector has lacked a general participatory framework and a particular set of principles to guide the stakeholder engagement processes and the participation strategies for sustainable outcomes of WSS projects in Indigenous areas. This paper provides practical guidance and operational tools to improve the effective inclusion, engagement and delivery of sustainable WSS investments services *with* Indigenous Peoples. It compiles lessons learned and good practice from throughout the Latin American region, drawing from the visions and experiences of Indigenous groups and organizations, WSS agencies, NGOs, and development partners. The findings of the field work are organized around three concepts essential to ensure effective engagement with Indigenous peoples: Respect, Ownership and Sustainability, and they follow the sub-project cycle for direct application for field practitioners.

## Introduction

The World Bank estimates that 43 percent of the approximately 42 million Indigenous peoples in LAC live in poverty and that 24 percent live in extreme poverty. (World Bank 2015) These poverty rates are more than twice the levels found among the non-indigenous population. While the number of Indigenous peoples living in poverty has fallen over recent years, the poverty gap between Indigenous and non-indigenous Latin Americans has stagnated or, in the worst cases, widened.

In LAC, Indigenous peoples are 10 to 25 percent less likely to have access to piped water and 26 percent less likely to have access to improved sanitation than the region's non-indigenous population. (LAC Equity Lab 2015) Lack of access to WSS services perpetuates chronic poverty by contributing to poor health, infectious skin and gastrointestinal diseases, and malnutrition, among other ailments. Extending the human right<sup>24</sup> of access to WSS services to Indigenous peoples represents the final step for many LAC countries to reach universal water coverage.

To effectively and permanently close this coverage gap, LAC countries need to extend WSS services sustainably and inclusively to Indigenous communities. Local service providers in Indigenous communities have historically been more likely to “slip” into failed service provision than in non-indigenous communities.<sup>25</sup> Studies show that adoption<sup>26</sup> and use of WSS systems is lower and slower in

---

<sup>24</sup> In 2010 the United Nations (UN) Resolution 64/292 acknowledged that clean drinking water and sanitation are essential to the realization of all human rights.

<sup>25</sup> Data from the *Sistema de Información de Agua y Saneamiento Rural (SIASAR)*, a regional information system owned and managed by member countries to track rural WSS indicators related to access, quality of services and overall sector sustainability. See Annex 5 for more information on SIASAR.

## EQUITY NON-DISCRIMINATION AND INCLUSION (ENDI)

### Universal Access & the Hard to Reach

Indigenous communities largely because of investors’ and service providers’ lack of knowledge and limited attention to Indigenous peoples’ unique social and cultural characteristics. Oftentimes, Indigenous territories are overlooked by WSS project teams given their uncertainty over how to carry out projects in Indigenous territories, the remoteness of these areas, and the high associated per capita cost of a potential operation, among other reasons. In general, the WSS sector has lacked a participatory framework tailored to Indigenous peoples with specific principles to guide stakeholder engagement processes, participatory strategies, and the selection and implementation of investments to promote sustainable outcomes for WSS projects with Indigenous peoples.

The objective of the Toolkit on “Water and Sanitation Services: Achieving Sustainable Outcomes with Indigenous Peoples in Latin America and the Caribbean” is to provide practical guidance and operational tools to promote the inclusive delivery of sustainable Water Supply and Sanitation (WSS) services to Indigenous peoples in Latin America and the Caribbean (LAC). This paper outlines the main findings of this research.

### Description of the Case Study – Approach or technology

This paper draws on the findings of interviews, consultations, and field visits carried out in 37 Indigenous communities<sup>27</sup> in seven Latin American countries (Panama, Nicaragua, Paraguay, Argentina, Peru, Colombia and Bolivia) where the World Bank or other development actors have implemented WSS projects. A multi-disciplinary World Bank team, which included WSS engineers, anthropologists, social specialists and economists, among others, carried out the fieldwork. Through interviews with all the stakeholders (governments, WSS institutions including their decentralized units, Indigenous organizations, NGOs, other development agencies and beneficiaries) involved in the roll-out of these projects, this on-the-ground work was able to synthesize lessons learned from a range of perspectives from actual interventions. The lessons from the field presented herein also build on a desk review, interviews with WSS and Indigenous peoples experts, and consultations with Indigenous representatives outside of the countries chosen for the field visits.

As opposed to other low-income groups, Indigenous peoples often: (i) subscribe to organizational and governance structures that are different from the rest of society; (ii) maintain extensive traditional knowledge around their land, natural resource base, and environment; (iii) utilize unique practices and cultural norms around water collection, storage, distribution, sanitation and hygiene; and (iv) hold strong beliefs and practices around the well-being of the collective versus the individual, leading to a higher degree of social cohesion, unique traditions and structures of community organization, and different norms around communal contributions. The recommendations highlight specifically how to take these characteristics into account in the delivery of WSS services to Indigenous peoples.

### Main results and lessons learnt

Three key principles of engagement are identified for carrying out successful WSS projects in Indigenous territories: **respect**, **ownership** and **sustainability**. When Indigenous peoples actively participate in the development of a WSS project and their traditions and organization structure are **respected** throughout the project cycle, they are more likely to develop **ownership** over the services and the results tend to be **sustainable** over time. This paper provides concrete recommendations on how specialists designing a WSS project in indigenous areas can best incorporate these principles throughout the project cycle. This paper targets project managers and field practitioners tasked with the implementation of WSS interventions in Indigenous areas, but it also provides guidance for policy makers and Indigenous leaders

---

<sup>26</sup> Adoption means the acceptance of and ownership over a given WSS system, including community consultations, understanding of water-related diseases and health consequences of poor WASH, construction and future operation and maintenance.

<sup>27</sup> The communities were located in rural, peri-urban and urban settings in order to ensure the widespread applicability of these recommendations.

## EQUITY NON-DISCRIMINATION AND INCLUSION (ENDI)

### Universal Access & the Hard to Reach

aiming to articulate specific demands from the WSS sector in their countries. The full Toolkit document addresses these issues from the perspective of project teams in more depth.

**Respect** requires the recognition of Indigenous peoples’ unique and valuable world views and forms of organization through their active involvement throughout the project cycle.

*WSS sector institutions need to build a dialogue with Indigenous organizations to ensure that Indigenous priorities are meaningfully integrated in the sector.* Indigenous authorities at national and regional levels have the capacity and interest to define sector priorities, develop policies, and prioritize investments, and should play an active role in the design and implementation of projects that would benefit their populations. These priorities can be articulated in a jointly developed national strategy that outlines a methodology for fair and transparent investment targeting, project implementation, and specific relevant cultural dimensions. Field visits revealed varying levels of such coordination that was seldom recorded through official strategies or articulated sector priorities. For example, in Bolivia, there are limited national policies or programs that ensure the Indigenous cultural adaptation of methodologies for WSS projects, despite existing ties between Indigenous organizations and the national government. However, Bolivia does have a well-developed regulatory framework for the WSS sector that requires the application of community development and training methodologies, incentives and requirements for the establishment and legalization of water committees,<sup>28</sup> and a specific menu of WSS alternatives. This well-developed tool provides a strong platform for the adaptation of Indigenous-specific consultation approaches, as it already mandates thorough engagement with beneficiary communities.

*WSS sector institutions need to specifically target investments to Indigenous territories and tailor approaches for engagement, intervention design, and operation and maintenance support to these territories in order to close current regional coverage gaps.* The lack of articulated strategic documents setting specific targets and rules for WSS sector interventions in Indigenous areas hampers this allocation. Oftentimes, national and regional Indigenous organizations can also facilitate the communication between individual Indigenous communities, central governments and funding agencies to ensure the community’s needs are prioritized. A thorough understanding of the traditional forms of organization at the local level, how communities communicate their demands, and what bodies represent these demands is essential for respectful investment prioritization. If tensions are unveiled between organizations, guiding factors should be based on levels of representation and technical, economic, or other criteria used for investment choices.

In Nicaragua, Municipal Plans were elaborated to assess community WSS needs in each municipality and prioritize the most urgent interventions. Through a questionnaire, the project team calculated a series of indicators that yielded a “priority score.” The highest priorities in the municipality were then chosen based on funds availability, and the final list validated by the Territorial Governments and independent Regional Governments. The use of a scoring system enabled the project team to choose communities based on a verifiable set of factors. Developing a thorough information systems with indicators on WSS coverage and management practices can also help project teams identify the neediest communities and elaborate alternative intervention mechanisms, such as institutional strengthening and training on specific WSS aspects that service providers are failing on, for example. Validating the list of prioritized communities with the relevant national and regional Indigenous organizations ensures their support of the intervention, alignment with their vision for territorial development and respect of the traditional structures.

In addition, WSS institutions need to hire social specialists and engineers with the capacity to work with Indigenous peoples and/or provide specialized training to current staff. Institutions can strengthen their implementation teams by: hiring specialized consultants, collaborating with an organization that has this expertise, or implementing a special training program for the existing engineering and social teams. In Paraguay, Asunción-based *Servicio Nacional de Saneamiento Ambiental* (SENASA) successfully hired a consultant specifically to manage Indigenous topics in El Chaco (this person identified as Indigenous and had particular knowledge on the area of intervention), and in Argentina, the project team hired the NGO

---

<sup>28</sup> Community-based organizations composed of community members who volunteer to manage their WSS systems.

## EQUITY NON-DISCRIMINATION AND INCLUSION (ENDI)

### Universal Access & the Hard to Reach

*Fundación Gran Chaco* to support the application and monitoring of social processes. Alternatively, the project team can establish agreements directly with Indigenous organizations to support cultural mediation and engagement with communities. This can help increase ownership at many levels and serve to build longer-term capacity for Indigenous organizations as active partners in WSS projects. Regardless of the approach, the consultants, organization, or newly specialized staff should oversee the consultation process and ensure that the beneficiaries’ (and traditional authorities’) inputs are the basis of the decision-making process.

**Ownership** builds on the principle of respect for engaging with Indigenous peoples and allows a community to recognize the value of WSS services and take responsibility to design, implement, use and maintain its WSS system accordingly.

At the community level, Indigenous beneficiaries and their local traditional authorities must be involved in all key decision making processes throughout the development and implementation of WSS projects to ensure that the intervention meets community needs and respects their world vision and cultural practices. A successful engagement strategy respects traditional hierarchies and cultural preferences in establishing clear rules for: participation, communication of key information among stakeholders and decision-making processes. Informed consultations are a two-way street: project teams provide information on the potential project and receive inputs and participation commitments from potential stakeholders and beneficiaries. This participation can take the form of conversations about the project with a platform for questions and answers, feedback provision by the future users and approval of key decisions. When well-conducted, consultations also avoid miscommunication around the intentions of the project team and the availability of resources. The consultation process is essential in building trust where there might be fundamental disagreements (between central government and Indigenous organizations for example) and in ensuring that local knowledge is respected and incorporated into projects.

In La Guajira, Colombia, the Regional Government, *Gobernación*, imposed that no requests be made of beneficiaries until they could see the physical system working, under the assumption that Indigenous beneficiaries would not believe a system was coming or want to contribute to its construction until that moment. The project team respected this request and worked with Indigenous authorities and local NGOs to agree on system type and carry out the whole intervention, and only involved beneficiaries once results were visible. These idiosyncrasies require flexibility on the part of project teams to assure community members of the beneficial nature of a project through information sessions at project onset.

A demand-responsive approach is essential for building ownership. However, it should be tailored to Indigenous contexts by providing technological options based on traditional knowledge and culturally appropriate community contribution schemes to foster ownership. In Bolivia, the NGO Water for People carries out a diagnostic of community needs and refines the intervention design in that community accordingly. This strategy effectively involved beneficiary communities and built on the communities’ value system of collective wellbeing. The demand-responsive approach (DRA) applied by Water for People led them to 1) meet the demands of the community in full, leaving no beneficiaries behind, and 2) foster collaboration with the beneficiaries from an early stage, respecting their vision for their own development. In contrast, in the fieldwork for this toolkit, other programs were visited where the project prioritization and design had minimal, if any basis, on the diagnostic of community needs. The results were lamentable, with toilets built for empty homes and inhabited homes excluded from benefits. To avoid such pitfalls, social assessments must incorporate practical WSS-related questions beyond cosmovision and natural resources to provide a representative snapshot of the state of WSS and hygiene behaviors and preferences within a community.

Women are strong behavior change agents and keepers of traditional knowledge. Women should be engaged from project onset so that their views and local know-how can be incorporated throughout project life. Gender dynamics differ between Indigenous communities and cultural norms require specific strategies of engagement with women. This desire was voiced repeatedly during field visits. Some Aymara communities in the Bolivian highlands left all decision-making to women and refused to allow men on their WSS committees, whereas in Ecuador sometimes women are not allowed to speak in public but will influence and have the final say in decision-making once outsiders have left the community. Ideally, a

## EQUITY NON-DISCRIMINATION AND INCLUSION (ENDI)

### Universal Access & the Hard to Reach

thorough consultation process will provide space to discuss women's concerns and needs and ensure they are incorporated in subsequent steps of the project cycle. However, a community's specific cultural norms around gender will influence a project team's ability to carry this out. In the Paraguayan Chaco, Ayoreo women demand to be approached first when projects involve WSS, even before the community's leaders, because they are traditionally in charge of managing those resources. In this case, parallel consultations for men and women were recommended, but project teams should make sure to verify that traditional authorities are informed and supportive before taking such measures.

**Sustainability** in the provision of WSS services requires user ownership combined with specific, institutionalized mechanisms for O&M that reflect Indigenous peoples' customs and norms, including tailored technical assistance and active beneficiary involvement.

*To avoid the failure of WSS services over the long-term, adequate time and resources have to be invested in the “soft” side<sup>29</sup> of these interventions* to promote a respectful approach and the development of ownership by Indigenous beneficiaries. Consultations and knowledge of local traditional structures should inform the design of sound management structures for the WSS services, for example to create and build capable and credible local water committees with sustainable financing arrangements. Though field work did not evidence a one-size-fits-all solution for management of WSS services in Indigenous communities, successful service provision and management models visited all involved entities with clear communication mechanisms with the WSS services users, taking into account traditional authorities and trainings to build capacity where needed. In rural areas, the most successful management was done through WSS committees with clear statutes and regulations, with support (regular quality technical assistance) from an outside entity (municipal WSS unit or NGO). In more concentrated areas, the most effective WSS management model may be to collaborate with a water utility equipped with a strong social team with Indigenous peoples expertise. The presence of a well-defined management model that is appropriated by the community is a key element to service sustainability as it increases the likelihood that the users will be committed to paying for services to support continuous O&M of their systems.

Though there is a general perception that Indigenous peoples should not and do not want to pay for WSS services, findings reveal that Indigenous beneficiaries recognize the importance of WSS services and are willing to provide some kind of contribution to their sustainability, through either monetary or “alternative” payment models (such as in-kind work or locally-produced materials). In Panama, IDAAN representatives affirmed that in Colón's peri-urban area Indigenous peoples were actually the only users who paid for their water service on time. In Bolivia, all water committees visited charged tariffs (though some of them charged fixed amounts every month). Charging monetary tariffs, however, is not the only way Indigenous peoples can cover service provision costs. There are other culturally acceptable mechanisms, such as organizing a fair (*minga*) to raise funds when the system needs repair, or exchanging natural resources or goods, such as wood or a chicken, for the monthly payment. These contributions have to remain meaningful and contribute to the functioning of the system. The most effective non-monetary contribution remains time and labor for the operation and maintenance of the system. The community can establish a schedule wherein different tasks are assigned to participating community members in exchange for water service. These may be relatively simple but essential tasks, such as distributing water bills or doing house visits to share specific information to users, or more technical tasks that require specific training (chlorinating the water, opening and closing valves, keeping the books of the water committee). If the community decides to use this approach, training needs can be identified through consultations early on to ensure all community members are equipped to carry out relevant tasks. In the community of Boquerón Alto, in Bolivia, all community members attended technical trainings so that water committee members could rotate every year to anyone in the community.

The sustainability of decentralized services requires the establishment by the WSS sector of technical assistance and institutional support mechanisms in particular for the O&M phase, involving periodic site visits, just-in-time professional support, and the mobilization of external parties, as necessary. In

---

<sup>29</sup> As opposed to the “hard” or infrastructure side of interventions, the “soft” side consists in all the social, technical and capacity-building work carried out in addition to infrastructure delivery.

## EQUITY NON-DISCRIMINATION AND INCLUSION (ENDI)

### Universal Access & the Hard to Reach

Indigenous areas, this regular technical support should work with existing traditional structures, aim to strengthen local capacity, and be defined through consultations. Technical assistance providers who work in Indigenous communities must:

- Understand the region and its context.
- Understand the local social fabric and be able to identify and recognize the appropriate organizational structures.
- Respect the indigenous community’s cosmovision and promote its inclusion in technical solutions.
- Speak the local language and/or learn pertinent communication mechanisms.
- Plan according to a timeline that takes into account the local customs and does not jeopardize achieving the technical assistance goals.
- Understand the local way of life and promote its respect in design processes.
- Take cultural uses of the land (sacred spaces, for example) into account in solutions identification.

Although the National Rural Sanitation Program (PNSR) is a government program that provides technical assistance in the implementation of WSS works in rural areas throughout Peru, the PNSR’s personnel in the Peruvian Amazon – a region with a high concentration of Indigenous communities – presented the characteristics listed above and truly connected with the beneficiaries they worked with. Staff interviewed during field work showed they had earned the local Indigenous communities’ trust by working with them for a long time, spoke the local language, coordinated directly with the traditional authorities (Apu) who worked closely with the water boards, and were regularly informed of local traditional meetings, their development, and their issues of interest.

### Conclusions and Recommendations

The team found that these essential components of project sustainability were not always present in the field visit cases. In particular, the lack of articulation of priorities for the sector in Indigenous areas and specific methodologies to address them left a serious need for better coordination among stakeholders. On the other hand, where some of these key steps were being implemented, they often missed other important components for a holistic, successful engagement. The team believes that providing a comprehensive framework for collaboration with dispersed rural Indigenous communities<sup>30</sup> in sustainable WSS service delivery is critical to consolidate existing knowledge in this sector and connect practitioners with tools to overcome constraints and knowledge gaps in order to better serve marginalized Indigenous communities.

### Fact-Checking

The fieldwork carried out for this Toolkit challenged several commonly held stereotypes on Indigenous communities’ WSS preferences and habits.

**Reluctance to use and adopt sanitation solutions by Indigenous peoples.** It is common to hear that Indigenous peoples will resist using toilets because of their centuries-old open defecation practices. *In fact, field experience revealed that when social and engineering work is done well, with thorough iterative consultations, tailored sanitation solutions, and community capacity building (in particular involving women), Indigenous peoples demand, adopt and use sanitation solutions.*

---

<sup>30</sup> Though the field work involved visits to urban, peri-urban and rural settings, the team found that those Indigenous peoples living in the most remote areas maintained their cultural norms and practices the most, while those closer to cities considered themselves less Indigenous. As such, the recommendations of this Toolkit are tailored to rural Indigenous peoples, though they also applied in some peri-urban cases such as Panama and Bolivia.

## EQUITY NON-DISCRIMINATION AND INCLUSION (ENDI)

### Universal Access & the Hard to Reach

**Rejection of piped water and water treatment.** It is often said that Indigenous peoples reject piped water systems and water treatment because piping or treating the water would change its natural composition. *In fact, if the community receives appropriate training, preferably in their local language, on the health benefits and comfort associated with a piped water supply and water treatment, Indigenous peoples demand, appreciate, and are willing to contribute (either financially or through other means) to an improved water system.*

**Unwillingness to pay for water services.** Many people believe that Indigenous peoples are not willing to pay for water services. *Contrary to popular belief, Indigenous peoples are ready to contribute to WSS services projects and their operation, either in monetary or in-kind contributions. In fact, in many cases, Indigenous peoples are keen on having water meters to promote rational water use and equitable water sharing among the families.*

And finally,

**Working with Indigenous peoples is too complex and difficult to achieve desired outcomes.** Initially, engaging with Indigenous peoples may appear overly complex due to the additional layers of coordination required and the need for a customized approach. *When treated as development partners, Indigenous communities actively pave the way for successful project delivery. So long as the Indigenous traditions and organizational structure are respected, the projects are defined with Indigenous peoples' active participation, and ownership for the WSS system is established, project development and implementation tends to be smooth and the results tend to be sustainable. Project teams need to allocate time and resources for a demand-responsive approach to project design, implementation, and evaluation that respect the specificities of Indigenous community practices and organization. It is true that WSS services in Indigenous communities require unique and flexible approaches with specialized knowledge of the community, but it is not significantly more complex or time-consuming than a demand-driven approach to providing WSS services to other communities. The elaboration of a country-specific strategy and implementation methodology agreed between WSS sector institutions and Indigenous organizations will also streamline these processes. Furthermore, success is possible, sustainable, and extremely impactful when the project respects Indigenous actors and creates ownership over the intervention.*

### Structural Barriers

Beyond the practical and on-the-ground recommendations provided in the Toolkit, it is important to recognize that complex social, political, and institutional structural barriers still jeopardize the effective application of the key principles and actions of a sound engagement with Indigenous peoples. On the one hand, these barriers are rooted in centuries of tense relations between Indigenous peoples and Governments; on the other, they also relate to recurrent institutional challenges strongly present in the Social Development and WSS Sectors beyond working with Indigenous peoples.

**Historical discrimination against communities outside of the mainstream** recurrently leads to their lack of voice, political representation and economic power. This social exclusion has been institutionalized through representation structures and investment prioritization mechanisms in many LAC countries. Though for Indigenous peoples this is slowly changing through the legal recognition of their rights, this has yet to truly transition to practice so that Indigenous peoples may enact their vision for their own development.

**Weak institutional structure for Indigenous representation and for the WSS Sector, which usually renders institutions on both fronts unable to respond adequately to Indigenous peoples' demands.** In most of the countries in LAC, the institutional structure to support the development of policies and the implementation of key Indigenous engagement principles (such as recognizing land rights, traditional indigenous organizations, and carrying out meaningful consultations, among others) is either weak or non-existent. The lack of definition of key aspects such as tenure laws and resource management often creates severe obstacles for the development of systematic interventions at scale in Indigenous areas.

Similarly, although most countries have a well-defined arrangement for WSS services provision in urban areas, the rural WSS institutional arrangements (particularly relevant considering that most Indigenous peoples live in remote rural areas) are frequently dispersed, under-staffed, under-funded and under-represented in the higher-level Government structures. Additionally, institutions often **lack specific**

## EQUITY NON-DISCRIMINATION AND INCLUSION (ENDI)

### Universal Access & the Hard to Reach

**knowledge to work in remote and unique social-cultural environments**, thus demotivating them from engagement or making their engagement less effective. The institutional development barrier is often associated with a **political system that rewards physical interventions**, which tend to be located in populated and accessible urban areas. The majority of funds and overall institutional efforts in the WSS Sector still go to urban areas, which are more easily reached and generate quicker, cheaper results and political visibility.

Changing the mindset of political leaders in order to prioritize investments and institutional efforts towards the most vulnerable, traditionally excluded, and poor communities (namely, Indigenous peoples) is a long-term transformational process that requires strong leadership and targeted knowledge. Higher-level advocacy work, such as international agreements like the Sustainable Development Goals supported by the United Nations or collaboration with international development partners, could help re-direct efforts to the most needful areas and supply open-minded political leaders with the knowledge and tools to break through these barriers and promote inclusive development for their countries.

### References

World Bank (2011) ‘Indigenous Latin America in the Twenty-First Century.’ Washington, DC: World Bank.

World Bank LAC Equity Lab (2015). Accessed at:

<http://globalpractices.worldbank.org/teamsites/Poverty/LACDataLab/Site Pages/services.aspx>



EQUITY NON-DISCRIMINATION AND INCLUSION (ENDI)

Universal Access & the Hard to Reach

## Assessing water service coverage by placeholders: a social media simulation

Type: Long Paper

**Authors:** <sup>1</sup>Christina Geoffrey Mandara\*, <sup>2</sup>Ron Van Lammeren and <sup>3</sup>Anke Niehof

<sup>1</sup>\* Lead/Corresponding author, Lecturer at the Institute of Rural Development Planning-Dodoma, Tanzania. Contacts: [tinagm\\_2004@yahoo.com](mailto:tinagm_2004@yahoo.com), +255764561108

### Abstract

This paper presents the simulation of a social media approach to assess village domestic water services coverage by using a combination of known methods to capture placeholders. Placeholder is location based information given by local people who are familiar with a specific area due to a longer period of living in, using and managing that area. Placeholders as such represent experiences and perceptions of local people. This simulation has been realized during 2011-2012 in the Kondoa district of Dodoma region Tanzania to find out in what way local communities may support water services given the options of upcoming mobile technologies. Simulation has been done by collecting data through sketch mapping, geocoded transect walk, focus group discussion and cross-checked by interviews. Results of the simulation show that this type of community water service mapping supports collection and validation of relevant, accurate and representative information on water service coverage at village level. It depicts the intersections between seasonality and accessibility to water services, revealed yet unreported intra-village variation and has added value for updating the status of water services and assessing their adequacy at the village level, in the light of population change and development of new settlements. Regarding social media the acquisition and control of point based waterservice facilities may be an easy first step to set. However the link to a wider community accepted spatial context and options to update village demographics and settlements demand for baseline data and inclusion of social infrastructures.

### Introduction

Domestic water is a crucial input and resource for a household’s livelihood activities, health and sanitation needs. In Tanzania the proportion of the rural population with access to potable water services has been gradually increasing from about 46% to 57% during the 1990s to 2010 (URT<sup>31</sup>, 2002, 2009a, 2010a, 2011a; MoWLD et al., 2002). However, about 40% of the rural water schemes are not functioning properly due to hardware problems, sources being dry and poor management (Giné and Pérez-Foguet, 2008; Taylor, 2009a, 2009b). Non-functional water schemes disrupt water access indicators guided by the 2002 national water policy. That policy defines water as accessible when one water point serves 250 persons within a distance of 400 meters and users spend no more than 30 minutes for a round trip (URT, 2002, 2008a, 2010c, 2012). A water collection round trip is defined as going to the source, waiting in line to collect water and coming back to the house. Moreover, studies indicate under-reporting of the non-functionality and over-reporting of service coverage in terms of accessibility (URT, 2010b; Welle, 2010). This leads into inaccurate information which interferes the sector’s management for many years (MoWLD et al., 2002; URT, 2010b; Jiménez and Pérez-Foguet, 2010a, 2010b, 2011b).

To address the problems on information anomalies in the water sector, water point mapping (henceforth WPM) was introduced (URT, 2010b, 2011b; Jiménez and Pérez-Foguet, 2011b). The WPM approach was designed by WaterAid to measure access indicators for improved water points in a specific area (Stoupy and Sudgen, 2003). WPM supports visualisation of the relationship between physical and socio-economic factors related to access to water and reveals patterns that would otherwise be difficult to see (MacDonald et al., 2009). In Tanzania since 2000s, WPM has been used by international and local organisations working with water and development sectors such as WaterAid, Stichting Nederlandse Vrijwilligers

<sup>31</sup> URT stands for United Republic of Tanzania

## EQUITY NON-DISCRIMINATION AND INCLUSION (ENDI)

### Universal Access & the Hard to Reach

(SNV) and the resident Ministry of Water (Welle, 2005, 2010; SNV-Dar Es Salaam-TZ, 2010; URT, 2010a). WPM has been applied in other African countries including Ethiopia, Ghana, Nigeria, Malawi, Uganda and Kenya (cf. MacDonald et al., 2009; Welle, 2005, 2010). Most of the WPM applications in Tanzania have been done beyond village level, on an ad hoc basis, and is neither well consolidated at the national level nor regularly updated (Jiménez and Pérez-Foguet, 2010a, 2010b; URT, 2010a). Previous studies on WPM (Jiménez and Pérez-Foguet, 2008, 2010a, 2011a, 2011b) do not explicitly show how villages and households participate. Therefore, the outputs from WPM is likely to miss processes at the micro level i.e. villages and households; because its applications lack inputs from the actors who are local service managers and users. These inputs we call placeholders; actual location based information given by local people who are familiar with a specific area due to a longer period of living in, using and managing that area. Placeholders as such represent knowledge given experiences and perceptions of local people (Vervoort et al., 2013). Placeholders may overcome mismatches regarding local in time needs due to questionable validity of the information in terms of relevance, correctness and representativeness.

Additionally, villages depend on the District Water Department (henceforth DWD) for technical expertise when their water infrastructures break down. To get the required assistance members of the VWC inform the Village Executive Officer who then notifies the District Water Engineer (URT, 2010a). In these procedures location based information is rarely used because it's hardly available at the district and village levels. If it is; it is fragmented, outdated, poorly accessible, or not in standardized formats, which hinders timely and appropriate interventions.

Besides, the DWD uses population size from census and national surveys such as the Household Budget Surveys and the Health and Demographic Survey to plan for village water projects. These figures tend to be outdated because Tanzania conducts a census once every ten years and the surveys are scheduled in different periods. To actualize population's information, the DWD makes projections. Such projections estimate population size rather than its composition and spatial distribution, which are much affected by internal migration. This information's weakness, compromises achieving the national standards which depend on population size and distribution to determine accessibility to water service.

Thanks to the development of information and communication technology the setting of information exchange is changing dramatically. In Tanzania the 12 network operators did expect that by 2015 40% of the area and 80% of the population may be covered (<http://www.africamobilenetworks.com/our-coverage/tanzania>). Such mobile network coverage gives way to liberating GIS technology (Sui, 2015) in which social media (Waal et al., 2013) may support actual information on local water services by tackling the previously mentioned issues. Placeholders may help to rectify information irregularities in the rural water sector. This calls for an approach which we call Community Water Service Mapping (CWSM). CWSM simulates social media needs to find out if placeholders can be created. CWSM addresses the following questions: (1) what is the added value of the CWSM approach to assess water services coverage at village level? and (2) how do methods and processes involved in the CWSM enhance the relevance, accuracy and representativeness of micro-level information?.

### Community water service mapping: a theoretical framework

The base of the intended social media should be grounded in community mapping (Amsden and VanWynsberghe, 2005). Community mapping produces maps which communicate information that is shared, relevant and important to the community needs based on open, interactive, transparent and inclusive processes (Parker, 2006; Corbett and Rambaldi, 2009). Community maps are made through the participation of community members who live in and do know the area. In this way they may co-create and locate, by visualising as map, micro-level, up-to-date information (Glockner *et al.*, 2004; Corbett and Rambaldi, 2009). As such this placeholders represent micro-level understanding on their locality that enhances the power and capacity of the local community (Amsden and VanWynsberghe, 2005). This approach has been advancing parallel to critical cartography and participatory Geographical Information Systems, and, recently, qualitative GIS (Elwood, 2006; Parker, 2006; Corbett and Rambaldi, 2009; Elwood and Cope, 2009; Wilson, 2009, Sui, 2015). Besidesthere is scant academic literature showing the application of community mapping in rural-public domestic water services.

## EQUITY NON-DISCRIMINATION AND INCLUSION (ENDI)

### Universal Access & the Hard to Reach

CWSM in this study views villages as heterogeneous and dynamic entities in terms of population composition, size and spatial distribution. Besides, the methodology is attributed by its capacity to elicit users’ perspectives on the spatial aspect, which are not easily captured through other methods of data collection such as a household survey (Cleaver and Elson, 1995; Glockner *et al.*, 2004; Amsden and VanWynsberghe, 2005). In our study, CWSM merges and integrates three methods: Focus Group Discussion, participatory sketch mapping, and geo-coded transect walk. The triangulation by combining these methods enhances information validity in terms of relevance, accuracy and representativeness (Figure 1). In line with the concepts of geo-information placeholder relevance refers to actuality of the information, since CWSM connects the source of information with the current state of micro-level features and phenomena. Accuracy of the gathered information refers to the quality of the described states, events and locations. Representativeness of the information refers to the daily lives importance and link to (concerted).

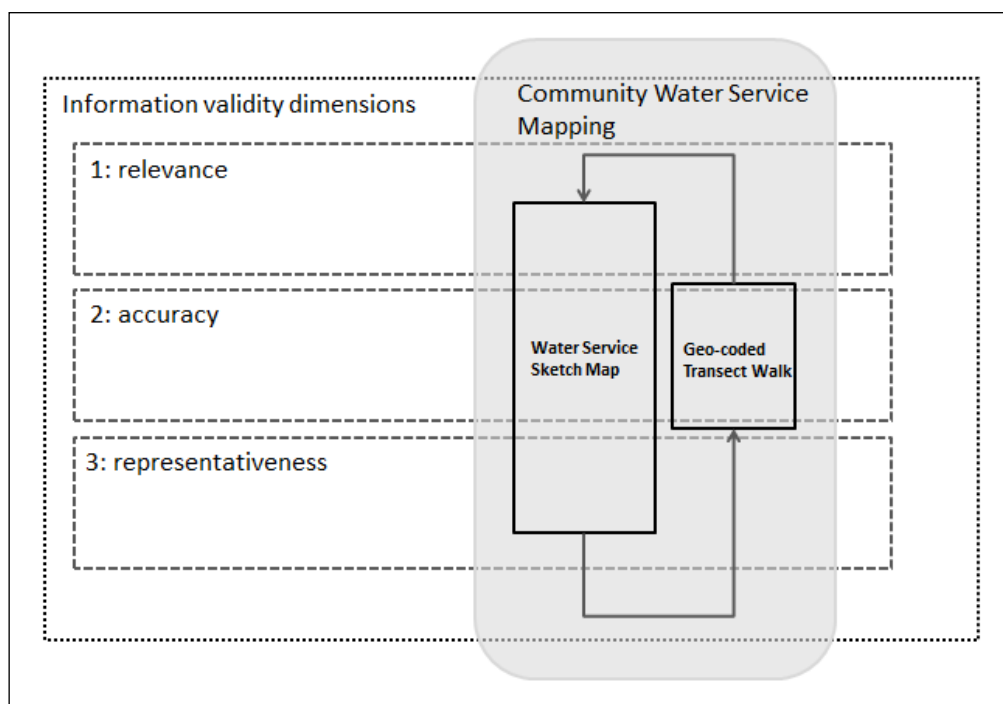

Figure 1: Community Water Service Mapping related to information validity dimensions (Inspired by Vajjala, 2005).

Regarding the validity dimensions, the added value of CWSM realized placeholders by:

- i. Investigating the appropriateness of water service delivery and existing infrastructures *from the perspective of the users*;
- ii. *Documenting the actual functioning of the services and infrastructures and their shortcomings* as experienced by the users while taking into account seasonal variation;
- iii. *Eliciting demographic trends* that according to the users have consequences for services delivery in terms of adequacy of the infrastructures; and
- iv. As much as possible *involving representatives of different groups of users* and varied experience of users in the process.

Despite its practicality and potential, CWSM, as other participatory approaches, faces challenges related to the participation of actors and its implications for the inputs and outputs (McCall, 2004; Amsden and VanWynsberghe, 2005; Chambers, 2006; McCall and Dunn, 2012). More specifically, these challenges deal with information ownership and uses, legitimacy of the empowerment, power relations, and trust between

## EQUITY NON-DISCRIMINATION AND INCLUSION (ENDI)

### Universal Access & the Hard to Reach

the mapping participants. The latter refers to local participants and facilitators (most of the times these are outsiders), which raises issues of institutional and interpersonal trust (Abbot *et al.*, 1998; Rambaldi, 2004; Chambers, 2006; Corbett and Rambaldi, 2009; McCall and Dunn, 2012). Other challenges include unintended and unanticipated consequences, such as heightening tensions and uncertainty in the community (Corbett and Rambaldi, 2009; McCall and Dunn, 2012), which could become a source of conflict between and within communities (Abbot *et al.*, 1998). Besides, this simulation is time consuming, but the output is worth the time invested in it (Amsden and VanWynsberghe, 2005; Chambers, 2006; Corbett and Rambaldi, 2009).

To mitigate the challenges pertaining to the methodology, we paid repeated visits to the village to do the following: familiarisation, collecting demographic data through household survey, building trust and networking with villagers and leaders. Note the survey data are not used in this paper. These visits enabled us to clarify the intention of our research to the community and leaders and inform them on the uses of the results, for them to make informed decision to participate or not.

### Context, aims and activities undertaken

The simulation was conducted by field research in Kidoka village, in Dodoma region in November 2011 through September 2012. The village is located on the Kondoa-Dodoma main road, 65 kilometres from the Kondoa District Council headquarters. Kidoka was selected because it is a good representative of the villages’ water service development and of the management shift from the VWC per se to VWC in collaboration with a private operator. Data collection was done by combining Focal Group Discussion (FGD), participatory sketch mapping, and geocoded transect walk. Through the FGD, mapping participants produced a sketch map with village resources and water services on two joined flip charts. According to Mohamed and Ventura (2000), the geocoded transect walk entails a walk with a hand-held GPS receiver (Garmin 12) to collect positional data (UTM) and write all observations related to mapped items in a field notebook. During the transect walk a digital camera was used to capture location based photographs of the physical condition of the water points and other water infrastructures which is rather common in social media. To double-check our findings and to get leaders’ insights on our study we interviewed the following village leaders: village’s chairperson, council members and executive officer. Nine villagers, six men and three women, participated in the mapping exercises.

The mapping participants were selected based on the following criteria: availability and willingness to participate, involvement in village leadership and experience in local politics, duration of living in the village, gender, age and involvement in water services management. By using the earlier mentioned criteria, a tendency of “community homogenisation” was avoided Craig *et al.*, (2002), the essential parameters of participation of types of participants and their roles in the mapping exercise were included (cf. McCall, 2004; McCall and Dunn, 2012). The composition of the focus group was not meant to represent the village as a whole, the criteria applied to compose it aimed at benefiting from participants’ knowledge and perspectives diversity. Its size had to be kept to the limits amenable for the focus group discussion (cf. Morgan, 1996). Regarding duration of living in the village, six participants were natives and three had migrated to the village at the end of 1990s. The participants had different ages, ranging from 39 to 67. In terms of education, six participants had primary education, two had secondary educations and one had post-secondary education. All nine participants were farmers and were engaged in small-scale business. One of the three women had been a leader in the women’s wing of the current ruling party. The other two women were not involved in any political activity. Three of the six men had been involved in village leadership at different capacities during the 1980s and 1990s.

The mapping exercise was carried out in a classroom at Kidoka primary school. That setting supported discussions among participants and between them and a researcher. The size of the flip charts was sufficiently large to allow interactive mapping. After having completed the sketch map, three mapping participants accompanied the researcher for the transect walk, to record the location of the water distribution points and other on-site attribute data through observation. These participants clarified users-waterpoint interaction to the researchers to avoid misinterpreted observations. During the mapping

## **EQUITY NON-DISCRIMINATION AND INCLUSION (ENDI)**

### **Universal Access & the Hard to Reach**

process, a checklist was used to understand the appropriateness, accessibility and functionality of domestic water service from the users’ perspective.

#### **Main results and lessons learnt**

##### **Kidoka village and context of domestic water service**

In September 2011, the village had 784 households and a population of about 3274 in its four subvillages Mkalama (910 persons), Mkombozi (911), Shule (684) and Kimambo (769). Kidoka has mixture of tribes, mainly the Rangi and Gogo others are Maasai, Sukuma, Barbaig and Bulunge. During the fieldwork, the village leaders reported on the migration of Sukuma and Barbaig pastoralists to the village. The main sources of income are farming and animal husbandry. The current water project was established in 2007, through the Water Sector Development Programme that supports the implementation of the Rural Water Supply and Sanitation Programmes. To establish the project, villagers contributed money and physical labour to meet the criterion of a 5% village’s initial contribution to the capital investment (Giné and Pérez-Foguet, 2008). To plan for this water project, the DWD used the population from the 2002 Census.

Water infrastructures in Kidoka comprise one diesel-pump borehole, seven domestic distribution points, one cattle trough, eight water meters and one pump house. The number of domestic distribution points varies per subvillage; there are two in Mkalama, two in Mkombozi, three in Shule and one in Kimambo. In Shule subvillage, the waterpoint at the village dispensary is not functioning. With regards to functional water points, the average number of users per waterpoint is 467. This implies a shortage of water points because the existing ratio exceeds the national standard (one water point per 250 people) by 217 people.

The water project is managed by the eight members (four men and four women) of the VWC and operated by a private operator. The equal number of men and women in the VWC conforms to the requirement of the 2002 water policy. The VWC members are elected through the village assembly. Each sub-village has two representatives in the VWC, a man and a woman. From the FGDs and interviews with the leaders, the following qualification criteria to become a member of the VWC transpired: being an adult (aged 18 and above), able to read and write, trustworthy, and willing to volunteer. The last two criteria are essential because VWC’s members handle money and are not compensated for their time. The VWC meets once a month and it convenes an extra meeting when there is an emergency such as a breakdown. The current members of the VWC were elected in April 2011 and had not been provided with any training. They manage water services through sharing their experience with the village leaders and other villagers who are willing to contribute their knowledge upon request.

According to the village secondary data on water management and the FGDs, the private operator is contracted for one year through a tender conducted in the village. The village receives technical support on contracting the private operator from the district council mainly the DWD and the District Legal Officer. The private operator is responsible for the ‘minor’ operation costs (minor repairs), paying monthly allowances to the pump attendant and the security guard, and daily allowances to water sellers. Repairs are considered minor when the costs do not exceed TSH 100,000/= (about US\$ 63.98)<sup>32</sup>. The daily allowance is for seven water sellers, six for the domestic distribution points and one at the cattle trough. Each water seller is paid TSH 2,000/= (about US\$ 1.28) per day.

The users’ fee is paid per bucket of 20 litres, at TSH 20/= (US \$ 0.013) and TSH 30/= (about US\$ 0.019) per head of cattle and TSH 10/= (about US\$ 0.006) per head of goat and sheep. As reported by the Village Executive Officer and the VWC treasurer, the private operator is required to pay the village every month with specifications based on seasonality. During the dry season, mainly from July to November, the operator pays the village TSH 800,000/= (about US\$ 511.84) and during the rainy season, from

<sup>32</sup> Based on exchange rate of 1 US Dollar equal to 1,563/= Tanzania Shillings on August 2012. The exchange rate was taken from Indicative Foreign Exchange Market Rates in the Central Bank of Tanzania in <http://www.bot-tz.org/Default.asp>.

## EQUITY NON-DISCRIMINATION AND INCLUSION (ENDI)

### Universal Access & the Hard to Reach

December to June, the operator pays TSH 100,000/= (about US\$ 63.98). The amount of water revenues the operator pays to the village during the dry season exceeds that of the rainy season by TSH 700,000/= (about US\$ 447.86). This is because during the dry season the villagers use more water and people from neighbouring villages with unreliable sources come to Kidoka to get water for domestic uses and livestock. Seasonal fluctuations in the availability of water in rural water schemes are known in other African countries as well, as documented in various studies (Katsi *et al.*, 2007; Arouna and Dabbert, 2010; Aper and Agbehi, 2011). Looking at the terms of payment of the water service provider's contract, we see intersections between the water service, seasonality and the legal context. However, the legal context is not the focus of our research.

### Community mapping process and participants' roles

The CWSM participants provided inputs in the mapping activity on village boundaries, land uses and land cover, public social services, and the location and condition of water distribution points. Before drawing the sketch map, the participants discussed the location of the village in relation to the main road and the compass direction. During that discussion, the participants requested two old village maps to use as references. At first, they requested for the oldest map available in the village which was used when Kidoka was an Ujamaa<sup>33</sup> village in 1970s. It shows the layout of different land parcels and their uses during the Ujamaa era. The second map was made during the village registration exercise in the 1980s by the Ministry of Land, Housing and Settlement Development. This map mainly shows boundaries that demarcate Kidoka and neighbouring villages. The maps referred to are shown in Figure 2 (although not very visible). While referring to the old maps, discussions on historical issues continued among the participants and they affirmed that the old maps helped to place their village in the right location and identify its boundaries with the neighbouring villages. The following fragment of the discussions during and after mapping exercise illustrates this:

*“These two old maps have helped us to find a starting point to draw the sketch map and to place our village in the right location. In fact, the old maps have enabled us to use relatively less time for the mapping exercise because we did not have to figure out so much about the site and boundaries of our village by ourselves.”* (Mapping participants in Kidoka village, 8 August 2012)

The previous quotation affirms Corbett and Rambaldi (2009), findings on ability of community mapping processes to illustrate close relationships between local people and their area, which Parker (2006) refers to as inclusion which supports partly the idea of placeholders.

---

<sup>33</sup> The Ujamaa concept was introduced in 1960s in Tanzania by its first president the late Julius Nyerere as the core focus of social and economic policies for rural development based on collective agriculture and the villagization approach

## EQUITY NON-DISCRIMINATION AND INCLUSION (ENDI)

### Universal Access & the Hard to Reach

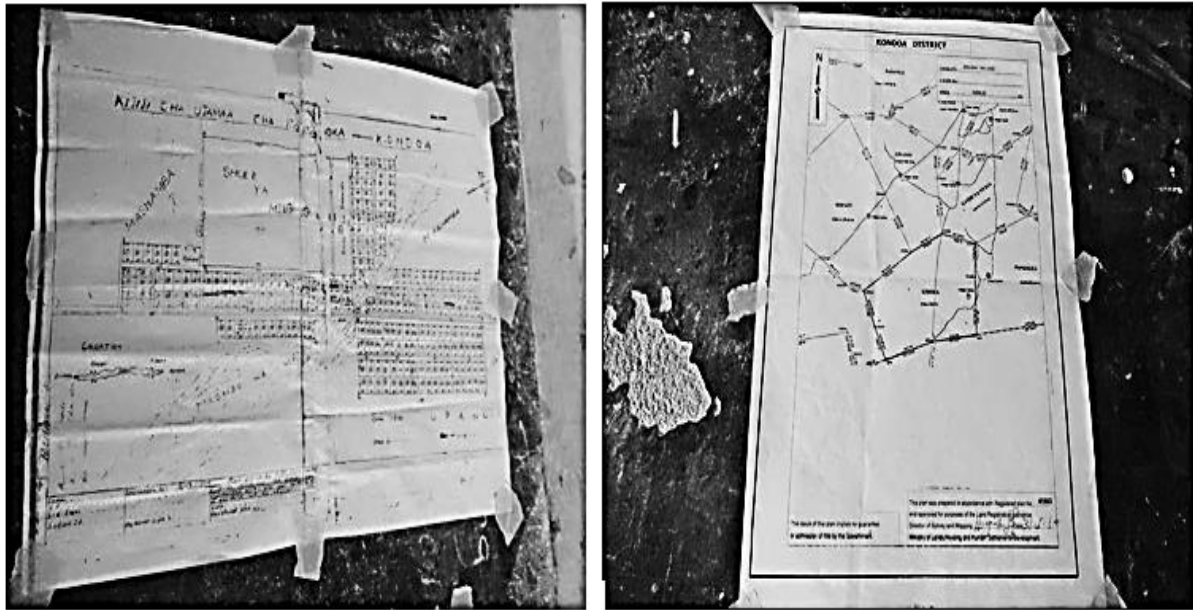

Figure 2: Old maps of Kidoka village used as point of reference during the mapping exercise

The map on the left-hand side was used in Ujamaa village management and that on the right-hand side was used during the village and land registration exercises

In a study carried out in Canada by Johnson (1992) as cited in Corbett and Rambaldi (2009), it is pointed out that local knowledge about the land in participatory mapping is communicated in form of stories. Using the two old maps, the participants started to draw sketch map by beginning with the main road, public institutions at the village centre, and the boundaries between the study area and other villages. When asked why they started with those areas, the participants explained that they always use the main road to travel and to go to the public institutions, such as the village office, primary school, and dispensary. This demonstrates the connection between the mapping participants and important public spaces in their environment. Our findings concur with a study on community mapping in Canada that discovered that “maps are able to capture emotional and other abstract connections experienced by the mapmaker” (Amsden and VanWynsberghe, 2005: 361).

During the mapping exercise, the following patterns were observed: division of roles related to map drawing based on age and sex, interactions among men and women, age variation among group members and turns in speaking per subject matter under discussion. Older men and women from 55 to 67 years dominated the discussion on village boundaries, changing land uses and linking it to the history of the village since its establishment in the 1960s. Two relatively younger men (39 and 45 years) had been chosen by their fellow participants to lead the drawing exercise because they could draw faster than the others. One of the two men had participated in the mapping exercise during the preparation of the 2009 village development plan. There were no major differences between men and women participants in terms of their contribution; though an age pattern could be observed in the discussions on the settlement and its expansion when labelling residential areas. Participants in their early 50s and older who are natives of Kidoka village could say more on the expansion of settlements in Majengo, Songambebe, Mbagostaa and Ndachi neighbourhoods that were previously farmlands. The use of the old maps in our study has enthused retrospective dialogues and enhanced the correctness of the sketch map as shown in Figure 3. This corroborates the findings of Corbett and Rambaldi (2009) that show that local and supplementary sources of spatial and non-spatial information have the potential to improve the accuracy of the final map output.

EQUITY NON-DISCRIMINATION AND INCLUSION (ENDI)

Universal Access & the Hard to Reach

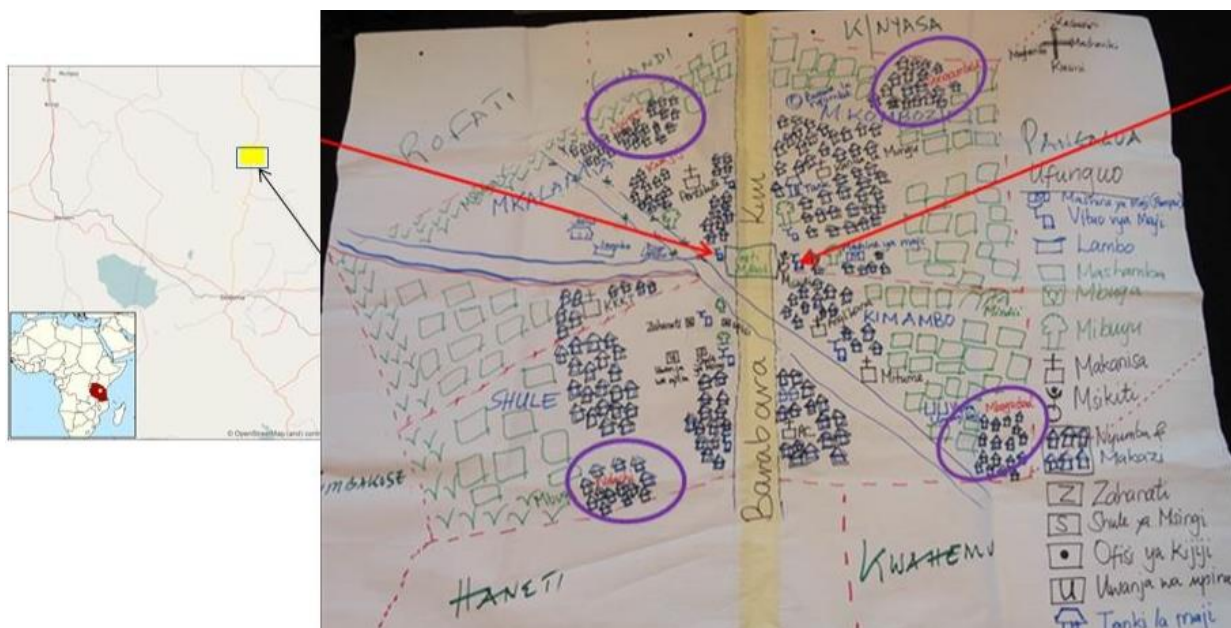

Figure 3: Kidoka village sketch map showing village resources and dynamics in accessibility to domestic water service (arrows point at water points during the rainy season; circles show recent residential areas)

**Geocoded transect walk and inspection of water infrastructures' condition**

Throughout the geocoded transect walk most water infrastructures observed had some defects, such as leakage in a water tank, broken water meters (all 9), cracked and missing water meters' tops (6 out of 9), broken taps (2 out of 8), and an incomplete pump house. Figure 4 shows a set of photographs displaying water infrastructures with defects. The sustainability of the water service in the study area is at jeopardy if immediate and essential measures to repair the infrastructures are not taken.

From the FGD and the interviews with the village's leaders, we discovered that leakage of the water tank and non-functionality of water meters occurred since 2007, just a few months after project inception. Nevertheless, since then the tank and meters have not been repaired. The situation has not been given due attention, because the breakdowns have not (yet) caused acute unavailability of water services in the village. In the discussions while mapping, it transpired that type and prominence of broken-down water infrastructures influence promptness to repair it. The village's chairperson commented: *"The water pump is a very important machine for water availability in the village. Its importance to the availability of water service in this village is almost like that of the heart to human life"* (Village's chairperson, 7 August, 2012). We confirmed from the mapping participants that women play instrumental role in the VWC and 'push' timely repairing of the water pump whenever it collapses. One participant clarified:

*"Truly the women in the water committee are a very big 'push', because when the water pump is broken women members insist that it should be fixed on the same day or very quickly because the broken pump implies no water in the village. Absence of water affects women more because a woman always 'plays with water'. Women will be required to walk longer distances to fetch water from our neighbouring village called Haneti, which is very far by foot"* (Chairperson of the VWC, 8 August 2012).

The above quotation reaffirms that women's roles in provision and collection of domestic water subject them to more difficult experience than men whenever water pump cease to function (Mandara *et al.*, 2013). The leakage of the water tank inhibits its use to its full capacity, which compels the pump attendant to pump water twice or thrice a day. This is inconvenient to the attendant, especially during the farming season. The broken water meters in all eight distribution points pose a challenge to the monitoring of water funds, because neither the VWC nor the operator can keep track of the exactly



## EQUITY NON-DISCRIMINATION AND INCLUSION (ENDI)

### Universal Access & the Hard to Reach

amount of water pumped and the revenue from selling water. Other studies have found that unmetered water supplies lead to heavy losses of revenues to water utilities (Mashauri and Katko, 1993; Chitonge, 2010). Likewise, presence and use of working meters support the estimation of the daily amount of water and generated revenue in the village. When broken-down parts of water taps are unattended for a long time, it may lead to major failure of the water point and ultimately interfere with the sustainability of the whole project. The loose window in the pump house (see picture in Figure 4) jeopardises security of the pump and its frames. From a technical and managerial perspective, neglected, broken and loose infrastructures may deteriorate and become costly to replace.

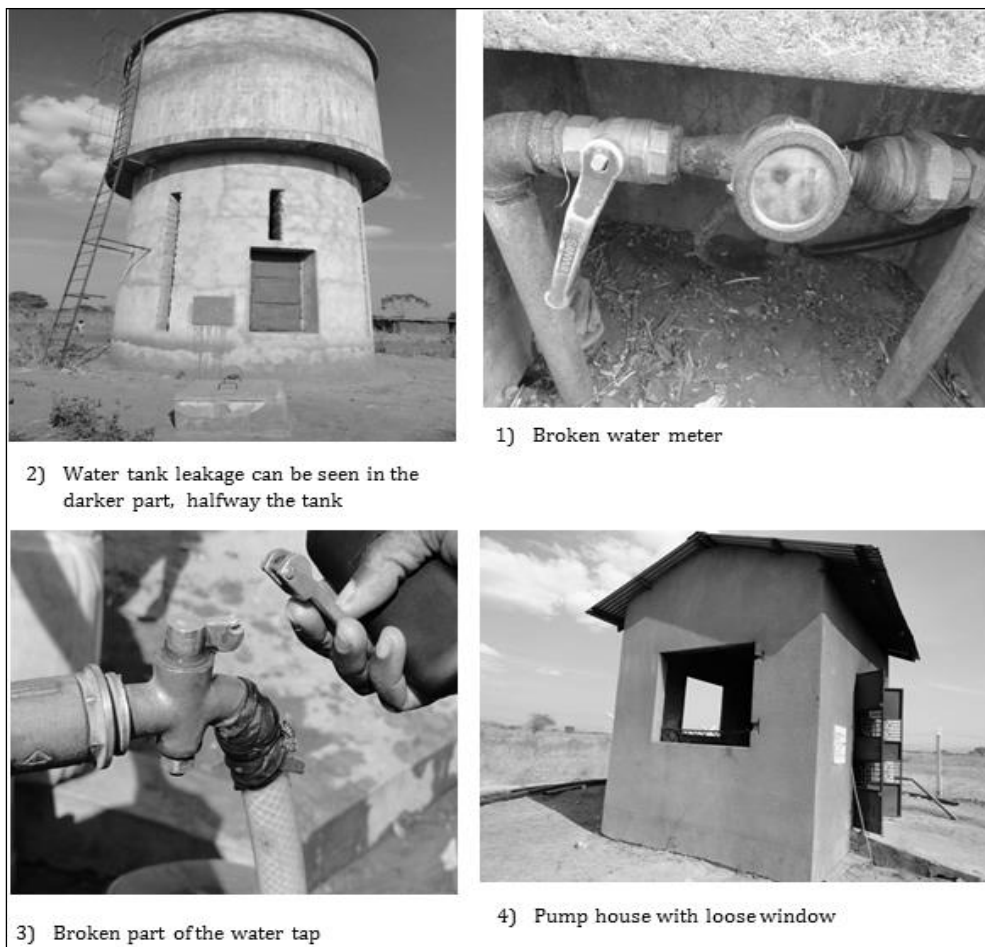

Figure 4 Photographs showing water infrastructures with defects in Kidoka village (photos by C. Mandara during the fieldwork 2011/2012).

The GPS captured locations of water service facilities, like in WPM, gave geometrical correct locations which have been compared with the water services locations in the sketch map. The spatial relations between the water service facilities is in both data sets comparable but the geometrical precision shows doem distortion as indicated in Figure 5.

### Seasonal water services accessibility

A wide range of literature has reported on the relationship between seasonality and the availability of domestic water in the rural areas of developing countries (Rached and Rathgeber, 1996; Thomas, 1998). It is habitually assumed that during rainy seasons the distance to water points in rural areas decreases because rainwater can be harvested by those with iron sheets roofing, gutters and other appropriate gears.

## EQUITY NON-DISCRIMINATION AND INCLUSION (ENDI)

### Universal Access & the Hard to Reach

Moreover, temporary sources such as seasonal rivers develop and ponds are sometimes formed (Katsi *et al.*, 2007; Arouna and Dabbert, 2010; Aper and Agbehi, 2011). In our study we observed that rain water, especially from ponds, was not used for all types of domestic water uses. For details on the latter, (cf. Mandara *et al.*, 2013). Most households continue to collect drinking and cooking water from the public water points. In fact, during the rainy season to some villagers time and distance to the nearest water point increased from 1.5 to 6.4 kilometres because the private operator closes five out of the seven functional distribution points for domestic water. The operator closes the identified water points to reduce administration costs under assumption that rainwater becomes an alternative source of water. When five water points are closed, water users in different subvillages are affected in different ways depending on the number of water points and the location of the ones that continue to be operational. For example, in the subvillages of Mkalama and Mkombozi, one distribution point is closed and one continues to provide services. Shule and Kimambo remain without water services in their subvillages because all water points at Shule are closed down and the only water point in Kimambo is closed as well. This implies that during rainy season the whole village depends on only two distribution points for drinking and cooking water uses: ‘Stendi’ or ‘Kwa Mama Ndee’ in Mkalama sub-village and ‘Msikitini’ at Mkombozi sub-village (indicated by arrows in the sketch map in Figure 3). Referring to Section 5.1 the whole village population of about 3274, depend on two water points (ratio of 1 : 1637) during the rainy season, which by far exceeds the water policy standard. The mapping participants reported that villagers from Mkombozi subvillage, especially those living at Songambebe neighbourhood, have to walk up to about 6.4 kilometres to fetch drinking and cooking water at the ‘Msikitini’ distribution point. In Kimambo subvillage, villagers from Mbagostaa neighbourhood have to go to Mkombozi subvillage, which is about 4.8 kilometres away. These distances substantially exceed the 400 metres that is the national water policy. Moreover, closing the two functional distribution points during rainy season at Shule subvillage where there is village dispensary, causes unnecessary inconveniences to dispensary workers and patients, particularly to women for whom the dispensary also functions as a place to give birth.

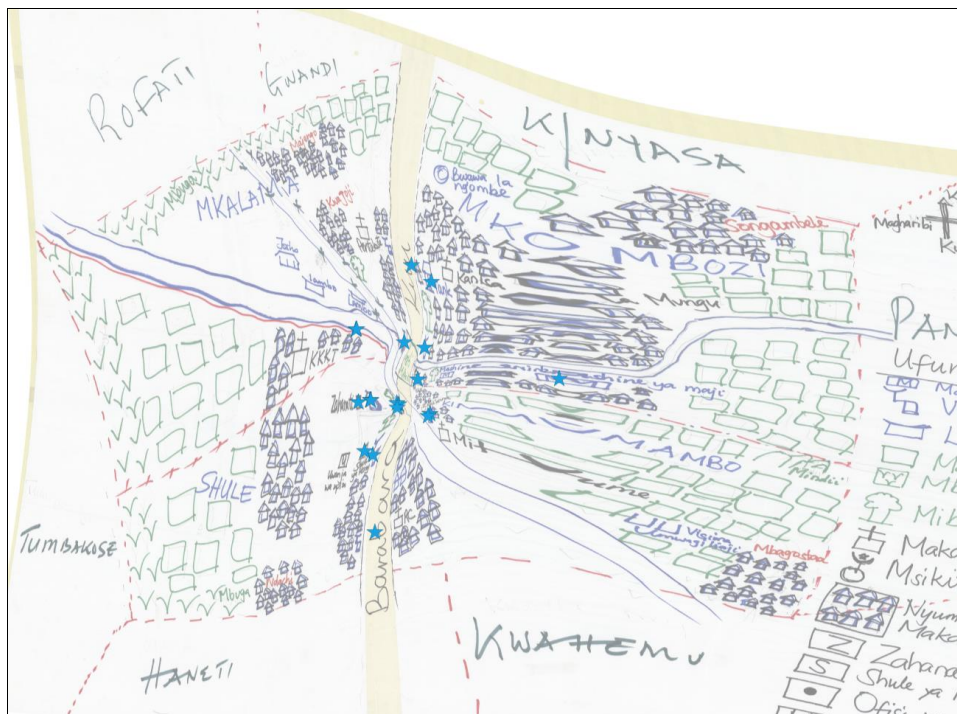

Figure 5 Distortion of Sketch map by using GPS measured locations (blue stars) as geometrical correct reference points

In Figure 3, the four encircled areas are relatively new settlements: Majengo in the northwest, Songambebe the northeast, Mbagostaa in the southeast and Ndachi in the southern part of the village. The land on

## EQUITY NON-DISCRIMINATION AND INCLUSION (ENDI)

### Universal Access & the Hard to Reach

which these settlements are built was farms in 2007 when the water project was implemented. The village leaders disclosed that the settlements are increasingly expanding towards earlier mentioned neighbourhoods; and households in those areas experience water shortages since there are no domestic water points. Furthermore, the villagers residing in the newly developing settlements have to walk from 45 to 90 minutes to get water services from the nearest distribution points, while the national standard for a round trip is 30 minutes (MoWLD *et al.*, 2002; URT, 2010c; 2012). This implies that after implementing village water projects it needs to consider population changes in monitoring and evaluation because population variables change over time. To achieve basic service level in rural areas, the water policy requires year-round supply of 25 litres of potable water per capita per day from a protected water point serving 250 people within 400 meters and spending 30 minutes for a round trip (URT, 2002; 2010c; 2012). Evaluating extent to which these criteria are achieved or not requires timely, valid and up-to-date information on the village's population size and its spatial distribution. Village Executive Officer confirmed that the trend of settlements development continues due to migration of pastoralists from other areas.

*“There is an increase of migrants in our village especially from pastoralist societies like Sukeuma, Barbaig and Maasai. This happens to the extent that the village population records of February this year are expected not to be correct anymore because some of the migrants do not report to the village office upon their arrival. Most of them are settled far away from the village centre, especially in the neighbourhoods of Mbagostaa and Songambebe”* (Village Executive Officer, 8 August 2011).

During the feedback session after the mapping exercise, the participants and village leaders expressed that from their experience as villagers they knew about a need for additional water points in the emerging settlements. Then the mapping participants said that after producing the sketch map it became clearer on the exact neighbourhoods which need additional water points. They further mentioned that, their experience from sketch mapping could become a starting point for the discussion on additional water points with the District Council. The participants' views are expressed as follows:

*“Our participation in the mapping exercise and the map we have produced has enabled us to know the exact areas that need immediate attention, especially Mbagostaa and Songambebe, as there is no any water point in their neighbourhood. The experience can also contribute to the discussion on the expansion of water services in the village”* (Mapping participants, 8 August 2012).

## Conclusions and Recommendations

Simulating social media by a community water service mapping approach to create placeholder information which is of relevance, accurate and is representative offers the following conclusions and recommendations. It has shown an added value in assessing village domestic water coverage. Placeholder is considering actual demographics, location based information and most recent state of domestic water service features. This makes it valuable methodological tool to enhance relevance of information. The interactive setting with the participants from local households, elicits users' knowledge and perspectives on spatial and non-spatial aspects of domestic water services in their locality. In social media this interaction must be secured.

The simulation has shown the intersections between seasonality and the dynamics of the accessibility of water services, as well as intra-village variation among the subvillages in Kidoka village. The mapping exercise in our study was done once; insights on seasonal variability were obtained by additional questioning. Yet, the application of the CWSM approach enabled to reveal changes on the population's spatial distribution from the pattern that existed when the water project started. The situation depicted in the sketch map links spatial and demographic features at village level. This information could allow the relevant higher administrative levels from the district council onwards to prearrange possibilities for expanding installed water service to reflect changes in the population size and distribution. Afterwards, to strategize and prioritise interventions to the neighbourhoods with limited water access.

Accuracy of information shows that numbers, features and locations are far more accurate than any other source may offer. We checked for example Open street Map (OSM, 2016). The topology seems correct but geometrical the placeholder information shows many errors (see Figure 5). Regarding a social media

## EQUITY NON-DISCRIMINATION AND INCLUSION (ENDI)

### Universal Access & the Hard to Reach

application basemaps must be offered which functions as well as baseline information considering administrative boundaries, land use and cover, stream and road patterns, public services ( schools, churches, community houses) and water services. Demographics and water use numbers must be given as well.

Such basemaps represent the main information need to maintain community water services.

Combining by social media application (participatory) sketch mapping with the geocoded transect walk has the potential to better observe, understand and document the actual situation of the village’s water infrastructures. Finally issues considering the amount of observations and who did observe will be critical to derive reliable information. Community processes revolving around these techniques and their triangulation play an important role in validating the information on actual village’s water services coverage and the status of the infrastructures. Social media as such will not address this. There should be a need to organise this within the communities themselves to avoid a Wikipedia – effect .

Our results imply that application of the CWSM methodology yields relevant, accurate and representative information that is important for monitoring and evaluation components of the rural water sector. Therefore, we suggest starting with CWSM in villages with domestic water project knowing that within villages with improved water services there are differences in patterns and dynamics of the accessibility among sub-villages and neighbourhoods. We propose to do this annually. The appropriate time could be at the end of the dry season. During that time water use and breakdowns increase and the villagers will have time to participate because it is not a peak time for farming activities. Such social media approach can be integrated in the preparation of the annual village development plan and be incorporated in the annually scheduled district development plans exercise at the district level. In this study we didn’t look for the most convenient interface because we relied upon traditional techniques like sketching, focus group discussion and some simple technologies like location based mapping inspired by water point mapping. We expect that especially sketch mapping may be a difficult item to offer a usable interface (Jiménez and Pérez-Foguet, 2008; 2010a, 2010b, Welle, 2010; URT, 2011b).

The social media simulation by CWSM as applied in our study can be placed in the category of ethno (carto)graphic methodologies (Wilson, 2009), sharing the theoretical and operational underpinnings of the ethnographic and cartographic research strategies. We add to these the ideas of emerging GIS (Sui, 2015) because we strongly believe in empowering factor of emerging GIS technology that is already available by nowadays social media. Such application of social media will derive placeholders which positively support the community water service coverage.

There is a need to be alert to the risks of up-scaling caused by the multiplicity of local context features, limitations from its interactive nature, and its chances to become politicised. Therefore, when CWSM is introduced as a social media, the facilitators need to adhere to good practices and ethics pertaining to mapping and participatory processes (cf. McCall, 2004; Chambers, 2006; Corbett and Rambaldi, 2009). Application and up-scaling of CWSM requires an answer to the question of the harmonisation of CWSM with monitoring and data collection tools of the officially authorized organisations. An equally relevant issue is that of the relationship between the facilitator of the social media and the local participants in safeguarding the shared placeholders. Local power relations and the dynamics of different positions of the community members involved in such social media-based CWSM processes can cause the results to be contested. These challenges require a thorough and transparent preparation of CWSM that is sensitive to socio-cultural differentiation among the users and can avert it from being politicised.

### Acknowledgements

The authors would like to thank the reviewers of this paper, Aldo Bergsma for cartography and especially our respondents for the valuable information used in this paper and to NUFFIC through the Netherlands Initiative for Capacity Development in Higher Education project (NICHE/TZA/002) for financial support.

### References

## EQUITY NON-DISCRIMINATION AND INCLUSION (ENDI)

### Universal Access & the Hard to Reach

- Abbot, J., Chambers, R., Dunn, C., Harris, T., de Merode, E., Porter, G., Townsend, J. and Weiner, D. (1998). *Participatory GIS: Opportunity or Oxymoron?* PLA Notes, 33: 27-33.
- Amsden, J. and VanWynsberghe, R. (2005). Community mapping as a research tool with youth. *Action Research*, 3 (4): 357-381.
- Aper, J. and Agbehi, S. (2011). The determining factors of rural water supply pattern in Ugbokolo Community, Benue State-Nigeria. *Journal of Sustainable Development*, 4 (2): 225-233.
- Arouna, A. and Dabbert, S. (2010). Determinants of domestic water use by rural households without access to private improved water sources in Benin: A Seemingly Unrelated Tobit Approach. *Water Resources Management*, 24 (7): 1381-1398.
- Chambers, R. (2006). Participatory mapping and geographic information systems: whose map? Who is empowered and who disempowered? Who gains and who loses? *The Electronic Journal of Information Systems in Developing Countries*, 25 (2): 1-11.
- Chitonge, H. (2010). Who is subsidising whom? Water supply cross-subsidisation policy, practice and lessons from Zambia. *The Journal of Modern African Studies*, 48 (4): 599-625.
- Cleaver, F. and Elson, D. (1995). Women and water resources: Continued marginalisation and new policies. *Gatekeeper series No. 49*. London: Sustainable Agriculture Programme of the International Institute for Environment and Development.
- Corbett, J. and Rambaldi, G. (2009). Geographical information technologies, local knowledge and change. In: Cope, M and Elwood, S (Eds.). *Qualitative GIS: A mixed methods approach*. SAGE Publications LTD, London, pp. 74-91.
- Craig, W.J., Harris, T.M. and Weiner, D. (2002). Community Participation and Geographical Information Systems. CRC.
- Elwood, S. (2006). Critical Issues in Participatory GIS: Deconstructions, reconstructions, and new research directions. *Transactions in GIS*, 10 (5): 693-708.
- Elwood, S. and Cope, M. (2009). Introduction: Qualitative GIS: Forging Mixed Methods through Representations, Analytical Innovations and Conceptual Engagements. In: Cope, M. and Elwood, S (Eds.), *Qualitative GIS: A Mixed Methods Approach*. London: SAGE Publications, pp. 1-12.
- Giné, R. and Pérez-Foguet, A. (2008). Sustainability assessment of national rural water supply program in Tanzania. *Natural Resources Forum*, 32 (4): 327-342.
- Glockner, H., Mkanga, M. and Ndezi, T. (2004). Local empowerment through community mapping for water and sanitation in Dar Es Salaam. *Environment and Urbanization*, 16 (1): 185-197.
- Jiménez, A. and Pérez-Foguet, A. (2008). Improving water access indicators in developing countries: A proposal using water point mapping methodology. *Water Science and Technology: Water Supply*, 8 (3): 279-287.
- Jiménez, A. and Pérez-Foguet, A. (2010a). Challenges for water governance in rural water supply: Lessons learned from Tanzania. *International Journal of Water Resources Development*, 26 (2): 235-248.
- Jiménez, A. and Pérez-Foguet, A. (2010b). Building the role of local government authorities towards the achievement of the human right to water in rural Tanzania. *Natural Resources Forum*, 34 (2): 93-105.
- Jiménez, A. and Pérez-Foguet, A. (2011a). The relationship between technology and functionality of rural water points: Evidence from Tanzania. *Water Science and Technology*, 63 (5): 948-955.
- Jiménez, A. and Pérez-Foguet, A. (2011b). Water point mapping for the analysis of rural water supply plans: Case study from Tanzania. *Journal of Water Resources Planning and Management*, 137 (5): 439-447.
- Katsi, L., Siwadi, J., Guzha, E., Makoni, F.S. and Smits, S. (2007). Assessment of factors which affect multiple uses of water sources at household level in rural Zimbabwe - A case study of Marondera, Murehwa and Uzumba Maramba Pfungwe districts. *Physics and Chemistry of the Earth Parts A/B/C* 32, (15): 1157-1166.
- MacDonald, A., Dochartaigh, B.Ó. and Welle, K. (2009). *Mapping for Water Supply and Sanitation in Ethiopia*. RiPPLE Working Paper 11.
- Mandara, C.G., Niehof, A. and van der Horst, H. (2013) Does women's representation in local water management lead to better meeting women's domestic water needs? *International Journal of Social Sciences and Humanity Studies*, 5 (1): 43-62.
- Mashauri, D. and Katko, T. (1993). Water supply development and tariffs in Tanzania: From free water policy towards cost recovery. *Environmental Management*, 17 (1): 31-39.
- McCall, M.K. (2004). *Can Participatory-GIS Strengthen Local-Level Spatial Planning? Suggestions for Better Practice*. A paper presented at the 7<sup>th</sup> International Conference on GIS for Developing Countries (GISDECO 2004), University Teknologi, Johor, Malaysia, 10-12 May 2004.
- McCall, M.K. and Dunn, C.E. (2012). Geo-information tools for participatory spatial planning: Fulfilling the criteria for 'good' governance? *Geoforum*, 43 (1): 81-94.
- Ministry of Water and Livestock Development (MoWLD), WaterAid, Eastern Africa Statistical Training Centre and National Bureau of Statistics. (2002). *Water and Sanitation in Tanzania: Poverty Monitoring for the Sector Using National Surveys*. Dar Es Salaam: MoWLD, WaterAid, EASTC and NBS.
- Mohamed, M.A. and Ventura, S.J. (2000). Use of Geomatics for Mapping and Documenting Indigenous Tenure Systems. *Society & Natural Resources*, 13 (3): 223-236.
- Morgan, D.L. (1996). Focus groups. *Annual Review of Sociology*, 22: 129-152.
- Open Street Map (2016). <https://www.openstreetmap.org/search?query=dodoma%20tanzania#map=14/-5.4898/35.8581>
- Parker, B. (2006). Constructing community through maps? Power and praxis in community mapping. *The Professional Geographer*, 58 (4): 470-484.
- SNV-Dar Es Salaam-TZ. (2010). *Water Point Mapping: The Experience of SNV Tanzania*. Dar Es Salaam, Tanzania. SNV, Tanzania.
- Stoupy, O. and Sudgen, S. (2003). *Halving the number of people without access to safe water by 2015—A Malawian perspective*. Part 2: New indicators for the millennium development goal. WaterAid, London.
- Sui, D. (2015). Emerging GIS themes and the six senses of the new mind: is GIS becoming a liberation technology?, *Annals of GIS*, 21 (1), 1-13.
- Taylor, B. (2009a). Addressing the sustainability crisis: Lessons from research on managing rural water projects WaterAid Tanzania. Online source: <http://www.wateraid.org/~media/Publications/sustainability-crisis-rural-water-management-tanzania.pdf>. (Accessed on 7/11/2012).

## EQUITY NON-DISCRIMINATION AND INCLUSION (ENDI)

### Universal Access & the Hard to Reach

- Taylor, B. (2009b). Management for Sustainability: Practical lessons from three studies on the management of rural water supply schemes, WaterAid Tanzania. Online Source:  
<http://www.wateraid.org/~media/Publications/practical-lessons-rural-water-supply-management.pdf>. (Accessed on 7/11/2012).
- Thomas, T. (1998). Domestic water supply using rainwater harvesting. *Building Research & Information*, 26 (2): 94-101.
- URT. (2002). *National Water Policy*. Dar Es Salaam: Ministry of Water and Livestock Development.
- URT. (2008a). *National Water Sector Development Strategy 2006-2015*. Dar Es Salaam: Ministry of Water and Irrigation.
- URT. (2009a). *Household Budget Survey 2007-Tanzania Mainland*. Dar Es Salaam: National Bureau of Statistics.
- URT. (2010a). *National Strategy for Growth and Reduction of Poverty II- (NSGRP II)*. Dar Es Salaam: Ministry of Finance and Economic Affairs.
- URT. (2010b). *Water Sector Status Report*. Dar Es Salaam: Ministry of Water and Irrigation.
- URT. (2010c). *Tanzania Demographic and Health Survey: Key Findings*. Maryland: National Bureau of Statistics and ICF Macro.
- URT. (2011a). *MKUKUTA Annual Implementation Report 2010/II: "Delivering on Commitments"*. Dar Es Salaam: Ministry of Finance.
- URT. (2011b). *Water Sector Status Report 2011: With a Summary of Water Sector Progress since 2007*. Dar Es Salaam: Ministry of Water.
- URT. (2012). *Poverty and Human Development Report 2011*. Dar Es Salaam: Research and Analysis Working Group, MKUKUTA Monitoring System, Ministry of Finance.
- Vajjhala, S.P. (2005). *Integrating GIS and participatory mapping in community development planning*. A paper presented at the ESRI International Users Conference, Sustainable Development and Humanitarian Affairs Track. San Diego, CA, 25-29 July, 2005.
- Vervoort, J.M. ; Kok, K. ; Beers, P.J. ; Lammeren, R.J.A. van; Janssen, R. (2012). Combining analytic and experiential communication in participatory scenario development, *Landscape and Urban Planning*, 107 (3): 203 - 213.
- Waal, R.M. de; Kempenaar, J. ; Lammeren, R.J.A. van; Stremke, S. (2013). Application of social media in a regional design competition: a case study in the Netherlands In: *Proceedings of the 14th International Conference on Information Technologies in Landscape Architecture*, DLA Conference 2013. - Anhalt : Wichmann Verlag, 14th DLA Conference 2013, Bernburg, Germany, 2013-06-06/2013-06-08 - 186 – 200.
- Welle, K. (2005). *WaterAid Learning for Advocacy and Good Practice: Water Point Mapping in Malawi and Tanzania*. WaterAid, Tanzania. Online source:  
[http://www.wateraid.org/documents/plugin\\_documents/malawi\\_tanzania.pdf](http://www.wateraid.org/documents/plugin_documents/malawi_tanzania.pdf). (Accessed on 20/10/2013).
- Welle, K. (2010). *Water Point Mapping: A Tool for Increasing Transparency and Accountability*. Paper presented at the IRC symposium Pumps, Pipes and Promises: Costs, Finances and Accountability for Sustainable WASH Services. The Hague, the Netherlands, 16-18 November 2010.
- Wilson, M.W. (2009). Towards a Genealogy of Qualitative GIS. In: Cope, M. and Elwood, S. (Eds.), *Qualitative GIS: A Mixed Methods Approach*. London: SAGE Publications, pp. 156-170.

EQUITY NON-DISCRIMINATION AND INCLUSION (ENDI)

Universal Access & the Hard to Reach

# Supporting sustainable WASH services in difficult operating environments: A case study from Nicaragua

Type: Long Paper (up to 6,000 words)

**Authors** *Joshua Briemberg* (Country Director, WaterAid Nicaragua, [JoshuaBriemberg@wateraid.org](mailto:JoshuaBriemberg@wateraid.org), +505 8837.0770), *Ryan Schweitzer* (Aguaconsult, UK), and *Vincent Casey* (WaterAid America) [vincentcasey@wateraid.org](mailto:vincentcasey@wateraid.org)

## Abstract/Summary

If WASH services are to deliver continuous benefits to users they must be supported by strong, responsive, permanent in-country institutions. Strengthening permanent institutions is very challenging in difficult operating environments and requires approaches that work beyond the delivery of taps and toilets alone. This document is aimed at WASH practitioners and policy-makers developing management and support processes that ensure service sustainability. It seeks to share WaterAid Nicaragua's experiences of reinforcing sustainable WASH service provision in an environment characterised by weak and under-resourced institutions, exposure to disasters, and a history of conflict and political polarisation. To achieve this objective, WaterAid Nicaragua is strengthening the service delivery, strategic planning, financing, monitoring, coordination, accountability mechanisms and post-implementation support functions of permanent institutions. Barriers to sustainability and WaterAid's approaches to addressing them are described in the proceeding sections.

## Introduction

Nicaragua's income status, as defined by the World Bank, was considered lower-middle income in 2015, however, its gross national income per capita, \$1,870, is significantly lower than the regional average of \$9,095 (World Bank, 2014). The Human Development Index, a composite score based on health and education indicators, has Nicaragua in the bottom third worldwide (125th out of 180 countries) with a score of 0.631 (UNDP, 2015). Between 2009 and 2014 general poverty in Nicaragua dropped 14% and extreme poverty dropped 6%, from 14.6 to 8.3% (World Bank, 2014). Despite these gains in poverty reduction, inequality is still a significant concern and poverty is most prevalent in the indigenous regions along the Caribbean Coast, which is where WaterAid operates.

In Nicaragua 87% of the population has access to an improved water source – 99% and 69% in urban and rural areas respectively (WHO/UNICEF, 2015). With regard to sanitation, 68% have access nationwide, with 76% coverage in urban areas and only 56% in rural areas. An estimated 420,000 people practise open defecation, with the vast majority of these individuals living in rural areas (WHO/UNICEF, 2015). In the autonomous regions where WaterAid works, conditions are drastically different; only 18% of the population has sustained access to safe water, and 20% has access to adequate sanitation. These low rates are exacerbated by poor service functionality (up to 80% of water supply services are estimated to be non-functional at any one time) (Herrera et al, 2014).

## Where WaterAid works

Nicaragua is divided into three regions, Pacific, Central-North and Caribbean, which are subdivided into 17 administrative departments or regions. WaterAid programmes are focused in the two Caribbean autonomous regions, Región Autónoma del Caribe Norte (RACN) and the Región Autónoma del Caribe Sur (RACS), which make up approximately 50% of Nicaragua's total land area. Only 15% of the country's

## **EQUITY NON-DISCRIMINATION AND INCLUSION (ENDI)**

### **Universal Access & the Hard to Reach**

total population live in this region, and nearly three quarters of the people live in severe poverty as defined nationally: \$1.73 per day (World Bank, 2014).

The challenges facing RACN and RACS are many. Limited transportation and other civil infrastructure means that the cost of moving goods and providing public services is high. A low population density (11 people per square kilometre) means that per capita costs are high for public services. Together these conditions mean that economies of scale are difficult to achieve, and the availability of goods and materials is limited, making it difficult to establish viable supply chains. Economic challenges are compounded by the area’s vulnerability to extreme weather events such as hurricanes and tropical storms. Staff appointments within local institutions can be politically driven, meaning capacities can be lost when there are changes in leadership. Conflicts over land ownership frequently erupt, impacting on access to villages and social cohesion. Geographic isolation and administrative segregation means that these regions are often politically disconnected from the Pacific regions, and therefore are not prioritised.

Despite these challenges, there are many opportunities in the Caribbean regions. There is great social and cultural diversity in the indigenous Miskitu, Mayangna and Ramas peoples, as well as the ethnic Creole, Mestizos and Garifunas, and the community social networks are strong with an ingrained sense of equity and inclusivity. There is also an abundance of natural resources and local resources for construction, and the accompanying knowledge on appropriate construction practices.

### **WaterAid Nicaragua country programme**

Programme started in 2012 and since then has focused its work in 20 villages and two peri-urban towns in the RACN. The programme has grown from two people with an annual budget of \$133,000, to a staff of 18 and an operating budget of \$750,000. It has established strong partnerships with local organisations, government, private sector and international non-government organisations.

Programme achievements 2012–2014:

- 18 schools with improved WASH services, 7,323 people with improved water supplies and 5,224 people with improved sanitation.
- Capacity development of local governments in areas of planning and coordination.
- Development of innovative approaches to provide water and sanitation services to the poorest in peri-urban areas as well as remote, rural indigenous populations.

WaterAid has a new strategy in 2016 with the following key objectives:

1. Continue programmatic approach, which combines ‘traditional’ implementation at the community level with strategic support and activities at the sector level (e.g. sector knowledge development, coordination groups and technical working groups).
2. Focus on a municipality-wide approach extending work into new areas of the RACN.
3. Continue to focus on indigenous communities and marginalised groups, with a strong emphasis on community participation and empowerment.
4. Prioritisation of sanitation and hygiene, while integrating maternal and child health into these activities.

### **What others are doing in and around the autonomous regions**

Swiss Development Corporation (SDC) has supported WASH related work in the northern autonomous region but more recently has focused on the non-indigenous and less remote municipalities of Siuna, Mulukuku, Waslala and Bonanza. During the period 2002 – 2006 SDC supported work in the municipalities of Puerto Cabezas, Rosita, Siuna, Mulukuku and Bonanza in partnership with Save the Children. The Nicaragua AGUASAN program has now closed leaving only the Regional Aguasan Program.



## EQUITY NON-DISCRIMINATION AND INCLUSION (ENDI)

### Universal Access & the Hard to Reach

Development Partners working in the autonomous regions include:

1. Health Poverty Action (HPA) – a UK-based organization supporting health programs
2. Plan – focused on child rights based programming
3. GVC – an Italian NGO focusing mainly on climate change adaptation
4. Welthungerhilfe - a German NGO with a food security program (that has now closed)
5. Horizonte 3000 – an Austrian organization working specifically with the indigenous Mayangna communities in the BOSAWAS Biosphere Reserve

WaterAid has partnered in varying ways with each of these organizations (except Horizonte 3000) and is currently partnered with HPA to integrate WASH into maternal and early child health programmes.

### Institutional arrangements

Nicaragua is characterised by a complex institutional configuration with a mix of different government agencies having overlapping, conflicting and/or unfulfilled roles and responsibilities for service provision. The picture is particularly complicated in the autonomous regions, where both donor and treasury funds are channelled alternatively via a national agency (Nuevo FISE), the regional government and indigenous territorial governments, who then have the remit to implement locally alongside municipalities. Whilst municipalities have legal responsibility for providing water and sanitation services, in practice this mandate is often not fulfilled.

**TABLE 1: Main Nicaraguan institutions involved in water and sanitation sector and their main responsibilities.**

Main entity	Roles and responsibilities
Nicaraguan State Enterprise for Drinking Water and Sewerage (ENACAL)	Public utility serving urban water users including nearly 100% of the population in Managua. ENACAL is also responsible for planning.
Ministry of Environment and Natural Resources (MARENA)	Responsible for environmental policies and watershed management and climate change adaptation and mitigation initiatives.
National Water Authority (ANA)	Decentralised executive body for water resource issues, with its own legal status and administrative and financial autonomy. Provides concessions for water resource use. Develops the National Plan of Water Resources that serves as the basis for basin plans.
National Commission for Water Resources (CNRH)	Mandate for sector planning, as well as acting as a participatory forum with advisory and coordination functions, and oversees work of National Water Authority (ANA).
Nicaraguan Institute of Water and Sanitation Systems (INAA)	Regulator that develops norms and standards for water and sanitation service providers (public, private, civil society, etc.), provides concessions for service providers, and collects and processes complaints by customers.
Emergency Social Investment Fund Programme (FISE) Under the presidency	Aims to facilitate access to basic universal services for impoverished communities and vulnerable groups, and to promote social protection. It is responsible for water, sanitation and hygiene sector in rural areas. Authority for rural WASH sector was transferred from ENACAL to FISE by Presidential decree in 2004.
Municipal government	Municipalities are responsible for ensuring the provision of water and sanitation services in Nicaragua, however, very few are directly involved in service provision.
Water Committees (CAPS)	Legally recognised community groups responsible for managing

## **EQUITY NON-DISCRIMINATION AND INCLUSION (ENDI)**

### **Universal Access & the Hard to Reach**

<b>Main entity</b>	<b>Roles and responsibilities</b>
	and maintaining rural water supply services for communities with fewer than 500 people in accordance with 2010 law.

### **Sector finance**

The government of Nicaragua has a plan to invest approximately \$2 billion in water and sanitation during the period covered by the Sustainable Development Goals (up to 2030). Under this programme, called PISAH – Programa Integral Sectorial de Agua y Saneamiento Humano de Nicaragua, about \$70 million per year is expected to be invested in the rural sector starting in 2016. This is an increase of over 300% from the rates of 1991–2013. However, a gap still exists.

A significant percentage of the investments in the water and sanitation sector are financed by foreign donors or multilateral development banks. A prime example is the programme financed by the Spanish Development Cooperation (AECID) and managed by the Inter-American Development Bank (or Banco Interamericano de Desarrollo, BID), which is dedicating \$343.3 million to improve water and sanitation services in 19 secondary cities. This includes a \$58 million water project in Bilwi in RACN (AECID, 2016).

It is common for communities to contribute between 10–15% of the total capital costs. However, there is no clear policy stipulating the required contributions that communities should make and therefore this percentage represents what has become the accepted standard. Municipal governments are also expected to contribute up to 10% of the total capital cost, in accordance with their allocation of 7% of treasury fund transfers to the WASH sector (and another 7% to education and 7% to health). The private sector does not play a significant role in WASH sector investment.

### **Sector challenges**

The challenges facing the WASH sector in Nicaragua are varied.

- Complicated legal framework, largely as a result of an aborted privatisation process resulting in fragmentation of roles and responsibilities among multiple institutions.
- In the indigenous territories there is generally a low capacity of both local government and local organisations to plan for, construct, operate and maintain water and sanitation services.
- This low capacity is complicated by a lack of clarity over roles and responsibilities between central government institutions (e.g. FISE, ENACAL), the autonomous regional governments and the municipal governments. This results in parallel structures and has prevented the decentralization of power to the local level.
- Lack of clear strategies to enact the priorities expressed in policy.
- Limited awareness of sector-specific policies and plans at autonomous Caribbean region and municipal level.
- Deficit in spending on water supply and sanitation, limited resources at the municipal level and insufficient funding provided by central government.
- Limited understanding of the life-cycle costs of water and sanitation services, meaning planning does not take into account the true financing needed to ensure sustainability. The water resource context of the Pacific and Central-Northern regions is totally distinct from the Caribbean region where low-lying surface water predominates and precipitation rates are high, demanding different technical approaches to those that are promoted at the national level.

### **Description of the Case Study – Approach or technology**

## **EQUITY NON-DISCRIMINATION AND INCLUSION (ENDI)**

### **Universal Access & the Hard to Reach**

WaterAid’s approach to development seeks to address the issues of service sustainability by strengthening service delivery in the communities where it works, whilst simultaneously working to strengthen the strategic planning, financing, monitoring, coordination, accountability mechanisms and post-implementation support functions of permanent institutions. This mixed approach combines a focus on best-practice service implementation with up-stream system strengthening support to permanent institutions. The approach is in alignment with the principles that WaterAid promotes globally through the Agenda for Change initiative.

In Nicaragua WaterAid draws on an understanding of social and cultural practices together with knowledge of governance systems in the autonomous indigenous territories. The community is placed at the forefront of interventions to encourage ownership and demand for services. WA Nicaragua complements this participatory approach with engagement of local government and the local private sector to create the conditions for successful delivery of services in the communities, as well as competent oversight, support and regulation of the service providers. This approach challenges WA Nicaragua staff, as well as its local partners, to think beyond taps and toilets to provide solutions that move beyond those that are “one-size-fits-all”. The aim is to promote solutions that are specific to the context and therefore ensure a greater potential for sustainability.

WaterAid’s work in the municipalities is complemented by work to support sector development at the regional and national level. An example is WA Nicaragua’s leadership role in national coordination forums. WA Nicaragua currently chairs the Coordination Committee for the Nicaraguan WASH Network or RASNIC (the Spanish acronym), which is a multi-stakeholder forum composed of government institutions, aid agencies, international NGOs, civil society organisations and universities active in WASH. RASNIC is a knowledge exchange platform. The motive behind this work is the understanding that strong, accountable, responsive and well-coordinated institutions must exist at all levels if their services are to be sustained.

The following case study is divided into three sections which describe how WA Nicaragua is: 1) strengthening the capacities of municipal government service authorities as well as the systems at the national level; 2) strengthening the service providers and the local private sector; and 3) spearheading efforts to educate and empower communities.

### **Strengthening government**

#### **Commitment to support local government**

WA Nicaragua’s initial engagement with a municipality is based on the demand expressed by the municipality through mesas de agua or roundtable discussions which convene various WASH stakeholders at the municipal level. These meetings are used as an opportunity to make sure that WA Nicaragua expertise is in line with the needs of the municipality. In the autonomous regions of the Caribbean there is a significant need for capacity building of local government, and with very few municipal staff and no designated budget for operations the challenge is even greater. The problem is compounded by staff changes which frequently occur following changes in political leadership. However, WA Nicaragua has worked to establish ongoing cooperative agreements outlining its commitment to strengthening the capacities of the municipality and the municipality’s commitment to carrying out its roles and responsibilities to ensure sustainable WASH service delivery. Currently WA Nicaragua and/or its local partners has cooperative agreements with four municipalities, and is providing training and support on a continuous basis.

WA Nicaragua has worked to build the capacity of WASH units within each municipality where it works. These units are an operational arm of the municipality, and are supposed to provide on-the-ground technical assistance and oversight of water systems managed by the community user associations (CAPS). However, capacity for providing support is very limited, both from an operational budget perspective and from a human resource (i.e. skills and knowledge) perspective. Currently WA Nicaragua is organising general training for members of the municipal WASH units on quality assurance and quality control of

## **EQUITY NON-DISCRIMINATION AND INCLUSION (ENDI)**

### **Universal Access & the Hard to Reach**

construction, as well as more specific technical issues, such as how to install, operate and monitor in-line chlorinators.

WA Nicaragua has the goal of improving the administrative capacity of the municipality for planning and budgeting, with the hope that in the mid-term each of the four municipalities where WA Nicaragua works will develop a clear vision and strategy for meeting the Sustainable Development Goals of universal and sustainable access to water and sanitation service by 2030. Practically speaking this would require the development of a multi-year strategic development plan, however, the capacity of the local government staff for public financial management (PFM) is very low. Targeted training on how to develop such plans may be possible in the coming years, however, WA Nicaragua’s current work involves building the administrative capacities within the municipality from the community upwards, through participatory governance, involving the training of municipal government staff and community leaders in participatory needs assessment and community mapping. Together, the community leaders and local government representatives facilitate an assessment with the community, identifying priorities and opportunities and producing a costed action plan that could include water supply and sanitation infrastructure, behaviour change or hygiene promotion.

WA Nicaragua facilitates this process and the outputs are used as an entry point to building the capacity of the municipality for planning and budgeting (i.e. development of its annual operating plans).

### **Supporting the national enabling environment**

WaterAid is relatively new in the WASH sector in Nicaragua, therefore, unlike other country programmes it hasn’t been as directly active in sector advocacy. In the most recent operational plan WA Nicaragua will be shifting resources to increase the amount of advocacy work in their portfolio that targets sector-level issues. Despite only four years in country, WaterAid has cultivated valuable knowledge through the experience of working with local government and implementing in the communities in the autonomous regions. Much of this knowledge has been gained from piloting and refining new approaches and innovative technologies.

Given the unique social, cultural and geographic context of the Caribbean coast it is not possible to apply a template solution. Therefore many of the approaches that are used elsewhere in Nicaragua are not compatible. WA Nicaragua has been developing new approaches through its participatory approach with municipal government, community leaders, and the private sector. These are described further in the following sections.

Through this work WA Nicaragua has been able to identify challenges and gaps which are systemic and which, therefore, need to be addressed through targeted efforts at the sector level. For example as coordinator of RASNIC, the national WASH Network, WA Nicaragua has been advocating for the importance of using water security and climate change adaptation frameworks to plan for services, while expanding efforts to strengthen the role of municipal government staff and community water associations to address issues of climate change and water security. In addition, WA Nicaragua has contributed to the sector through targeted studies commissioned in partnership with other development partners, including a market study on the effective demand for credit for WASH products and a study of the perception and use of multiple water points. WA Nicaragua has also documented and shared experiences of technology introduction in the Caribbean region, including its successes and failures using the WASHTech Technology Applicability Framework (TAF).

### **Strengthening service providers**

#### **Encouraging entrepreneurship and stimulation of innovation**

WA Nicaragua stimulates the private sector by cultivating the spirit of entrepreneurship within the peri-urban areas and communities where it works, through its WASH Market Development Project. It does this through gender-inclusive vocational training for community WASH technicians and hygiene

## **EQUITY NON-DISCRIMINATION AND INCLUSION (ENDI)**

### **Universal Access & the Hard to Reach**

promoters. In the town of Bilwi in RACN, WA Nicaragua has worked in collaboration with UNICEF, the regional government and the National Technical Training Institute to carry out training that targets at-risk youth. This training provides participants with skills that have enabled them to become service providers in the water and sanitation sector. Community leaders from religious, academic and government institutions identify unemployed youths who have dropped out of school and are living in high-risk environments to participate in technical and vocational training.

The training consists of 240 hours of coursework (i.e. six weeks full-time) and is broken down into 80% technical skills, 10% life skills and 10% basic business skills (e.g. developing a business plan and budgeting). To date 54 individuals have been trained in two cycles (34 and 20 individuals respectively). A third cycle with 30 participants is currently underway. The government is also taking a role, with the regional government, through the educational secretariat and the regional WASH unit, assisting in recruiting participants and coordinating efforts, and it is also directly funding the costs of the participants. WA Nicaragua is providing guidance on technical aspects and is trying to develop individual curricula for technicians and entrepreneurs.

This programme has been gauged a success, with 16 of the 54 programme graduates active on a regular basis, providing their WASH services in the communities and peri-urban areas. Nearly half of the graduates are women, and one is now pursuing a civil engineering degree at the regional university. The programme will yield significant results in the long-term by increasing the pool of professional staff and semi-professional, skilled labour. These individuals will not only be capable of providing WASH services as private entrepreneurs, they will also feed the pool of potential applicants to staff positions at ENACAL when the municipal water and sanitation system are put in place or within the municipal and regional WASH units.

### **Support to self-supply initiatives**

To support self-supply initiatives and local service providers, WA Nicaragua is exploring the possibility of creating a national research centre, similar to centres in Tanzania that promote Simple, Market-based, Affordable and Repairable Technologies (SMART) . This centre could be used to train technicians and establish a formal licensing process for WASH technicians and service providers in the country. It could also be used to train local government on the appropriate steps for construction observation.

Nicaragua has a long history of success with regards to self-supply, with the rope pump being successfully introduced in the 1980s and the clay pot, point-of-use filter being launched in the 1990s. WA Nicaragua has successfully promoted the rope pump in RACN and RACS along with other alternative technologies in rural water supply. These include:

- Ferro-cement water storage tanks for use in rooftop rainwater harvesting
- Manual drilling technologies for developing boreholes
- Improved existing hand-dug wells
- Introduction of the EMAS Pump (originally developed in Bolivia)
- Renewable energy powered (photovoltaic-based and hydraulic ram pumps) communal systems with gravity-flow distribution

To guide the selection and introduction of these alternative technologies, WA Nicaragua has utilised an assessment tool called the Technology Applicability Framework (TAF). TAF is a decision-making tool on the applicability and potential for sustainability of the use of a specific WASH technology in a specific context. It is composed of two components, the screening and the assessment, which give a view of the likely sustainability, uptake and scalability of new technologies considering the contextual conditions needed for their successful introduction. The methodology provides guidance for the analysis and design of a technology introduction process for three different investment models .

## **EQUITY NON-DISCRIMINATION AND INCLUSION (ENDI)**

### **Universal Access & the Hard to Reach**

WA Nicaragua has focused on generating the markets for these alternative rural and peri-urban water supply products and services. To maximise the success of this process, WA Nicaragua has worked to increase the ability of households to pay for these technologies by investing in microcredit services within the areas where it works.

### **Strengthening communities and service financing mechanisms**

#### **Empowerment through microcredit**

Globally, there has been demonstrated success using microfinance for achieving gains in access to water supply and sanitation services. In Nicaragua WaterAid has been approaching microfinance with the outlook that it can empower individuals or groups of individuals in many different ways and in relation to various basic services. For example, in relation to rural water supply it can help entrepreneurs to establish their micro-enterprises as service providers (e.g. repairing rope pumps or emptying on-site septic tanks for final disposal of faecal sludge). Microfinance can also help households to improve their water service levels (e.g. by helping them finance the purchase of a manually drilled well, ferro-cement rainwater harvesting tank or pour flush toilet with on-site treatment) or it can enable communities to introduce metering and on-line chlorination into their systems and improve accountability and payment levels.

WA Nicaragua commissioned a study in RACN to better understand the supply and demand of micro finance products that could be used by individuals, households or communities. This study identified segments of the population that could be potential consumers for tailored financial products (i.e. products with terms and conditions to meet their willingness and ability to pay). The study concluded that there is a market of over \$4 million for financial products in three small towns in the region, however, this demand was more than ten times greater than the supply (i.e. total value of finance available). As a result of these findings, WA Nicaragua has focused its efforts upstream to try and improve the finance available to the microfinance institutions (MFIs) and the delivery capacity of local service providers. WA Nicaragua also worked with participants of the vocational and entrepreneurial training from the private sector to help business people to understand WASH markets, and efficiently and effectively utilise their loans. This knowledge will allow individual entrepreneurs to develop customised services to meet the existing needs of people in these communities.

WA Nicaragua worked with the Inter-American Development Bank (IDB) to obtain seed funding for its local MFI partner Pana Pana, while leveraging greater access to funds from Kiva, a global microfinance institution that provides interest-free loans to its clients. WA Nicaragua then provides technical assistance to the WASH entrepreneurs to ensure that the service delivered is of high quality.

#### **Linking water supply and sanitation**

WA Nicaragua has been able to stimulate a drastic increase in sanitation coverage levels in the areas where it works, particularly in those communities where water supplies have already been established as part of the community action plan. WA Nicaragua’s approach to sanitation is grounded in an aspirational approach that seeks to educate, empower and motivate those communities with greatest need, but also where the conditions for success exist. Gains in coverage levels of up to 100%, like those in the community of Truhlaya, can be attributed to a number of factors, which include:

- 1) A positive triggering approach leverages the sentiments of cleanliness as a sign of status. At the same time the approach prioritises those who derive the greatest benefit from direct access to a toilet from within the house, such as elderly and handicapped people, and pregnant women. The vision of this approach is that a pit latrine is no longer viewed as a symbol of progress, but instead, higher service levels are the more socially desired outcome.
- 2) Fit for purpose sanitation design. WA Nicaragua has developed an innovative design for a pour flush latrine combining local materials, for an elevated superstructure, with conventional materials for the toilet seat (porcelain), plumbing, septic tank and drain field.

## EQUITY NON-DISCRIMINATION AND INCLUSION (ENDI)

### Universal Access & the Hard to Reach

The end product is convenient while also addressing public health and personal hygiene concerns.

- 3) Innovative contracting arrangements. For the construction of the elevated sanitation facilities, as well as rural water supply technologies (e.g. shallow borehole wells with rope pumps, ferro-cement tanks, etc), WA Nicaragua first trains local artisans in the construction practices, and then facilitates the establishment of a three-way contract between WA Nicaragua, the artisan and the household/client. Under this model, payment to the artisan is contingent on the satisfaction of the household in the quality of the work. This not only ensures quality construction, but stimulates a deeper sense of ownership in the infrastructure by the household.
- 4) Continued encouragement and recognition of household improvements. WA Nicaragua has been implementing innovative approaches to ensure that hygiene outcomes last beyond the lifespan of the programme. One example is the ficha de monitorero de vividenda, which is a household monitoring tool that was adopted by WA Nicaragua.

This tool is integrated into a hygiene education programme carried out by volunteer community health workers. It utilises positive reinforcement of good hygiene practices through periodic household monitoring visits. These visits are carried out by community health workers following an initial sensitisation process that includes community meetings and one-on-one meetings between the head of household and the community health worker. Feedback and support are provided by promoters to the household, and happy or sad water drops are allocated depending on the results of the assessment of practice.

Tracking the progress of household hygiene behaviours using monitoring charts helps health promoters to prioritise households that they should focus on. Monitoring charts have been successfully implemented in 26 communities and have also been adapted for application in schools to track the hygiene and sanitation behaviours of students. Although WA Nicaragua didn’t develop the household monitoring programme, the results of its efforts have encouraged the government of Nicaragua to pursue scaling it up nationally.

### Main results and lessons learnt

Evidence of the impact and progress achieved with modest funding (\$1.5 million) during the first four inception years of the WA Nicaragua programme can be summarised as follows:

1. Coverage: There are more than 20 rural communities and 6 peri-urban communities where WASH services are now being provided. This benefits an estimated 7,500 men, women and children and includes 15 schools. This represents an increase in progress of approximately 5%.
2. Access: Water, sanitation and hygiene were provided to particularly excluded populations including physically handicapped and elderly people.
3. Local capacity: More than 150 men and women were trained and are providing services in their communities and beyond, primarily in the construction of solutions such as rainwater catchment systems, shallow manually drilled borehole wells and pour flush toilets. More than 20 community water and sanitation user associations were formed, trained, and are now functioning.
4. Financing mechanisms: Municipal funding commitments increased from 10% to 20% for the construction of new services. WASH credit products were established with a permanent fund of \$300,000 offered by a local MFI partner.
5. Awareness raising: There was increased involvement of local municipal and autonomous regional government WASH units, particularly in leading events.

## **EQUITY NON-DISCRIMINATION AND INCLUSION (ENDI)**

### **Universal Access & the Hard to Reach**

#### **Conclusions and Recommendations**

WA Nicaragua is going through a growth period following the first four inception years. The programme is being expanded to include work with the Ministry of Health and health facilities and the Ministry of Education and schools, while focusing a greater effort on building a municipal-wide approach with the local government and indigenous territories in the four municipalities of intervention. Development of the local WASH market will continue to address a significant segment of the underserved in both peri-urban and dispersed rural communities, while advocating with local government for smart subsidies to include the most disadvantaged segments of the population.

#### **References**

- AECID (2016) <http://www.aecid.org.ni/cooperacion-aecid/cooperacion-bilateral/>
- Herrera RS, Obando SA, & Casey V (2014) WaterAid Country Programme Evaluation.
- Skat Foundation (2012). Technology Assessment Framework (TAF) and Guidance for Technology Introduction (GTI) – Research Report 2nd Version (WASHTech Deliverable 3.2)
- UNDP (2015) “Human Development Report” Available online at <http://report.hdr.undp.org/>
- WHO/UNICEF (2015) Progress on Sanitation and Drinking Water: 2015 Update and MDG Assessment.
- World Bank (2014) Standard of Living Survey by the National Development Information Institute



EQUITY NON-DISCRIMINATION AND INCLUSION (ENDI)

Universal Access & the Hard to Reach

---

## Investisseur gestionnaire : une approche pour un service durable de l’eau potable à Madagascar

---

Type: Article court

**Auteurs :** RAKOTOMALALA Heritiana Alain, Responsable du Programme EAH<sup>34</sup>, HELVETAS Swiss Intercooperation Madagascar, [Heritiana.Rakotomalala@helvetas.org](mailto:Heritiana.Rakotomalala@helvetas.org), +261 32 84 356 39; Julia RANDIMBISOA, Agnès MONTANGERO.

### Abstract/Résumé

Le service d’approvisionnement en eau potable est en pleine mutation depuis plus d’une décade dans les pays en développement. A Madagascar par exemple, les réformes sectorielles donnent plus de place au secteur privé pour le financement des infrastructures et la gestion des réseaux d’eau potable. L’entrepreneur évolue vers le statut d’investisseur-gestionnaire au lieu de simple prestataire de service. Au-delà de l’aspect investir pour bâtir, l’entrepreneur exploite aussi les ouvrages construits par lui-même. Il assure les maintenances du réseau et fournit de l’eau potable aux ménages suivant un contrat précis avec la commune et le représentant des usagers. Si le service est de qualité et fonctionne de façon continue, il pourra, grâce au paiement des usagers, récupérer le capital investi après quelques années de gestion. Ce modèle sera pérenne avec la bonne gouvernance locale, l’adhésion au service payant et le respect du seuil minimum de rentabilité.

### Introduction

A Madagascar, le taux d’accès au service d’eau potable demeure bas : 43% en 2015 (Ministère de l’Eau, de l’Assainissement et de l’Hygiène, 2016). Comme ailleurs, le système de gestion communautaire montre ses limites et les infrastructures installées peinent à rester fonctionnelles après le départ des projets. Différents éléments, qui ne sont pas l’objet de cet article, dont le financement basé sur la cotisation forfaitaire par ménage bénéficiaire ne prenant pas en compte le recouvrement des coûts d’exploitation, le renouvellement des ouvrages et l’extension des mini réseaux d’adduction peuvent expliquer cette situation.

En 1999, le gouvernement de Madagascar a promulgué son premier code de l’eau. Accompagné des décrets d’application subséquents, il donne les grandes lignes directrices du secteur de l’eau et de l’assainissement du pays : les communes sont les maîtres d’ouvrage (art. 39, 40, 41 et 42), l’accès au service public de l’eau est payant (art. 54), et la gestion des systèmes est déléguée par affermage, gérance ou concession à des gestionnaires privés sélectionnés sur appel d’offre public (art. 46). Bien que le projet accompagne les communes pour jouer leur rôle de maîtres d’ouvrage, ces communes n’ont que peu de moyens à disposition pour investir dans les infrastructures d’adduction d’eau potable (AEP).

Cette situation est propice à l’émergence de partenariats publics-privés (PPP) dans lesquels une entité privée, physique ou morale, reçoit par affermage la responsabilité commerciale et technique de l’exploitation d’un réseau. Elle contribue financièrement à la construction ou à la réhabilitation des infrastructures et devient ainsi à la fois investisseur et gestionnaire.

A l’aide de l’exemple de la mise en place d’un système d’AEP dans la commune d’Anosimena à Madagascar, cet article vise à expliciter les aspects institutionnels et financiers de ce type de PPP, ainsi qu’à donner un aperçu de ses forces et faiblesses.

---

<sup>34</sup> Eau Assainissement Hygiène

## EQUITY NON-DISCRIMINATION AND INCLUSION (ENDI)

### Universal Access & the Hard to Reach

#### Contexte, objectifs et activités

Le village de Masiakampy, dans la région du Menabe, est le chef-lieu de la commune rurale d'Anosimena. Il est subdivisé en six hameaux et se situe à 35 km du centre urbain de Miandrivazo. Masiakampy subit une pression démographique issue d'une migration liée à l'insécurité grandissante dans les localités environnantes. Le nombre de ménages est passé de 160 en 2011 à 791 en 2016.

L'économie dynamique de ce fokontany est basée sur les cultures vivrières (riz et tubercules) et de rente (haricot, maïs et arachide). Le village abrite un port sur les rives du Mahajilo, navigable toute l'année et utilisé pour le transport de marchandises et de touristes, ainsi que pour la pêche.

Avant l'intervention du projet, la commune ne disposait pas de système d'AEP. Les habitants s'approvisionnaient en eau dans des puits ainsi que dans la rivière avoisinante. Certains ménages déléguaient la collecte de l'eau et payaient ainsi jusqu'à 600 Ariary (0,2 USD) le bidon de 20 litres.

Afin d'assurer la pérennité de la gestion du système et de mobiliser des fonds

supplémentaires, il a été décidé de faire appel à un investisseur-gestionnaire privé opérant sous un contrat d'affermage.

En 2015, sous l'impulsion du projet et en concertation avec la commune, un appel à manifestation d'intérêt a été fait, suivi de séance d'information pour les potentiels soumissionnaires portant tant sur les défis de la gestion d'un réseau d'adduction d'eau potable que sur les aspects techniques. Un appel d'offre public a ensuite été passé pour engager un investisseur-gestionnaire. Le marché proposé aux privés est inscrit dans le plan communal de développement du secteur dont la préparation a été préalablement soutenue par le projet. C'est un plan quinquennal qui consigne les priorités villageoises en termes d'investissement et de bénéficiaires de l'action.

Le marché est attribué sur la base de critères techniques et financiers. Les critères financiers sont l'apport en capital propre, le montant total de la subvention demandé, ainsi que le prix du service de l'eau que l'opérateur se propose de pratiquer. Les entreprises soumissionnaires sont en général expérimentées dans la construction d'infrastructure d'eau potable et gèrent ce type d'infrastructures dans d'autres communes. Pour le cas de Masiakampy, l'offre la plus concurrentielle a été soumise par une entreprise active dans tout Madagascar, et déjà en charge de la gestion du réseau d'adduction d'eau de la ville de Miandrivazo. Cette proximité permet d'effectuer des économies d'échelles (les techniciens et le gestionnaire principal peuvent s'occuper des deux réseaux à la fois) et de réduire les frais de déplacement sur le terrain.

Suite à la passation du marché, le contrat de subvention a été signé. Ce contrat fixe les modalités de financement de la construction du réseau. Le gestionnaire a investi 10%, la commune 5% et le projet 85%

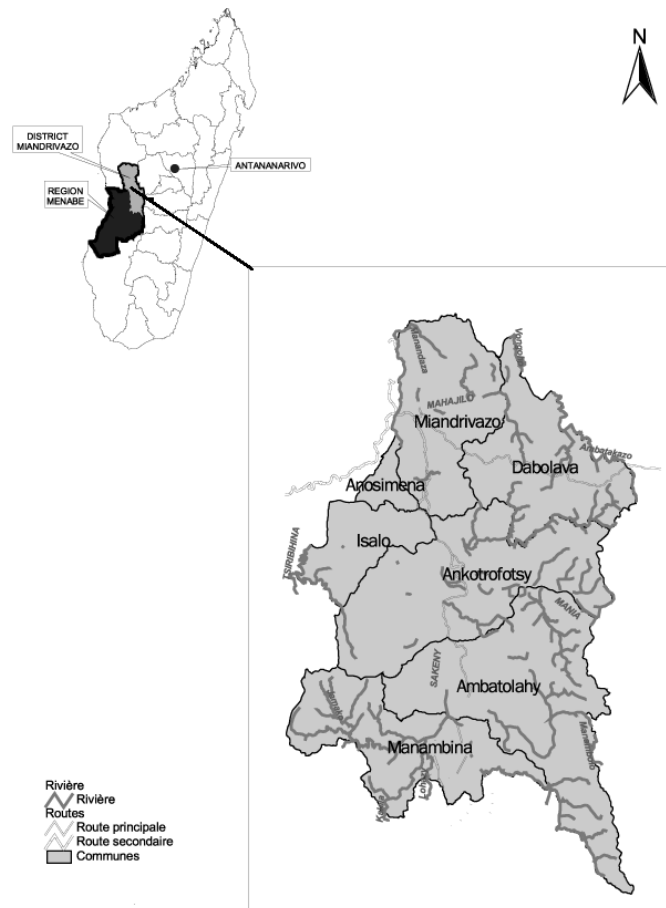

Figure 1 Carte du district de Miandrivazo

## EQUITY NON-DISCRIMINATION AND INCLUSION (ENDI)

### Universal Access & the Hard to Reach

du coût total de la construction du réseau. L'argent est versé dans un compte commun et la subvention reversée par tranche au gestionnaire, la dernière 1 an après la mise en eau du système. Le gestionnaire est responsable de l'exécution des travaux qu'il effectue par lui-même ou qu'il délègue en partie à une entreprise tierce.

Avant la mise en eau du système, le contrat de délégation, qui se base sur la réponse à l'appel d'offre gagnante est signé. Ce contrat porte sur 15 ans et définit entre autres le nombre de branchements à atteindre, le prix du service de l'eau, ainsi que le détail des responsabilités de chaque partie signataire : la commune, le Ministère de l'Eau, de l'Assainissement et de l'Hygiène, l'investisseur-gestionnaire et le représentant des consommateurs.

Le gestionnaire est en charge d'assurer le fonctionnement du réseau. Il couvre entièrement les frais d'opération et de maintenance du réseau pendant sa période d'affermage. Il est tenu d'assurer un approvisionnement continu d'une eau de qualité satisfaisante et en quantité suffisante. Il offre trois types de branchements :

- Les branchements particuliers: chaque ménage qui a les moyens de payer un branchement avec un robinet sur sa propriété. Le tarif pour ce type de branchement est de 3 Ariary/litre (0.001 USD). Ce prix est relativement élevé, le prix dans d'autres projets variant de 1 à 2.5 Ariary/litre (0.0004 à 0.0008). Il est à expliquer par des facteurs techniques (forage et pompage), ainsi que la taille relativement faible du réseau.

Le prix d'un branchement particulier est d'environ 200'000 Ariary (65 USD). Afin de faciliter l'accès, un subventionnement a été mis en place : le projet prend en charge la moitié du coût de branchement et le gestionnaire offre la possibilité de payer le compteur de manière échelonnée (2'000 Ariary (0.65 USD) par mois pendant 4 ans). Le prix du service de l'eau pratiqué ne semble quant à lui pas être un blocage : certains ménages possédant un branchement revendent leur eau à 5 Ariary/litre (0.0016 USD) à leurs voisins.

- Les branchements partagés : jusqu'à une dizaine de foyers sont regroupés autour d'un seul point d'eau. Les ménages s'organisent entre eux pour l'utilisation et le paiement de la facture. Le prix de l'eau est inférieur à celui au branchement particulier, soit de 2.5 Ariary /litre.
- Un kiosque à eau : il est destiné aux ménages n'ayant pas la capacité financière de se brancher et permet au gestionnaire de répondre à son obligation de fournir du service public (impliquant un accès universel au service). Il sert aussi pour les clients de passage. Comme dans la plupart des cas rencontrés à Madagascar, le prix du service de l'eau y est égal à celui du branchement partagé. Le gestionnaire est en charge du bon fonctionnement du kiosque. Il en assure l'entretien et engage un fontainier. Celui-ci est en charge de la vente d'eau aux heures d'ouverture du kiosque et reverse l'argent collecté au gestionnaire. Il est payé de manière forfaitaire. Les investisseurs-gestionnaires tendent de manière générale à minimiser la présence de ces kiosques car ils représentent des charges fixes importantes (salaire du fontainier) et le volume d'eau vendu n'est pas significatif (environ 15 litres par personne et par jour) par rapport au minimum de 25 litres pour un branchement particulier.

La gestion du réseau permet à l'investisseur-gestionnaire de récupérer son investissement dans un délai prévu de 8 ans (5 à 8 ans en général pour d'autres projets à Madagascar) et dégage un bénéfice après 5 ans. L'analyse de la répartition des coûts d'investissement, d'exploitation et de réhabilitation donne un coût total de 5.4 USD par personne et par année pour ce système. Il est important de noter que ces chiffres se basent sur les valeurs théoriques telles que proposées par le plan commercial de l'investisseur-gestionnaire et n'incluent pas les coûts d'appui directs et indirects. De même, le coût d'investissement ne comprend pas les travaux et études réalisés antérieurs à la construction du système. La durée de vie des installations a été estimée à 20 ans et la population considérée est celle du dernier recensement exact fait par le projet (soit 2'358 personnes réparties en 536 ménages).

## **EQUITY NON-DISCRIMINATION AND INCLUSION (ENDI)**

### **Universal Access & the Hard to Reach**

Les salaires représentent la charge la plus importante avec près de 60% du coût total. Les coûts d’investissement représentent 19% et les coûts de réhabilitation 8%. Les recettes théoriques permettent de couvrir l’ensemble des coûts théoriques pris en compte par le gestionnaire. Cependant, au-delà des coûts non considérés dans cette analyse, les coûts de réhabilitation paraissent peu élevés et devraient être financés par un réinvestissement des bénéfices de l’investisseur-gestionnaire ou une augmentation des taxes communales.

### **Figure 2 Coûts théoriques à long terme**

La commune est le maître d’ouvrage et le premier responsable de l’accès de ses administrés aux services sociaux de base dont l’eau fait partie. Elle définit les sous-projets, prévoit le budget y afférent, mobilise les ressources existantes et exécute les plans d’actions au bénéfice des ménages vulnérables. Elle fixe les taxes et les redevances que le gestionnaire doit payer selon les recettes enregistrées. Dans le cas de Masiakampy, 5% de taxes sont prélevées sur le volume de la vente d’eau. Elles sont destinées à des activités qui doivent être liées au service du même secteur tel que l’extension du réseau, le subventionnement de certains branchements (pour les établissements publics par exemple) ou assurer le fonctionnement d’un Service technique eau assainissement et hygiène (STEAH).

Le rôle du STEAH est d’élaborer, de renseigner et d’exploiter le tableau de bord du secteur au niveau de la commune pour informer sur l’évolution de la consommation en eau potable et la régularité du versement des taxes et redevances communales. Il est un interlocuteur clé faisant le lien entre la commune, l’investisseur-gestionnaire et les usagers de l’eau.

La structuration des usagers en une organisation de la société civile va influencer sur la continuité et la qualité du service offert par des rappels et/ou des dénonciations sur la non-allocation du budget au secteur, ainsi que par des animations pour le paiement des consommations. Cette société civile constitue une force de proposition et plaide en faveur de toute la population pour l’exercice du droit fondamental qu’est boire de l’eau potable pour vivre en bonne santé.

Le projet, en collaboration avec la Direction régionale de l’eau, renforce les capacités de la commune et des usagers et veille au respect des textes et normes en vigueur du secteur.

### **Résultats principaux et leçons tirées**

## **EQUITY NON-DISCRIMINATION AND INCLUSION (ENDI)**

### **Universal Access & the Hard to Reach**

Cette approche représente un mécanisme local de financement. Le schéma permet d'impliquer à la fois le public et le privé pour le développement du secteur et un dispositif de redevabilité réciproque s'instaure. Dans le contexte de Madagascar, le secteur privé apporte en général de 10 à 20% des financements, tandis que la commune contribue à hauteur d'environ 5%.

Comme le montre ce cas, l'apport en capital du privé permet d'augmenter l'accès au service et l'amélioration de sa qualité dans un périmètre donné, ainsi que d'assurer une bonne gestion à long terme du réseau d'adduction mis en place. Dans d'autres expériences d'HELVETAS Swiss Intercooperation, cette pérennisation du service a pu être démontrée. La gestion des kiosques à eau et lavoirs (46 au total) d'une petite ville d'environ 40'000 habitants (Tsiroanomandidy) a par exemple été déléguée à un gestionnaire privé qui assure depuis 2006 leur exploitation et entretien.

L'adhésion des ménages au service payant est motivée en plus des raisons économiques et/ou sanitaires par des arguments touchant les émotions sociales. Il semblerait que même pour les ménages les plus vulnérables, les prix pratiqués aux kiosques sont abordables pour assurer au moins un approvisionnement d'eau pour la consommation.

Au niveau institutionnel, il paraît important de s'assurer que la commune soit dotée d'un STEAH et dispose des moyens pour le maintenir. Ce service est clé dans les relations entre les différentes parties prenantes et il assure le bon fonctionnement de la redevabilité entre le gestionnaire, la commune et les clients. Le modèle sera pérenne avec l'application par la commune de mesures adéquates pour la gestion du contrat de délégation, le paiement des consommations et la mise à disposition d'un service de qualité de la part de l'investisseur-gestionnaire.

Finalement, les expériences acquises à Madagascar montrent que, même dans un contexte peu favorable, ce type de partenariat peut intéresser des investisseurs privés sous certaines conditions : périmètres de délégation de plus de 2'000 habitants permettant à l'investisseur-gestionnaire d'effectuer des économies d'échelle (réduction des charges fixes - tels que les salaires, véhicules et locaux – et variables – économies d'échelle sur les pièces de rechange par exemple), un certain dynamisme économique permettant aux usagers d'avoir un revenu monétaire régulier pour pouvoir s'offrir un branchement particulier et un système nécessitant un minimum de ressources énergétiques additionnelles. Les projets peuvent influencer ces facteurs en essayant de regrouper dans un même appel d'offre un système dans un centre rural dense (et profitable pour le investisseur-gestionnaire) et des systèmes moins profitables dans les villages avoisinant. Les projets peuvent également contribuer à soutenir le potentiel économique d'une région en couplant l'intervention dans le domaine de l'eau potable avec des activités génératrices de revenus.

### **Conclusions et Recommandations**

Le modèle investisseur-gestionnaire permet donc de mobiliser des investissements locaux supplémentaires pour la construction ou la réhabilitation de réseaux d'adduction d'eau potable et d'assurer une pérennisation du service sur le long terme. Les aspects du contexte socio-économique (dynamisme économique) et politiques (soutien du gouvernement aux PPP et à la tarification du système de l'eau) et les spécificités techniques (type de système d'AEP) jouent un rôle important dans la potentielle viabilité du service. De plus il est primordial que le système puisse être rentable. Il est important que la commune, soutenue par les projets, mettent en place des périmètres de délégation avec des systèmes permettant un retour sur investissement dans les 5 à 7 ans, tout en maintenant un prix abordable pour toutes les catégories de population. Il est aussi capital de bien comprendre les aspects contextuels, techniques et commerciaux avant de mettre en œuvre un tel projet. Des variantes du modèle d'investisseur-gestionnaire doivent être expérimentées pour les petits systèmes isolés pour lesquels la rentabilité du service ne peut pas être assurée.

## **EQUITY NON-DISCRIMINATION AND INCLUSION (ENDI)**

### **Universal Access & the Hard to Reach**

#### **Mentions**

Les contenus de l'article sont issus des expériences de deux programmes à Madagascar :

- *Le Programme MUNSINGEN se réalise dans le cadre d'une coopération décentralisée de la commune de Muensingen en Suisse dont la mise en œuvre est confiée à HELVETAS Swiss Intercooperation Madagascar*
- *Le Programme RATSANTANANA cofinancé par la DDC<sup>35</sup> entre dans le Swiss Water and Sanitation Consortium Phase II est exécuté par HELVETAS Swiss Intercooperation Madagascar en partenariat avec l'ONG malgache TARATRA*

---

<sup>35</sup> Direction du Développement et de la Coopération Suisse

EQUITY NON-DISCRIMINATION AND INCLUSION (ENDI)

Universal Access & the Hard to Reach

## Social cases: Reaching Universal Access to Water Supply at Community Level

Type: Short Paper

**Authors** *Viacheslav Sorokovskyi; Decentralisation/Public Services expert, Swiss-Ukrainian Decentralisation Support Project to Ukraine DESPRO, Ukraine, email: v.sorokovskyi@despro.org.ua, tel: +380958952293*

### Abstract/Summary

After the breakdown of the Soviet Union, the centralised water supply systems in rural areas in Ukraine were no longer allocated sufficient funds for their operation and maintenance. Many of the piped systems broke down and the level of service provision was low. Funds for establishing new water networks were also lacking. In this context, new piped water systems require financial contributions from households, which most families can afford. However, for families on very low income such contributions may not be possible so they cannot get access to an improved water supply. A method of identifying *Social Cases* – households that require subsidised access at community level - was developed by DESPRO/Skat and introduced in 20 partner villages. In this approach, the community is given the task to identify the families with special needs and approve a special policy regarding their financial participation in the new water service. The approach considers equity and inclusion and contributes to universal access to improved water supply at community level.

### Introduction

Situated in Eastern Europe, Ukraine is one of the largest countries in Europe. Its territory is about 603,600 sq.km<sup>36</sup>, with a population of 42.6 million, with 30.8% (13.3 million) people living in rural areas<sup>37</sup> (*UKRSTAT, 2015-16*). Agricultural and industrial goods are important contributors to Ukrainian economy, which stood at Gross Domestic Product (GDP) per capita at USD 2,081.04 in 2014 (*World Bank, 2016*).

After the breakdown of the Soviet Union in 1991, a lack of local capacities, clear institutional and financial set-ups for water supply at national level, as well as little experience of social mobilisation led to a critical decrease of water supply in rural areas. Over years of independence, coverage of piped water supply in rural areas has dropped from 50 to 22 percent (*WHO/UNICEF, 2014*).

DESPRO is a Ukraine-based project on decentralisation, funded by the Swiss Agency for Development and Cooperation (SDC) and implemented by Skat, Switzerland. In the period between 2007 and 2013, DESPRO supported implementation of around 80 water supply projects in three regions in Ukraine. The projects built water networks, fed by one or more deep boreholes, that supply households with water with at least backyard connection (however, 75% of households have installed in-house connections afterwards). The different community-based solutions for project implementation, as well as further operation and maintenance have been used, e.g. public associations, service cooperatives (*Sorokovskyi, Olschewski, 2012*).

Community-based solutions show good results in terms of equity and inclusion: those families with low incomes but who want an improved water supply are provided with different participation schemes. Consequently, the coverage of households with an improved water supply, in the target territory, increased from a baseline of 0-15% to 92-96%. The post-construction monitoring done by DESPRO and local

36 Since spring 2014 territories of Autonomous Republic of Crimea and Sevastopol city have been annexed by Russian Federation. A part of Ukrainian territory in the East is controlled by illegal armed groups – self-recognized “Donetsk People’s Republic” and “Luhansk People’s Republic”.

37 Number of population on territories of Autonomous Republic of Crimea and Sevastopol city are not taken into account.

## EQUITY NON-DISCRIMINATION AND INCLUSION (ENDI)

### Universal Access & the Hard to Reach

partners in 2-3 year after project completion showed that nevertheless there were households (obviously 4-8%) for which the requirement to make a financial contribution has become a limiting factor in obtaining better water supply.

#### Context, aims and activities undertaken

At the initial stage of project planning households are usually asked to present their willingness to join the community project. Obviously, a motivating factor for this is a need to have a better water supply. So, what could be the reason for some households of not connecting to the network? Those households that have an obvious need for a better water supply but are neither able to make a financial contribution for the water supply system construction nor pay for the connection (a service pipe to the yard is the minimum) are referred as “*Social Cases*” and require special policy.

But, how can the community identify *Social Cases* properly? Below are some common cases where households may not wish to (initially) participate in the the water supply project for reasons other than poverty:

#### **“No need but capable”**

Where a municipal water supply is not available – or unreliable – some households meet their own needs using self-supply technologies. For example, a household, or group of households, may build a mini-system comprising a pumping station, a water main to the house, in-house plumbing to service the kitchen, toilet, bathroom and other water uses. Such householders may think the matter of water supply is fixed so often, at initial stage of the project implementation, they are not motivated to contribute additional funds. However, it commonly happens that after the project is completed such households nevertheless connect to the centralised water supply system, paying the contribution to the cost of the network itself and also for the connection. Since for such households financial contribution is not limiting participation in the project, they should not be considered as *Social Cases*.

#### **“Need but not capable”**

The attitude of such households to the participation in the water supply project may be characterised as follows: **“I need it, wish it, but I am not capable to pay a contribution”**. At the same time there are a mix of financial, social and pride/self-esteem factors that influence the behaviour of individuals and, in fact, prevent them saying: “Yes, I need to connect and I need help because I don’t have enough money”. Not wanting to admit their problem to others, such households may subjectively assess their own needs as “rather do not need” or their wish as “rather do not wish”. “*How much water do I need? Maybe one bucket a day will be enough for me,*” similar excuses can be heard often. Evidently, at the end such households would rather continue to use shallow wells than to ask for special financial support. Objectively, the quality of ground water in the most territories of Ukraine fails to comply with the quality standards of drinking water. So, the households not connecting the network would then compromise their financial problems with lower quality of water used. Such households may qualify as *Social Cases*, but if they are not willing to identify themselves and put themselves forward for support, then they need to be found through other means.

#### **How to assess the level of income**

In practice, it is not easy to reveal *Social Cases*: the level of income earned by a household may be one of the indicators, but – especially in rural areas – it is difficult to determine the real level of income only on the basis of formal measures. In our opinion, it is not worth determining the low-income level strictly in accordance with formal criteria because this information is usually based on survey responses from residents themselves and there is often a disparity between the income declared and the actual amounts earned because:

- (a) there is a tendency of individuals to understate the level of earned income if there is no need to provide a documented evidence;
- (b) it is common that the individuals may only consider the salary (or pension) or similar types of income (for instance, for one-off job or contract work) as their income;



## EQUITY NON-DISCRIMINATION AND INCLUSION (ENDI)

### Universal Access & the Hard to Reach

- (c) unofficial income, especially occur in the rural areas (for instance, for the land cultivation services by one's own machinery, construction and repair works, fishing, renting of dwellings in resort areas, etc.) as well as the income earned from individual household farming may be concealed or not reported (*see Box 1*).

#### **Box 1. Example of difference in household income data depending on sources**

During the Customer's Satisfaction Survey on the quality of water supply service (DESPRO, 2012), there was assessed the share of the family's income spent on water supply. The data on average monthly water bill was compared with the average monthly aggregate family income. According to the **responses of representatives of households**, in Vinnitsya Region, the average monthly aggregate family income totaled UAH 1,354, (in 2012, 1USD = 8 Ukrainian Hryvnia (UAH)) and in the Autonomous Republic of Crimea - UAH 1,351. This data significantly differs from the **state statistics** data. Thus, the actual average monthly income per capita for 2011 in general equalled UAH 1,770.8 in Ukraine. According to the DESPRO data, the average number of members of one household in target communities was 2.77 people: in Vinnitsya Region, 2.4 people, in the Autonomous Republic of Crimea, 3.1 people. Hence, in terms of one household, in general, the actual average monthly income totals UAH 4,911.00, and by regions: in the Autonomous Republic of Crimea - UAH 5,472.00, in Vinnitsya Region - UAH 4,250.00. As we can see, the difference between the own assessment and the statistics differs by more than three times.

#### ***Who and how shall make a decision on social cases?***

Therefore, as the practice proves, the determination of *Social Cases* in villages takes place according to the principle: "in community, they know who is who".

The following, community-led, procedure on identifying and dealing with *Social Cases* has been introducing and testing in DESPRO partner villages since 2014.

- Step 1. The Project Implementation Group<sup>38</sup> shall analyze the needs and capabilities of all households in terms of their participation (including financial contribution) in the project.
- Step 2. The criteria of assigning households to the category of *Social Cases* shall be established by the Project Implementation Group and approved at the general meeting of the community.
- Step 3. According to the established criteria, the Project Implementation Group shall collect the information and data regarding any potential *Social Cases*, analyze the information and data obtained, draw up a preliminary list of households to be assigned to the category of *Social Cases*.
- Step 4. The decision on the assignment of households to the category of *Social Cases* for the purposes of the project implementation shall be made by the general meeting of the community, with the mandatory entry of information about that decision in the minutes.
- Step 5. The decision on special conditions regarding financial contribution in the project implementation as agreed with specific households shall be made by the general meeting of the community, with the mandatory entry of information about that decision in the minutes.

Among other clauses, the special conditions may include: full or partial exemption from the payment, payment in instalments, replacement of financial contribution with the in-kind one or another arrangement that is agreed by all parties.

---

<sup>38</sup> The *Project Implementation Group* is an auxiliary body for the Village Council in the course of the project implementation. It is a formal body established by legal act of the Village Council (local self-government body). The Project Implementation Group is aimed to be one of the strong mechanisms of social mobilisation. As a rule, the composition of the Project Implementation Group equally represents both the Village Council and the local activists delegated by the community.

## EQUITY NON-DISCRIMINATION AND INCLUSION (ENDI)

### Universal Access & the Hard to Reach

#### “Checks-and-balances”

It would be too optimistic to expect that the community will decide fairly on *Social Cases* in absolutely all situations. Who can defend the households – which according to apparent characteristics have to be assigned to the category of *Social Cases* – but whose interests are not evidently taken into account by the community? Due to the approach, the final word is with the Village Council<sup>39</sup>. So, if the general meeting fails to make the decision regarding *Social Cases* not taking into account evident conditions, such decision shall be made by the Village Council as it possesses the ultimate responsibility for water supply in the community. In this connection, the Village Council which has made the decision shall have the right to allocate, within the limits of budget financing, a portion of funds that will be channelled for the coverage of a contribution for the construction of and/ or payment for the connection of households to the water supply system instead of the households falling under the category of *Social Cases*.

It is also important to mention that in Ukraine the issue of *paternalism* doesn’t take place at community level. It means that more powerful (and, in fact, richer) families in the village would not have a chance to propose themselves for financial support. Even being presented in the Project Implementation Group or having certain connection to the Village Council.

#### Main results and lessons learnt

The *Social Cases* approach has been introduced and implemented in 20 partner villages in five regions of Ukraine. The requirement for considering and deciding on *Social Cases* by community was set as one of the criteria to get co-financing from DESPRO. Eventually, in most situations the community could resolve the issue of *Social Cases* in the general meetings. In two villages, however, the decision had to be made by the Village Council.

The number of *Social Cases* varies from 3 to 7 families per village. Considering that a typical project covers between 150 and 200 households, the share of social cases in total target group is less than 5%. This figure shows the share of households who are not able to cover financial contributions at the beginning of project implementation. It corresponds with the results of post-construction monitoring (see Introduction). It can be concluded that if these households were not considered as *Social Cases* few would gain connection to the network and an improved water supply.

As per reports of partner communities, the social structure of households assigned as *Social Cases* include: families with many children; single elderly people; disabled people; and families with children that lost their father in the military conflict in the East of Ukraine.

Many partner communities also reported that a positive side-effects that occurred during consideration of the *Social Cases* included better community cohesion, conflict resolution and closer interaction among community members, on the one hand, and between community and local council, on the other.

#### Conclusions and Recommendations

The *Social Cases* approach presented in the paper has proven to be an important component of social mobilisation. In project approaches where financial contribution from households is required, *Social Cases* approach can help achieve universal access to water. The approach as such doesn’t have any national specificity, so it can be applied widely. The differences in application may fall into set of criteria that has to be established in a community. Equally, proper introduction and use of the *Social Cases* cases approach may require certain degree of community development, such a minimum level of community cohesion, trust, decision-making and financial management capacity. In other situations, some facilitation might be needed to support the community in reaching common understanding and agreement.

---

<sup>39</sup> The *Village Council* as an elected local self-government body which by law is responsible for the arrangement of provision of public services, including in particular, water supply in the relevant territory. It is also responsible for the distribution of funds appropriated for the implementation of measures aimed, in particular, at the water supply. Within project implementation modalities by DESPRO the Village Council is the implementing body of the project for improvement of water supply.

## **EQUITY NON-DISCRIMINATION AND INCLUSION (ENDI)**

### **Universal Access & the Hard to Reach**

#### **Acknowledgements**

*The author would like to thank the Swiss Agency for Development and Cooperation (SDC) and Skat for their on-going support of DESPRO and to the people and local government partners with whom we have been able to achieve substantial success. The special gratitude the author would like to show to Sean Fury (Skat) for assistance and comments that greatly improved the paper.*

#### **References**

- STATE STATISTICS SERVICE OF UKRAINE. (2015-2016) ‘*Current Population of Ukraine: Reports (2015-2016)*’. Available at [http://database.ukrcensus.gov.ua/pxweb2007/ukr/publ\\_new1/2015/zb\\_nas\\_14.pdf](http://database.ukrcensus.gov.ua/pxweb2007/ukr/publ_new1/2015/zb_nas_14.pdf). [Accessed 03 May 2016].
- WORLD BANK. (2016) ‘*Ukraine GDP per capita: 1987-2016*’. Available at <http://www.tradingeconomics.com/ukraine/gdp-per-capita>. [Accessed 03 May 2016].
- WHO/UNICEF. (2014) ‘*Progress on Sanitation and Drinking-Water: 2014 Update*’. Available at [http://apps.who.int/iris/bitstream/10665/112727/1/9789241507240\\_eng.pdf](http://apps.who.int/iris/bitstream/10665/112727/1/9789241507240_eng.pdf). [Accessed 03 May 2016]
- SOROKOVSKIY, V., OLSCHIEWSKI, A. (2012) ‘*Service Cooperatives – Solutions For Rural Water Supply In Ukraine*’. Available at [http://despro.org.ua/media/articles/av\\_despro\\_01\\_2012\\_eng.pdf](http://despro.org.ua/media/articles/av_despro_01_2012_eng.pdf). [Accessed 04 May 2016]
- DESPRO. (2016) ‘*Rural Drinking Water Supply: From Idea to Implementation (UKR)*’. Available at [http://despro.org.ua/upload/medialibrary/DESPRO\\_2016\\_Silske\\_vodopostachannia\\_Posibnyk\\_ta\\_Dodatky.pdf](http://despro.org.ua/upload/medialibrary/DESPRO_2016_Silske_vodopostachannia_Posibnyk_ta_Dodatky.pdf). [Accessed 04 May 2016]

EQUITY NON-DISCRIMINATION AND INCLUSION (ENDI)

Universal Access & the Hard to Reach

## Rights to water and sanitation for People with Disabilities in Madagascar

Type: *Short Paper*

**Authors:** *WaterAid Madagascar*

*Près lot II Y 53 bis, Avaratra Antanimora - Antananarivo*

*Tel: + 261 (0) 34 14 693 27 / + 261 (0) 20 22 303 74*

*E-mail: [EdithVeromaminaina@wateraid.org](mailto:EdithVeromaminaina@wateraid.org)*

*[www.wateraid.org](http://www.wateraid.org)*

### Abstract/Summary

This paper illustrates the experiences of the Platform For People with Disabilities (PFPH), working with the support of WaterAid, to highlight and address the gaps in the realisation of the rights of people with disabilities in Madagascar. The focus has been on engaging the government on the National Inclusion Plan for people with disabilities, which includes water, sanitation and hygiene (WASH). This pilot project was designed to increase access to safe WASH for people with disabilities through a human rights based approach. It focuses on strengthening the capacities of rights holders, as well as the capacity and the political will of duty bearers to fulfil their obligations towards the progressive realisation of rights. The project has strengthened the capacity of the PFPH to advocate for their rights and engage with government on all areas of their rights, although an increase in actual WASH provision is limited by the government’s lack of capacity and resources.

### Introduction

WaterAid puts human rights at the centre of its Global Strategy 2015 – 2020 (WaterAid, 2015). Studies have shown that where a community improves its water supply, hygiene and/or sanitation then health improves. For instance, WHO confirmed that diarrhoea can be reduced by 26% when safe water, hygiene and sanitation are supplied (WHO, 2014). Therefore, access to water services, sanitation and adequate hygiene makes an important contribution to the realization of rights of persons with disabilities.

Between 2013 and 2018 WaterAid has implemented eight pilot projects in eight of the countries it works in to understand how to apply a rights based approach in its work. The same elements were used in each country but adapted to the specific context of the country and the particular issues faced by excluded groups in each context. All of these pilot projects included the following elements:

1. A comprehensive analysis of the rights, power, environment, risk and barrier where the project will be executed
2. A change in the power relations between the excluded groups and duty bearers and other holders of power through:
  - a. The acquirement of skills and power by the excluded groups (in this case people with disabilities)
  - b. More accountability and responsiveness of duty bearers vis-à-vis the excluded
  - c. The improved capacity of the excluded, the duty bearers and other influence groups
  - d. Improving governance for the excluded
  - e. Sustainable system change
3. The existence of a strategic logic in program change activities
4. Monitoring progress in each of these elements of the approach.

## **EQUITY NON-DISCRIMINATION AND INCLUSION (ENDI)**

### **Universal Access & the Hard to Reach**

In Madagascar, WaterAid developed a partnership with the PFPH to understand how:

- To ensure that persons with disabilities enjoy their rights to water and sanitation
- The rights to water and sanitation can facilitate the enjoyment of other basic rights for people with disabilities

This was the only project of the eight pilots that specifically focussed on the rights of people with disabilities.

### **Context, aims and activities undertaken**

#### **Context:**

The Government of Madagascar has ratified the International Convention of the Rights of Persons with Disabilities (CRPD) and has developed a National Inclusion Plan for people with disabilities. This includes WASH. As part of this, the Government is preparing to gather data on people with disabilities as they plan to include disability issues in general census programs.

People with disabilities access to WASH, is still very low. The inaccessibility of infrastructures make the situation more difficult. Despite efforts by the actors such WaterAid and his partners, Handicap International, the implementation of accessibility standards is very limited and depends on their good will.

WaterAid Madagascar’s pilot project with the PFPH was conducted at five localities: Nosy Be, Antsohihy, Ambatondrazaka, Tsiroanomandidy and Morondava.

The main criteria for selecting areas of intervention was based on:

- The geographical and cultural diversity: the five chosen areas are geographically and culturally diverse. Nosy Be and Antsohihy are in the the North; Morondava is in the Southwest; Ambatondrazaka is in the central, east, and Antsirabe and Tsiroanomandidy are in the central highlands.
- The existence of at least one active association and / or support structure for people with disabilities: each locality has between one and eight associations for people with disabilities. Only Nosy Be, which has no support structure for people with disabilities.

The following steps were carried out in the pilot project:

- Analysis of the rights, power, barriers and risks facing people with disabilities. This was undertaken by both local actors (people with disabilities and local officials) and by members of the National PFPH.
- The project then focused on the compilation, enhancement and shaping of information from the field.
- Building local associations’ and local PFPH branches’ capacities through training, structuring and technical support, equipment and operation, with the aim of enhancing the skills of persons with disabilities associations, to make them more dynamic and able to defend their rights.
- The Local associations identified actions to improve their daily life and visibility and to encourage local authorities to advance a more favorable change in the lives of people with disabilities.
- Capacity building for the duty bearers through training on various types of disabilities and appropriate accompanying measures for each type of disability, including the relevant disability rights laws and accessibility standards.

## EQUITY NON-DISCRIMINATION AND INCLUSION (ENDI)

### Universal Access & the Hard to Reach

#### Main results and lessons learnt

Through this pilot project, we can confirm that:

- Rights holders' perceptions of their rights remain crucial in the realization of rights and in fulfilling their rights- claiming roles: This is an essential step which will enable them to identify specific actions and ensure their involvement during all the processes.
- The dissemination of accessibility standards for the duty bearers and the organizations working with people with disabilities is still lacking in some places. This adds to the lack of awareness of the duty bearers of the rights of persons with disabilities to access to water, sanitation and hygiene. But even when policy makers and operators are aware of these rights and standards, they do not always implement them because of the lack of will to act and the lack of resources. This includes a lack of financial resources, which is often the reason given for inaction.
- Nevertheless, the awareness of the duty bearers about their responsibilities towards people with disabilities is evident from the legal texts, policies and strategies at national and regional levels. For example for Madagascar, the Ministry of Water, Sanitation and Hygiene has decided to act in favor of people with disabilities through its strategic guideline for water, sanitation and hygiene (MINEAH, 2015). This sets out the Ministry's commitment to ensure: "Special consideration of vulnerable groups; Application of a suitable charging scheme; Compliance with accessibility standards" (ibid). The involvement and dynamism of people with disabilities in the various working groups and networks around the WASH sector allows them to strengthen advocacy efforts to push through these commitments and then to track changes.
- The importance of awareness to the existence of budget line for people with disabilities and funds in regional and local level: special funds in the regional budget, equity funds for health, relief funds in the municipal budget. Previously, the rights holders were not aware of the existence of these budget lines and this ignorance has allowed the duty bearers to use these funds for other purposes, not related to their cause.
- The analysis carried out through workshops and exchanges confirms that we must respect the priorities of the Disabled Persons' Organisations and work on employment rights, health and education. These three fundamental rights will contribute to the progressive realization of rights in WASH through its cross cutting nature.
- An example of enjoyment of rights: A local branch of a microfinance organisation, Ombona Tahiry Ifampindramana Vola , has extended five loans to people with disabilities for the first time. This has been successful and a further five individuals were offered loans, although these did not materialise for a variety of reasons. The person responsible for giving the loans is planning to provide further loans to the five people who have already had loans, and extend loans to further people with disabilities. She sees the initiative as having been successful, and did not find any particular problems in working with the people with disabilities compared to the non-disabled population.
- While progress on the specific issues of water, sanitation and hygiene are still at a very low level in this commune, wider issues of inclusion are being confidently addressed. The duty bearers are engaging with the issues presented to them, even with the limited resources available to them. Through this project, the awareness of disability rights, and how to include people with disabilities into the social, cultural and economic activities has been invaluable. It can well be imagined that when water and sanitation issues are discussed generally (and there is a lot to be done on this area in the town) there will also be dedicated time and energy given to the needs and rights of people with disabilities.

#### Conclusions and Recommendations

In terms of recommendations, we can highlight the following points:

## EQUITY NON-DISCRIMINATION AND INCLUSION (ENDI)

### Citizen Empowerment & Inclusion

#### Partnerships:

The partnership with the PFPH should be started by developing a long-term capacity building plan. Despite its structure, which is operational, it is always necessary to ensure the managerial, structural and organizational capacity. The approach adopted by the PFPH, which they call "permanent contact" allowed them to strengthen the accountability of duty bearers.

#### Financing/resourcing

To prevent duty bearers continuously falling back on the excuse that the lack of resources prevents them from upgrading of infrastructure standards, it is really essential to reinforce sensitization campaigns and provide information right from the start of the project. We must also empower government both at national and regional level to enable them to promote a greater awareness to all actors of the importance of upgrading of infrastructure standards. We must also intensify fundraising measures for the financing of national inclusion plan for Madagascar.

#### Awareness raising

Rights holders' perception of their rights remains crucial in the realization of rights and in fulfilling their rights claiming roles; the first action should be the information sharing about what are their rights and how to claim them.

#### Providing accessible information

Promote access to information for the groups involved and support their participation throughout the decision-making process regarding their cause.

#### In conclusion

Our experiences show the importance of mobilizing excluded groups such as people with disabilities' and strengthening their capacity which can trigger a change in the system and change the power relations between rights holders and duty bearers. Among others, it is important to highlight the importance of people with disabilities' participation in policy making to inform policy makers of their situation, the restrictions they are facing and ways to overcome barriers to fully enjoy their rights.

#### Acknowledgements

Thanks to WaterAid Madagascar to support us and allocate financial and technical resources necessary to achieve the pilot project. Gratitude to the Platform Disability Federations of Madagascar (PFPH/MAD) for their unconditional support and assistance during the field visits in five localities for this documentation.

#### References

- WaterAid (2015), *Everyone, Everywhere, 2030. WaterAid's Global Strategy 2015 – 2020*. Available at <http://www.wateraid.org/uk/who-we-are/our-strategy>
- Ranjatoson Rivo (Juin 2015), “*Documentation de l’Approche basée sur les droits humains*”, *Projet de la Plate-forme des Personnes en situation de Handicap à Madagascar*
- MEAH (Ministère de l’Eau, de l’Assainissement et de l’Hygiène) (2015), *Lignes directrices du secteur eau, assainissement et hygiène, Période 2015-2019* Available at [http://www.pseau.org/outils/ouvrages/Ministere\\_de\\_l\\_eau\\_de\\_l\\_assainissement\\_et\\_de\\_l\\_hygiene\\_lignes\\_directrices\\_du\\_secteur\\_eau\\_assainissement\\_et\\_hygiene\\_periode\\_2015\\_2019\\_2015\\_Madagascar\\_.pdf](http://www.pseau.org/outils/ouvrages/Ministere_de_l_eau_de_l_assainissement_et_de_l_hygiene_lignes_directrices_du_secteur_eau_assainissement_et_hygiene_periode_2015_2019_2015_Madagascar_.pdf)
- World Health Organization (2014) Preventing diarrhoea through better water, sanitation and hygiene: exposures and impacts in low- and middle-income countries. Available at [http://apps.who.int/iris/bitstream/10665/150112/1/9789241564823\\_eng.pdf](http://apps.who.int/iris/bitstream/10665/150112/1/9789241564823_eng.pdf)

### 3.1.3 Citizen Empowerment & Inclusion

## EQUITY NON-DISCRIMINATION AND INCLUSION (ENDI)

### Citizen Empowerment & Inclusion

# Bollywood Power: Using films and celebrities to talk water

Type: Short Paper

**Authors** *Ankita Bhalla*, Web and Social Media Coordinator, WaterAid India, India, [ankitabhalla@wateraid.org](mailto:ankitabhalla@wateraid.org), +91-9810360492; *Anil Cherukupalli*, Media & Communications Manager, WaterAid India, [anilcherukupalli@wateraid.org](mailto:anilcherukupalli@wateraid.org), +91-9999833440}

### Abstract/Summary

India faces huge water challenges. The growing population is putting a severe strain on the country's natural resources. Most water sources are contaminated by sewage and agricultural runoff. India has made progress in the supply of water to its people, but gross disparity in coverage and quality exists across the country. But what also contributes to the problem is mismanagement and indifferent attitude of people towards water and its conservation. In an effort to get people talking and take action on these important issues using the powerful medium of film and the Hindi film industry, popularly called Bollywood, WaterAid India partnered with the Director and Producer of the Hindi film *Kaun Kitney Paani Mein* (KKPM). KKPM is a Hindi film which seeks to highlight the potential conflicts that can stem from lack of water scarcity, and the importance of water conservation. The film also highlights how measures like rainwater harvesting and using less water intensive crops can go a long way in saving water. Through the partnership, we undertook a series of activities involving both filmstars and politicians to help highlight issues around water conservation and get people thinking, talking, and acting on them.

### Introduction

India is already feeling the impacts of water scarcity. More than 100 million people in India are living in places where water is severely polluted. Out of the 632 districts examined by India Water Tool (IWT) to determine the quality of ground water in 2015, only 59 districts had water safe enough to drink. Groundwater levels are declining across India. Of the 4,000 wells captured in the IWT showing statistically significant trends, 54 percent dropped over the past seven years, with 16 percent declining by more than 1 meter (3.2 feet) per year. Data from the Central Water Commission shows that water levels in the 91 major reservoirs in the country are currently at just 23 per cent of their storage capacity. Reservoirs of the west and south India have the least water, compared to normal levels. The 31 big reservoirs in the five southern states have only 15 per cent of their normal water, while the 27 in Maharashtra and Gujarat have just 18 per cent.

*Kaun Kitney Paani Mein* (KKPM) is a Hindi feature film directed by Nila Madhab Panda, set in a hypothetical village in India facing severe water scarcity. The film sought to highlight the conflicts stemming from water scarcity and the importance of water conservation. It was released on August 28, 2015 across the country. The film got an average three star rating and was appreciated for tackling serious issues through an unconventional story. The Indian film industry, known as “Bollywood”, had around 1,900 million cinema admissions in 2014. The partnership started when One Drop Foundation approached WaterAid to be their partner in India and help promote the film.



## EQUITY NON-DISCRIMINATION AND INCLUSION (ENDI)

### Citizen Empowerment & Inclusion

Since WaterAid focuses on access to safe drinking water for everyone, everywhere and Bollywood and its celebrities have a wide reach and influence on people in India, WaterAid India partnered with the Bollywood film *Kaun Kitney Paani Mein* (English title: *In Troubled Waters*) to highlight issues of water scarcity and water conservation in India.

#### Context, aims and activities undertaken

WaterAid India undertook a series of activities to promote the film, water conservation issues and use star power to get people talking about it. The outreach consisted of a series of activities:

- Social media push through messages on water conservation and how KKPM promotes the idea of water conservation.
- Twitter chat named as #paanichat with the lead actor of the film Kunal Kapoor to highlight the issue in the digital realm and create a buzz.<sup>2</sup>
- Social media contest for exclusive premiere passes.
- A special red carpet premiere of the film in New Delhi with the Delhi Chief Minister and Delhi Deputy Chief Minister attending the screening.
- We also partnered with India's leading online retailer Snapdeal. As part of this initiative, Snapdeal and WaterAid encouraged its customer base/supporters to buy and donate soap to WaterAid for use in our school WASH projects. There is also an insert at the end of the film urging viewers to donate soap to WaterAid through Snapdeal.



#### Main results and lessons learnt

The #paanichat (Twitter Chat) reached 367,701 accounts and had 6,457,763 impressions. The chat was able to bring to the forefront issues around water scarcity in India and why it is time to start thinking about water conservation. The Bollywood touch to the chat made the Twitter chat more reachable to the people and we were able to engage people quite effectively. This was one of the first Twitter chats in WaterAid's history.

## EQUITY NON-DISCRIMINATION AND INCLUSION (ENDI)

### Citizen Empowerment & Inclusion



**HANDWASHING with SOAP**

before eating or preparing food and after using the toilet can reduce the risk of **diarrhoea** by more than

**40%**

Donate soap to WaterAid! [www.snapdeal.com/offers/kkpm](http://www.snapdeal.com/offers/kkpm)

**ONE DROP** **KAUN KITNEY PAANI MEIN** **WaterAid** **snapdeal**

A One Drop Foundation initiative

The premiere which was attended by the cast of the film as well as the Chief Minister Arvind Kejriwal and Deputy Chief Minister Manish Sisodia of Delhi and over 400 people made the water issue more visible in the political circles. Both of them raised their concerns about the declining levels of water in the country and why it is time we must start thinking about it. The video by Chief Minister of Delhi Arvind Kejriwal calling for water conservation got around 5,000 views online.

The goal of the partnership was to effect changes in how water is managed at household and higher levels.

While the film helped people understand the issue of water crisis and conservation and drive conversation around this important issue, One Drop Foundation and WaterAid India are currently exploring the commissioning of a focussed research study to better understand the impact of the film in effecting long term and lasting behaviour change.

The Snapdeal partnership gave us the opportunity to push the need for handwashing to prevent diarrhoeal deaths to an urban audience. A set of special images and infographics were designed to ask the users to donate soap which were also used by Sanpdeal for promotion. Sanpdeal has around 3,661,333 likes on its Facebook page and 192K followers on Twitter. While people were donating they were also being sensitised on the need and importance of handwashing.

The partnership was one of a kind within the organisation and the use of an upcoming Bollywood film helped us create a buzz and get people talking about water issues.



**HANDWASHING with SOAP**

could protect

**1 out of 3** with diarrhoea

**1 out of 5** with respiratory infections

Don't Wait. Donate soap to WaterAid. [www.snapdeal.com/offers/kkpm](http://www.snapdeal.com/offers/kkpm)

**ONE DROP** **KAUN KITNEY PAANI MEIN** **WaterAid** **snapdeal**

A One Drop Foundation initiative

### Conclusions and Recommendations

The partnership with Kaun Kitney Paani Mein was an unique experiment of a non-profit joining a film and its crew and bringing on board political leaders together to raise awareness of the importance of water conservation and security.

We are now working with the producers of the film One Drop Foundation to commission a study on the impact the film has on people in terms of changing behaviours on water conservation.

### Acknowledgements

## **EQUITY NON-DISCRIMINATION AND INCLUSION (ENDI)**

### **Citizen Empowerment & Inclusion**

We would like to thank Nila Madhab Panda, Director, Kaun Kitney Paani Mein, One Drop Foundation and their entire team, colleagues at WaterAid India for their support with the partnership.

#### **References**

- Shiao Tien, Maddock Andrews, Carson Chris and Loizeaux Emma (2015) '3 Maps Explain India's Growing Water Risks', World Resources Institute. For more details see: <http://www.wri.org/blog/2015/02/3-maps-explain-india%E2%80%99s-growing-water-risks>
- 'Brief Note on Storage Status of 91 Reservoirs in the Country'. Central Water Commission (2016). For more details see: [http://59.180.242.253:83/DocumentUploadRoot/DocumentId\\_4926/17.03.2016\\_CWC\\_bull.pdf](http://59.180.242.253:83/DocumentUploadRoot/DocumentId_4926/17.03.2016_CWC_bull.pdf)
- Rohit Vats (2015), 'Kaun Kitney Paani Mein review: Deserves praise for efforts', Hindustan Times. For more details see: <http://www.hindustantimes.com/movie-reviews/kaun-kitney-paani-mein-review-deserves-praise-for-efforts/story-YLjaZOtEawtQHCY7MHoXHO.html>
- Saibal Chatterjee (2015), 'Kaun Kitney Paani Mein Movie Review', NDTV . For more details see: <http://movies.ndtv.com/movie-reviews/kaun-kitney-paani-mein-movie-review-1168>
- Film industry in India - Statista Dossier (2014). For more details see: <http://www.statista.com/statistics/316824/cinema-admissions-india/>

EQUITY NON-DISCRIMINATION AND INCLUSION (ENDI)

Citizen Empowerment & Inclusion

# Closing the Equity and Inclusion Gap for Water and Sanitation: Lessons from Wakiso Health Improvement Project for Elderly and people with disabilities in Namayumba and Kakiri Sub-county, Wakiso District

Type: Short Paper

Authors : Dennis Nabembezi , Head of programmes, Voluntary Action for Development [VAD], Uganda, [dnabembezi@gmail.com](mailto:dnabembezi@gmail.com) +256-772-568-359

## Abstract/Summary

About 1.5 million Ugandans are above 60 years and another 6 million are Persons With Disability (PWDs)<sup>40</sup>. The Constitution of Uganda provides to promote and protect rights of PWDs and other marginalised groups like elderly including the right to accessing safe water and sanitation. The elderly and PWDs have continued to face extreme conditions of lack of access to Water, Sanitation and hygiene (WASH) services. There are no deliberate technological designs and approaches to improve access to WASH services to these populations. To address this challenge and promote awareness of equity and inclusion for WASH services in Uganda, Voluntary Action for Development (VAD) a local Non Government Organisation (NGO)with financial support from AidLink(An Irish Government Development Agency) implemented the Wakiso Health Improvement Project to provide access to WASH services for PWDs and elderly in Wakiso District

## Introduction

The Government of Uganda is committed to increasing access to safe water supply in rural areas from 65 percent in 2012/13 to 79 percent in 2019/20 and in urban areas from 77 percent in 2012/13 to 100 percent in 2019/20<sup>41</sup>. The ministry of water and Environment (2015) estimates that about 35% and 25% of Uganda’s rural population don’t have access to safe water and sanitation respectively. There are also disparity between districts, regions and populations including PWDs and the elderly (60 years above).

UNICEF (2014) estimates that about 1.4 million Ugandan children with disability don’t have access to safe water and sanitation<sup>42</sup> while the Uganda National Council for Disability estimates that over 5 million PWDs don’t have access to basic social services including water and sanitation. The Ministry of Water and Environment, Sector Performance Report (SPR) also don’t report both water and sanitation access for both elderly and PWDs under equity and inclusion indicators. There are also no deliberate attempts from Government, WASH Civil Society organizations (CSOs) and Development Partners (DP) to address this inclusion and equity challenge in the country.

The project trained 50 community masons to construct two hundred and fifty (250) -2,000 litre Rain Water Harvesting Jars (RWHJ), 250-two stance VIP latrines with a bath shelter, support guards, raised seats tailored to PWDS and elderly, 250 tippy taps and 250 dish racks. These facilities have improved access to WASH services to over 250 PWDs and elderly households, serving over 1,250 people directly and about 106 households (500 people) for water from the PWDs and elderly tanks during rainy seasons and about 5,917 households (27,813) people with sanitation and hygiene promotion services.

<sup>40</sup>National Population and Housing Census, 2014

<sup>41</sup> Second National Development Plan 2015/16 – 2019/20

<sup>42</sup>Situational Analysis on the Rights of Children with Disabilities in Uganda, UNICEF 2014

## EQUITY NON-DISCRIMINATION AND INCLUSION (ENDI)

### Citizen Empowerment & Inclusion

#### Description of the Case Study – Approach or technology

The Wakiso Health Improvement Project is a three year (2013-2016) WASH access improvement intervention for PWDs and elderly targeting two Sub-counties of Namayumba and Kakiri of Wakiso District in central Uganda. Wakiso District is the most populous district in Uganda with about 2 million people of which over 84,000 people are elderly persons and 120,000 PWDs<sup>40</sup>. The recent SPR (2015) estimates that about 62% and 71% of the district population have access to safe water and sanitation respectively though with some disparities between sub-counties and key populations including PWDs and elderly who are the most affected with this lack of access.

The project was implemented by Voluntary Action for Development (VAD) a local NGO founded in 1996 with her core business in promotion of water and sanitation with financial support from AidLink (An Irish Development Agency). The project adopted a community based support system working through already existing community structures to promote access to WASH services for the elderly and PWDs. The project is conceptualised on the community support where able bodied members of the community come together to support those who can’t support themselves and putting the community at risk of WASH related diseases through poor sanitation and hygiene.

The project started with a community mobilisation meeting to sensitize the community about the dangers of open defecation, safe water chain, and wastemanagement, hand washing, personal hygiene including menstruation hygiene. During the sensitization, the elderly and PWDs were identified as key groups contributing to major contamination through poor sanitation and hygiene including Open Defecation (OD).

The community agreed on key action points including household sanitation and hygiene improvement through participatory hygiene and sanitation transformation (PHAST) as well as supporting the elderly and PWDs with sanitation and hygiene facilities at household level to stop OD. On achievement of 100% sanitation coverage and Open Defecation Free (ODF) status the community was rewarded with a water source.

To promote hygiene and sanitation improvement at community level, the project trained community monitoring teams (CMTs) five at each village to promote and monitor hygiene and sanitation promotion. The CMTs were supported with PHAST tools, WASH monitoring logbooks where they record monitoring data including households which have constructed, latrines, drying racks, bath shelters, observing a safe water chain and hand washing to mention. The CMTs were also supported with a bicycle to help in transportation during WASH promotion and monitoring. The monitoring data was submitted to both VAD and the District through the District Water Office and to the MWE, SPR and the NGO SPR.

To improve access to WASH services for the elderly and PWDs, the project trained community masons and equipped them with tools to construct appropriate latrine facility [with an access ramp, support guards, raised seats and wide size-stance to allow turning of a wheel chair], drying rack, bath shelter and 2,000 litre water jar with a First Flush Device (FFD). The project during construction provided all the cement, iron bars, doors, iron sheets, bricks, gutters, fittings and subsidised the labour cost for construction. The community though the CMTs mobilized local materials to construct the drying racks, Hand Washing Facilities (HWFs) and food for the masons during construction. The CMTs and the community also constructed the drying racks, tippy taps and refuse pits. The beneficiaries (PWDs and elderly) provided a roof catchment, food for the labours and accommodation where possible.

#### **Results:**

To date the project has constructed 250 two-stance latrines with a bath shelter, support guards, access lamp and a raised seat, 250 -2,000 litre RWHJs fitted with a FFD, 250 HWFs, 250 drying racks, trained and equipped 50 community masons, trained and equipped 250 CMT members to promote sanitation and hygiene improvement at house hold level.

## EQUITY NON-DISCRIMINATION AND INCLUSION (ENDI)

### Citizen Empowerment & Inclusion

#### *Beneficiaries:*

Beneficiary category	Numbers reached		
	Male	Female	Total
<b><i>Direct beneficiaries [250 households]</i></b>			
Persons with disabilities (PWDs)	65	73	138
Elderly (60 years and above)	52	60	112
Children (1-17 years)	278	325	603
Adults (18-59 years)	179	218	397
<b><i>Indirect beneficiaries for water [106 households]</i></b>	235	265	500
Direct beneficiaries for sanitation and hygiene promotion [5917 HHs]	13,072	14,741	27,813
<b>Totals</b>	<b>13,881</b>	<b>15,682</b>	<b>29,563</b>

#### *Sustainability*

The locally trained community masons and CMTs will continue to construct, undertake operation and maintenance of sanitation facilities as well as sanitation and hygiene promotion since they are located in the target community and likely not to leave. Community ownership and contribution: Local materials including labour to construct WASH facilities were mobilised through community initiatives and readily available in the community which is likely to sustain the facilities for the elderly and PWDs.

#### *Challenges:*

The success of the intervention is highly dependent on the spirit of voluntarism especially for the masons and the CMTs who contribute most of the labour to the project. There is a fear that in future their efforts regarding WASH promotion and monitoring may go down. The project was only able to support a few PWDs and elderly compared to the high number in the district due to limited resources hence leaving many others with limited or no access to WASH services. Further still, for PWDs and elderly to benefit from the project had to have a roof catchment which can support rain water harvesting which made many of them miss out.

#### *Impact and lessons learnt*

The project has raised awareness of the equity and inclusion challenges faced by PWDs and elderly in accessing WASH services through the National and NGO SPR where a case study about the project has been documented and plans are underway to present it as a recommendation to the National Joint Sector Review meeting later this year. There has been improved health and dignity for PWDs and elderly through access to appropriate WASH services at household level and at community level due to reduced OD practices.

#### *Conclusions and Recommendations*

If Uganda and Africa in general is to achieve National Development Plan goals for WASH and the Sustainable Development Goals for WASH [water and sanitation for everyone and everywhere], there is need to adopt inclusive planning, approaches and technologies like RWHJ and tailored PWDs latrines to bring services to people who can't move a distance and often excluded from WASH service delivery.

#### *References*

- 1) Government of Uganda (2014), National Population and Housing Census, Final report
- 2) UNICEF (2014), Situational Analysis on the Rights of Children with Disabilities in Uganda
- 3) Government of Uganda (2016), Second National Development Plan 2015/16 – 2019/20
- 4) Uganda National Council for Disability (2015), State of disability in Uganda.

Contact Details

Name of Lead Author: Dennis Nabembezi

**EQUITY NON-DISCRIMINATION AND INCLUSION (ENDI)**

**Citizen Empowerment & Inclusion**

Email: [dnabembezi@gmail.com](mailto:dnabembezi@gmail.com)

Name of Second Authors:

- 1) Benedict Male
- 2) Harriet Nabunnya

EQUITY NON-DISCRIMINATION AND INCLUSION (ENDI)

Citizen Empowerment & Inclusion

# Capacity building to couples for community and women empowerment and effective and efficient implementation of WASH approaches: The case of the Amhara Integrated Rural Water, Sanitation and Hygiene Project, Ethiopia

Type: Short Paper

## Authors

Nigussie Mihretu; Gender & Capacity Building Officer, AIRWASH Project; HELVETAS Swiss Intercooperation; Ethiopia; [Nigussie.Mihretun@helvetas.org](mailto:Nigussie.Mihretun@helvetas.org) ; +251 938840755

Ewnetu Gedif; Project Manager; AIRWASH Project; [Ewnetu.Gedif@helvetas.org](mailto:Ewnetu.Gedif@helvetas.org) (co-author)

## Abstract/Summary

A water, sanitation & hygiene (WASH) project in the rural areas of Amhara Region, Ethiopia has introduced WASH specific capacity building activities for couples. The objective is to enhance active and meaningful participation of the community, and in particular of women, in WASH related activities. Capacity building elements included training sessions, an experience sharing visit to a gender sensitive community and monthly community discussions. As a result, changes of attitude and behaviour among the couples were observed. These went beyond pure WASH related aspects, including abolishment of domestic violence among the participating couples. Besides, the trained couples acted as promoters of good WASH practices. This piloted approach of capacity building of couples can bring significant changes in ensuring gender equality and in sustaining promoted WASH approaches in rural areas. The approaches applied in this project have been replicated in other two woredas / districts.

## Introduction

Ethiopia's coverage of clean water supply for urban areas was 93 %, while the access to potable water in rural areas is 49 % only (UNDP MDG Report 2014 Ethiopia). "Water and sanitation related diarrhoea is among the top three causes of all deaths in Ethiopia, and Amhara region is one of the regions that have faced this life threatening challenge for many years" (Tilahun et al, 2010). Although women and girls are primary users, providers and managers of water at their households, their access to information, training and decision making concerning WASH is very low. Women's multiple roles, responsibilities and heavy workloads leave them with no space for involvement in influential decision making related to the development of water and sanitation resources. (Ministry of Water Women's Affairs Department, 2005). The purpose of this short paper is to present capacity building activities with couples, which aim to improve the empowerment of women and the community through the effective and efficient implementation of WASH approaches. These capacity building activities have been implemented by HELVETAS Swiss Intercooperation under its Amhara Integrated Rural WASH (AIRWASH) project.

## Context, aims and activities undertaken



## EQUITY NON-DISCRIMINATION AND INCLUSION (ENDI)

### Citizen Empowerment & Inclusion

Like in most villages of Amhara region, Ethiopia, women in Meha Kebele experienced drudgery of fetching water for domestic purpose. They suffered from sanitation and hygiene related diseases, lived in a highly patriarchal society, and were subjected to painful domestic violence, which was very common among the villagers and often related to issues around water supply and management for household consumption. Hence, women suffered heavily due to issues related to clean and safe water supply as well as sanitation and hygiene. It was also their responsibility to care for their children, as well as for elderly people and other family members. The people of Meha Kebele were vulnerable to malaria and other water borne parasites and diseases like amoebas and typhoid.

Compared to unmarried women, married women, restricted by their husbands, have less access to information, regarding their rights to clean and safe water, adequate sanitation and hygiene, and gender equality. Due to the traditional gender roles such as managing household chores, care for elder relatives and children, married women are often excluded from information, which occasionally may be passed on to them via their husbands. The root cause of this problem is patriarchy. As a result, married women do not understand their rights to WASH services, but consider them a gift from the government and/or other institutions. Subsequently, their participation in WASH activities is minimal. All these gender gaps identified in Meha village can be found in other villages of Amhara region as well as in most parts of Ethiopia.

Taking this contextual situation from Meha village into account, the objective of the AIRWASH project's capacity building approach was to empower married women and to ensure the sustainability of WASH services through women's active participation in planning and implementation and management of these services.

In order to create a conducive situation by changing the patriarchal attitude for married women who have relatively less access to information than unmarried women, and to empower women, the project opted for addressing with its capacity building efforts households rather than individuals and therefore invited couples, husbands and wives, to the various capacity building activities.

In consultation with the Woreda (district) and Kebele partners Meha village was selected and 26 couples, 3 single women and 3 facilitators were invited. This WASH capacity building was the first of its kind in the history of the Amhara region and consisted of training sessions, experience sharing, an exchange visit and community discussions. The events were arranged at times and places which were favoured by the women. The contents of the training included gender issues, gender mainstreaming in WASH, water points management, sanitation and hygiene issues, as well as social inclusion. Soon after the training, a one-day experience sharing visit was arranged to Awuramba, a nearby community well known in the region and even in the country for ensuring gender equality and social inclusion. This experience sharing visit enabled them to grasp lessons on gender equality issues, waste disposal and management, water structure management, improved latrine building, installation of hand washing facilities next to latrines, and on care and support to elderly and disabled people. Refresher trainings were given twice to these participants so as to strengthen their way of using and managing WASH services. There has been close monitoring and follow-up by the Woreda partners and the project staff.

Later, the project replicated the approach in two more villages in other Woredas. Unlike in Meha village, the project ensured that most villagers could attend the training, experience sharing and community discussion forums.

### Main results and lessons learnt

The chosen capacity building approach brought wives and husbands to the centre of an equally levelled playground to face and experience gender equality, sanitation and hygiene, and water point management equally side by side. It also disproved the belief women could get information only as a trickle via their

## EQUITY NON-DISCRIMINATION AND INCLUSION (ENDI)

### Citizen Empowerment & Inclusion

husbands. Besides, the participants fully transferred the lessons learnt from the exchange visit into practice. They attended together community meetings which helped especially the women to develop self-confidence. As their self-confidence grew, their active involvement in all WASH activities increased dramatically, which in the end resulted in increased ownership of WASH services.

At operational level, the results obtained are illustrated as follows: In collaboration with the community, three hand dug wells were built by the project. The villagers, especially the trained women fully engaged in site selection, technology choice, in light work during the construction of the water schemes and in mobilizing construction inputs such as sand, cement and gravel. Once the work was completed, women also contributed to operation and maintenance activities related to the newly constructed water points. Today, three of the five members of the Water, Sanitation and Hygiene Committees (WASHCO) are women. The trainings and experience sharing visit helped them to enhance their participation at all levels of WASH activities and fully discharge the WASHCO's duties and responsibilities. Besides, the trained couples took a lead role in constructing pit latrines, involvement in household care and management, and in sharing household chores between husband and wife. Together with fellow villagers they constructed a community hall to conduct monthly meetings where they discussed issue like sanitation, hygiene, gender division of labour, and use and management of water schemes.

To summarise the results:

- Once shy, the women now are speaking about their rights to water, sanitation and hygiene, as their self-confidence increased. To mention a quote from one married woman: "Before the project's intervention to our village, we were ignorant on many things. Women suffered, they didn't know their rights and were unable to stand for their rights. But after the project's training, experience sharing visit and community discussions, everything has changed and we are leading a better and peaceful life thanks to the project."
- 26 trained women are able to get information through training, meetings and events in the same manner as their husbands;
- With regard to inclusiveness, 14 socially and economically disadvantaged persons (10 women;4 men) have got access to information on WASH practices and services;
- Once passive receivers, women have become active participants and actors regarding WASH activities, including participation in WASH committees. The trained persons participated in site selection, technology selection, participating in light works during construction, community audit and monthly community discussions. 9 women WASHCO members played an active role in mobilizing women to participate in the various WASH activities;
- The couple training helped men and women from 26 mixed households and 3 women headed households to understand gender division of labour as a socially constructed issue, which therefore can be changed. The training, the experience sharing visit to Awuramba community and community discussions enabled 26 men to participate in helping wives in household chores, such as fetching water from hand dug wells, caring children, cleaning activities which reduced the burden of women and girls. Women expressed their views freely in community meetings and decision making and mutual understanding at household level improved. Besides, domestic violence which was common before the training stopped (this data is gathered through discussions with model villagers);
- 150 households, who did not participate in this particular training, received training from the trained couples and started replicating good practices such as construction of pit latrines, but also setting up fuel saving stoves and improving management at household level.

## EQUITY NON-DISCRIMINATION AND INCLUSION (ENDI)

### Citizen Empowerment & Inclusion

- They started to make body washing/taking shower once a week at family level at 29 households.

Lessons learnt from this capacity building approach involving couples are:

- The training helped especially married women to get the same access to information, education and technology regarding WASH services as for their husbands; this was unusual and new, and enabled the women to develop self-confidence and increase their stake in WASH;
- As married women participated together with their husbands in this capacity building process, they together fully understood the advantages and disadvantages of sanitation and hygiene, and management of water points, which helped for effective and efficient implementation of the community's WASH activities;
- Couple capacity building interventions are best for men and women to understand traditional gender division of labour as a social construct, which can be changed through mutual decision making and respect at household level as well as through awareness raising at community level;
- From the planning of WASH services to the completion stage, the equal participation and contribution of women and men guaranteed the sustainability of the WASH services;
- To get women's active and full contribution for WASH activities in the village, taking into consideration time and places that suit women for each training, meetings and community discussions are essential.

Some challenges however remain. High levels of illiteracy that are prevalent in the villages and patriarchal attitudes of the community limited the pace of exercising the approach within a reasonable timeframe. Although continuous follow up, exchange visits and sensitization sessions made the approach a reality, problems occurred in the progress of the introduction and dissemination of the approach. Hence, continuous support and follow-up meetings, and community discussions are essential for the villagers to ensure sustainability of their achievements.

There are also issues and to some extent concerns when looking at the potential up scaling. The approach chosen was rather resource intensive (ETB 1200, equivalent to USD 55 per participant) with lots of meetings and exchanges, and it required well qualified staff as trainers and facilitators. While replicating it in two more villages, the costs came down to about ETB 1000 per trainee. Still, the amount is relatively high when looking at government resources. Therefore, it has to be seen to which extent these resources can be made available through the governmental WASH support structures and to which extent the required facilitation and training capacities can be built within the Government.

For the AIRWASH project, continuing close collaboration and partnership with the local government partners is mandatory in order to strengthen the approach, reducing costs and promoting its up scaling. Promotion of the approach will include the preparation of guidelines for the governmental staff at Woreda level as well as capacity building of these Woreda staff.

### Conclusions and Recommendations

The capacity building approach whereby couples are given centre stage, and as demonstrated by the AIRWASH project in Ethiopia, broke the glass ceiling and brought the women as key WASH actors to the centre. The capacity building interventions enhanced women's knowledge about their rights to clean, safe and adequate water, improved sanitation and hygiene practices, water resource management, as well as gender equality and social equity. The representativeness of the village could serve as a basis to scale up the approach by others throughout the Amhara region as well as in other parts of Ethiopia. To disseminate this approach, the following recommendations to different actors are suggested:

## EQUITY NON-DISCRIMINATION AND INCLUSION (ENDI)

### Citizen Empowerment & Inclusion

#### Government

- Government WASH actors should endorse this practice and replicate it in other WASH activities implemented by the government and it should coordinate other NGOs to replicate the good practice.
- Government WASH actors should get involved in or at least follow up the further development of the approach.
- Government WASH actors should encourage stakeholders to adopt and clearly highlight the approach in annual rural WASH plans and its implementation.

#### NGOs

- NGOs working in the WASH sector should replicate this good practice in order to ensure sustainability, gender equality and social development.

#### AIRWASH Project / HELVETAS

- Should create awareness on the approach, both formally and informally.
- Should advocate the approach for scaling up at different levels.

#### Acknowledgements

The authors would like to thank the entire AIRWASH project team as well as the community in Meha village for all their support, collaboration and active participation in the framework of the project which led to the experience summarized in this paper. Thanks also go to HELVETAS Swiss Intercooperation in general and in particular, to Dr. Agnes Montangero, Team Leader for Water & Infrastructure at Head Office for her support on technical aspects and to Dr. Felix Bachmann, Country Director of HELVETAS in Ethiopia for his encouragement and suggestions while shaping the paper into its final form.

#### References

- Ministry of Water Resources Women's Affairs Department (2005) Gender Mainstreaming Field Manual for Water Supply & Sanitation Projects In collaboration with Ethiopian Water Resources Training Centre and Japan International Cooperation Agency (JICA).  
<http://www.mowr.gov.et/index.php?pagenum=10>
- Tilahun et al. (2010) Assessment of Water Supply and Sanitation in Amhara Region, Learning and Communication Report; Bahir Dar University, Ethiopia  
[http://soilandwater.bee.cornell.edu/Research/international/docs/wateraid-finalreport\\_Ap](http://soilandwater.bee.cornell.edu/Research/international/docs/wateraid-finalreport_Ap)
- UNDP (2015) MDG Report 2014 Ethiopia; Assessment of Ethiopia's Progress towards the MDGs; Addis Ababa; Ethiopia  
<http://reliefweb.int/report/ethiopia/ethiopia-millennium-development-goals-report-2014>

EQUITY NON-DISCRIMINATION AND INCLUSION (ENDI)

Citizen Empowerment & Inclusion

# Co-production of community managed operations and maintenance: taking a critical view on rural water schemes in Ethiopia

Type: Long Paper (up to 6,000 words)

**Authors:** *Linda Annala*, Doctoral candidate, Hanken School of Economics, Finland, [linda.annala@banken.fi](mailto:linda.annala@banken.fi), +358503765720; *Arto Suominen*, Team Leader, Community-Led Accelerated WaSH in Ethiopia, [arto.suominen@gmail.com](mailto:arto.suominen@gmail.com)

## Abstract/Summary

In this paper we take a critical view on community managed operations and maintenance of rural water schemes and examine the responsibilities and power relations produced within community management in the Ethiopian water sector. In particular, we focus on the ways in which the co-production of public services is practiced in community managed operations and maintenance processes. Through analyzing 53 interviews with district officials, community water committee members and local suppliers, and the recently drafted National Rural Water Supply Operation and Maintenance Management Strategic Framework we illustrate how the macro-level policies on community managed operations and maintenance and institutional co-production can be enacted in a more micro-level construction of power relations. In the study we identified several responsibilities that were shared by several organizational levels, and examined how they were embedded in the organizations’ formal and informal hierarchies. By taking a critical approach to community managed operations and maintenance, we have also been able to explore some unwanted consequences of emphasizing community management in rural water supply.

## Introduction

Community managed rural water supply has been a celebrated approach in global development policies for the past few decades. It has been underlined as a key determinant for sustainable rural water supplies and has gained widespread popularity among donors and governments. As part of the concept, community managed maintenance and operations (O&M) has been praised both for its efficiency and participatory approach as it aims at ensuring that end users who rely on the water scheme – and therefore have strongest motivation to keep it working – have the skills and funds to do the necessary maintenance and repairs themselves. The key mechanism is “ownership” creation, through which people are made to feel they have both the responsibility and the power to act (Chowns, 2015). Community management grew from the first International Drinking Water Supply and Sanitation Decade of the 1980s. During the decade, water schemes were constructed at rapid rates, but governments lacked the human capacity and financial resources to manage and maintain these new infrastructures. The solution became then to encourage community ownership of water schemes, including their long-term operations and maintenance (Schouten, 2006). Viewing community management as a panacea for sustainable rural water services has since then triggered an increasing amount of skepticism. Sustainability still remains a question mark as various water supplies continue to become non-functional before their design periods. It has been argued that in order to remain sustainable, community management systems require ongoing support from an overseeing institution to provide motivation, monitoring, participatory planning, capacity building, and technical assistance (see e.g. Carter et al., 1999; Harvey and Reed, 2006).

In this paper, we take a critical view on community managed operations and maintenance (O&M) of rural water supply. The term “critical” is used to question the current beliefs and assumptions (Alvesson and Deetz, 2000) and not to find fault in the ways in which practices manifest themselves. Instead of asking what community management is and how it can be improved for the benefit of end users or governments, we are interested in community managed O&M as an overarching means of co-producing a

## EQUITY NON-DISCRIMINATION AND INCLUSION (ENDI)

### Citizen Empowerment & Inclusion

public service, and in the consequences of the embedded power relations for the responsibilities of people working with O&M in practice. The following research questions are posited: How is community managed O&M co-produced along the various actors? What kind of roles can be distinguished in the discourses surrounding community managed O&M?

In investigating these questions, we take the theoretical lens of institutional co-production to analyze the power relations that result in sharing responsibilities between different groups of people. In order to provide conceptual clarity for this paper, we have defined the key concepts in the text box below.

Co-production	Co-production describes “processes through which diverse inputs are contributed by individuals and organizations that are not part of an official government agency primarily responsible for producing a particular public good or service” (Ostrom, 2013, p. x)
Empowerment	Empowerment is defined as an increase in access to the eight bases of social power as identified by Reed and Reed (2009): defensible life space, skills and knowledge, surplus time, appropriate information, social networks, social organization, instruments of work and livelihood, and financial resources.
Discourse	Discourses constitute social practices, speech and texts through which meaning is constructed. Discourses can be viewed as social boundaries that define what can and cannot be said about a topic. From epistemological and ontological perspectives, knowledge is constructed both in saying and in doing, and can be thought of as ‘sets of socially and historically constructed rules designating ‘what is’ and ‘what is not’ (Carabine, 2001). In other words, discourse can be seen as ‘a way of representing knowledge about a particular topic at a particular historical moment’ (Hall, 1992, p. 291)

Institutional co-production is characterized by a mix of activities that both public agents and citizens contribute to in the provision of public services. The former are involved as professionals or “regular producers”, while “citizen production” is based on efforts of individuals or groups to enhance the quality and/or quantity of services they receive (Parks, et al., 1981; Brudney and England, 1983; Ostrom, 1999). The topic of institutional co-production will be further discussed in the following sections.

The aim of our paper is twofold: First, through qualitative analysis of interviews conducted with Water, Sanitation and Hygiene Committee (WASHCO) members, district officials, and other actors as well as the recently drafted National Rural Water Supply Operation and Maintenance Management Strategic Framework (O&M Strategic Framework from here onwards), we have aimed at mapping the discursive power relations prevailing in community managed O&M processes in Ethiopia. Secondly, through this lens we have come to illustrate five different distinctive roles within the co-production of O&M of rural water supply in Ethiopia. These roles highlight the interesting tensions between social empowerment and decentralization of responsibilities which will be further discussed in the following paragraphs.

### Context, aims and activities undertaken

#### Theory

In this section we discuss the theoretical underpinnings of our paper. Moving from co-production of public services to the theoretical lenses around power relations, we wish to create an understanding on the discourses that surround community managed O&M in rural water supply provision.

#### *Institutional co-production of public services*

## EQUITY NON-DISCRIMINATION AND INCLUSION (ENDI)

### Citizen Empowerment & Inclusion

In order to view power relations surrounding community managed O&M in rural water supply, we have chosen institutional co-production as our theoretical lens. Institutional co-production can be seen as a continuation of a new governmental order that is characterized with a “fragmentation of authority, the increasing ambiguity of borders and jurisdictions; and the blurring of lines between the public and private sphere” (Kobrin, 2009 p. 350). The concept provides an abstract perspective through which the production of public services can be separated between governmental actors and citizens. Through such a division of production activities, also responsibilities come under change. Typically, and according to the social contract theory, citizens and the government are in a reciprocal relationship: government is trusted to provide public services such as education, health care and water supply against the citizen’s labour and tax payments. In the context of many countries in the global South, however, this social contract is breaking as many services are either privatized or under-funded. Thus responsibilities are being reorganized and citizens have been encouraged to take on new roles in public service provision. Such new roles may include monitoring of public services through participatory observation (Wehn and Evers, 2015), or active participation in producing public services, such as cooperative child care (Pestoff, 1998).

Typically, co-production is seen as a dyadic relationship between the citizen and the state (see e.g. Hilton and Hughes, 2013). What researchers of co-production have been recognising is that public services rely as much upon the unacknowledged knowledge, assets and efforts of service ‘users’ as the expertise of professional providers. The Nobel prize winner Elinor Ostrom studied the polycentricity of police functions in the U.S., showing how the public service was co-produced jointly by citizen producers and professionals. Ostrom and Baugh (1973) concluded that in order to function properly, police needed the community as much as the community needed the police to fulfill the public service. The informal understanding of local communities and the on the ground relationships they had developed with police officers helped to keep crime levels down.

Joshi and Moore (2004) suggest two different sets of motivating forces for institutional co-production: inefficient provision of services by the state; and the complexity and variability of the context for which the public service is targeted. These sets of drivers lead to the continuous re-negotiation of production activities of public goods among the different actors. The technologies that are utilized in delivering the public good play a crucial role whether production activities of a service can be shared among both regular and citizen producers (Pestoff, 2013). In the dominant discourse, institutional co-production is viewed as a positive development in the provision of public services (Voorberg et al., 2014). Such studies argue for institutional co-production promoting participative democracy (Ostrom, 2000; Fung, 2004); contributing to greater satisfaction of users to services (Brandsen et al., 2013); and ensuring the development of service quality in public services (e.g. Parks et al., 1981). This positive portrayal of institutional co-production sees people as active agents, growing their capacity and confidence through active participation in service provision. We label the positive aspects associated with co-production as empowerment of citizens. Empowerment is a wide-ranging area of research and practice that can be approached from a multitude of perspectives.

In contrast to this literature, there is a growing criticism towards the celebrated forms of institutional co-production. With a shift towards institutional co-production it is suggested that new space is created for private market-based solutions to fill the role of the governmental production (Annala et al., 2016). Vancoppenolle and Verschuere (2013) suggest the involvement of private organizations in public service provision through co-production threatens public accountability. Moreover, institutional co-production seems to encourage heterogeneity due to its possibilities for customization, according to Brandsen et al. (2013). Heterogeneous services may then risk public services becoming dependent on social class or geographical area. Paradoxically, such heterogeneity may also be a source of innovation in public services (Adner and Levinthal, 2001). In particular, it has been argued that institutional co-production increases fragmentation in the provision of public services (Brandsen et al., 2013) and blurs the roles and responsibilities of the different actors. Such fragmentation is regarded a consequence of shifting the responsibilities towards end users who possess heterogeneous means to co-produce the public services. Harrison and Waite (2015) further conclude institutional co-production to be a double-edged sword: for

## EQUITY NON-DISCRIMINATION AND INCLUSION (ENDI)

### Citizen Empowerment & Inclusion

some it can be value-enhancing and empowering, whereas for others it can be value-destructing and disempowering. Further criticism notes how co-production places additional demands for people using the services, and contributing to citizen burden, and decentralization of responsibilities to citizens (O’Malley, 2008).

Literature on co-production rarely emphasizes the power relations among the co-producers, and what it means for the different roles and individuals to be part of institutional co-production. Our paper aims to extend the view through analyzing discourses in the institutional co-production of operations and maintenance of rural water schemes.

### Methodology

The study is based on a discourse analysis methodology. Discourse analysis is a competent way to understand power relationships in the institutional co-production of O&M of rural water supply.

### *Discourse, subjects and roles*

In public policy studies, the discursive view has often been used to reveal more critical aspects of political life and the governance of citizens. In this paper, we apply the concept of discourse to explore subject positions as embedded in power relations in the context of community managed O&M in rural water supply. We define a discourse as ‘a way of representing knowledge about a particular topic at a particular historical moment’ (Hall, 1992, p. 291). We understand the discourse on community managed O&M valuing the type of social empowerment of communities that is needed for long-term operational sustainability of water schemes in the absence of government resources. We use the singular term of discourse even though we acknowledge there are several discourses.

Discourses produce knowledge on phenomena (both objects and subjects), and thus form the ways in which social phenomena are understood within a specific historical context. Discourses constitute social practices, speech and texts through which meaning is constructed. Discourses can be viewed as social boundaries that define what can and cannot be said about a topic. From epistemological (referring to philosophy of science that studies the nature of ‘knowledge’) and ontological (referring to philosophy of science that studies the nature of ‘being’ and ‘reality’) perspectives, knowledge is constructed both in saying and in doing, and can be thought of as ‘sets of socially and historically constructed rules designating ‘what is’ and ‘what is not’ (Carabine, 2001). In other words, discourse can be seen as ‘a way of representing knowledge about a particular topic at a particular historical moment’ (Hall, 1992, p. 291)

The discourse on community managed O&M can be seen as formed through practices in which particular objects, i.e., water schemes are acted upon through agreed-upon practices. In a similar manner, particular subjects, i.e., users of water schemes, are identified and articulated in public organizations. Discourses are closely entwined with power relations, meaning that individuals as subjects are constructed and governed through discourses (Foucault, 2000). The types of discourses, on the other hand, reflect wider power relations on how a subject can and cannot act. Discourses construct subjects in two different ways: first, by creating ‘figures who personify the particular forms of knowledge which the discourses produce’ (Hall, 2001, p. 80) and, second, by providing a ‘place for the subject...from which its particular knowledge and meaning most make sense’ (Hall, 2001, p. 80). This means that people locate themselves in the position where the discourse appears most sensible and become produced as a subject within the discourse, its meanings, power and regulation (Hall, 2001). Thus, discourses produce subject positions, i.e. positions within a discourse from which individuals understand themselves and act. These positions define the structure of social rights for the actors involved (not legal but social rights); what they are expected, can, or cannot do (e.g., Davies and Harré 1990). However, people are not passively positioned by discourses but actively produce their own subjectivities by making use of them as resources in the construction of themselves (e.g., Alvesson & Willmott, 2002).



## EQUITY NON-DISCRIMINATION AND INCLUSION (ENDI)

### Citizen Empowerment & Inclusion

In order to better address the vocabulary of the audience of this paper, we have made a tactical decision to consolidate subjectivities in terms of roles. For the rest of the paper, we will focus on roles instead of subjectivities. This consolidation places the analysis on a more abstract but concrete level, but enables us to focus on the discourses that produce such roles.

#### *Context*

Universal access to safe water supply continues to remain a challenge in rural Ethiopia. According to the National WaSH Inventory (2011), the average national non-functionality of the rural water supply schemes was 25.5%, varying between 20% and 35% depending on the region. The dominant discourses around reasons for non-functionality of community-managed water supply point towards insufficient attention to capacity building (e.g. Koryang, 2011), lack of community ownership (e.g. Chowns, 2015) and a focus on project delivery which does not allow time for adequate training and follow up of post implementation (Carter et al., 1999). In the context of Ethiopia, the implementation and overall management of rural water schemes has been traditionally carried out by governmental bodies, donor and charity projects. Many of centralized top-down approaches, however, arguably fail to recognize the under-utilized local potential resources that could accelerate the implementation and management of water schemes (Asthana, 2003; CMP, 2015). This discourse shifted the emphasis towards rural communities during the last few decades, and currently - in line with the global trend of community managed water supplies - Ethiopia has included a community managed approach into its National Water Resource Management Policy (2001) and National WASH Implementation Framework (2011). The focus of this paper, however, is on the O&M Strategic Framework and the discourses surrounding community managed operations and maintenance.

#### *Empirical material*

The interview data collection took place in April and May 2013 in the Amhara region as well as in the city of Addis Ababa. In all of the nine districts, community managed O&M was being practiced, with more or less successful results. Altogether we interviewed 9 district water offices, 24 community organizations (WASHCOs, i.e. Water, Sanitation and Hygiene Committees), 10 spare part suppliers, and 5 NGOs. The rest of the interviews were done on the regional and federal level (see Table 1). In line with qualitative inquiry, sampling size was dependent on the saturation of the data. 11 of the interviews were conducted in groups of 1-13 individuals, with further 42 individual interviews. The interviews were conducted both in Amharic and English languages, supported by consecutive translation during the Amharic interviews. The interview guides were focused on the following themes: long-term sustainability of water points, maintenance and operations, availability of spare parts and capacity building. The interviews were then transcribed and analyzed through thematic textual analysis. The interview guide was designed around questions pertaining to long-term sustainability of water points, and the management and maintenance of water points. We started by analyzing the practices of the different actors within the community managed O&M processes, through which roles and responsibilities were further abstracted. Adding to the interviews, we also analyzed the recently drafted National Rural Water Supply Operation and Maintenance Management Strategic Framework. Combining these two lines of empirical material we identified five different roles in the institutional co-production of O&M. These positions are essential to understanding the agency of specific actors in O&M processes. Furthermore, they helped us in analyzing the power relations among the roles identified in the data.

Table 1. List of Respondents

Code	Name of the Woreda	Type of organization	Respondent position	Interview date
District / Village				

EQUITY NON-DISCRIMINATION AND INCLUSION (ENDI)

Citizen Empowerment & Inclusion

Code	Name of the Woreda	Type of organization	Respondent position	Interview date
[1]	Bahir Dar Zuria	WWO	Head of WWO	23.4.2013
[2]		WASHCO 1	Cashier	23.4.2013
[3]		WASHCO 2	Storekeeper	23.4.2013
[4]		WASHCO 3	Cashier	23.4.2013
[5]	Bure	WWO	Head of WWO, WaSH Coordinator	25.4.2013
[6]		WASHCO 1	Chairman	26.4.2013
[7]		WASHCO 2	Chairman	26.4.2013
[8]		WASHCO 3	Caretaker	10.5.2013
[9]		WASHCO 4	Secretary, WASHCO member	10.5.2013
[10]		Supplier	Shop owner	26.4.2013
[11]	Dembecha	WWO	Head of WWO	2.5.2013
[12]		WASHCO 1	2 WASHCO members	9.5.2013
[13]		WASHCO 2	2 WASHCO members and cashier	9.5.2013
[14]	Derra	WWO	Head of WWO	14.5.2013
[15]	Farta	WWO	Water Supply Process Owner	13.5.2013
[16]		NGO	CARE North Gondar Zone Program Office, Construction Supervisor	13.5.2013
[17]		WASHCO 1	Chairman's wife, caretaker & storekeeper, WASHCO member, user	13.5.2013
[18]		WASHCO 2	Chairman	13.5.2013
[19]	Fenote Selam	WWO	Head of WWO	10.5.2013
[20]		Supplier	Shop owner	10.5.2013
[21]	Fogera	WWO	CMP Supervisor	14.5.2013
[22]		WASHCO 1	Cashier	14.5.2013
[23]		Supplier	Shop owner	14.5.2013
[24]		Artisan association	3 members of the artisan association	14.5.2013
[25]	Guangua	WWO	Head of WWO	24.4.2013
[26]		WASHCO 1	Storekeeper	25.4.2013
[27]		WASHCO 2	Secretary, 2 storekeepers, guard	25.4.2013
[28]		Supplier 1	Shop owner	24.4.2013
[29]		Supplier 2	Shop owner	24.4.2013
[30]		Supplier 3	Employee of the shop	24.4.2013
[31]	Mecha	WWO	Head of WWO	2.5.2013
[32]		WASHCO 1	Chairman, guard, 11 users	11.5.2013
[33]		WASHCO 2	Chairman, husband of a WASHCO member	11.5.2013
[34]	Yilmana Densa	WWO	Head of WWO	29.4.2013
[35]		WASHCO 1	Guard, 8 users	29.4.2013
[36]		WASHCO 2	Secretary, user/community elder	29.4.2013
[37]		WASHCO 3	Storekeeper, previous cashier, current cashier	29.4.2013
[38]		WASHCO 4	Chairman, secretary	29.4.2013
[39]		WASHCO 5	Document keeper	30.4.2013
[40]		WASHCO 6	Chairman	30.4.2013
[41]		WASHCO 7	Cashier	30.4.2013
[42]		Amhara Credit & Savings Institution ACSI	Branch manager	30.4.2013
[43]		NGO 1	KfW/GIZ Focal person	30.4.2013
[44]		NGO 2	World Vision woreda office, Development facilitator	30.4.2013
[45]		Supplier	Shop owner	29.4.2013
<b>Regional</b>				
[46]	Bahir Dar	Water Bureau	Amhara National Regional State Water Resources Development Bureau, CMP Coordinator & Water Supply Process Owner	16.5.2013
[47]		Supplier / importer 1	Owner	11.5.2013
[48]		Supplier / importer 2	Regional office manager	16.5.2013
[49]		NGO 1	Organization for Rehabilitation and Development in Amhara / Executive Director	15.5.2013
[50]		NGO 2	Glimmer of Hope / Organization for Rehabilitation and Development in Amhara, WaSH Project Advisor	15.5.2013
<b>Federal</b>				
[51]	Addis Ababa	Ministry 1	Ministry of Water and Energy, Director of Water	9.8.2013

## EQUITY NON-DISCRIMINATION AND INCLUSION (ENDI)

### Citizen Empowerment & Inclusion

Code	Name of the Woreda	Type of organization	Respondent position	Interview date
			Supply and Sanitation Directorate	
[52]		Ministry 2	Ministry of Water and Energy, Procurement Specialist & Team Leader on One WASH National Program Procurement	9.8.2013
[53]		Supplier / importer	Marketing manager	13.8.2013

### Main results and lessons learnt

We present our findings on the level of organizational roles related to the discourse on community managed O&M. In our analysis we have distinguished between five different roles, each describing the different responsibilities and meanings attached to community managed O&M. These roles reflect how the different actors describe their role in relation to the discourse on community managed O&M.

The first role of “enablers” encompasses higher governmental bodies, donors and NGOs that provide the financing for the infrastructure and trainings, and thus set a framework and an overall discourse for governing community managed O&M. The new O&M Strategic Framework, for instance, is a joint effort of multi-stakeholder meetings, drafted under the bi-lateral COWASH project. Several NGOs have their own implementation guidelines which have slightly different approaches to community-managed O&M. They are responsible for formulating the policies and processes, deciding on the most suitable approach to provide access to drinking water, and making sure the policies trickle down to the level of implementation. The global discourses on rural water supply management naturally influence the enablers as financing is drawn from multiple international sources. Through joint stakeholder fora and consultative processes, enablers decide upon the responsibilities and activities within institutional co-production, assigning roles for the different actors. Ultimately, these roles have to be accepted by the government.

*"But of course, in order to make them able to do the O&M, the most important thing we have to do is to have a capacity building for the communities. The communities should be able, should be in a position to conduct O&M. And the need to have local service providers, so that they can hire people and professionals, and they can maintain and repair things, you know. So, these are, the O&M is totally the burden of the community. But we have to capacitate them to do the operation and maintenance." – Director of Water Supply and Sanitation Directorate, Ministry of Water and Energy of Ethiopia*

Interestingly, this view somewhat contradicts with recent literature on community managed O&M which emphasizes the external support required by the community.

The second role, the “supporters”, includes the governmental district officials and NGO field staff members that are responsible for a variety of activities: the monitoring of the implementation of water schemes, training of WASHCOs, conducting awareness raising activities in the communities, monitoring the usage and quality of water, and conducting major maintenance of water schemes. Their work is much about governing, e.g. setting the structures for community management, and mobilizing the communities, but also about strengthening and empowering the rural dwellers for their stated responsibilities. Politically (or ‘ideally’ in fact, since the accountability structures remain outside the scope of this paper.) they remain accountable to citizens, and they have access to skills and resources that are required for the functioning of water schemes.

*"We give two types of trainings. The first training is given at the construction phase. This training is for WASHCOs and it capacitates them on how to mobilize the community to assist in the construction process. The second training is a care taker training provided for two persons from each scheme. Therefore, in general, we give training to a total of seven persons per scheme, management training for five persons and technical training for two persons." – District Water Office Head, Mecha district*

In the context of Ethiopia, NGOs serve a similar role as demonstrated by the quote above and thus serve the role of “supporters” as indicated above.

## EQUITY NON-DISCRIMINATION AND INCLUSION (ENDI)

### Citizen Empowerment & Inclusion

Thirdly we have the private providers that benefit from the decentralization of responsibilities. Institutional co-production, according to the discourse, creates more space for private actors, as procurement is not undertaken in a centralized manner. Their role is to sell and provide for the members of the community, with the support of an enabling environment provided by the *enablers* and *supporters*. They remain under the control of *supporters* who are able to influence the buying behavior of WASHCOs, and who sometimes develop their own mechanisms for selling spare parts.

The fourth role, “empowered leaders” deals with WASHCO members that hold the role of change agents for the organizing of community contribution. Their role is to convince the rest of the community about the necessity of clean water, and the usefulness of regular tariff collection. Currently, the “empowered leaders” are responsible for deciding upon the tariffs and they receive support from the “supporters” in setting up the ideal tariffs. However, they do not hold the responsibility for ensuring the inclusiveness of tariffs, i.e. making sure that disadvantaged groups (e.g. widows, women-headed households, people with disabilities) are taken into consideration. This absence of social tariffs is supported by Wilbur et al. (2016) who documented the lack of inclusiveness and transparency in the current practices of tariff governance. The new Strategic Framework for O&M, however, is addressing tariff collection in a detailed manner, emphasizing the support required from local government, provision of subsidies for disadvantaged communities, and inclusion of life-cycle cost.

For these responsibilities they receive training on how to technically manage the water scheme as well as to raise awareness among community members. In performing their role, the “empowered leaders” implement the visions of *enablers* and *supporters*:

*“Previously, when this water point was constructed, we did not really think about taking care of the scheme. We only enjoyed the free water we got from the scheme. But now we have understood the problem of not having clean and potable water. So, in the future we will even make the required financial contributions if a new scheme is provided for us.” – WASHCO member, Guangua district*

Lastly, “uncompliant citizens” are the objectified community members that contribute to the institutional co-production of community managed O&M water schemes through tariffs. They are constructed as people that need to become aware of the benefits of clean drinking water, as otherwise they would not be willing to contribute money. In the current discourses, their space in community managed O&M is limited to financial contribution. They do hold the WASHCO accountable for managing the maintenance and overall service, but simultaneously they are constructed as problematic, “uncompliant citizens” who do not pay enough for the O&M.

*“It is very hard to get money from this community. You don’t know how much we suffered last time to collect the 500 birr from the community. This 500 birr was 10 birr per household. But nobody was willing to pay the 10 birr.” – WASHCO member, Mecha district*

Table 2. An Overview of the Roles Identified in the Community Managed O&M

	<b>Enablers</b>	<b>Supporters</b>	<b>Private providers</b>	<b>Empowered leaders</b>	<b>Uncompliant citizens</b>
<b>Actors</b>	Higher governmental bodies, donors, NGOs	District officials	Local suppliers of spare parts, artisans	WASHCO members	Community members who use the water scheme
<b>Relation to community managed O&amp;M</b>	Financing the rehabilitation of water schemes, providing access to water	Training, monitoring, undertaking major maintenance	Selling of spare parts for WASHCO members	Tariff collection, minor maintenance, setting up rules for the	Community contribution i.e. tariff payment

## EQUITY NON-DISCRIMINATION AND INCLUSION (ENDI)

### Citizen Empowerment & Inclusion

	Enablers	Supporters	Private providers	Empowered leaders	Uncompliant citizens
				usage of water schemes	

The discourse on community managed O&M influences power relations among the different roles. As creators of the policy, *enablers* are in the position to assign responsibilities to all actors involved. However, in theory they are also responsible for a variety of issues, such as creating awareness among the political leaders in order to ensure the adequate budget allocation to the implementation of O&M, strengthening private sector support for the O&M, taking the leading role in bulk procurement of spare parts for pumps, and education of professionals for the major O&M activities. These responsibilities, however, remain outside of the upward accountability structures and leave the other actors depending on the enablers. *Supporters* do voice out several issues that call for improvement, but do not hold the power to change things.

*“Before the construction phase, there is a preparatory phase, from July to October, where the communities need to be capacitated. However, both the capacity building and investment budgets are usually released at the same time. And we are forced to give capacity building trainings after construction has started. This creates a time constraint for us with regard to delivering the capacity building trainings.” – District Water Office Head, Guangua district*

*Supporters* are also powerless in terms of assuring sufficient training for the WASHCOs, making the implementation of community managed O&M unattainable. In most cases the trainings are not seen as adequate.

*“In addition, the caretaker training should equip the WASHCOs with minimal skills which should be enough to conduct only minor maintenance. However, this is also insufficient. How come the WASHCOs conduct maintenances after a one to two days training.” – District Water Office Head / Dembecha*

### Conclusions and Recommendations

Through our analysis we came to identify five roles that characterize the institutional co-production of community managed O&M in rural Ethiopia and how responsibilities are shared among the actors. We tried to show how the optimistic calls for community management also reproduce power relations among the various actors. Clearly the creation of a policy, assigning responsibilities to different groups, and dominant narratives reflect power, and the roles that people can accommodate. We do not want to suggest that community managed O&M and empowerment are simply misplaced ideals. However, comprehension of the relationship between policy and implementation needs to be rooted in a more detailed understanding of the power relations than is often the case. This should entail examination not only of individual agency and roles of empowerment, but also of how this is constrained and influenced by broader discourses and potential roles assigned for the actors (Cornwall, 2000).

In our study, the ideals of participative democracy that are embedded in the positive portrayal of institutional co-production (Ostrom, 2000; Fung, 2004), were lacking in the interviews with WASHCO members. Participatory democracy was reduced into financial tariff collection which was problematic amongst most water schemes. Thus in order for co-production to achieve its participative democratic ideals, more focus should be directed towards the expanding the discursive roles that can be assigned to end users. Especially the role of the “uncompliant citizen” is very limiting and creates an unproductive power relationship with end users. Including more members of the community in participatory capacity building efforts could be one way of addressing this issue. Discourses, roles and power relations, however, are not stable and keep on changing. With the new O&M Strategic Framework in place, it would be an interesting avenue for research to investigate how the legalization of WASHCOs will affect the discourses around O&M processes.

## EQUITY NON-DISCRIMINATION AND INCLUSION (ENDI)

### Citizen Empowerment & Inclusion

#### Acknowledgements

We would like to acknowledge the Community-Led Accelerated WaSH (COWASH) in Ethiopia project for the support provided in data collection and facilitation in organizing interviews.

#### References

- Adner, R. and Levinthal, D. 2001. Demand Heterogeneity and Technology Evolution: Implications for Product and Process Innovation. *Management Science*, Vol. 47, No. 5, pp. 611-628
- Annala, L., Sarin, A., Green, J., 2016: Co-production of frugal innovation: Case of low cost reverse osmosis water filters in India. Accepted for publication, *Journal of Cleaner Production*, forthcoming.
- Alvesson, M. and Deetz, S. (2000), *Doing Critical Management Research*, Sage, London
- Alvesson, M. and Willmott, H. (2002) Identity Regulation as Organisational Control: Producing the Appropriate Individual. *Journal of Management Studies*, 39, 619-44.
- Asthana, A., 2003. Decentralisation and Supply Efficiency: The Case of Rural Water Supply in Central India. *The Journal of Development Studies*, Vol. 39, No. 4, pp. 148-159.
- Brandsen, T., Pestoff, V., Verschuere, B., 2013. Co-Production as a Maturing Concept, in: Pestoff, V., Brandsen, T., Verschuere, B. (Eds.), *New Public Governance, the Third Sector, and Co-Production*. Routledge
- Carabine, J. (2001). Unmarried motherhood 1830-1990: A genealogical analysis. In: M. Wetherell, S., Taylor and S.J. Yates (Eds.): *Discourse as Data. A guide for Analysis*. London: Sage, pp. 267-310.
- Carter, R. C., Tyrrel, S. F., Howsam, P., 1999. Impact and sustainability of community water supply and sanitation programmes in developing countries. *Journal of the Chartered Institution of Water and Environmental Management*, Vol. 13, pp 292-296
- Chowns, E., 2015. Water point sustainability and the unintended impacts of community management in Malawi. 38th WEDC International Conference, Loughborough University, UK, 2015.
- CMP, 2015. Community Managed Project website, accessible: <http://www.cmpethiopia.org/page/1124>
- Cornwall, A., 2000. Beneficiary, Consumer, Citizen: Perspectives on Participation for Poverty Reduction. *Sida Studies* no 2.
- Foucault, M. (2000) Introduction to 'The Use of Pleasure'. In du Gay, P., Evans, J. and Redman, P. (eds.), *Identity: a Reader*. Sage Publications, London, pp. 360-70.
- Fung, A. 2004. *Empowered Participation: Reinventing Urban Democracy*. Princeton, NJ: Princeton University Press.
- Hall, S. (1992) *The West and the Rest*. In Hall, S. and Gieben, B. (eds.), *Formations of Modernity*. Polity Press/The Open University, Cambridge, pp. 275-332.
- Hall, S. (2001) Foucault: Power, Knowledge and Discourse. In Wetherell, M., Taylor, S. and Yates, S.J. (eds.), *Discourse Theory and Practice*. Sage Publications, London, pp. 73-81.
- Harrison, T., Waite, K., 2015. Impact of co-production on consumer perception of empowerment. *Serv. Ind. J.* 35 (No. 10), 502-520.
- Harvey, P. and Reed, R., 2006. Community-managed water supplies in Africa: sustainable or dispensable? *Community Development Journal*, Vol. 42 No 3, pp. 365-378.
- Hilton, T., Hughes, T. 2013. Co-production and self-service: The application of Service-Dominant Logic. [\*Journal of Marketing Management\*](#). May 2013, Vol. 29 Issue 7-8, p861-881. 21p.
- Joshi, A., Moore, M., Institutionalised Co-production: Unorthodox Public Service Delivery in Challenging Environments. *The Journal of Development Studies*, Vol.40, No.4, April 2004, pp.31 - 49.
- Kobrin, S.J., 2009. Private Political Authority and Public Responsibility: Transnational Politics, Transnational Firms, and Human Rights. *Business Ethics Quarterly*, 19(3), 349-374.
- Koryang, T., 2011. Community Participation and Management of Sustainable Rural Water Supply: a comparative study of three communities in Uganda. A research paper presented at International Institute of Social Studies, The Hague. Available online.
- Ostrom, E., 2000. Collective action and the evolution of social norms. *Journal of Economic Perspectives* 14 (3), pp.137-158
- Ostrom and Baugh, 1973. *Community Organization and the Provision of Police Services*. Sage Publications.
- O'Malley, P., 2008. Experiments in risk and criminal justice. *Theor. Criminol.* 12 (4), 451-469.

## EQUITY NON-DISCRIMINATION AND INCLUSION (ENDI)

### Citizen Empowerment & Inclusion

- Parks, R., Baker, P., Kiser, L., Oakerson, R., Ostrom, E., Ostrom, V., Percy, S., Vandivort, M., Whitaker, G., Wilson, R., 1981 1999; “Consumers as Co-Producers of Public Services: Some Economic and Institutional Considerations”, *Policy Studies Journal*.
- Pestoff, Victor, 1998. *Beyond the Market and State: Social Enterprises and Civil Democracy in a Welfare Society*; Aldershot, UK; Brookfield, USA & Singapore: Ashgate.
- Pestoff, V., 2013. *Citizens and Co-Production of Welfare Services: Childcare in Eight European Countries*. Pestoff, V., Brandsen, T., Verschuere, B. (Eds.), *New Public Governance, the Third Sector, and Co-Production*. Routledge.
- Reed, A., M., and Reed, D. (2009). *Partnerships for Development: Four Models of Business Involvement*. *Journal of Business Ethics* (2009) 90:3–37
- Schouten, T, 2006. *Scaling Up Community Management of Rural Water Supply*. WELL resources, Water, Engineering and Development Centre (WEDC), Loughborough University, UK. [online] Available at: <http://www.lboro.ac.uk/well/resources/fact-sheets/fact-sheets-htm/Scaling%20up.htm>
- Vancoppenolle, D., Verschuere, B., 2013. *The Challenges of Co-Management for Public Accountability: Lessons From Flemish Childcare*, in: Pestoff, V., Brandsen, T., Verschuere, B. (Eds.), *New Public Governance, the Third Sector, and Co-Production*. Routledge
- Voorberg, W.H., Bekkers, V.J.J.M., Tummers, L.G., 2014. *A Systematic Review of Co-Creation and Co-Production: Embarking on the social innovation journey*. *Public Manag. Rev.* 1–25.
- Wehn, U. and Evers, J., 2015. *The social innovation potential of ICT-enabled citizen observatories to increase eParticipation in local flood risk management*. *Technology in Society*, August, pp.187-198
- Wilbur J., Norman R., Huggett C., 2016. *Reducing Inequalities in Water, Sanitation and Hygiene (WASH) - A synthesis of experiences and lessons discussed in the RWSN Equality, Non-discrimination and Inclusion (ENDI) Group 2015*. Available at: <http://www.rural-water-supply.net/en/resources/details/771> }

## SUSTAINABLE GROUNDWATER DEVELOPMENT

### Professionalising Drilling & Manual Drilling

## 3.2 SUSTAINABLE GROUNDWATER DEVELOPMENT

### 3.2.1 Professionalising Drilling & Manual Drilling

---

## Registration of groundwater consultants in Uganda: rationale and status

---

Type: Short Paper (up to 2,000 words)

**Author:** *Dr Callist Tindimugaya, Commissioner for Water Resources Planning and Regulation, Directorate of Water Resources Management (Ministry of Water and Environment), Uganda Email: [callist.tindimugaya@mwe.go.ug](mailto:callist.tindimugaya@mwe.go.ug); Tel: 256 77 2 521413*

### Abstract/Summary

There is heavy reliance on groundwater in most of Uganda for rural and urban water supply due to its wide distribution and general good quality. While groundwater development is on the increase water supply coverage has not increased substantially despite increased funding. This is attributed to a number of reasons including poor performance of groundwater consultants. Groundwater consultants play a big role in the success of borehole drilling in terms of selection of drilling sites, supervision of drilling activities and general guidance of drilling operations. There is therefore need to improve the professional conduct of groundwater consultants. It's planned to register individual groundwater professionals and groundwater companies. Evaluation of applications for registration is ongoing and the list of registered groundwater consultants will be issued out in June 2016 and will be updated and issued out annually. Improved regulation of the drilling industry will ensure efficiency and effectiveness in groundwater development.

### Introduction

There is heavy reliance on groundwater in most of Uganda for rural and urban domestic water supply due to its wide distribution and general good quality. Groundwater development started in the 1930s, for domestic rural water supply through deep boreholes and springs. Since early 1990s there has been a rapid increase in groundwater development for both rural and urban water supply due to the need to have water supply systems that can easily be operated and managed by the users. There are approximately 40,000 deep boreholes, 30,000 protected springs and 16,000 shallow wells in Uganda. Currently over 250 small towns and rural growth centres have operational groundwater based water supply systems from deep boreholes and over 30 more systems are under construction. There is also an estimated 860 sub-county (local government) headquarters in the country which are targeted for piped water supply and almost all of them will be based on groundwater. Private companies and individuals are focusing also on groundwater development especially in urban areas (over 400 private motorized boreholes/wells in Kampala alone). Boreholes and shallow wells with yields <1 m<sup>3</sup>/hour are installed with hand pumps for rural water supply while boreholes with yields >3 m<sup>3</sup>/hour are normally installed with motorized pumps for piped water supply. An average of 1200 deep boreholes and 900 shallow wells are constructed annually in Uganda. In order to achieve 100% access to safe drinking water by 2040 it is estimated that an additional 40,000 boreholes for rural water supply and over 350 production boreholes for piped water supply in small towns and rural growth centres will need to be constructed.



## SUSTAINABLE GROUNDWATER DEVELOPMENT

### Professionalising Drilling & Manual Drilling

#### Groundwater development concerns

While groundwater development is on the increase in Uganda there has been concern that water supply coverage has not increased substantially despite increased funding to the water sector. The following are some of the reasons advanced for this concern:

- Water sources are being constructed in areas with very low groundwater potential resulting in low drilling success rates and also water sources are yielding inadequate quantities of water
- Water sources are being constructed in areas with poor water quality leading to either abandonment or limited use
- Resources are being spent on very expensive water supply options when cheaper options are available
- Quality of boreholes is poor leading to high failure rates after construction. It is reported that boreholes drilled over the last 10 years are failing faster than those drilled before.
- The capacity of key players in the drilling industry from the central government, local governments, Non- Governmental Organisations, private sector etc is limited
- Some boreholes are drilled close to each other and to existing boreholes despite the recommended distance between hand pumps and between motorized boreholes being 500m and 1000m respectively
- Some boreholes are drilled too deep even when there is no water and this has implications on the costs of boreholes. It is reported that the cost of boreholes is much higher now and way beyond the estimated costs based on standard unit costs. Costs of some production boreholes have reportedly doubled over the last 10 years.
- Performance of many groundwater consultants is reported to be poor and this is reflected in the poor quality of borehole siting reports and low drilling success rates. Information available indicates that some contracts for groundwater investigations are awarded to unqualified individuals/companies
- Many private groundwater developers have no technical knowledge and so depend on the good will of groundwater consultants who tend to do poor quality work for unsuspecting clients.
- There is reduced focus on use of standards in the drilling industry such as standard Terms of References, specifications, well designs, bidding documents, evaluation criteria, drilling and supervision guidelines etc). For example the nature of contracts some groundwater developers issue out are found not to promote cost effectiveness in borehole drilling. These include the no cure no pay contracts, lump sum contracts, lumped drilling and supervision contracts etc

#### Ongoing/planned activities to improve the drilling industry

In order to improve the general performance of the drilling industry a number of activities are either being implemented or planned to be implemented very soon. These include among others (i) strengthening regulation and supervision of the industry, (ii) developing a licensing systems for groundwater consultants/hydrogeologists, (iii) developing a performance monitoring system for drillers and groundwater consultants, (iv) using groundwater mapping outputs to develop/update drilling guidance documents (Bills of Quantities, cost estimates etc), (v) continued and integrated capacity building of key players in the drilling industry (central government, local government, NGOs, private sector etc), and (vi) establishment of a Water Institute to handle continued capacity building, applied research and documentation in the water sector in Uganda. Licensing or registration of groundwater consultants/hydrogeologists is one of the activities that have been given priority by Uganda government over the next few years.

## SUSTAINABLE GROUNDWATER DEVELOPMENT

### Professionalising Drilling & Manual Drilling

#### Justification and status of licensing or registration of groundwater consultants

A number of concerns regarding the borehole drilling industry are attributed to the poor performance of groundwater consultants. Groundwater consultants (individuals and companies) play a big role in the success of borehole drilling in terms of selection of borehole drilling sites, supervision of drilling activities and general guidance of drilling operations. There is therefore a need to improve the professional conduct of groundwater consultants if the borehole drilling industry is to produce the required quality of work. Registration or licensing of groundwater consultants will be done to supplement similar efforts already done for borehole drilling contractors which have greatly contributed to improvements in borehole drilling.

Registration will be done for individual groundwater professionals/hydrogeologists and groundwater companies. An advert was run in late 2015 requesting groundwater consultants (individuals and companies) to apply for registration with Ministry of Water and Environment and evaluation of applications is ongoing. A list of registered groundwater consultants (individuals and companies) will be issued out in June 2016. A list of registered groundwater consultants (individuals and companies) will be updated and issued out annually as new applicants come on board. Groundwater consultants (individuals and companies) will have to comply with certain conditions as will be spelt out in their registration certificates. Compliance to these conditions will determine annual renewal of registration. One of the key condition to be considered is professional performance.

The evaluation criteria developed for evaluation of applications for registration as either an individual groundwater consultant or a groundwater consulting company are as follows:

#### a) Evaluation criteria for individual groundwater consultants

Individual groundwater consultants/hydrogeologists will be grouped into categories namely: Junior hydrogeologists/consultants, hydrogeologists/consultants and Senior or Expert Hydrogeologists/consultants. Evaluation criteria involves: Education (to assess the knowledge of applicants), Experience (to assess the skills) and examination-exercises that will be undertaken to assess the technical competence of the consultants. A group to which a hydrogeologist/consultant will be registered will depend on the combination of the above 3 criteria items.

#### b) Evaluation criteria for groundwater consulting companies

Criteria used to evaluate applications for registration as a groundwater consulting company include: Company registration and ownership, staffing (number and qualifications), equipment (ownership or leased), experience (number and nature of projects handled), references from previous clients etc. Whether a company is registered or not depends on fulfilling the above criteria items.

### Conclusions and Recommendations

There are challenges facing the drilling industry in Uganda that need to be addressed if the quality of boreholes has to be improved. Regulation and supervision of the industry needs to be strengthened. Regulating the drilling industry benefits the water users as well as the drilling permit holders and consultants, and should therefore be embraced by all. Improved regulation of the drilling industry (drillers and consultants) will ensure efficiency and effectiveness in groundwater development. Continued and integrated capacity building of key players in the drilling industry (central government, local government, NGOs, private sector etc) is strongly needed. All key players in the drilling industry are requested to cooperate and support these initiatives.

### Acknowledgement

## SUSTAINABLE GROUNDWATER DEVELOPMENT

### Professionalising Drilling & Manual Drilling

*The support provided by the Governments of Denmark, Austria and Uganda for activities on regulation of the drilling industry in Uganda is highly acknowledged.*

#### References

DWRM (2014). Mapping of Groundwater Resources in Uganda. Final Project report to the Government of Uganda and European Union

## SUSTAINABLE GROUNDWATER DEVELOPMENT

### Pump Technologies – Solar and Hand-powered

#### 3.2.2 Pump Technologies – Solar and Hand-powered

---

# It is time for the problem of pump corrosion and consequent failure to be eliminated

---

Type: Long Paper

Authors: Jacinta Nekesa<sup>1</sup>, Lawrence Brown<sup>2</sup>, Vincent Casey<sup>3</sup>, Jacob D. Carpenter<sup>4</sup>

<sup>1</sup>Head of Programmes, WaterAid Uganda +256 41 4505795, [jacintanekesa@wateraid.org](mailto:jacintanekesa@wateraid.org); <sup>2</sup>Senior Hydrogeologist, Hafren Water Barkers Chambers, Barker Street, Shrewsbury, SY1 1SB (UK) [lawrence.brown@hafrenwater.com](mailto:lawrence.brown@hafrenwater.com); <sup>3</sup>Senior WASH Advisor, Programme Support Unit, WaterAid, 47-49 Durham Street, London, SE11 5JD (UK), +44 207 7934932, [VincentCasey@wateraid.org](mailto:VincentCasey@wateraid.org); <sup>4</sup>Independent WASH Consultant, 1891 Flat Shoals Road, Atlanta, GA 30316 (USA), [jcarpenter@mail.usf.edu](mailto:jcarpenter@mail.usf.edu)

### Abstract/Summary

Handpump corrosion has been known about for over 30 years following a number of significant research projects undertaken in the late 1980s. Nevertheless, aid organisations and governments have continued to install pumps manufactured with unsuitable materials, leading to high maintenance costs, pump failure and rejection of water sources due to poor water quality. The WASH sector has so far failed to address this recurrent problem which threatens to hamper progress towards achievement of SDG 6. WaterAid has undertaken field research in northeastern Uganda to highlight the issue again and to provide data to support changing procedures. The results of the research have been presented to stakeholders in local government and a number of actions implemented by WaterAid's partners in Uganda.

### Introduction

The problem of high concentrations of iron in rural water supplies is well known across many countries in Africa and elsewhere. Although elevated concentrations of iron are not considered a particular health problem, aesthetic issues may result in a reluctance to use a water point and in severe cases, abandonment of the water point for an alternative, and potentially unsafe, source. Typical problems include metallic taste, discoloured and turbid water, discolouration of water following pumping and discolouration of food and clothing. The World Health Organisation has given an advisory limit of 0.3 mg/l for drinking water supply (WHO, 2011), which is considered the limit at which taste become apparent. However, less stringent limits are often used in national standards for untreated rural water supplies, for example, in Uganda a value of 1 mg/l is specified (UNBS, 2008).

Iron is present in soils and rock formations in two forms: reduced soluble ferrous iron ( $Fe^{+2}$ ), or oxidised insoluble ferric ion ( $Fe^{+3}$ ). The highly soluble nature of the ferrous iron can mean that, if conditions are right, groundwater can hold significant concentrations of iron yet appear clear and colourless because the iron is in solution. When such groundwater is pumped out and exposed to the atmosphere, oxygen will convert the ferrous iron to ferric iron, which reacts with other components in the water to form insoluble iron hydroxides. These precipitate out to cause red/brown cloudiness in the water and staining. This oxidation process can take some time, so apparently clear water can be produced at the pump, but then discolours later, once the water has been standing.

Two sources of high iron concentrations are possible in pumped groundwater: a natural (geogenic) source in the aquifer, or as the result of the corrosion of susceptible pump components. In some circumstances a combination of both is possible. It is important to distinguish which of these is the source in any particular case as this will point to potential solution(s). For example, where a natural origin is identified,

## SUSTAINABLE GROUNDWATER DEVELOPMENT

### Pump Technologies – Solar and Hand-powered

implementers may install iron removal plants on handpumps. In other circumstances, it may be the handpump itself which is causing, or significantly adding to, the problem. This has been observed particularly the case where India Mark II handpumps are deployed, but other models of handpump may also be affected.

The corrosion of susceptible pump components can be significantly enhanced by the action of iron bacteria. Although not a health hazard in themselves, they can have a significant detrimental impact on water quality, as well as resulting in clogging of pumps and borehole screens.

Perhaps the most surprising aspect of handpump corrosion in rural water supply is that it has been thoroughly documented and specific preventative guidelines have been available for 30 years. There appears to be a general awareness of the problem, although this has not been translated into action. A survey of online discussions (Furey, 2014) on handpump technologies among rural water supply specialists and practitioners between 2012 and 2014 concluded that water quality, particularly related to high iron, aggressive groundwater, and corrosion, was the main issue. Particular needs identified from the discussions were:

- better testing and monitoring of groundwater quality so that galvanised steel (GI) pump components are not installed;
- a clearer understanding of whether high iron levels are caused by natural conditions or by pump corrosion, and,
- the replacement of GI pipes and pump rods in all existing pumps in aggressive groundwater.

Despite this knowledge, it is apparent that the corrosion of handpump components continues to be a significant problem in some places, where it impairs water quality, handpump performance, and functional sustainability. In these places, communities are burdened with a handpump that is costly to maintain and produces water that is undesirable.

This paper sets out to briefly describe some of the background to the issues, research work that WaterAid has been undertaking in Uganda to highlight the issue, feed back from this work and recommendations to improve the situation and prevent continuation of this problem which is helping to prevent the provision of rural water supplies becoming truly sustainable.

### Description of the Case Study – Approach or technology

#### Background

Identification of the problem and still the most significant research into the issue, dates back to the 1980s and a World Bank / UNDP Project: ‘Laboratory and Field Testing and Technological Development of Community Water Supply Handpumps’, UNDP-INT/81/026 (the ‘Handpumps Project’). The final project report (Arlosoroff et al, 1987) included a significant emphasis on the corrosive effects of aggressive groundwater, which it characterised as ‘much more widespread and much more damaging than previously suspected in both Africa and Asia’. The report highlighted the importance of corrosion-resistant materials and concluded that, while assessment of corrosivity of groundwater is a complex matter, pH is a ‘valuable indicator of aggressivity’; pH below 6 is likely to be “highly aggressive” while pH above 7 is unlikely to contribute to corrosion.

In a subsequent report, Langenegger (1987) recognised the complexity of corrosion, its dependence on a number of parameters and the lack of a universal index for predicting corrosion in all water quality conditions. Based on data collected during the Handpumps Project, Langenegger considered that pH,

## SUSTAINABLE GROUNDWATER DEVELOPMENT

### Pump Technologies – Solar and Hand-powered

which is easily measured in the field, was a useful corrosion indicator and he developed a set of guidelines for the use of galvanised steel riser pipes and pump rods, reproduced as Table 1.

Table 1. pH-based index for applicability of galvanised downhole components

pH	Application of galvanised material	Aggressivity of water
pH > 7	Suitable	Negligible
6.5 < pH ≤ 7	Limited	Little to medium
6 < pH ≤ 6.5	Not recommended	Medium to heavy
pH ≤ 6	Not recommended	heavy

Source: Langenegger, 1987

In 1994 the World Bank published one of the most extensive and complete research-based resources on handpump corrosion. The report (Langenegger, 1994) was based on field and laboratory experience in the Handpumps Project gained in West Africa (Burkina Faso, Ivory Coast, Ghana, Mali and Niger). It provides details of the characteristics of corrosion and the various geological, chemical, electrochemical, and biological factors associated with it. Some key conclusions included:

- natural iron concentrations in groundwater in the region was rarely greater than 1 mg/L,
- High iron concentrations in handpump wells was usually caused by handpump corrosion. To confirm this, Langenegger (1994) suggested performing a pumping test with periodic sampling to measure iron concentration. If the major source of iron is corrosion, then the iron concentrations will drop rapidly after pumping continuously for a few minutes,
- galvanization does not protect riser pipes and pump rods from corrosion where pH < 6.5 and provides limited protection for pH of 6.5 – 7,
- lower handpump usage results in more serious high-iron problems,
- the internal surface of immersed pipes are less corroded than the external surfaces, while the external surface of pipes above the water level have negligible corrosion,
- stainless steel pump rods had corrosion rates an order of magnitude less than galvanized pump rods.
- A simple pH index (Table 1) was sufficient to determine the potential for electrochemical corrosion, which is the type of corrosion that is primarily responsible for the elevated iron levels found in many wells

Another important issue is the role of bacteria in the geochemical cycle of iron in respect of pump corrosion and production of poor quality water from handpumps. Iron bacteria are a well-known cause of problems in water supplies around the world, both in abstraction boreholes and water distribution systems. These bacteria can grow in either aerobic (oxygen present), or anaerobic (oxygen absent) conditions. In aerobic conditions, the specialised bacteria that influence the geochemical cycle of iron are termed iron bacteria, or iron-related bacteria (IRB). Anaerobic corrosion is commonly the result of the presence of sulphate-reducing bacteria (SRB). Both these types of bacteria are reported to be present naturally in most aquifers (Houben and Treskatis, 2007, P 68).

Iron bacteria use the oxidation of ferrous iron to insoluble ferric hydroxides as an energy source. The ferrous iron can originate either naturally in the aquifer, or as a consequence of the electrochemical corrosion of pump components. According to Cullimore and McCann (1978), iron bacteria have been

## SUSTAINABLE GROUNDWATER DEVELOPMENT

### Pump Technologies – Solar and Hand-powered

found in waters with iron concentrations as low as 0.02 mg/l, but generally require higher concentrations to thrive. In flowing water, such as an abstraction borehole, they reported that growth of iron bacteria may be expected if iron concentrations exceed 0.2 to 0.5 mg/l. The rate of bacterial growth is controlled by a number of factors including temperature, groundwater flow rate and pH.

The activity of IRB results in the deposition of thick ferric hydroxide ochre and the development of a characteristic orange slime coating that is often noted in affected wells (Fader, 2011). The mobilisation of these products when pumping, results in the rejection of the water by users.

Sulphate-reducing bacteria are considered to be the most common cause of microbially induced corrosion (MIC). As part of their life-cycle the bacteria produce hydrogen sulphide which reacts with ferrous iron to produce sulphuric acid which causes further corrosion. One of the solid products is a characteristic black deposit comprised of iron oxides and sulphides, which can be recognised by a ‘rotten eggs’ (hydrogen sulphide) smell if a few drops of dilute acid are placed on a sample. The bacteria can sometimes be found beneath oxygen tolerant bacteria where oxygen is absent. SRB-induced corrosion rates can be very high and Houben and Treskatis (2007, P 58) quote rates of several millimetres per year. Fader (2011) noted the typical products of SRB bacteria in boreholes in Uganda which had black slime of the riser pipes and a smell of rotten eggs. Evidence of significant corrosion through the wall of riser pipes was also apparent.

### WaterAid Uganda's experience

WaterAid Uganda (WAU) currently operates in a number of districts in North East Uganda working closely with the District Local Governments and through two local implementing partners, Church of Uganda-Teso Dioceses Planning and Development Office (CoU-TEDDO) and Wera Development Agency (WEDA). In two of these districts, Amuria and Katakwi, there had been increasing concerns over problems with poor water quality in groundwater sources due to high iron concentrations.

Increasing concerns with the quality of water sampling being undertaken by drilling contractors led in 2012 to WAU deciding to use staff from the Government Laboratory in Mbale to carry out on-site pH measurements at boreholes before handpump installation rather than including testing in the drilling contract. Subsequent analysis of these pH measurements in Amuria and Katakwi districts indicated that the pH of the groundwater was much lower than was previously suspected. Out of 34 samples, 91% were below pH 6.5 and 38% below pH 6. This reinforced the suspicion that corrosion was likely to be contributing to the high iron concentrations reported in groundwater sources.

### Diagnosis of the origin of high iron in rural water supplies

In August 2014 WaterAid Uganda undertook a field testing programme on a number of recently installed boreholes where high iron concentrations had been reported by communities; in one case this had resulted in the abandonment of a newly constructed supply. The objective of the programme was to evaluate the origin of observed high iron concentrations using the procedure described by Langeneggar (1987 and 1994) and to test the use of a portable iron testing kit manufactured by Palintest.

The pumping test proposed by Langeneggar simply involves flushing out a well that has been left unused for a short period of time and observing the change in iron concentration. The corrosion of pump materials will release soluble iron into the well water at a rate that will generally be greater at low pH. While a well is in use, iron released by the corrosion process will be diluted by groundwater entering the well. However, when a pump is out of use, for example overnight, concentrations will gradually increase and the concentration of iron will be much higher in the morning. The test simply involves pumping a well early in the morning, before it has been used, and measuring iron concentrations at intervals until at least a volume equivalent to the column of water held in the borehole is removed. At this time, the water held in the well is being replaced by fresh groundwater. When corrosion is the main source of iron, concentrations should drop rapidly until they stabilise at the natural background concentration in the aquifer (depending on how long pumping continues). If, on the other hand, iron concentrations remain high throughout continued pumping, it is likely that the iron originates from the aquifer.

## SUSTAINABLE GROUNDWATER DEVELOPMENT

### Pump Technologies – Solar and Hand-powered

Boreholes affected by high iron concentrations often produce very turbid water comprised of corrosion products precipitated in the borehole and sides of the riser pipe, as well as products of bacterial activity. Although this turbidity is generally reported at the start of pumping, increases in turbidity can occur at any time. In order to test samples representative of water quality in the well and in natural groundwater and to prevent unrepresentative ‘spikes’ in iron concentrations due to turbidity, the samples need to be filtered before testing.

The iron-testing kit selected for the research uses a simple colour comparison technique requiring the addition of a single reagent, in tablet form, to a sample to produce a colour change, the intensity of which is proportional to the concentration of iron. The colour of the test sample is then compared to a standard colour disc (Figure 3). For this study, the High Range (0 to 10 mg/l) test kit was used, the colour disc for which has 9 colour matches at 0.5, 1.0, 1.5, 2.0, 3.0, 4.0, 5.0, 7.5 and >10 mg/l.

Before testing, the boreholes were locked overnight so that test pumping would start after the boreholes had remained unused for a few hours. To enable a suitable period of pumping to be estimated and timing of sampling set, the volume of water held in the riser pipe and in the borehole need to be known. These volumes are significant because the highest iron concentrations would be expected in water held in the riser pipe, while after the removal of at least one well volume the iron concentrations should be close to the natural concentration in the aquifer. For the tests, these volumes were estimated from borehole completion reports, assuming no changes to the borehole had been made and water levels were similar to those at the time of construction. By assuming a pumping rate, the timing of sampling could be predicted. Actual pumping rates were then measured during the test.

Five boreholes with India MkII pumps and GI riser pipes installed were tested at locations indicated on Figure 1. A steady pumping rate was maintained and samples taken at intervals so that the first was representative of water held overnight in the riser pipe, and subsequent samples represented water held in the borehole at various times. Pumping was continued for sufficient time (approximately 2 hours for these boreholes) such that the final samples were taken after at least one well volume had been pumped. In all cases water was pumped using the installed handpump.



## SUSTAINABLE GROUNDWATER DEVELOPMENT

### Pump Technologies – Solar and Hand-powered

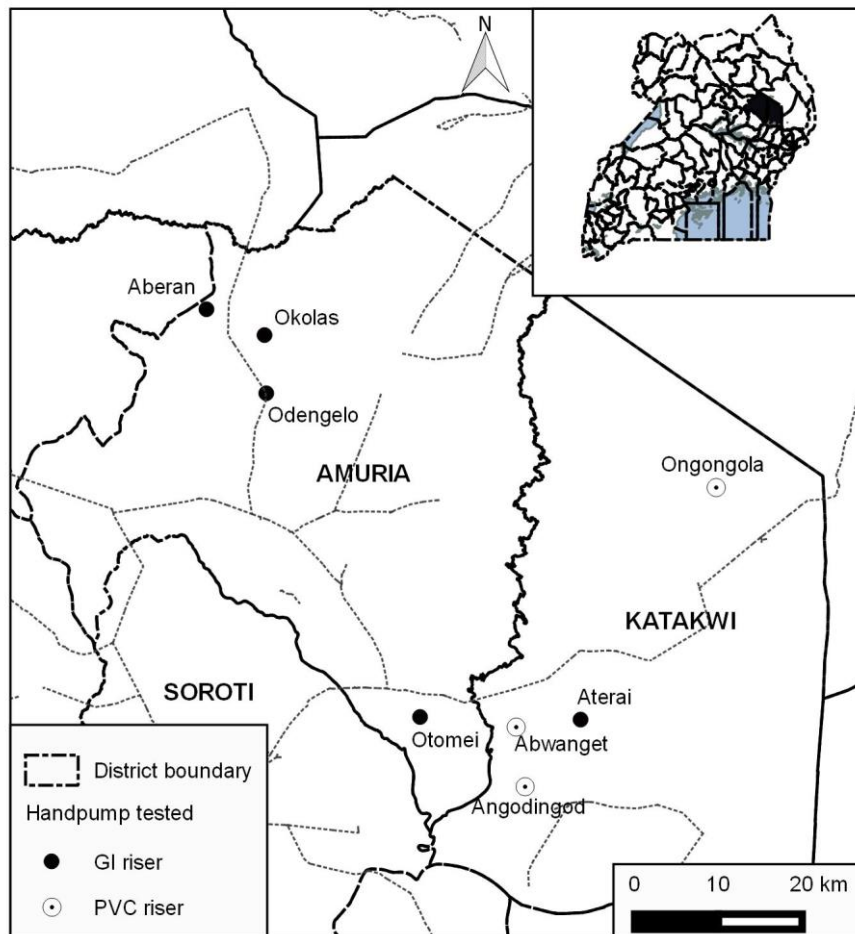

Figure 1. Location of boreholes sampled

In all the boreholes tested, the water discharged was clear and colourless from the start of pumping, although small solid particles, presumed to be corrosion products (rust), were often present. In several boreholes the discharge became turbid for a short period, before clearing again. It was also found that if the boreholes were pumped vigorously, the discharge became brown and turbid. It is supposed that only when this high pumping rate is applied, do biofilm and other corrosion products become detached from the inside of the riser pipe.

Samples were tested on-site for pH and electrical conductivity using calibrated probes. Due to potential interference from particulates originating from pump corrosion, samples tested for iron were filtered at 0.45  $\mu\text{m}$ . If these particles were included the tests results might not be representative of the true groundwater quality. This filtration has the potential to remove any iron that may have been precipitated out of solution in the time between sampling and testing, resulting in lower iron concentrations. However, in all cases filtration was undertaken immediately after sampling and it is considered that this will have minimised the impact of any rapid precipitation. To evaluate this, a number of duplicate unfiltered samples were also analysed on site.

Further duplicate filtered and unfiltered samples were also taken for subsequent analysis at the Ministry of Water and Environment's laboratory in Entebbe. All the samples were kept cool and delivered to the laboratory within 1 week of sampling. Although it was not possible to add any preservative to the samples to ensure iron remained in solution during transport, the samples were subsequently acidified in the laboratory prior to analysis, ensuring that any precipitated iron was re-dissolved.

## SUSTAINABLE GROUNDWATER DEVELOPMENT

### Pump Technologies – Solar and Hand-powered

Following the tests, the riser pipes on some of the handpumps were pulled to allow inspection for signs of corrosion. Evidence of corrosion was seen at all the sites, in particular at Odengelo village where the riser pipe was found to be leaking. The threads on some pipe joints at this handpump were severely damaged (Figure 2) and also indicated the use of sub-standard material. This borehole was only completed in October 2013 and the pump installed in December 2013, indicating how rapidly corrosion can affect a handpump under certain groundwater conditions.



*Figure 2 Threads on riser pipe at Odengelo, 1 year after installation*

### Main results and lessons learnt

The results from the field analysis using the Palintest kit show a clear colour change from deep red (sampled from riser pipe) to light orange at the end of the test, indicating a decline in iron concentration. An example from the test at the Odengelo borehole is shown on Figure 3 with the iron concentrations interpreted from the comparator disc indicated.

## SUSTAINABLE GROUNDWATER DEVELOPMENT

### Pump Technologies – Solar and Hand-powered

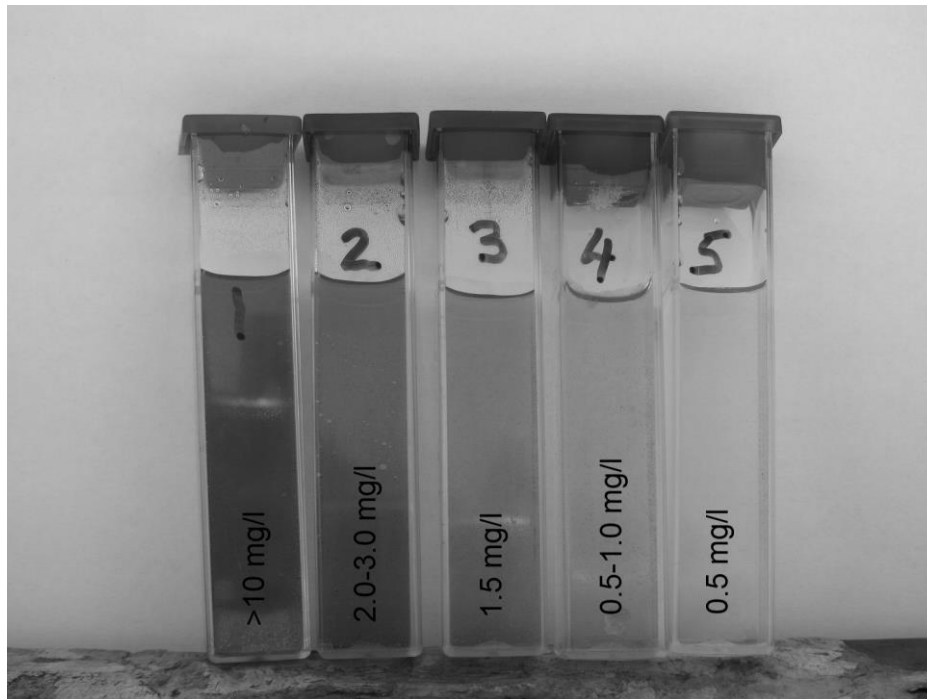

Figure 3. Results of Palintest analysis at Odengelo handpump with GI riser

Table 2 shows a comparison between the field test results from the Palintest kit and analysis at the laboratory for filtered samples. The field results tend to be higher, possibly indicating iron that will have precipitated out during transport was not recovered by acidification at the laboratory. Better results may have been obtained if it had been possible to preserve the samples with nitric acid in the field.

Table 2. Comparison of laboratory and field test results for boreholes with GI risers

	volume	(litres)	5	153	459	918	1,224
Odengelo	Fe Palintest	(mg/l)	>10	2.0-3.0	1.5	0.5-1.0	0.5
	Fe lab	(mg/l)	21	1.6	0.77	0.45	0.5
	volume	(litres)	6	360	720	1080	1440
Aberan	Fe Palintest	(mg/l)	>10	7.5	1.5	0.5-1.0	0.5-1.0
	Fe lab	(mg/l)	26	1.91	1.23	0.74	0.69
	volume	(litres)	6	360	720	1080	1440
Otomei	Fe Palintest	(mg/l)	5	1.5	1.0-1.5	1.0-1.5	0.5-1.0
	Fe lab	(mg/l)	1.17	0.49	0.67	0.63	0.48
	volume	(litres)	5	324	648	929	1296
Aterai	Fe Palintest	(mg/l)	>10	1.0-1.5	0.5-1.0	0.5-1.0	1
	Fe lab	(mg/l)	4.5	0.73	0.71	0.28	0.86
	volume	(litres)	6	360	720	1080	1440
Okolas	Fe Palintest	(mg/l)	>10	4	1	0.5-1.0	-
	Fe lab	(mg/l)	25	3.5	0.36	0.2	0.17

Note: All analysis on filtered samples

pH values in the samples recorded at the end of the test ranged from 6.38 to 6.97, indicating (from Table 1) that GI pipes would not be recommended in four of the boreholes and have limited suitability in the

## SUSTAINABLE GROUNDWATER DEVELOPMENT

### Pump Technologies – Solar and Hand-powered

fifth. In three of the boreholes the initial filtered iron concentrations, which varied from 21 to 26 mg/l, had reduced to between 0.5 and 0.17 mg/l by the end of the test. In the remaining two boreholes, the initial iron concentrations were lower at 4.5 and 1.17 mg/l and these had reduced to 0.86 and 0.48 mg/l respectively by the end of the test. The sharp decline in iron concentration in the samples is illustrated graphically on Figure 4.

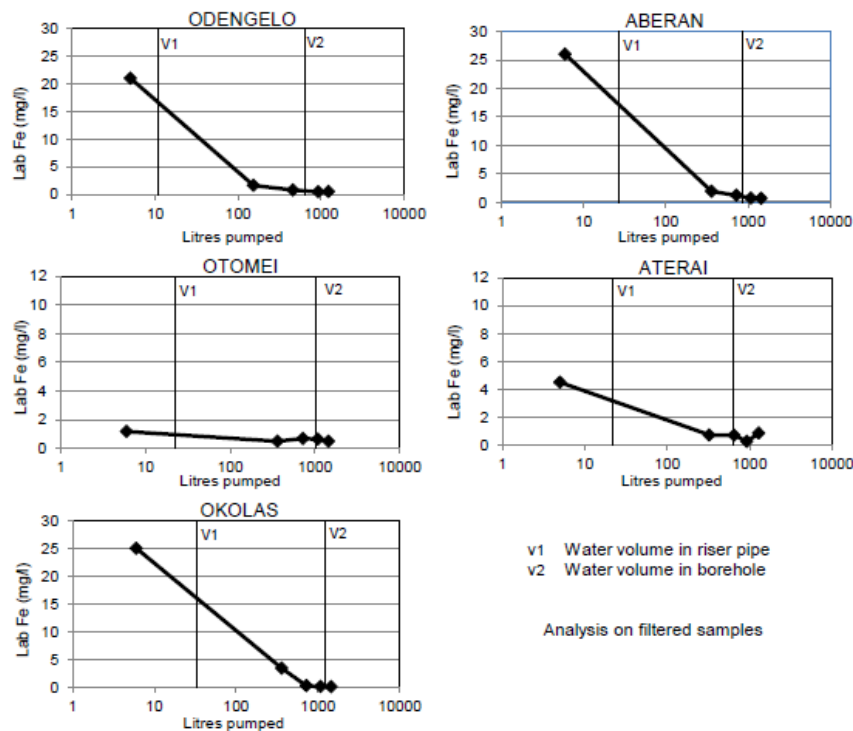

Figure 4. Results of laboratory tests on samples from pumps with GI risers

Iron concentrations recorded from the original water quality testing after construction show that for four of these boreholes the iron concentrations were between 0.08 and 0.68 mg/l. At the fifth borehole, Aterai, a concentration of 13.5 mg/l was measured. This is certainly anomalous when compared to all other samples taken in the district over a 2-year period, but the cause of this is unclear.

When the results from filtered and unfiltered samples were compared it was apparent that filtered samples generally had a lower iron concentration, for example at the Okolas borehole (Figure 5). This may be due to solid corrosion products being removed by filtration, but also to removal of any iron that had precipitated in the short period between sampling and filtering. Nevertheless, the filtered samples clearly show the rapid fall in iron concentration attributable to the removal of iron present due to corrosion of the handpump.

The unfiltered samples from Okolas also show a sudden increase in iron concentration after about 1,000 litres had been pumped, corresponding with an increase in turbidity during pumping. This illustrates how concentrations can be anomalously large if solid corrosion products are present in an unfiltered sample.

SUSTAINABLE GROUNDWATER DEVELOPMENT

Pump Technologies – Solar and Hand-powered

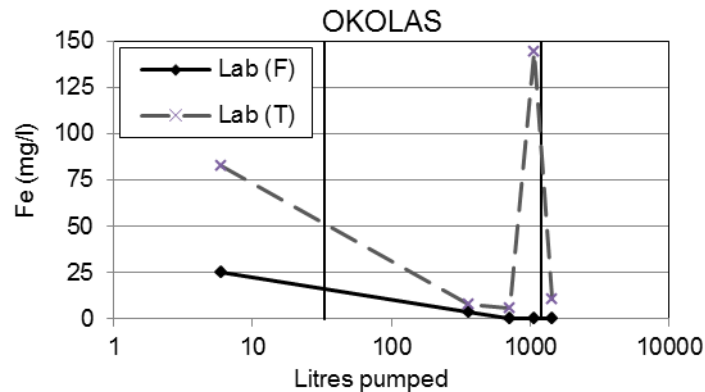

Figure 5. Comparison of laboratory analysis on filtered and unfiltered samples

Three boreholes fitted with PVC riser pipes were also visited (locations shown on Figure 1). These were not tested after being locked overnight so the results cannot be directly compared with those from the India Mk II (U2) installations. Nevertheless, inspection of the pumps and the water quality results are revealing. Two boreholes fitted with U3M pumps (PVC riser and stainless steel pump rods) recorded exceptionally low pH values, between 6.00 and 5.68. The borehole at Amaratot recorded iron concentrations (filtered) of between 1.0 and 1.5 mg/l from the Palintest kit and 1.56 and 2.22 mg/l from laboratory analysis. The second borehole at Abwanget recorded concentrations (filtered) of 0.5 mg/l from the Palintest kit and 0.06 mg/l from laboratory analysis.

The third borehole at Angodingod (Figure 6) was a U2 fitted with 1¼" PVC riser pipe (supplied by Davies and Shirliff, Kampala) and GI pump rods. The Palintest results from two samples indicated iron concentrations less than 0.5 mg/l, confirmed by laboratory results of 0.06 mg/l. A pH of 6.2 was measured in the sample. Overall experience of this installation has been positive to date, and the community has reported an acceptable yield and an absence of coloured water in the early morning, as was the case with pumps with galvanised steel riser pipes.



Figure 6. 1¼" PVC riser pipe fitted to an India MkII pump at Angodingod

## SUSTAINABLE GROUNDWATER DEVELOPMENT

### Pump Technologies – Solar and Hand-powered

The high iron concentrations recorded in the Amaratoit borehole (noted above) appear to be natural given that the pump components are corrosion-resistant. This well had a severe turbidity problem, possibly as a result of a completion which included an inappropriate screened section in weathered deposits. Although the turbidity was not related to corrosion, unfiltered samples tested at the laboratory had iron concentrations of between 3.85 and 4.6 mg/l and one sample a concentration of 45 mg/l.

The following observations can be made from the field testing:

- The Palintest comparator kit performed well at identifying the decline in iron concentration as the well was pumped,
- Iron concentrations from the comparator were slightly higher than those measured at the laboratory, possibly a consequence of the lack of on-site preservation,
- All the samples from boreholes with GI components showed a sharp decline in iron concentration when pumped continuously for two hours. In the final samples, iron concentrations in filtered samples were between 0.17 and 0.86 mg/l.
- The unfiltered samples often showed very high iron concentrations, 144 mg/l in one case, indicating that solid corrosion particles are likely to be present.
- The filters used (syringe filter with 1µm prefilter 25mm, 0.45 µm) were highly effective and did not block. Only in one of the U3M installations (Amaratoit) did turbidity (non-iron related) cause the filters to rapidly clog up. However, the use of on-site filtration does need to be treated with some caution. Filtering may distort the results if there is a rapid alteration of Fe<sup>+2</sup> to Fe<sup>+3</sup> in the time between taking the sample and filtration. In this case the measured iron concentration may be lower than is actually the case. Selecting a larger filter size may compensate for this.
- PVC riser pipes appear to be working effectively at one U2 installation where the pH of the groundwater suggests that corrosion and poor water quality would be a problem if GI pipes were fitted.
- Naturally high iron concentrations were recorded in one of the boreholes fitted with a U3M pump.

During the fieldwork it also became apparent that there was a lack of knowledge regarding the installation and maintenance of the corrosion-resistant U3M pump. Consequently certain installations were not performing optimally.

### Outcomes

Since the research was completed, WaterAid has undertaken a number of actions to address the issues identified:

- The results of the research were presented to a meeting of District Water Officers in 2015 triggering use of stainless steel riser pipes in Amuria District.
- WaterAid Uganda has been advocating the abandonment of the use of GI by partner organisations, particularly where the groundwater is known to be aggressive. Subsequently, all boreholes drilled by partner organisations during 2015 in Amuria District were fitted with U3M pumps (where installation depth was up to 30m) and twenty-six boreholes drilled in the first quarter of 2016 in Amuria, Napak and Kotido Districts were installed with stainless steel components.
- Training courses on the maintenance and installation of U3M pumps has been undertaken in Katakwi and Amuria Districts.
- A number of boreholes in Masindi and Katakwi Districts are being retrofitted with stainless steel components following discussions with the funding organisation (EU).

### Conclusions and Recommendations

## SUSTAINABLE GROUNDWATER DEVELOPMENT

### Pump Technologies – Solar and Hand-powered

At existing handpumps where iron-related water quality problems have been identified, boreholes should be tested to establish whether it has been caused by corrosion of susceptible pump components, or due to naturally high concentrations present in the aquifer. The choice of rehabilitation methods can then be determined.

The influence of bacteria in accelerating pump corrosion was not specifically addressed in the research and this is a potential avenue for further work. An important aspect of this is that bacterially-enhanced corrosion can occur in situations where the pH of the groundwater is  $>7$ . Possible options for avoiding or reducing problems include:

- Use of PVC riser pipes where shallow installation depths are possible
- Use of stainless steel riser pipes and rods at deeper installation depths
- Use of corrosion resistant pumps
- Trialing of the Poldaw PVC/steel coupling riser main configuration
- Ensuring wells are sterilised following completion and following maintenance where the rising main and pump components have been removed, and
- Ensuring good sanitary seals are placed to prevent iron bacteria entering the well after completion.

The main recommendation for preventing the corrosion-induced water quality problems is considered to be improvement to the planning stage of water supply projects:

- Pre-implementation planning for projects must include serious consideration of pH levels using on-site tests. Reference should also be made to government databases and water quality mapping, if available, and treated with the appropriate caution. Communication and coordination with local government and other NGOs working in the area can also reveal concerns about aggressive groundwater. A full assessment should be undertaken to identify problems that may be already known within the project area such as water quality and handpump sustainability, which can have major implications for new boreholes.
- Based on appropriate planning, properly formulated contracts and BoQs are required with sufficient flexibility to allow changes as necessary. Budgets should include sufficient contingency to allow alternative materials to be installed if proven necessary by on-site experience.
- Consideration should be given to separation of the various tasks involved with drilling and pump installation so that the drilling contractor is not responsible for handpump installation or water quality testing. For example, it is not unreasonable to suppose that water quality sampling could come under the responsibility of the project supervisor.

Improvements to the implementation stage include:

- the provision of competent supervision so that specifications are followed
- ensuring water quality testing is undertaken correctly and critical parameters are measured on-site if possible.

Where aggressive groundwaters are known to be present, there should be a focus on communication, data sharing, collaboration, and advocacy among government, private sector, NGOs and communities on the issue of corrosion-resistant handpump options. Sector coordination bodies, such as UWASNET (Uganda water and sanitation network) and NETWAS (Network for Water and Sanitation) in Uganda, could be an appropriate focus for such discussions.

Finally, where the selection of approved corrosion-resistant pumps is limited, stakeholders should advocate for revision of the relevant government standards.

## References

## SUSTAINABLE GROUNDWATER DEVELOPMENT

### Pump Technologies – Solar and Hand-powered

- Arlosoroff, S.; Tschannerl, G.; Grey, D.; Journey, W. and Roche, R. (1987) Community Water Supply: The Handpump Option. The World Bank. Washington, D.C. [www.rural-water-supply.net/en/resources/details/409](http://www.rural-water-supply.net/en/resources/details/409) (accessed 14 Jan 2015).
- Cullimore, D.R. and McCann, A.E. (1978) The identification, cultivation and control of iron bacteria in ground water. Aquatic Microbiology, Skinner and Sherwin Eds. Academic Press. <http://www.dbi.ca/Books/PDFs/Water-Paper.PDF> (accessed 15 June 2015).
- Fader, C.T. (2011) Retrofitting Boreholes Contaminated With Iron in Rural Uganda. MSc thesis. Michigan Technological University. Houghton, Michigan, USA. [www.geo.mtu.edu/~jsgierke/student\\_theses/FaderC\\_MSCEReport\\_RetrofittingWellsContaminatedWith\\_IRB.pdf](http://www.geo.mtu.edu/~jsgierke/student_theses/FaderC_MSCEReport_RetrofittingWellsContaminatedWith_IRB.pdf) (accessed 15 June 2015).
- Furey, S. (2014) Handpumps: where now? - A synthesis of online discussions (2012-2014). Rural Water Supply Network/SKAT Foundation. St. Gallen, Switzerland. [www.rural-water-supply.net/en/resources/details/614](http://www.rural-water-supply.net/en/resources/details/614) (accessed 4 Sep 2014).
- Hoben, G. and Treskatis, C. (2007) Water well rehabilitation and reconstruction. McGraw-Hill.
- Langenegger, O. (1987) “Groundwater Quality - An Important Factor for Selecting Handpumps.” The World Bank. Abidjan, Ivory Coast. [www.ircwash.org/resources/groundwater-quality-important-factor-selecting-handpumps](http://www.ircwash.org/resources/groundwater-quality-important-factor-selecting-handpumps) (accessed 15 June 2015).
- Langenegger, Otto. (1994) Groundwater Quality and Handpump Corrosion in Africa. UNDP-World Bank Water and Sanitation Program. Water and Sanitation Report 8. [www.rural-water-supply.net/en/resources/details/604](http://www.rural-water-supply.net/en/resources/details/604) (accessed 12 June 2015)
- UNBS (Uganda National Bureau of Standards). (2008) US 201:2008. Uganda Standard. Drinking (potable) water – Specification. <https://law.resource.org/pub/ug/ibr/us.201.2008.html> (accessed 18 Jan 2015).
- WHO (World Health Organisation) (2011) Guidelines for Drinking-water Quality. 4th Edition. Geneva: World Health Organization. [www.who.int/water\\_sanitation\\_health/publications/2011/dwq\\_guidelines/en/](http://www.who.int/water_sanitation_health/publications/2011/dwq_guidelines/en/)



## SUSTAINABLE GROUNDWATER DEVELOPMENT

### Pump Technologies – Solar and Hand-powered

---

# Piloting of an Innovative Deep-Reaching and Reliable Hand Pump in Africa for Rural Water Access: The LifePump

---

#### Authors:

Gregory Bixler<sup>1</sup>, Tony Beers<sup>2</sup>, Beatrice Chisenga<sup>1</sup>, David Vader<sup>2</sup> - <sup>1</sup>*Design Outreach*, <sup>2</sup>*Messiah College*

#### Abstract/Summary

Design Outreach (DO) developed a new hand pump called the LifePump™ to alleviate the depth limitations and reliability issues of commonly used standard hand pumps. In partnership with World Vision and The Collaboratory at Messiah College, Design Outreach piloted its LifePump in five African countries, beginning in November 2013. Researchers at Messiah College independently evaluated the LifePump pilot in order to study its field and laboratory performance. The LifePump operates at twice the depth of (up to 100 meters) and requires much less maintenance than standard hand pumps. The design is less prone to sudden failures than standard hand pumps due to its progressive cavity pumping element and heavy-duty components. Additionally, select LifePumps are equipped with SonSet Solutions’ remote satellite monitoring technology that transmits information on pump performance to DO so that it can be monitored via the web. This paper describes the LifePump technology as well as the pilot project context, activities, and implementation strategy.

#### Introduction

Rural inhabitants of developing countries commonly rely on groundwater as their primary source of safe drinking water. Many approaches and technologies have been introduced to access groundwater in regions such as sub-Saharan Africa where poverty and unsafe water is prevalent. Since the Decade of International Drinking Water and Sanitation from 1981 to 1990, appropriate technology has been advocated as one of the key pillars for safe drinking water access. In response, many sub-Saharan African countries have introduced shallow-well pumps (depths up to 10 meters) in addition to deep-well pumps. The commonly adopted hand pumps include the Afridev and India Mark II (IMII), but these “piston-style” pumps have limitations. While these technologies have helped to increase safe water access globally, further technological advances are necessary to continue progressing toward safe water for everyone.

Access to groundwater is based on the hydrogeological environment and the available pumping options. The LifePump impact countries lie within the hydrogeological province with Precambrian basement, volcanic, and consolidated sedimentary rock [1]. A reduction in rainfall across Africa is a key factor that has led to limited or erratic groundwater recharge rates. Global climate change is expected to continue to alter average rainfall and, correspondingly, the recharge rates [2].

Because of these conditions, WASH organizations often must declare boreholes “dry” and leave the well sites if sufficient water is too deep for standard pumps. A dry borehole means a potentially viable well is abandoned, having significant negative economic and human impact. This situation reinforces the need for ultra-deep-well pumping technology beyond 50 meters for rural water supply. The greater a pump’s depth capacity, the greater the subsurface volume of earth available to explore in search of adequate aquifers (with sufficient yield and refresh rates). In other words, the deeper a pump can reach into the ground, the more likely the drilled well will find available groundwater, increasing the likelihood of providing year-round water supply (through both wet and dry seasons). Figure 1 shows the depth comparison of the LifePump (100 meters) to the Afridev (45 meters) and IMII (50 meters) standard pumps.

## SUSTAINABLE GROUNDWATER DEVELOPMENT

### Pump Technologies – Solar and Hand-powered

#### Comparison of Depth Capacity to Standard Pumps

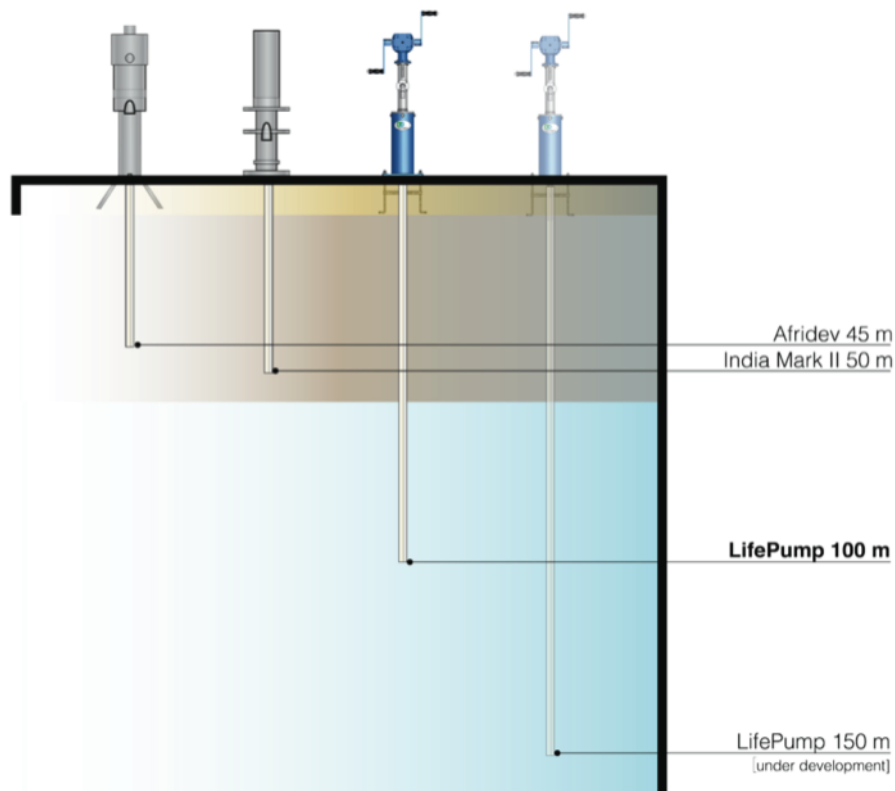

**Figure 3. Depth comparison of the LifePump versus standard hand pumps Afridev and India Mark II. The LifePump currently reaches 100 meters, and a new model that will reach 150 meters is under development.**

Standard pumps often fail to provide a reliable water solution because of inadequate and unreliable pump hardware and a lack of infrastructure [3]. Often, the range of operation of standard pumps, such as the Afridev or IMII, is limited to a depth of 50 meters [4]. In certain cases, sufficient water cannot be found within this range. At sites where water is deeper, pump options are limited and often do not meet user requirements such as flow rate, ergonomics, and durability [5]. Of the nearly 350,000 hand pumps installed in Sub-Saharan Africa prior to 2009, reportedly 125,000 (36%) were no longer functioning [6]. Over the last 20 years, pump failure has translated into US \$1.2-1.5 billion of lost investment [7]. The durability issue is compounded by a lack of infrastructure, including technical support, supply chain, and an ability to pay for operation and maintenance (O&M) [7,8,9]. In an attempt to reduce the infrastructure problem, many countries have adopted standard “open-source” hand pumps like the Afridev or IMII [10]. However, such pumps lack durability [8,9,11], and their supply chains are still inadequate to support timely repairs. For example, a study in Kenya [12] showed that hand pumps fail, on average, twice per year, with an average repair time of 27 days.

### The LifePump

The LifePump operates differently than standard hand pumps. LifePump users rotate handles mounted to a right-angle gearbox that spins the drive rods inside the riser pipes. The bottom drive rod and riser pipe are connected to the rotor-stator assembly called a progressive cavity pump (PCP) element (see Figure 2). The PCP is an auger-shaped, single-helix rotor that turns inside of a double-helix elastomer

## SUSTAINABLE GROUNDWATER DEVELOPMENT

### Pump Technologies – Solar and Hand-powered

stator. As the rotor turns, pockets of water in each cavity are driven to the surface and out the spout. The PCP “lifts” only the water to the surface, while a piston-style pump lifts both the water and the drive rods. Often, children are unable to actuate a piston-style pump without jumping off the ground and using their body weight to push down on the handle. In addition, PCP hand pumps are not prone to catastrophic failure, unlike standard pumps that use pistons for the pumping mechanism. PCPs are able to withstand a high degree of wear and still continue to produce water because of the long seal line between the rotor and stator. Conversely, a piston-style pump relies on a relatively short seal line with O-rings and valves that are prone to failure. PCPs are commonly used in harsh industrial applications that routinely pump suspended solids. Suspended solids, such as sand and silt, may be present in boreholes and so therefore a pump able to withstand these abrasive elements is often necessary.

#### Progressive Cavity Pump Element

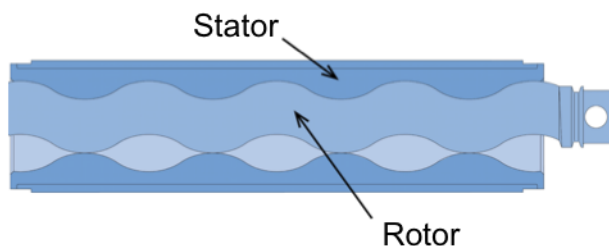

**Figure 4. The Progressive Cavity Pump (PCP) element consisting of the metal rotor and the elastomer stator. As the rotor turns inside the stator, pockets of water are pushed to the surface.**

When comparing the LifePump to other PCP hand pumps, quality, ergonomics, flow rate and handle torque must be considered. Past and present PCP hand pump manufacturers include Mono, Orbit, Cemo, Moyno and Play Pump. Reportedly, Mono, Orbit, and Cemo pumps are considered low-quality because of their design and materials selection [9], Moyno (discontinued in the mid-1980s) was considered reliable but difficult to use by “smaller users” [4], and Play Pump is called “largely inappropriate for community water supplies” due to its “cumbersome and ungainly pumping method” [9]. The flow rate at 100 meters is approximately 2.7 liters per minute (L/min) for Mono, 4.0 L/min for Orbit, 3.2 L/min for Cemo, 5.8 L/min for Moyno, and 10 L/min for the LifePump. Handle torque at 100 meters head is approximately 20% lower for the LifePump as compared with Moyno. The higher flow rates and lower torques are possible due to the high volumetric efficiency (90% at 80 meters, 77% at 100 meters) of the LifePump’s PCP, which is made possible by its design, materials selection, and manufacturing processes.

While other non-PCP hand pumps are available with depth capacities greater than 50 meters (e.g. BluePump, Afridev Bottom Support System, Vergnet HPV100, Poldaw, Duba and IMII Extra Deep), an evaluation of performance, ergonomics, and sustainability by Cornet [5] found them to fall short of end user and WASH organization requirements. For example, the Afridev Bottom Support System experienced similar maintenance and reliability challenges as the standard Afridev, and most women respondents indicated that the BluePump was uncomfortable to use. Further, interviews with African WASH managers have revealed that the “practical” depth of these pumps is less than the maximum depth, because performance and reliability drop considerably as the pumps approach their maximum depth [13]. These pumps are also accompanied by increased actuation force at these depths, negatively affecting ergonomics.

#### Context, Aims and Activities Undertaken

Presently, DO is completing a pilot program in conjunction with World Vision and The Collaboratory at Messiah College that involves installation of LifePumps in Malawi, Zambia, Kenya, Ethiopia, and Mali (see Table 1). The purpose of the pilot program is for Messiah College to independently verify the effectiveness of the LifePump from technological and cultural standpoints. The five countries were chosen based on initial interest by the World Vision National Offices and a need for the LifePump’s depth capacity. The pilot began in Malawi with LifePump installations in November 2013 and expanded

## SUSTAINABLE GROUNDWATER DEVELOPMENT

### Pump Technologies – Solar and Hand-powered

into Zambia, Kenya, Ethiopia, and Mali. Throughout the pilot, DO donated LifePumps to World Vision, and World Vision provided the in-country logistics, community mobilization, and evaluation with Messiah College. DO personnel provided in-field training to each of the countries, including installation and maintenance training to the pump technicians, WASH managers, and government officials. Researchers from Messiah College travelled three times (December 2014, August 2015, and April 2016) to selected LifePump installation sites in the pilot countries (namely Malawi, Zambia, Kenya, and Ethiopia) and gathered ethnographic as well as quantitative pump performance data. The researchers also collected pump hardware from the field for evaluation at Messiah College facilities in Mechanicsburg, PA, USA.

During the pilot program, an instrumented test stand was developed to provide accelerated life testing of LifePump critical components at DO’s research and development (R&D) facility in Sunbury, OH, USA. Accelerated life testing evaluates the pump by exposing its components to higher than normal operating stresses in order to discover any potential failure modes in a relatively short period of time. As shown in Figure 3, the test stand is able to test three pumping assemblies in order to evaluate differing conditions such as simulated depths and water quality as well as pre-screen all pumps before they are installed. Flow rate, torque, revolutions per minute (RPM), back pressure (to simulate depth) and water temperature are continuously sampled and recorded. The system components include data logger (Hobo U30-NRC), pressure transducer (AutomationDirect SPT25-10-0300A), flow meter (Onset T-MINOL-130-NL), load cell (Omega LC302-50), chiller (Aqua-Euro MC-1/2 HP), filter (Culligan HF-150), and electric motor (IronHorse MTR-1P5-3BD18). The motor operates at 45 RPM, which is an average number of handle revolutions per minute by the user, and with the gearbox increaser this translates into 90 RPMs at the PCP. Two of the pumping heads undergo ongoing continuous pump testing, which is comprised of two minutes of pumping with 10-second breaks between pumping cycles. This testing is designed to simulate pumping habits in communities where users will pump for approximately two minutes to fill a 20-liter/~5-gallon container and then transition to the next user. When operating, PCPs can develop a boundary layer of water between the rotor and the stator at approximately 80 RPM. This boundary layer reduces friction, which minimizes the amount of wear between the rotor and stator. To account for this, the pumping heads cycle on and off as indicated.

## SUSTAINABLE GROUNDWATER DEVELOPMENT

### Pump Technologies – Solar and Hand-powered

#### Laboratory Test Stands for Accelerated Life Testing

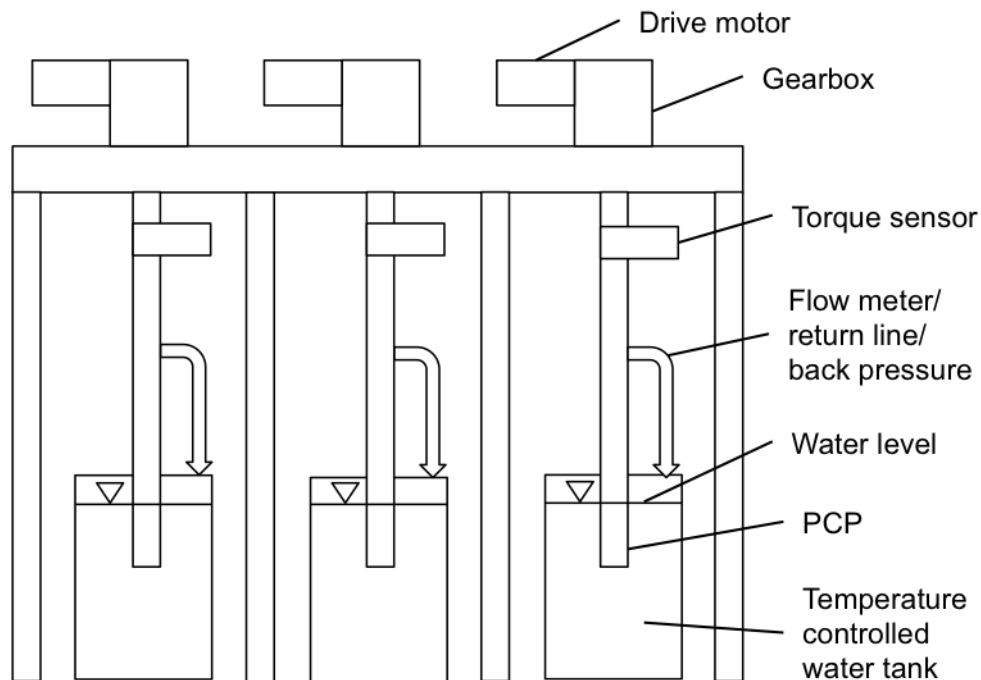

*Figure 5. Laboratory test stand developed for accelerated life testing (4x) at DO's R&D facility in Sunbury, OH, USA. The test stand is capable of simulating real-life pumping conditions. The gearbox, couplers, and PCP element are tested. Water is circulated through a reservoir. Testing is conducted with on/off pumping, backpressure to simulate depth, and water temperature control. A load cell determines torque of the PCP and the flow meter the water flow rate. The system is computer-controlled and runs 24 hours per day, 7 days per week.*

Testing is ongoing, 24 hours per day, seven days per week, giving an assumed 4x accelerated use (assuming six hours of use per day). Preliminary testing revealed an increase in temperature of the water (due to PCP element friction) as it circulates through the water reservoir, raising the water temperature to 90°F/32.2°C. Typical groundwater temperature is much lower, and such an increase in temperature can increase the starting and operating torque of the elastomer stator. To account for this, an in-line water cooler and filter was installed for each of the water reservoirs to maintain a constant temperature of approximately 59°F/15°C, which is the assumed average groundwater temperature in most sub-Saharan African countries.

To demonstrate the PCP's ability to pump from significant depths and maintain its efficiency over time, backpressure is applied to the PCP during the life testing. Deeper wells require the PCP to generate more pressure to overcome gravity, and this increases the PCP torque requirements. This increase in torque imparts more stress on the PCP elements, couplings, and gearbox. These components are part of the test stand assembly and are physically inspected periodically for signs of wear or degradation. Signs of wear are measured by changes in critical dimensions of the rotor and stator, as well as leakage in the gearbox seals. For the backpressure value, an average LifePump depth of 70 meters was chosen for life testing (or approximately 100 pounds per square inch [psi]/689 kilopascals [kPa] backpressure), which is the average depth of most installations. This backpressure is created by restricting the water flow with a valve and is monitored with a pressure transducer.

#### Main Results and Lessons Learned

## SUSTAINABLE GROUNDWATER DEVELOPMENT

### Pump Technologies – Solar and Hand-powered

Provided in this section are the main results and lessons learned from field and laboratory testing beginning in 2013. Results have been collected by a variety of sources, including community members and government officials as well as World Vision, Messiah College, and DO personnel. The LifePumps that are currently installed are listed in Table 1, which also specifies the borehole characteristics of each installation. Pumping tests and pump depths were determined and specified by World Vision hydrogeologists. Evaluations are ongoing, and further reporting is anticipated as data is collected.

Table 1. LifePumps Installed in World Vision Pilot Program

Village name	Location	Direct beneficiaries	Well depth (meters)	Pump depth (meters)	Static water level (meters)	Dynamic water level (meters)	Well commission date
Malawi							
Chilekwa	85 miles NW of Lilongwe	220	97	81	10	51	November 24, 2013
Zolomondo	82 miles NW of Lilongwe	256	63	57	13	52	November 14, 2013
Mynakose	90 miles N of Lilongwe	246	66	60	12	23	May 29, 2014
Mzondi Kasambala	141 miles N of Lilongwe	250	72	60	8	65	June 1, 2015
Vinyanda Chirwa	145 miles N of Lilongwe	121	87	60	8	81	August 8, 2015
Yeremiya Shumba	145 miles N of Lilongwe	250	51	42	13	46	August 9, 2015
Mbiko Shumba	141 miles N of Lilongwe	250	60	45	10	50	August 10, 2015
Zambia							
Kafwikamo Community School	91 miles NW of Lusaka	401	60	40	6	19	December 10, 2014
Big Concession	85 miles NW of Lusaka	472	90	60	16	24	December 9, 2014
Kanundwa School	73 miles SW of Lusaka	250	52	42	10	17	January 23, 2015
Mayanga	512 miles NE of Lusaka	658	40	30	8	14	May 24, 2015
Mateo Village	494 miles NE of Lusaka	146	56	45	14	17	May 26, 2015
Kenya							
Kibau	44 miles E of Nairobi	800	180	100	10	158	September 3, 2014
Kabur	144 miles NW of Nairobi	450	145	100	44	98	December 17, 2014
Buroiyo	161 miles NW of Nairobi	100	100	66	34	85	November 9, 2015
Kinyach	170 miles NW of Nairobi	200	135	66	73	132	October 10, 2015
Shivakala	188 miles NW of Nairobi	500	44	36	10	30	August 19, 2015
Ethiopia							
Gamra Got	303 miles N of Addis Ababa	300	120	63	4	74	March 19, 2015
Kutich	236 miles N of Addis Ababa	300	110	54	55*	78*	September 24, 2015
Minziro-Robit	419 miles N of Addis Ababa	250	70	60	4	n/a	n/a**
Sorsaroha-Mina	403 miles N of Addis Ababa	250	66	57	8	n/a	n/a**
Sekecha-Kamise	271 miles W of Addis Ababa	250 + health center	80	60	15	n/a	n/a**
Mali							

## SUSTAINABLE GROUNDWATER DEVELOPMENT

### Pump Technologies – Solar and Hand-powered

Village name	Location	Direct beneficiaries	Well depth (meters)	Pump depth (meters)	Static water level (meters)	Dynamic water level (meters)	Well commission date
Dombila Flabougou	n/a	n/a	46	28	18	n/a	n/a**
Djinidiebougou	n/a	n/a	54	33	11	n/a	n/a**

\*reported values; during installation, the pump was installed below the static water level

\*\*the official well commission date TBD, but each pump was installed June-July 2016

### Initial Field and Laboratory Results

Early volumetric efficiency data for two sites in Malawi, namely Chilekwa and Zolomondo, are shown in Figure 4 and demonstrate consistent performance from November 2013 through November 2014 [13]. The table shows the total number of handle rotations needed to fill a 20-liter/~5-gallon container over time. These initial results indicate that pump performance remained constant for the first year of operation, and the most recent site visit to these communities in April 2016 (30 months of constant usage with no repair or maintenance) indicated that flow rate performance remained unchanged.

To continue monitoring pump performance in real time, several LifePumps in Malawi, Zambia, Kenya, Ethiopia, and Mali are outfitted with spout-mounted satellite-based remote data loggers created by SonSet Solutions (Elkhart, IN, USA). These units record daily usage information and transmit the data wirelessly via satellite to DO for analysis (see examples from Malawi and Zambia in Figure 5). Total gallons pumped per day are calculated using efficiency information collected from the well site shortly after installation and the number of handle rotations for a given day. With regard to the laboratory testing, Figure 6 shows data (first 700 hours) from an example PCP that has been under testing for three months (4x accelerated life equating to approximately one year of community use). Data indicates consistent pumping performance with constant temperature, backpressure, and torque control. Temperature stayed constant at an average of 58.5°F /14.7°C.

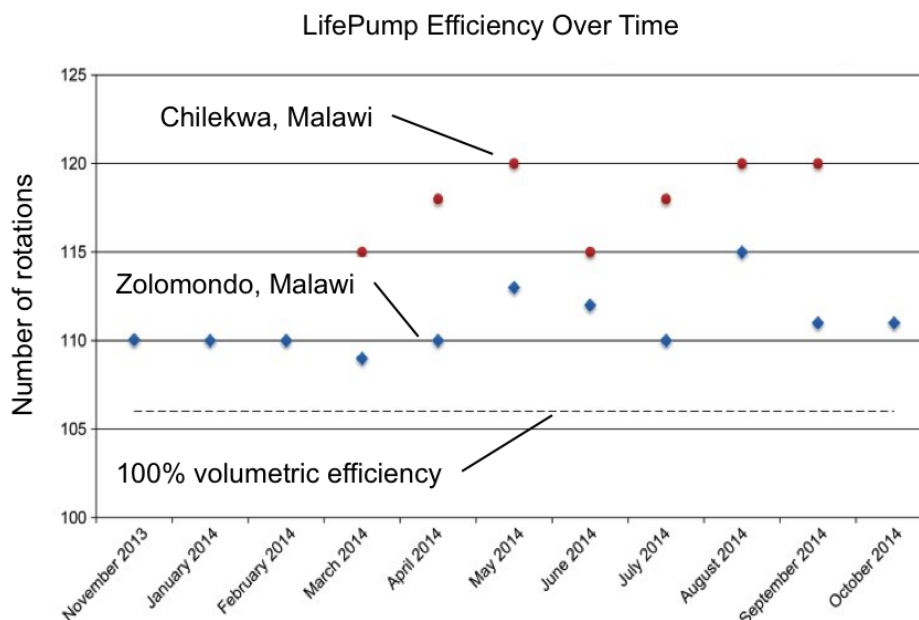

SUSTAINABLE GROUNDWATER DEVELOPMENT

Pump Technologies – Solar and Hand-powered

Figure 6. LifePump efficiency data collected from two communities in Malawi during the initial test phase of the LifePump pilot. The graph shows handle rotations required to pump 20 liters/~5 gallons. The 100% volumetric efficiency is shown, indicating a slight drop in efficiency as depth increases. The pump depths of Zolomondo and Chilekwa are 57 and 81 meters, respectively.

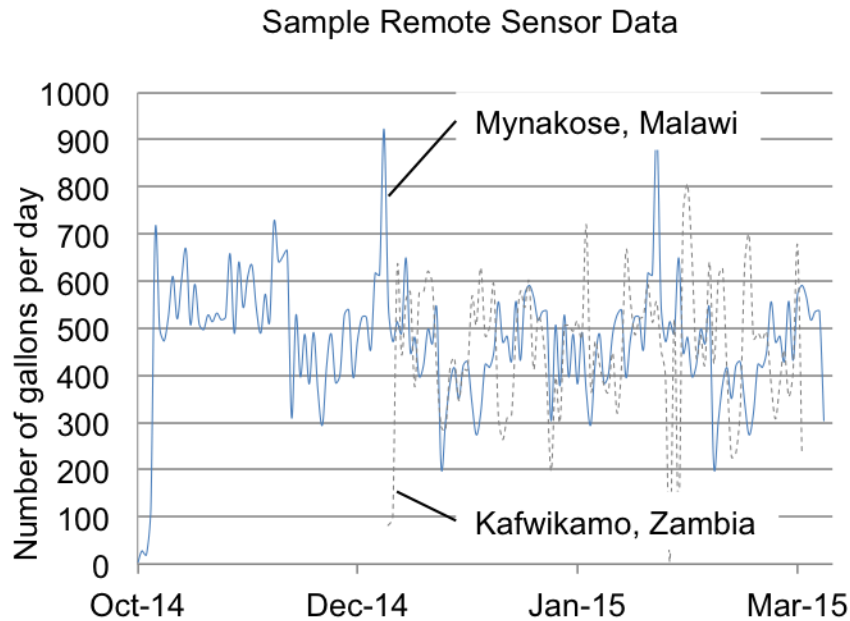

Figure 7. Satellite-based remote monitor data collected from two communities in Malawi and Zambia. The graph shows the number of gallons pumped per minute based on pumping efficiency and the number of handle rotations. This data is collected daily through satellite transmission and can be used by WASH organizations' monitoring projects.

Laboratory Testing Results

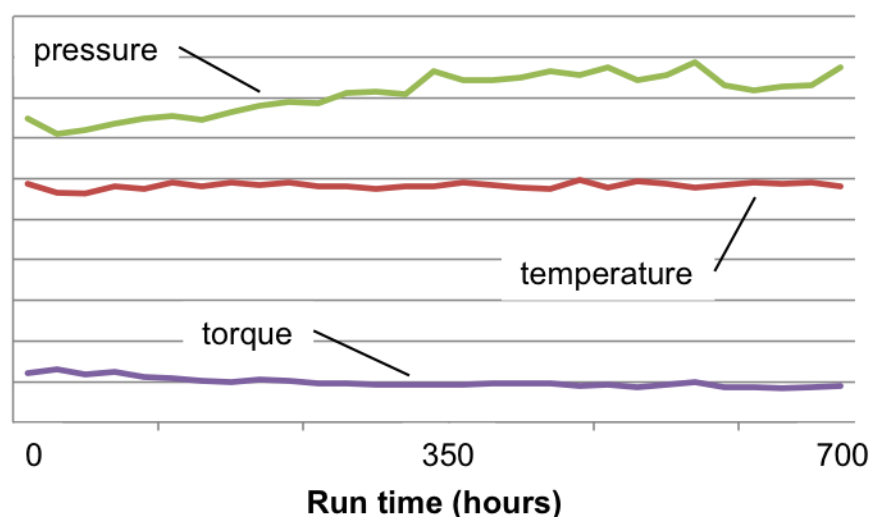

Figure 8. Laboratory test stand data for accelerated life testing of critical LifePump components. Results show the consistent water temperature, PCP element torque values, and flow rate. Testing conditions simulate 70 meters of depth. A comparison of results to field data validates the laboratory testing.



## SUSTAINABLE GROUNDWATER DEVELOPMENT

### Pump Technologies – Solar and Hand-powered

#### Initial Field Evaluation Results

This section provides data collected by researchers from Messiah College during field evaluation trips to Malawi and Zambia in December 2014 and August 2015 as well as Zambia, Kenya, and Ethiopia in April 2016. Also included are World Vision and Design Outreach evaluations from trips to Zambia and Kenya in June 2016 and Mali in July 2016. These findings are part of the preliminary learning that provides feedback for improvements and future recommendations. In summary, the LifePumps were found in good operating condition, and a summary of findings with highlights from observations is found below.

In Malawi, three LifePumps were visited in the Kasungu district, namely in the communities of Zolomondo, Chilekwa, and Mnyakose. All of the pumps were found in operational condition. Figure 7 shows the first LifePump installed as part of the World Vision pilot program. This pump in Zolomondo and another in Chilekwa have been operational since November 2013 without any maintenance or repair. Ten community members were interviewed at Zolomondo and Chilekwa, and seven were interviewed at

#### First LifePump Installed in Zolomondo, Malawi



*Figure 9. The first LifePump in Malawi was installed November 2013. The borehole was too deep for an Afridev and was declared dry until the LifePump arrived and could reach the water.*

Mnyakose. Community members answered questions related to sustainability, flow rate, ergonomics, and durability. An effort was made to capture a rough translation of the community members’ comments even if the question format was multiple choice. Furthermore, video was taken to capture user interaction with the LifePumps, which was analysed with regard to acceptance and ergonomics.

In Zambia, three LifePumps were visited, two near Mumbwa (Big Concession and Kafwikamo Community School) and one in Monze (Kanundwa School). The pumps in Mumbwa were found in operational condition, while the pump in Monze was found to have a minor gearbox oil leak that allowed oil to drip into the riser pipe. The children only used the water for bathing and washing clothing. Even though the oil is food grade safe, the community decided not to drink the water due to a perception that the oil is unsafe. The LifePump at Kafwikamo Community School had a handle grip that was stuck. The grip was repaired by removing it and sanding away the corrosion and grime that had impeded rotation. It should be noted that the pump continues to operate even if the grip seizes. Ten community members were interviewed at Big Concession and Kafwikamo Community School, while only two were interviewed at Kanundwa School. As in Malawi, an effort was made to capture a rough translation of the community members’ comments, even if the question format was multiple choice.

In Kenya, five LifePumps were visited, namely in the communities of Katithi, Buroiyo, Kinyach, Kapingi, and Killboti.

All of the pumps were in operational condition but experienced some community mobilization deficiencies. In Katithi, community members believed the water was unsuitable for consumption due to high levels of iron. They reported that they really wanted an electric pump with a tank and distributed water supply as initially promised during the assessment phase.

However, after learning that the water was safe and that the borehole was unfit for an electric pump, the community was

satisfied with the LifePump. Two other LifePumps received positive ratings (Kapinigi and Killboti), and two received complaints of high handle torques (Kinyach and Buroiyo). Further investigation revealed that these complaints of higher torque values were not design-related; instead, negative perceptions of the

## SUSTAINABLE GROUNDWATER DEVELOPMENT

### Pump Technologies – Solar and Hand-powered

water quality prevented regular usage, so the pumps were never “broken in.” For instance, reports show that Kinyach runs dry and Buroiyo’s water has high iron content, which deters community members from using the pump. The cause of the dry borehole in Kinyach was related to miscalculation of dynamic water levels during the installation phase. Both negative experiences were not related to the LifePump hardware.

In Ethiopia, two LifePumps were visited, namely in the communities of Gamra Got and Kutich. The Gamra Got pump was vandalized, resulting in a missing handle and debris in the spout. Further investigation indicated that the community was expecting an electric pump, but when the borehole was deemed insufficient, the LifePump was installed. This was not the expectation of the community, and they rejected the hand pump. Furthermore, the LifePump was found to be installed on disputed land. The Kutich LifePump was found in operational condition but locked because the borehole ran dry. The remaining three LifePumps were recently installed (incorporating lessons learned from the first two), and follow-up monitoring trips are in process.

In Mali, the latest country to receive LifePumps, two LifePumps were recently installed in Dombila Flabougou and Djiniébougou. These communities provided positive initial feedback, and follow-up monitoring trips are in process.

#### Structured Interview Data

In general, comments from community members, World Vision WASH personnel, and area mechanics were very positive. For instance, they appreciated the increased depth capacity, that components are durable, and that “pumping the LifePump is not a very hard job.” Overall, the LifePump is well-received, scoring an average rating of 3.7 out of 5 based on survey responses taken during Messiah College’s visits regarding user comfort while operating the LifePump. All users surveyed claimed to have had experience with at least one other pump type. When asked to compare the LifePump to other pumps they have used, 88% preferred the LifePump overall, with 65% of those interviewed claiming that the LifePump is easier to use than other pumps. Despite this, 63% felt that the flow rate was low compared with other pumps, and 18% found pumping to be tiresome. When asked what improvements they would like to see made to the LifePump, 55% suggested making the handles easier to rotate, while 46% suggested a higher flow rate. It should be noted that the LifePump flow rate is almost identical to that of the Afridev or IMII at their maximum depth, but these are perceptions of communities with deeper water averaging a depth of 70 to 100 meters.

Twenty percent of those surveyed indicated that they have a medical condition or are pregnant. Of those respondents, 40% were pregnant, and another 40% indicated having hypertension. Eighty percent of participants who claimed to have a medical condition indicated that this had a negative effect on their ability to use the pump: 40% reported feeling tired, and 30% reported needing assistance. Other effects noted were a need for breaks while pumping, body aches, and heart palpitations.

From an implementer perspective, World Vision WASH personnel commented on the LifePump. They considered the LifePumps easy to install and reported that the LifePump met their need for a deep and reliable pump. They appreciated that the LifePump can reuse the IMII base stand in a retrofit situation. In countries with IMII, initial installation was quicker because the area mechanics are already familiar with metal riser pipes. A commonly cited benefit of the LifePump riser pipe was the fact that no tools are required and that the galling risk is reduced due to the LifePump’s drive rod and riser pipe designs. Table 2 lists general observations for areas of improvement as well as actions taken as an outcome of the pilot program.

*Table 2. General Observations for Areas of Improvement*

General observations/feedback	Actions taken
Oil has been seeping slowly from the bottom of the gearbox housing.	The gearbox was redesigned to accommodate food-grade grease instead of oil to avoid this situation.

## SUSTAINABLE GROUNDWATER DEVELOPMENT

### Pump Technologies – Solar and Hand-powered

General observations/feedback	Actions taken
Handle grips become unable to rotate on the handle.	The handles were redesigned with a stainless steel stud to prevent corrosion and handle sticking.
Retrofitting an IMII requires removing the concrete base.	The pump was redesigned to accommodate the standard IMII base as the LifePump base.
Pump prime leaks slowly, requiring two handle rotations to start producing water during the day.	The foot valve was redesigned with a guard to prevent potential damage during installation.
Approximately four to five Afridev pumps can be installed in a day, while the LifePump requires one day per pump.	New LifePump riser pipe currently available does not require wrenches, which saves significant installation time. Installation with experienced operators can be accomplished in less than 3 hours.
Some users prefer a higher volume of water per rotation to be produced.	DO is working to increase volumetric efficiency of the PCP, which will produce more water for the same amount of input energy. DO also is working on a PCP design that will increase the depth capacity.
Some users, including children, would benefit from a reduced pump height, and those with disabilities would benefit from a seat.	Ergonomic trade-off studies indicate that the LifePump accommodates the majority of women and children users. A seat or concrete step near the pump could help accommodate more people.
It was recommended that DO provide spare parts during the pilot phase.	Spare part kits were sent to World Vision for each installed pump. Presently, a franchising model for parts and service is being developed.
It was recommended that DO consider compatibility of IMII riser pipes.	The pump was redesigned to accommodate IMII riser pipes.
Some drive rod couplers experienced galvanic corrosion.	The couplers were redesigned with a new material to prevent the galvanic corrosion.

### Quantitative Handle Torque Data

Two sets of torque data were collected from each LifePump, namely using one hand (see Table 3) and using two hands (see Table 4). The torque was measured using a torque sensor (Futek Sensit model TRS300) with a sample rate of 100 samples per second for the duration of time required to fill a 6-gallon/23-liter container. Each test was repeated five times. For both experiments, the flow rate and mean torque were tabulated. For the one-handed case, the starting torque also was recorded. This represents the initial short “static” torque required to start pumping. The starting torque was indistinguishable in the two-handed experiment. All curves were sinusoidal in nature.

Data corresponds to laboratory test stand and ergonomics data and is generally consistent between sites. For instance, the deeper wells (with an average well depth of 70 meters) show a higher average handle torque, with a range for one-hand operation of 12.4 to 17.3 ft-lbs or 16.8 to 23.4 N m. Values for two-hand operation are expected to be about half, which is the case. The exception is Kanundwa School where the depth is less than that of the other Zambian communities, and yet the torque is slightly higher. Measurement error may play a role (torque tolerance of +/- 5%). Starting torque is the peak torque required to overcome static friction and to start pumping, and users were able to provide enough initial power. Users turn the handles an average of 40 to 50 RPMs, and the average flow rates correspond to PCP manufacturing specifications. All the values are within the tolerance range of the PCPs and are considered ergonomically correct for the majority of users.

## SUSTAINABLE GROUNDWATER DEVELOPMENT

### Pump Technologies – Solar and Hand-powered

Results suggest that laboratory and field torque and flow rate values are similar when comparing Table 3 to Figure 6 torque values, validating the test stand equipment. Torque shown in Figure 6 represents the rotor torque, and Table 3 represents total handle torque. Values are within 15% of each other. Additionally, Figure 6 shows the break-in period of the PCP, with field-testing experience indicating that initial break-in occurs typically within 24 to 48 hours of installation (5 to 6 hours of actual pumping).

Table 3. One-Hand Pumping Data

Community	Well Depth (m)	Flow Rate (L/min)	Starting Torque (ft-lb/N m)	Average Handle Torque (ft-lb/N m)
Chilekwa	97	11.5	21.7 / 29.4	13.7 / 18.5
Zolomondo	63	10.9	19.6 / 26.6	12.4 / 16.8
Mnyakose	66	11.2	23.4 / 31.7	12.6 / 17.1
Kafwikamo School	60	10.4	37.2 / 50.4	15.0 / 20.3
Big Concession	90	9.5	29.8 / 40.4	17.3 / 23.4
Kanundwa School	52	10.4	33.8 / 45.8	15.6 / 21.1
Average	~70	10.6	27.6 / 37.4	14.4 / 19.5

Table 4. Two-Hand Pumping Data

Community	Well Depth (m)	Flow Rate (L/min)	Starting Torque (ft-lb/N m)	Average Handle Torque (ft-lb/N m)
Chilekwa	97	11.7	21.7 / 29.4	7.7 / 10.4
Zolomondo	63	10.4	19.6 / 26.6	6.1 / 8.3
Mnyakose	66	12.1	23.4 / 31.7	5.0 / 6.8
Kafwikamo School	60	11.5	37.2 / 50.4	8.9 / 12.1
Big Concession	90	9.6	29.8 / 40.4	8.9 / 12.1
Kanundwa School	52	13.8	33.8 / 45.8	9.1 / 12.3
Average	~70	11.5	27.6 / 37.4	7.6 / 10.3

### Conclusions and Recommendations

A pilot program was conducted by World Vision, Messiah College and Design Outreach to study the feasibility of the LifePump in five countries. Design Outreach and World Vision also have involved Ministry of Water officials in each of the pilot countries at various levels. The LifePump pilot program has provided valuable insight into how this new technology can help communities. Qualitative and quantitative results were collected on 24 LifePumps installed in Malawi, Zambia, Kenya, Ethiopia, and Mali. Data was also collected from laboratory test stands and using remote monitoring technology. The longest-running LifePumps are found in Malawi and were installed in November 2013. To date, these pumps have experienced no need for repair or maintenance.

This study found that when community members compared the LifePump to standard hand pumps, they preferred the LifePump because of its high durability, reduced maintenance, and ease of use. Independent analysis of LifePump components, such as the PCP and gearbox, revealed that the LifePump showed no measureable signs of wear on critical components after 30 months of daily usage. Perceptions that the flow rate is lower than Afridev or IMII are due to pumping at different depths (when comparing at the same depth, LifePump flow rate is similar to Afridev or IMII). Some minor improvements have been made to the LifePump design based on lessons learned during the pilot program. These modifications include using a grease versus an oil-filled gearbox, adopting the IMII base stand, incorporating a drive rod coupler material resistant to galvanic corrosion, and improving community mobilization, including supervision and monitoring processes.

## SUSTAINABLE GROUNDWATER DEVELOPMENT

### Pump Technologies – Solar and Hand-powered

The success of the LifePump depends on proper community mobilization as evidenced by discrepancies in community perceptions of the LifePump. Upon investigation, the few negative perceptions were the result of perceived poor water quality, dry boreholes, and/or the expectation of an electric pumping system. These factors are deemed non-design related with regard to LifePump performance. The highest social acceptance of the LifePump is found in communities with a retrofit where they experience first-hand the reliability of LifePump as compared with Afridev and IMII. The lowest social acceptance of LifePump is found in communities that are expecting or promised something else (such as an electric pump or piped water system) but instead receive a LifePump.

In conclusion, the LifePump is an encouraging new innovative option for water access that should be considered by the WASH community. The pilot program shows promising community acceptance, durability and cost effectiveness—helping to lead to improved sustainability.

### Future Plans

With the guidance of NGO partners, relationships with NGOs and government officials in Malawi, Zambia, Kenya, Ethiopia, and Mali have been established and are being further solidified. Supply chains are being developed with public (government), private, and NGO partners. A base of distributors and service technicians is being developed to provide in-country presence and accelerated market growth. DO's general strategy in Africa is to obtain necessary governmental approvals and develop in-country distribution through a proposed LifePump franchising model that expands existing pump supply chain partners. Such franchisees will sell, install, and service LifePumps. DO will facilitate or encourage LifePump support by the franchisee or project sponsors to align with the specific country community management models, which include forging partnerships with stakeholder end users and their coordinating local government committees. DO also will encourage LifePump operations to incorporate input and technical advice from hydrogeologists, particularly during the drilling phase. Such geologists will be advisors to LifePump project sponsors/drillers, providing input for locating favourable sites as they explore year-round groundwater resources.

### Acknowledgements

Many people have given generously their time, talents, and resources to make the LifePump possible. These contributors include the volunteers, donors, and many partner organizations that believe safe water should be available to every person, every day of the year. Special thanks also goes to World Vision for their early partnering and shared investments in the LifePump pilot program. This includes the World Vision Innovation Fund that was able to provide Messiah College's independent evaluation.

### References:

- 1.) MacDonald, A.M. and Calow, R.C. (2009), “Developing groundwater for secure water supplies in Africa,” *Desalination*, 248, 546-556.
- 2.) Hulme, M. and New, M. (1997), “Dependence of Large-Scale Precipitation Climatologies on Temporal and Spatial Sampling,” *Journal of Climate*, 10, 1099-1113.
- 3.) Chilton, J. (2014), "A Hidden Crisis: unraveling the causes of failure in rural groundwater supply," RWSN Webinar Series, UPGro, NERC.
- 4.) The World Bank (1984), "Laboratory Testing of Hand Pumps for Developing Countries," The World Bank, Washington DC, USA.
- 5.) Cornet, L. (2012), "A Comparative Evaluation Of Ultra Deep-Well Hand pumps Cranfield University," MSc Thesis.
- 6.) "Hand pump Data 2009. Selected Countries in Sub-Saharan Africa," RWSN, St Gallen, Switzerland (2009).

## **SUSTAINABLE GROUNDWATER DEVELOPMENT**

### **Pump Technologies – Solar and Hand-powered**

- 7.) Baumann, E. (2009), "May-day! May-Day! Our handpumps are not working!" RWSN Perspective No 1, RWSN, St Gallen, Switzerland.
- 8.) Colin, J. (1999), "VLOM for Rural Water Supply: Lessons from Experience. Task No: 162," WEDC, Loughborough University, Loughborough, UK.
- 9.) Parry-Jones, S., Reed, R., and Skinner, B.H. (2001), "Sustainable Hand pump Projects in Africa," WEDC, Loughborough University, UK.
- 10.) MacArthur, J. (2015), "Hand pump Standardisation in Sub-Saharan Africa: Seeking a Champion," RWSN Publication 2015-1, RWSN, St Gallen, Switzerland.
- 11.) Furey, S.G. (2013), "RWSN Hand pump Survey 2013, Rural Water Supply Network/Skat Foundation," St. Gallen, Switzerland.
- 12.) Oxford/RFL (2014), "From Rights to Results in Rural Water Services – Evidence from Kyuso, Kenya," Smith School of Enterprise and the Environment, Water Programme, Working Paper 1, Oxford University, UK.
- 13.) Bixler, G., Stathulis, S., Haubert, T., Lakovic, D., and Sivandran, G. (2015), "The LifePump Innovation for Developing Countries," Journal AWWA, 107:5, 48-54.

## SUSTAINABLE GROUNDWATER DEVELOPMENT

### Pump Technologies – Solar and Hand-powered

# What cost a forgotten History? Implications of Groundwater Quality on Hand Pump Standardisation in Uganda

*Alan Reade, GOAL*

## Abstract

In recent years there has been an increasing awareness, amongst sector actors, of handpump corrosion and iron contamination issues across Uganda. Since 2014, GOAL has been collaborating with other actors to establish the scale of the corrosion and iron issue across the country. Much of the formative research in this field was conducted as early as the late 1980s when research and field experience clearly showed that galvanised iron (GI) was not suitable for installation in aggressive groundwaters (pH<6.5). Using this as a benchmark together with data from the Directorate of Water Development, GOAL was able to confirm that approximately 30% of all groundwater was aggressive and not suitable for the installation of GI materials – as per the National Standard for handpump selection. This finding poses a number of issues for the government and implementation partners. The issues together with possible responses and consequences are presented in this paper.

## Introduction

Approximately 82% (28.4 million) of Ugandan population is classed as rural. The vast majority rely on hand pumps to access to their daily water supply. The Government of Uganda (GoU) 2015 Sector Performance Report states that of the rural population with access to improved water (currently just 65%) nearly 66% rely on boreholes and shallow wells, which implies that some 12.2 million people are reliant on hand pumps on a daily basis.

Functionality of rural water points across Sub Saharan Africa has been reported by others<sup>43</sup> to be in the region of 65%. In Uganda the level of functionality reported by the government is somewhat better than this and as of 2015 Sector Performance Report stood at 88% (varying across districts from 58% to 98%) - though the true figure is likely to be less than this as this figure includes functioning boreholes that have been abandoned (presumably due to poor water quality).

Non functionality due to technical breakdown is reported as the most common cause of failure. Whereas these can be caused by multiple types of failure, corrosion appears to be one major cause. Corrosion of handpump parts is important as it can lead to pump abandonment in a number of ways:

1. Corrosion can cause technical breakdown of the pump which is beyond the capacity or financial means of the community to repair.
2. Corrosion can result in high iron in the water leading to taste issues and discolouration of food and laundry.
3. Corrosion leads to a repeated rapid corrosion and replacement cycle which eventually wears down the resolve of the water committee and community to keep replacing parts.

As early as the mid-1980s research was being undertaken as part of the World Bank Handpumps Project, which analysed groundwater quality and handpump corrosion in the West African sub region. In 1987 Otto Langenegger first published his findings from the rigorous laboratory and field research of the project that had been undertaken across five countries in West Africa. The complete findings were later published in the synthesis works of 1994<sup>44</sup>. In these papers Langenegger makes some very critical statements which should have had a significant impact on the selection of hand pump materials but seem to have been forgotten over time.

<sup>43</sup> RWSN (2009) *Handpump Data 2009*.

<sup>44</sup> Otto Langenegger 1994; *Groundwater Quality and Handpump Corrosion in Africa*

## SUSTAINABLE GROUNDWATER DEVELOPMENT

### Pump Technologies – Solar and Hand-powered

Langenegger reported that despite corrosion being a highly complex process that was difficult to predict with any level of confidence, groundwater pH did appear to offer some guidance as a corrosion index – particularly with regard to galvanised iron pump rods and riser pipes.

He determined that in moderately aggressive groundwater (pH<6.5) the zinc coating is stripped off in a matter of months. Figure 1 below is taken from Langenegger and shows concentration of zinc and iron over a year in 2 boreholes with aggressive ground water.

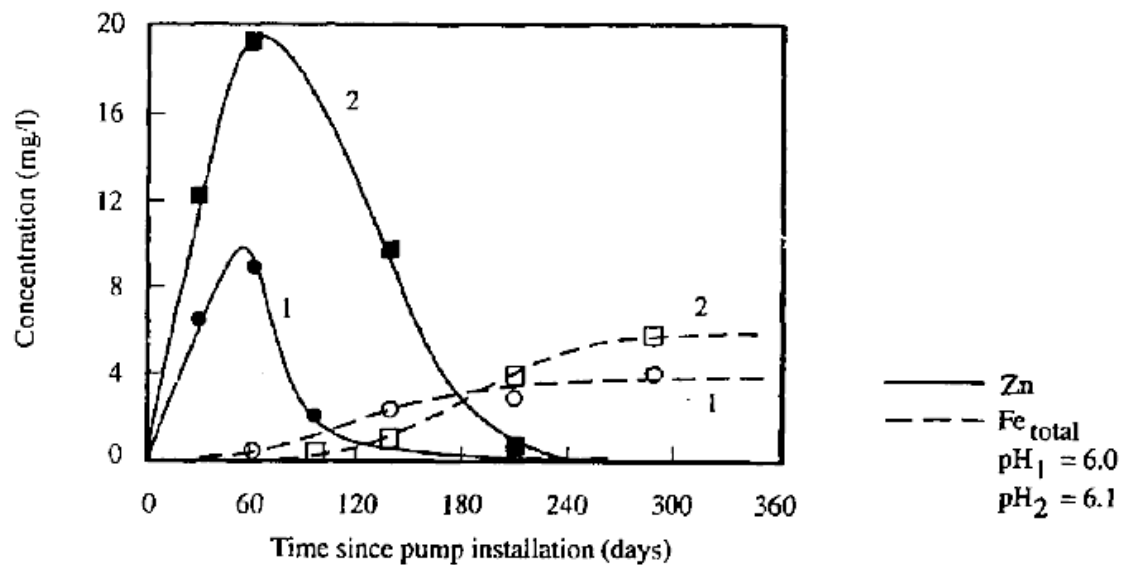

**Figure 1. Zinc (Zn) and total iron ( $Fe_{total}$ ) concentrations in groundwater versus time since installation of two non-corrosion-resistant handpumps (Moyno with galvanized rising mains and pump rods; Cote d'Ivoire). The iron concentration increases after the zinc peaks; that is, as soon as the protective coating (galvanization) is no longer intact.**

The significance of this is that for aggressive groundwaters (pH<6.5) the quality of the galvanising has little to no impact on protection from corrosion. In the tests above the GI pipes were of high quality conforming to ANSI standards.

Independently, at a similar period in Uganda, the RUWASA project was learning from its own large scale hand pump installation project which was being implemented in the East of Uganda. The RUWASA (Phase I) project ran from 1991 until 1996 and was funded by DANIDA to the tune of \$35,000,000<sup>45</sup>. During the initial phases of installation, community feedback brought their attention to the severe corrosion issues experienced in the new installations. Within 19 months of starting, the project switched from GI to stainless steel. The programme switched initially to 304SS but a year later to 316SS which has greater resistance to corrosion<sup>46</sup>.

#### Handpump Standardisation

Around the same time, many Sub-Saharan countries had been grappling with the issue of handpump standardisation. Some opted for full formalised standards (such as Uganda) and others preferring to use less binding and more flexible approaches such as recommendations or endorsements. Although there are pros and cons for each of these approaches, it is clear that the intention of hand pump standards was to limit the number of different models used in a country, thereby simplifying supply chains and making it

<sup>45</sup> N. Asingwiins, D. Muhangi, July 1997, An Analysis of the Impact of Institutional Rules on Rural Water Sustainability. Uganda Country Report

<sup>46</sup> Baumann 1998, Handpump Technology Input to the Joint Review of the Rural Water Supply and Sanitation Eastern Uganda Project- RUWASA Phase II A



## SUSTAINABLE GROUNDWATER DEVELOPMENT

### Pump Technologies – Solar and Hand-powered

easier and more affordable to access pumps, spares and supplies for the rural communities. Whilst at the time there was widespread support for standardisation from the sector, there has also been increasing concern, more recently, leading to a largely polarised view on the benefits and constraints caused by pump standardisation. Apprehensions around standardisation include: monopolisation of the market; stifling of innovative and low cost technologies; lack of incentive to improve the quality of pumps; and possible unsuitable technology selections<sup>47</sup>.

Despite the evidence being published at the time, the government of Uganda decided on a hand pump standardisation strategy based on the India MkII and Mk III hand pumps (referred to as the U2 and U3 in Uganda) with GI riser pipes and connecting rods. The Standard was formally adopted in 1999.

In the Uganda standards provision is made for corrosion resistant materials (stainless steel) in the U2/U3 pumps, however the criteria for triggering their use (pH<5.5) are significantly lower than the recommendations of Langenegger or what experience from the field would suggest was appropriate. The following table shows the criteria for material selection as stated in the standard:

Water Quality	Connecting Rods	Riser Pipes	Cylinder
- pH value 5.5 or more - Oxygen level 2mg/ltr or less	Galvanised Mild Steel (GI)	Galvanised Mild Steel (GI)	Cast Iron with Brass Liner
- pH value 5.5 or Less - Chloride level up to 200mg/ltr	Stainless Steel AISI 304	Stainless Steel AISI 305	Cast Iron with Brass Liner or SS AISI 304
- pH value 5.5 or Less - Chloride level up to 200mg/ltr	Stainless Steel AISI 316	Stainless Steel AISI 316	Cast Iron with Brass Liner or SS AISI 316

Table 1. Hand Pump Material Selection for Different Water Qualities (Extract from Annex B to the Shallow Wells Handpump (U2/U3) Standard Specification, 1995)

Subsequent to the original standards there were additional modifications of the U3 to further address the corrosion issues by introducing corrosion resistant materials and creating the U3M (M= modified).

In the years that followed the government and organisations continued installing the U2 and to a much lesser extent, the U3 and U3M – in accordance with the government standards. As emphasis for much of the intervening years was largely on access rather than maintenance, the corrosion issues seem to have been largely forgotten.

#### Corrosion issues re-surface 20 years later

GOAL Uganda has been working in the south east of Uganda since 2011. In 2014 a new water access project commenced working to increase water access in four sub-counties of two districts (installing new boreholes with the India MkII - in accordance with the national standards). During routine monitoring in one of the districts the following year, communities started to complain of iron issues and corroded pipes. Surprised at the speed of corrosion, GOAL started an investigation as to the cause. A review of the pH of the groundwater at 44 new boreholes indicated that approximately 65% were installed in aggressive ground waters (pH<6.5).

GOAL Uganda leads an informal Rural Water Supply O&M Practitioner’s Forum which meets quarterly in Kampala. The issues of corrosion and Iron were shared at the forum and clearly had much resonance with participants. Several organisations agreed to share their own data for analysis, in an effort to establish the scale of the issue in Uganda. Anecdotally it seemed as though the problem was widespread – but what was really needed was hard evidence to enable the scale of the issue to be understood and to guide future discussion with the government. Data from other organisations was collected and analysed for pH. It showed that the proportion of boreholes sited in aggressive ground water was around 34% (from 800 data points).

Although this data did indeed indicate that there may be a significant corrosion risk across the country, the data sources available<sup>48</sup> were still clustered in small areas and did not cover the whole country. A request to the Directorate of Water Development (DWD) resulted in access to the water quality database used to develop ground water quality maps for various districts within the country. Some 29,000 data sets were shared in total, but these included both surface as well as ground water sources. After filtering the

<sup>47</sup> Jess MacArthur, 2015; Handpump Standardisation in Sub-Saharan Africa.

<sup>48</sup> These data points were supplied by a number of organisations which they had collected through their own research or monitoring. This was not from specific research to address this issue – but was just data that was available at the time of the investigation.

SUSTAINABLE GROUNDWATER DEVELOPMENT

Pump Technologies – Solar and Hand-powered

data for boreholes and shallow wells together with pH data, some 8200 data sets remained. Although not every district was represented the data still provided significant coverage across the country as can be seen in the figure below:

Map of Uganda Showing Extent and Distribution of Data Set (8200 point from DWD)

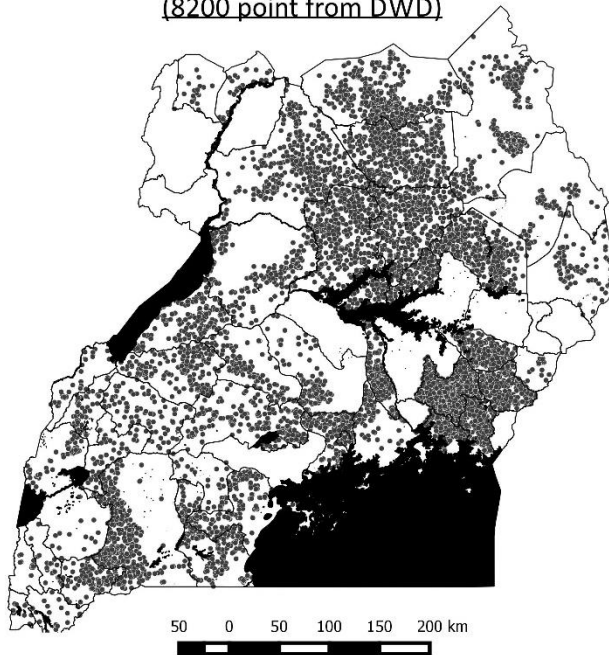

Figure 2 Map showing Extent and Distribution of the DWD Data set. Analysis of this water quality data showed that approximately 30% of all Borehole and Shallow well water sources have a pH less than 6.5.

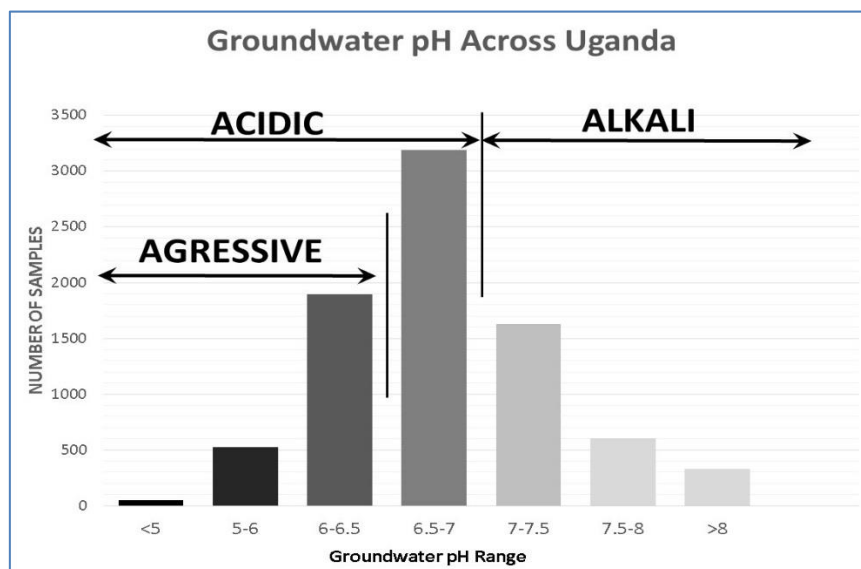

Figure 3. Distribution of Groundwater samples by pH Range

SUSTAINABLE GROUNDWATER DEVELOPMENT

Pump Technologies – Solar and Hand-powered

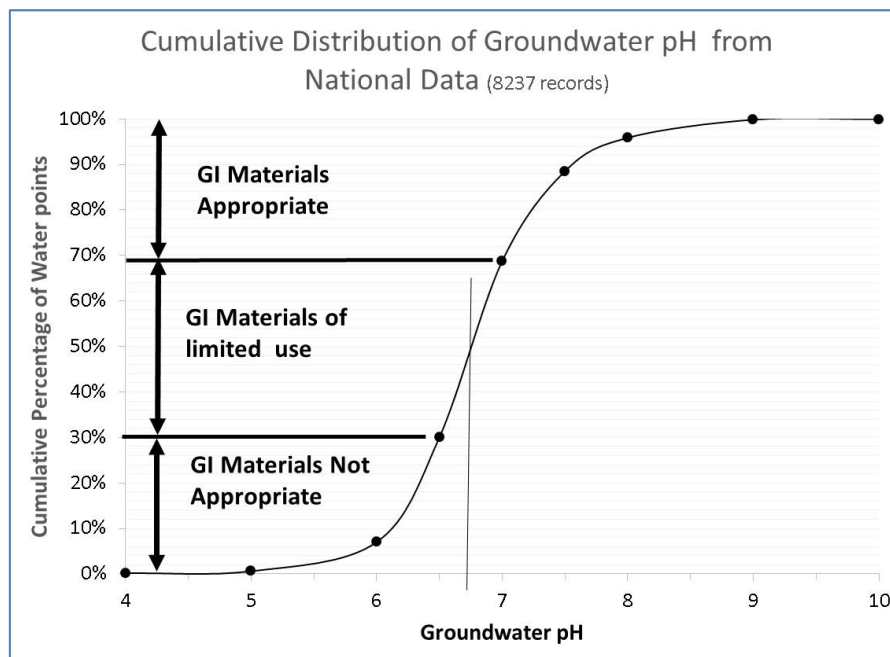

Figure 4. Cumulative distribution by Water point pH

Given that there are almost 25,000 handpumps in Uganda, this implies that some 7,500 hand pumps are installed into aggressive ground water; GOAL staff have seen high-levels of compliance with the national U2 (India Mark II) around the country and this implies that the vast majority of these pumps will be using unsuitable GI pipe and risers.

Some stakeholders have cast doubt on the reliability of the water quality records that are logged with new boreholes<sup>49</sup>. This stems largely from the fact that it is generally the responsibility of the driller to collect and deliver samples to the government laboratories. As there is no control over the process there would seem to be significant opportunity for standard procedures to be ignored. In order to test this hypothesis, GOAL performed an independent analysis of the 44 boreholes reviewed earlier. The results shown in figure 5 below show a very close correlation to the original data submitted with the borehole logs from 3 different contractors. Clearly this is a tiny sample and other drillers may (or may not) follow their own procedures which could result in erroneous data, however this result does offer some confidence that not all of the data can be discounted.

<sup>49</sup> V Casey et al, 2016; The role of handpump corrosion in the contamination and failure of rural water supplies

## SUSTAINABLE GROUNDWATER DEVELOPMENT

### Pump Technologies – Solar and Hand-powered

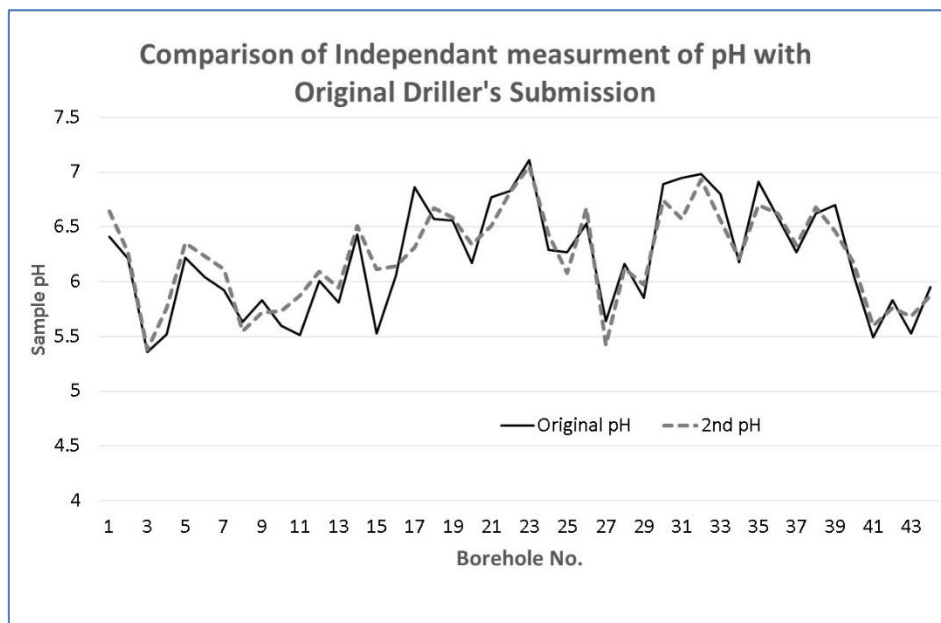

Figure 5. Independent Verification of the Original Water Quality Data Submitted by Drillers

### Conclusions

Given the evidence and recommendations from Langenegger and the RUWASA Project together with more recent in country research (V.Casey et Al, 2016; WE Consult, 2016), then this data clearly shows that there is a significant issue in Uganda with regards to risk of corrosion that the current handpump standards fail to address adequately.

The original intention of introducing the Handpump Standardisation strategy would appear to have been a sound approach that achieved its objective. However, the standard developed for Uganda is not appropriate for the India Mk II hand pump in all areas. As a result there is likely to be an increased financial burden being placed on the 30% of rural communities that are unfortunate enough to rely low pH ground water for their domestic needs. In turn this will contribute to lower functionality levels across the country given the general lack of capacity of the community to deal with repeated corrosion based repairs.

This is exactly the issue the J. MacArthur was referring to in the conclusions to her paper when she says: *“Some formal standardisations need a facelift. While many formal policies started out with good intentions, a lot has changed since the 1990s and some policies need to be revised due to improper selections or limitations on the incorporation of improved technologies. This is a lengthy and costly process, which requires the collaboration of many handpump stakeholders on both the local and global levels. Additionally, while standardisation is controlling the installations across the continent, the topic has lost momentum in the global sustainability dialogue.”*

Clearly switching to non-corrosive materials is not a simple exercise as there are several factors that need to be considered. Firstly there is the issue of supply chains – or lack thereof – that will need to be established. Secondly there is the issue of training technicians to become familiar with the different materials and thirdly there is the extra funding that will be needed to pay for the corrosion resistant materials – especially stainless steel.

Whilst this discussion has focused on the situation in Uganda, the problem is certainly not isolated. Given that many of the standards that are still in place across the continent were written more than 25 years ago and how our knowledge and available technology has developed in that same period it is highly likely that the existing standards are no longer the most appropriate. However, having struggled to get standards in place, many governments seem to be happy to continue using them even when there may be clear need to update or adapt them to better suit the situation on the ground. In part this seems to be caused by

## SUSTAINABLE GROUNDWATER DEVELOPMENT

### Pump Technologies – Solar and Hand-powered

aspirations to provide a higher level of service altogether (small piped networks) which are becoming more viable as technology improves. Welcome though a higher service level maybe, it is unlikely to effect the majority of the existing handpump users for decades to come.

The India MkII is the most commonly used hand pump across sub-Saharan Africa<sup>5</sup>, currently used in 25 countries out of the 35 that use handpumps. There are potentially lessons to be shared and learnt from other country’s experiences. In Uganda the India Mk II (U2) has far wider use than the U3 and U3M. In part this is down to a lack of familiarity with these pumps among the sector actors and mechanics, but also it is only suitable for depths of up to 45 m which is insufficient for many locations. Furthermore as the U3M uses large diameter PVC pipe, which is not currently widely available and quality is a constant issue leading to frequent breakages – further weakening its image in the sector.

### Recommendations

1. At the national level, raise the issue of handpump corrosion and the inadequacy of the current standards for the prevailing groundwater conditions with the government and partners.
2. In the short term a relatively simple step would be to raise the limit at which pH triggers the use of corrosion resistant materials – from 5.5 to a minimum of 6.5 and preferably 7.0.
3. Work together with the government and sector partners to establish more appropriate hand-pump standardisation strategy (is the India MkII still the most appropriate pump for Uganda?).
4. Agree interim and longer term plans to address the issue of pump corrosion – firstly for new boreholes, and then for the replacement or upgrade of corroded pumps.
5. Use the complete water quality database (each borehole has water quality test conducted that is logged with the Ministry of Water and the Environment) to produce a complete Groundwater pH map that could be used to raise awareness of potential hotspot areas and the corrosion issue in general.
6. Verify the validity of the above pH analysis and data by independent pH measurement on a significant number of data points.

SUSTAINABLE GROUNDWATER DEVELOPMENT

Pump Technologies – Solar and Hand-powered

# Preliminary results from an evaluation of the Blue Pump in Turkana, Kenya

Type: Short Paper

**Authors:** Tim Foster<sup>a</sup>, Brian McSorley, Juliet Willetts

<sup>a</sup>Chancellor’s Postdoctoral Research Fellow

Institute for Sustainable Futures, University of Technology Sydney, Australia

Email: tim.foster@uts.edu.au, Tel: +61413231799

## Abstract/Summary

This paper presents the preliminary results of an evaluation of the Blue Pump in Turkana County, Kenya. Field work was carried out at 142 waterpoints to comparatively assess the operational performance and water user experiences for the Blue Pump. In order to appraise the broader factors affecting the suitability and sustainability of the Blue Pump, a group of key stakeholders was also convened to apply the Technology Applicability Framework. While 1 in 3 Blue Pumps in Turkana was found to be non-functional, breakdowns were less frequent than for the India Mark II and Afridev. Users of the Blue Pump were more satisfied with the reliability of their water service than those using other handpump types, but the difficulty of operation was a prominent complaint. In the Turkana context, the Blue Pump appears to be a more reliable handpump than the India Mark II and Afridev, bearing in mind its higher upfront cost. However, its full value will only be realised if coupled with effective and sustainable maintenance arrangements for which users are willing and able to pay.

## Introduction

The Blue Pump is a lever-action reciprocating handpump which is promoted as a more durable alternative to mainstream handpump models. Developed by Fairwater Foundation, the pump has been deployed in numerous countries throughout sub-Saharan Africa.<sup>50</sup> According to the developer, the pump is a low maintenance technology with a number of comparative advantages, including lower recurrent costs, ease of installation, and greater depth range (Van Beers, 2013a, 2013b). The pump has an open top cylinder design which allows for the rods and the cylinder to be removed without the need to pull up the riser pipes, while a bottom support system enables cylinder depths up to 80 meters.<sup>51</sup> Other design features include the lack of a rubber seal in the piston, PVC pipes, heavy duty bearings, and compatibility with the pedestal of an old India Mark II or Afridev.

In order to appraise the suitability of the Blue Pump as a rural water supply technology, in February 2016 Oxfam Kenya commissioned an evaluation of Blue Pump installations in Turkana County. Although previous studies have investigated the early stages of the Blue Pump roll-out in Turkana (McSorley, 2011) and 14 installations in Mozambique (Cornet, 2012), there have been calls for further empirical evidence that sheds light on the performance of the Blue Pump relative to other handpump technologies. This paucity of information is not unique to the Blue Pump – despite the enduring dominance of handpump water supplies in rural areas, there have been surprisingly few field evaluations of different technologies in the last two decades. Since the large-scale testing carried out under the auspices of the World Bank in the 1980s (see e.g. Reynolds, 1992), only a handful of investigations have attempted to conduct field-based comparisons of performance (Harvey & Drouin, 2006; Coloru et al., 2012, Nampusuor & Mathisen, 2000). Analyses of waterpoint mapping datasets have begun to illuminate functionality rates for different

<sup>50</sup> See <http://www.fairwater.org/sponsor-a-bluepump/>

<sup>51</sup> In some circumstances in Turkana, pump cylinders have been installed at depths of up to 90m.

## SUSTAINABLE GROUNDWATER DEVELOPMENT

### Pump Technologies – Solar and Hand-powered

handpump types (Foster, 2013; Fisher et al., 2015), although the limitations of this binary metric are well documented (Carter & Ross, 2016).

Since 2007, Oxfam Kenya and its partners have overseen the installation of more than 100 Blue Pumps in Turkana County in the north of Kenya. Turkana provides a particularly challenging environment for handpumps. The region is characterised by low levels of rainfall (typically <400mm per year) and there is a heavy dependence on handpumps both for domestic purposes and for watering livestock. Handpump usage levels can be extreme, with many used non-stop throughout daylight hours and often late into the evening. Moreover, pump cylinders often need to be positioned at great depths (e.g. up to 90m) owing to the deep groundwater levels in certain areas. There are two further distinguishing features of the rural water landscape in Turkana. First, in addition to the Blue Pump, the county plays host to Afridev, India Mark II and Duba Tropic 2 handpumps in roughly equal numbers (RVWSB, 2013). Second, maintenance service provision for handpumps of all kinds is by way of a centralised scheme operated by the Diocese of Lodwar. As such, very few repairs (if any) are carried out by communities or local area mechanics.



Figure 1 – Blue Pump installation in Northern Turkana

Table 1 – Technical and supply chain details of handpumps in Turkana County

	Blue Pump	Afridev	India Mark II	Duba Tropic 2
<b>Technical details</b>				
Operation	Lever	Lever	Lever	Rotary
Depth	<80m	<45m	<80m	<100m
Open-top cylinder	Yes	Yes	No	Yes
Rising main	PVC	PVC	GI	GI
Domain	Private	Public	Public	Private
<b>Supply chain details</b>				
Location of manufacturer	Netherlands	India	India	Belgium
Location of suppliers	Nairobi	Lodwar, Nairobi	Lodwar, Nairobi	Belgium

## SUSTAINABLE GROUNDWATER DEVELOPMENT

### Pump Technologies – Solar and Hand-powered

Buyers	Oxfam, Practical Action	County Government, Diocese of Lodwar	County Government, Diocese of Lodwar	Diocese of Lodwar <sup>52</sup>
--------	-------------------------	--------------------------------------	--------------------------------------	---------------------------------

### Description of the Case Study – Approach or technology

In order to evaluate the performance of the Blue Pump in Turkana, the evaluation consisted of two components:

1. Site visits at Blue Pump installations to understand operational performance, life-cycle costs, and water user experiences. Given the challenging conditions of Turkana it was decided to also include site visits at India Mark II, Afridev and Duba installations to allow for a comparative assessment. For these “comparator” pumps a convenience-quota sampling method was preferred over a randomized sampling approach due to incomplete information about handpump locations and the vast size of the county.
2. A Technology Applicability Framework (TAF) workshop was conducted to appraise the broader building blocks for sustainability of Blue Pump installations. This involved stakeholders from local government, maintenance service providers, and implementing organisations. The workshop followed the methodology outlined in Olschewski & Casey (2015).

In total, 100 Blue Pump installations were identified from records kept by Oxfam and Practical Action.<sup>53</sup> Of these, 25 could not be accessed as they were situated in insecure regions. Seventy-five sites were subsequently visited, with 71 Blue Pumps installations confirmed.<sup>54</sup> Data were also collected for 71 comparator handpumps, comprised of 34 India Mark IIs, 24 Afridevs and 13 Duba Tropics. Characteristics of waterpoints visited are summarised in Table 2.

Table 2 – Mean characteristics of waterpoints visited in Turkana County

Characteristics	Blue Pump (n=71)	India Mark II (n=34)	Afridev (n=24)	Duba Tropic 2 (n=13)
Cylinder depth (m)	42	36	12	56
Age (years)	3.6	4.6	8.6	13.2
Distance to Lodwar (km)	86	81	97	92
Electrical conductivity ( $\mu\text{S}/\text{cm}$ ) <sup>a</sup>	1897	1629	922	1062
pH	7.61	7.50	7.52	7.39
Maintenance scheme subscription (%)	34	41	21	85

<sup>a</sup> Excludes two extreme outlier values.

Information at each waterpoint was collected on handpump performance and user satisfaction levels. Operational performance was measured across four indicators: (i) functionality rate, (ii) breakdowns in the previous 12 months, (iii) operational days in the previous 12 months, and (iv) flow rate when operated by an adult female. A handpump was deemed non-functional if it was not producing water for users on the day of inspection. Information relating to the number and duration of breakdowns was based on user recollections. Flow rate was measured by observing the number of seconds an adult female took to fill a 20 litre jerrican. In order to take into account other factors that can influence these performance metrics, data pertaining to cylinder depth, handpump age, usage levels<sup>55</sup> and maintenance arrangements were also sought. To ascertain water user views on the Blue Pump, a series of questions were asked about satisfaction levels with respect to reliability,<sup>56</sup> flow rate and ease of use. This paper presents the

<sup>52</sup> New Duba Tropic 2 pumps are no longer installed, although the Diocese of Lodwar continue to procure spare parts.

<sup>53</sup> This excludes a number of installations which were known to have been upgraded to solar pumps.

<sup>54</sup> One site could not be found and three Blue Pumps had been replaced – one by a solar pump, one by an India Mark II and one by an Afridev.

<sup>55</sup> As settlements in Turkana are often highly dispersed and migratory, estimating the number of households using the handpump was difficult. Moreover, the livestock population is likely to be a more significant driver of usage in many instances. Thus usage level was classified as either ‘non-stop during the day’ or ‘intermittent use’.

<sup>56</sup> In this context, reliability referred to how frequently (or infrequently) the system broke down.



## SUSTAINABLE GROUNDWATER DEVELOPMENT

### Pump Technologies – Solar and Hand-powered

preliminary results across each of these operational and satisfaction measures for the Blue Pump vis-à-vis the India Mark II and Afridev.<sup>57</sup>

#### Main results and lessons learnt

##### Operational performance

Based on the sample of handpumps assessed, overall the Blue Pump outperformed both the India Mark II and Afridev across measures of functionality, breakdowns per year and operational days per year (Table 3). This is tempered by the observation that one in three Blue Pumps was still found to be non-functional. On average, the Blue Pump broke down less frequently than other pumps across different cylinder depths, ages and usage levels (Table 4). Disaggregated differences in functionality rate and operational days were more mixed.

Table 3 – Summary of operational performance of sampled handpumps in Turkana County

	Blue Pump	India Mark II	Afridev
<b>All handpumps</b>			
Sample size	71	34	24
Functionality rate (%)	67.6	61.8	41.7
Avg. breakdowns per year <sup>a</sup>	0.4	0.8	1.3
Avg. operational days per year	284	255	167
Avg. flow rate for female adult (l/min)	11.3	13.1	14.6
<b>Handpumps 0-7 years</b>			
Sample size	66	28	10
Functionality rate (%)	68.2	60.7	20.0
Avg. breakdowns per year <sup>a</sup>	0.3	0.9	2.5
Avg. operational days per year	285	247	132
Avg. flow rate for female adult (l/min)	11.2	12.9	ND

ND = No data. <sup>a</sup> Calculated as weighted average of the number of breakdowns per operational year.

Table 4 – Operational performance of sampled handpumps in Turkana County disaggregated by key characteristics

	Characteristics	Categories	Blue Pump	India Mark II	Afridev
<b>Functionality rate (%)</b>	Cylinder depth	<20m	57.9	25.0	33.3
		20-40m	75.0	85.7	NS
		40+m	67.7	71.4	ND
	Age	0-3 years	75.0	60.0	20.0
		4-7 years	60.0	61.5	20.0
		8+ years	NS	66.7 <sup>a</sup>	63.6 <sup>a</sup>
	Maintenance scheme subscriber	Yes	76.2	83.3	75.0
No		65.0	52.9	40.0	
	<b>Functionality rate – All (%)<sup>b</sup></b>		<b>67.6</b>	<b>61.8</b>	<b>41.7</b>
<b>Avg. breakdowns per year</b>	Cylinder depth	<20m	0.2	NS	1.7
		20-40m	0.7	1.3	NS
		40+m	0.4	1.0	ND
	Age	0-3 years	0.4	0.8	3.4
		4-7 years	0.3	0.9	NS

<sup>57</sup> Full results and discussion (including results for the Duba Tropic 2) will be available in the final evaluation report.

## SUSTAINABLE GROUNDWATER DEVELOPMENT

### Pump Technologies – Solar and Hand-powered

	Characteristics	Categories	Blue Pump	India Mark II	Afridev
		8+ years	NS	NS	0.7
	Usage level	Intermittent	0.3	0.5	1.1
		Non-stop	0.5	0.9	5.5
	<b>Avg. breakdowns per year – All<sup>b</sup></b>		<b>0.4</b>	<b>0.8</b>	<b>1.3</b>
<b>Avg. operational days per year</b>	Cylinder depth	<20m	240	183	128
		20-40m	306	323	NS
		40+m	283	303	ND
	Age	0-3 years	318	232	192
		4-7 years	248	267	73
		8+ years	NS	NS	222
	Maintenance scheme subscriber	Yes	310	322	222
No		274	210	174	
	<b>Avg. operational days per year – All<sup>b</sup></b>		<b>285</b>	<b>255</b>	<b>167</b>
<b>Avg. flow rate for female adult (l/min)</b>	Cylinder depth	<20m	18.6	18.8	14.7
		20-40m	12.0	12.8	NS
		40+m	7.9	10.4	ND
	<b>Avg. flow rate for female adult – All<sup>b</sup></b>		<b>11.3</b>	<b>13.1</b>	<b>14.6</b>

NS = Not shown due to small sample size ( $n < 3$ ); ND = No data. Note: It was not always possible to ascertain cylinder depth and/or age for India Mark II and Afridev handpumps. <sup>a</sup> Further investigation is needed to determine why the older cohort of India Mark II and Afridev handpumps appear to have better functionality rates than the newer cohort. Possible explanations include a ‘denominator problem’ (see Carter & Ross, 2016) or confounding factors. <sup>b</sup> ‘All’ results include those handpumps with unknown cylinder depth and/or age.

It is instructive that the Blue Pump maintained an edge over the India Mark II for both operational days and functionality rate when handpumps were three years of age or less, but not for those pumps aged between 4 and 7 years. This may point to the limits of durability in the Turkana context – although first-time breakdowns may occur further down the track for the Blue Pump, sustainability in the long term will ultimately be defined by the presence or absence of effective maintenance systems.<sup>58</sup> Indeed, when subject to the same centralised maintenance service operated by the Diocese of Lodwar, the functionality rates for all three handpumps lay within a band of 75-85%. This compares to 40-65% for those waterpoints not registered for the maintenance scheme.<sup>59</sup> The functionality rate of the Afridev was particularly low for those communities not subscribing to the maintenance scheme. As well as more frequent mechanical breakdowns, this may in part be due to the susceptibility of shallow wells to dry up or silt up, and also their tendency to be located beside river beds, thereby offering alternative (unimproved) water sources.

Work is still underway to ascertain precise failure modes and root causes of Blue Pump breakdowns. Early estimates suggest 15-35% of failures may be attributable to factors other than mechanical faults (e.g. dry boreholes, wells silting up, flood damage). The most common mechanical failure modes appeared to relate to the cylinder (either leaking or clogged with silt), rod breakages and pipes. Work to determine the lifecycle costs of the Blue Pump is also ongoing. Data provided by the Diocese of Lodwar suggest an

<sup>58</sup> Another possible contributing factor is the evolution of the Blue Pump design, with component modifications potentially leading to a difference in operational performance between newer and older Blue Pump models.

<sup>59</sup> This maintenance model may obscure the potential benefits of reliability that might materialise in other contexts. Fewer breakdowns may not necessarily translate into higher functionality rates in Turkana because the Diocese of Lodwar provides communities with an unlimited number of repairs for a fixed annual tariff. In other words, the community pays the same fee irrespective of the number of breakdowns in a given year.

## SUSTAINABLE GROUNDWATER DEVELOPMENT

### Pump Technologies – Solar and Hand-powered

average Blue Pump repair costs \$68 in parts, compared with \$56 for an India Mark II and \$71 for an Afridev.<sup>60</sup>

On average, the discharge produced by the Blue Pump was 14% lower than for the India Mark II, a disadvantage which held across different cylinder depths. On the surface, this may seem a less important measure than other operational indicators assessed. However, one of the most prominent procurers of handpumps in Turkana chooses to install the India Mark II over the Blue Pump primarily because of the perceived difference in volumetric output.

#### Water user satisfaction

Water user perceptions largely accord with the findings on operational performance (Table 5). Overall, Blue Pump users were more satisfied with their water supply than users of other handpumps. This likely stemmed from the high reliability rating users attributed to the Blue Pump. Conversely, users preferred the alternatives when it came to flow rate and ease of operation. A widespread complaint among water users was that the Blue Pump is a ‘heavy’ pump that is significantly more difficult to operate, particularly once the cylinder depth exceeds 40 metres. In some instances, this precluded use by young children, and for deeper boreholes required 3 to 4 women to operate the pump simultaneously. When users directly compared the Blue Pump with other pump types that had previously been installed on the same borehole or well, the Blue Pump was marginally favoured over both the Afridev and India Mark II.

*Table 5 - Percentage of interviewed water users satisfied with their handpump water supply*

	Blue Pump	India Mark II	Afridev
<b>All handpumps</b>			
Users satisfied with handpump overall	95%	85%	88%
Users satisfied with reliability	97%	74%	69%
Users satisfied with discharge	69%	73%	81%
Users satisfied with ease of operation	42%	56%	73%
<b>Handpumps 0-7 years</b>			
Users satisfied with handpump overall	94%	83%	88%
Users satisfied with reliability	96%	74%	50%
Users satisfied with discharge	71%	68%	88%
Users satisfied with ease of operation	41%	52%	75%

There are a number of caveats to the findings on operational performance and water user satisfaction. First, the sample sizes involved are relatively small, particularly when disaggregating results by various characteristics such as depth and age. Second, investigations into failure modes and lifecycle costs are still ongoing, limiting some of the inferences that can be made at this juncture. Third, information on breakdown frequency and duration was reliant on user recall. Fourth, these results apply to the Turkana context, which has some unique environmental, social and institutional characteristics.

#### Applying the Technology Applicability Framework

To assess the broader factors that impinge upon the suitability and sustainability of the Blue Pump in Turkana, stakeholders from local government, NGOs and service providers were convened at a workshop to apply the Technology Applicability Framework (TAF). The perspectives of users, service providers and investors were considered across six key sustainability dimensions (Figure 2).

<sup>60</sup> Assumes an exchange rate of 100 KES = 1 USD.

SUSTAINABLE GROUNDWATER DEVELOPMENT

Pump Technologies – Solar and Hand-powered

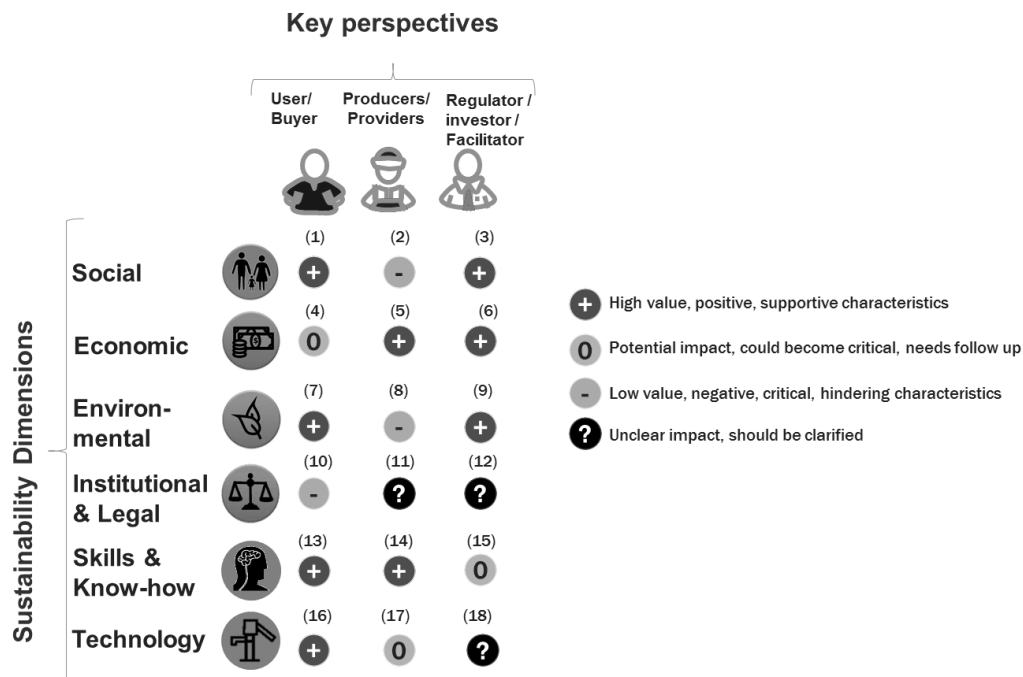

Figure 2 – TAF traffic light matrix for Blue Pumps in Turkana

Among the numerous issues debated, workshop participants identified several critical dimensions:

- **Social:** Overall, workshop participants believed there was demand from water users for the Blue Pump due to its durability. However, it should be noted that very few interviewed water users felt their community had a choice as to which technology was installed. From the buyers’ perspective, many participants agreed that the manufacturer and/or supplier needed to invest more in marketing and promotion at the local level so stakeholders knew how they could procure new pumps and access technical support. Although there is a Nairobi-based supplier (Techno Relief) who is able to deliver pumps to Lodwar and provide technical support, discussions revealed that two of the major handpump installers (County Government & Diocese of Lodwar) were unaware of this possibility.
- **Economic:** It was widely assumed that ongoing Blue Pump maintenance costs would require some form of subsidy in addition to user contributions. This was not necessarily seen as a problem as compared to other handpumps, as the centralised maintenance scheme operated by the Diocese of Lodwar has long offered a subsidised tariff (currently \$35 per waterpoint per year), irrespective of the handpump type. Water users generally view this as a fair and reasonable price, although in reality not all communities are willing and able to pay the annual subscription fee. Participants did, however, note capital costs as a disadvantage of the Blue Pump. Depending on the cylinder depth, a Blue Pump costs between \$1,500 and \$4,000, some two to three times more expensive than an India Mark II or Afridev for equivalent depths.
- **Skills and knowledge:** There was a consensus that the Blue Pump was not conducive to community-level maintenance arrangements in Turkana. Reliance instead is placed on the Diocese of Lodwar technicians, who have previously been trained on Blue Pump repairs and installation by Fairwater Foundation, and are now well versed on Blue Pump maintenance.
- **Technical:** Participants believed water users were satisfied with the Blue Pump, though were aware that many find the pump heavy and difficult to use. The question of whether a viable spare part supply chain exists generated substantial debate. Despite the existence of a Nairobi-based supplier who could deliver Blue Pump parts to Turkana, several attendees were of the view that in effect there was no viable supply chain because few were aware of this option. It is important to note that up until this point the supply chain issue has had little bearing on the sustainability of the Blue Pump. As the sole maintenance provider in Turkana, the Diocese of Lodwar continues

## SUSTAINABLE GROUNDWATER DEVELOPMENT

### Pump Technologies – Solar and Hand-powered

to draw on a large consignment of parts originally provided to them by Oxfam (in contrast, the Diocese of Lodwar purchases India Mark II and Afridev parts from Nairobi-based suppliers).

#### Conclusions and Recommendations

In the Turkana context, the Blue Pump appears to be a more reliable water supply technology than the India Mark II and Afridev. However, the pump is by no means maintenance free. A focus on reliability does not supplant the need for effective maintenance arrangements and other building blocks for sustainability. Given the uniqueness of the Turkana setting, further investigations are needed to verify whether the results hold up in other contexts. Aside from the social and hydrogeological characteristics of Turkana, the centralised maintenance model limits the degree to which these findings can be extrapolated to other rural areas where local area mechanics are the norm.

#### References

- Carter, R. & Ross, I. (2016) 'Beyond 'functionality' of handpump-supplied rural water services in developing countries', *Waterlines*, 35(1): 94-110.
- Coloru, B., Mgaya, S. & Taubert, R. (2012) 'Appropriate technologies for rural water supply', SHIPO & ACRA-CCS.
- Cornet, L. (2012) 'A Comparative Evaluation Of Ultra Deep-Well Handpumps', MSc Thesis, Cranfield University.
- Fisher, M. et al. (2015) 'Understanding handpump sustainability: Determinants of rural water source functionality in the Greater Afram Plains region of Ghana', *Water Resources Research*, 51 (10): 8431-8449.
- Foster, T. (2013) 'Predictors of sustainability for community-managed handpumps in Sub-Saharan Africa: Evidence from Liberia, Sierra Leone, and Uganda', *Environmental Science & Technology*, 47(21): 12037-12046.
- Harvey, P. & Drouin, T. (2006) 'The case for the rope-pump in Africa: A comparative performance analysis', *Journal of Water & Health*, 4: 499-510.
- Nampusuor, R. & Mathisen, S. (2000). 'Report on The Performance of Afridev and Nira Handpumps on the Upper Regions Community Water Project (COWAP) Ghana', COWAP Field Paper 27.
- Olschewski, A. & Casey, V. (2015) 'The Technology Applicability Framework. A Participatory Tool to Validate Water, Sanitation, and Hygiene Technologies for Low-Income Urban Areas', In Hostettler et al. (eds) *Technologies for Development* Springer International.
- Reynolds, J. (1992) 'Handpumps: Towards a Sustainable Technology', UNDP-World Bank Water and Sanitation Program, Washington DC.
- RVWSB (2013) 'Water Point Mapping Report, Turkana County', Rift Valley Water Services Board, Nakuru.
- Van Beers, P. (2013a) 'The FairWater Blue Pump', Fairwater, Amsterdam.
- Van Beers, P. (2013b) 'Summary Graphic: Bluepump vs Public Domain Pump', Fairwater, Amsterdam.

#### Acknowledgements

The authors would like to thank and acknowledge the role of Oxfam in supporting the evaluation – in particular, Sepharinus Owino, Nicholas Sikenyi, Mark Nakalale and Robert Samal – as well as all stakeholders and water users who participated in the assessment. The authors also owe a debt of gratitude to members of the evaluation advisory group (Sean Furey, Peter Harvey, Richard Carter and Rob Hope) and to André Olschewski for his guidance on the Technology Applicability Framework.

SUSTAINABLE GROUNDWATER DEVELOPMENT

Pump Technologies – Solar and Hand-powered

---

## Poste d'Eau Autonome Solaire versus Pompe à Motricité Humaine

### Un pas décisif vers le robinet à la maison ?

---

Type: Article court

Auteurs: Jacques Louvat conseiller régional HELVETAS Swiss Intercooperation Afrique de l'Ouest  
Contact: [jacques.louvat@helvetas.org](mailto:jacques.louvat@helvetas.org) / +223 77 28 73 48

#### Résumé

Au Sahel, malgré plusieurs décennies d'accompagnement, 1 pompe manuelle sur 3 n'est pas fonctionnelle<sup>61</sup> et le renouvellement des équipements nécessite un financement extérieur. Les usagers n'ont pas d'argent pour réparer leur pompe mais ils en ont pour utiliser leur téléphone portable. Néanmoins, lorsque la qualité du service est suffisamment élevée (robinet à domicile), l'utilisateur accepte de payer régulièrement. Plutôt que de promouvoir les pompes manuelles, HELVETAS Mali encourage la réalisation de micro réseaux solaire avec des robinets à proximité de l'utilisateur. Les choix technologiques retenus (pompage sans batterie, réservoir en ferrociment fabriqué localement) sont simples et économiques. Les usagers peuvent facilement étendre le réseau et disposer d'un robinet chez eux. La qualité de l'eau est nettement améliorée. Concernant la gestion, HELVETAS accompagne les usagers mais leur laisse la latitude de s'organiser comme ils l'entendent : à l'instar de l'utilisation du téléphone, le villageois a plus besoin d'information que de conseil.

#### Introduction

Dans les pays en voie de développement, la pompe à motricité humaine (PMH) constitue généralement l'équipement de base pour accéder à l'eau potable. Mais dans la majorité des cas, les usagers éprouvent de grandes difficultés pour s'en approprier la gestion. Souvent, lorsque la pompe tombe en panne, les villageois préfèrent retourner à des points d'eau de qualité douteuse (puits traditionnels, mare, rivière...) plutôt que de payer pour la réparation.

Sur les sites où il n'existe pas d'autre source d'eau alternative, la pompe est généralement rapidement réparée, mais lorsque les pannes deviennent répétitives et qu'il faut la remplacer, il est rare que les populations y parviennent et l'accès à l'eau potable devient alors particulièrement difficile.

Parallèlement, dans un tout autre domaine, on constate l'explosion du téléphone portable, y compris dans les zones défavorisées : aucune formation n'est dispensée à des utilisateurs qui le plus souvent ne savent ni lire ni écrire, pourtant cela ne leur pose pas de problème majeur pour manipuler leur téléphone ! Pas de subvention non plus pour acheter le portable ou les unités, mais les ménages réussissent néanmoins à acquérir un appareil, à recharger leur compte et à téléphoner.

Vu de l'extérieur, le manque d'argent pour réparer la pompe semble plus lié au niveau de priorité que l'on accorde à l'eau potable qu'à un réel blocage financier.

Depuis des décennies les projets de développement essaient d'organiser les populations rurales pour qu'elles s'approprient et gèrent leur point d'eau. Mais peut-être ont-ils négligé l'étape initiale ? Il semble qu'il faudrait au préalable susciter chez les futurs usagers, une réelle envie de consommer de l'eau saine. Une fois ce besoin solidement ancré, les populations seront plus réceptives pour adopter un comportement qui leur permettra de bénéficier de ce service de façon durable, et en particulier de payer !

---

<sup>61</sup> RWSN (2009) Handpump Data 2009. Selected Countries in Sub-Saharan Africa, RWSN, St Gallen, Switzerland

## SUSTAINABLE GROUNDWATER DEVELOPMENT

### Pump Technologies – Solar and Hand-powered

#### Contexte, objectifs et activités

Pour donner aux populations l'envie de consommer une eau saine, HELVETAS Swiss Intercooperation mise sur l'amélioration de la qualité du service : on constate en effet sur le terrain que les ménages qui disposent d'un robinet à la maison n'acceptent plus de retourner chercher l'eau à la pompe. Ils ont compris et ils vivent les avantages d'un service de qualité et ils sont prêts à payer pour le conserver.

**La qualité du service incite les usagers à payer.** Dans le petit village de Koin (commune de Bladiè, Sud Mali) la population a très rapidement mobilisé 3.000 euros pour réparer le mini réseau d'adduction alors qu'au même moment, dans les villages environnants plusieurs pompes à motricité humaine en panne étaient abandonnées par les utilisateurs.

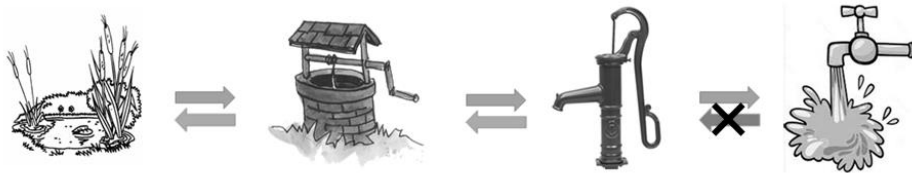

Payer pour le service de l'eau n'est pas naturel ! Pour que de nouvelles habitudes se mettent en place, il faut impérativement un système moins pénible et surtout fiable !

Au Sahel il existe 3 grandes familles d'équipements pour l'hydraulique villageoise qui correspondent à trois niveaux de service bien distincts:

- Les puits où le puisage est fait de façon manuelle
- Les pompes à motricité humaine (PMH) installées le plus souvent sur des forages. Le pompage est également manuel mais moins pénible que pour le puits
- Les bornes fontaines ou branchement particuliers reliés à un mini réseau d'adduction gravitaire, alimenté par une pompe électrique. L'effort de puisage est supprimé.

Au regard des prix généralement pratiqués pour les équipements hydrauliques classiques, un problème se pose : comment alimenter à moindre coût un village de 2-3000 habitants, trop gros pour des PMH et trop petit pour un mini réseau?

Au Sahel, toutes les stratégies nationales prévoient, un ouvrage intermédiaire, une sorte de mini réseau, privé de canalisation de distribution. Au Mali, c'est le Système d'Hydraulique Villageoise Amélioré (SHVA) aussi appelé poste d'eau autonome (PEA). Il s'agit d'une infrastructure d'eau potable capable de fournir de 10 à 30 m<sup>3</sup> d'eau par jour. Il comprend un réservoir au sol ou surélevé alimentant une rampe de robinets ou une borne fontaine. Le plus souvent, la source d'énergie est un groupe électrogène, ce qui occasionne des problèmes récurrents de maintenance et de renouvellement. De plus, son prix est élevé et il constitue une source non négligeable de pollution.

On retrouve le PEA au Burkina Faso, mais il reste un ouvrage relativement cher, essentiellement réalisé dans la périphérie de gros centres urbains.

## SUSTAINABLE GROUNDWATER DEVELOPMENT

### Pump Technologies – Solar and Hand-powered



*Poste d'eau autonome à la périphérie de Ouabigonya (Burkina Faso).  
Coût : environ 15 millions F CFA sans le forage.*

### Résultats principaux et leçons tirées

En se basant sur tous ces constats, HELVETAS Swiss Intercooperation propose d'innover tout en mettant l'accent sur trois aspects particuliers :

- la qualité du service afin que les usagers accordent un caractère prioritaire à une eau de boisson saine, accessible de façon durable,
- l'alimentation des gros villages à un prix abordable, pour offrir une solution technologique adaptée et surtout évolutive,
- La promotion des énergies renouvelables.

Pour mettre fin aux réhabilitations récurrentes des pompes à motricité humaine, HELVETAS préfère remplacer les PMH par des pompes solaires : pour un coût un peu supérieur, l'utilisateur n'est plus obligé de pomper. Pour pallier à la question de la distance au point d'eau et du transport, une solution consiste à réaliser un réservoir qui sera le point de départ d'un futur micro réseau d'adduction avec des points de desserte à proximité (voire à l'intérieur) des habitations.





## SUSTAINABLE GROUNDWATER DEVELOPMENT

### Pump Technologies – Solar and Hand-powered

*Poste d'eau autonome solaire réalisé par HELVETAS à Faradiélé (Mali). Coût :  
environ 7 millions F CFA sans le forage.*

Les PEA réalisés par HELVETAS au Mali ont un réservoir en ferrociment d'une capacité d'environ 20 m<sup>3</sup>, posé à même le sol. Il est construit par des maçons de la région, avec des matériels et matériaux disponibles localement. La base et le toit du réservoir sont en béton armé tandis que les parois sont constituées de mortier<sup>62</sup> ferrillé. La construction coûte environ 1 500 euros, beaucoup moins cher à volume égal, qu'un réservoir en plastique ou en métal.

Le système d'exhaure est constitué d'une pompe immergée fonctionnant au fil du soleil (sans batterie) alimentée simplement par un champ de panneaux solaires. Ce matériel de pompage et les compétences nécessaires à son installation, sont disponibles dans toutes les capitales ouest africaines. Dans des conditions normales d'utilisation, ces équipements fonctionnent sans aucune intervention pendant au minimum 5 ans, mais parfois 8 voire plus de 10 ans.

S'il n'y a au début qu'une borne fontaine à proximité du réservoir, il est possible ensuite de tirer des canalisations pour installer d'autres robinets à proximité, voire à l'intérieur, des habitations. Mais étant donné que l'écoulement de l'eau est gravitaire, il est important de chercher à installer le réservoir sur un point naturellement haut.

Avant de commencer les travaux, il est fondamental de réaliser un essai de pompage sur l'ouvrage concerné afin de vérifier que son potentiel hydraulique est compatible avec les besoins. Un débit minimum de 10 m<sup>3</sup>/jour est nécessaire pour assurer le fonctionnement de l'ouvrage. Mais il est tout à fait envisageable, dans le cas par exemple d'une extension du réseau, de raccorder ultérieurement un autre point d'eau au réservoir.

Il faut également faire une analyse de l'eau, un nettoyage de l'ouvrage, et une désinfection de l'eau, une fois les équipements installés.

#### Les éléments constitutifs de base du PEA solaire sont :

- Le forage avec un débit minimum de 10 - 15 m<sup>3</sup> / jour et une eau conforme aux normes de qualité.
- La pompe immergée fonctionnant au fil du soleil (pas de stockage de l'énergie).
- Les modules photovoltaïques et un coffret électrique.
- Le réservoir en ferrociment d'une capacité de 20 à 50 m<sup>3</sup>.
- La borne fontaine.

**Attention !** Compte tenu de la faible pression dans les tuyaux (le réservoir n'est pas surélevé) il est fondamental d'utiliser une tuyauterie de gros diamètre (Ø 40 mm) à la sortie du réservoir afin de permettre un bon écoulement de l'eau.

#### L'évolution du PEA solaire

A partir du micro réseau de base constituant le PEA solaire, il est possible de rajouter des tuyaux pour installer des bornes fontaines et/ou des branchements particuliers dans des zones situées en aval du réservoir. Ce type d'extension permet d'alimenter un quartier, voire un village tout entier si le point d'eau est suffisamment productif.

En fonction de l'évolution de la consommation, on pourra raccorder un autre point d'eau au réservoir, ce qui va accroître d'autant les possibilités de distribution du système.

#### Et la gestion ?

Les systèmes fonctionnant à l'énergie solaire sont connus pour ne pas encourager les usagers à payer l'eau : étant donné que tout fonctionne sans qu'il soit nécessaire d'acheter du carburant ni de faire des vidanges,

<sup>62</sup> Le mortier est constitué d'un mélange de sable, de ciment et d'eau. Pour obtenir du béton, on rajoute du gravier

## SUSTAINABLE GROUNDWATER DEVELOPMENT

### Pump Technologies – Solar and Hand-powered

les populations oublient souvent que lorsque la pompe s'arrête il faut d'un seul coup mobiliser de fortes sommes d'argent pour réparer.

Aussi, plutôt que de créer des comités de gestion où des structures de cet acabit qui ne correspondent quasiment jamais à un mode d'organisation local et qui d'ailleurs ont montré leurs limites, HELVETAS préfère, dans le respect des stratégies nationales, accompagner les usagers pour les laisser choisir un mode d'organisation qui leur convient. Des visites sont organisées sur d'anciennes adduction d'eau fonctionnelles ou non (thermiques, solaires,), des discussions ont lieu avec les usagers, des contacts sont pris avec des fournisseurs de matériels solaires, les prix et modalités sont connus, des devis sont disponibles, des réunions sont animées, des réflexions lancées...

Mais surtout, quel que soit le mode de gestion retenu, des extensions du réseau et des branchements privés sont fortement encouragés.

En 2014 et 2015, HELVETAS a construit cinq PEA Solaire dans le Cercle de Bougouni au Mali. Depuis, de nombreuses initiatives prises de façon autonome par les acteurs démontrent que les usagers considèrent le service de l'eau comme une priorité et qu'ils ont la volonté de payer pour le préserver.

- A Faradiélé, les populations se sont organisées en Association des Usagers de l'Eau (AUE) et un système de paiement s'est mis en place. Le compte bancaire est régulièrement alimenté et des compétences locales (plombier, maçon) sont sollicitées pour la maintenance du système.
- A Bladié et Massakorobougou les usagers ont financé sur fonds propres des extensions pour améliorer la desserte dans le village. Coûts de l'opération, respectivement 1.200 et 1.400 euros.
- A Massakorobougou la caisse eau est alimentée par des ressources liées à des activités agricoles et communautaires : coopérative, champs collectifs, prestations des associations des jeunes et des femmes. Ce sont ces fonds qui ont permis de réaliser l'extension (2 bornes fontaines et 450 mètres de tuyauterie).
- A Yiridougou, les usagers ont financé des clôtures grillagées pour protéger les bornes fontaine, un compteur pour mieux gérer la distribution. Coût global 400 euros. Elles ont également mis en place un fontainier.

Plusieurs cas de business local liés au service de l'eau sont également à mentionner, comme ce jeune entrepreneur installé à Yiridougou qui a investi 450 euros pour aménager une station de lavage de motos.

**Leçon apprise :** Dans tous les villages du Sud Mali il existe des associations villageoises (coopérative, femmes, jeunes...) qui sont souvent très dynamiques. Plutôt que d'encourager des cotisations à l'échelle ménage, il semble plus efficace de laisser une association villageoise existante gérer la collecte des fonds alloués au service de l'eau. Le respect des échéances et également la prise en compte des indigents (qui sont dispensés du paiement) sont beaucoup plus efficace. Cette disposition évite de bloquer des fonds uniquement pour l'eau, encourage la solidarité et constitue surtout une garantie que de l'argent sera disponible.

### Les prochaines étapes

Beaucoup reste à faire pour atteindre un fonctionnement durable des PEA solaires et l'équipe d'HELVETAS Swiss Intercooperation Mali est consciente des enjeux. Plusieurs actions, dont certaines menées en continu, sont actuellement mises en œuvre :

- La facilitation des branchements privés au niveau des PEA solaires existant et l'encouragement de l'auto approvisionnement des villages environnants.
- L'accompagnement des initiatives de gestion tout en prenant soin de n'être jamais directif
- La communication et le partage sur les pratiques de gestion mises en œuvre dans les PEA solaire existants, y compris des visites d'études et des réunions d'échanges.
- Une expérimentation de réservoirs surélevés (actuellement en cours).

## **SUSTAINABLE GROUNDWATER DEVELOPMENT**

### **Pump Technologies – Solar and Hand-powered**

- Un plaidoyer à l'échelle du ministère pour valider officiellement la technologie du PEA solaire.

Toutes ces mesures d'accompagnement se font dans un esprit de partage et d'apprentissage. L'objectif n'est pas d'uniformiser les approches mais au contraire d'encourager toutes les initiatives qui concourent à la durabilité du service.

### **Conclusions et recommandations**

HELVETAS Swiss Intercooperation a fait le choix de responsabiliser les populations et de leur faire confiance pour gérer leur système d'adduction d'eau et son évolution future. A l'instar de l'utilisation du téléphone, le villageois a plus besoin d'information que de conseil. Lorsque l'eau du robinet ne coulera plus, il ne retournera pas à la pompe mais se manifestera et agira pour conserver la qualité du service qu'il a réussi à obtenir.

## SUSTAINABLE GROUNDWATER DEVELOPMENT

### Pump Technologies – Solar and Hand-powered

# Replacing Type “B” Bush Pumps With Solar Powered Pumps For Rural Water Supply

#### Type: Long Paper

Authors: Annie R. Mudzingwa, Graduate Engineer, Hazen Engineering, Zimbabwe, [annie@hazenengineering.com](mailto:annie@hazenengineering.com), +263-773 077 316

Berverly F. Nyakutsikwa

Kudakwashe C. Ngogodo

#### Abstract/Summary

For close to a century now, Zimbabwe's rural areas have been served by the type B bush pumps and it is time that we consider changing to a technology that eases amount of work put into fetching water as well as facilitates the further development of rural communities like solar (PV) powered water pumps. The aim of this paper is to compare between the two pump technologies to justify the decision to replace type B bush pumps with PV water pumps. The summarised benefits of PV systems are low labour requirement, low operation and maintenance costs, universal access to water, improved productivity, improved access to education for girls and improved health. Though the initial costs can be high, they can be implemented for their return on investment in the long term in addition to their benefits earlier mentioned. It should be noted that optimum performance of PV systems is dependent on geographic and climatic conditions and so may be unsuitable for some areas.

#### Introduction

Just like in any other developing country, Zimbabwe has isolated rural areas which pose challenges to rural energy management and development due to poor road links to urban centres and remoteness from the national electricity grid. Thus the potential of the use of renewable energy becomes great in such areas. According to (Baumann et al., 2010), the climate in many developing countries is suitable for solar energy pumping making solar energy a valid option for small scale water pumping schemes. The applications of solar energy are growing at a steady rate all over the world. With an average radiation of 2 100kWh/m<sup>2</sup> and 3 000 hours of sunshine per year (ZERA, 2015), Zimbabwe is deemed to have sufficient potential for solar energy and has already begun embracing this technology for water pumping. There are two solar powered water pumping systems in Bulilima district implemented by Troicare International (Sibanda, 2015), solar powered drip irrigation systems in Gwanda North implemented by Practical Action (Gono, 2016), a gravity fed irrigation system with solar powered water pumping system in Gutu and a solar-powered water pump for water supply at Mazuru Clinic, Gutu, implemented by Oxfam and Practical Action (Magrath, 2015), just to name a few.

Over the years, the communal areas of Zimbabwe have been largely served by a home-grown solution for water pumping, the bush pump for close to a century now. First designed in 1933 by Tommy Murgatroyd, a water officer in Matebeleland, the bush pump underwent many refinements to make it more user-friendly and durable. The result was the type “B” bush pump which was adopted as the national standard model in 1989. As of 2011, over 40 000 type “B” bush pumps (Morgan, 2011) had been set up. Optimum performance of this unit can only be expected if the components are correctly manufactured and also correctly installed. Over the years, the service by these pumps has been characterized by high labour requirements, long walking distances to fetch water and frequent breakdowns. It is important to note however, that even with many replacements of pipes and fittings, some bush pumps installed in 1930s are still working. Therefore, the choice of replacing bush pumps with solar powered water pumps is a matter of the performance and benefits of the “B” type bush pump as compared to the latter.

#### Context, aims and activities undertaken

## SUSTAINABLE GROUNDWATER DEVELOPMENT

### Pump Technologies – Solar and Hand-powered

The aim of this paper is to compare the advantages and disadvantages of the use of solar powered pumps against the use of Type “B” bush pumps for water supply in rural areas in order to justify the decision of replacing Type “B” bush pumps with solar powered pumps. In order to achieve this, the authors consulted related literature and structured the information obtained as follows:

1. Background – this section covers the brief background of Type “B” Bush pumps and Solar powered pumps respectively.
2. Comparison between Type B bush pumps and solar powered pumps – this section covers the advantages and limitations of each technology in light of the other.
3. Conclusion – this section discusses the conclusion from the discussed issues.

### Background

#### Type “B” bush pump

The family of bush pumps is known to have served the rural communities of Zimbabwe for over 80 years now. First developed in 1933 by Tom Murgatroyd, a Water Supply officer (Morgan, 2011), there have been developments to this pump over the years. The pumps can be distinguished as type A and B. The type B was developed as further research was being done to ensure that the bush pump is more durable and user friendly. This development came about as an initiative by the National Action Committee (NAC) with combined efforts with District Development Fund, Ministry of Energy, Water Resources and Development and Ministry of Health and Child Welfare. The type B bush pump was adopted as the national handpump of choice in 1989 (Morgan, 2011). As of 2011, more than 40 000 type B bush pumps had been installed across Zimbabwe (Morgan, 2011).

The type B bush pump is categorised as a conventional lever action pump used to abstract water from a borehole. The type B bush pumps are usually fitted to communal boreholes or deep wells and are typically shared between 25 households, that is, about 250 users per pump. They can take water from depths ranging from 18 to 100m and the typical yield range ranges from 3l/min in the drier areas where the borehole depth might be 100m to 15l/min in wetter areas with shallow ground water (Guzha et al., 2007). An illustration of the type B bush pump is shown in Figure 1.

Morgan (2011) describes the “B” type bush pump as follows: The wooden block, which is made of teak, is attached to the pump stand and rotates around a large bolt called a pivot pin. The rods which connect to the piston within the cylinder below move up and down within a “string” of steel pipes (known as the “rising main”). The uppermost rod passes through a floating washer housing, where a set of 2 moving washers accommodate for the horizontal movements of the rod within the pipe. The uppermost rod is connected to the pump head through a “U bracket.” The U bracket is attached to another pivot pin which passes through a forward hole in the wooden block. The wooden block has 2 sets of holes, a method derived from earlier Bush Pumps. When the first set of holes wears out, the second set can be put into use. The wooden bearing has a very long life. The “B” type pump head is used with standard “down-the-hole” components, comprising 50mm nominal bore galvanised steel rising main, 16mm mild steel pump rods, a 75mm diameter brass cylinder operating with a piston fitted with two leather seals and a heavy duty brass foot valve. These components are well tested and durable if correctly made and installed.

As de Laet & Mol (2000) quotes Morgan (1990): the Bush Pump operates on a lift pump principle, the reciprocating action being transferred from the pump head to the cylinder through a series of galvanised steel pump rods running inside a steel pipe (rising main). As far as maintenance is concerned, the basic requirement is keeping all bolts tight to ensure minimum wear of the working parts. Most of the maintenance that is required is linked to “down-the-hole” components. Seals on the piston need replacement from time to time. A rubber seal on a well-made heavy duty foot valve is made to last up to 10 years. Where the maintenance of down-the-hole components is concerned, it requires that the pipes are removed to inspect the parts underground. These pipes are heavy and require special lifting tools.

## SUSTAINABLE GROUNDWATER DEVELOPMENT

### Pump Technologies – Solar and Hand-powered

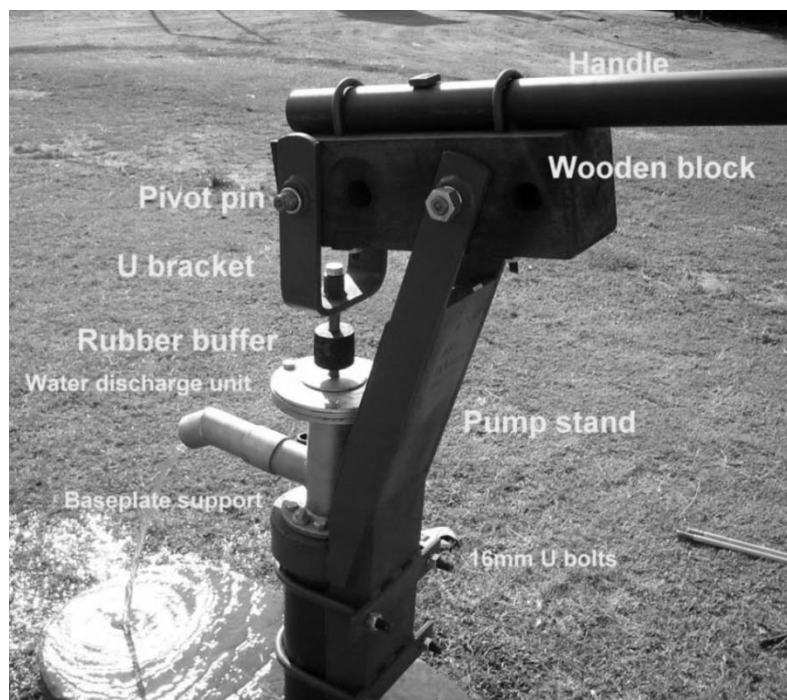

Figure 1: Type B bush pump (Morgan, 2011)

#### Solar (Photovoltaic, PV) pumps

Solar (PV) water pumps are used in Zimbabwe as well as other countries and regions where there is abundant sunlight. They have generally proven to be a reliable and cost effective solution in areas where:

- i. there is widely spread water resources;
- ii. no electricity grid is near, and;
- iii. the fuel and maintenance costs are considerable.

According to (McNelis & Derrick, 1989), the early development of the solar technology was closely linked to water pumping. This is evidenced by a solar water pumping steam engine which was showcased at the Paris Exposition in 1878. Around 1967 one solar pioneer named Tabor wrote that solar cells and thermoelectrics may, some day, pump water for the African native but for the moment, power generators with moving parts appeared to be more practical. During those days solar technology was ideal were it not for the high price and low efficiency. PV modules have been in existence for more than 50 years and mass-production began in 1979. In 1989 a study carried out on 200 PV pumps installed in Mali showed that problems were experienced with early installations but those installed after 1982 were found to be reliable. With improvements in the manufacturing technology and economies of scale, the prices of PV modules have fallen by up to 90% (Baumann & Erpf, 2005). The reliability of PV systems is such that it is possible to typically have 20- to 25-year power warranties with the life expectancy of the system extending beyond 30years. Presenting a practical and financially and technically feasible solution, solar water pumping is becoming more common in agricultural as well as drinking water applications.

The PV modules, normally arranged in an array, generate direct current (DC) which is fed to the battery via a solar regulator to ensure that the battery is charged properly and is not damaged. It is also possible to have pumps which use alternating current (AC) for which the DC will have to be fed through an inverter. For a PV system, a water tank for storage becomes inevitable in order to ensure supply during the times that the pump is not running and also to balance daily (or even weekly) fluctuations in demand. In the presence of storage it becomes possible to have a distribution system installed. Since PV systems are considered to be “Hi-Tech Equipment”, it is highly recommended to consult a solar power specialist before any procurement. An illustration of PV pumping system is shown in Figure 2. Solar pumps can lift up water from boreholes even up to 200m deep, though it is most economical up to a pumping head of 50m. In Africa, experience shows that the PV systems are economical at a pumping head of 50m yielding

## SUSTAINABLE GROUNDWATER DEVELOPMENT

### Pump Technologies – Solar and Hand-powered

a hydraulic head equivalent of up to 800m<sup>4</sup>/day, that is equivalent to (Baumann et al., 2010). As far as maintenance is concerned the most that the community can do is keep the panels and water points clean. The maintenance of the system is done by skilled artisans which is why a community should sign a maintenance contract with the company that installed or the company employed to do so. Generally, the system is vulnerable to vandalism and theft due to the various applications of the solar panels (Hjalmarsdottir, 2012). However, some strategies are being devised to reduce incidences of theft and vandalism with one of the most common being community involvement in the development of such systems to foster sense of responsibility.

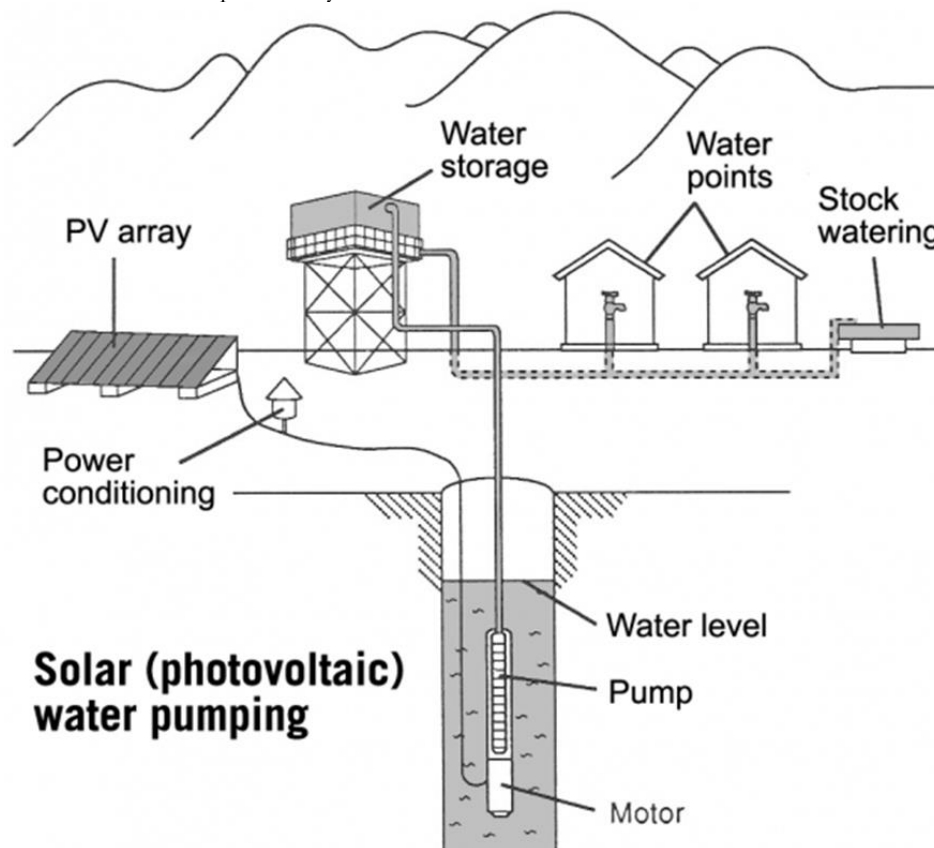

Figure 2: Solar (PV) water pumping system  
([http://www.zimsolar.co.uk/LI\\_rural\\_solar\\_systems.html](http://www.zimsolar.co.uk/LI_rural_solar_systems.html))

During the early development of PV systems it was found out that most systems failed to operate reliably without continuous attendance by skilled technicians to undertake adjustments. This was in the late 1970s as a French company called SOFRETES was pioneering the commercialisation and development of PV systems (McNelis & Derrick, 1989). With further research and improvement over the years, PV systems are now known to be reliable. One such case is in the use of solar powered pumps for irrigation in Bangladesh. Farmers in the pilot area have been switching from diesel run to solar irrigation pumps because of the associated reduced cost of irrigation, reliability and easier maintenance as compared to diesel-run pumps (The World Bank, 2015). It should be noted however that the technical and financial feasibility of PV systems is dependent on quite a number of factors. These include geographic conditions, climate, institutional and social structures (Hjalmarsdottir, 2012). According to Baumann et al. (2010), the system becomes uneconomic for a hydraulic head equivalent of less than 200m<sup>4</sup>/day. Despite the system’s boundary in terms of financial feasibility, the system has got many advantages in other circles like productivity and social life. These are explored in the section that follows.

### Comparison between Type B Bush Pumps and Solar Powered Pumps

The comparison between the two pumps will be discussed under the following interrelated sub-topics:

## SUSTAINABLE GROUNDWATER DEVELOPMENT

### Pump Technologies – Solar and Hand-powered

#### 1. Energy

Both systems do not require fossil fuels and are suitable in areas that have no grid power or erratic power supply and as far as emissions are concerned, both systems can be considered to be clean. The type B bush pump is a manual pump which requires manual labour to draw water and the PV pump makes use of the DC or AC generated by the PV modules. However the PV pump has the advantage of having low labour requirement as compared to the type B bush pump.

#### 2. Operation and Maintenance

The PV system being a motorised pump has low chances of human interaction during operation and less moving parts which correspond to low frequency of maintenance. On the other hand, with the type B bush pump being a manual pump, the chances of human interaction are always and also there are a lot of moving parts in the system which requires maintenance quite often due to frequent wear and tear. The PV system has low frequency of maintenance and so low costs of operation and maintenance. On the other hand, the type B bush pump requires maintenance quite often thereby increasing operation and maintenance costs. In terms of operation the PV system is limited in that it does not perform well in the event of cloudy weather and short winter days. However, the installation of a storage tank helps with ensuring supply during such times. For both systems, maintenance of the systems requires well-trained personnel. For the PV system, the most the community can do is clean the solar panels and keep the water points clean. For further maintenance and repairs, the community can sign a maintenance contract with the supplier of the company employed by the supplier to provide technical backup. For the bush pump, the standard configuration has limited community management but it is very reliable and popular (Baumann et al., 2010). Besides the standard configuration is the open-top cylinder which makes simpler maintenance possible. In cases of breakdown, the solar powered system can be designed to have a storage tank which will act as a buffer during downtime whilst for the Type “B” bush pump people have to find alternative sources of water. It should be noted however, that the storage tank will allow for some time to get the pump system fixed before people start seeking for alternative water sources.

#### 3. Costs

The major limitation of the PV system is the high initial capital cost. The investment cost of a PV system is dependent largely on the power requirement per litre and so it is proportional to the total pumping head and water flow. Usually the point at which the PV systems become economically viable depends on the application and geographic location. According to Baumann et al. (2010), the experience from most African projects has shown that for heads of up to 50m and about 800m<sup>3</sup>/day (product of output and head), the PV systems are viable. For applications of less than 240m<sup>3</sup>/day, handpumps (includes type B bush pump) become more economically viable (Baumann et al., 2010). Due to the high potential of the type B bush pump to be manufactured locally, the cost of setting up type B bush pump becomes lower. Normally, the economic viability is seen in the lifecycle costs. As highlighted earlier, PV systems have low maintenance costs as compared to the type B bush pump. Therefore, though with a high initial cost, the PV system can turn out to be the more economic option in the long run.

#### 4. Ease of Access

Firstly, the labour requirement makes a huge difference between these two systems. Even though said to be reliable (Morgan, 2011), the type B bush pump being a manual pump requires a lot of labour meaning that it can be difficult for children and the elderly to access water unlike with the use of solar pumps which has low labour requirements being a motorised pump. The most you are required to do when using a solar pumping system is opening a tap to get water allowing for universal access of water. Also, whilst the high labour requirements of the type B bush pump limits the use of water to domestic use and livestock watering probably, the low labour requirement also make integrated use of water possible. The water abstracted can also be used for irrigation purposes in addition to domestic usage and livestock watering. With irrigation comes high probability of crop success and all-year farming becomes a possibility.



## SUSTAINABLE GROUNDWATER DEVELOPMENT

### Pump Technologies – Solar and Hand-powered

Secondly, the location of the water point is limited to the borehole when using the type B bush pump which can mean long walking distances to fetch water. However, with PV systems, it is possible to have a distribution network which allows water points to be brought closer to the households reducing walking distances. Lastly, the number of water points is limited to one in the instance of a type B bush pump corresponding to long waiting hours at the water points whilst in the instance of PV pumping systems the water points can be decentralised to have multiple water points at one location which reduces the waiting times at water points.

The time saved can correspond to increased productivity as the time can be allocated for other activities like:

1. **Education** – Research shows that, the burden of fetching water in rural areas fall mostly on women and girls in rural areas. Due to long waiting times and long walking distances, some girls have had to drop out of school. A story is told of Mrs Juliet Ngwenya of Manjolo village, Binga District, Matabeleland North Province in Zimbabwe, who dropped out of school at the age of 8, partly because she had to help her mother to fetch water from an unprotected well 5 km away (Nyamanhindi, 2015). Because of the location of the bush pumps, long walking distances to and fro can cause girls to drop out of school depriving them of education which is essential for individual as well as community development. With water access made easier by use of PV systems, girls can be able to help with fetching water and afterwards be in a position to go to school in the morning as well as fetch water after school.
  2. **Farming** – due to the ease with which water can be accessed using PV systems, time and strength saved in getting water can be invested into farming activities. Coupled by the development of irrigation systems, there is increased likelihood of crop success. The livelihood of the community is bound to improve. This is highly unlikely with the use of type B bush pumps which require taxing labour and can be remotely located making it hard to convey water to farmlands as well as the livestock.
  3. **Recreation** – due to time savings enabled by the use of PV systems, people can get time to engage in recreational activities such as sewing, knitting, reading a book and so forth. This contributes immensely to the emotional as well as physical well-being of the people and places people in a position in which they can focus more on their development and that of the community.
  4. **Improved sanitation and hygiene** – If water can be accessed within short distances and reasonable time, as the case can be with the use of PV systems, then sanitation improves as well. One example is that people can afford to spare water to wash hands after toilet use as water is easily accessible. This will in turn help in the prevention of sanitation-related diseases thus improves health of the people in the community. Another improvement in health is that due to the ease access to water, nurses can focus more on their job rather than being concerned of where to find water for their work. In Gutu, Masvingo Zimbabwe, after the diesel pump at Mazuru Clinic had broken down; nurses had to walk long distances to fetch water before they began work each morning. As quoted by Magrath (2015), Ratiel Chikuvire of Mazuru Clinic, Gutu, Masvingo, Zimbabwe said that they always had problems with maintenance of the diesel pump and in early 2000 the pump broke down taking six years for it to be repaired. Therefore, the clinic’s staff had to go to Dopota Primary School 5km away to get water before commencing work each morning. With the introduction of a PV water pumping system. Ms Chikuvire went on to say: ‘Ever since the solar water pumping system was installed we have never faced any water challenges. We switch the system on for an average of two hours per day and all the tanks will be filled with water, which can last for three days’.
  5. **Other** – An additional advantage is that the same PV modules that are used for water pumping can also be used to provide electricity that can be used for lighting as well for the water points and even some surrounding houses.
- In summary, the replacement of Type B bush pumps with solar-powered water pumps will bring certain overall development of a community.

### Conclusions and Recommendations

## SUSTAINABLE GROUNDWATER DEVELOPMENT

### Pump Technologies – Solar and Hand-powered

From the above discussion there are points which stand above others. Viewing the issue of replacing Type B bush pumps with solar-powered (PV) water pumps will seem impractical from the initial investment point of view. However, other aspects such as improved livelihoods in the rural communities suggest that replacing type B bush pumps with solar (PV) water pumps is an investment for a worthy cause. The benefits of PV systems discussed earlier in the comparison the type B bush pump and PV pump can be summarised as:

- Low labour requirements;
- Low operation and maintenance costs
- Universal access to water;
- Improved productivity;
- Improved access to education for girls, and;
- Improved health.

With the introduction of PV systems, the stories of long walking distances and enduring long waiting hours can be a thing of the past bringing the much desired women empowerment as well as poverty alleviation. Even though susceptible to theft and vandalism, measures can be put in place to ensure that PV systems are kept secure. Over and above all, it is important to note that the performance of PV systems is dependent much on the geographic location and climatic conditions and so there will be areas where the system may be infeasible in terms of the costs and the output of the system. In such areas, it is encouraged that other types of pumps be explored. Zimbabwe has already begun the journey towards the transformation of lives by the introduction of solar-powered technology not only for water pumping but for electricity as well. Hopefully, this technology will continue to be replicated, thus ensuring that more people can enjoy the benefits of PV systems.

### Acknowledgements

I would like to warmly thank my colleagues at Hazen Engineering for their efforts in looking for information used in this paper as well as their contribution in the reviewing of the paper. If it was not for your contribution, this would not have been possible.

### References

- Baumann, E. & Erpf, K., 2005. Rural Water Supply Technology Options - Handpumps, Mechanised Pumps and Surface Water. Rural Water Supply Network.
- Baumann, E., Montangero, A., Sutton, S. & Erpf, K., 2010. WASH Technology Information Packages - for UNICEF WASH Programme and Supply Personnel. Copenhagen: UNICEF.
- de Laet, M. & Mol, A., 2000. The Zimbabwe Bush Pump: Mechanics of a Fluid Technology. *Social Studies of Science*, 30(2), pp.225-63.
- Gono, V., 2016. Solar powered irrigation panacea to drought in Gwanda. [Online] Available at: <http://www.sundaynews.co.zw/solarpoweredirrigationpanaceatodroughtingwanda/> [Accessed 13 April 2016].
- Guzha, E., Chimbunde, E., Smith, S. & Khoza, S., 2007. Technologies for Multiple Use of Water Experience. Harare: Mvuramanzi Trust.
- Hjalmarsdottir, E.H., 2012. Solar powered pumping technologies in Rural Water Supply: Case Study from Kunene Region, Namibia. [Online] Practical Action Publishing Available at: <http://www.practicalactionpublishing.org> [Accessed 25 April 2016].
- Magrath, J., 2015. Transforming lives in Zimbabwe: Rural Sustainable Energy Development Project. Oxfam.
- McNelis, B. & Derrick, A., 1989. Solar Water Pumping: Clean Water for Rural Areas. In 2nd ASEAN Science and Technology Week. Manila, 1989.
- Morgan, P., 1990. Rural Water Supplies and Sanitation. London: Macmillan.
- Morgan, P., 2011. The Zimbabwe Bush Pump (B type) Installation Manual with notes on maintenance. Harare: Aquamor Pvt Ltd.

## SUSTAINABLE GROUNDWATER DEVELOPMENT

### Pump Technologies – Solar and Hand-powered

Nyamanhindi, R., 2015. The burden of thirst: water challenges increase inequality among women in rural Zimbabwe. [Online] Available at: [http://www.unicef.org/zimbabwe/media\\_15918.html](http://www.unicef.org/zimbabwe/media_15918.html) [Accessed 15 April 2016].

Sibanda, W., 2015. Solar powered sand abstraction and borehole pumps technology. [Online] Available at: <http://www.bestclimatepractices.org/practices/solarpoweredsandabstractionandboreholepumpstechnology/> [Accessed 13 April 2016].

The World Bank, 2015. Solar-Powered Pumps Reduce Irrigation Costs in Bangladesh. [Online] Available at:

<http://www.worldbank.org/en/results/2015/09/08/solarpoweredpumpsreduceirrigationcostsbangladesh> [Accessed 21 April 2016].

ZERA, 2015. Use of Renewable Energy as an alternative source of energy in the Farming sector. In Farmers Indaba Workshop. Harare, 2015. ZERA.

## SUSTAINABLE GROUNDWATER DEVELOPMENT

### Pump Technologies – Solar and Hand-powered

# Solar pump technology: programming insights for sustainable rural water supply

Type: Short Paper

Authors *Emily Bamford*, UNICEF, WASH Specialist, New York, US [ebamford@unicef.org](mailto:ebamford@unicef.org), +1 212 326 7606  
And *Cecilia Scharp*, UNICEF, Senior Advisor Water and Environment, New York, US [cscharp@unicef.org](mailto:cscharp@unicef.org) +1 212 326 303 7957

## Abstract/Summary

Over the past few years, UNICEF Country Offices and their partners have demonstrated a strong interest in implementing solar powered water systems schemes at the community level. A total of 34 countries are currently using solar pump technology in their water supply programmes. Demand from beneficiaries is high, due to minimal day-to-day running costs and the relative durability of the systems. As the price of solar panels decreases and the positive contribution of solar powered systems becomes more evident, it has been vital to take stock of the progress so far and provide recommendations for improved programme implementation and scale-up. The solar pump assessment was carried out in 4 countries (Nigeria, Mauritania, Uganda and Myanmar) from July 2015 – March 2016. The four selected countries have piloted the use of solar pump technology over the past few years with varying degrees of success. Contrary to popular belief, it was found that overall the technology itself is highly sustainable in the longterm. However, significant improvements need to be made to the professionalisation of the sector, including borehole siting and installation, increasing the availability of spare parts and the collection of user fees at the household level.

## Introduction

UNICEF first began piloting solar pumps in off-grid areas more than 25 years ago. Since then, the technology has evolved and the reliability and maintenance requirements have improved significantly. Costs have also decreased as more technology options become available on the market. A total of 34 UNICEF country offices are now using solar pumps in their WASH programmes. The majority of pumps so far have been installed in rural communities, schools and health care centres. Most of the systems studied were small in size (less than 2,000 people), with an average of 30-50 systems installed per country so far.

Solar pumps have close to zero running costs, unlike motorised pumps, which are noisy, polluting and expensive to run. Even though the initial investment for solar pumps is still on average around 20% higher than for motorised systems, solar pumps are becoming more competitive cost-wise with motorised-only pumps where strong market competition exists (Khan 2013). Hossain et al (2015) found that the cost benefit ratio of solar pumps (1.91) was significantly higher than diesel-operated pumps (1.31) when looking at investment beyond the initial five year period. Chandel (2015) similarly found that the investment payback for solar pumping systems was around 4–6 years.

As solar pumping systems increase in popularity with Governments, beneficiaries and donors, it has become vital to take stock of the progress made so far in order to address the challenges and give guidance for improved implementation and scale-up.

## Description of the Case Study – Approach or technology

## SUSTAINABLE GROUNDWATER DEVELOPMENT

### Pump Technologies – Solar and Hand-powered

The solar pump study was carried out in Nigeria, Mauritania, Uganda and Myanmar from July 2015 – March 2016. The four selected countries have piloted the use of solar pump technology over the past few years with varying degrees of success.

The assessment looks at the effectiveness and sustainability of solar pump technology, particularly in regards to the programming surrounding it. The study was carried out in collaboration with local partners (including Government, NGOs and private sector), WASH Committees and beneficiaries. Assessments were carried out through direct observation in 35 communities (6-10 per country) which had been installed anywhere from 6 months to 10 years ago. In Mauritania, Nigeria and Uganda, water was distributed largely via tap stands, in Myanmar, small piped systems were used. Additionally, more than 300 individuals also took part in focus group discussions and key informant interviews which took place at the community, district and national levels.

#### Main results and lessons learnt

The overall findings of the study suggest that the technology itself has significant potential, particularly in communities where sunlight is consistent year-round and where water depth is less than 150 metres (commonly the maximum pumping depth). In communities with low water depths, or in those communities where water demand was very high (due to extremely large numbers of livestock), and not spaced throughout the day, some solar systems experienced challenges. In these situations, hybrid solar pumps (which are also supported by a back-up mechanised pump) should be considered.

The majority of solar pump systems visited (64%) had experienced no major malfunctions since they were first installed. For those that had experienced issues, they tended to be relatively minor in nature (mostly relating to wiring, invertors and controllers). Automated systems (with float switches etc.) seemed to perform better than those which were managed manually. This relatively high functionality rate was in contrast to the handpumps and motorised pumps used in the same regions, which reportedly broke down 2-3 times a year on average.

Most communities reported very good yields, with the exception being on days with extremely heavy cloud cover (ranging from 2-7 days a year across the four countries) or during the dry season when demand was extremely high. Even though yield was reportedly lower during the rainy season, in most communities this was not a significant issue as it coincided with a reduced demand (compared to the dry season) and rainwater harvesting was often being used as a backup. Just 6% of communities of the communities surveyed stated they had year-round problems obtaining sufficient water.

For those systems which reported issues, the most significant challenges can be divided into five main categories;

#### i) Borehole siting and construction

The most common severe problems experienced could largely be attributed to poor borehole siting. Several of the water points visited had lower yields than expected or became dry at certain times of the year, leading to the burnout of key pump components. To save money, it was found that partners would often favour the use of existing boreholes without sufficient testing. The presumable issue of “siltin-up” was also a problem in several cases due to inadequate positioning of screens, inappropriate gravel packs and lack of geotextiles.

#### ii) System dimensioning

The majority of UNICEF programmes use Grundfos SQ Flex and Lorenz PS pump models based on their proven durability, output and cost effectiveness in the long-term. All Government, NGO and private sector partners interviewed named Grundfos and Lorentz as the most desirable brands. Mono and Franklin were also rated highly. Unfortunately, the dimensioning of systems was not always found to be

## **SUSTAINABLE GROUNDWATER DEVELOPMENT**

### **Pump Technologies – Solar and Hand-powered**

optimal – particularly where materials were being procured in bulk and a “cookie-cutter approach” was seemingly being favoured by some partners and didn’t always take into account key factors such as borehole yield, sun hours, the needs of livestock, shading/seasonal fluctuation, peak demand times and population growth over time.

#### **iii) Spare parts supply chain**

In Mauritania and Myanmar in particular, official spare parts were difficult to access and expensive, largely because key brands did not yet have a strong enough presence. In Nigeria and Mauritania there were also complaints of fake spare parts flooding the market. In Myanmar and Mauritania especially, spare parts would usually have to be shipped from the capital – which significantly extended the time it took to repair systems. Taxes were also extremely high on solar pump products, making them less competitive with motorised systems. In Nigeria and Uganda, markets were more extensive, so availability of products (and relative cost) were less of a challenge. Quality control is left up to the contractors/partners who procure spare parts.

#### **iv) Availability of trained technicians and pump mechanics**

In most of the countries visited, there was a significant need to improve technical capacities of Government, private sector and community partners. At present there is a heavy reliance on a small number of qualified technicians, who often reside out of state. Demand for their services is high, meaning that the fixing of minor repairs (which could be easily done at the local level) is both expensive and slow. It is vital that more partners (both public and private) complete hands-on training.

#### **v) Collection and management of user fees**

As the potential costs of repairing a major solar pumps malfunction are high (compared to handpumps for example), it is vital that the community or service provider collect a sufficient amount of user fees to ensure the sustainability and longevity of the system. For UNICEF-supported programmes, this price is determined by individual WASH Committees in consultation with households. Average costs per household varied with an average family in Myanmar paying \$1.50 a month to around \$4.50 a month in Uganda. The majority of households found this to be affordable.

Ensuring the absolute poorest were reached was a challenge. In all of the countries surveyed, communities would often make a provision for the poorest (in the form of free or discounted water) – but this was not always the case.

In most cases, collected user fees were managed by WASH Committees and held in a Community WASH Fund. In the best cases, these funds were held in official bank account and payment log books were maintained by WASH Committees. Households were provided with receipts every time they made a payment.

Where this system worked well (for example in Myanmar) communities had amassed an average of \$500-3000. This was sufficient to cover most repairs. Where surplus funds existed, money was also often being used by communities to support other community-based initiatives or provide low-interest loans. Where WASH Committee capacity was lacking and fees were not being effectively collected, community WASH funds were often insufficient, meaning the community became heavily reliant on external support if the pump malfunctioned.

### **Conclusions and Recommendations**

Results from the UNICEF Solar Pump Evaluation have shown that the technology itself appears to be highly sustainable in locations where sunlight is plentiful and water levels do not exceed depths of 150 metres. The majority of systems had rarely experienced any problems and were an effective method of providing safe water, often in piped form, to thousands of people. The systems were popular with communities, Government and private sector partners due to their very low day-to-day running costs and

## SUSTAINABLE GROUNDWATER DEVELOPMENT

### Pump Technologies – Solar and Hand-powered

long-term durability. In countries such as Nigeria, with a competitive market, initial investment costs were highly competitive with motorised systems.

Compared with other pump types (handpumps and motorised), solar pump breakdowns seem to be far less frequent.

All minor issues were easily fixed, where spare part chains and trained technicians were readily available. Major issues, could almost always be prevented by improved borehole siting, construction and installation.

The successful collection of user fees by communities, to support a solar pump maintenance fund varied in success between communities and countries. It should be noted that all these listed issues are not specific to solar pumps – similar issues are also experienced with other pump types and the general management of water services.

In conclusion, solar pump technology provides an excellent opportunity to support the drive for universal basic water, particularly for those living in the most isolated rural locations - *if* the quality of programming surrounding the technology is effective. More investment needs to be made in improving both public and private sector capacity to install and manage systems, improve the supply of quality spare parts and the professionalisation of the drilling sector as a whole.

### Recommendations

#### 1. Improve the professionalization of borehole siting, construction and development

- It is vital that borehole siting, construction, “development” (following construction) and water quality testing is carried out in a professional manner. Working with the Government to ensure improved selection and training of contractors, in addition to ensuring betterdrilling standards and holding them accountable for poor work is vital.
- Ensuring legally-binding performance-based contracts which focus on long-term results is one way of ensuring the accountability of the contractor

#### 2. Improve system dimensioning

- To avert water shortages, it is vital that the total water needs of the population during peak demand times is accurately calculated prior to installation. Pump capacity, storage and solar panels must then be adapted accordingly. Ensuring sufficient storage (for at least 1-2 days) is vital – in order to providing a buffer during system downtime and days with heavy rainfall.
- Where demand is exceptionally high, a back-up generator (hybrid system) could be used or cheaper, unprotected sources could be developed for use by livestock.
- When upgrading handpump boreholes to solar systems, it is vital that a thorough hydrogeological survey be carried out in order to assess borehole viability and prevent excessive groundwater depletion.

#### 3. Strengthen the solar pump market and spare parts supply chain

- Government monitoring and licensing of registered suppliers must be improved in order to ensure counterfeit parts do not flood the market. Penalties must be established for those selling counterfeit and sub-standard products.

In Myanmar and Mauritania, import taxes were extremely high on solar pump products. Adocating the Government to reduce such taxes is vital if solar pump technology is to become more competitive.

#### 4. Increase the number and capacity of technicians and pump mechanics

## SUSTAINABLE GROUNDWATER DEVELOPMENT

### Pump Technologies – Solar and Hand-powered

- It is vital that all relevant partners complete hands-on training. Major solar pump brands should also play a lead role to play here in training and certifying private sector partners in particular.
  - WASH Committee members and Community Operators would benefit from additional and regularised solar pump training (particularly in regards to day to day maintenance).
- 5. Strengthen the collection and management of user fees at the community level**
- Ensuring sufficient training is provided to WASH Committees, particularly in terms of financial management is vital. Establishing key accountabilities of WASH Committees, households, public and private sector is also vital (in the form of a contract) at the start of the project.
  - Ensuring WASH funds are held in an official bank account with statements and amounts collected per month regularly and transparently being shared with community members is vital in order to build trust and encourage the future payment of user fees.
  - In Myanmar, communities contributed a percentage of the initial material and installation costs. This was found to be great way of ensuring ownership and the collection of user fees (to safeguard their investment). This is something which should be encouraged in other programmes also.

### References

- Chandel, S.S, M. Nagaraju Naik and Rahul Chande (2015) *Review of solar photovoltaic water pumping system technology for irrigation and community drinking water supplies*, Renewable and Sustainable Energy Reviews, 2015, vol. 49, issue C, pages 1084-1099
- Khan, Tareek-Al-Islam et al (2013) *The feasibility study of solar irrigation: Economical comparison between diesel and photovoltaic water pumping systems for different crops*  
<http://ieeexplore.ieee.org/xpl/abstractAuthors.jsp?arnumber=6777844>
- Hossain et al (2015) *Feasibility of solar pump for sustainable irrigation in Bangladesh*, International Journal of Energy and Environmental Engineering 06/2015; 6(2). DOI: 10.1007/s40095-015-0162-4
- NetWAS and Water Aid (2013) *Recommendations for the sustainability and scalability of solar powered water pumping for domestic supply in Adjumani and Kanungu districts of Uganda*  
<http://wasstechnologies.net/ressources/documents/default/6-20-2-1383642719.pdf>



## SUSTAINABLE GROUNDWATER DEVELOPMENT

### Groundwater Resources & Hydrogeology

#### 3.2.3 Groundwater Resources & Hydrogeology

---

# Mapping of suitable zones for manual drilling. An overview of the method and the application as decision tools

---

Type: Long Paper

**Authors** *Fabio Fussi, Letizia Fumagalli, Cheikh Hamidou Kane, Tullia Bonomi*  
*Fabio Fussi, University of Milano Bicocca. Email: [fabio.fussi@usa.net](mailto:fabio.fussi@usa.net). Phone: +39-3338418767*

#### Abstract/Summary

Manual drilling is regarded as a potential low cost solution to increase water supply in Africa, but it can be implemented only under specific hydrogeological conditions. The identification of suitable zones for manual drilling is a condition for an effective promotion and implementation of this technique. National maps of suitable zones have been produced since 2008, with a method based on the analysis of existing data and the integration with the experience of local experts. The method has been modified and improved, in particular with a more systematic procedure for the analysis of data and the integration of indirect environmental indicators. In the mean time different institutions have used these maps and evaluate their quality and their relevance as a decision tool for the promotion of manual drilling. In this paper the method of interpretation and the results achieved in terms of utility of these maps are discussed.

#### Introduction

In several countries of the World the situation of access to improved water sources (supplying an adequate quantity and protected from contamination) is still critical. In this context UNICEF is promoting manual drilling as a suitable low cost technical solution to increase the use of groundwater. Manual drilling refers to several drilling methods that rely on human energy to construct a borehole and complete a water supply (Danert, 2015). These techniques use human energy or a small pump to open a hole.

Manual drilling can provide low-cost but high quality water supply. The main advantages are the possibility to be implemented with locally made tools, the cheap cost and the possibility to transport the required equipment in remote areas, where access with mechanized drilling machine is difficult.

Although different techniques for manual drilling are available, they can be applied only where shallow geological layers are relatively soft and water table is not too deep. Therefore the promotion of manual drilling to improve water supply requires a preliminary identification of those zones with suitable hydrogeological conditions.

#### Description of the Case Study – Approach or technology

In the framework of its program to promote manual drilling in Africa, UNICEF carried out a preliminary study to identify suitable zones at country level. This study has been completed between 2008 and 2012 in 15 countries (Benin, Central African Republic, Chad, Ivory Coast, Liberia, Madagascar, Mali, Mauritania, Niger, Senegal, Sierra Leone and Togo between 2008 and 2010; Zambia in 2010; Burundi in 2011, Guinea Conakry in 2012) with a similar approach. However, the methodology was adapted to the specific context of each country (morphology, geological environment, size of the country and scale of work, etc.) and to the available sources of information.

## SUSTAINABLE GROUNDWATER DEVELOPMENT

### Groundwater Resources & Hydrogeology

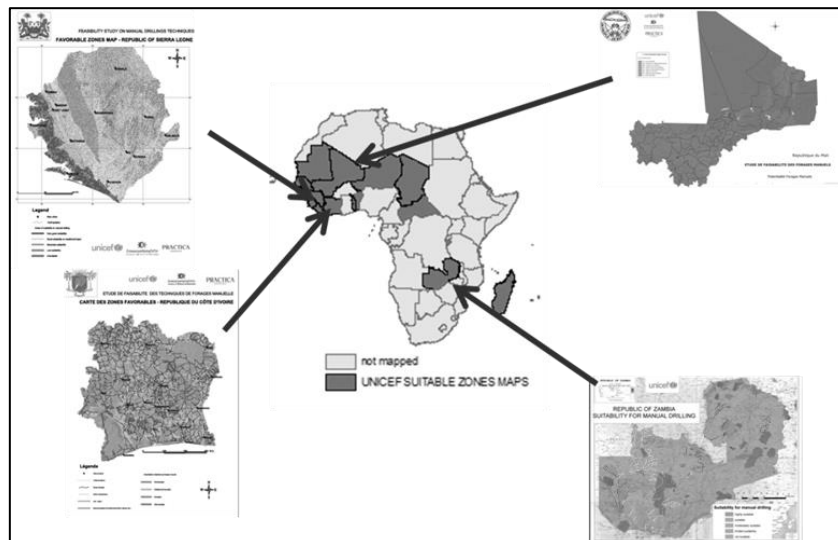

Fig.1: countries where national map of suitable zones for manual drilling has been completed and examples of maps

The goal of national mapping of suitable zones for manual drilling was the definition of regions with high potential for this technique; therefore the level of details of the study was consistent with this goal, but was not oriented to precise identification of position for drilling.

Another specific research project was carried out between 2012 and 2014 to improve the method of interpretation, in the framework of the UPGRO (Unlocking the Potential of Groundwater for the Poors) program, through a joint collaboration between University Milano Bicocca (Italy), University Cheikh Anta Diop Dakar (Senegal), Service Nationale de Points d’Eau (SNAPE) in Guinea Conakry and UNICEF. This project, entitled "Use of remote sensing and terrain modelling to identify suitable zones for manual drilling in Africa and support low cost water supply" aimed to integrate indirect source of information derived from remote sensing and terrain modelling to improve the interpretation of shallow hydrogeological conditions. The proposed method was applied in two study areas in Senegal and Guinea. The results of this project contributed to the definition of an improved methodology, leading in the future to more reliable and detailed interpretation, especially in those areas with shortage of direct data. In this section the different aspects of the methodology applied (and its modification from 2008 till now) are explained.

#### Source of data:

The method is based on the integration of existing organized information, obtained from numeric database or hard copy archives, together with qualitative and subjective information obtained from interviews with hydrogeologists, drillers and field technicians, having direct experience of groundwater exploitation.

The main sources of information are:

*Water points data:* this is the main source of systematic data used for the interpretation in the whole set of 15 countries. Database of water points were obtained from each single national water authority. Furthermore, large archives of hard copy documents with relevant details for single water points are available in each country at central level or decentralized.

Different categories of information can be obtained from water points database:

- General inventory of water points: it contains general information for each water point; in this study the following data were generally used: location, type of water point (boreholes or hand dug well), total depth and depth of static water level.
- Stratigraphic logs: they describe the characteristics of each lithological layer found during drilling. Only in few countries were they available for the study of suitable zones for manual drilling in digital format (Zambia, Guinea, Senegal and partially Ivory Coast) and they were extremely

## SUSTAINABLE GROUNDWATER DEVELOPMENT

### Groundwater Resources & Hydrogeology

important for the estimation of shallow hydrogeological features. However large archives of hard copy reports with detailed stratigraphic logs are available; their systematic analysis required a previous work of transforming this information to simple spreadsheet format, therefore it was possible only where more human resources and time were available for the study (Guinea and Senegal)

- Piezometers with time series of water level: since the original information concerning water level is generally recorded at the end of water point construction (therefore it can be older than 20 or 30 years), recent data obtained from piezometers would be extremely important to have an updated vision of ground water depth and identify where present conditions make manual drilling feasible. Unfortunately piezometers data are generally not systematically recorded in national database and time series of static water level are not available

*Thematic maps:* these are often already available in digital format and can be directly integrated in a GIS environment. The most important maps are represented by geological maps (that were available in each country). In some cases (for example Senegal and Guinea ) the existence of good quality morphopedological maps provided more precise information of shallow layers (while available geological maps at national scale show the main rock formation occurring in a specific area, but often they have no specific information about the existence and characteristics of shallow weathered layer covering the main rock). Other maps related to different environmental parameters were also collected and sometimes supported the interpretation (soil maps, land cover and climatic maps). Most of the digital maps were collected directly from local institutions, while only in some cases were these data available online.

The quality of available geological maps was a big problem for different reasons: a) limited geographic details; b) low detail in classification of geological units, therefore putting together rock types having different characteristics related to shallow hydrogeology; c) limited information of shallow unconsolidated layers, the potential target for manual drilling; d) bad quality of the digital file, for example because of uncorrected topology of GIS vector layer or missing classifications of polygons; this necessitated a huge effort for data editing and correction.

*Digital terrain models:* Public digital terrain models available in the web have been used. In general the SRTM 90 m resolution was considered suitable for the extraction of morphological features at the scale of national maps. In case of extremely hilly morphology, the ASTER GDEM 30 m resolution was used (for example in Burundi). The extraction of morphological features through DEM analysis was not implemented everywhere, since in regions with predominant flat morphology their effect on the shallow hydrogeological context is limited (for example in Senegal, Mauritania, etc.)

*Satellite images:* The use of satellite images have been introduced in the study carried out in Guinea (2011-2012) for the national map of suitable zones and in the research project implemented in two smaller study areas in Senegal and Guinea (2012-2014). They have been used for visual interpretation of landscape features (as a support for rapid field survey) and for the multitemporal analysis of indirect environmental indicators. The types of images that have been used are MODIS and LANDSAT, available for free on the web (only the analysis of soil moisture required ENVISAT ASAR data that were obtained for free from European Space Agency).

*Geological and hydrogeological reports:* there is a lack of hydrogeological studies in several countries. They were mainly used in those countries where more time was available for the study and a quick field survey was planned; therefore their contribution was mainly exploited in Senegal and Guinea

*Direct experience of hydrogeologist, drillers and field technicians:* this source of information was highly important, as existing digital database provided limited details of shallow layers (dug wells are generally not reported in water points database, or they don't have any stratigraphic information; in the meantime mechanized borehole logs provide details of deep fractured aquifers and often generic description of overlaying unconsolidated sediments). This experience was collected through continuous discussion about the procedures of analysis between the local and international team of experts in charge of the study, meeting

## SUSTAINABLE GROUNDWATER DEVELOPMENT

### Groundwater Resources & Hydrogeology

with key informants having direct hydrogeological field experience in the country (for example staff of drilling companies, ngos, water authorities and local well constructors in the villages). The different direct experiences and perceptions of shallow hydrogeological features obtained from these informants were drawn on the map and integrated in qualitative analysis in a GIS environment, with the other available data.

*Pumping tests in large diameter wells and geophysics:* They were used only in a small area of Senegal during the UPGRO research project from 2012 to 2014. Pumping tests in large diameter wells provided direct measurements of hydraulic parameters referred to shallow unconsolidated aquifer, allowing a sort of validation of the indirect interpretation obtained from the analysis of geological maps and water point data; these parameters are useful to obtain an approximate estimation of the potential yield that can be extracted from hand drilled wells. Geophysics was tested in Senegal with the goal of obtaining a stratigraphic model where borehole logs were not available. However pumping tests and geophysics survey require time, therefore they cannot be considered appropriate tools for mapping suitable zones for manual drilling at national level. Still, they can be interesting methods to downscale the study to specific regions and the more precise identification of positions for drilling.

#### Method of interpretation

The original method of interpretation (Fussi, 2011; Fussi, 2013) used a standard schematic approach that was adapted to the hydrogeological context and the availability of data in each country. In the first round of countries (between 2008 and 2010) the procedure was based only on collection, editing, organization and analysis of existing digital data, integrated with interviews with key informants. No field survey was planned and the study was completed through remote collaboration between local experts and international consultants. This procedure has been gradually modified after 2009, mainly in the following aspects:

- A quick field survey to recognize main geological features at regional level and collect information from water technicians active far from the capital. This was introduced in Liberia, Burundi, Guinea.
- The integration of relevant data available only in hard copy (in particular stratigraphic logs) with a preliminary transformation in digital format. This was possible in those countries where more human resources and time were available (in Guinea and at regional level in NorthWestern Senegal).
- The analysis of large diameter wells (direct observation of water level, discussion with villagers concerning water level fluctuation and lithology found during excavation); this part was introduced in 2011 for the map of Guinea.
- A semi quantitative approach in the characterization of shallow exploitable layer.
- The execution of pumping tests in large diameter wells.
- The integration of different sources of information and the extraction of indirect parameters.

These last three points were tested during the UPGRO research project in two test areas in Senegal and Guinea but they have not been applied for the national maps completed in the framework of UNICEF program

The original criteria to assess suitability for manual drilling derived from the combination of three aspects (Fig.2):

- *Geological suitability*, related to the hardness and permeability of the first layers of rock formations, approximately the first 30 meters. Manual drilling techniques are generally suitable for unconsolidated sediments, but not able to drill boreholes in hard rock (although some percussion techniques could break hard layers); furthermore manual drilling is not suitable in unconsolidated materials having low permeability, since in these situations the small diameter and the limited depth of the borehole can lead to low yield;

## SUSTAINABLE GROUNDWATER DEVELOPMENT

### Groundwater Resources & Hydrogeology

- *Suitability according to water depth*, related to the depth where exploitable water strikes can be found. It has been considered that manual drilling is generally a suitable technique when exploitable water is not deeper than 25 m (although in specific situation manual drilling has been applied up to 100 meters);
- *Geomorphological suitability*, referring to the existence of morphological features that facilitate the accumulation of unconsolidated materials, the presence of thick weathered layers and shallow water table; such features are generally associated with bottom of the valleys and sometimes with flat areas having limited slope.

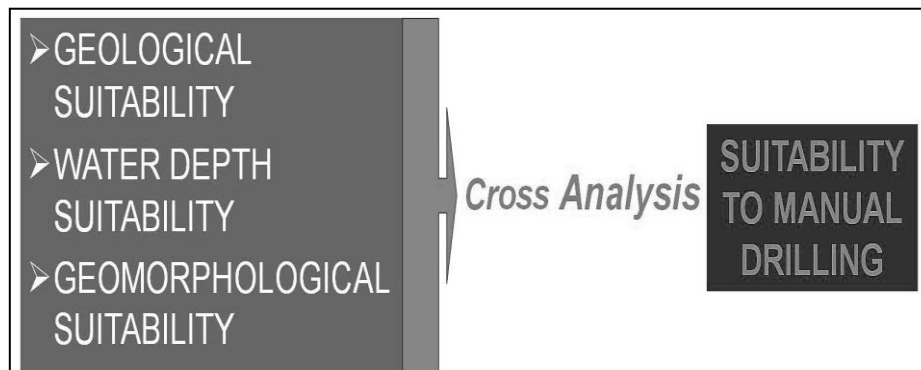

Fig.2: Schematic procedure for the estimation of suitability for manual drilling

The aspect of water quality was partially considered in the assessment of suitability because the main problem for shallow hand drilled wells is related to organic contamination, from bad hygienic condition. Concerning specific problems of chemical water quality due to hydrogeological context (like high salinity, arsenic, fluoride, etc) there is no generally sufficient data to characterize the different regions (water quality information is almost absent from groundwater database) and those data available refer to deep borehole (exploiting different aquifers, with different water chemistry). However in the map of suitable zones for each country there was specific indication of those regions where local experts agreed that problems of water quality could arise.

An assessment of the expected degree of “reliability” of the interpretation was sometimes indicated in the final maps. In those areas with lack of previously existing data and limited direct experience of exploiting shallow aquifer the class of suitability for manual drilling was assigned but it was suggested that a revision be carried out once more data were available. In this sense the feedback obtained from the future construction of manual drilled wells (and consequently a precise collection of information during this activity) is considered of great importance.

This method of assessing the suitability for manual drilling was conceived between 2008 and 2010 (with adjustments from the first attempt in Madagascar to the last country in the initial sample of 12 maps). Limited previous models could be taken as reference (in particular because of the geographic extent of mapping at country level). The main limitations of this method could be considered:

- The interpretation is based on a qualitative estimation, mainly based on subjective perception of experts and visual observation of water point data; a systematic and quantitative procedure to elaborate existing data is limited
- The assessment of shallow hydrogeological conditions cannot be considered reliable in case of shortage of previously existing data (water point data, direct field experience).

The UPGRO research project tried to find some possible solution and proposed an innovative approach under different aspects: a) a systematic and semi quantitative elaboration of stratigraphic logs and the extraction of a set of textural and hydraulic parameters, leading to an evaluation of the potential for exploitation of shallow aquifer; b) direct measurements of hydraulic conductivity of shallow aquifer through pumping test in large diameter well; c) the use of remote sensing to extract indirect

## SUSTAINABLE GROUNDWATER DEVELOPMENT

### Groundwater Resources & Hydrogeology

environmental parameters (like vegetation, soil moisture, thermal inertia) that can be put in relation with shallow hydrogeological conditions through a multivariate statistical approach (fig.3) or visual interpretation of satellite images. A full explanation of this method is available in Fussi(2015)

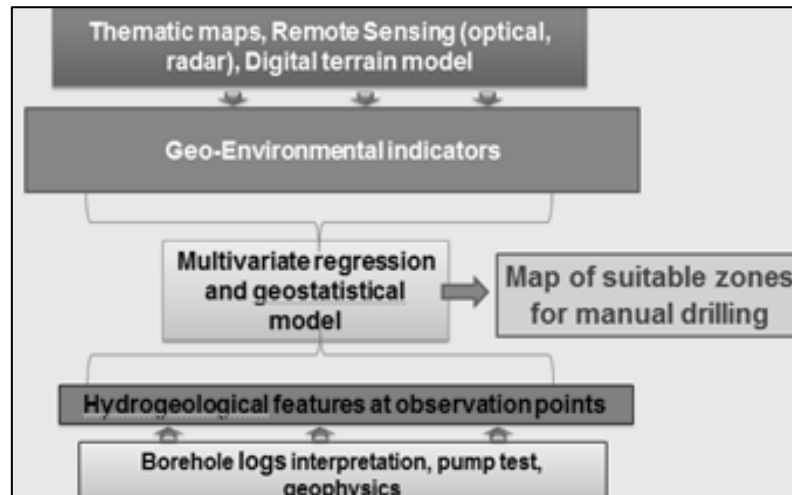

Fig.3: relation between environmental indicators and shallow hydrogeological condition

### Main results and lessons learnt

The main outputs of this work are a series of maps and report specific for each country (most of them are available on the UNICEF website at [http://www.unicef.org/wash/index\\_54332.html](http://www.unicef.org/wash/index_54332.html)). The maps and reports have been validated by national institutions and used for the definition of national strategy for the promotion of manual drilling.

Concerning the UPGRO research project carried out between 2012 and 2014, the final results have been presented in Dakar in April 2014 and are available at <http://www.rural-water-supply.net/en/resources/details/663>

The analysis of the results of this process has considered two main aspects: a) the utility of these maps and reports as a decision and planning tool for the implementation of manual drilling; b) the quality of the maps in terms of reliability of the interpretation. For this analysis the feedback received from the countries that participated in this activity and the technical analysis from a group of experts who collaborated in the study have been considered.

In order to obtain a feedback from each country concerning their perception of quality of the national map and how this map has been used as a decision tool for the definition of national strategy for the promotion of manual drilling, the WASH section of WCARO regional UNICEF office in Dakar sent a questionnaire (table 2) to all those countries that were interested in manual drilling (some of them had already completed the national map of suitable zone while others have not implemented this activity). The countries that filled the questionnaire are: Benin, Burkina Faso, Ivory Coast, Guinea, Madagascar, Mali, Mauritania, Niger, RCA, RDC, Senegal, Chad, Togo, and Zambia. Furthermore two webinar conferences were held (for French and English speaking countries) on 9 April 2015, with participation of more than 10 countries. A final input was obtained from key informants consulted in August 2015.

Table 1: Questionnaire concerning mapping of suitable zones for manual drilling

COUNTRIES WHERE NATIONAL MAPPING HAS BEEN COMPLETED
Have you (in UNICEF) used the report, map or data collated, and if so, for what?

## SUSTAINABLE GROUNDWATER DEVELOPMENT

### Groundwater Resources & Hydrogeology

Have other stakeholders in the country used the map or data collated, and if so, for what?
Have the report and maps been useful for the planning of manual drilling program implementation, and if so how?
Did you find the information of the maps and report generally correct?
What would you improve about the reports, maps or data collated?
What would you improve about the mapping process?
<b>COUNTRIES WHERE NATIONAL MAPPING HAS NOT BEEN DONE</b>
Do you think that such reports, maps and data would be useful?
What would you like to know about the reports, maps or data collated?
What would you like to know about the mapping process

The main relevant aspects obtained from the analysis of the answers are:

#### Use of the map as decision tool for manual drilling strategy

The national maps of suitable zones for manual drilling have been used in several countries where this activity was completed by UNICEF; their main application has been the definition of national strategy in agreement with the Government and the implementation of manual drilling programs in selected regions. Other stakeholders have used these maps (for example the Spanish Cooperation in Mauritania, World Bank in Togo).

The selection of zones for the promotion of manual drilling and the definition of strategy for the implementation have partially taken into consideration the results of the mapping depending on the country:

- In Madagascar the coherence between manual drilling strategy and results of the map could be improved. The programme PEAR (Programme d'Alimentation en Eau et Assainissement en milieu Rural) completed 384 positive mechanized boreholes at shallow depth (less than 35 m) and 64% of them are in areas considered partially or fully suitable to manual drilling; but this cheaper technical solution was not included as an option in PEAR strategy; in the meantime 75% of manual drilled wells have been constructed in regions with high priority for water needs, but with low suitability for manual drilling. Furthermore some organizations that could have played an important role in the implementation of manual drilling in the country were not fully informed about the results of the mapping study.
- In Niger manual drilling was promoted and applied initially in a pilot area (region of Zinder) but later it was expanded in other regions (Maradi, Tahoua, Diffa) on the basis of the map, obtaining good results.
- In Mali the results of the map were taken into consideration for the implementation of a pilot manual drilling program in suitable zones of Mopti region (43 boreholes drilled between 2013 and 2015); after this first positive experience the Ministry of Water and UNICEF launched an extended program to increase manual drilling in suitable areas ( 88 wells in Mopti region) and test medium and low suitable zones (30 wells in the regions of Kayes, Koulikoro and Sikasso)

#### Reliability of the map

The perception is that the information is generally correct and allowed a correct identification of zones with good potential for manual drilling. Some partial discrepancy have been reported in Ivory Coast (where the interpretation is evaluated correct for 60-70%) and Guinea (where it has been remarked that the high geological complexity of the country made it difficult to be precise in the national map, suggesting the implementation of more detailed maps). Results in Mali confirmed the zonification of the map: 100% positive results in suitable areas, 50% in moderate suitable, 0% in low suitable.

The main improvements in the mapping process suggested by UNICEF country offices are:

- the consideration of the aspect of water quality in the classification of suitable zones (Mauritania, Chad, Niger), with specific attention for the identification of areas with high salinity in the water
- The production of more detailed maps in the most potentially suitable regions

## SUSTAINABLE GROUNDWATER DEVELOPMENT

### Groundwater Resources & Hydrogeology

- In some areas with hilly or mountainous topography classified as “not suitable” it is possible to find specific locations at the bottom of the valleys where manual drilling can give positive results (for example this was suggested for Western and Northern regions of Ivory Coast and in the Eastern sector of Madagascar). The identification of these zones require maps with more detailed scale, an improvement in the analysis of morphology in the interpretation and in some cases a quick field survey
- In some cases it has been suggested that the GIS files of the map could be accessible for the National Water Authority for an easy overlay on existing topographic maps. Furthermore in Mali They suggested that the data of manual drilled wells constructed could be organized in a database and be used to improve the original delimitation of suitable zones.

The technical group who was in charge of the elaboration of all these maps and the implementation of the research project underlined a series of points concerning the pertinence and validity of the methods of interpretation, taking into consideration both the experience of country maps completed between 2008 and 2012, as well as the results of the UPGRO research project carried out between 2012 and 2014. The following aspects of the technical evaluation are underlined:

- The analysis of stratigraphic logs is crucial for the interpretation of shallow aquifers and the validation of the perception of hydrogeologists and drillers. But this information is still limited in numeric format; therefore the availability of human resources to input the huge amount of hard copy logs in the computer and the elaboration of systematic procedures of codification and analysis of stratigraphic data allow the exploitation of these important data. An example of this tool and a systematic procedure of analysis were developed during the research project (Fussi, 2014)
- Considering the large effort in data input and correction of existing information (the most time consuming task of the whole process), it would be important that the revised database obtained be properly organized, with complete metadata to facilitate the correct use of the information and made available for potential users.
- The information of hand dug wells can provide better information on shallow aquifers and avoid possible bad interpretation based on national water point inventory containing data only from deep mechanized boreholes. This is extremely important in countries where the presence of confining layers (for example Northwestern Senegal, Central Ivory Coast) made it difficult to determine the depth of the water level in the shallow water table. However the information of hand dug wells is generally limited in the database; for this reason it is considered important a quick field survey to check selected large diameter wells and those interviews with persons involved in digging wells in rural areas.

### Conclusions and Recommendations

Since 2008 specific studies to identify suitable zones for manual drilling at national level have been carried out in 15 countries in Africa, and the study in the 16<sup>th</sup> country (Guinea Bissau) is almost completed. The method of interpretation is based on existing information and limited field survey, in order to make it applicable for maps at national scale obtained in a relatively short time (from 2 to 6 months, according to the extent of the country, its complexity and the available information). Several modifications have been introduced, allowing an improvement in the results in those countries mapped in the last years. The results achieved have been in general appreciated in those countries where this study was carried out and have provided valid decision tools for planning the development of manual drilling. However it seems evident that different aspects contributed to the improvement of the mapping process: the integration of different sources of information, the definition of a more systematic method for data processing and an increase in the human and logistic resources to carry out the study.

Considering the limited previous experience in the characterization of shallow aquifers in Africa at regional level, it would be important to share the new future experience that will be done in other countries and exploit the new data that can be obtained from manual drilled wells to improve the maps already completed.



## SUSTAINABLE GROUNDWATER DEVELOPMENT

### Groundwater Resources & Hydrogeology

It is also important (as was indicated by some countries where the national map have been used) to consider the production of more detailed maps in those regions considered suitable for manual drilling and having high priority for improving water supply. Downscaling the scale of interpretation and delivering more detailed maps can be more useful for direct implementation of manual drilling in the field. For this purpose the integration of other sources of information is crucial (like satellite images, selective field survey, etc), it can fill the gap of existing data and provide information with higher spatial resolution compared with existing thematic maps.

It is also important that the large effort to create well organized database and revising the available information (generally having high level of errors) could be used not only for the production of these maps, but also could provide relevant data for further hydrogeological studies.

This work can be considered still in a highly experimental phase and the joint contribution of researchers, decision makers, and drillers to improve the methodology is considered important.

### Acknowledgment

The information contained in this paper have been collected thanks to the collaboration of many people who supported the realization of the mapping in different countries and the analysis of the application of the results in the following phases. I want to thanks in particular J. Gesti Canuto, K.Yao, K.A.Naylor and K.Danert who made possible in 2015 the collect of the first round of perceptions from different countries with the webinar conferences at UNICEF regional office in Dakar; I am also grateful to A.Dembele, X.Gras, P.Jourda and P.Palomino who discussed in details the application of the maps in Mali, Madagascar, Ivory Coast and Niger.

### References

- Danert, K (2015). “Manual Drilling Compendium.” Rural Water Supply Network Publication 2015-2.
- Fussi, F. (2011). Mapping of suitable zones for manual drilling as a possible solution to increase access to drinking water in Africa. 6th Rural Water Supply Network Forum 29<sup>th</sup> Nov-1<sup>st</sup> Dec 2011, Kampala (Uganda).
- Fussi, F., Alvino, R., Caruba, M., Galimberti, L., Marzan, I., Tarrason y Cerda', D., Sabatini, D. (2013). Mapping of suitable zones for manual drilling as a possible solution to increase access to drinking water in Africa through integration of systematized GIS data and local knowledge. Geophysical Research Abstracts, 15, 2013-8937.
- Fussi, F., Bonomi, T., Fava, F., Hamidou, B., Khane, C.H., Faye, G., Wade, S., Colombo, R. (2014). Tangafric: a software for the estimation of textural and hydraulic properties in shallow aquifers from well logs in Senegal and Guinea. Geophysical Research Abstracts, 16, 12154-12155.
- Fussi, F. (2015): Integration of hydrogeological investigation, remote sensing and terrain modeling for the analysis of shallow aquifers in West Africa and the identification of suitable zones for manual drilling. PhD thesis, Univeristy Milano Bicocca. Available at [https://boa.unimib.it/retrieve/handle/10281/89448/131534/phd\\_unimib\\_760910.pdf](https://boa.unimib.it/retrieve/handle/10281/89448/131534/phd_unimib_760910.pdf).
- UNICEF and Practica Foundation. Capitalisation d'expérience sur les forages manuels a Madagascar. September 2012. Unpublished

## SUSTAINABLE GROUNDWATER DEVELOPMENT

### Groundwater Resources & Hydrogeology

---

# Properties of shallow thin regolith aquifers in sub-Saharan Africa: a case study from northwest Ethiopia

---

Type: Short Paper

**Author:** *David Walker, PhD Student, Newcastle University, UK, d.w.walker1@newcastle.ac.uk*

### Abstract

Pumping tests have been successfully conducted on shallow hand-dug wells in two areas of northwest Ethiopia. The drawdown and recovery data were analysed separately providing consistent results confirming suitability of methods. Hydraulic conductivity estimates ranged from 0.2 to 6.4 m/d (mean = 2.3 m/d, median = 1.6 m/d) in the dry season and ranged from 2.8 to 22.3 m/d (mean = 9.7 m/d, median = 6.5 m/d) in the wet season when the water-table was higher. This difference indicates the importance of excavating wells as deeply as possible to increase the likelihood of intercepting more transmissive (water-bearing) layers. Specific yield estimations have a wider range (0.00001 to 0.32) and are more uncertain though the mean of 0.09 (median of 0.08) is reasonable. Estimates of well yield average 0.5 l/s though this increases to >1 l/s in the wet season; giving optimism that small-scale irrigation is achievable, therefore, potentially reducing the reliance on rain fed agriculture. These results from weathered basalt regolith add to the sparse available data on shallow groundwater resources in sub-Saharan Africa. Consistency of results from nearby and distant wells indicates homogeneity of shallow aquifer materials giving a high transferability of findings to other areas of Ethiopia. This knowledge of aquifer properties facilitates modelling for estimating impacts of climate variability and change, and for developing sustainable management strategies for shallow groundwater resources.

### Introduction

It is well discussed that the hydrogeology of sub-Saharan Africa is poorly understood, particularly regarding shallow groundwater resources (Calow et al., 2009, MacDonald et al., 2009, Robins et al., 2006), even though such resources sustain the majority of the continent's population (Lapworth et al., 2013). A knowledge of aquifer properties allows for calculations and models to assess groundwater recharge, abstraction potential, contamination risk, impacts of future climate variability, and management strategies. However, few data are available on shallow aquifer properties for this region (Bonsor et al., 2014).

The most useful shallow aquifer properties are; hydraulic conductivity ( $K$ ) – the ease by which water moves through an aquifer, specific yield ( $S_y$ ) – the volume of water that drains from the aquifer per unit surface area of aquifer per unit decline of the water table (the drainable porosity), and well yield – the rate at which water can be abstracted from a well.

As part of an ongoing project assessing the vulnerability of shallow aquifers in sub-Saharan Africa, pumping tests were first conducted during a field visit to Ethiopia in March/April 2015, timed to coincide with the end of the dry season and period of greatest water scarcity. Further testing was undertaken during a second field visit in October/November 2015 at the end of the wet season. In order to estimate hydraulic conductivity, specific yield and well yield, tests were conducted on hand-dug wells in two locations within the Amhara region (Figure 1). Both drawdown (the drop in water level within the well caused by pumping) and recovery (the increase in water level back to pre-test level following cessation of pumping) were monitored then analysed using alternative methods.

## SUSTAINABLE GROUNDWATER DEVELOPMENT

### Groundwater Resources & Hydrogeology

#### Testing Locations

Seven wells were tested within Dangila *woreda* (Figure 1), benefiting from and enhancing relationships established by a community-based monitoring programme which has been ongoing since March 2014 (Walker et al., 2016). A further well was tested in Robit-Bata *kebele*, 80 km northeast of Dangila *woreda*, close to the city of Bahir Dar.

All of the wells tested were located within weathered basalt regolith above variously massive, vesicular and/or fractured basalt. Tested wells ranged in depth from 3.55 to 10.09 metres below ground level (mbgl) with (often irregular) diameters of around a metre ( $\pm 0.2$  m). Wells are excavated by hand with picks and shovels until the solid geology is hit. Therefore, water column height is considered the saturated thickness of the aquifer and in the tested wells ranges from 0.54 to 3.85 m in the dry season and 1.99 to 6.34 m in the wet season. These ranges of well geometries and water depths are typical of hand-dug wells in the areas. Wells were selected to cover a range of topographies from floodplains, to valley slopes, to higher elevations, in an area of moderate relief within the Ethiopian Highlands.

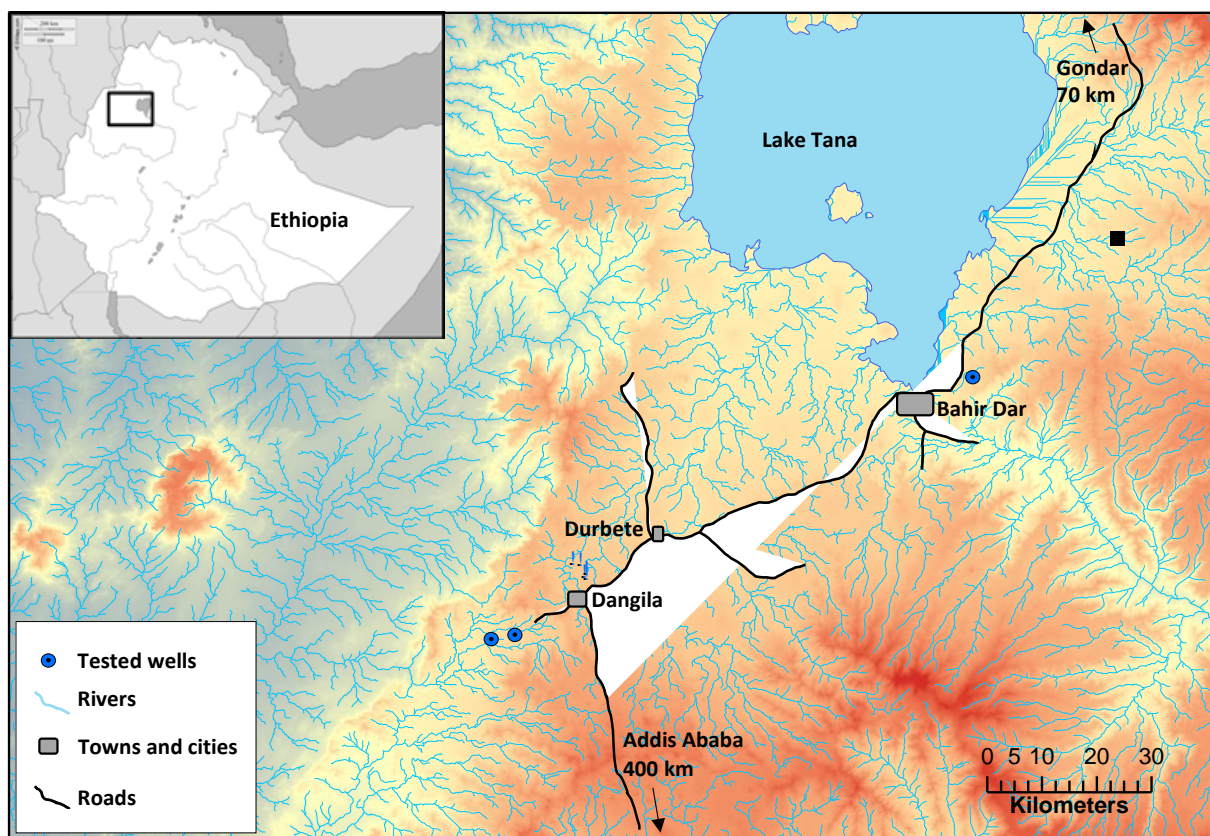

Figure 1. Geographical distribution of testing locations

#### Testing Methodology

Motor pumps were not available, therefore, water was removed from wells using manual methods. Water-lifting incorporated a rope and bucket; the bucket being a modified HDPE water container. At least two people were involved in water-lifting (Figure 2) which helped to maintain a largely constant discharge rate.

## SUSTAINABLE GROUNDWATER DEVELOPMENT

### Groundwater Resources & Hydrogeology

A pressure transducer measuring every two seconds was placed in the well prior to starting a test and water levels were also manually measured using a dip-meter. The volume of the emptying water container was measured in addition to well diameter and depth. The number of buckets abstracted per minute was monitored to calculate the pumping rate. The pumping rate varied between wells from 2 litres/minute to 15 litres/minute (with one exception) dependent on the size of the container and the depth to the water table; the smallest container and deepest water table giving the slowest pumping rate. The test in Robit-Bata *kebele* had a pumping rate of 30 litres/minute being the only tested well with a pulley and double bucket system which leads to much more efficient water lifting.

Water was abstracted until the well water column was reduced by at least 10 %. The necessary time to remove the entire well volume or to reach steady-state conditions with the equipment available would have been excessive and extremely labour-intensive. More importantly, given that the first field visit took place during the period of greatest water scarcity, it would have been unethical to attempt to reduce the water level in the wells to near empty. In order not to waste water, all containers that each household possessed were filled during pumping tests and further water was used for backyard irrigation and for watering livestock. The recovery of the water level was monitored with no additional abstraction.



Figure 2. Photographs of pumping tests

### Test Analysis

Selecting analysis methods was not straightforward. The shallow aquifer here may be unconfined, however, a low-permeability though leaky clay-rich layer is commonly observed in weathered igneous regolith profiles above more permeable material which hosts the aquifer (Sharp, 2014, Taylor and Eggleton, 2001). In addition, it is suspected that fractures in the underlying solid geology are influential. There is further uncertainty over whether the wells are fully-penetrating; wells are generally excavated until solid geology is hit though they may be partially penetrating if a boulder was struck (such boulders are commonly observed in regolith stream bank sections) or where water-tables are shallow (i.e. on floodplains).

The Moench (1985) method was selected because it considers leaky aquifers and large-diameter wells, i.e. well bore storage is included, and is straightforward to use on AquiferWin32 software. The method requires: well geometry, aquifer thickness, pumping rate, and a time-series of drawdown. Given that the period of pumping was quite short and did not reach steady state, only a small portion of curve was available for matching to provide values for hydraulic conductivity and specific yield. Therefore, there is a potential error on the results though it is likely to be less than the natural variation of the aquifer material. However, the specific yield values resulting from this method were often considered impossibly

## SUSTAINABLE GROUNDWATER DEVELOPMENT

### Groundwater Resources & Hydrogeology

low ( $< \sim 1 \times 10^{-6}$ ), as they are computed from early time data which is considered in pumping test analysis to be the least reliable, and have not been included when calculating averages (Table 1).

Recovery data was analysed using nomograms presented by Barker and Herbert (1989) to facilitate application of the solution of Papadopulos and Cooper (1967) to recovery tests on large-diameter wells. The method requires: well geometry, pumping rate and period, drawdown at the end of pumping, and time taken for 25 %, 50 % or 75 % recovery, and provides values for transmissivity (T) (the rate at which water flows horizontally through an aquifer;  $T = K$  multiplied by aquifer saturated thickness) and specific yield. Values for hydraulic conductivity were derived by dividing the transmissivity by the measured saturated thickness.

Potential well yield is considered to be the maximum continuous abstraction, i.e. pumped to steady state, that a well could be subjected to without drying out. In this case, “drying out” is considered to be a water depth of 0.3 m which is the minimum depth from which water could be abstracted using bucket and rope methods or without excessive sediment intake in a motor pump. Well yield (Q) was calculated with the application of the Thiem (1906) equation:

$$Q = \frac{K(H^2 - h^2)}{C \log(R/r)}$$

Hydraulic conductivity (K) was taken from the pumping test analyses, saturated thickness (H) and well radius (r) were as measured prior to testing, water depth (h) was fixed at 0.3 m, C is a constant equal to 0.733, and the radius of the cone of depression (R) was varied from 5-20 m.

### Results

Given the uncertainties over well and aquifer geometry, hydraulic conductivity and specific yield results are sufficiently similar from the drawdown and recovery analyses to indicate suitability of methods (Table 1). The largest differences in properties between testing methods are within the natural variation of the aquifer materials.

Table 1. Aquifer properties determined by pumping tests; K = hydraulic conductivity and  $S_y$  = specific yield. The  $S_y$  results in italics are considered unreliable (see text) and were not used to calculate averages.

		No. of tests	K (m/d)	$S_y$	Well yield (l/s)
End of dry season	<i>Dangila</i>				
	Drawdown	5	0.7 – 5.3	0.03 – 0.12	0.001 – 0.32
	Recovery	5	0.2 – 6.4	0.00001 – 0.32	
	<i>Robit-Bata</i>				
Drawdown	1	0.4	-	0.03 – 0.25	
Recovery	1	1.8	0.029		
End of wet season	<i>Dangila</i>				
	Drawdown	5	2.8 – 6.8	<i><math>7.8 \times 10^{-7} - 3.6 \times 10^{-6}</math></i>	0.21 – 3.5
	Recovery	5	6.2 – 22.3	0.05 – 0.10	

Significantly, the result from Robit-Bata is consistent with those from Dangila confirming field observations of the similarity of the regolith of both areas. This outcome suggests that conclusions reached on the hydrogeology may be transferrable to other shallow aquifers above basalt bedrock throughout Ethiopia. Continuing research is required to determine if findings on the shallow aquifer in

## SUSTAINABLE GROUNDWATER DEVELOPMENT

### Groundwater Resources & Hydrogeology

this region are potentially transferrable across a wider area as studies have shown that regolith has hydrogeologically similar characteristics across a variety of rock types (Jones, 1985).

The mean dry season hydraulic conductivity values derived from all wells using analysis of both drawdown and recovery data is 2.3 m/d with a median of 1.6 m/d, a range of 0.2 to 6.4 m/d and a standard deviation of 1.95. The mean wet season hydraulic conductivity is 9.7 m/d with a median of 6.5 m/d, a range of 2.8 to 22.3 m/d and a standard deviation of 7.19. This disparity between seasons is not only of transmissivity but hydraulic conductivity, therefore, is not explained by greater saturated thickness. Layers of higher hydraulic conductivity must exist within the higher water column during the wet season. The implication of this finding is significant; not only would wells excavated more deeply below the water-table have higher well bore storage, but they are more likely to intercept more transmissive (water-bearing) layers providing greater yield. Estimates of well yield are generally >1 l/s in the wet season when the water column is high though this may drop an order of magnitude during the dry season.

The hydraulic conductivity results are comparable to studies of regolith elsewhere in Africa: Olaniyan et al. (2010) report a range of 0.30 to 9.36 m/d (average: 2.13 m/d) from a study in Nigeria, Taylor and Howard (1998) report a range of 0.3 to 3.0 m/d in Uganda, while 0.05 to 1.5 m/d is reported by Chilton and Smith-Carington (1984) in Malawi. A textbook range for weathered igneous regolith presented by Taylor and Eggleton (2001) is 0.09 to 1.7 m/d.

It is well reported that there are few data on specific yield of regolith, or indeed any, aquifers in Africa (MacDonald et al., 2012). From all seasons and locations the specific yield range of 0.00001 to 0.32 and mean of 0.09 (median of 0.08 and standard deviation of 0.079) is similar to the wide range quoted by Jones (1985) of 0.00001 to 0.1 for Central Africa and higher than the 0.003 reported by Taylor et al. (2010). Bahir Dar University laboratory assessment of density, porosity and field capacity of five bulk samples enabled estimation of a specific yield range of 0.052 to 0.219 for weathered basalt regolith from Robit-Bata *kebele* (D. L. Yilak, personal communication, March 2015). A textbook range for specific yield of regolith presented by Fetter (2001) is 0.15 to 0.3.

### Conclusions

Pumping tests conducted on hand-dug wells in northwest Ethiopia provide mean hydraulic conductivity values of 2.3 m/d in the dry season and 9.7 m/d in the wet season (median = 1.6 and 6.5 m/d), and a mean specific yield value of 0.09 (median = 0.08). These values contribute to the extremely sparse data available in published literature for shallow regolith aquifers in sub-Saharan Africa. Calculations of well yield (average = 0.5 l/s) indicate that penetrating a substantial saturated thickness of aquifer (>3 m below water-table) to maximise water column height is as important for achieving desirable yield as locating areas of high hydraulic conductivity. A well or borehole fitted with a handpump must be able to sustain a supply of >0.1 l/s (preferably 0.3 l/s) to supply a community (MacDonald et al., 2012). Irrigation demand depends on crop type and local environmental conditions, though these are less significant when considering general feasibility. For the range of crops and conditions likely to be encountered at the study site and the short distance of delivery from well to crop, daily water use can be calculated as approximately 1 l/s/ha. Given this calculated irrigation requirement, the well yield estimations give some optimism that small scale irrigation, in addition to the existing community supply, is achievable from hand dug wells in shallow regolith aquifers. Further research is required to determine the transferability of findings, though similarities in results from wells some distance apart and with published results suggest the findings may be transferable to other areas of shallow weathered regolith aquifers across sub-Saharan Africa and certainly to shallow weathered basalt regolith aquifers within Ethiopia. Knowledge of aquifer parameters is vital in constructing models for simulation of climate change impacts and in developing management strategies for sustainable development of shallow groundwater resources.

### References

## SUSTAINABLE GROUNDWATER DEVELOPMENT

### Groundwater Resources & Hydrogeology

- BARKER, J. A. & HERBERT, R. 1989. Nomograms for the analysis of recovery tests on large-diameter wells. *Quarterly Journal of Engineering Geology*, 22, 151-158.
- BONSOR, H. C., MACDONALD, A. M. & DAVIES, J. 2014. Evidence for extreme variations in the permeability of laterite from a detailed analysis of well behaviour in Nigeria. *Hydrological Processes*, 28, 3563-3573.
- CALOW, R. C., MACDONALD, A. M., NICOL, A. L. & ROBINS, N. S. 2009. Ground Water Security and Drought in Africa: Linking Availability, Access, and Demand. *Ground Water*, 48, 246-256.
- CHILTON, P. J. & SMITH-CARINGTON, A. K. 1984. *Characteristics of the weathered basement aquifer in Malawi in relation to rural water supplies*, IAHS Press.
- FETTER, C. W. 2001. *Applied Hydrogeology*, Prentice Hall Upper Saddle River, NJ.
- JONES, M. J. 1985. The weathered zone aquifers of the basement complex areas of Africa. *Quarterly Journal of Engineering Geology and Hydrogeology*, 18, 35-46.
- LAPWORTH, D. J., MACDONALD, A. M., TIJANI, M. N., DARLING, W. G., GOODDY, D. C., BONSOR, H. C. & ARAGUAS-ARAGUAS, L. J. 2013. Residence times of shallow groundwater in West Africa: implications for hydrogeology and resilience to future changes in climate. *Hydrogeology Journal*, 21, 673-686.
- MACDONALD, A. M., BONSOR, H. C., DOCHARTAIGH, B. E. O. & TAYLOR, R. G. 2012. Quantitative maps of groundwater resources in Africa. *Environmental Research Letters*, 7, 7.
- MACDONALD, A. M., CALOW, R. C., MACDONALD, D. M. J., DARLING, W. G. & DOCHARTAIGH, B. E. O. 2009. What impact will climate change have on rural groundwater supplies in Africa? *Hydrological Sciences Journal-Journal Des Sciences Hydrologiques*, 54, 690-703.
- MOENCH, A. F. 1985. Transient flow to a large-diameter well in an aquifer with storative semiconfining layers. *Water Resources Research*, 21, 1121-1131.
- OLANIYAN, I. O., AGUNWAMBA, J. C. & ADEMILUYI, J. O. 2010. Assessment of aquifer characteristics in relation to rural water supply in part of Northern Nigeria. *Researcher*, 2, 22-27.
- PAPADOPULOS, I. S. & COOPER, H. H. 1967. Drawdown in a well of large diameter. *Water Resources Research*, 3, 241-244.
- ROBINS, N. S., DAVIES, J., FARR, J. L. & CALOW, R. C. 2006. The changing role of hydrogeology in semi-arid southern and eastern Africa. *Hydrogeology Journal*, 14, 1483-1492.
- SHARP, J. M. 2014. *Fractured Rock Hydrogeology*, CRC Press.
- TAYLOR, G. & EGGLETON, R. A. 2001. *Regolith geology and geomorphology*, John Wiley & Sons.
- TAYLOR, R., TINDIMUGAYA, C., BARKER, J., MACDONALD, D. & KULABAKO, R. 2010. Convergent Radial Tracing of Viral and Solute Transport in Gneiss Saprolite. *Ground Water*, 48, 284-294.
- TAYLOR, R. G. & HOWARD, K. W. F. 1998. The dynamics of groundwater flow in the regolith of Uganda. *International Contributions to Hydrogeology*, 18, 97-114.
- THIEM, G. 1906. *Hydrologische Methoden: Dissertation zur Erlangung der Wurde eines*, JM Gebhardt.
- WALKER, D., FORSYTHE, N., PARKIN, G. & GOWING, J. 2016. Filling the observational void: Scientific value and quantitative validation of hydrometeorological data from a community-based monitoring programme. *Journal of Hydrology*, 538, 713-725.

#### Contact Details

Name of Lead Author: David Walker

Email: d.w.walker1@newcastle.ac.uk

SUSTAINABLE GROUNDWATER DEVELOPMENT

Groundwater Resources & Hydrogeology

---

# Inexpensive Resistivity Instruments for Groundwater Exploration: Experiences of African National Geophysical Teams

---

Type: Long Paper

**Authors** Christelle Kwizera (Water Access Rwanda & Water4, [christelle@water4.org](mailto:christelle@water4.org)), James A. Clark, Matthew Hangen, Randy Jones, Ray McKee, Rick Page

## Abstract/Summary

Geophysical technology is an important component in exploration for groundwater resources and siting of wells. Electrical resistivity methods have often been used with great success by hydrogeologists to determine depth to aquifers and to improve the probability of completing a successful water well. However the excellent resistivity instruments now commercially available cost many thousands of dollars and so are unavailable to low-budget well drillers in the majority world. We have developed a simple resistivity instrument that can be assembled for less than \$800. Our free software on a laptop aids in interpretation of the resistivity data. The Water4 organization has used this method in siting over 150 wells. Accurate records exist for 64 of these wells indicating that the predictions from the inexpensive resistivity device were correct 86% of the time. Nine (9) teams are currently working in six (6) African countries with varying geophysical settings of mountain ranges, rift valleys, plains, and sedimentary basins.

## Introduction

Groundwater is an important source of safe water for rural communities. Where springs are not prevalent, wells provide the usual means of accessing this resource. However, it is expensive and time consuming to drill or dig a well and the desired outcome of a successful well may not be achieved. Choosing a well drilling site is therefore very important. Low-budget drillers often consider offset distances from surface sources of contamination as the only guideline for siting a well. In Tanzania well drillers using a small LS-100 mud rotary drill rig drilled 50 wells in one year but 18 of those wells did not produce water because the decomposed granite aquifer overlying hard granite bedrock was either too shallow and therefore above the water table or too deep, beyond the depth limit of the drill rig (Clark et al., 2011). These dry boreholes could have been avoided if accurate subsurface properties had been known. Geophysical methods are a common means of interrogating the subsurface and have been shown to be highly effective. In one study in Zimbabwe using a data set of 370 wells the success rate increased from 50% to 85% when commercially available geophysical resistivity instruments were used for borehole siting (R. D. Barker, et al. 1992). Other authors have similarly stressed the usefulness of geophysical methods to site water wells (MacDonald et al., 2005, Kirsch, 2006, Rubin and Hubbard, 2006, Clark et al, 2011, Clark et al. 2016). In fact some national policies now require that a geophysical survey be performed and reported at each well site. Despite this general appreciation for geophysical methods the use of these instruments has been limited due to their considerable expense. The purpose of this paper is to describe the successful use of a very inexpensive resistivity instrument by African geophysical teams supporting Water4 water well drilling. The instrument cost of \$800 is well within the budget of any well driller.



SUSTAINABLE GROUNDWATER DEVELOPMENT

Groundwater Resources & Hydrogeology

Context, aims and activities undertaken

*The Inexpensive Resistivity Instrument:*

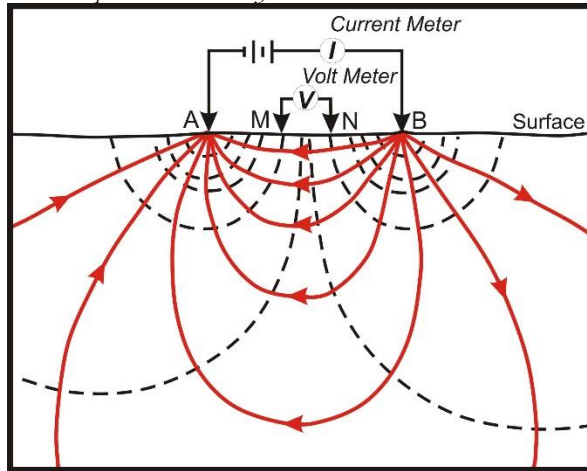

Figure 1: Illustration of current lines (solid) and voltage contours (dashed). Current is supplied through electrodes A and B. Voltage is measured at electrodes M and N. The distance between electrodes A and M, between M and N, and between N and B is equal to “a”, the a-spacing. For vertical electrical sounding “a” increases allowing current to penetrate deeper. For horizontal electrical profiling the electrode a-spacing is maintained at a constant value while all four electrodes are moved laterally.

Figure 1 illustrates the relatively simple function of any resistivity instrument. A current generated by the device enters the ground through two electrodes (A,B). This current,  $I$ , is measured by an ammeter. While the current flows the voltage drop,  $V$ , between two other electrodes (M, N) is also measured. As the spacing between the electrodes,  $a$ , increases the current penetrates deeper into the earth. The apparent resistivity is defined as  $\rho_a = 2\pi aV/I$ . If the earth is homogeneous then  $\rho_a$  remains constant as the a-spacing increases. But if the resistivity changes at depth, either through lithology change or water saturation, then this change is reflected in a change in apparent resistivity. There are two complicating factors however. If the current flows for more than a few seconds in one direction an induced charge builds up at the electrodes which affects the current magnitude. Also the earth has a natural voltage, the spontaneous potential, which affects the measured voltage. Both of these negative influences can be avoided if the current reverses about once every second. The reversing current eliminates charge buildup and if an even number of reversals occur (e.g. 4 of them) the average voltage value eliminates the spontaneous potential effect. This method is common to all resistivity instruments.

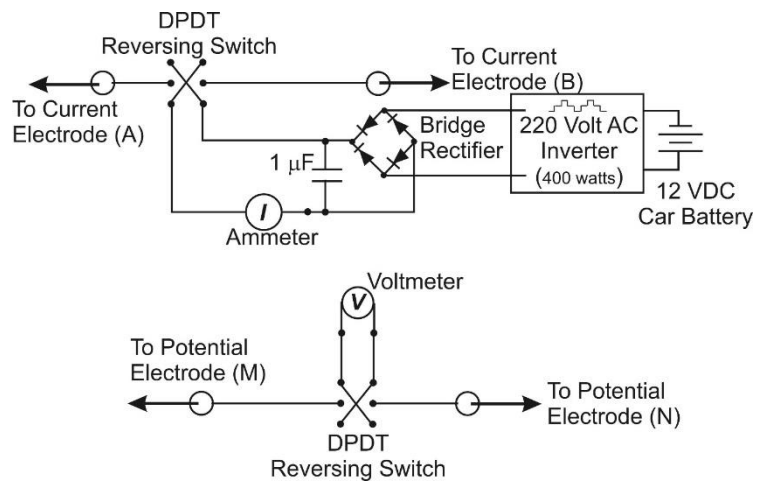

Figure 2: Circuit schematic of the inexpensive resistivity instrument. Total cost, excluding the inverter and car battery, is under \$25. DPDT is a double pole double

Therefore in principle the instrument is very simple (Figure 2) and consists of an inverter to increase the voltage from a 12 V battery to 220 volts AC; a bridge rectifier and capacitor to produce a high DC voltage; two reversing switches to manually reverse the current and the voltage reading; and two digital multimeters to measure current and voltage. The excellent commercial resistivity instruments (e.g. ABEM Terrameter, Sting) automatically reverse the current and measure the current and voltage with no operator input. The value of apparent resistivity is then displayed, requiring no calculations. These instruments are also capable of very high voltage generation and therefore deeper current penetration. Our opinion is that the added convenience of operation and increased knowledge of deeper earth structures is not necessary for well siting under most rural situations where a hand pump is to be installed and a low-cost drilling method is used. If an operator is willing to manually switch the current four times, read the multimeters,

## SUSTAINABLE GROUNDWATER DEVELOPMENT

### Groundwater Resources & Hydrogeology

average the results, and do the simple calculation for  $\rho_a$  then adequate estimates of apparent resistivity are possible. Figure 3 shows the excellent agreement between the apparent resistivity data of our simple instrument to a Sting commercial resistivity instrument at a site in Nigeria. Although the maximum depth achieved with our instrument is somewhat dependent upon the actual resistivities of the earth layers, our experience has been that depths less than 35 m can be measured reliably. Under most rural conditions this depth is not a limitation as manual drillers also prefer drilling within this depth range. The majority of Water4 wells in sub-Saharan Africa have depths between 18 and 25 m.

Although the measurement of apparent resistivity does not require a laptop computer, the interpretation of a subsurface earth model (i.e. layer thickness and associated resistivity) is most easily determined using software to fit the data with the most likely earth resistivity model. Again excellent commercial software is available that can produce 1-, 2- and even 3-dimensional reconstructions of the subsurface. But we have developed free software for use on a Windows based laptop predicting one-dimensional vertical earth structure usually called vertical electrical sounding (VES). The software also calculates apparent resistivity from the raw data and plots the data (<http://cs.wheaton.edu/~jclark>). Most of the instrument cost is the wire cable connected to the electrodes. The inverter can also contribute significantly to the total expense. The digital multimeters do not have to be of high quality and the electrodes are 10-inch lag screws or nail spikes. The “control” box is the least expensive of all items. The entire system can be assembled in a few hours with a total cost less than \$200. But our experience is that continual use under harsh African conditions requires a more robust unit that costs \$800 (Figure 4). A low-end PC laptop computer can often be purchased for under \$300. In addition to its use in resistivity data interpretation, the laptop can also be used for writing reports, calculating spreadsheets, communicating with email, and making presentations. Free open source geographic information system (GIS) software such as QGIS (2014) or SAGA (2015) can also be used on the laptop to record and display exact locations of wells and associated resistivity and well log data.

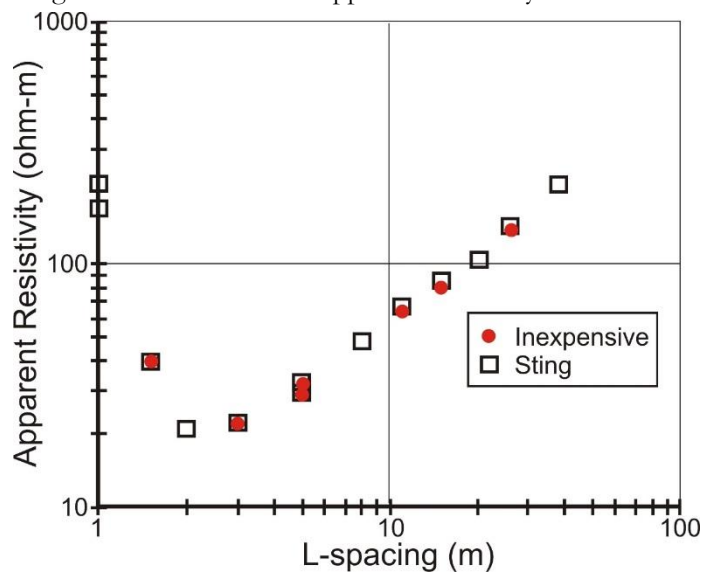

Figure 3: Comparison of apparent resistivity measurement between the commercial Sting instrument and our inexpensive device. There is excellent agreement in this vertical electrical survey.

#### Context and Activities:

Water4 is an organization committed to sustainable, low-cost solutions through empowerment and capacity building of the private WaSH Enterprises. The organization requires local community involvement as an important component of sustainability and only works through existing local organizations, businesses, and non-profits. In Africa, Water4 currently partners with organizations in the following countries: Togo,

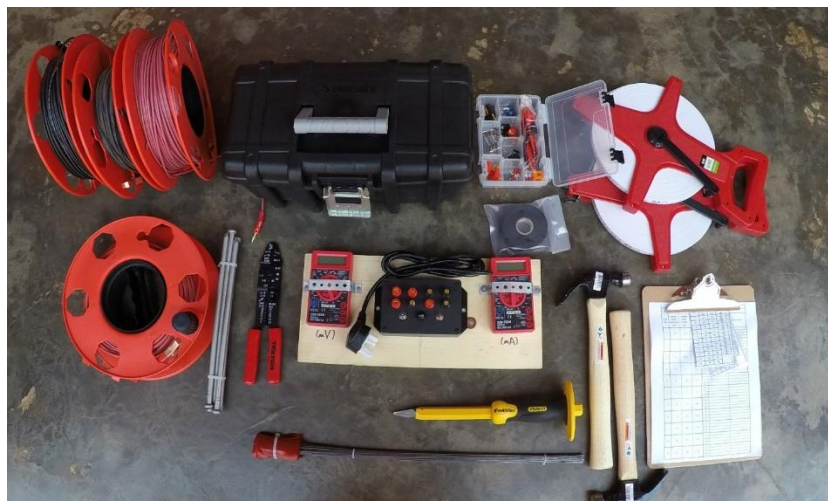

Figure 4: The Water4 resistivity toolkit consisting of control box, wire cable, spike electrodes, multimeters, measuring tapes, inverter and repair supplies.

## SUSTAINABLE GROUNDWATER DEVELOPMENT

### Groundwater Resources & Hydrogeology

Cameroon, DR Congo, Kenya, Uganda, Rwanda, Malawi, Zambia, Ghana, Ethiopia, Niger, Mali, and Sierra Leone. Table 1 lists all of the country partners and the number of wells drilled to date. An ambitious endeavor is underway to train these nationally led drilling teams to sustainably provide wells in 19 African nations. This involves reducing failure rates, reducing the price of boreholes, and generating

Country, region	Partner	Year Started	Number of wells
Togo	Eau Pour Le Togo	2010	330
Zambia	Water Access Zambia	2009	338
Cameroon	Okla Foundation	2016	(In Training)
DRC, Bunia	Shalom University Bunia	2014	42
DRC, Mbandaka	Disciples for Water	2014	23
DRC, Katanga	Water Works Katanga	2014	28
Kenya	Tak Water	2014	9
Uganda	Young Men Drillers	2013	104
Rwanda	Water Access Rwanda	2014	27
Malawi (Blantyre)	Water Zone	2015	21
Malawi (Lilongwe)	MOMS Drillers	2013	55
Ghana	Access Development Ghana and World Vision	2012	90
Ethiopia	Access Development Ethiopia and World Vision	2014	200
Niger	Access Development Niger	2015	60
Sierra Leone	Willamette International	2011	175
Mali	World Vision Mali	2013	110

local income for each team's continued operations through monetized and reticulating water systems.

Table 1: Water4 Country Partners and Total of Manually Drilled Wells as of 1 May 2016

In support of this drilling effort, Water4 has trained dozens of operators to use the inexpensive resistivity instrument to site wells. These teams determine the subsurface earth structure directly below a potential well location with the VES method outlined above. The VES teams work directly with the drilling teams, providing site selection based on their readings, local knowledge and the known capability of the tools and equipment the drillers possess. Each team performs at least two VES surveys at a proposed well location. The VES teams are part of a strong network that capitalizes on messaging apps to communicate among themselves and they improve their interpretive and site selection skills by sharing experiences and data from the different hydrogeology Water4 partners in other regions of Africa.

#### Main results and lessons learnt

Vertical electrical sounding methods have been used by Water4 teams to site more than 150 rural wells in Africa since 2014 and, in addition, have ruled out difficult or improbable drilling locations that would have wasted a drilling team's time and resources. Although the collective results from all of the teams are in the process of being completely assembled, all indications are that the method is highly effective in guiding well siting. VES records are now available from 64 wells drilled since 2015 from Tanzania, Kenya, Rwanda and Uganda. Results in Table 2 indicate that VES correctly predicted the outcome of 55 of these wells (86% accuracy). Of the sited wells, the two that were dry were due to the lack of texture clarity from resistivity-based readings failing to predict low permeability layers in the aquifer. The method is most reliable in areas where water is situated on top of a sizable impermeable structure such as compact clay or rock within 30 m from the surface. Table 2 shows that if the VES indicates a location is suitable for a well there is a high probability (96%) that the well will be successful. If the VES indicates a well site is not suitable there is still a 41% chance that a successful well will result.

SUSTAINABLE GROUNDWATER DEVELOPMENT

Groundwater Resources & Hydrogeology

Of 64 wells the predicted outcome was accurate for 55 of them (86% accurate). The Chi-square value of 24.4 with 1 degree of freedom (significance level less than 0.001%) indicates it is highly unlikely that the results in the table are random.

		WELL	
		Successful	Unsuccessful
VES	Positive	45 (Correct Prediction)	2 (False Positive)
	Negative	7 (False Negative)	10 (Correct Prediction)

Table 2: Accuracy of VES predictions

Stratigraphic resolution decreases as depth increases which can often mask significant permeable structures surrounded by less favorable lithology. In rapidly varying soil this becomes problematic until a baseline understanding can be created from exploratory drilling. For example VES signatures from dry sand can be misinterpreted as bedrock. The most problematic structure for VES interpretations is saturated sedimentary rock. These structures may have high weathering in places but we are unable to predict this because the apparent resistivity between the saturated sedimentary rock and decomposed layers are poorly expressed in the data. The same is true for saturated clay layers that might contain permeable water-bearing zones such as sand or gravel. If there is not a clear resistivity differential exploratory drilling will be needed. Water4 is experimenting with low-cost seismic technology to complement VES readings with additional seismic velocity data. Despite these difficulties the majority of the wells sited with VES provided adequate supply for the installed hand pumps. In comparison to drilling a dry well, the cost of the instrument is small. If it even prevents drilling one unsuccessful borehole, then the cost of the instrument is repaid.

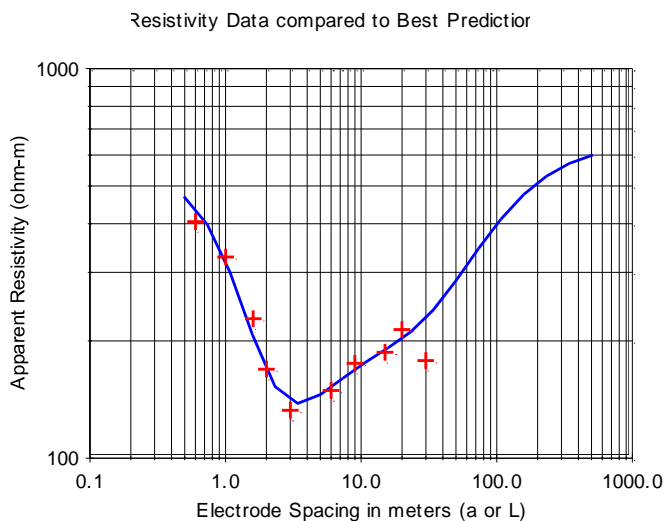

Figure 5: The resistivity VES data for Ngambi where a shallow aquifer 3 m deep was found near the village on top of the mountain. The yield of the well has remained constant at about 35 liters/min, satisfying the needs of the 30 families who share the well.

The time required to perform a VES survey, interpret the data and consult the global team is under 3 hours whereas a well takes several days to complete. Often the VES teams will assemble and use regional survey notes, latrine digger accounts and surface observations to aid in interpretation of the VES data. Many countries are now requiring that resistivity methods be used and reported to government officials

## SUSTAINABLE GROUNDWATER DEVELOPMENT

### Groundwater Resources & Hydrogeology

before drilling a well. Of countries where Water4 is working Kenya, Uganda, Rwanda and Sierra Leone require a VES survey before drilling and our inexpensive instrument satisfies this drilling requirement.

#### *Examples and Applications: More Accessible Wells*

In Rwanda, since starting VES surveys in May of 2015, the local social enterprise Water Access Rwanda was able to site 14 successful boreholes and locate more than 20 sites where future borehole drilling can be conducted. Before these surveys, drillers only attempted water wells in the valley despite the fact that most settlements are located in the high mountains in Rwanda. Since starting a resistivity team, Water Access Rwanda has been able to site 4 boreholes at altitudes of 1400-1600 m providing water wells at locations which would have not been considered previously by drillers. An example of the data showing the relationship of apparent resistivity to a-spacing for Ngambi in the district of Gakenke is in Figure 5. Here residents no longer have to walk down the mountain to access water because it is now readily available close to their houses.

#### *Examples and Applications: Avoiding Difficult Drilling Sites*

Furthermore, the drillers are advised, through VES, of areas of lower apparent resistivity to drill in. Areas containing hard soil increases drilling team expenses from broken parts, however VES interpretations guide drillers to avoid such areas. For example, a VES team conducted surveys in an area with rolling hills, subject to granite outcrops and hard rocks and advised the drilling team where to drill (Figure 6).

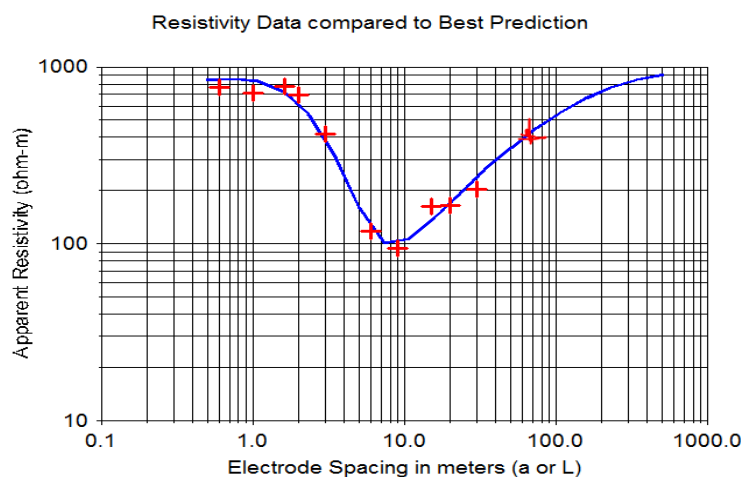

**Figure 6 (a)** This site was avoided due to the high resistivity, saving drilling expense of approximately \$3,000 (what it would have cost to drill through such rocks).

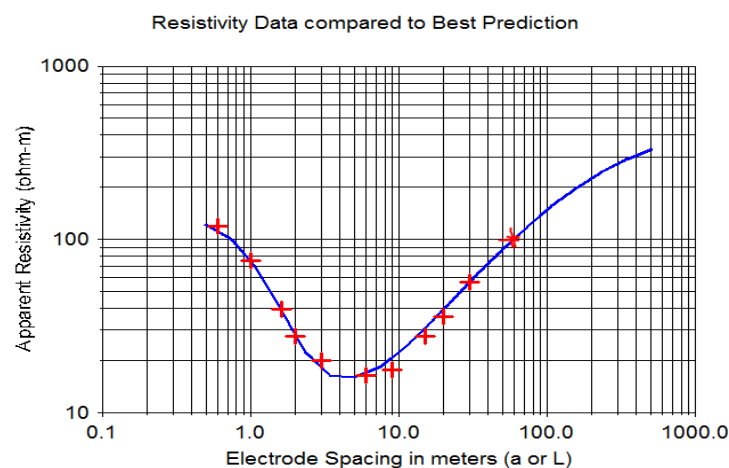

**Figure 6 (b)** This site was successfully drilled at 10 m and still provides clean water to the community.

#### *Examples and Applications: Reduced Drilling Expense*

SUSTAINABLE GROUNDWATER DEVELOPMENT

Groundwater Resources & Hydrogeology



Figure 7: Though the stones in this area can be discouraging, our VES team was able to determine that the layer was only 1 m thick so this Pygmy community in rural Rwanda now has

In Bunia, DR Congo, the local drilling team, Shalom Drillers provides wells for the residents and especially for the recently freed Pygmy population living deep in the rainforest (Figure 7). A well drilling team must travel more than 100 km over bad roads, often walking long distances up steep hills and crossing poorly constructed bridges. Traveling such a long distance and spending so many resources is wasteful and discouraging for drillers if the result is a dry hole. Now the drillers can send a recently trained VES team ahead to not only find sites with an aquifer but also to warn drillers of hard layers of granite occurring close to aquifers. Figure 8 illustrates several examples of VES taken in the same area.

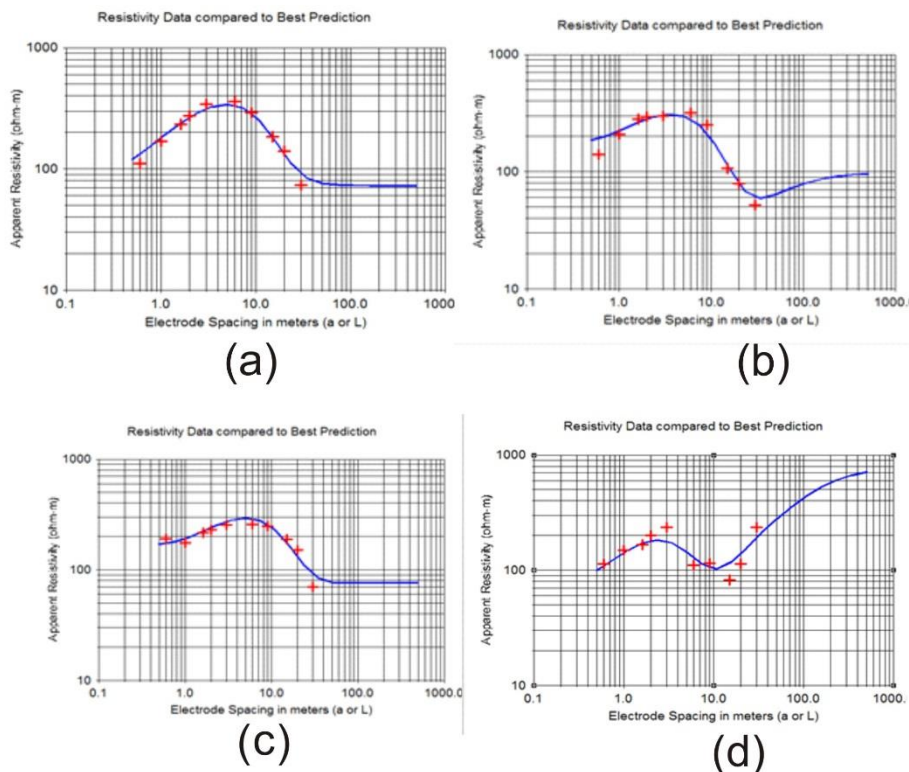

Figure 8: VES surveyors ruled out points (a) (b) and (c) in favor of (d) which shows a softer layer between 2 and 3 meters deep and a closer aquifer – predicted as the lowest resistivity layer – at only 12m of depth.

*Examples and Applications: Dissemination and Expertise*

These resistivity teams are spreading throughout Africa with teams training other teams to use the equipment. Now Rwanda, DR Congo and Togo each have two resistivity teams, and Uganda, Kenya, and Tan-

## SUSTAINABLE GROUNDWATER DEVELOPMENT

### Groundwater Resources & Hydrogeology

zania each have one team. These teams become very proficient in interpreting the raw resistivity data in their respective regions. Their expertise is multiplying through strategies to keep the teams in communication with one another (through WhatsApp groups) and regional coordination assured by French and English speaking coordinators. Training workshops and conferences are multinational allowing teams of VES surveyors to share insights about the use of the equipment and their own experiences and best-practice field methods.

#### *Discussion:*

Instrument improvements and additional inexpensive geophysical methods are now being investigated in the field and the laboratory. For example it is possible to use the resistivity instrument to make a horizontal electrical profile to determine lateral changes in lithology. For this type of survey the electrodes are fixed at a constant a-spacing, characteristic of the minimum depth of bedrock for a well in the region, and then moved laterally to record horizontal estimates of apparent resistivity. If this analysis indicates that an adequate aquifer depth is found then a vertical electrical sounding follows to verify the site as a good prospect for a successful well. To improve subsurface interpretation it is possible to use seismic refraction and induced polarization methods which provide additional lithologic properties helpful in untangling ambiguities in the VES data. Inexpensive seismic refraction methods (Clark et al., 2011; 2016) yield seismic wave velocities of rock layers. The laptop sound card and a geophone are the main components of this inexpensive instrument. The induced polarization method is similar to resistivity methods except readings of voltage are obtained after the current is turned off. The subsequent gradual decay in voltage is then tracked through time by rapidly recording many voltages. Results yield rock properties that are related to the electrical capacitance of subsurface layers. To take these readings it is necessary to incorporate an inexpensive computer (Arduino – about \$25) into the existing resistivity instrument. This computer controls the current reversals and also records 50 voltage and current readings each second so that apparent resistivity and induced polarization are determined simultaneously. The instrument is functioning now and is well within the \$250 design goal, but further improvement is necessary to insure it will operate reliably under field conditions (Clark et al., 2016).

#### **Conclusions and Recommendations**

It is well documented that geophysical instruments can greatly improve the success rate of drilling water wells in Africa. Our work indicates that even a very simple and inexpensive resistivity instrument that costs less than \$800, though limited in operational ease and depth of penetration (less than 35 m), is adequate for siting most rural wells that are hand-dug or manually drilled. African nationals can operate the instruments extremely well and are proficient in interpreting the data to site wells. The expertise these teams are acquiring through extensive field work is helping other teams to form and to be more effective. If even one dry well is avoided through use of the resistivity instrument, the cost of the instrument is repaid. Our desire is that others will continue to improve these simple instruments and that they will help alleviate water stress in rural communities across Africa by providing safe water sources near communities through knowledge of underground layers and aquifer depth.

#### **Acknowledgements**

We thank Randy Jones and Ray McKee for their introduction to Water4 of the Wheaton College developed technology and software. They have undertaken hardware fabrication and improvement of the VES equipment and continue to supply funds to provide instruments, training, and active support for the resistivity teams in Sub Saharan Africa. They have been essential in the dissemination of the equipment and in support of the teams. We also thank the team of 4 VES leaders working with Water4 to monitor, evaluate and improve the water4 teams of operators; namely Olive Mukesharugo, Justine Olweny, David Afaya and Roderick Amula. We wish to thank Wheaton College for sabbatical leave support, the Wheaton College Alumni Association for support both in the development of the resistivity devices and for funding field work as the instruments were developed and refined, and the Wheaton College Global and Experiential Learning center for conference support.

#### **References**

## SUSTAINABLE GROUNDWATER DEVELOPMENT

### Groundwater Resources & Hydrogeology

- Barker, R.D., White C.C., and Houston, J.F.T., (1992) Borehole siting in an African accelerated drought relief project, *in* Wright, E.P., and Burgess, W.G., eds., Hydrogeology of Crystalline Basement Aquifers in Africa: Geological Society, London, Special Publication 66, p. 183-201, [doi:10.1144/GSL.SP.1992.066.01.09](https://doi.org/10.1144/GSL.SP.1992.066.01.09)
- Clark, J. A. and Page, R., (2011), Inexpensive geophysical instruments supporting groundwater exploration in developing nations: Journal of Water Resource and Protection, v. 3, no. 10, p. 768-780, [doi:10.4236/jwarp.2011.310087](https://doi.org/10.4236/jwarp.2011.310087)
- Clark, J.A., Page, R.T., Franklin, R., Miller, N.M., and Morken, M.O., (2016), Appropriate geophysics technology: Inexpensive instruments for water exploration at a local level in developing nations, *in* Wessel, G.R., and Greenberg, J.K., eds., Geoscience for the Public Good and Global Development: Toward a Sustainable Future: Geological Society of America Special Paper 520, p. 171–181, [doi:10.1130/2016.2520\(16\)](https://doi.org/10.1130/2016.2520(16)).
- Kirsch, R. ed., (2006), Groundwater Geophysics: a tool for hydrogeology: New York, Springer, 493 p.
- MacDonald, A., Davies, J., Calow, R. and Chilton, J (2005) Developing Groundwater: a guide for rural Water Supply, Practical Action Publishing 358 p.
- QGIS Development Team, (2014) QGIS Geographic Information System. Open Source Geospatial Foundation Project. <http://qgis.osgeo.org>
- Rubin, Y., and Hubbard, S.S., eds., (2006), Hydrogeophysics: Dordrecht, The Netherlands, Springer, p. 129-156.
- SAGA, (2015) SAGA: system of automated geoscientific analysis, <http://www.saga-gis.org>



SUSTAINABLE GROUNDWATER DEVELOPMENT

Groundwater Resources & Hydrogeology

# Gestion quantitative et qualitative des ressources en eau dans la plaine alluviale de Karfiguéla à l'aide d'un SIG : Etude de la recharge induite de la nappe et sa vulnérabilité à la pollution

Type: Article long

## Auteurs

**SIMBORO Aly**, Etudiant à la Fondation 2iE, Burkina Faso, [simboro05@hotmail.com](mailto:simboro05@hotmail.com), +226 70257258/71619142

## RESUME

*La présente étude a été menée sur la nappe alluviale de Karfiguéla au Burkina Faso. Cette nappe est de plus en plus sollicitée pour les besoins de l'agriculture irriguée. Notre travail a pour objectif principal de proposer une gestion quantitative et qualitative des ressources en eaux souterraines dans la plaine.*

*Ainsi grâce à ArcGIS, qui est un outil de SIG, nous avons caractérisé la recharge induite et évalué la vulnérabilité à la pollution de la nappe superficielle. La superposition des cartes de facteurs influençant la recharge induite a permis d'identifier les zones favorables à la recharge induite qui sont généralement localisées par les zones de forte perméabilité du sol.*

*L'utilisation des méthodes DRASTIC, GOD et SI pour la cartographie de la vulnérabilité à la pollution montre que la nappe de Karfiguéla court un risque élevée de pollution du fait de la nature hydrogéologique de la nappe et aussi de l'importance des activités agricoles sur presque l'ensemble de l'étendue. Ce risque est encore plus élevé dans les zones de fortes perméabilités.*

*Les zones de recharge induite sont celles qui présentent un risque très élevé de pollution.*

*La réalisation d'infrastructures telles que des bassins de rétention et d'infiltration permettrait d'augmenter la quantité d'eau rechargeant la nappe. Aussi une délimitation de périmètres de protection autour de ces zones contrôlant les activités agricoles permettrait d'assurer une qualité acceptable de l'eau.*

## INTRODUCTION

L'eau est une ressource indispensable à la survie de tous les êtres vivants, et à la réalisation de nombreuses activités fondamentales des sociétés humaines. Bien que l'eau ne soit pas toujours le principal facteur restrictif, elle demeure tout de même un élément déterminant pour stimuler la production agricole. La gestion l'eau agricole constitue donc est un puissant moyen de lutte contre la pauvreté en milieu rural.

Le Burkina Faso est un pays agricole à 80%, l'agriculture constitue la principale source de revenus pour près de 86% de la population active, et procure plus de 50% des recettes totales à l'exportation (source : MAHRH). Cette agriculture représente 64% de la demande globale en eau au Burkina Faso et une grande partie de cette demande est satisfaite à partir des eaux de surface pourtant menacées par le tarissement rapide en saison sèche (DGH, 2001). Ce facteur amène beaucoup de cultivateurs à se tourner vers les eaux souterraines qui deviennent de plus en plus exploitées. Les plaines les plus irriguées sont localisées dans les régions des Hauts-Bassins, des Cascades et du Centre Ouest. Au niveau de la plaine alluviale de Karfiguéla dans la région des Cascades, la pluviométrie est relativement bonne et les ressources en eau sont facilement mobilisables. Aussi, on assiste à un développement des activités agricoles et l'extension de périmètres irrigués accompagnés par une surexploitation de la nappe phréatique. Face à cette situation, un programme pour la gestion durable des ressources en eaux souterraines dans cette zone est devenu indispensable.

## CONTEXTE ET OBJECTIFS

Le Programme d'Appui au développement de l'Irrigation(PADI), à travers son Projet PADI BF-101 (Gestion Durable des Eaux Souterraines pour l'Agriculture Irriguée), se fondant sur les orientations de la

## **SUSTAINABLE GROUNDWATER DEVELOPMENT**

### **Groundwater Resources & Hydrogeology**

politique nationale de développement durable de l'agriculture irriguée, nous a confié cette étude portant sur la gestion qualitative et quantitative des ressources en eau souterraine dans la plaine alluviale de Karfiguéla à l'aide d'un SIG.

L'objectif général est d'étudier la recharge induite de la nappe superficielle de Karfiguéla et d'évaluer sa vulnérabilité à la pollution. Plus spécifiquement notre travail consistera à :

- Identifier les zones favorables à la recharge induite
- Evaluer la vulnérabilité et le risque de pollution à travers différentes méthodes de cartographie.
- Proposer un système de gestion durable de la ressource en eau souterraine

## **METHODOLOGIE**

### **Données et matériels**

#### **Données**

Dans le cadre de cette étude, plusieurs types de données ont été utilisés. Il s'agit :

- Des données de la piézométrie et la qualité des eaux issues de la campagne de suivi piézométrique et qualité des eaux réalisée par le PADI-BF 101 (2013 - 2015) dans la région.
- Des données de conductivité hydraulique (BETAN, 2013)
- Des coupes lithologiques des piézomètres du PADI- BF 101
- Des données cartographiques : la carte d'occupation du sol, carte hydrographique.

#### **Matériels**

Le matériel utilisé est essentiellement composé de:

- Sondes piézométriques à double signalisation
- Sondes Diver: Sonde à capteur de pression pour une mesure continue du niveau statique.

Outre le matériel terrain, nous avons utilisé plusieurs logiciels techniques à savoir:

- Microsoft Office (Access et Excel) pour le prétraitement des données
- Surfer 9 et ArcGIS 9.2 pour l'établissement des différentes cartes basées sur la représentation

#### **SIG et leur apport**

Le concept de SIG :Système d'Informations Géographiques désigne un système de rassemblement, de stockage, de manipulation, d'analyse et d'affichage des données localisées dans l'espace et attributaires d'origines différentes et leur visualisation dans les modèles de décision afin de résoudre les problèmes complexes d'aménagement et de gestion" (ESRI, 2002).

Les SIG permettent d'inspirer des approches globales en matière de gestion des ressources en eaux qui pourraient faciliter le développement de solutions aux problèmes de surexploitation et de dégradation de la qualité des eaux souterraines (Habib Smida et al., 2009).

Le point fort des SIG réside particulièrement dans leur capacité de relier les objets géographiques à leurs attributs thématiques. Cette dernière fonction est très utile en ce qui concerne le calcul et l'établissement des cartes de recharge et de vulnérabilité à la pollution des eaux souterraines.

Dans le cadre de cette étude, on a utilisé le logiciel ArcGIS développé par ESRI. Ce logiciel doté de fonctions et outils mathématiques puissants, permet de travailler en systèmes vectoriels et matriciels.

#### **Etude de la recharge induite de l'aquifère alluvial de Karfiguéla**

## SUSTAINABLE GROUNDWATER DEVELOPMENT

### Groundwater Resources & Hydrogeology

#### Notion de recharge induite

La recharge ou l'alimentation d'une nappe peut être définie comme étant l'« apport d'eau externe, de toutes origines, à un aquifère » (Ndiaye, 2008). Il existe quatre (4) principaux modes de recharge :

- La recharge naturelle ou directe qui se fait par l'infiltration des précipitations
- La recharge latérale et/ou verticale inter aquifère
- La recharge induite qui se fait à partir des eaux de surface
- La recharge artificielle utilisant les techniques telles que les injections.

Dans le cadre de cette étude nous nous intéresserons à la recharge induite à travers l'identification des zones favorables à cette recharge.

Ainsi les paramètres tels que le niveau de la nappe phréatique, les données géologiques, données hydro-géomorphologiques jouent un rôle important dans le choix du site.

#### Facteurs de la recharge induite

- **Géomorphologie : topographie**

La détermination de la forme des reliefs est très utile pour déterminer le sens d'écoulement des eaux de surface et pour rechercher des sites de réservoirs de rétention et de stockage des eaux de surface. La topographie à travers la pente a un contrôle direct sur le ruissellement et l'infiltration des eaux. Les zones basses à faible pente permettent une accumulation des eaux de surfaces et leur infiltration jusqu'à la nappe.

- **Hydrographie**

Il s'agit tout d'abord d'analyser toutes les sources en eau possibles pour la recharge et de définir leur répartition en débit dans le temps et dans l'espace ainsi que le meilleur moyen de les diriger efficacement sur le site ; par conséquent, s'assurer de disponibilités adéquates en quantité et qualité au moment voulu.

- **Sol : perméabilité**

Les caractéristiques des dépôts de surface sont à considérer. Par exemple, plus la texture du sol sera grossière plus le taux d'infiltration sera élevé. Outre la texture, intervient le paramètre perméabilité. Une carte de perméabilité a été élaborée à partir de la carte des sols en attribuant un coefficient de perméabilité pour chaque type de sol en zone semi-aride.

SUSTAINABLE GROUNDWATER DEVELOPMENT

Groundwater Resources & Hydrogeology

Type lithologique	Perméabilité (cm/s)
Gravier	$10^{-1} < k < 10^2$
Sable	$10^{-3} < k < 10^{-1}$
Limon et sable argileux	$10^{-7} < k < 10^{-3}$
Argile	$10^{-11} < k < 10^{-8}$
Roches non fissurées	$10^{-10} < k < 10^{-8}$
Dépôts grossiers	$10^1 < k < 10^2$
Graviers fins	$10^{-1} < k < 10^1$
Grès	$10^{-3} < k < 10^{-1}$
Calcaires	$10^{-5} < k < 10^{-3}$
Grès + marnes + calcaires	$10^{-7} < k < 10^{-5}$
Marnes + calcaires	$10^{-9} < k < 10^{-7}$
Marnes, gypses, sol de <i>sebkha</i>	$k < 10^{-9}$

Tableau 1 : Tableau de perméabilités des sols SMIDA, 2006

- **La piézométrie**

Le niveau piézométrique peut être défini comme étant le niveau de la colonne d'eau qui équilibre la pression hydrostatique régnant au bas de cette même colonne. En pratique, elle représente en nappe libre, la cote de la surface libre de l'eau.

La carte piézométrique est une véritable topographie de la nappe qui permet de déterminer son sens d'écoulement et est descriptive des zones de recharge induites. Les zones de dômes piézométriques représentent les zones d'entrée des eaux de surface.

Les données des campagnes piézométriques 2014 ont fait l'objet d'une interpolation manuelle suivi d'une numérisation pour obtenir une première carte piézométrique, cette carte est ensuite utilisée pour produire des nouvelles données. Ces nouvelles données sont introduites dans l'environnement Surfer pour élaborer une carte piézométrique.

Cartographie des zones de recharge induite

Cette étape consiste en la fusion et en la superposition des données ci-dessus énumérées. Le but est d'obtenir de nouvelles informations grâce à ces données, informations qui se traduisent par la représentation des divers résultats sur un seul et un même support afin de pouvoir effectuer une analyse plus globale.

À partir de la base de données de PADI BF-101 et grâce à ArcGIS, des cartes thématiques ont été élaborées. Ces cartes ont été ensuite superposées et/ou ont fait l'objet d'analyse permettant ainsi de dresser une carte de recharge induite et d'identifier les zones les plus favorables.

SUSTAINABLE GROUNDWATER DEVELOPMENT

Groundwater Resources & Hydrogeology

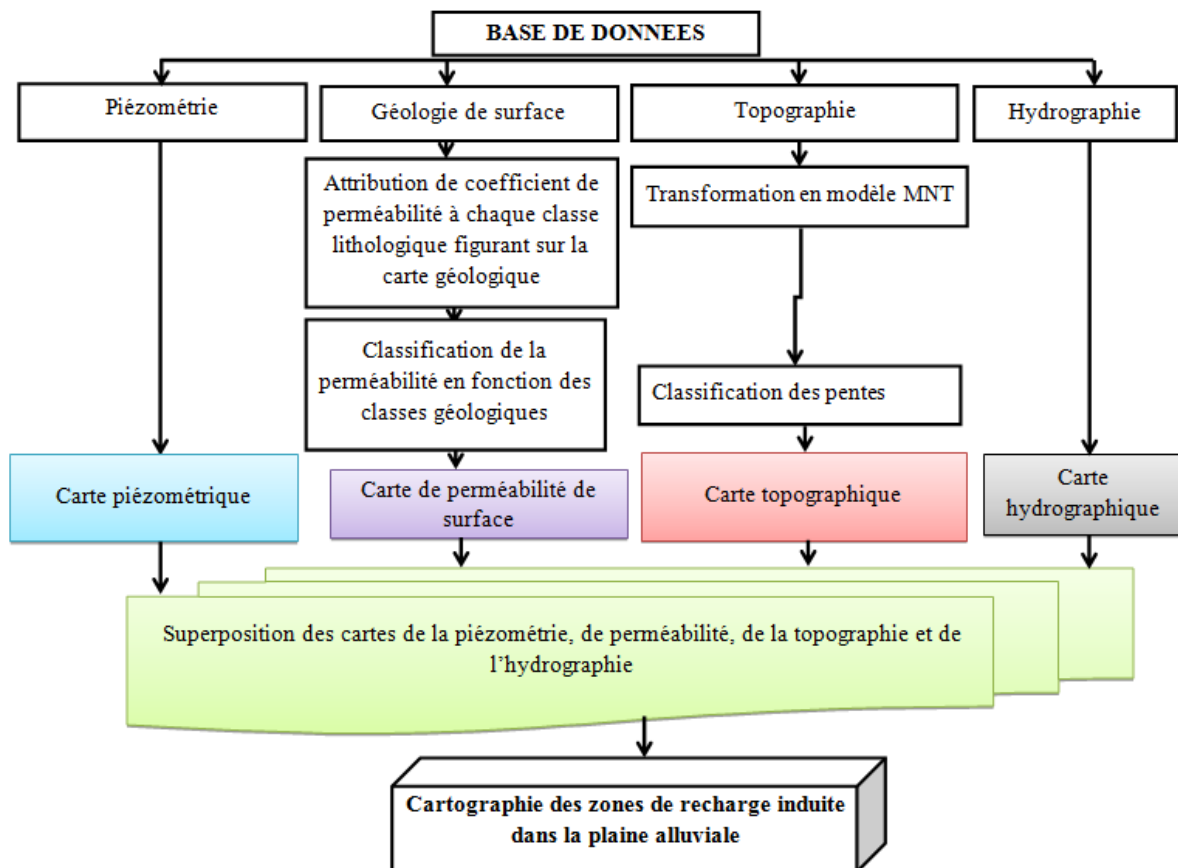

Figure 10: Organigramme des étapes de réalisation de la carte de la recharge induite

**Evaluation de la vulnérabilité à la pollution**

**Notion de vulnérabilité à la pollution**

La vulnérabilité est le « défaut de protection ou de défense naturelle de l'eau souterraine contre des menaces de pollution, en fonction des conditions hydrogéologiques locales » (Comité National Français des Sciences Hydrologiques).

Autrement dit, la vulnérabilité est le terme utilisé pour représenter les caractéristiques du milieu naturel qui déterminent la sensibilité des eaux souterraines à la pollution.

Dans la littérature, les différentes études de vulnérabilité font généralement la distinction entre deux (02) notions d'évaluation de la vulnérabilité :

- **La vulnérabilité intrinsèque** : qui considère les conditions physiques naturelles de l'aquifère, La vulnérabilité intrinsèque est indépendante du polluant.
- **La vulnérabilité spécifique**, qui fait intervenir non seulement les paramètres naturels, mais également les propriétés du contaminant, des activités humaines ou même des populations à risque,

**Evaluation des paramètres de vulnérabilité**

Plusieurs paramètres interviennent dans le transfert de pollution à partir de la surface du sol:

- **Le niveau statique ou profondeur de la nappe**

C'est la distance verticale de la surface topographique à la surface piézométrique. C'est un paramètre important qui détermine l'épaisseur des matériaux à travers lesquels un contaminant peut circuler avant d'atteindre le plan d'eau (Ebtissem Riahi CHANDOUL et al, 2008).

## SUSTAINABLE GROUNDWATER DEVELOPMENT

### Groundwater Resources & Hydrogeology

- **La recharge efficace**

La recharge efficace est la quantité totale d’eau qui atteint la surface piézométrique et est l’agent vecteur des contaminants. Généralement plus la recharge est importante, plus la possibilité de contaminer la nappe est élevée (Ebtissem Riahi et al. In Samir Bouaziz et al. Ben.,2008).

Les études de DAO, 2015 (en utilisant la méthode du bilan de THORNTHWAITE et la méthode des fluctuations piézométriques) ont permis de quantifier cette recharge sur la plaine alluviale de Karfiguéla.

- **Les matériaux d’aquifère :**

Un aquifère est un réservoir d’eau souterraine. Les matériaux de l’aquifère déterminent la mobilité d’un éventuel contaminant dans cet aquifère. HALADOU (2013) a caractérisé les matériaux de la plaine par une combinaison de géophysique et d’analyse granulométrique établissant ainsi les coupes lithologiques des piézomètres.

- **Le type de Sol :**

Le type de sol est la portion au-dessus de la zone non saturée. Le sol peut réduire, retarder ou accélérer le processus de propagation du polluant vers l’aquifère. Ce paramètre correspond approximativement au premier dépôt à partir de la surface topographique.

- **La topographie:**

La topographie indique si un polluant fuira ou restera à la surface du sol pour s’infiltrer dans la nappe (Lynchez et al, 1994). La couverture topographique est obtenue par interpolation des altitudes DGPS des piézomètres (HALADOU 2013).

- **La zone non saturée :**

La zone non saturée ou zone vadose, représente la portion de terrain au-dessus du niveau de l’eau. La texture de cette zone détermine le temps de transfert du contaminant dans l’aquifère.

Les coupes lithologiques des piézomètres ont été utilisées pour l’élaboration de ce paramètre.

- **La conductivité hydraulique :**

Elle décrit la vitesse à laquelle l’eau se déplace à travers un aquifère (YANOOGO, 2008) et contrôle ainsi la vitesse de propagation du polluant dans l’aquifère : plus la conductivité est élevée, plus le transfert du polluant est rapide.

Les travaux de BETAN 2013, à travers la méthode d’essai de choc hydraulique dite « slug test» ont permis la détermination des valeurs de conductivité hydraulique.

- **L’occupation du sol**

Elle traduit les activités anthropiques et/ou l’occupation naturelle des terres (végétation). L’occupation des sols informe sur le potentiel d’émission d’un polluant à la surface du sol.

Les informations sur l’occupation du sol de la plaine de Karfiguéla proviennent de la Base de Données d’Occupation des Terres (BDOT 2002) disponibles à l’IGB.

### Méthodes de cartographie de la vulnérabilité à la pollution

Plusieurs techniques permettent l’évaluation de la vulnérabilité des aquifères.

Pour l’étude de la vulnérabilité les méthodes DRASTIC, GOD et SI ont été utilisées

### La méthode DRASTIC

## SUSTAINABLE GROUNDWATER DEVELOPMENT

### Groundwater Resources & Hydrogeology

La méthode DRASTIC, développée en 1987 aux Etats-Unis par la *National Water Well Association* (Aller et al. 1987) pour le compte de l'Agence américaine de la Protection de l'Environnement (US EPA), est une méthode standardisée d'évaluation et de cartographie de la vulnérabilité des eaux souterraines indépendamment du type de polluant.

Elle repose sur ces quatre (04) hypothèses (Kouamé et al, 2008) :

- La source de contamination potentielle est située à la surface du sol ;
- Les contaminants sont entraînés depuis la surface du sol jusqu'à l'aquifère par infiltration ;
- Les contaminants à la même mobilité que l'eau souterraine ;
- Le type de contaminant ne se dégrade pas

La méthode DRASTIC prend en compte la majeure partie des facteurs hydrogéologiques qui affectent et contrôlent l'écoulement des eaux souterraines (Mohamed, 2001). Ces paramètres au nombre de sept 7 sont :

**D** : (Depth to groundwater) Profondeur de la nappe

**R** : Recharge nette

**A** : (Aquifer media) nature lithologique de l'Aquifère

**S** : (Soil media) type de Sol :

**T** : (Topography) Topographie des terrains

**I** : (Impact of vadose zone) Impact de la zone non saturée

**C** : (Conductivity) Conductivité Hydraulique de la zone saturée

L'importance relative de chaque paramètre est évaluée par un poids fixe, variant entre une valeur de 5 pour les facteurs les plus significatifs et une valeur de 1 pour les facteurs qui le sont moins.

Chaque paramètre se voit attribuer une cote variant entre 1 et 10 en fonction des conditions locales ; les conditions de moindre vulnérabilité procurent des cotes faibles tandis que celles qui l'augmentent procurent des cotes élevées.

Le tableau ci-dessous présente les poids et cotes préconisés pour l'évolution des sept paramètres :

Paramètres	Poids	Classes	Cotes
D: distance à la nappe ou épaisseur de la zone non saturée (en mètres)	5	0 – 1.5	10
		1.5 – 4.5	9
		4.5 – 9	7
		9 – 15	5
		15 – 23	3
		23 – 30	2
		> 30	1
R: recharge ou pluie efficace	4	0 – 50	1
		50 – 100	3
		100 – 175	6
		175 – 225	8
		> 225	9
A: lithologique de l'aquifère	3	Massive shale	2
		Roches ignées ou métamorphiques	3
		Roches ignées ou métamorphiques altérées	4
		Calcaire massif	8
		Grès massif	6

SUSTAINABLE GROUNDWATER DEVELOPMENT

Groundwater Resources & Hydrogeology

Paramètres	Poids	Classes	Cotes
		Sable et gravier	8
		Basalte	9
		Calcaire Karstique	10
S: nature du sol	2	Mince ou absent	10
		Graviers	10
		Sables	9
		Limons sableux	6
		Limons	4
		Limons siliceux	3
		Argiles	1
T: topographie des terrains exprimée par la pente (en %)	1	0 à 2	10
		2 à 6	9
		6 à 12	5
		12 à 18	3
		> 18	1
I: nature de la zone non saturée	5	Silt et argile	3
		Shale ou Calcaire	3
		Grès	6
		Sable et gravier avec passage silt et argile	6
		Sable et gravier	8
		Basalte	9
		Calcaire Karstique	10
C: perméabilité (m/s)	3	$1,5 \cdot 10^{-7} - 5 \cdot 10^{-5}$	1
		$5 \cdot 10^{-5} - 15 \cdot 10^{-5}$	2
		$15 \cdot 10^{-5} - 33 \cdot 10^{-5}$	4
		$33 \cdot 10^{-5} - 5 \cdot 10^{-4}$	6
		$5 \cdot 10^{-4} - 9,5 \cdot 10^{-4}$	8
		$> 9,5 \cdot 10^{-4}$	10

Tableau 2 : Cotes et Poids DRASTIC des paramètres de la vulnérabilité

La vulnérabilité est évaluée par l'indice DRASTIC qui est obtenu en multipliant la cote de chaque paramètre par son poids relatif et en faisant la somme de ces produits:

$$ID = (D_r D_w) + (R_r R_w) + (A_r A_w) + (S_r S_w) + (T_r T_w) + (I_r I_w) + (C_r C_w)$$

Avec **r** pour Rating (cote) et **w** pour weight (poids).

Après le calcul de l'indice, on fait correspondre des classes de vulnérabilité aux différentes plages d'indices DRASTIC calculés.

Vulnérabilité	Indice DRASTIC
Très faible	23 à 80



SUSTAINABLE GROUNDWATER DEVELOPMENT

Groundwater Resources & Hydrogeology

Faible	80 à 100
Moyenne	100 à 140
Forte	140 à 180
Très élevée	180 à 226

Tableau 3 : Classification des indices de vulnérabilité DRASTIC (Aller et al., 1987)

L'organigramme ci-dessous résume les étapes de réalisation de la carte de vulnérabilité selon la méthode DRASTIC:

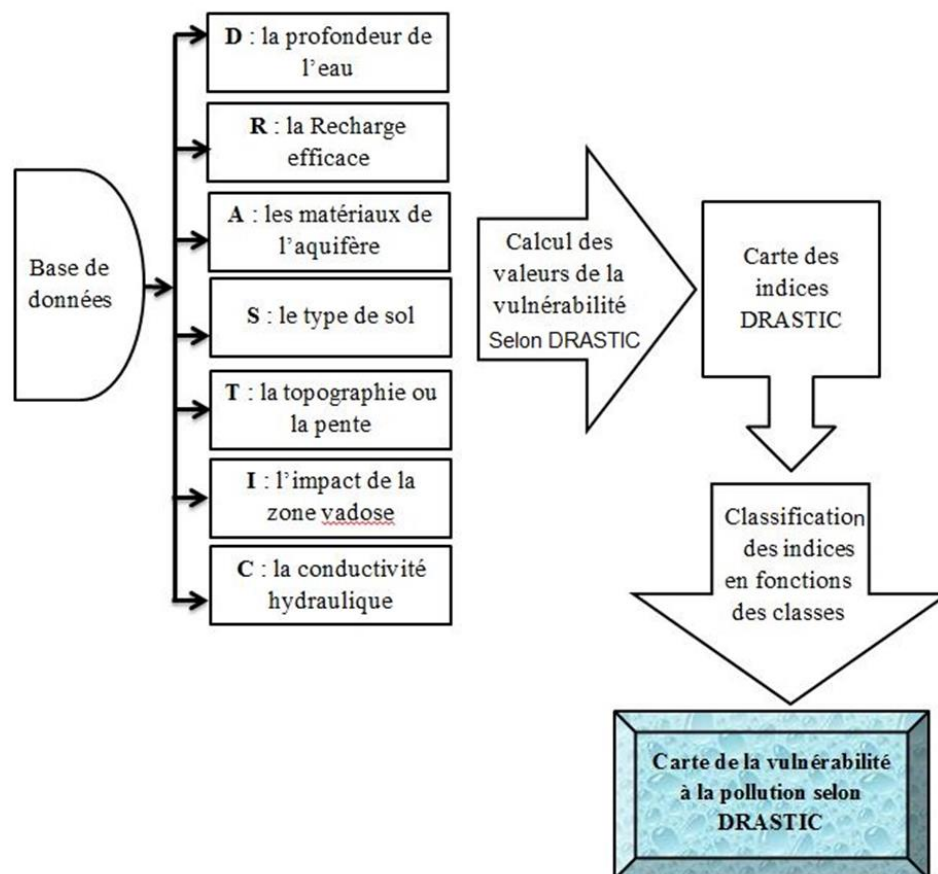

Figure 11: Organigramme de la cartographie de vulnérabilité par la méthode DRASTIC

**Méthode GOD**

La méthode GOD, conçue en Angleterre en 1987 par Poster (Murat et al., 2000), nécessite moins de paramètres que DRASTIC.

Elle permet de réaliser une estimation rapide de la vulnérabilité d'un aquifère (Bézelgues et al., 2002) à partir des trois paramètres de vulnérabilité ci-dessous:

- G** : (Groundwater occurrence) type de nappe en fonction de son degré de confinement
- O** : (Overall aquifer class) lithologie de la Zone non saturée
- D** : (Depth to groundwater) Profondeur de la nappe

Les notes attribuées aux classes des différents paramètres sont inférieures ou égales à 1.

L'indice de vulnérabilité GOD (IGOD) est obtenu par la multiplication des cotes de chacun des trois paramètres (Murat et al., 2000) selon la formule:  $IGOD = G_n \times O_n \times D_n$

Paramètres	Classes	Cotes
------------	---------	-------

SUSTAINABLE GROUNDWATER DEVELOPMENT

Groundwater Resources & Hydrogeology

<b>G</b> : Type d'aquifère	Artésien	0,1
	Confiné	0,2
	Semi-confiné	0,3
	Libre avec couverture	0,4 – 0,6
	Libre	0,7–1
<b>O</b> : Lithologie de la zone non saturée	Sol résiduel	0,4
	Limon alluvial, loess, calcaire fin	0,5
	Sable éolien, siltite, roches ignées ou métamorphiques fracturées	0,6
	Sable et gravier, grès	0,7
	Gravier (colluvion)	0,8
	Calcaire	0,9
	Calcaire fracturée ou karstique	1
<b>D</b> : Profondeur de la nappe(en mètres)	0 – 1.5	1
	1.5 – 4.5	0,9
	4.5 – 9	0,8
	9.0 – 15.0	0,7
	15 – 23	0,6
	23 – 30	0,4
	> 30	0,4

Tableau 4 : Poids GOD des paramètres de la vulnérabilité

La classification de la carte des indices GOD en tenant compte de la vulnérabilité permet l'élaboration de la carte de vulnérabilité à la pollution de la nappe de Karfiguéla

Classe GOD	Intervalle
Vulnérabilité très faible	0 - 0,1
Vulnérabilité faible	0,1 - 0,3
Vulnérabilité modéré	0,3 - 0,5
Vulnérabilité élevée	0,5 - 0,7
Vulnérabilité extrême	0,7 - 1

Tableau 5 : Classification des indices de vulnérabilité GOD (Murat et al., 2003)

Les différentes étapes de réalisation de la carte de vulnérabilité selon la méthode GOD sont résumées dans l'organigramme ci-dessous :

SUSTAINABLE GROUNDWATER DEVELOPMENT

Groundwater Resources & Hydrogeology

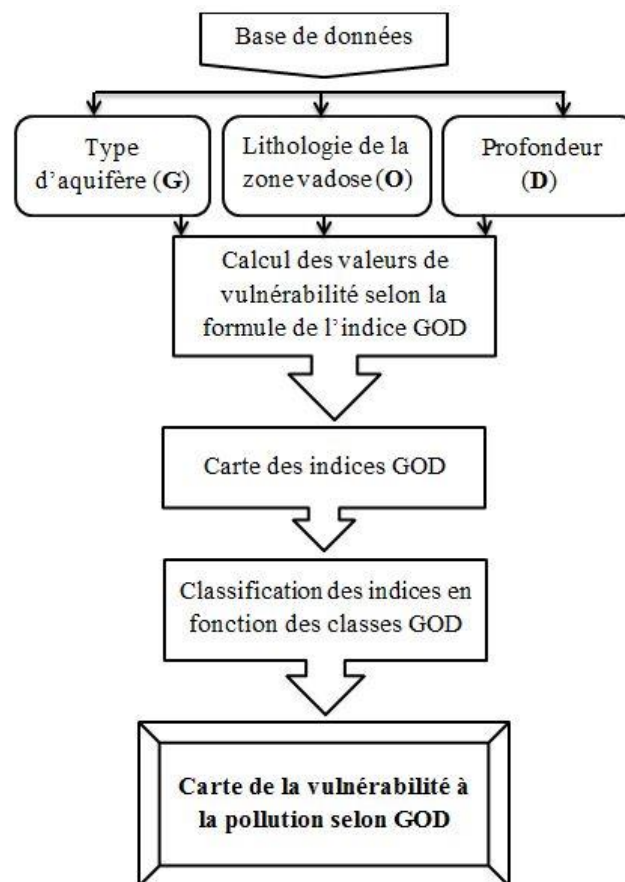

Figure 12: Organigramme de la cartographie de vulnérabilité à partir de la méthode GOD

**Méthode SI**

La méthode d'indice de susceptibilité (SI) est une méthode de vulnérabilité verticale spécifique, développée au Portugal par Ribeiro (2000), qui prend en compte les polluants d'origine agricole notamment les nitrates et les pesticides.

Elle utilise cinq paramètres :

**D** : (Depth to groundwater) Profondeur de la nappe

**R** : Recharge nette

**A** : (Aquifer media) nature lithologique de l'Aquifère

**T** : (Topography) Topographie des terrains

**OS** : (Land use) Occupation du sol.

L'élaboration de la carte de vulnérabilité, est effectuée par le calcul de l'indice de vulnérabilité (ISI) donnée par la formule:

$$ISI = D_c \times D_p + R_c \times R_p + A_c \times A_p + T_c \times T_p + O_c \times O_p$$

Où les indices c et p désignent respectivement la cote et le poids du paramètre.

Dans la méthode SI, les quatre premiers paramètres sont identiques à celle de la méthode DRASTIC en multipliant les cotes par 10.

Le nouveau paramètre Occupation des sols a une cote variant de 0 à 100, allant du moins vulnérable au plus vulnérable, est attribuée à chaque classe d'occupation des sols.

SUSTAINABLE GROUNDWATER DEVELOPMENT

Groundwater Resources & Hydrogeology

Les poids attribués aux paramètres SI varient de 0 à 1 selon l'importance du paramètre dans la vulnérabilité

Paramètres	Poids	Classes	Cotes
D: Profondeur de la nappe (en mètres)	0,186	0 – 1.5	100
		1.5 – 4.5	90
		4.5 - 9	70
		9.0 – 15.0	50
		15 - 23	30
		23 - 30	20
		> 30	10
R: recharge (en mm/an)	0,212	0 – 50	10
		50 - 100	30
		100 - 175	60
		175 - 225	80
		> 225	90
A: lithologie de l'aquifère	0,259	Massive shale	20
		Roches ignées ou métamorphiques	30
		Roches ignées ou métamorphiques altérées	40
		Calcaire massif	80
		Grès massif	60
		Sable et gravier	80
		Basalte	90
		Calcaire Karstique	100
T: topographie des terrains exprimée par la pente (en degré)	0,121	0 à 2	100
		2 à 6	90
		6 à 12	50
		12 à 18	30
		> 18	10
OS: Occupation des sols	0,222	Décharge industrielle, décharge d'ordures, mines	100
		Périmètre irrigués, rizière, cultures annuelles irrigués et non irrigués	90
		Carrière, chantier naval	80
		Zones artificielles couvertes, zones vertes, zones urbaines continues	75
		Cultures permanentes (vignes, verges, oli- vier, etc...)	70
		Zones urbaines discontinues	70
		Pâturages et zones agro-forestières	50

SUSTAINABLE GROUNDWATER DEVELOPMENT

Groundwater Resources & Hydrogeology

	Milieux aquatiques	50
	Forêts et zones semi-naturelles	0

Tableau 6 : Poids et Cotes SI des paramètres de vulnérabilité

Les indices de susceptibilité calculés représentent le niveau de risque de la vulnérabilité de l'aquifère. Ce risque prend une valeur qui est inférieure à 45 et une valeur maximale de 100. Après le calcul de l'indice de susceptibilité, le degré de vulnérabilité se définit suivant le tableau ci-dessous:

Degré de vulnérabilité	Indice de vulnérabilité
Faible	< 45
Moyen	45 - 64
Elevé	65 - 84
Très élevé	85 - 100

Tableau 7 : Classification des indices de vulnérabilité SI (Ribeiro,2000)

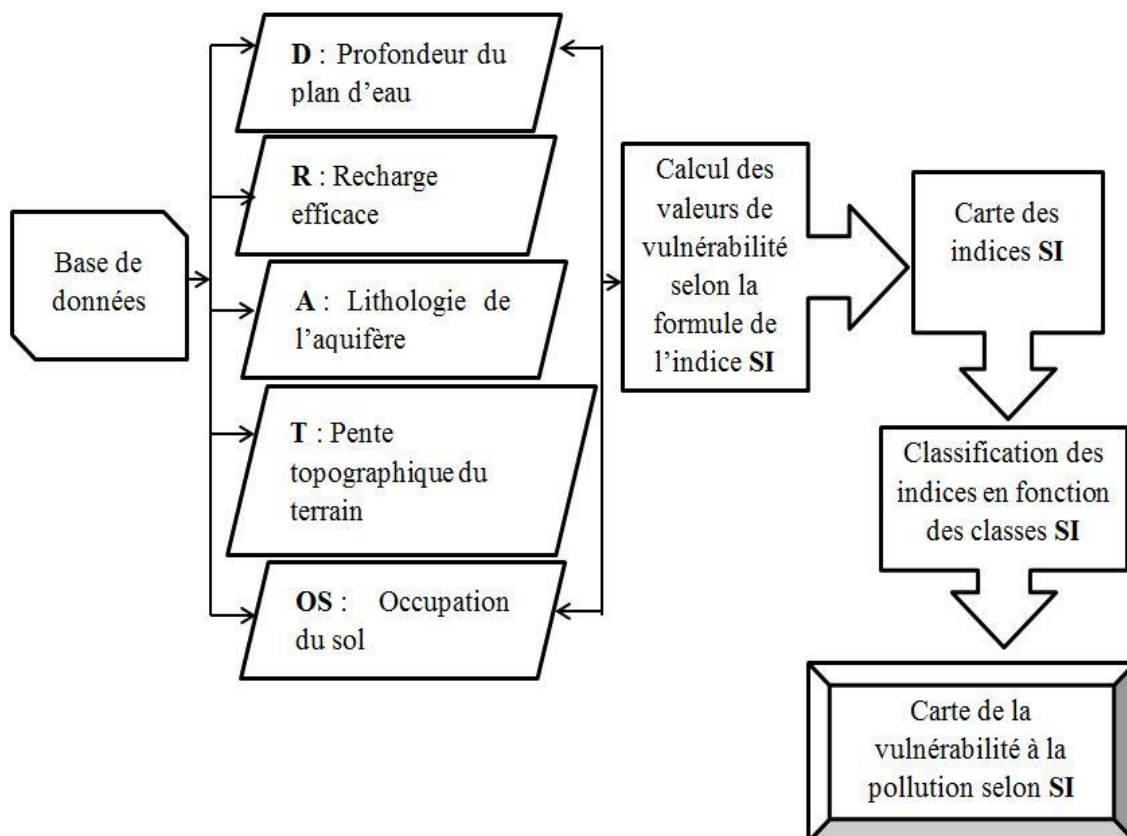

Figure 13: Organigramme de la cartographie de la vulnérabilité à partir de la Méthode SI

Etude comparative des méthodes

## SUSTAINABLE GROUNDWATER DEVELOPMENT

### Groundwater Resources & Hydrogeology

L'analyse de surface permet de connaître la différence qui existe entre les cartes de vulnérabilité élaborées par les différentes méthodes.

Dans l'analyse statistique de surfaces deux aspects sont à considérer :

- la ressemblance des cartes implique des valeurs d'indices identiques d'une carte à l'autre ;
- la concordance implique des cartes qui s'accordent pour la variation des indices d'une zone à l'autre, mais qui ne classent pas les zones avec la même évaluation de l'indice.

En effet, deux cartes de vulnérabilité peuvent être concordantes sans présenter les mêmes indices. La concordance des cartes se traduit par des variations d'indices semblables d'une carte à l'autre sur l'ensemble du territoire (Murat, 2000 in Kouamé 2007).

Pour cette étude, des indices ont été assignés à chaque classe de vulnérabilité comme suit :

Classe de vulnérabilité	Indice
Faible	1
Moyenne	2
Forte	3

Tableau 8 : Indices et Classe de la vulnérabilité

En outre, la surface occupée par chaque classe a été calculée et transformée en pourcentage.

La comparaison deux à deux des surfaces cartographiées par les méthodes permet de connaître la tendance d'évaluation de la vulnérabilité.

A partir de l'outil, "*raster calculator*" du module Spatial Analyst de ArcGIS, la différence des cartes de vulnérabilité a été réalisée deux à deux. En fonction du signe de l'opération, le tableau ci-dessous permet de donner la tendance de l'évaluation de la vulnérabilité. La valeur **nulle** de l'opération indique que les deux méthodes effectuent une évaluation identique

Soit A et B les deux méthodes de cartographies de vulnérabilité à comparer :

Opération	Signe de l'opération	Tendance de l'évaluation
A-B	Négatif	A sous-évalue par rapport à B
A-B	Positif	A sur-évalue par rapport à B

### Etude du risque de pollution

Le risque de pollution résulte du croisement de tous les scénarii possibles de pollution dans la plaine alluviale, comme la distribution spatio-temporelle du polluant (pollution ponctuelle ou diffuse, instantanée ou continue), de la probabilité d'occurrence des événements polluants, et de l'ampleur des conséquences de cette pollution. Il s'agit donc de l'interaction entre la vulnérabilité de l'aquifère à la pollution et les activités anthropiques comme sources de contamination. Le potentiel polluant peut être d'origine agricole (engrais et pesticides) ou urbaine (rejets industriels, eaux usées, polluées, et lessivages des déchets).

La combinaison de ces paramètres permet de dégager les degrés de risque, en tenant compte de degré de vulnérabilité et de l'absence (-) ou la présence (+) des sources polluantes, susceptibles d'altérer la qualité des eaux souterraines.

SUSTAINABLE GROUNDWATER DEVELOPMENT

Groundwater Resources & Hydrogeology

Cette combinaison permet de classer le degré de risque en cinq classes (tableau 9).

Degré de vulnérabilité	Source de pollution	Degré de risque
Très faible	+	Faible
Très faible	-	Très faible
Faible	+	Moyen
Faible	-	Très faible
Moyen	+	Elevé
Moyen	-	Faible
Elevé	+	Très élevé
Elevé	-	Moyen
Très élevé	+	Très élevé
Très élevé	-	Elevé

Tableau 9 : Classification du degré de Risque (SMIDA, 2008)

Résultats principaux et leçons tirées

ANALYSES ET INTERPRETATIONS DES RESULTATS

Étude de la recharge induite

Analyse des facteurs de recharge sur la plaine de Karfiguéla

- **Géomorphologie : topographie**

Le relief dans la plaine de Karfiguéla est très plat dans son ensemble et présente ainsi de faibles pentes (inférieure à 1%) qui empêchent le ruissèlement des eaux de surfaces et favorise leur infiltration.

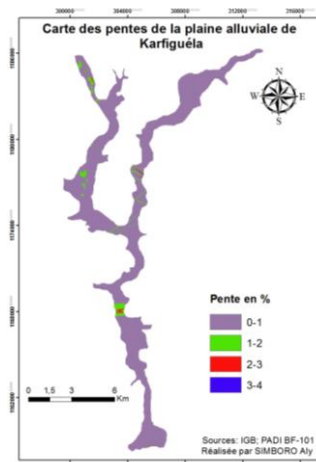

Figure 14 : Carte des pentes de la plaine alluviale de Karfiguéla

- **Hydrographie**

La plaine se trouve sur la Comoé qui est un cours d'eau pérenne. En amont de la plaine, se trouve bon nombre de ramifications de cours d'eau qui lui assurent un débit assez important durant toute l'année.

- **Sol : perméabilité**

La majorité des affleurements dans la plaine de Karfiguéla sont constitués par des alluvions essentiellement par des sables, argiles et limons.

SUSTAINABLE GROUNDWATER DEVELOPMENT

Groundwater Resources & Hydrogeology

La carte de perméabilité obtenue à partir des sols montre que les zones formées par des sables sont les plus favorables à l'alimentation des nappes. Le reste de la zone d'étude présente des terrains moins favorables à l'infiltration.

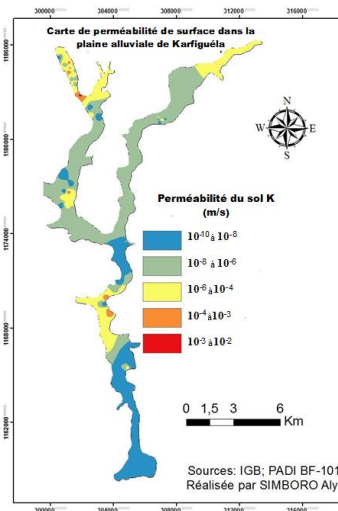

Figure 15 : Carte de la perméabilité de surface de la plaine alluviale de Karfiguéla

• La piézométrie

La carte piézométrique donne un écoulement général de la nappe du Nord vers le Sud.

Les hauts niveaux piézométriques sont remarquables à l'extrême Nord -Est de la plaine (localité de Banfora Nord), à Karfiguéla et au sud de Sitiéna. Les eaux souterraines s'écoulent de ces points hauts vers les points bas.

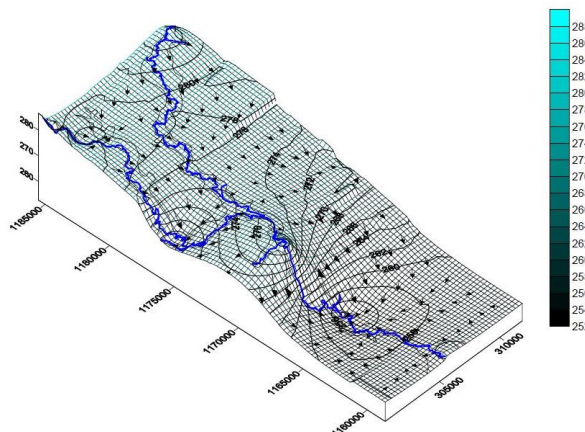

Figure 16: Carte piézométrique 3D dans la plaine alluviale de Karfiguéla

Indentification des zones de recharge induite

La superposition des données a permis l'élaboration d'une carte de recharge induite :



SUSTAINABLE GROUNDWATER DEVELOPMENT

Groundwater Resources & Hydrogeology

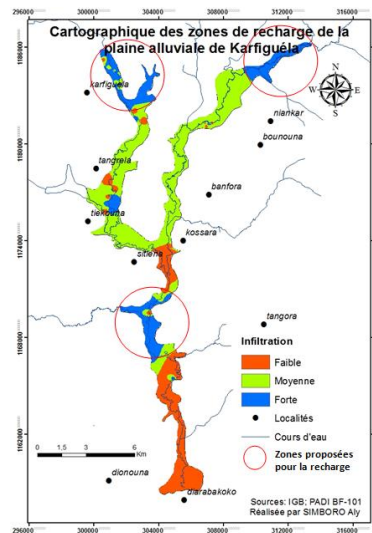

Figure 17 : Carte des zones de recharge induite de la plaine alluviale de Karfiguéla

Le Tableau 10 révèle une distribution des surfaces en fonction des différentes classes des zones d'infiltration de la plaine alluviale de Karfiguéla.

Degré d'infiltration	Pourcentage (%)
Faible	25,22
Moyenne	53,10
Forte	21,68

Tableau 10 : Pourcentage des surfaces en fonction des degrés d'infiltration

Cette cartographie des zones de recharge induite obtenue (Figure 13) permet de mettre en évidence trois classes d'infiltration :

- Une classe d'infiltration faible: elle est localisée au Sud (aval du fleuve) et représente environ 25,22% de la plaine, et caractérise essentiellement les zones, où la profondeur à la surface de la nappe est assez élevée. Le degré d'infiltration faible, peut s'expliquer par la nature argileuse du sol qui a une faible valeur de perméabilité de la couche d'argile ( $10^{-10}$  à  $10^{-8}$  m/s).
- Une classe d'infiltration moyenne : Elle s'étend entre les zones de fortes perméabilités et celles de faibles perméabilités sur une proportion assez importante soit 53,10% de la zone d'étude formée essentiellement limon et d'argile sableuse. Cette infiltration moyenne peut s'expliquer par la perméabilité moyenne des alluvions, favorable à l'infiltration des eaux de surface et donc à l'alimentation des nappes.

Une classe d'infiltration forte : Cette classe occupe 21,68% et se rencontre sur les sites de Karfiguéla, de Banfora Nord et au Sud de Sitiéna essentiellement

- formés des sables ainsi que les éléments grossiers. Les zones d'infiltration forte correspondent à des cuvettes susceptibles à la fois de récupérer les eaux de surfaces mais aussi de constituer des zones favorables à la recharge des nappes. La classe d'infiltration forte est due à la perméabilité très élevée des alluvions ( $10^{-6}$  -  $10^{-2}$  m/s). Tous ces paramètres nous permettent d'observer à la fois les zones de circulation et de stockage des eaux de ruissellement et donc à l'alimentation de la nappe dans la plaine alluviale. Ces zones de fortes infiltrations correspondent aux zones de hautes cotes piézométriques. Les eaux de la nappe s'écoulent de ces zones vers les zones de basses piézométries.

## SUSTAINABLE GROUNDWATER DEVELOPMENT

### Groundwater Resources & Hydrogeology

Les recharges importantes de la nappe se font donc à Karfiguéla, Banfora Nord et au Sud de Sitiéna

Évaluation de la vulnérabilité sur la plaine  
 Analyse des paramètres et cartographie thématique

- **Profondeur de la nappe**

La carte de la bathymétrie montre une nappe peu profonde en général. Les niveaux statiques se situent entre 0,00 et 1,68 m, donnant des valeurs de cotes élevées pour ce paramètre.

Les cotes attribuées selon les différentes méthodes sont résumées dans le tableau ci-dessous :

Cotes obtenues par méthodes			
Profondeur de la nappe (en m)	DRASTIC	GOD	SI
0 – 1.5	10	1	100
1.5 – 2	9		90

Tableau 11 : Cotes attribuées pour la profondeur de la nappe

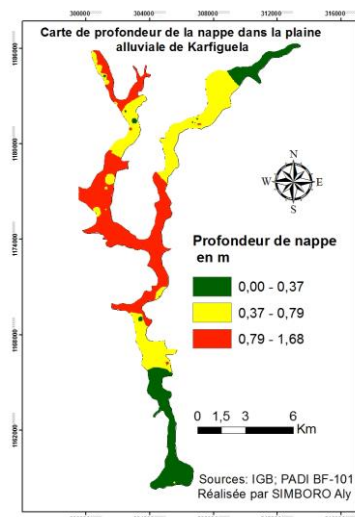

Figure 18 : Carte de profondeur de la nappe de la plaine alluviale de Karfiguéla

- **La recharge efficace :**

La recharge efficace est faible et de l'ordre de 40 mm/an. Les résultats de l'étude de la recharge induite ont permis d'identifier les zones de faible recharge et les zones de forte recharge (Figure 15). L'attribution des cotes s'effectue en tenant compte de ces zones de recharge.

Cotes attribuées par méthodes		
Zone de recharge efficace	DRASTIC	SI
Faible	1	10
Forte	3	30

Tableau 12 : Cotes attribuées pour la recharge

SUSTAINABLE GROUNDWATER DEVELOPMENT

Groundwater Resources & Hydrogeology

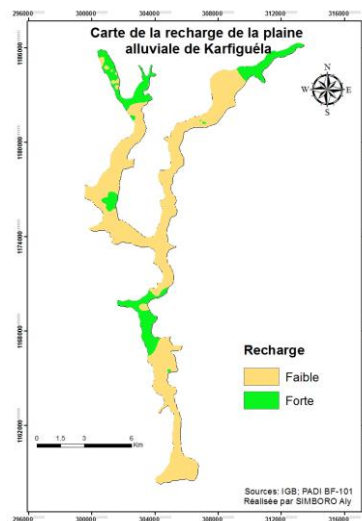

Figure 19 : Carte de la recharge de la plaine alluviale de Karfiguéla

• **Matériaux d'aquifère (A) :**

La plaine alluviale de Karfiguéla a une nappe libre. L'aquifère superficiel est constitué d'alluvions essentiellement argile, limon et sable comme indiquer sur la carte. L'attribution des cotes s'effectue en tenant compte de la capacité de transmissivité des matériaux de l'aquifère.

Le tableau ci-dessous résume les cotes attribuées :

Cotes obtenues			
Type d'aquifère /matériaux		DRASTIC	GOD
Nappe libre	Argile	2	0,8
	Argile limoneux	3	
	Sable argileux	5	
	Sable limoneux	6	
	Sable	8	

Tableau 13 : Cotes attribuées pour l'aquifère

• **La topographie**

La plaine est caractérisée par une topographie plane. Les pentes calculées sur la carte donnent des valeurs très faibles qui sont inférieures à 1% sur la majeure partie du site (Figure 10).

Les valeurs des cotes attribuées pour ce paramètre sont fortes

Cotes obtenues par méthodes		
Pente en %	DRASTIC	SI
0 à 2	10	100
2 à 4	9	90

Tableau 14 : Cotes attribuées pour la pente

• **La zone non saturée**

Au niveau de la nappe de Karfiguéla, pour ce paramètre les formations d'argile, limon, sable argileux, et

SUSTAINABLE GROUNDWATER DEVELOPMENT

Groundwater Resources & Hydrogeology

de sable ont été observées. (Figure 18) Ainsi pour la cotation de ce paramètre, la perméabilité des différentes unités a guidé l'attribution des cotes. (Tableau 16)

Cotes obtenues		
Zone non saturée	DRASTIC	GOD
Argile	3	0,55
Argile limoneux	5	0,62
Sable argileux	6	0,64
Sable limoneux	7	0,66
Sable	8	0,68

Tableau 15 : Cotes attribuées pour la zone non saturée

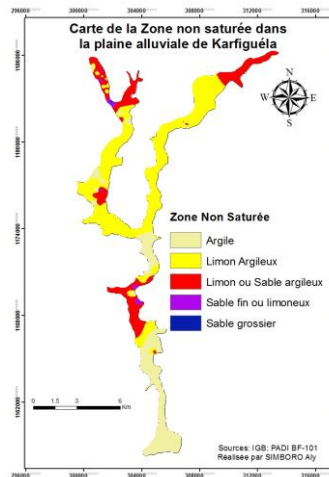

Figure 20 : Carte de la zone non saturée de la plaine alluviale de Karfiguéla

• **La Conductivité hydraulique**

Les valeurs des cotes attribuées aux différents intervalles de conductivité hydraulique, selon DRASTIC, sont consignées dans le tableau :

Cotes obtenues	
Conductivité (m/s)	DRASTIC
$1,5 \cdot 10^{-7} - 5 \cdot 10^{-5}$	1
$5 \cdot 10^{-5} - 15 \cdot 10^{-5}$	2
$15 \cdot 10^{-5} - 33 \cdot 10^{-5}$	4
$33 \cdot 10^{-5} - 5 \cdot 10^{-4}$	6

Tableau 16: Cotes attribuées pour la conductivité hydraulique

SUSTAINABLE GROUNDWATER DEVELOPMENT

Groundwater Resources & Hydrogeology

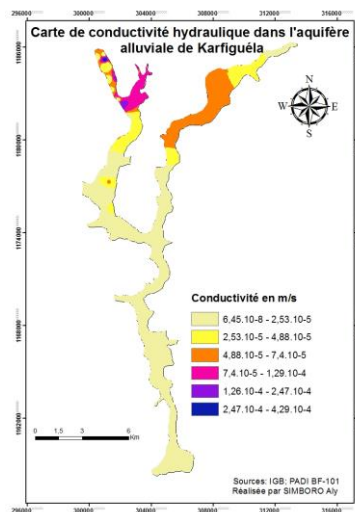

Figure 21: Carte de la conductivité hydraulique de la plaine alluviale de Karfiguèla

• Occupation du sol

La plaine est une zone essentiellement agricole sur près de 90%.

Seule la méthode SI est concernée par ce paramètre, les cotes des classes d'occupation des sols sont résumées dans le tableau ci-dessous :

Tableau attribuées

Classe d'occupation des sols	Cotes
Périmètre irrigués, rizière, cultures annuelles	90
Systèmes culturaux et parcellaires complexes	75
Cultures permanentes	70
Savane	50
Foret et zones semi naturelles	0

17 : Cotes pour

l'occupation des sols

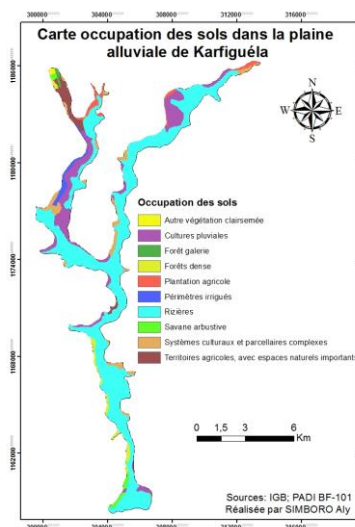

Figure 22 : Carte de l'occupation des sols de la plaine alluviale de Karfiguèla

SUSTAINABLE GROUNDWATER DEVELOPMENT

Groundwater Resources & Hydrogeology

Caractérisation de la vulnérabilité à la pollution dans la plaine alluviale de Karfiguéla

- **Caractérisation de la vulnérabilité selon la méthode DRASTIC**

Les valeurs des indices obtenus oscillent entre 93 et 154 comme présenté sur la carte ci-dessous

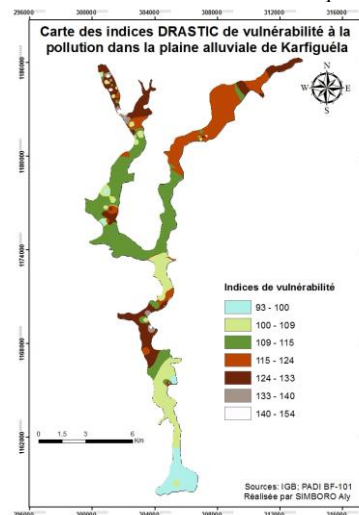

Figure 23 : Carte des indices DRASTIC de la plaine alluviale de Karfiguéla

La carte issue de la classification définie par Aller et *al.* (1987) est illustrée à la figure 22

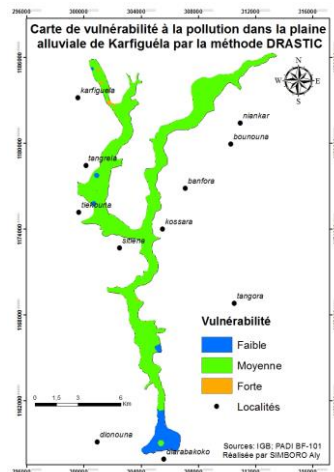

Figure 24 : Carte de vulnérabilité DRASTIC de la plaine alluviale de Karfiguéla

La carte ci-dessus révèle trois (3) classes de vulnérabilité à la pollution:

Classe **Faible** : cette classe n'occupe pas une grande partie de la zone d'étude (8,9%) et peut s'expliquer par le fait que la zone vadose et le sol de cette partie sont constitués essentiellement d'argile.

Classe **Moyenne** : Avec 90,60% des surfaces de la zone d'étude, elle est la classe dominante. Elle garantit une pollution moins sévère dans le cas d'une contamination. Ce degré de vulnérabilité moyen, peut être lié à la nature de la zone non saturée constituée d'argile qui est peu perméable.

Classe **Forte** : très infime, cette classe n'occupe que 0,50% de la nappe de Karfiguéla et serait liée à la nature sableuse de la zone non saturée et du sol.

- **Caractérisation de la vulnérabilité selon la méthode GOD**

SUSTAINABLE GROUNDWATER DEVELOPMENT

Groundwater Resources & Hydrogeology

La carte des indices de vulnérabilité donne des valeurs qui oscillent entre 0,44 à 0,544.

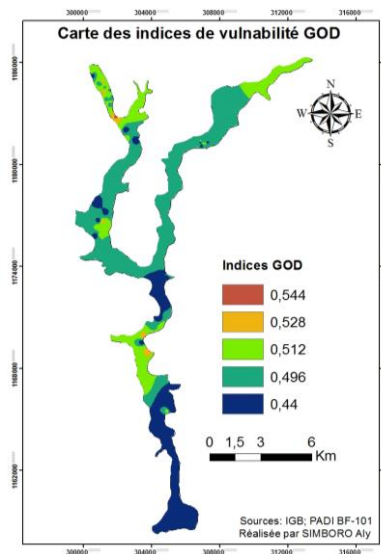

Une classification de ces indices a permis d'établir la carte de vulnérabilité à la pollution par la méthode GOD (Figure 24). L'analyse de cette carte révèle deux (2) classes de vulnérabilité réparties comme suit :  
 Classe **Moyenne**: la plus importante car elle s'étend sur presque toute la zone d'étude (78,32%). Elle garantit une pollution moins sévère dans le cas d'une contamination. Ce degré de vulnérabilité moyen, peut être lié à la nature de la zone non saturée constituée d'argile qui est peu perméable.  
 Classe **Forte**: cette classe occupe une partie du Nord et du Centre de Karfiguéla Elle représente une proportion moins importante que la classe précédente soit 21,68%. Le degré fort de vulnérabilité peut toujours s'expliquer par la nature de la zone non saturée constituée de sable argileux ou sable.

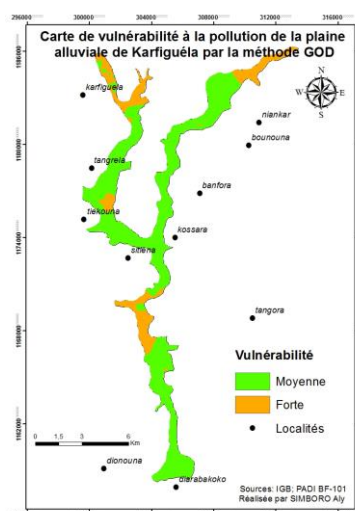

Figure 25 : Carte des indices GOD de la plaine alluviale de Karfiguéla

Figure 26 : Carte de vulnérabilité GOD de la plaine alluviale de Karfiguéla

## SUSTAINABLE GROUNDWATER DEVELOPMENT

### Groundwater Resources & Hydrogeology

- **Caractérisation de la vulnérabilité selon la méthode SI**

Pour la méthode SI, la carte des indices de vulnérabilité spécifique donne des valeurs qui varient entre 40 et 78.

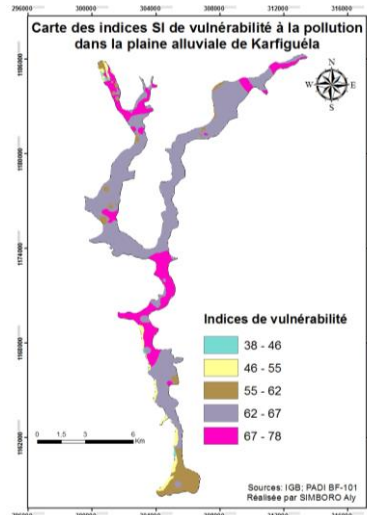

Figure 27 : Carte des indices SI de la plaine alluviale de Karfiguéla

La classification de ces indices a permis d'établir la carte de vulnérabilité à la pollution par la méthode SI (Figure 26). L'analyse de cette carte met en évidence trois classes de vulnérabilité réparties comme suit :

Classe **Faible** : caractérise un degré moindre de vulnérabilité à la pollution. Elle ne représente que 0,42% et occupe quelques espaces aux extrémités de la plaine. Ces zones sont principalement des zones forestières (pas de polluant agricole) d'où le faible indice de vulnérabilité spécifique.

Classe **Moyenne** : assez importante avec 21,28%, elle occupe les bords la plaine. Elle garantit une pollution moins sévère dans le cas d'une contamination. Ce degré de vulnérabilité moyen, peut être lié à la nature de la zone non saturée constituée d'argile qui est peu perméable.

Classe **Fort** : C'est la classe dominante de la zone d'étude sur 78,3%. Le degré fort de vulnérabilité s'explique par le fait que ces zones sont fortement agricoles donc avec probable utilisation de polluant d'origine agricole.



## SUSTAINABLE GROUNDWATER DEVELOPMENT

### Groundwater Resources & Hydrogeology

#### DISCUSSIONS

La complexité dans la réalisation des cartes de recharge induite ou de vulnérabilité à la pollution réside dans le nombre de facteurs hydrogéologiques à prendre en compte. Plusieurs paramètres comme la conductivité hydraulique, la profondeur à la nappe, l'impact de la zone vadose, ont été produites par interpolation ce qui entraîne des erreurs dans la réalisation des paramètres (Kouamé, 2007).

Par ailleurs, l'une des difficultés de l'application des méthodes de cartographie de vulnérabilité est l'assignation des limites de classes et des cotes aux différents paramètres (Murat, 2000 in Kouamé, 2007). En effet, les limites des classes standards ne reflètent pas souvent la réalité de la zone d'étude car ces classes peuvent regrouper en leur sein des entités différentes (Lobo-Ferreira et al., 2003 in Feumba 2014). En dépit des différentes limites soulevées dans l'établissement des cartes de vulnérabilité à la pollution par les méthodes intrinsèques, il n'en demeure pas moins que la carte de vulnérabilité intrinsèque est fiable. Kouamé a cité plusieurs travaux qui ont également abouti à une telle conclusion : Anani (2006), Fofana (2005), Murat et al., (2003) et Murat (2000). Elle permet d'avoir une idée sur les zones sensibles qu'il va falloir prendre en compte lors de l'aménagement du territoire (Jourda, 2005).

L'étude de la vulnérabilité à la pollution par les méthodes DRASTIC, GOD et SI a permis de déceler trois classes de vulnérabilité faible, modérée, et forte. L'analyse des cartes de vulnérabilité à la pollution des eaux souterraines de la plaine a révélé que le degré de vulnérabilité croît avec la perméabilité du sol et de la zone non saturée. Ces zones se situent aux endroits où il y a une présence de sable près de la surface. Les secteurs à faible vulnérabilité se trouvent au niveau des zones tampons, c'est-à-dire là où l'argile est présente.

L'analyse des fréquences de surface des cartes de vulnérabilité révèle que les méthodes intrinsèques que sont DRASTIC et GOD ont un grand accord (69,91%) : elles présentent une dominance pour la classe de vulnérabilité moyenne. Mais la méthode GOD a tendance à surévaluer la vulnérabilité par rapport à DRASTIC. Pour la comparaison des méthodes intrinsèques avec la méthode SI, il ressort qu'il y a dans l'ensemble un faible accord entre SI et DRASTIC (13,13%), et entre SI et GOD (33,17%). Aussi d'une manière générale, la méthode SI a tendance à surévaluer la vulnérabilité par rapport aux deux autres méthodes.

Les cartes de vulnérabilité à la pollution ont pour but de montrer les grandes tendances de la vulnérabilité pour l'affectation d'activités à risque.

Les zones de recharge sont reconnaissables à une vulnérabilité plus forte. La méthode permet cependant de classer les secteurs en fonction du degré d'infiltration. Cela veut donc dire que, pour certains secteurs, l'attribution de cotes aurait pu être réalisée de manière plus précise. Comme on l'a mentionné plus haut, étant donné la variabilité des paramètres utilisés par les deux méthodes, on s'attendrait à ce que les cartes de vulnérabilité mettent en évidence les zones de recharge. Si on compare les deux méthodes, on remarque que la méthode GOD permet d'obtenir une variabilité dans la représentation de la vulnérabilité (Figure 24). La classification des intervalles d'indices de vulnérabilité selon Aller et al., semble ne pas être appropriée, il faut donc penser à une classification relative et adaptée aux conditions géologiques et hydrogéologiques de la zone étudiée.

Les cartes obtenues sont des cartes d'aide à la décision. Comme dans tout autre produit résultant de la manipulation ou traitement de jeux de données, ces cartes peuvent contenir des erreurs dont la source provient depuis l'acquisition de données, en passant par leur traitement ou du fait d'une couverture spatiale assez limitée des données. Pour une éventuelle exploitation de telles cartes, il est donc important que l'information sur les données, leur mode de traitement et la qualité des données soient rendus

## SUSTAINABLE GROUNDWATER DEVELOPMENT

### Groundwater Resources & Hydrogeology

disponibles. Dans tous les cas, ces méthodes de vulnérabilités intrinsèques permettent de se faire une idée assez précise sur les zones sensibles d'une région donnée en vue de prendre des dispositions de protection nécessaires.

### CONCLUSION

Ce travail de fin d'étude est une contribution pour une meilleure gestion des ressources en eau dans la plaine alluviale de Karfiguéla à travers une étude de la recharge induite de la nappe et de sa vulnérabilité à la pollution. Pour ce faire, nous avons utilisé un Système d'Information Géographique (SIG) avec des données de plusieurs domaines (géologie, hydrogéologie, hydrologie, sociologie...). En effet, l'intégration et le traitement de données multiples dans l'environnement ArcGIS facilitent l'analyse spatiale et l'interprétation des phénomènes naturels.

Les principaux apports de ce mémoire sont de deux (2) ordres :

- L'évaluation de la recharge induite de la nappe alluviale de Karfiguéla

La recharge induite est considérée comme une solution à plusieurs problèmes d'alimentation et de gestion des ressources en eau et cela passe par l'identification et la caractérisation des sites potentiels de recharge. La superposition des différentes couches d'informations à l'aide du SIG a permis de proposer des zones de recharge induite.

**Les zones caractérisées par des formations sableuses sont les plus perméables et donc les plus favorables à l'infiltration.**

- La cartographie de la vulnérabilité à la pollution des eaux souterraines de la plaine alluviale de Karfiguéla selon différentes méthodes

Elle a permis de dresser le portrait de la défense naturelle de l'aquifère de Karfiguéla contre les pollutions à partir des méthodes DRASTIC, GOD et SI. Cette cartographie a également permis de faire la comparaison entre ces différentes méthodes. L'objectif a donc été atteint. De cette étude il ressort que les méthodes intrinsèques fournissent de meilleurs résultats d'évaluation de la vulnérabilité par rapport à la méthode SI. Leur application sur la plaine de Karfiguéla a montré que la nappe est vulnérable à pollution dans son ensemble. Cette vulnérabilité est accentuée au niveau des zones sableuse qui ont une forte vulnérabilité à la pollution et présentent un risque très élevé de pollution du fait des pratiques agricoles. Ces zones de forte vulnérabilité représente 21,58 % du bassin. Quant à la carte de vulnérabilité à la pollution d'origine agricole établie par la méthode SI, elle surévalue la vulnérabilité à la pollution de la plaine alluviale de Karfiguéla avec 78,30% de zones fortement vulnérables.

**Les zones les plus favorables à la recharge sont aussi les plus vulnérables. Il apparait donc nécessaire d'entreprendre des mesures de protection des ressources en eau dans la plaine alluviale de Karfiguéla.**

Cette expérience a montré que les SIG sont d'un apport majeur sur plusieurs plans. L'automatisation, l'analyse, la rapidité de manipulation et la mise en mémoire des données avec capacité de réactualisation ont donné pleine satisfaction.

### RECOMMANDATIONS - PERSPECTIVES

Dans la plaine alluviale de Karfiguéla les eaux de surface constituent la principale ressource pour l'agriculture irriguée, cependant on assiste à une augmentation de l'exploitation des eaux souterraines. Aussi la nappe de Karfiguéla est libre, dépourvue de tout type de recouvrement imperméable, elle est propice à la pollution percolant de la surface. De ce fait le Ministère de l'Eau et de l'Assainissement du

## SUSTAINABLE GROUNDWATER DEVELOPMENT

### Groundwater Resources & Hydrogeology

Burkina Faso doit instaurer des mesures, dans le cadre d'une gestion des ressources en eau, visant à assurer la qualité et la quantité de la nappe, :

Cette gestion nécessite la disponibilité de données fiables qui permettront une évaluation fine et adéquate des différents paramètres. En plus, l'implication directe des populations est indispensable, pour une meilleure application. C'est pourquoi nous préconisons :

- Renforcer le réseau de suivi des ressources en eau avec plus de piézomètres dans la plaine et même hors de la plaine.
- Réaliser des essais de pompages pour déterminer les paramètres hydrodynamiques, en particulier le coefficient d'emmagasinement,
- Caractériser au mieux les sols et réaliser des mesures d'infiltrométrie.
- Renforcer le suivi de la qualité des eaux, surtout dans les zones à forte vulnérabilité, cela permettra de détecter toute pollution à temps, et de prendre des mesures conséquentes;
- Mettre en place une base de données (et son actualisation fréquente) sur les sources de pollution, à travers le type et la quantité des intrants agricoles, pour mieux suivre l'évolution du risque. Ceci permettra de soumettre à des restrictions d'usage ceux qui, d'une manière générale, contaminent fréquemment les milieux aquatiques (rivières ou eaux souterraines), afin de limiter leur impact.
- Améliorer la recharge avec des ouvrages tels que les bassins d'infiltration, les checks dams ou les digues d'épandage au niveau des zones favorables à la recharge. Ces ouvrages, le plus souvent construits avec des matériaux locaux, peuvent être permanents ou temporaires, fonctionner continuellement ou par intermittence, être placés dans le lit du cours d'eau ou à proximité.
- Mettre en place des périmètres de protection autour des captages se trouvant dans les zones de forte vulnérabilité. Cette procédure constitue un moyen de prévention face aux pollutions ponctuelles ou accidentelles et cela à travers trois types de périmètres : le périmètre de protection immédiate (zone très limitée autour du captage, exclusivement destinée aux activités liées au prélèvement de l'eau) ; le périmètre de protection rapprochée (à l'intérieur duquel les installations et les activités pourront être réglementées ou interdites) ; le périmètre de protection éloignée (non obligatoire, à l'intérieur duquel les installations et activités pourront être réglementées sans toutefois y être interdites)
- Vérifier la validité des méthodes d'évaluation de la vulnérabilité à la pollution en se basant sur des données chimiques des eaux souterraines (porté sur l'analyse du taux de nitrates). Cette validation des cartes de vulnérabilité établies pourrait être plus représentative avec un nombre plus important de mesures de nitrates bien réparties sur toute la plaine,
- Elaborer un plan de gestion concerté : Sensibiliser les agriculteurs dans le cadre d'une gestion intégrée de la ressource en eau souterraine et de l'environnement dans les zones concernées aboutissant à un aménagement autour des sources (Zone agricole, espaces à utilisation contrôlée, espaces à exploitation interdite et l'implication des acteurs) : Sensibiliser les populations à l'utilisation rationnelle des engrais et intrants agricoles.

### Mentions

**MAHRH** : Ministère de l'Agriculture, de l'Hydraulique et des Ressources Halieutiques du Burkina Faso

**APEFE** : Association pour la Promotion de l'Education et de la Formation à l'Etranger

**WBI** : Wallonie-Bruxelles International

### Références

Ouvrages et articles

BETAN Noël (2014), Caractérisation de l'hydrodynamisme de la plaine alluviale de Karfiguéla, mémoire de master, Institut International d'Ingénierie de l'Eau et de l'Environnement (2iE).

## SUSTAINABLE GROUNDWATER DEVELOPMENT

### Groundwater Resources & Hydrogeology

- BIEUPOUDE Pascal (2008), Mapping groundwater intrinsic vulnerability using a new physically based modeling in Kou basin.
- DAO Djamilatou (2015); Taux d'exploitation et durabilité de la ressource en eau des aquifères alluviaux du Kou et de Karfiguéla, mémoire de master, Institut International d'Ingénierie de l'Eau et de l'Environnement (2iE)
- FEUMBA Roger (2015) ; Hydrogéologie et évaluation de la vulnérabilité des nappes dans le bassin versant de Besseke (Douala, Cameroun) Thèse de doctorat, Université de Yaoundé I
- FOFANA Yacouba (2014), Caractérisation hydrogéologique et vulnérabilité des sources de Nasso et de Pessô à la pollution d'origine agricole, mémoire de master, ENI
- GOMBERT Philippe (1998), Synthèse sur la Géologie et l'hydrogéologie de la série sédimentaire du sud-ouest du Burkina Faso,
- HALADOU Laouali (2013), Caractérisation des matériaux et de la puissance de la plaine alluviale de Karfiguéla par des investigations géophysiques, mémoire de master, Institut International d'Ingénierie de l'Eau et de l'Environnement (2iE).
- KHEMIRI S., KHNISSI A., ALAYA1 M. B., SAIDI S. et ZARGOUNI F.(2013) Using GIS for the Comparison of Intrinsic Parametric Methods Assessment of Groundwater Vulnerability to Pollution in Scenarios of Semi-Arid Climate. The Case of Foussana Groundwater in the Central of Tunisia; *Journal of Water Resource and Protection*, 2013, 5, 835-845
- KOUAME Kan Jean (2007), Contribution à la Gestion Intégrée des Ressources en Eaux (GIRE) du District d'Abidjan (Sud de la Côte d'Ivoire) : Outils d'aide à la décision pour la prévention et la protection des eaux souterraines contre la pollution Thèse de doctorat, Université de Cocody
- NDJOMO TSIMI Pierrick (2015) Modélisation mathématique appliquée à l'hydrogéologie : Modélisation numérique du comportement hydrodynamique de l'aquifère alluvial de Karfiguéla, mémoire de master, Institut International d'Ingénierie de l'Eau et de l'Environnement (2iE)
- RAVI S. M. N. and MOHAN G. A GIS based hydrogeomorphic approach for identification of site-specific artificial-recharge techniques in the Deccan Volcanic Province. *J. Earth Syst. Sci.* 114, No. 5, October 2005, pp. 505–514
- SAINT-PE Max A. Alimentation artificielle des nappes *Bulletin of the International Association of Scientific Hydrology*, XVI, 2. 6/1971
- SARAVANAN Identification of Artificial Recharge Sites in a Hard Rock Terrain using Remote Sensing and GIS, *International Journal of Earth Sciences and Engineering* ISSN 0974-5904, Vol. 05, No. 06, December 2012, pp. 1590-1598
- SMIDA H., MAIZA N., ZAIRI M. et BEN DHIA H. Gestion quantitative et qualitative des ressources en eaux dans la région de Sidi Bouzid (Tunisie centrale) à l'aide d'un SIG : Etude de la recharge induite des nappes et leur vulnérabilité à la pollution, ESRI France 2015
- SMIDA H., ZAIRI M., TRABELSI R. et BEN DHIA H. Identification de zones de recharge induite d'aquifères à l'aide d'un Système d'information géographique : cas de la nappe de Chaffar (Sud-Est tunisien). *Sécheresse* 2006 ; 17 (3) : 433-42
- Sites internet  
<http://www.esrifrance.fr/sig2008/DRASTIC.htm>, consulté le 21 Aout 2015  
<file:///sigenis.htm>, consulté le 7 Septembre 2015  
<http://www.toupie.org/Dictionnaire/Vulnerabilite.htm>, consulté 13 Aout 2015

SUSTAINABLE GROUNDWATER DEVELOPMENT

Groundwater Resources & Hydrogeology

---

## Conception et élaboration de cartes hydrogéologiques au 1:500 000 et 1:200 000 des régions nord et est du Tchad et gestion des ressources hydriques

---

Article court

Haerberlin, Y. <sup>a, b</sup>, Kraiem-Morard, A. <sup>b</sup>, Aubert, M. <sup>b</sup>, Zwahlen, F. <sup>c</sup>, Bünzli, M.-A. <sup>a</sup>, Musa Mohammed; I. <sup>d</sup>, Sénégas, O. <sup>b</sup>, Guidotti, G. <sup>e</sup>

<sup>a</sup> Aide Humanitaire et CSA, Direction du Développement et de la Coopération (DDC), Berne, Suisse

<sup>b</sup> UNOSAT, Institut des Nations Unies pour la Formation et la Recherche (UNITAR), Genève, Suisse

<sup>c</sup> Centre d'Hydrogéologie et de Géothermie de l'Université de Neuchâtel (CHYN), Suisse

<sup>d</sup> Ministère de l'Hydraulique, N'Djaména, Tchad

<sup>e</sup> Bureau de la coopération suisse DDC, N'Djaména, Tchad

### Abstract/Résumé

Le projet ResEau a pour objectif d'accroître la capacité du Tchad à gérer de manière durable ses ressources en eau souterraine et de surface. L'accent a été mis lors de la 1<sup>ère</sup> phase (2012-2015) sur l'amélioration des connaissances dans les régions est et nord du Tchad où s'exercent les plus fortes pressions pastorales et villageoises (Wadi Fira, Ouaddaï, Sila, Ennedi Est, Ennedi Ouest, Borkou, Tibesti). Un Système d'Information des Ressources en Eau (SIRE) a été conçu et établi, regroupant les géodonnées liées à l'eau, à la géologie et aux sols ainsi qu'un fond topographique actualisé. En interprétant de manière exhaustive et novatrice des images et données satellite et en croisant ces interprétations avec des données de puits et forages, une série complète de cartes hydrogéologiques de reconnaissance au 1: 500 000 a été produite et publiée. Elle est complétée par une série réduite de cartes Ouvrages et Ressources au 1: 200 000, fournissant des informations hydrogéologiques plus complètes sur des zones restreintes. Ces nouvelles connaissances et produits cartographiques vont permettre au cours de la 2<sup>ème</sup> phase du projet (2016-2019) de progressivement mettre en place de nouvelles stratégies de gestion des ressources hydriques.

### Introduction

Les ressources en eau des régions nord, nord-est et est du Tchad sont peu connues en détail. Seuls les travaux d'adduction en eau potable de quelques agglomérations importantes et de nombreux puits à usage domestique, d'irrigation ou d'élevage dispersés dans cette immense zone permettent de connaître de façon succincte le potentiel en eau. Cette situation à l'évidence insatisfaisante a conduit les autorités tchadiennes à lancer, en partenariat avec la Coopération suisse, le projet ResEau qui intègre le développement d'un système d'information sur les ressources en eau (SIRE) consacré à l'ensemble de ces régions. Les cartes hydrogéologiques en sont une visualisation sous une forme traditionnelle, qui complète l'établissement d'autres représentations thématiques sur support informatique.

L'objectif général du programme ResEau est d'augmenter la capacité du Tchad à gérer de manière durable ses ressources en eau souterraine et en eau de surface, en tenant compte d'une évolution climatique peu favorable. Plus précisément, le programme vise à 1) améliorer les connaissances sur les aquifères et les écoulements de surface pour développer et consolider les activités en cours dans ce secteur, 2) renforcer les capacités nationales dans les domaines de l'hydrogéologie et des systèmes d'information géographiques, et 3) contribuer à la mise en place sur le long terme d'une gestion durable des ressources en eau du pays.

## SUSTAINABLE GROUNDWATER DEVELOPMENT

### Groundwater Resources & Hydrogeology

Le projet ResEau est planifié sur 9 ans, et sa première phase d'implémentation, d'une durée de 3 ans et demi, s'est tenue de mars 2012 à novembre 2015. La DDC et la République du Tchad ont chargé l'Institut des Nations Unies pour la Formation et la Recherche (UNITAR), plus précisément son programme opérationnel pour les applications satellitaires UNOSAT, de mettre sur pied la première phase de ce projet et de le piloter.

### Cartes hydrogéologiques et Système d'Information SIRE

La première phase du projet ResEau a permis d'améliorer significativement les connaissances sur la nature, l'extension et les potentialités des ressources en eau de zones essentiellement désertiques, correspondant aux régions du Wadi Fira, du Ouaddaï, du Sila, de l'Ennedi Est, de l'Ennedi Ouest, du Borkou et du Tibesti. Deux séries de cartes hydrogéologiques ont été élaborées. La première, à l'échelle 1:500 000, couvre l'ensemble de la zone nord et est du pays par l'assemblage de huit cartes contiguës présentant la nature, la localisation et la productivité relative des différents réservoirs aquifères régionaux. Plusieurs cartouches spécifiques relatives au climat, à la qualité des eaux et à différents aspects socio-culturels de la région cartographiée y sont également présentées au verso. La seconde série de cartes, à l'échelle 1:200 000, comporte une vingtaine de cartes, les unes localisées autour des agglomérations importantes, les autres recouvrant des sites d'importance hydrologique remarquable, et qui fournissent des informations détaillées sur les ressources en eau de zones spécifiques.

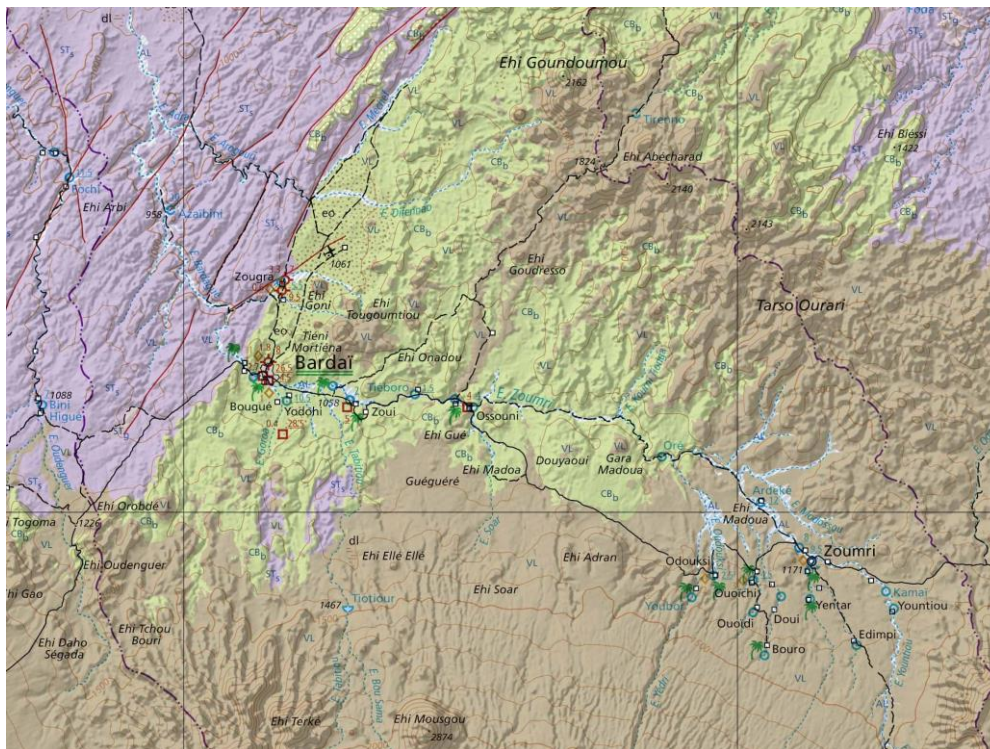

Fig 1. – Hydrogéologie et points d'eau de la région de Bardaï, Tibesti, exemple extrait de la carte hydrogéologique de reconnaissance au 1:500 000 du Tchad, feuille NF-33-SE Pic Toussidé.

L'établissement de telles cartes (Fig. 1) implique la compilation puis l'analyse d'une documentation hydrogéologique importante et détaillée. Dans une grande partie des régions concernées, celle-ci est encore largement lacunaire ou imprécise. Pour pallier cette situation et compte tenu des difficultés d'accès de cette immense région, le projet ResEau a décidé de recourir de manière conjointe à deux approches indirectes: la première, classique, a consisté à reconstituer l'hydrogéologie régionale et locale en la déduisant pour l'essentiel de travaux géologiques préexistants, cela en se référant à différents travaux disponibles, notamment ceux de Schneider (2001a,b); la seconde, plus novatrice, a recouru au traitement approfondi de nombreuses données satellite, dont le contenu directement ou indirectement en relation avec l'hydrogéologie régionale a été extrait selon les méthodes les plus récentes. Le travail cartographique

## SUSTAINABLE GROUNDWATER DEVELOPMENT

### Groundwater Resources & Hydrogeology

a également nécessité un gros effort de synthèse des paramètres des puits et forages, qui repose autant sur les données souvent incomplètes et parfois peu fiables de la base de données SITEAU (MH, 2016), que sur d'autres banques de données de projets d'hydraulique villageoise et pastorale. L'exécution de ce volet cartographique a aussi conduit à mettre sur pied cinq missions scientifiques comprenant experts tchadiens et internationaux dans le but de vérifier l'interprétation des images satellite, de clarifier l'identification des différentes formations aquifères et de préciser ou compléter les données de terrain, notamment celles relatives aux points d'eau.

La méthodologie appliquée à l'élaboration des ces cartes hydrogéologiques est présentée en détail dans l'article long.

Utilisé pour produire les cartes hydrogéologiques, un Système d'Information des Ressources en Eau (SIRE) regroupe l'ensemble des géodonnées liées à l'eau, à la géologie et aux sols, un fond topographique actualisé et des images satellite sur les régions ciblées au nord et à l'est du Tchad. Ce SIRE est complété par une base documentaire de rapports techniques, publications et anciennes cartes. Un portail cartographique (<http://geoportal.reseau-tchad.org>) permet d'accéder en ligne à l'ensemble des informations géographiques produites et intégrées dans le SIRE ainsi qu'à la base de données SITEAU, qui rassemble les ouvrages hydrauliques du territoire tchadien.

### Principaux résultats et enseignements

A l'issue de la première phase du projet, les résultats suivants ont été obtenus:

- La publication de 8 Cartes hydrogéologiques de reconnaissance au 1:500 000, de 21 Cartes Ouvrages et Ressources plus détaillées au 1:200 000, et de 2 Cartes hydrogéologiques hors série (les Oasis de Faya-Largeau au 1:150 000 et les Lacs d'Ounianga au 1:100 000).
- La mise en ligne d'un portail cartographique sur les ressources en eau du Tchad, regroupant l'ensemble des informations créées.
- La construction et la mise en service d'un centre d'information géographique et de documentation au Ministère de l'Hydraulique.
- La conduite du Master HydroSIG à l'Université de N'Djaména, une formation en hydrogéologie et systèmes d'information géographiques pour les professionnels du secteur de l'eau.

Les résultats du projet ResEau ont commencé à être diffusés depuis près d'une année auprès des acteurs de l'eau au Tchad et quelques premiers enseignements ont pu être tirés:

- Un renforcement et développement des compétences des acteurs locaux est à prôner pour garantir une compréhension et une appropriation des nouvelles connaissances et cartes.
- L'utilisation des données et des nouvelles connaissances pour une gestion active des ressources hydriques est un processus qui nécessite plus d'attention et d'efforts que la création de l'information.

### Conclusions

Une vaste partie du territoire tchadien, en zone sahélienne et saharienne, souffre d'une pénurie chronique d'eau, alors que le pays dispose d'importantes ressources en eau souterraines et de surface. Cette situation est due à un manque de connaissances de l'état et la nature des ressources et à la difficile implémentation de la politique de l'eau au Tchad. A la fin de la 1<sup>ère</sup> phase du projet ResEau, de nouvelles connaissances sur les aquifères et 31 cartes hydrogéologiques sont disponibles pour les régions est et nord du Tchad. De premiers exemples de l'utilisation de ces produits pour une meilleure gestion des ressources hydriques sont proposés lors du 7<sup>ème</sup> forum RWSN ainsi qu'un retour sur l'expérience des ateliers techniques conduits dans les villes d'Abéché et Biltine. La mise en œuvre et l'appropriation de ces nouveaux outils se poursuivra à N'Djaména et dans les régions lors de la 2<sup>ème</sup> phase, qui se poursuit jusqu'en 2019.

### Références

Schneider, J.L., 2001a. Carte de valorisation des eaux souterraines au 1:1 500 000 de la République du Tchad. *Ministère de l'Environnement et de l'Eau, Direction générale, Direction de l'Hydraulique.*

## SUSTAINABLE GROUNDWATER DEVELOPMENT

### Groundwater Resources & Hydrogeology

Schneider, J.L., 2001b. Géologie, archéologie, hydrogéologie de la République du Tchad – 2 volumes. *Ministère de l’Environnement et de l’Eau, Direction générale, Direction de l’Hydraulique.*

MH, 2016. SITEAU, Système d’Information Tchadien sur l’EAU. Base de données des ouvrages hydrauliques, mars 2016. *Direction des Ressources en Eau, N’Djaména.*

#### Notes

Le projet ResEau, dans sa première phase, a été financé par la Direction du développement et de la coopération (DDC) de la Confédération suisse et par la République du Tchad. En dehors des acteurs principaux que sont le Ministère de l’Hydraulique et l’UNITAR-UNOSAT, de nombreuses institutions ont été impliquées dans la réalisation du projet: le Ministère de l’Enseignement Supérieur et de la Recherche Scientifique (MESRS), le Consortium des universités et instituts du Tchad (CUIT), le Centre national d’appui à la recherche (CNAR), le Centre d’hydrogéologie et de géothermie de l’Université de Neuchâtel (CHYN), l’Office fédéral de topographie (swisstopo) et le Centre de recherche sur l’environnement alpin (CREALP).

L’ensemble des informations et résultats du projet est disponible à l’adresse web <https://reseau-tchad.org>



SUSTAINABLE GROUNDWATER DEVELOPMENT

Groundwater Resources & Hydrogeology

## Nurturing Water: Ancestral Ground Water Recharging in the Americas

Type: Long paper

**Author:** Kashyapa A. S Yapa, Ph.D. (UC Berkeley), Independent consultant, Ecuador, kyapa@yahoo.com, 593-3-2394809/ 593-986267632

**Abstract:** For a groundwater supply to be sustainable, its rate of recharging needs to match the demand. If natural replenishing rate falls short of the demand, water users have to take steps to enhance it. That requires a good understanding of the groundwater flow mechanism in the locality, a quite difficult task even for today's water experts. Evidence shows that our ancestors used their observational skills and trial and error techniques to overcome this difficulty. When the leaders had to mobilize the villagers for construction and maintenance, they incorporated religious rituals with every activity, thus transferring to the collective faith the responsibility for proper functioning of the recharging mechanism. We use some cases from the Americas to elucidate different techniques our ancestors employed in recharging groundwater. These technologies have a great potential for today's water-stressed watersheds, but only after adapting them to local conditions.

### Introduction

The first raindrops percolating through the ground surface may adhere to solid particles or fill the tiny spaces around them, and thus, stay near the surface. A part of that water may return to the surface through capillary action and evaporate, while nearby plant roots may absorb another part. If rainfall continues, some drops will travel deeper to feed the groundwater. This natural groundwater recharging process works better if the surface soil is more porous and if runoff velocity is smaller. Therefore, any vegetation covering the surface soil helps increase the rate of infiltration.

Since ancient times, large human settlements prospered in dry zones because of greater agricultural productivity there. Rainstorms in dry zones are generally very intense and cause flash floods, which do not allow much infiltration and groundwater recharge. On the other hand, in these climates, people have to rely more on groundwater because surface water evaporates fast. Thus, they have to find ways to augment the natural recharging process in order to guarantee their long-term survival. Precisely understanding the movement of groundwater is a challenge, even with today's sophisticated geological and geophysical knowledge and equipment. Then, how did our ancestors manage to procure groundwater in quantities sufficient to support large towns and agricultural lands in desert areas?

### Context and aims

In this paper, we intend to explore the knowledge and practices related to groundwater management of precolonial States and communities that successfully populated drier areas in the American continent. Our inability to correctly interpret and comprehend precolonial administrative records greatly hinders our understanding of such technologies. From the early days of European invasion of the American continent, the newcomers expressed their surprise at large public infrastructure works, like roads, irrigation systems, terraces and ceremonial buildings, built and maintained by a population whom they had considered technologically inferior.

Unfortunately, no serious investigations were carried out to find how those structures were built. The European colonial administrations focused primarily on extracting and exporting as many local resources as possible for the benefit of their empires. The independent, republican administrations that followed neither spent sufficient effort to understand and promote native technologies because a colonial mentality prevails until today among many a political leadership. Over the last few decades, some archaeological investigations on precolonial water supply systems have been done, partly to boost tourism and partly out of academic interest. However, the limited scope of those investigations and their funding do not permit us to have a thorough understanding on how precolonial users managed their groundwater resources.

## SUSTAINABLE GROUNDWATER DEVELOPMENT

### Groundwater Resources & Hydrogeology

Despite a limited amount of data, we aim to shed light on the existence of ancient groundwater management systems in the American continent and share this knowledge with a wider audience. We hope that, in this way, more practitioners, policy makers, technicians and other professionals can become aware of and be vigilant to discover possible locations where local populations can benefit from such resources.

We will describe our case studies from the point of view of a community leader with limited technical knowledge searching for a reliable water source in a dry zone. She has access to only the observational information about the quality and quantity of water from that particular source. She will match that information with the community demand for water. If the historical data are sufficiently precise, she can establish reliability and sufficiency of that water supply over the long run. If periodical deficits in quality and quantity were to occur, the community leader will face a complex situation. Generally, augmenting the flow of a natural groundwater supply could improve the quality as well. Yet, lacking access to technical knowledge on how to recharge groundwater with the least effort, she has to tap into ancestral experiences, or to take the risk and practice trial and error methods. The risk lies in mobilizing community labor to conduct large-scale groundwater recharging operations without knowing whether the result would favor the community. If it would not, she would lose credibility.

We suggest that, based on our observations and archeological investigations, our ancestors solved this problem by insisting that public works begin and end with rituals, offerings and appeals to the deities, embedding them into groundwater management practices. The ceremonies help shift the burden of uncertainty from the leader's judgment to the participants' faith on supernatural forces. Moreover, such rituals strengthen the sense of unity and belonging, thus increasing community resilience. Many rural communities continue to maintain their groundwater supplies by applying such knowledge systems and practices, since technical expertise is hard to come by.

### Case studies

#	Community	Country	Description of the technique
1	Highlands of Ayacucho	Peru	shallow water holes dug by shepherds to trap runoff contribute through infiltration
2	Huamantanga, Lima	Peru	unpaved artificial ponds fed with canals to sustain dry season flow of small springs
3	Santa Elena & Manabi	Ecuador	unpaved artificial lagoons capture runoff & sustain dry season flow of streams
4	Chan Chan, Trujillo	Peru	irrigating upslope agricultural lots to feed downstream city pools and sunken fields
5	Huamantanga, Lima	Peru	dumping stream runoff on rocky slopes to sustain dry season flow of springs
	Tupicocha, Lima	Peru	dumping stream runoff on rocky slopes to sustain dry season flow of springs
6	Tipon, Cusco	Peru	irrigating upslope agricultural terraces to augment a spring flow
7	Pampachiri, Apurimac	Peru	maintaining a volcanic crater mouth that feed a large perennial spring
	Andamarca, Ayacucho	Peru	Identifying the distant source of a large perennial spring
	Characato, Arequipa	Peru	hosting religious ceremonies to restore a large perennial spring
	San Andres, Chimborazo	Ecuador	long-dormant snow-capped volcano feeding huge perennial springs far away

#### 1. Shepherds' water holes (*cuchacuchas*) in Ayacucho, Peru

Central and Southern Peruvian highlands (above 4000m), when not covered by ice or snow, are generally dry, compared to extensive spongy wetlands (*páramos*) in Northern Andes. Thus, Peruvian pastoralists have a hard time finding sufficient green pasture and water for their animals. Generations of shepherds have tried to overcome this difficulty by artificially creating small ponds, 2 to 12m in diameter and 0.3 to 0.6m deep (Jayo, 2015), wherever they roam with animals year after year. Known in Quechua as *cuchacucha*, these ponds trap runoff from rain or snowmelt, regenerating a patch of grass for the next trip of the herd. While keeping an eye on the animals, the herdsman dig new ponds or clean sediments of old ones using the hand tools they carry.

## SUSTAINABLE GROUNDWATER DEVELOPMENT

### Groundwater Resources & Hydrogeology



Fig. 1 - *Cuchacuchas* at 4300m in Licapa, Paras, Cangallo, Ayacucho (Courtesy of Adripino Jayo)

*Cuchacuchas* served another important purpose: water infiltrating from these ponds fed the springs below high plains. No research has enumerated these, but in certain areas, a hectare may contain hundreds of water holes. Individually, groundwater recharge from a pond may not amount to much, but collectively their contribution is significant. Recent changes to shepherds' lifestyles and to land tenure have reduced the probability of the same person returning yearly to the same location, and thus, these ponds are slowly vanishing from the landscape due to lack of maintenance.

#### 2. Ancestors' ponds in Huamantanga, Lima, Peru

Huamantanga, a district capital in the department of Lima, appears in colonial documents since 1543 (Avila, 2012). The Spanish established the town in the current location, a small plateau (at 3380m elevation) perched in the middle of an otherwise steep slope. The plateau was a prime agricultural land before that. However, this mountainous area has no glacier peaks, nor perennial streams.

Many small ponds (size varying from 20 to 200 m<sup>3</sup>), excavated (2 to 3m deep) in part behind stone masonry walls, dot the slope above Huamantanga. Who built these ponds has not been established archaeologically, but the locals respectfully call them ancestors' ponds (*lagunas de los abuelos*). Canals leading from an intermittent stream fed them long ago, but now all lay abandoned. No canals lead from the ponds, but the elders say small springs at the foot of the slope made feasible agricultural activity in the plateau, before the growing town gobbled up that land.



## SUSTAINABLE GROUNDWATER DEVELOPMENT

### Groundwater Resources & Hydrogeology

Fig. 2 - Feeder canal (on bottom right corner) of Pueblo Viejo pond  
(on top left with little water)

A hydrogeological study mentions that volcanic rock base of the slope above the plateau has some geological fault lines, but estimates that their capacity to store and conduct groundwater is limited (Cotinet, 2014). The study showed that small springs near the plateau have their flow originating from rainfall runoff, not from deeper aquifers. Thus, we propose the hypothesis that water infiltrating from ancestors' ponds travelled down through subsurface soil layers or along the fractures in weathered rock. That also may explain the limited nature of spring outputs, none having a flow greater than 1 liter per second (l/s). Ancestors of Huamantanga must have had to clean pond bottoms frequently to prevent the sediments from blocking infiltration.

It is highly unlikely that the ponds were built under some imperial precolonial patronage. The closest large imperial centers, Pachacamac and Caral, are over 100km away, in the coast, with little influence this high up in the Andes. Being a small village (even now it has only about 300 families), how did Huamantanga mobilize resources to build over a dozen of these ponds?

Irrigation for agriculture has always been a necessity, as rainfall on this western Andean slope is sparse and irregular (average 300+ mm/year). Even if it rains, it does not last more than three months (Cotinet, 2014). Local streams run dry after the rains, making canal irrigation futile. The steep mountain slope does not permit any large storage tank either. Letting the rainwater infiltrate and capturing it at the bottom of the slope is a good, common sense approach. However, the village chief could not simply order his people to build the ponds. If the spring water would not materialize in sufficient quantities after all that hard labor, the chief would lose credibility.

A sacred feature called '*huanca*' -a roughly worked stone pillar erected in the middle of many a pond, apparently modelled after Caral ceremonial complex (Avila, 2012), may give us a clue as to how local authorities would have acted.



Fig. 3 - A pond with a *huanca* (stone pillar) among the aquatic weeds in the middle

Once you adorn a community activity with ritualistic ceremonies, making people associate their religion with it, even if the activity would not produce the expected result, the chief will not face any blame. The burden will rest upon the strength of collective faith. The next time, people can be convinced to perform the ceremonies bigger, displaying stronger belief in what they do. Such situations would rather strengthen the community social organization.

### 3. Infiltration lagoons (*albarradas*) in coastal Ecuador

Thousands of structures similar to Huamantanga ponds appear in Ecuadorean coastal provinces of Santa Elena and Manabi. These U-shaped lagoons (called *albarradas*), at places occupying a few hectares of surface area, retain water behind small earth dams. They date from 2000 BC (Marcos, 2006) and needed only locally available resources to build. The dams are just a few meters tall, so the villagers excavated

## SUSTAINABLE GROUNDWATER DEVELOPMENT

### Groundwater Resources & Hydrogeology

surface soil within the lagoon, piled it up along the downstream perimeter and compacted it manually. They did not build *albarradas* across fast flowing streams, but set them up in gentle slopes where the streams are beginning to form. The open arms of the U-shaped earthen embankment collect the rainwater runoff without the need for feeder canals.

This semiarid region receives rain for only about 4 months a year. The dry air would rapidly evaporate surface water from these shallow lagoons. Therefore, *albarrada* builders usually focused on infiltrating the collected water and capturing the subsurface flow through wells or springs downstream. An extensive study revealed that most old *albarradas* were located above Tablazo geologic formation, a porous marine terrace, raised later by tectonic activity (Marcos, 2006).

Similar to Huamantanga, this region too did not enjoy any State sponsorship to build the lagoons. The village chief would have had to summon the population to build them, convincing each of the benefit of letting the precious liquid infiltrate. However, in these mildly sloping landscapes, the argument that infiltrated water will come out from a spring a short distance downstream and will benefit the same village may not have been that convincing. Probably the chief had better success in telling them that the more lagoons they build, more rain would fall around the village (Pizarro et al, 2013).

Three large *mullo* shells (*Spondylus princeps*), found ritually buried in the dike of *albarrada* Achallan in Santa Elena (Stohtert, 1995) signified a practice common in the Andes: people used them to plead divine agents for more rain (Paulsen, 1974). Again, using rituals during communal activities, the village chief could avoid the blame if the project were to fail.

#### 4. Irrigating the desert in Chan Chan, Trujillo, Peru

From about 850 AD, the Chimú civilization spread along a 1000km stretch of northern coastal Peru. They located the imperial capital at Chan Chan, near the modern city of Trujillo, in the middle of a desert plain slightly sloping towards the sea. Each successive ruler built his own adobe-walled city of about 14ha, with elite residencies containing large fresh water pools, in addition to walk-in water wells for the public. Total urban area, at the arrival of Spanish, had spread over 20km<sup>2</sup>, which included 16 walled cities, pyramids, service and residential areas, as well as huge sunken agricultural fields extending behind the city walls towards the beach. The closest fresh water source, Moche River, flows some 7km away from Chan Chan, but there was no visible water supply route to the city. How did the Chimú serve its huge urban population in this extremely arid climate?



Fig. 4 - Large pool within Tschudi walled city of Chan Chan



Fig. 5 - A sunken agricultural field between the city of Chan Chan and the sea

The Chimú people were masters of irrigation agriculture (Rodríguez, 1970; Ortloff, 1985). In Chan Chan area, they diverted water from Moche River using Vichansao canal (C2 in Fig. 6) and irrigated the vast sandy plains upslope of the city walls. Since Moche flow decreases drastically during some months of the year, they attempted to tap into the more stable flow of Chicama River with the 80km long Intervalle canal (CIV in Fig. 6). A small portion of these plains above Chan Chan is still cultivated, though Trujillo urban area continues to encroach it with buildings.

## SUSTAINABLE GROUNDWATER DEVELOPMENT

### Groundwater Resources & Hydrogeology

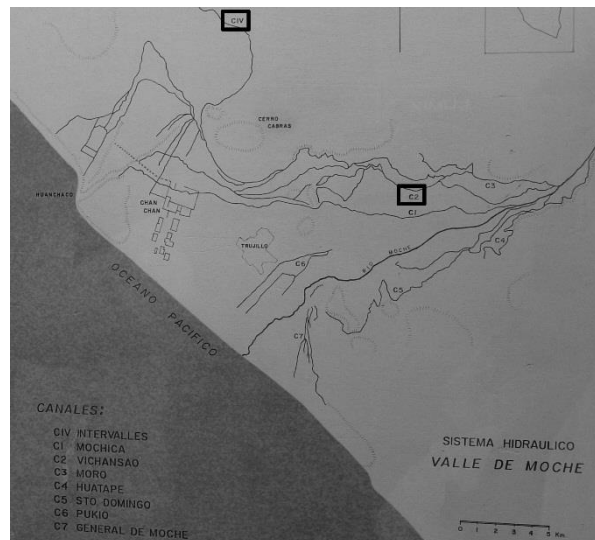

Fig. 6 - Irrigation canals CIV and C2 feeding plains above Chan Chan

(Courtesy of Museo de Chan Chan, Trujillo)

Irrigation water the crops cannot absorb percolates through sandy soil and flows under the city of Chan Chan. By irrigating in excess, they could maintain the groundwater level below the city sufficiently high to feed internal wells, pools and pleasure gardens (Topic and Topic, 1980). Near the coast, fresh groundwater floats above heavier salty water. The Chimu, in order to practice intensive agriculture between the City and the sea, had to lower the planting surface artificially, at places to a depth of 8m (Schjellerup, 2009; Moseley and Feldman, 1984). These sunken gardens, called *huachaqes*, are still in use, though the use of chemicals and pumps by today's farmers cause difficulties.

Unfortunately, archaeological investigations to date have failed to explain how those large pools inside Chan Chan captured groundwater in quantities sufficient to keep their storage fresh and clean. Farmers in *huachaqes* recall seeing, before the archaeological site was cordoned-off, neatly constructed underground drainage conduits coming out of Chan Chan (Gómez, 2015). Further south along the coast, in Nasca, a couple of millennia ago, people had built kilometers-long filtration galleries to capture groundwater for irrigation (Schreiber and Lancho Rojas, 2003). Chan Chan engineers may have used the same technology to feed and drain the city lagoons. In any case, not having a visible water supply route to the city kept their water safe from any enemy attack.

#### 5. Dumping water on rocky slopes in Huamantanga and Tupicocha, Peru

In the same steep Andean slopes above Huamantanga where ancestors' ponds (case #2) are located, a series of earthen canals are visible. They do not lead to the ponds, nor to agricultural fields. Two of these canals, recently rehabilitated, divert water from the main intermittent stream Pachipugro towards weathered granitic rock outcrops, a kilometer or so away. The upper canal begins near point #29 in the image below and one branch ends at #35. The second canal runs parallel to the first, starting from point #28.

## SUSTAINABLE GROUNDWATER DEVELOPMENT

### Groundwater Resources & Hydrogeology

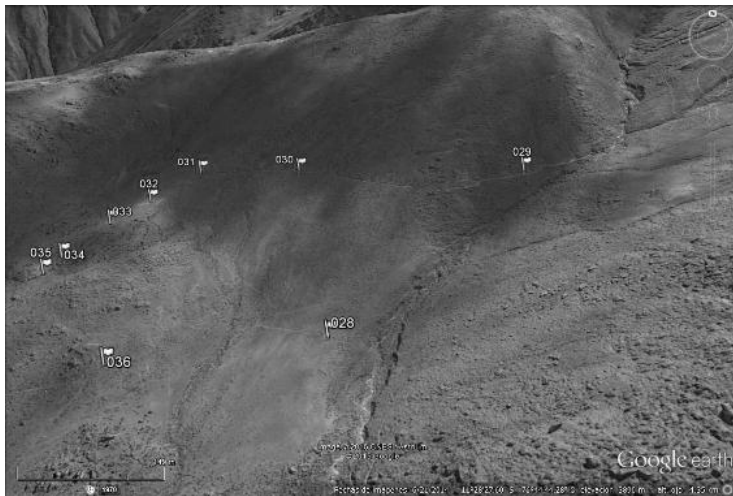

Fig. 7 - Rain runoff diversion canals start near points #28 and #29 from Pachipugro stream

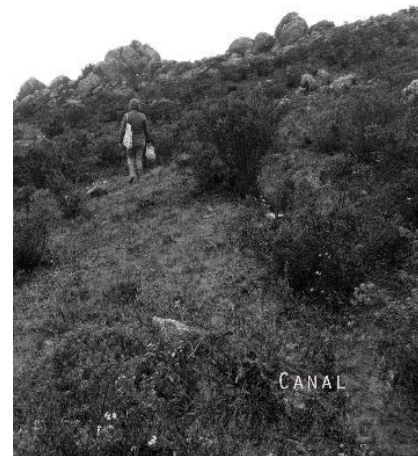

Fig. 8 - Upper canal ends where big weathered boulders occur

Several hundred meters below, at the bottom of a rock escarpment, a couple of springs feed a canal that irrigates farm lots below the town. During the rainy season, when the stream runs full, the irrigators organize themselves to repair and clean the two diversion canals. Saturating the area around the rock outcrop, they attempt to increase the flow of the springs below. They call this process '*mamanteo*', referring to the similarity with breast-feeding.

These two canals, apparently precolonial (according to the villagers), laid abandoned like ancestors' ponds until their rehabilitation in 2013 with the help of two NGOs. The irrigation canal starting from the springs below pertains to a better-organized sector (*allyni*) of the town, capable of mobilizing hard manual labor required for cleaning the diversion canals. Decades-long wave of migration to Lima probably debilitated the community organization in Huamantanga, causing the abandonment of those canals. Recent, drastic dry spells combined with uncontrolled pasturing in the upper catchment have severely reduced the irrigation water supply, forcing the farmers to revert to the ancient practice of recharging spring flows.

Even though the volcanic base rock is said to have low permeability (Cotinet, 2014) large weathered boulders in recharging area may provide decent seepage paths. One of the NGOs, CONDESAN, indicates that first '*mamanteo*' water flows appeared in the springs 3 to 4 weeks after recharging started. Pachipugro stream dries out soon after the rains end. Thus, the longer the delay between recharging and its emergence in springs, the better for the farmers, as they can irrigate deeper into the dry season. CONDESAN (2015) expects the irrigation canal to capture up to 40% of recharged water. It has launched an experiment in parallel, to check whether conserving the upstream vegetation cover would prolong the stream runoff.

San Andrés de Tupicocha (Province of Huarochiri, Department of Lima), an Andean community located 64km SE of Huamantanga at about the same altitude, has been continuing a precolonial groundwater recharging technique. Until the 1990s, together with a few neighboring communities, it maintained many rainfall runoff diversion canals that benefitted all of them with decent increases in spring flows. The hard labor involved in the annual cleaning of these long canals and the heavy migration of inhabitants to Lima forced the other communities to withdraw.

Since Inca days, Tupicocha maintains its communal land-holding tradition and a social organization based on family ties (*parcialidades* or *allyni*) (Salomon, 2006). Each of its ten *parcialidades* provides, proportionately to the rights each holds, the manual labor required for the community work. These traditions run so deep that, till early twentieth century, the community work completed and the labor expended were all registered in the *kipu* (Inca node-based system of accounting) pertaining to each *parcialidad* (Salomon, 2006). Therefore, Tupicocha has not faced difficulties in continuing its canal-maintenance festival, embedded with rituals, accompanied by ceremonial music and dancing.

## SUSTAINABLE GROUNDWATER DEVELOPMENT

### Groundwater Resources & Hydrogeology



Fig. 9 - The end of a feeder canal  
in Tupicocha

A basic hydrogeological investigation (Apaza et al, 2006) indicated that the fractures in the base rock of the sloping area are not open enough to facilitate rapid and large subsurface water flows. The biggest spring in the area has a flow rate around 5 l/s and the rest, flows much smaller. After the initial water infiltration, the flow in a spring some 1000m below would begin to increase in about a couple of months (Apaza et al, 2006). Therefore, it is likely that the subsurface flow occurs mainly through the thin soil layer and the fractured and decomposed rocks immediately below. This recharge mechanism is quite similar to '*mamanteo*' of Huamantanga, even though it is known as '*amunda*' in Tupicocha.

#### 6. Perennial water spring in a terraced-agriculture and ceremonial site in Tipón, Peru

Tipón, a 240-hectare archaeological site 27km east of Cuzco, is best known for its Inca ceremonial complex. It includes elite residences, temples and an elaborately built terraced water garden centered on a perennial spring, all circumscribed by a huge rock wall. This large site also contains 100 ha of roughly built agricultural terraces, some of which date prior to Inca period (Wright et al, 2001).



Fig. 10 - Tipón with its terraces (main plaza at bottom left) and the  
irrigation canal (darker line)

This area receives, on average, 800mm of rain annually. During the Inca period, canals diverted water from Rio Pukara, at the top edge of the land (3690m elevation), to irrigate about half of the agricultural terraces, in addition to supplying water for ritual and domestic purposes. The main irrigation canal has the capacity to deliver a flow close to 100 l/s, but Rio Pukara in dry season carried only 22 l/s (Wright et al, 2001). During the last few decades, this canal has stayed dry, as agricultural activities are no longer permitted within the site. Currently, the Inca water garden, located near the bottom edge of the site, is fed



## SUSTAINABLE GROUNDWATER DEVELOPMENT

### Groundwater Resources & Hydrogeology

only from its water spring (at 3448m elevation) on the third garden-terrace from the top, whose output was measured at 18 l/s during the dry season (Wright et al, 2001).

Since Tipon spring's drainage basin is only 64 ha and the average rainfall is also low, how does it produce such a high water flow? In contrast, Rio Pukara drains 340 ha and its flow isn't any bigger. The mountain range, on whose slope sits the site of Tipon, rises to 4000m elevation, but has no permanent snowcap. Nor are there any lagoons on top of the range that could feed the spring perennially.

For intensive cultivation in Inca times, 50+ ha of terraces fed by the irrigation canal required much more water than Pukara river's dry season flow (Wright et al, 2001). Thus, the Inca had to divert rainy season river flow, using a large-sized canal, and store the excess moisture in terraced fields for later use. This excess water storage in well-draining terrace soils would have generated a lot of seepage towards the spring directly below, increasing its flow substantially. The large carrying capacities of water distribution canals below the spring support this hypothesis. Excavations at the spring also revealed a very elaborate effort by the Inca to collect groundwater from every possible direction, using seven different underground conduits (Wright et al, 2001).

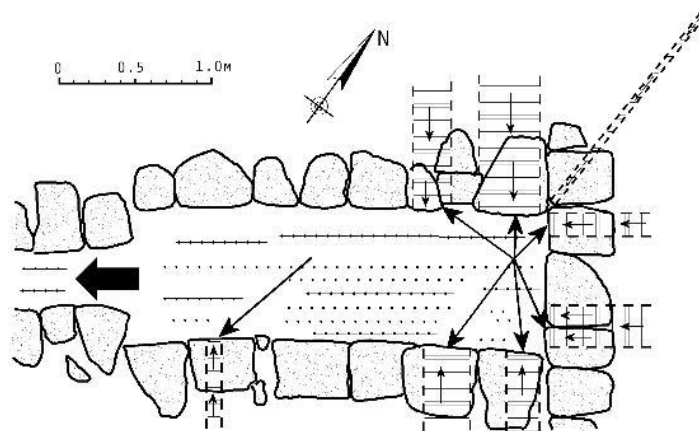

Fig. 11 - The collector conduits feeding Tipon spring (from Wright et al, 2001); the thickest arrow shows spring outflow; mid-sized arrows indicate 7 feeder conduits; small arrows in each feeder conduit indicate its flow direction

In addition, Wright and others (2001) propose that long fissures in volcanic rock base above the spring may increase its drainage basin. The Cruzmoco peak, lying some 2km behind the spring at the top of the range, forms a part of a long dormant volcano (Hostnig and Carreño, 2007). Andean volcanoes, uplifted through subduction tectonic movements, when active, tend to accumulate inside huge quantities of water at high pressure and temperature (Shiina et al, 2013). These high pore pressures and temperatures break internal rock walls of the volcanic cone, creating large open spaces inside (Day, 1996; Farquharson et al, 2015; Farquharson et al, 2016). In Japan, springs located around this type of dormant volcanoes continuously emit substantial water flows, and the scientists posit that long rock fractures may connect those springs with large internal water storage (Asai et al, 2009). This situation may explain, at least partially, the high flows of Tipon spring, even during times of low rainfall, no snow cover and no irrigation above it.

### 7. Large spring flows in volcanic mountain flanks

Apart from many small springs that quench rural populations, Andean mountains have dotted the South American landscape with a few privileged locations where some springs emit flows over hundreds of liters per second. Pumapuquio spring, located in the district capital Pampachiri (Department of Apurimac, Peru) is one of those.

## SUSTAINABLE GROUNDWATER DEVELOPMENT

### Groundwater Resources & Hydrogeology



Fig. 12 - Pumapuquio spring, with flow rates varying from 50 to 300 l/s



Fig. 13 - 'Mouth' of the earth-filled volcanic crater which feeds Pumapuquio spring

The local population has identified a large, earth-filled, ancient volcanic crater lake, some 4km away from the spring and 300+m above, as the origin of this water. During several months of the year, a small depression in the middle of the crater swallows rain and snowmelt runoff through a rocky opening. The spring flow varies through the year, and may drop to 50 l/s in drier months (Jayo, 2015). The local farmers annually make the trip up the hill to direct the runoff towards the depression in the crater and clean its 'mouth' to prevent the sediments from blocking it.

A similar spring, albeit with a lower flow rate, is located within the agricultural terraces of the community of Andamarca (District of Carmen Salcedo, Department of Ayacucho, Peru). The closest mountain range, at a 6km distance, has small lagoons and its volcanic peaks are occasionally snow-capped. The villagers often recite a legend (UNDP, 2013) which explains how they identified the origin of their spring, emptying tiny *quinua* seeds into a lagoon.



Fig 14. - Andamarca spring had a flow rate in excess of 40 l/s

A few km off the Peruvian desert city of Arequipa, in Cerillo (District of Characato), a spring provides 200+ l/s of irrigation water for the farmers in the area. The only possible sources of this water, the volcanic peaks Mismi and Pichu-Pichu, are located some 20km away from the spring.

## SUSTAINABLE GROUNDWATER DEVELOPMENT

### Groundwater Resources & Hydrogeology



Fig. 15. - *Ojo del milagro* spring with Mismi peak to the north and Pichu-Pichu to the east

According to the farmers, not many years ago, the spring dried out almost completely. After a series of ritualistic ceremonies and many pleas to their deities, the groundwater flow was restored, which gave rise to its name '*Ojo del Milagro*' (eye of the miracle).

Some 15 to 20km away from the snowy peak of 6300m high Chimborazo volcano in Ecuador, three large springs (*manantiales*) are found. Two of them emit close to 100 l/s of irrigation water and the other, at Lillo, supplies the provincial capital Riobamba with 300+ l/s. A 30km long, ancient lava flow from the volcano outcrops as a small ridge containing large blocks of basalt, and the springs appear either side of this ridge.



Fig 16. - Three springs with large flows at the foot of Chimborazo volcano, near Riobamba, Ecuador

Since no lakes or perennial streams appear along this flank of Chimborazo, glaciers may be the only visible source for this spring water. With the ever-diminishing snowcap, some water users say that spring flows also have diminished by 10-20% over the last 20 years. Indigenous communities in Chimborazo region were famous for their rituals celebrating this white giant and its gift of water (Moya, 1981) but the current beneficiaries of these springs have no memory of such ceremonies.

No detailed hydrogeological studies exist for any of these Andean large springs. The precipitation levels may range from 50mm to 400mm per year in these locations, though slightly higher values can be expected at mountain peaks. The rain and snowmelt runoff alone cannot explain the high flow values at these springs. In Andamarca, some lagoons are present at higher altitudes, but their small storage cannot feed such flows continuously. Since these spring waters are generally cooler than even the ambient temperature, we have to discard any geothermal emissions contributing to them. Therefore, the only

## SUSTAINABLE GROUNDWATER DEVELOPMENT

### Groundwater Resources & Hydrogeology

plausible explanation for these large spring flows reside in the phenomena we described in the case of Tipon spring. That is, the springs must be connected through wide-open, long rock fractures to large storages of water inside the dormant Andean volcanoes nearby.

The communities of Pampachiri and Andamarca identify their springs as *amunas* or *millpu*. As we discussed before, the small springs in San Andrés de Tupicocha, fed through near-surface groundwater movements, are also known as *amunas*. To avoid any misunderstandings, and to differentiate between these two very distinct groundwater movements, we suggest using the name '*millpu*' to refer to all volcano-associated springs with high flow rates.

#### Discussion, Conclusions and Recommendations:

The examples cited above demonstrate various ancestral practices employed by governing regimes and communities in the Americas to ensure sufficient groundwater supplies for their inhabitants. In some cases, they have ingeniously employed technologies intended for improving agricultural production to augment groundwater recharge indirectly. In other situations, the communities have organized themselves, mostly without any State help, to build specific structures to increase the groundwater flow.

To design such recharge systems, ancient community leaders had to have a good understanding of the local hydrogeology. As some case studies showed, they succeeded in providing solutions for the population even in situations where modern scientists had expressed doubts. That proves the value of detailed, long-term observations coupled with trial and error methods because geological conditions could vary in a scale of meters at tectonically altered locations.

By promoting this type of ancestral technologies, many rural communities today will be able to augment their groundwater resources without depending on external help. Unfortunately, little systematic work has been done to unearth such ancestral knowledge. Even in archaeologically important sites, ancestral use of groundwater sources has not received the attention it deserves.

After constructing groundwater recharge systems, the communities expect direct benefits to their water supply sources. However, even to this day, estimating when and what percentage of naturally or artificially infiltrated water will find its way to a particular spring or a well is a tough task, riddled with many uncertainties.

In extremely arid, Amargosa River near Death Valley, California, USA, natural recharging process of its mid valley alluvial deposits was studied using borehole data and flow gauges (Stonestrom et al, 2004). They estimated that 12 to 15% of the amount infiltrated from the riverbed continued towards the water table. In comparison, agricultural sites in the valley, irrigated using sprinklers, allowed 8 to 16% of that water to percolate deep. They further found that flat shrub-covered lands, away from stream channels, contributed hardly any water as recharge. The time to recharge, for infiltrated water to reach 100m deep water table under the riverbed, estimated by Stonestrom et al (2004) as 225 to 475 years, is strongly contested. Flint et al (2004) suggested that, in arid environments, time for deep percolation might vary from years to days, depending on climatic conditions.

In humid climates, where evapotranspiration is less than precipitation, deep percolation is continuous as gravity can easily overcome suction forces created by evapotranspiration activity. However, under arid conditions, where evapotranspiration is much greater and infiltrating flows are minimal, suction and capillary forces dominate the unsaturated soil zone. Nevertheless, in any locality, humid and arid subterranean conditions swap, depending on the climate prevailing at a given time. Furthermore, those conditions differ with the location too, depending on the source of infiltration. Beneath a saturated agricultural terrace or a temporary lake, we should consider that conditions akin to a humid climate would prevail and calculate percolation rates accordingly. Many other hydrogeological situations may complicate these calculations as well.

Crerar et al (1988) reported that instrumented Swakop River middle valley in western Namibia showed flash floods recharging its shallow alluvial deposits in just a few hours. However, when the flood velocity became slow enough to deposit a silt layer on the riverbed, recharge decreased to almost zero. When water percolating through permeable deposits encounter preferred pathways, such as open fractures in otherwise impermeable rock layers, recharge time calculations become very complex (Balek, 1988). Van der Sommen and Geirnaert (1988) studied the aquifer system in West African Shield, extending south from Niger to Ghana, which consists of two components: hard rock with fractures and the weathered

## SUSTAINABLE GROUNDWATER DEVELOPMENT

### Groundwater Resources & Hydrogeology

mantle above it. Initially this aquifer was considered as a series of discontinuous blocks of water, but further drilling revealed a large regional recharge-discharge system.

Since rural communities have no access to sophisticated equipment to disentangle all these complications in groundwater recharge, it is worthwhile analyzing the strategy used by ancestral village leaders to mobilize community labor to do hydraulic works, without sacrificing their credibility in case of a failure. The employment of ceremonies and appeals to the deities during such community works moves that risk away from the political leadership. The foremost blame for the failure of a project, if it happens, would fall upon the lack of collective faith. The most logical next step would be to conduct the next project with stronger religious fervor so that the deities would hear the pleas.

Many of the techniques and the concepts described above are valid for today. Once the basics are understood, the techniques need to be modified and adapted to the local conditions, before employing them in a community under serious water stress. However, instead of seeking piecemeal repairs to specific issues, community leaders need to look at the problem from a holistic point of view to find a solution socially, technically, economically and environmentally compatible with locally available resources.

#### Acknowledgements:

This work is the result of our 30+ years of immersion in the Americas. We are deeply indebted to thousands of friends who helped us with travelling, volunteer work and research that enriched our knowledge. We apologize for the lack of space to acknowledge every one and send a big thank you to all.

#### References:

- Apaza Idme, Dimas, et al (2006) "Las amunas de Huarochiri: recarga de acuíferos en los Andes", GSAAC, Lima. <http://www.agua-c.org/amunas.pdf>
- Avila C., Jorge (2012) " El sistema de infiltración hídrica para el mamanteo de Huamantanga", ONG Alternativa y Municipalidad Distrital de Huamantanga, Julio.
- Asai, Kazuyoshi et al (2009) "Isotopic approach to understanding the groundwater flow system within an andesitic stratovolcano in a temperate humid region: case study of Ontake volcano, central Japan", Hydrological Processes, volume 23, Issue 4, pages 559–571, February.
- Balek, J. (1988) "Groundwater recharge concepts", in Simmers, Ian, "Estimation of Natural Groundwater Recharge", Ed., NATO Advanced Research Workshop on Estimation of Natural Recharge of Groundwater held in 1987, Antalya, Turkey, Springer Science+Business Media, Dordrecht, Holland, pp 3-10.
- CONDESAN Consorcio para el Desarrollo Sostenible de la Ecorregión Andina (2015) comunicaciones del e-Foro "Crianza del Agua: Experiencias en la región Andina", <http://www.infoandina.org/es/crianza-agua-experiencias-region-andina>, Lima, Peru.
- Cotinet, Rémy (2014) "Estudio hidrogeológico preliminar de un sistema acondicionado: Los Mamanteos de Huamantanga, Perú", tesis de maestría, Université d'Avignon, Francia.
- Crerar, S. et al (1988) "An unexpected factor affecting recharge from ephemeral river flow in SWA/Namibia", in Simmers, Ian, "Estimation of Natural Groundwater Recharge", Ed., NATO Advanced Research Workshop on Estimation of Natural Recharge of Groundwater held in 1987, Antalya, Turkey, Springer Science+Business Media, Dordrecht, Holland, pp 11-28.
- Day, S. J. (1996) "Hydrothermal pore fluid pressure and the stability of porous, permeable volcanoes", Geological Society, London, Special Publications, v. 110, p. 77-93.
- Farquharson, Jamie, et al (2016) "Pore pressure embrittlement in a volcanic edifice", Bulletin of Volcanology, 78:6, Springer-Verlag, Berlin, January.
- Farquharson, Jamie, et al (2015) "Permeability and porosity relationships of edifice-forming andesites: a combined field and laboratory study", Journal of Volcanology and Geothermal Research, 297:52–68.
- Flint, Alan L., et al (2004) "Fundamental Concepts of Recharge in the Desert Southwest: A Regional Modeling Perspective", in "Groundwater Recharge in a Desert Environment: The Southwestern United States", Hogan, James, F., et al, Eds., Water Science and Application 9, American Geophysical Union, pp 156-184.
- Gómez P., Félix (2015) Personal communication, Trujillo, Peru.

## SUSTAINABLE GROUNDWATER DEVELOPMENT

### Groundwater Resources & Hydrogeology

- Hostnig, Rainer and Carreño Collatupa, Raúl (2007) "Petroglifos y litograbados de Cruzmoqo, Tipón, Cusco" Boletín de Museo de Arqueología, Antropología e Historia, Universidad Nacional de Trujillo, Facultad de Ciencias Sociales, N° 10, Peru.
- Jayo, Adripino (2015) Communication to e-Forum 'Crianza de Agua' organized by CONDESAN, Lima, Perú, September.
- Marcos, Jorge G. (2006) "Water management in ancient Ecuador", in 'From where life flows: the local knowledge and politics of water in the Andes', Ed: Jacobson, Frode F. and John McNeish, Tapir Academic Press, Trondheim, Norway, pp 41-52.
- Moseley, Michael E and Robert A Feldman (1984) "Hydrological dynamics and the evolution of field form and use: resolving the knapp-smith controversy" American Antiquity 49(2): pp 403-408.
- Moya, Ruth (1981) "Simbolismo y ritual en el Ecuador andino y el quichua en el español de Quito", Pendoneros #40, Instituto Otavaleño de Antropología, Otavalo, Ecuador.
- Ortloff, Charles R. (1985) "La ingeniería hidráulica chimú" in La tecnología en el mundo andino, ed: Heather Lechtman y Ana Maria Soldi, UNAM, Mexico, pp 91-134.
- Paulsen, Allison C. (1974) "The thorny oyster and the voice of god: Spondylus and Strombus in Andean prehistory", American Antiquity, 39(4), pp 597-607.
- Pizarro, Roberto, et al (2013) "Inland water bodies in Chile can locally increase rainfall intensity", Journal of Hydrology, 481, pp 56-63.
- Rodriguez Suy Suy, Victor (1970) "Irrigación prehistórica en el Valle de Moche", XXXIX International Congress of Americanists, Lima.
- Salomon, Frank (2006) "Los Quipocamayos: El antiguo arte del khipu en una comunidad campesina moderna", Institut français d'études andines, Lima, <http://books.openedition.org/ifea/5355>
- Schjellerup, Inge R. (2009) "Sunken fields in the desert of Peru" The Egyptian journal of environmental change, vol 1:1, pp 25-33, Oct. <http://www.envegypt.com/EJEC/uploads/30.pdf>
- Schreiber Katharina and Josué Lancho Rojas (2003) "Irrigation and the society in the Peruvian desert: the puquios of nasca", Lexington Books, UK.
- Shiina, T. (2013) "Seismic evidence for high pore pressures in the oceanic crust: implications for fluid-related embrittlement", Geophysics Research Letters, 40(10):2006–2010.
- Stonestrom, David A., et al (2004) "Tectonic, Climatic, and Land-Use Controls on Groundwater Recharge in an Arid Alluvial Basin: Amargosa Desert, U.S.A." in "Groundwater Recharge in a Desert Environment: The Southwestern United States", Hogan, James, F., et al, Eds., Water Science and Application 9, American Geophysical Union, pp 29-48.
- Stohtert, Karen, (1995) "Las albarradas tradicionales y el manejo de aguas en la Península de Santa Elena", Miscelánea Antropológica Ecuatoriana, Boletín del Área Cultural del Banco Central del Ecuador, 8:131-160, Guayaquil.
- Topic, Theresa L and John R. Topic (1980) "Arquitectura en Chan Chan" en Chan Chan: Chimú Metropoli, ed: Rogger Ravines, Institute de Estudios Peruanos, Lima, Perú.
- UNDP United Nations Development Programme (2013) "Amunas - Andenes", <https://www.youtube.com/watch?v=jAM7s8HeZag>, Quito, Ecuador.
- van der Sommen, J.J., and W. Geirnaert (1988) "On the continuity of aquifer systems on the crystalline basement of Burkina Faso", in Simmers, Ian, "Estimation of Natural Groundwater Recharge", Ed., NATO Advanced Research Workshop on Estimation of Natural Recharge of Groundwater held in 1987, Antalya, Turkey, Springer Science+Business Media, Dordrecht, Holland, pp 29-48.
- Wright, Kenneth R., et al (2001) "Tipon water engineering: masterpiece of the Inca empire", Final Report No344-INC-C-2000, Wright Paleohydrological Institute, Denver, Colorado, USA, April.

## SUSTAINABLE SERVICES

### Rural Water Supply Sustainability

## 3.3 SUSTAINABLE SERVICES

### 3.3.1 Rural Water Supply Sustainability

---

## Searching for sustainability of rural water supply: a snapshot of perspectives of 14 countries across Asia

---

Type: Long Paper (up to 6,000 words)

**Authors:** Susanna Smets, The World Bank; Sean Furey, Skat Foundation; Antoinette Kome, SNV, Almud Weitz, The World Bank

#### Abstract/Summary

The World Bank’s Water Global Practice in partnership with the Netherlands Development Organisation (SNV), WaterAid and Rural Water Supply Network (RWSN), organized a 2.5-day pan-Asian learning event on sustainability of service delivery in rural water supply. A total of 56 participants from 14 countries in East Asia and Pacific, South Asia and Central Asia participated, including Bangladesh, Cambodia, China, Indonesia, India (3 states, Uttarakhand, Punjab, Assam), Kyrgyzstan, Lao Peoples’ Democratic Republic (PDR), Myanmar, Nepal, Pakistan, Papua New Guinea, the Philippines, Timor-Leste and Vietnam. Most participants were representatives of the lead national or state agency responsible for rural water supply in their country. The learning event discussed the importance of a service delivery approach for sustainable rural water supply, appreciating the complementary roles of actors at different levels: service providers, service authorities (local / sub-national governments) as well as national or state institutions, critical for the improvement and expansion of rural water services. Key themes were explored in detail, such as:

- i. service provider management models and post-construction support services
- ii. sustainable financing arrangements
- iii. economic regulation and pro-poor approaches
- iv. monitoring and social accountability

In this article we are sharing the main findings and insights from this event. Sustainability of services is clearly on the radar among Asian countries, and many have seen significant positive developments in recent years, with the large majority having met their Millennium Development Goal (MDG) for water supply. However, progress towards sustainable service delivery is uneven, with some countries performing better than others, and certain themes receiving more attention than others. Positive developments are the higher priority for rural water supply translating into higher budget allocations, an emerging focus on piped services and household connections (though varying greatly across countries), and an increased understanding and focus on institutional aspects important for sustainability. However, common challenges, underpinning the lack of sustainable service provision remain, such as inadequate financing, including low recovery from tariffs, negligence of direct support and major repair costs. Also, limited human resources, recurrent capacity development needs, combined with poor asset management and the absence of technical support systems are undermining sustainability. Finally, the rising challenge of water scarcity and droughts is putting increasing pressure on water supplies in the region, especially for the most vulnerable and poor populations that often still rely on improved sources.

The road to achieve a sustainable service delivery approach is long, complex and very country- and context- specific, for example in the areas of financing, asset management, monitoring, regulation, professionalization and private sector participation. While a great deal of innovation is happening in the region, the results have often not yet been shared and adapted in order to operationalize them into

## SUSTAINABLE SERVICES

### Rural Water Supply Sustainability

holistic sustainable approaches for different country contexts. The learning event has helped to share innovations and experiences to facilitate joint critical reflection and create new insights for governments and other stakeholders, bringing different parts of the puzzle together. While awareness on the bottlenecks is high and opportunities for mutual learning abound, more emphasis on practical learning is required going forward. Similar to how stakeholders have successfully facilitated learning on rural sanitation over the past seven years in Asia, regional learning on rural water supply could enhance country activities and help them make faster progress towards sustainable service delivery models for their contexts.

## INTRODUCTION

From 10-12 May 2016, a learning event was held in Bangkok on Sustainable Rural Water Supply Services. The event was organized by the World Bank's Global Water Practice, WaterAid, SNV and RWSN. A total of 56 people participated from 14 countries in the greater Asia Pacific Region: Bangladesh, Cambodia, China, Indonesia, India (3 states, Uttarakhand, Punjab, Assam), Kyrgyzstan, Lao PDR, Myanmar, Nepal, Pakistan, Papua New Guinea, Philippines, Timor-Leste and Vietnam (plus a delegation from Thailand, the host). The majority of participants were senior government officials from ministries of water supply and sanitation, rural development, and public health; water resources; and national planning and monitoring; or from project management units (PMUs) of World Bank projects in these relevant sector ministries.

This paper summarizes the main thematic findings and lessons that emerged, providing a snapshot of the state of rural water supply across Asia. Due to the broad scope of issues covered at this event a literature review has not been attempted, however, further background resources can be found at World Bank, SNV, WaterAid and RWSN websites (see references). While the majority of countries achieved the MDGs, and half of the countries are at, or near, universal access in rural areas for improved water supply (>90 percent), the new Sustainable Development Goal (SDG) to “Ensure access to water and sanitation for all” casts these achievements in a different light, with targets around universal and equitable access to services, but also addressing quality, water resource management, and cooperation. Rural access to piped water is below 10 percent for the other half of these Asian countries. In the face of increasing water security challenges, governments will need to look beyond increasing access only, towards sustaining and improving service levels and quality.

The aim of the event was to support participants to think about possible solutions for the sustainability of service provision in their countries through sharing of experiences and critical reflections. Moreover, the event aimed to contribute to the 7<sup>th</sup> RWSN forum with knowledge, good practices and lessons learned from Asia.

## SETTING THE STAGE

### From Millennium Development Goals to Sustainable Development Goals

Although the wider Asia region is extremely diverse, there are some overall trends occurring in the region. Asia is the most populous region in the world. It has been characterised in recent decades by high population growth, urbanization, and unprecedented economic growth, coupled with equally unprecedented poverty reduction for the region. As illustrated in Table 1, the overwhelming majority of countries participating in this learning event met the Millennium Development Goal target of halving the number of people without access to an improved water source. Pakistan and Timor Leste made “Good Progress”, while Papua New Guinea (PNG) made “Limited or No Progress” and is ranked as having the fourth lowest rural water coverage worldwide. Overall, progress has been positive for this group of Asian countries, with dramatic increases in access to improved rural water sources both in absolute population terms and proportion of the rural population, as shown in Table 2. Across the 15 countries (including Thailand) an estimated 1.88 billion rural people now have access to an improved water source, up from 1.21 billion in 1990, while those without access to an improved source declined from 0.77 to 0.19 billion. Yet, behind these numbers are major concerns about the quality and safety of water from ‘improved water sources’ and the sustainability of rural water services, in terms of water resources and life cycle financing.



## SUSTAINABLE SERVICES

### Rural Water Supply Sustainability

Now the global community is in the Sustainable Development Goal (SDG) period from 2015-2030, and the SGD target 6.1 (i.e. “by 2030, achieve universal and equitable access to safe and affordable drinking water for all” (UN 2015)) raises the bar of what service levels needs to be achieved and monitored, emphasizing reliable access, proximity to the house, and the safety and affordability of the water supply

**Table 1: JMP figures for rural water access in 2015 (WHO-UNICEF, 2016)**

Country	Total Improved Rural Water Access 2015 (%)	Rural Piped Access 2015 (%)	Met MDG target?	Proportion of the 2015 population that gained access since 1990 (%)
Bangladesh	87.0	1.1	Met target	41
Cambodia	69.1	7.3	Met target	62
China	93.0	55.4	Met target	40
India	92.6	15.7	Met target	46
Indonesia	79.5	9.4	Met target	39
Kyrgyzstan	86.2	41.8	Met target	32
Lao PDR	69.4	6.0	Met target	
Myanmar	74.4	2.7	Met target	35
Nepal	91.8	18.2	Met target	50
Pakistan	89.9	24.9	Good progress	40
Papua New Guinea	32.8		Limited or no progress	22
Philippines	90.3	30.4	Met target	41
Thailand	98.0	37.0	Met target	24
Timor Leste	60.5	14.3	Good progress	
Vietnam	96.9	10.0	Met target	51
<b>TOTAL</b>	<b>91.0</b>	<b>27.4</b>	<b>Met target</b>	<b>42</b>

**Table 2: JMP figures for rural water access in 1990 and 2015 for countries listed in Table 1**

Year	Total Population (million)	Rural population with improved water access (million)	Total Improved (%)	Rural population with water piped on Premises (million)	Piped on Premises (%)
1990	2,702	1,210	61.1	150	7.4
2015	3,670	1,880	91.0	570	27.4

### Raising the Bar from Millennium Development Goals to Sustainable Development Goals

The overall theme of the learning event was how to move from an infrastructure-centric approach to a focus on developing systems that support the sustainability of rural water service provision in support of the Sustainable Development Goals. This means changing the unit of intervention from individual schemes to addressing sustained access to water supply services in an entire administrative area, e.g. district. Sustainability means that a system is in place at the level of the service authority, say the district level, that ensures that all schemes within the district’s jurisdiction are repaired in a timely manner, upgraded or replaced, as a result of functioning systems for support, oversight, financial services, and social accountability.

Adapted from the Triple-S programme (IRC, 2014), the World Bank is currently testing an emerging framework for sustainability in 16 countries that encompasses three geographic scales:

- i) national/sector level (or state level)
- ii) level of service authority, often local government (e.g. district)
- iii) service provider level, where various management models exist

## SUSTAINABLE SERVICES

### Rural Water Supply Sustainability

Different country contexts can have multiple levels dictated by their administrative arrangements. The service delivery model will be shaped by important factors in the country’s context and sector governance environment. At service provider level, various **management models** can exist, which do not operate in isolation from the roles and responsibilities allocated to local and national levels. Also, in any given country (or federal state), multiple management models will be in existence and each operate with different support needs. These service provider models can be grouped in following categories (with hybrid options):

- i) community-based management models,
- ii) direct local government provision
- iii) public utility provision
- iv) private sector models along the spectrum of public-private partnerships
- v) supported self supply

Despite the inherent diversity of real world service delivery, key components, or building blocks, are required for the service delivery model to operate sustainably, and thus to deliver sustained water supply services: namely:

- i) **institutional capacities** at all level, including post-construction support services
- ii) **financing** of the sector, including affordability issues and equity
- iii) **asset management**, e.g. arrangements to ensure capital maintenance
- iv) **water resource management**
- v) **monitoring and regulation**

## INSIGHTS FROM THE LEARNING EVENT

### There is an opportunity to capitalise more on the positive changes

In general, the following **positive changes** were happening in a number of countries:

- i) higher priority for rural water supply is translating in some countries into more funding
- ii) emerging focus on providing piped services and household connections
- iii) increased understanding and focus on institutional aspects: e.g. post-construction support, major repair provisions, and monitoring systems

However, **common challenges**, underpinning the lack of sustainable service provision were:

- i) insufficient financing, especially due to low tariffs
- ii) limited human resources and capacity development needs
- iii) water scarcity and security undermining sustainability
- iv) poor asset management and back-up support systems
- v) challenges with last mile service delivery to vulnerable groups/poor

There are tremendous opportunities to capitalise more on these positive changes within countries and in neighbouring countries and learn proactively from experiences in the region.

Table 3 illustrates further country team reflections on challenges and positive changes over the last three to five years, illustrating the different levels of sector development among the participating countries.

**Table 3: Reported challenges and positive changes by country teams**

Country	Challenges	Positive change
Bangladesh	<ul style="list-style-type: none"> <li>• Lack of institutional capacity to backstop sustainable Operations &amp; Maintenance (O&amp;M)</li> <li>• Not well developed private sector</li> </ul>	<ul style="list-style-type: none"> <li>• Large-scale water quality monitoring and focus on arsenic management</li> </ul>

## SUSTAINABLE SERVICES

### Rural Water Supply Sustainability

Country	Challenges	Positive change
<b>Cambodia</b>	<ul style="list-style-type: none"> <li>• Sustainability lacking of community service providers</li> </ul>	<ul style="list-style-type: none"> <li>• Promotion of piped water systems in rural areas (not just point-source solutions)</li> </ul>
<b>China</b>	<ul style="list-style-type: none"> <li>• Asset management, especially for capital maintenance to improve sustainability</li> </ul>	<ul style="list-style-type: none"> <li>• Transition to piped water systems</li> </ul>
<b>India</b>	<ul style="list-style-type: none"> <li>• Water resources sustainability issues</li> </ul>	<ul style="list-style-type: none"> <li>• Recent gains in improved access</li> <li>• Focusing on 100% house connections</li> </ul>
<b>Indonesia</b>	<ul style="list-style-type: none"> <li>• Human resource capacities required for scale-up</li> <li>• Financing, especially on tariffs</li> </ul>	<ul style="list-style-type: none"> <li>• Incentive mechanisms for good performance</li> <li>• Increased govt. investments</li> </ul>
<b>Kyrgyzstan</b>	<ul style="list-style-type: none"> <li>• Local institutional capacities weak</li> <li>• Low tariffs and financing gaps</li> </ul>	<ul style="list-style-type: none"> <li>• National water supply policy (2013)</li> <li>• Water supply development strategy (2016) with targets</li> </ul>
<b>Lao PDR</b>	<ul style="list-style-type: none"> <li>• Lack of sustainability of systems</li> <li>• Water quality management of point sources</li> </ul>	<ul style="list-style-type: none"> <li>• Move towards household connections (not yet reaching remote rural)</li> </ul>
<b>Myanmar</b>	<ul style="list-style-type: none"> <li>• Huge financing needs</li> <li>• Absorptive capacity of providers</li> <li>• Limited human resources</li> <li>• No regulation</li> </ul>	<ul style="list-style-type: none"> <li>• Better budget allocation process</li> </ul>
<b>Nepal</b>	<ul style="list-style-type: none"> <li>• No standardized indicators for monitoring functionality</li> <li>• Water quality management</li> </ul>	<ul style="list-style-type: none"> <li>• Increased prioritization by govt.</li> <li>• Combined water and electricity</li> <li>• Monitoring systems for functionality</li> </ul>
<b>Pakistan</b>	<ul style="list-style-type: none"> <li>• Finding appropriate management models to guarantee sustainability,</li> <li>• Ways to increase private sector involvement</li> </ul>	<ul style="list-style-type: none"> <li>• Financial govt. support for major repairs to communities</li> <li>• Increased budget allocation</li> <li>• Monitoring of services using Information Communications Technology (ICT)</li> <li>• Integrated approach for urban and rural by state utility</li> </ul>
<b>Philippines</b>	<ul style="list-style-type: none"> <li>• Water resources sustainability and disaster risk</li> </ul>	<ul style="list-style-type: none"> <li>• Use of experts to help small utilities improve performance</li> <li>• Capacity building and grant programs institutionalized</li> <li>• Increased national govt. grants</li> </ul>
<b>Papua New Guinea</b>	<ul style="list-style-type: none"> <li>• Identify pathway to accelerate access (rural water sector in early stage)</li> </ul>	<ul style="list-style-type: none"> <li>• Greater intra-sectoral collaboration and govt. commitment to rural water</li> </ul>
<b>Timor Leste</b>	<ul style="list-style-type: none"> <li>• Financing for rural water</li> <li>• No earmarked maintenance budget</li> <li>• Water security issues</li> <li>• Human capacities</li> </ul>	<ul style="list-style-type: none"> <li>• Understanding of importance of O&amp;M for sustainability</li> <li>• Post construction support by govt.</li> <li>• Use of ICT for monitoring</li> </ul>
<b>Vietnam</b>	<ul style="list-style-type: none"> <li>• Water resources sustainability</li> <li>• Financial sustainability</li> </ul>	<ul style="list-style-type: none"> <li>• Focus on piped water systems</li> </ul>

**The Demand Responsive Approach remains the default, although the level of institutional embedding with local government varies**

The Demand Responsive Approach (DRA) is widely practised in Asian countries and is considered the default by most countries. However, the quality of implementation and service delivery depends on the local government's capacity for effective social mobilization, the professional capacity of community

## SUSTAINABLE SERVICES

### Rural Water Supply Sustainability

service providers, and the extent to which support, both technical and financial, is institutionalized in a decentralized responsibility for rural water supply service delivery at the service authority level. The Indian experience over the last decades shows that even in low-income states with more financial challenges are following a demand responsive approach, using different community-based management models, embedded in a decentralized service delivery approach. The development of clear roles and responsibilities of different government institutions at different administrative levels has supported a high level of sustainability of water service provision. A recent World Bank impact evaluation (Andres. L. et al., forthcoming) calculates that a demand responsive approach, if embedded within decentralized government support, on average performs 25 percent better than top-down implementation approaches on a composite sustainability index.

This index included aspects such as:

- i) availability and reliability of service,
- ii) household cost of service,
- iii) household satisfaction,
- iv) operation and maintenance (including downtime),
- v) O&M cost recovery levels, and
- vi) institutional sustainability and gender empowerment.

India has smaller and larger multi-village systems and a key lesson from this is to tailor the management models for specific situations, even including rather complex arrangements with bulk-water supply management organizations, combined with village-level distribution services. While management models can vary widely, states that have successfully scaled up sustainable piped services have all put in place strong local governance and support arrangements to the service providers.

- ***Decentralized service delivery and community management*** requires continuous support to district and village level institutions through government back-up support to districts and villages and professional technical and non-technical support to service providers
- ***Ensure sustainable funding for ongoing capacity building and training programs:*** Up to 40% of state rural water program budgets is allocated to capacity development, so that such programs can be periodically provided at state, district, village levels
- ***Maintaining community financing for Operation & Maintenance (O&M)*** is critical, and has been achieved in some systems through targeting 100 percent metered house connections and professionalizing service providers
- ***Rural water supplies cannot be considered in isolation from other water users,*** and service providers because of the links to overall water security (both quantity and quality)
- ***Public-Private Partnership (PPP) models*** can lead to accountable and more efficient services – although more testing and rigorous evaluation is needed for the different models
- ***Vested interests / the political economy*** need to be addressed to scale up programs: putting in place management information systems, including procurement management and grievance redressal systems are important steps to improve accountability
- ***Community solid and liquid waste management is critical to include when moving to higher level services,*** especially in the context of densely populated neighborhoods.

Detailed lessons are documented in World Bank (2012). Review of World Bank Support to the Rural Water Supply and Sanitation Sector in India (1991 - 2011)

### Box 1: Key lessons and recommendations based on lessons from India

Professionalisation of service providers and post-construction support services are key to sustainability

## SUSTAINABLE SERVICES

### Rural Water Supply Sustainability

Post-construction support for rural water service providers can take different forms and requires varying levels of government intervention or oversight, depending on the prevailing management model. The participants broke into groups based on five models:

1. Community based organizations (CBO) – managing piped systems
2. Community based organizations (CBO) – managing non-piped systems (point source)
3. Self-supply (individual and small groups)
4. Privately managed water services
5. Regional public utilities taking on rural water provision

The group discussions led to a number of a key issues and shared perceptions, highlighted in Box 2:

#### Box 2 : Key issues on post-construction services

- Whatever management model is prevailing, post-construction support services are required in all cases to small-scale service providers, whether private or community-based.
- Most countries have no well-resourced national post-construction support system in place; especially CBOs for non-piped systems are “left to their own devices”
- CBO-managed piped systems mostly receive erratic support from local or provincial governments, depending on availability of staff and funds at different tiers of government; models with federated associations, like in Indonesia (and also in several countries in Latin America) are emerging, but sustainable financing and technical capacity remains a bottleneck
- Market-based approaches, accreditation of local consultants and delivery of capacity development services against a (partial) fee as tools to support professionalizing of services are emerging in the region, although cost recovery is not yet achieved for such programs and public funds are needed for further scale-up
- Only regional utilities/parastatal agencies will have the in-house financial and technical capacity to deal with all issues themselves, yet they also need access to professional development and new innovations
- Regional government/parastatal agencies are often expected to be providing post-construction support to smaller schemes in their territories, which has proved challenging due to limitations in resources and a tendency to focus on the larger schemes
- Regional utility and private sector models are in the highest need of regulation, especially around tariffs; oversight is equally important for CBO-based piped systems, although this is typically done at local government level
- Supported self-supply can be considered as a solution for very remote areas or in transitional situations when government investment cannot keep up with the need. Self-supply happens anyway, hence it is important that public resources are allocated to support functions. This can include regulation, quality standards and promotion of safe forms of self-supply
- Generally participants felt that post construction services should be paid out of public funds (domestic funds or external from development partners), and not through tariffs (contributions by service providers)
- However, in case of private sector models or more sophisticated small utilities/CBOs, contributions from service providers (raised through tariffs) could help to increase the financial sustainability of post construction services (and in some countries is practiced)

## SUSTAINABLE SERVICES

### Rural Water Supply Sustainability

- At least half of the participating countries have no nation-wide functioning and regularly updated rural water services monitoring systems in place (partial systems may be in place)
- Monitoring systems need to capture service delivery, not just presence of infrastructure, and – if possible - also include water quality parameters;
- It is of critical importance to develop monitoring systems as country-owned sector-wide initiatives to avoid the proliferation of project-based, or NGO-based reporting systems
- Service provider budget allocations need to be secured, as well as building local capacities for continued system maintenance
- Adaptation of ICT tools to local capacities and available financial resources is essential for sustaining systems
- Data usage is not happening automatically: focused efforts and assistance is needed to help stakeholders use data for policy decisions, planning and resource allocation
- Promising experiences in Asia can be found closing feedback loops through social accountability mechanisms in rural water (social audits, community scorecards, public hearing, grievance redressal/complaints monitoring); however, most experiences are small-scale and are not institutionalized

Some examples were discussed in more detail such as from The Philippines, Cambodia, and Indonesia, for which lessons have been documented by the World Bank (2015, 2016a, 2016b)

### **Sustainable financing is not yet a reality for most participating countries**

Funding and financing for rural water supply happens at different levels: scheme level, sub-national level and national sector level. Figure 1 illustrates the different elements of water service costs over the lifetime of a rural water service and the challenge of finding a sustainable funding arrangements for all cost elements from the three major sources of funds: tariffs (user contributions), taxes (domestic budget allocations at various levels) and transfers (external donor contribution in form of grants or credits to the sector). Participants agreed that many of them operate in an environment where important elements under-funded or not funded at all.

While funds are generally available (although not always sufficient) for initial capital expenditure, (through taxes/transfers and sometimes user contributions), and for operational O&M costs (through tariffs), other life cycle cost are not systematically budgetted for:

- i) major repairs/capital maintenance
- ii) direct support costs, such as for post-construction support, recurrent capacity building and other technical and commercial support services to water service providers, and
- iii) indirect support to service authorities and overall sector functions such as monitoring and asset management. The participants discussed various case studies that provide promising practices to move towards life-cycle costing, such as Pakistan's Punjab, where a sub-national maintenance fund has been developed to ensure major repairs are covered (World Bank, 2016c).

## SUSTAINABLE SERVICES

### Rural Water Supply Sustainability

#### Box 3 : Sustainable financing is not yet a reality in most participating countries

- Importance of moving to full life-cycle costing: With the conventional financing model, where taxes and transfers are used for initial Capital Expenditure (CAPEX) and tariffs tend to cover just operational O&M, other life cycle costs (e.g. major repairs, direct support) that are essential for sustainability are ignored
- Transition to increased revenues from tariffs is seen as an important way to improve the sustainability of financing streams for full life-cycle costing
- A move towards performance-based financing of service providers is preferred as a way to break the cycle of fixing and rehabilitating failing and badly managed schemes
- Bringing in repayable finance where possible will accelerate progress towards the SDGs for certain segments of the rural water sector; creating opportunities to insert commercial finance and private equity will be increasingly important; using public funds to leverage private financing will be the next frontier of financing; it will be important to work with banks on understanding the rural water sector.
- More innovation is needed, including testing of regional examples in financing for rural water supply; there are a number of interesting initiatives going on in the region, which could be shared more pro-actively (Pakistan, Indonesia, Philippines, Cambodia)

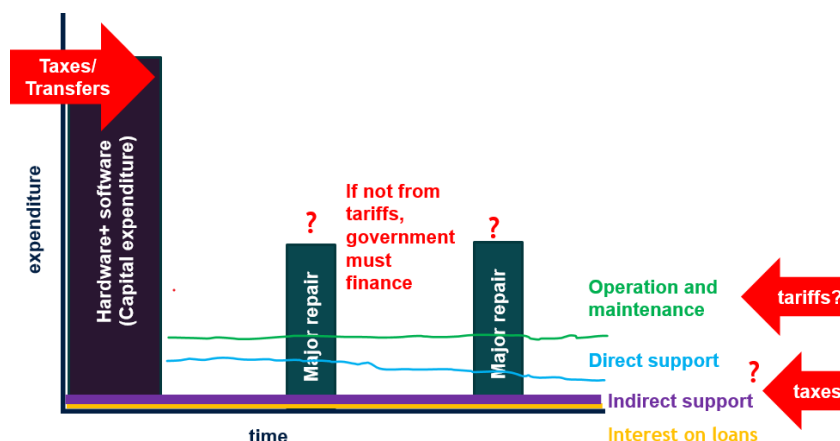

Figure 1: Generalised life cycle costs of rural water services and source funds

Conditions and development trajectories for moving rural water supply operators (small scale private sector and well-established CBOs) towards financially sustainable operations, and ultimately access repayable finance, such as loans from local banks. Given the unattractiveness of the rural market and the risks associated with such lending, access to finance often only can become a reality if some sort of concessional finance is offered and other credit enhancement instruments (like risk guarantees) are made available to banks, preferably combined with grants/incentives for water providers.

Experiences in Indonesia have shown that ability to access financing could be an incentive for rural water supply operators to further professionalize (World Bank, 2016b). Recent lessons from Cambodia illustrate that private operators can successfully access local commercial finance for expansion and even for new investment sites, when the overall regulatory and support environment is improved, technical assistance is provided, and banks are supported to better tailor loan products to the water supply business (World Bank, 2016a).

## SUSTAINABLE SERVICES

### Rural Water Supply Sustainability

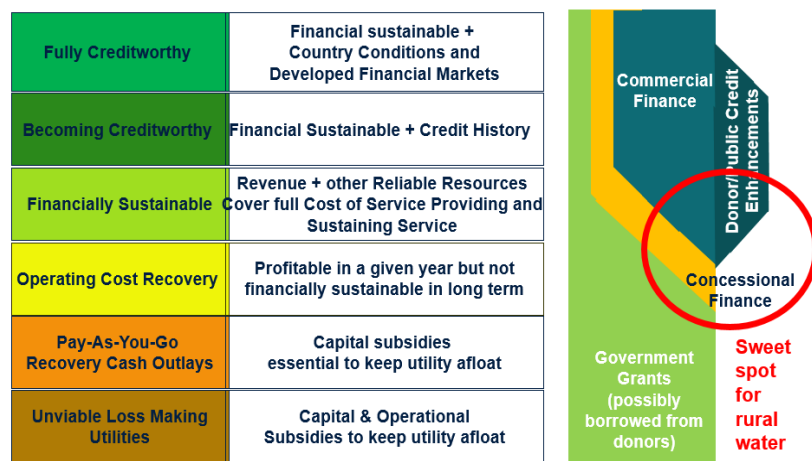

**Figure 2: Ladder to achieve sustainable financing for rural water**

At sector level, the World Bank has supported the government of the The Philippines in developing a proposed sector-level Unified Financing Framework. While not yet adopted by the government, this framework, through a proposed fund disbursement agency, helps to allocate targeted grants and mobilize loans and private equity to relevant water sector providers, including small-scale private players in the rural market, and local governments.

Box 3 provides an overview of the emerging issues and participants shared views around rural water financing.

### Tailored regulation and pro-poor policies are essential for realizing the equity mandate of the SDGs

Economic regulation, the setting of tariffs and fees for delivery of certain service levels, needs to balance and protect the interests of service providers, as well as viability of the service providers. The Philippines presents a good case of cutting-edge developments of regulating many, fragmented service providers, over 20,000 across the nation. The majority are small utilities, meaning less than 3,000 connections/households served, while 80 percent of the 4,700 piped water supply providers are still unregulated. Fragmentation not only exists on the service provider end, but also on the regulatory side, with multiple agencies involved, having distinct (and sometimes conflicting) mandates.

The Philippine’s National Water Resources Board (NWRB) is responsible for regulating private and community-based providers (associations), and has recently adopted a “light-handed” form of regulation. This means tailoring the approach and regulatory requirements to the type and capacities of small operators (and the risk of monopolistic behaviour, thus more attention is given to utilities posing greater risks of overcharging). Requirements are adjusted based on capacities of service providers to make it easier for them to comply with regulations (see also Fernandez-Millan, 2015).

A national survey was carried out to inform future policy on regulation, in order to bring more service providers under the regulatory regime, and provide assistance where needed most critically. NWRB’s role under the new regulation framework is to:

- i) categorize utilities,
- ii) rationalize the tariff setting, and
- iii) publish benchmarking results. The long-term perspective is to integrate all regulatory functions among various agencies under one economic regulator for the entire sector (see also <http://listahangtubig.cloudapp.net/>).

Experiences from Nepal and Kyrgyzstan with pro-poor measures and policies were presented and used as a basis for reflection by country teams. While Kyrgyzstan does not have pro-poor measures officially



## SUSTAINABLE SERVICES

### Rural Water Supply Sustainability

reflected in policy guidelines, a common practice is that national programs include post-construction campaigns to provide partial subsidies to connect vulnerable groups from municipal/district budgets, or arrangements for beneficiary household to participate as unskilled labour under community contracting arrangements, to account for the required household contribution. Nepal has a defined service standard that includes criteria on accessibility by all vulnerable groups as well as criteria for poor families. A new policy on accessibility has been introduced with “one household, one connection”, regardless of caste, income, or disability.

A number of common challenges as well as strategies and practices applied in various countries on regulation and pro-poor measures were identified (see Table 4).

**Table 4 : Challenges and best practices for regulation and pro-poor policy across Asia**

Challenges	Successful practices or strategies
<ul style="list-style-type: none"> <li>• Sector fragmentation and number of providers</li> <li>• Formalizing fragmented small service providers</li> <li>• Bringing small providers (CBOs) voluntary under regulation</li> <li>• Moving from standpipes to ensuring poor households have access to metered connections</li> <li>• Standards for service level and water quality regulation</li> <li>• Absence of regulator (self-regulation model) and lack of resources for regulation</li> <li>• Lack of information to determine tariffs</li> <li>• Absence of a national poor identification system</li> <li>• No tariff setting method and policy that fits rural water providers</li> <li>• Unstable rural incomes for regular tariff payments</li> </ul>	<ul style="list-style-type: none"> <li>• Create habit of tariff payment through pro-poor tariff structure for the poor</li> <li>• Facilitate self-identification of the poor with clear criteria to receive connection subsidies</li> <li>• Use of concessional finance and grants to reduce tariffs and connection fees</li> <li>• Legal framework and establish a regulatory entity that tailors to rural providers</li> <li>• Provide incentives for better performance</li> <li>• Use social protection targeting systems to reach poorest</li> <li>• Legal framework/act on regulation and service standards</li> <li>• Survey to register service providers/ CBOs</li> <li>• Couple regulation with capacity building program to improve compliance</li> <li>• Introduce complaint monitoring/customer feedback</li> </ul>

On water quality monitoring and regulation, the Thai government shared their recent developments. While Thailand successfully promoted rainwater and reached near universal improved access decades ago, the recent trend has been a switch to bottled water, provided through private companies, as a result of customer preferences. Bottled water is now the primary source of drinking water for almost 30 percent of Thailand’s population (bottled water also includes vending machines of purified water at reasonable cost).

Using the 2010 water quality legislation for tap water, the Ministry of Public Health runs a certification program for safe drinking water, in collaboration with metropolitan, provincial and local water utilities. Resulting from Thailand’s decentralization process, 58 percent of the people are served by local governments, 17 percent has no formal water supply i.e. uses self-supply, 16 percent are served by provincial water utilities, and 9 percent by metropolitan water utilities.

However, safe water certification in rural areas has been lagging behind and only 60 out of 5000 local government systems have been certified. Water safety plans are being implemented, under the leadership of local government. Water quality surveys for bottled water show that around a quarter of samples are sub-standard, and the Ministry of Public Health is expanding its surveillance program for water quality, implemented by provincial health staff (full lab analysis) and also by health volunteers who sample for residual chlorine and the absence/presence of coliform bacteria as an indicator of fecal contamination.

Outreach and capacity building programs for rural water scheme caretakers are also being rolled out in Thailand. Future efforts are directed to the expansion of the drinking water quality standards to include

## SUSTAINABLE SERVICES

### Rural Water Supply Sustainability

all water sources, not just tap water from piped networks. Also, the Ministry of Local Government, through its local authorities, is pro-actively addressing recent droughts through a so-called “Water Bank” policies, that develop larger storage reservoirs in rural areas where piped services are not available.

#### Box 4 : Tailored regulation and pro-poor policies are essential for the equity mandate of SDGs

#### Country-wide monitoring systems and social accountability mechanisms are in a work in progress

Through the use of various cases presented to the group, participants were able to understand the processes behind successful government-led monitoring initiatives and were exposed to successes and challenges of rural water monitoring across the region. Social accountability mechanisms that support two-way communication between customers and service providers to create more accountable rural services were introduced, using the accountability framework from the 2004 World Development Report (World Bank, 2003). Table 5 illustrates brief summaries of the case studies used.

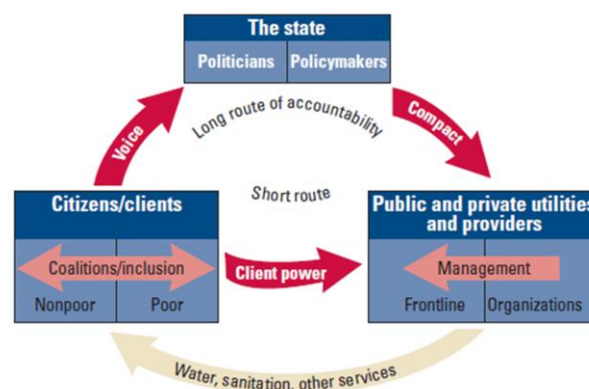

Figure 3: Accountability relationships for water service delivery

From World Bank (2003)

#### Table 5 Monitoring and social accountability case studies

##### **Nepal- use of social accountability tools**

Three selected social accountability tools for rural water supply services in Nepal were used for the whole project cycle, with a focus on institutionalizing social accountability mechanism in the post-construction stage.

##### *How do accountability mechanisms and feedback loops work?*

At the implementation (planning, design, construction) stage, feedback loops are used for addressing immediate issues so that projects can be implemented to a high quality and mitigate conflict or issues later on. Importantly, feedback loops help to prevent problems before they occur. At the operation/post construction phase, feedback loops can be differentiated into two levels. At the water supply scheme level, the findings from social accountability exercises can be used to help formulate improvement action plans for better provision of water supply service by a community-based operator. At the service authority (district) level, the results can be built into the district-wide functionality strategies and annual improvement plans. A significant challenge in feedback loop is how to make the recommendations, commitments, action plans binding for the respective stakeholders.

## SUSTAINABLE SERVICES

### Rural Water Supply Sustainability

#### *How to ensure usage of data?*

A big challenge is that a lot of data is generated but not always used. Some recommendations on how to stimulate data usage are:

- Staff of responsible authorities should be evaluated against outcomes of the use of social accountability tools e.g. not the activity to hold a social audit or public hearing but rather by what is done with the actions and commitments resulting from these exercises)
- District and village level WASH Coordination Committees can be strengthened to use monitoring/social accountability data for improving rural water supply services (as they already do so for sanitation)

#### *Challenges in social accountability*

Institutionalizing social accountability is a challenge because it requires good facilitation and a feedback loop to be effective. Thus this bears a cost, needs capacity building, and an institutional home. In Nepal, the recommendation has been to integrate social accountability as a function in the agency responsible for providing post construct support to the service providers (water user committees). The agency can conduct sample-based social accountability exercises in selected schemes each year through the Federation of Water Users Nepal (who are trained in the tools).

#### ***SIASAR – Monitoring Rural Water Supply and Sanitation in Latin America***

SIASAR is a rural water supply and sanitation monitoring system developed from 2011 onwards, which is now in use in 8 countries in Latin America.

(see [http://www.siasar.org/pdf/publicaciones/SIASAR\\_WBG\\_Water.pdf?nom=Reglamento&text=pdf](http://www.siasar.org/pdf/publicaciones/SIASAR_WBG_Water.pdf?nom=Reglamento&text=pdf)) also

A regional agreement coupled with the strong country ownership has fostered the support from donors and stakeholders. This is critical because each country is responsible for data collection and updating. Software is free and open source and is being translated into English this year for wider usage globally. This generated interest among many of the event participants and discussions about whether a similar system could have application in Asia, or parts of Asia.

#### ***India: Uttarakhand Management Information System (MIS)***

The Management Information System (MIS) in the state of Uttarakhand in India is used during all phases of project implementation and post-construction. Its use is an integrated activity within rural water service delivery programs (<http://swajal.edehradun.com>). The system captures quantitative information in a transparent manner and qualitative information is periodically evaluated by a third party. The system allows for a timely analysis and data aggregation to track progress, process quality and sustainability of services for different users, such as village committees, as well as district and state level. Impacts of the system have been:

- Reducing time and efforts for generating information required at various levels.
- Enhancing capacity of user community where community members are able to monitor the progress, quality and timely completion of the schemes.
- Improving the number of documents maintained at the community level
- Improving transparency and accountability
- Declining problems at community level due to available information, related to i) all aspects including design, implementation, O&M, procurement of local and non-local materials, and ii) tracking of works and installment of payments released to the local governments/communities
- Identifying and addressing lagging schemes for special capacity building programs / trainings

For the MIS to work sustainably and effectively, it has been critical that,

- i) the systems captures service delivery indicators,
- ii) is used sector-wide (not project-based),

## SUSTAINABLE SERVICES

### Rural Water Supply Sustainability

- iii) budgets have been allocated for its use,
- iv) in-house expertise of host and local support capacities are adequate,
- v) more than one/off capacity building is delivered,
- vi) performance-based incentives are linked to MIS reporting; and
- vii) regular independent reviews carried out.

### *Timor-Leste SMS-based Monitoring System*

SIBS is a Tetun acronym meaning Sistema Informasaun Bee no Sanementu (Information System for Water and Sanitation). Data is collected on 11 indicators by 88 government WASH facilitators on three monthly cycles.

The data is reported back to national level government from sub-districts level via mobile phone text message (SMS). Where WASH facilitators encounter problems with SMS or their phones are damaged or lost, the WASH facilitator can revert back to paper-based data collection. The data is used for planning and resource allocation at national level, and thus far only to a limited extent by district technical staff.

Challenges identified:

- Remote places are rarely visited due to challenging conditions such as poor roads
- Data collection is not incentivized in any way
- Limited training has been provided to WASH facilitators in use of the data
- There is no O&M response associated with the data collection; this is a disincentive for those collecting the data as they cannot offer anything to the community
- At district level staff have limited capacity to use computers to view and use the data

Going forward, more attention will be paid to i) the enforcement of the data collection processes, ii) training and capacity building of all levels of government in use of SIBS data to inform decisions, iii) incentives for WASH facilitators to collect data from challenging areas e.g. travelling allowances, iv) upgrading of phones.

The case studies and subsequent discussions clearly illustrated that country-wide comprehensive monitoring systems and the at-scale use of social accountability mechanisms requires much more attention across the pan-Asian region, building on good regional and global examples. The key findings, emerging lessons and recommendations are included in Box 5.

## SUSTAINABLE SERVICES

### Rural Water Supply Sustainability

#### Box 5: Country-wide monitoring systems and social accountability mechanisms are work in progress

- Regulatory mandates for rural service providers needs to be established if still absent (self-regulation), including the necessary legal framework
- In a situation with many fragmented service providers, a first step in regulation is to carry out a survey and register different types of service providers (where and who are they? What type of service do they provide?)
- Adopting regulations tailored to capacities of service providers is an efficient approach
- A complementary capacity-building program for service providers is essential to bring them under a formal regulatory umbrella
- Incentives for good performance will help stimulate regulatory compliance (service levels and water quality)
- Reaching poorer segments requires pro-poor payment structures, to stimulate a habit of regular payments (tariffs/fees)
- Rural water investment plans are to be developed so that concessional finance and grants can be targeted for lagging areas, to support connections for poor households, and reducing tariffs where needed
- Institutionalizing pro-poor measures in national guidelines is important, aligning with national poverty targeting systems, or with clear criteria for community self-identification (plus related training to do so)
- The expansion of water quality surveillance and certification programs to rural areas needs to be resourced, complemented with local voluntary cadres using simpler surveillance practices (for a few parameters); water quality standards may need differentiation/adaptation for rural contexts

#### Conclusions and recommendations

Many participating countries have seen significant positive developments in recent years, with the large majority having met their Millennium Development Goal for water supply. Among those are a higher priority for rural water supply translating into higher budget allocations, an emerging focus on piped services and household connections (though varying greatly across countries), and an increased understanding and focus on institutional aspects important for sustainability. However, common challenges to sustainable service provision remain, including inadequate financing, low recovery from tariffs, and neglecting direct support and major repair costs. Limited human resources and recurrent capacity development needs, combined with poor asset management and the absence of technical support systems are also undermining sustainability. Finally, the rising challenge of water scarcity and drought is putting increasing pressure on freshwater supplies in the region.

The learning event generated a rich set of lessons about the status of rural water services across the greater Asian region, summarized as follows:

- For rural services to be sustained, the complementary roles of actors at different levels need to be strengthened: service providers, service authorities (local / sub-national governments) as well as national institutions
- While different management models for service provision will co-exist, key functions for service delivery need to be put in place: i) institutionalized capacities, ii) sustainable financing, iii) monitoring and regulation, iv) asset management, and v) water resource management
- Professionalizing service providers and continuous post-construction services are key to sustainability

## SUSTAINABLE SERVICES

### Rural Water Supply Sustainability

- Sustainable financing is far from a reality in most participating countries, and capital maintenance and direct and indirect support remain largely underfunded
- Tailored regulation and pro-poor policies for rural water are essential for the equity mandate of the SDGs and to elevate service levels
- Comprehensive country-wide monitoring systems and at-scale social accountability mechanisms are work in progress

The event was judged to be successful by the participants and the foundation has been laid for further networking and sharing across Asia, as well as exchanges with other continents. Follow-up activities, such as webinars through RWSN, country-exchanges, and in-country technical assistance, will be designed to respond to priorities identified by government representatives, namely: i) decentralization of rural water supply, ii) professionalization of CBOs and technical support systems, iii) monitoring systems, including water quality surveillance, iv) public private partnership models for rural water services, v) tariff setting practices and policies to achieve higher levels of cost recovery, and vi) solutions to adapt to climate change.

The learning event has helped to share innovations and experiences to facilitate joint critical reflection and create new insights for governments to bring different parts of the puzzle together to support sustainable water service delivery. While awareness on the bottlenecks is high and opportunities for mutual learning abound, more emphasis on practical learning is required going forward. Similar to how development partners and iNGOs have successfully facilitated learning on rural sanitation over the past seven years in Asia, regional learning on rural water supply could enhance country activities and help them make faster progress towards sustainable service delivery models for their contexts.

#### Acknowledgements

*This event was financed and led by The World Bank in collaboration with SNV, WaterAid Australia, RWSN, and all the participating governments. The final event report and presentations are available for download at: <http://www.rural-water-supply.net/en/resources/details/758>*

#### References

- Andres L. et. al (forthcoming) Sustainability of Demand Responsive Approaches to Rural Water Supply: The Case of Kerala
- IRC (2014) Water Services that Last (website: <http://www.waterservicesthatlast.org/> accessed 17.06.2016)
- Castro. A. et al (2015) Sustainable Capacity Building for Small Water Utilities. Improving Small Water Utilities and Financing Technical Assistance: Lessons from the Philippines. World Bank
- Government of India (2012) Review of World Bank Support to the Rural Water Supply and Sanitation Sector in India (1991 - 2011)
- World Bank (2003) World Development Report 2004 : Making Services Work for Poor People. World Bank. © World Bank. <https://openknowledge.worldbank.org/handle/10986/5986> License: CC BY 3.0 IGO.
- Fernandez-Millan (2015) Proposed Economic Regulatory Framework for the National Water Resources Board.
- World Bank (2012) Review of World Bank Support to the Rural Water Supply and Sanitation Sector in India (1991 - 2011). Government of India, Ministry of Drinking Water and Sanitation. World Bank
- World Bank (2015) Sustainable Capacity Building for Small Water Utilities. Improving Small Water Utilities and Financing Technical Assistance: Lessons from the Philippines. Washington
- World Bank (2016a) Strengthening Sustainable Water Supply Services through Domestic Private Sector Providers in Cambodia. Washington
- World Bank (2016b) Domestic Private Sector Participation in Rural Water Supply Services in Indonesia. Washington.

## SUSTAINABLE SERVICES

### Rural Water Supply Sustainability

UNICEF-WHO (2015) Joint Monitoring Programme for Water Supply and Sanitation  
(<http://www.wssinfo.org/> accessed 17.06.2016)

United Nations (2015) GOAL 6 Ensure availability and sustainable management of water and sanitation  
for all (website: <https://sustainabledevelopment.un.org/sdg6>, accessed 17.06.2016)

#### **Futher resources on rural water supply in Asia:**

<http://wsp.org/>

<http://rural-water-supply.net/en/region-and-countries/south-eastern-asia>

<http://rural-water-supply.net/en/region-and-countries/southern-asia>

## SUSTAINABLE SERVICES

### Rural Water Supply Sustainability

---

# Measuring the impact of multiple-use water services in Tanzania and Burkina Faso: water service quality, nutrition, and health

---

Type: Short Paper

**Authors:** Sara Marks<sup>1\*</sup>, Ariane Schertenleib<sup>1</sup>, Honoré Biauou<sup>2</sup>, Kees Vogt<sup>2</sup>, Boukari Salifou<sup>2</sup>, Muganyizi Ndyamukama<sup>2</sup>, Ilyasse Kabore<sup>2</sup>, Emily van Houweling<sup>3</sup>, Vincent G. Vyamana<sup>4</sup>, Vivienne Abbott<sup>5</sup>, Mary Renwick<sup>5</sup>

<sup>1</sup>Eawag/Sandec, Switzerland

<sup>2</sup>Winrock International, USA

<sup>3</sup>Virginia Tech, USA

<sup>4</sup>WASH/GLOWS Tanzania, USA

<sup>5</sup>Consultant, USA

\*Senior Scientist, Eawag / Sandec, Switzerland, [sara.marks@eawag.ch](mailto:sara.marks@eawag.ch), +41 58 765 5631

### Abstract/Summary

Multiple-use water services (MUS) is an integrated service delivery approach that takes into account households' full range of water needs. Past studies have shown the benefits of MUS in terms of enhancing income and livelihoods diversification. However, little is known about whether MUS is associated with improved health, nutrition, or water service quality. We used a matched control design dietary diversity among rural households receiving MUS through two large-scale water supply programs in Burkina Faso and Tanzania. Data was collected from 2,704 households representing five MUS typologies and a control group. Key informant interviews, focus group discussions, and water quality testing were also conducted. Comparisons across different MUS household typologies and the control group reveal a consistent positive trend regarding the benefits of MUS one to four years after project implementation. Households receiving MUS have experienced fewer injuries, enhanced food security, and use more reliable and safe water sources. These results contribute to a growing global evidence base regarding the variety of benefits associated with higher levels of water services in rural communities.

### Introduction

Multiple-use water services (MUS) is an integrated water service delivery approach that takes into account a range of household' needs when planning, financing and managing water services. The MUS model explicitly acknowledges households' tendency to re-allocate water intended for one type of activity to another, such as domestic water supplies being used for livestock watering or irrigation channels being accessed for drinking needs. In this way, MUS recognizes a more holistic approach that protects water systems from overuse, while simultaneously supporting synergistic uses of water at the household- and community-level. In practice, MUS typically delivers a higher level of water service, with at least 50 liter per capita per day (LPCD) available on household premises.

Past studies have shown the benefits of MUS in terms of enhancing water-based income generation (Crow, Swallow, & Asamba, 2011; Noel, Hoang, Soussan, & Lovett, 2010), especially in the presence of enabling factors, such as markets and electricity (Davis, Hope, & Marks, 2011). In rural Senegal, productive uses of water were linked to livelihood diversification among women (van Houweling, Hall,



## SUSTAINABLE SERVICES

### Rural Water Supply Sustainability

Diop, & Davis, 2012) and improved technical operation of water systems (Hall, Vance, & van Houweling, 2014).

Other potential benefits of MUS beyond income and livelihoods are less understood. Fully documenting such benefits is necessary to justify the often higher upfront investment required to establish the higher level of service offered by MUS.

### Context, aims and activities undertaken

*Study Objective:* The study’s objective was to rigorously assess a range of impacts expected to arise from MUS, including improvements in child health, safety during water collection, food security and nutritional status [2]. Sandec’s Water Supply and Treatment group collaborated with United States Agency for International Development (USAID) and the Global Water for Sustainability (GLOWS) program, including partner organizations Winrock International, Virginia Tech, and Florida International University, to systematically evaluate the MUS component of two rural water supply programs in Africa.

*Background:* The first program, called the West Africa Water, Sanitation and Hygiene (WA-WASH) program in Burkina Faso (2011 to 2015), offered households the option to invest in subsidized self-supply (upgraded private wells equipped with rope pumps), along with other program activities. The second program, called the Integrated Water, Sanitation and Hygiene (iWASH) in Tanzania (2010 – 2015), used a demand-led approach to engage community members during the installation of new or upgraded communal water supply systems (reticulated networks, upgraded community wells with rope pumps, and/or livestock troughs). Both programs featured “impact boosting activities” that were tailored to local conditions and designed to maximize the systems’ potential for productive use. These activities included seed distribution networks, market garden demonstrations, support for improved poultry housing (kinengunengu) and livestock husbandry (Figure 1).



## SUSTAINABLE SERVICES

### Rural Water Supply Sustainability

**Figure 1. Impact boosting activities within the WA-WASH and iWASH programs**

*Study Design.* Baseline (pre-intervention) data on outcomes of interest for this study were not collected prior to the launch of the programs. Thus, it was not possible to directly measure the before-after status of households receiving MUS. We instead relies on a two-step strategy to estimate impacts: (1) randomized sampling of various household typologies in WA-WASH and iWASH intervention communities, as well as a control group, and (2) statistical matching techniques. This article reports results for the first step only.

Communities that had participated in the iWASH and WA-WASH programs at least one year prior to the study were eligible for enrolment into the *treatment group*. Communities that were located within the program service regions and were pre-qualified for participation (but had not yet done so) were eligible for enrolment in the *control group*. From this eligible pool, communities were purposively selected to optimise variation in the water supply and impact boosting intervention(s) received.

Based on community visits and discussions held with field staff, the study team pre-defined and randomly sampled several household typologies. Within WA-WASH communities, household typologies include: (a) investors, (b) neighbours of investors (those who did not invest but who are accessing an investor’s upgraded well), and (c) non-neighbours (those who did not invest in and do not use an investor’s upgraded well, i.e., a pseudo-control within treatment communities). Within iWASH communities, household typologies include: (d) members of MUS interest groups and (e) non-members of a MUS interest group. Finally, households randomly selected from control communities (as described above) were defined as: (f) control households.

*Data Collection.* Between May and October 2015, field teams conducted 2,704 interviews with heads of households (men and women). Surveys probed on the water sources used throughout the year for any purpose, health status of adults and children, self-reported food security, dietary diversity, and other measures of well-being. In addition, semi-structured interviews were held with a key informant in each community (typically the village chief) to estimate population size, proximity to markets, and other community-level measures. Focus group discussions were held with men and women (both separately and mixed) of all household typologies in Burkina Faso to better understand the changes experienced since community members had participated in the WA-WASH program. Finally, fecal contamination of households’ main drinking water sources was assessed using compartment bag test (CBT) kits in Burkina Faso (n = 181) and hydrogen sulfide (H<sub>2</sub>S) vials in Tanzania (n = 35). Table 1 summarizes household typologies and sample sizes.

Category	Household typology	Household interviews	Focus group discussions	Key informant interviews	Microbial water quality
<b>WA-WASH (19 communities)</b>	a. MUS investors	146	8	19	59
	b. Neighbours	292			0

## SUSTAINABLE SERVICES

### Rural Water Supply Sustainability

Category	Household typology	Household interviews	Focus group discussions	Key informant interviews	Microbial water quality
	c. Non-neighbours	451			59
<b>Control – Burkina Faso (9 communities)</b>	f. Control	438	0	9	63
<b>iWASH (7 communities)</b>	d. MUS interest group members	322	0	7	35
	e. Non-members	410	0		
<b>Control - Tanzania (3 communities)</b>	f. Control	645	0	3	0
<b>Total sample size</b>		2,704	8	38	216

Table 1. Household typologies and sample sizes for the WA-WASH and iWASH programs

### Main results and lessons learnt

*Illness and Injuries.* As compared to control households, MUS households reported experiencing fewer instances of children experiencing diarrheal episodes in the past week, as well as fewer injuries experienced by women while fetching water. In bivariate tests, only the difference in the rate of injuries among households in the iWASH program (3%) and control communities (12%) was statistically significant ( $p < 0.05$ ). Other health measures were not found to be significantly different across MUS and control groups.

*Food Security.* The survey asked respondents to rate their household's food security in the past year as being very secure, somewhat secure, or insecure. Interviewers explained the concept of food security in the local language. Results show that whereas food insecurity existed to some extent in all communities, the share of households identifying as insecure was significantly lower within communities receiving MUS. For example, within iWASH communities, 84% of MUS interest group members identified as “very secure”, as compared to 65% of non-members and 53% of control households reporting the same.

*Nutritional Status.* The household survey included a standardized set of questions designed to assess the overall nutritional status of women of reproductive age (FAO 2014). Three measures were analysed: (1) the total number of food types consumed in the past week, (2) consumption of animal products (meat, milk and eggs), and (3) consumption of leafy green vegetables. Statistical comparisons revealed that overall dietary diversity was slightly but significantly improved only among households participating in the iWASH program (6.4 food types), as compared to control households (5.4 food types). In both programs, households receiving MUS were more likely to have consumed animal products in the past week, as compared to control households. For example, 92% of WA-WASH investors and 91% of iWASH

## SUSTAINABLE SERVICES

### Rural Water Supply Sustainability

interest group members had consumed meat, milk or eggs in the past week, as compared to only 82% and 77% of control households, respectively (Figure 2).

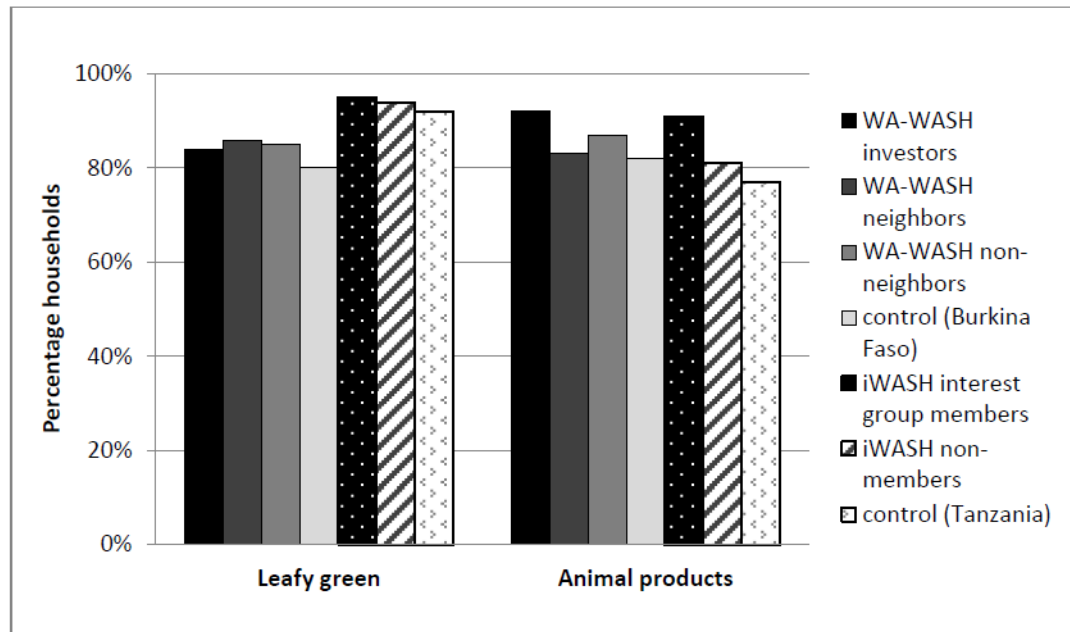

**Figure 2. Share of households consuming leafy green vegetables and animal products within the past week.**

*Water Service Quality:* We report preliminary results here for the WA-WASH program only. A greater share of MUS households (34%) reported waiting at some point during the year for their main drinking water source (traditional or improved wells) to recharge, as compared to control households (19%). However, MUS households typically waited for the water to return in the well for half the amount time as compared to control households (median of 60 minutes and 120 minutes, respectively). In terms of technical breakdowns, MUS households experienced fewer (16%) full day interruptions in water service, as compared to non-MUS households (23%). Water quality testing revealed that the majority (69%) of upgraded wells with rope pumps provided water categorized by the WHO as low risk (< 10 CFU/ 100 ml). By contrast, nearly all traditional wells (93%) were categorized as very high risk. A higher share of improved community wells (84%) had no detectable E.coli as compared to improved wells on premises (54%). Overall, we find most (75%) MUS investors are accessing a source categorized as safe or probably safe, whereas only 47% are doing the same in the control group.

### Conclusions and Recommendations

Our analysis of the impact of two large-scale MUS programs in Africa is limited due to the lack of statistical controls for potential confounding factors. Nonetheless, through strategic enrolment and randomized sampling across various household typologies, direct comparisons reveal a consistent positive trend demonstrating the benefits of MUS one to four years after implementation of the WA-WASH and iWASH programs. Households receiving MUS had experienced fewer injuries while fetching water, were more food secure, and were more likely to be consuming animal products. MUS systems were more reliable overall and delivered higher quality water. However achieving WHO standards for microbial safety for all remained elusive. These results expand the growing evidence base regarding the benefits of

## SUSTAINABLE SERVICES

### Rural Water Supply Sustainability

higher levels of water services in rural communities globally. Planned future analyses include using multivariate modeling to further control for sources of bias, investigating potential spillover effects of MUS among neighbouring households, and estimating the return on investment for MUS projects.

### Acknowledgements

Data for this study were sourced from USAID and the GLOWS program, with funding support from Winrock International, Florida International University, and Eawag. Data are publicly available and subject to USAID regulations.

### References

- Crow, B., Swallow, B., & Asamba, I. (2011): Community organized household water increases not only rural incomes, but also men's work. *World Development*, 40(3), 528–541.
- Davis, J., Hope, R. A., & Marks, S. J. (2011): Assessing the link between productive use of domestic water, poverty reduction and sustainability: Kenya country report. Report to the World Bank Water and Sanitation Program. Stanford University, Oxford University.
- Hall, R. P., Vance, E. A., & van Houweling, E. (2014): The Productive Use of Rural Piped Water in Senegal. *Water Alternatives*, 7(3), 480–498.
- Noel, S., Hoang, T., Soussan, J., & Lovett, J. C. (2010). The impact of domestic water on household enterprises: evidence from Vietnam. *Water Policy*, 12(2), 237–247.
- van Houweling, E., Hall, R. P., Diop, A. S., & Davis, J. (2012): The Role of Productive Water Use in Women's Livelihoods: Evidence from Rural Senegal. *Water Alternatives*, 5(3), 658–677.

## SUSTAINABLE SERVICES

### Rural Water Supply Sustainability

# Assessment of Sustainability of Rural Water, Sanitation and Hygiene Interventions in Rwanda

Type: Long Paper

Authors: Murtaza Malik, Lambert Karangwa, Aime Muzola, James Sano, Jean Marie Vianney Rutaganda, and Gedeon Musabyimana

## Abstract/Summary

This paper describes the methodology used for, and findings of, the assessment of sustainability of rural water, sanitation and hygiene (WASH) interventions under Rwanda WASH Project implemented by the Government of Rwanda with support from the Government of the Netherlands and UNICEF during 2009-14. The methodology involved development of the assessment tools, household surveys, focus group discussions, interviews with key informants and audit of WASH infrastructure. The sustainability of the project was assessed against 22 indicators grouped under five categories i.e. institutional, social, financial, technical and sanitation and hygiene. The overall sustainability score for the project (four districts) averaged 86% in 2014, showing a significant increase when compared with the corresponding scores of 70% in 2011 and 75% in 2013. The experiences of Rwanda WASH project demonstrate that regular sustainability assessments, though requiring significant financial resources and efforts, contribute to a considerable improvement in the sustainability of WASH interventions.

## Introduction

The Government of Rwanda, with support from the Government of the Netherlands and UNICEF, implemented the Rwanda Water, Sanitation and Hygiene (WASH) Project during 2009-2014. The project sought to contribute to improved child survival through increased access to sustainable safe water and sanitation and improved hygiene practices in four priority districts namely Rubavu, Nyabihu, Musanze, and Burera located in the north-western part of Rwanda.

The key achievements of the project till December 2013<sup>63</sup> include provision of access to safe water supply to 500,000 beneficiaries through construction of 35 piped water supply systems (involving more than 600 kilo meters of pipeline) and drilling of 29 boreholes; provision of piped water supply to 108 schools and 23 health centres; provision of rain water harvesting facilities in 258 schools and 50 health centres; provision of sanitation facilities to 160 schools and 29 health centres; promotion of safe hygiene practices and household sanitation benefitting 450,000 people; and capacity building for sustainable operation and maintenance of the supported WASH systems.

The Rwanda WASH project, which had a total budget of approx. US\$ 24 million, was coordinated by Rwanda Water and Sanitation Corporation (WASAC), under the leadership of the Ministry of Infrastructure, Government of Rwanda. A key component of the project design was to ensure sustainability of the supported interventions after the external support had stopped. Consequently, an annual sustainability assessment was built into the project at the design stage. So far, three assessments have been conducted since the project inception i.e. during 2011, 2013 and 2014 to assess the sustainability of the completed interventions. Important insights generated from these assessments were used to further enhance the project sustainability.

This paper describes the methodology used for assessment of the sustainability of the Rwanda WASH project as well as its key findings. The experiences of the sustainability assessment exercise in Rwanda could be used for assessment of sustainability of rural WASH interventions elsewhere, especially where the rural water supply systems are being managed by the private water operators.

<sup>63</sup> The project formally concluded in December 2015 but almost all the planned project interventions were completed by end of 2013.

## SUSTAINABLE SERVICES

### Rural Water Supply Sustainability

#### Description of the Methodology

The sustainability of rural WASH interventions remains a major challenge in the developing countries. In Rwanda, where the coverage of improved water supply and sanitation is 85% and 83% (GoR, 2016), respectively and open defecation is estimated at 2% (UNICEF and WHO, 2015), sustainability is emerging as a key sector challenge with over 30% of the rural water supply systems being non-functional (WASAC, 2016). Increased emphasis is, therefore, being placed on assessing the sustainability of WASH interventions, particularly for donor-fund projects. Consequently, a number of tools have been developed for this purpose (Boulenouar, Schweitzer and Lockwood, 2013; Ockelford and Cohen, 2013; Adank and Kumasi, 201; Godfrey et al., 2014).

The methodology used for assessment of the sustainability of interventions implemented under Rwanda WASH project was based on the experiences of previous sustainability assessments carried out for Rwanda WASH project (GoR and UNICEF, 2011 and 2013) as well as other countries (Godfrey et al., 2014) with adjustments made to suit the local context i.e. with focus on private operators, who were engaged to operate and maintain the water supply systems constructed or rehabilitated under the project by the Districts.

The assessment was carried out with the following objectives (i) to assess the sustainability of the water and sanitation facilities constructed, and sanitation and hygiene promotion related intervention implemented, under the project in four target districts and (ii) to recommend necessary actions to improve sustainability outcomes.

The methodology for the assessment, which was led by the Ministry of Infrastructure, Government of Rwanda, and conducted during November-December 2014 by an independent audit company engaged through competitive bidding process as per terms of reference agreed with the Government, included review of relevant project documents, development of tools (scoring matrix, survey questionnaires, focus group discussion and in-depth-Interview guides), primary data collection using qualitative and quantitative methods, and data analysis. The data collection exercise used for the assessment is briefly described as follows:

- (i) Household survey: Household interviews (1000 households, average 250 per district selected randomly) were conducted to get the views of the community members on behavior change communication interventions; hygiene practices; sources of water and the cost of water. At each household, a face to face interview was conducted as well as a structured observation of aspects such as the general hygiene conditions of the home e.g. cleanliness, waste disposal, availability of a latrine, condition of the latrine; construction quality, status i.e. full or still in use, structure of the walls, roofing and doors, latrine cover, availability of hand washing facility and water and soap near the latrine, cleanliness of the latrine and presence of faeces around the latrine and around the home. In addition to the above, the enumerators looked out for incidences of open defecation around the community as they visited the selected households;
- (ii) Interviews with key informants: A total of 89 key informant interviews were conducted. The key informants were selected based on their roles in relation to water and sanitation and included government ministries, NGOs, private water operators, school head teachers and health center officials;
- (iii) Focus group discussions: A total of 35 focus group discussions were conducted with community members and water point committees; and
- (iv) Facility audit: A facility audit was carried out using an observation check list for the facilities supported under the project in the four districts. In this regard, all the 35 water supply systems constructed under the project in the target districts were assessed (94% of which were constructed before end of 2013). As regards boreholes, 14 out of 29 boreholes, almost half of the total boreholes constructed were surveyed. Similarly, infrastructure supported in 17 health centers and 52 schools was assessed.

The enumerators recruited for the assessment had strong experience in conducting similar studies with a considerable number having been on the team for the previous sustainability assessments. A three-day

## SUSTAINABLE SERVICES

### Rural Water Supply Sustainability

training was, however, conducted for enumerators, which involved one day of field work (i.e. pilot testing and reviewing of the tools).

The household survey questionnaire was scripted onto a mobile device with inbuilt skip routines to minimize errors. Completed questionnaires were directly uploaded onto the server, downloaded and reviewed by the data team before the data was exported to SPSS Statistical Software.

All the data collected was analyzed using SPSS statistical software while findings from the focus group discussions and facility audits were summarized into grids.

The indicators used and the corresponding weightage used for assessment of the sustainability are presented in Table 1.

**Table - 1: Matrix used for calculation of sustainability scores**

Categories and Indicators	Maximum Score
<b>1. Institutional Aspects*</b>	
1.1 Enabling environment- WASH systems, institutions, policies and procedures at the national, district and community level are functional and meet the demand of users	5
1.2 Clarity of roles and responsibilities - WASH service users, authorities and service providers at the local, district and the national level are clear on their roles and responsibilities and are capable of fulfilling these roles effectively	5
1.3 Existence of updated database for water supply systems	5
Total	15
<b>2. Social Aspects</b>	
2.1 Community knows where to go in case of breakdown of water supply system	4
2.2 Representation of women in water point committees	4
2.3 Social marketing - training and information on WASH and behavior change received at household level	4
2.4 Social inclusion - all community members (including women, widows, poor and people with disabilities) are involved in WASH activities	4
2.5 Community perceptions towards the water supply systems (accessibility, acceptability, affordability, quantity and quality)	4
Total	20
<b>3. Financial Aspects – water supply</b>	
3.1 System to collect and manage funds is functional	5
3.2 Quality of financial records	5
3.3 Income is equal to or higher than the expenses	5
3.4 Financial capacity of the District for major repairs	5
Total	20
<b>4. Technical Aspects – water supply</b>	
4.1 Construction quality	5
4.2 Functionality	5
4.3 Maintenance	5
4.4 Availability and accessibility of spare parts	5
4.5 Frequency of break downs	5
4.6 Capacity of the Private Water Operators for routine repairs	5



## SUSTAINABLE SERVICES

### Rural Water Supply Sustainability

Categories and Indicators	Maximum Score
4.7 Time spent to repair	5
Total	35
<b>5. Sanitation and Hygiene</b>	
5.1 Functionality (quality and maintenance of latrine)	4
5.2 Status of Open Defecation	2
5.3 Hygiene	4
Total	10
<b>Overall Total Score</b>	<b>100</b>

The scores per district from the above analysis were then categorized as follows:

- Below 50% = Low sustainability level
- Between 51% - 75% = Average sustainability level
- Between 76% - 90% = Satisfactory sustainability level
- Above 90% = Good sustainability level

### Main results and lessons learnt

#### 1. Key Results

The overall sustainability score for the project (four districts) averaged 70% in 2011 and 75% in 2013 (GoR and UNICEF, 2015). This increased to 86% in 2014. As can be seen from Figure 1, there is also a considerable improvement in district scores over the years. Whereas in the previous assessments, Musanze and Nyabihu districts were the only districts found to be at satisfactory sustainability levels, now all four districts are almost at par regarding sustainability levels due mainly to hand-over of the management of water supply system to the private operators.

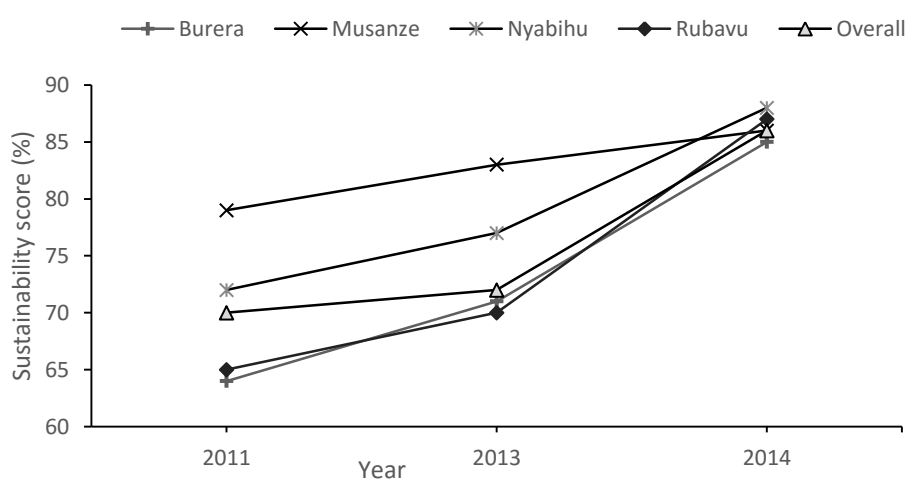

**Figure 1: Project sustainability trends during 2011 to 2014**

The scores achieved by the project in 2014 for various categories of sustainability aspects (Table 1) are briefly discussed as follows:

## SUSTAINABLE SERVICES

### Rural Water Supply Sustainability

1. The institutional sustainability of the project averaged 87%. The contributing factors to satisfactory score for institutional sustainability included sector reforms implemented by the Government of Rwanda which resulted in creation of rural water supply services division in WASAC in 2014, improved management after hand-over of the water supply systems to the private operators, increased focus on decentralized service delivery by the Government of Rwanda and existence of database for water supply systems. An area of concern noted with regard to the institutional sustainability was lack of effective system for monitoring the performance of the private water operators.
2. The social sustainability averaged 82%. The satisfactory sustainability score was attributed to high awareness of community regarding where to report breakage/non-functionality, high degree of community awareness of the diseases that can be prevented by washing hands with soap, positive perceptions of community members towards inclusion of women, widows, the elderly and the poor in the project activities and improved community perception with regard to public standpipes (quantity, quality and accessibility). The related indicators/sub-indicators which scored low included percentage of people who confirmed receiving messages or information about sanitation and hygiene (despite the intensive community awareness campaigns), use of soap for handwashing, affordability/cost of water, perception of the community towards boreholes and involvement of people with disabilities in the project activities.
3. The overall financial sustainability for the project was rated at 90% i.e. 10% higher than 2013 score and one percentage point shy of good sustainability. While all the districts recorded increase in financial sustainability, Rubavu recorded the highest increase from 80% in 2013 to 100% in 2014. The main factor leading to this increase was the management capability of the private water operators (PWOs) for each district, especially for Rubavu where most of the water supply systems are being managed by country's largest and most experienced PWO. Other contributing factors included effective system for collection and management of funds (i.e. water vendors who sell water), high cost recovery and financial capacity of districts to undertake major repairs. Some districts, however, recorded low scores with regard the quality of financial records available with the PWOs.
4. The overall technical sustainability for the water supply systems averaged 91%, the only indicator which was categorized as having “good sustainability level”. The high technical sustainability score for the project was attributed to good construction quality, high functionality of the systems, easy availability of spares, ability of private operators to undertake timely repairs and low frequency of breakdowns. Several issues related to technical sustainability, however, were identified. These included maintenance, and decline in usage, of boreholes compared to piped water supply systems as well as poor maintenance of rain water harvesting infrastructure in schools.
5. The overall sustainability score for sanitation and hygiene averaged 69%. Though it increased considerably from an average of 55% in 2013, it remained the lowest of all the sustainability aspects assessed despite the high latrine coverage (93%) in the target districts. The low score for sanitation and hygiene was attributed mainly to the challenges pertaining to the quality and cleanliness situation of latrines, availability of handwashing facilities in the vicinity of latrines and hygiene around water points. For sanitation in schools, the key issues identified included lack of availability of sufficient funds for operation and maintenance and lack of ramps with appropriate slopes for people with disabilities in several schools located in mountainous areas characterized by steep slopes.
6. As part of the sustainability assessment, water quality of sampled water supply systems was assessed, though it was not included in the scoring exercise. The key issues identified in this regard included bacterial contamination and low pH for a few water sources.
7. The key recommendations of the sustainability assessment included the following:
  - (i) Conduct behavioral change communication campaigns in the target districts with strong focus on hygiene and sanitation promotion.
  - (ii) Work with the private water operators and water point committees to devise and implement a mechanism for proper maintenance of the boreholes;
  - (iii) Allocate appropriate funds to address the issues related to maintenance of rain water harvesting system in schools as well as accessibility of sanitation facilities (i.e. construction of ramps with appropriate slopes);

## SUSTAINABLE SERVICES

### Rural Water Supply Sustainability

- (iv) Take appropriate actions for pH adjustment and chlorination of the concerned water supply systems; and
- (v) Devise an adequate reporting and monitoring system for the private water operators and arrange refresher trainings for them.

#### 2. Follow-up actions

Following the completion of the sustainability assessment, the key findings were shared with the concerned districts and the assessment report was finalized in light of their comments and feedback, where relevant and agreed and accepted by the independent audit firm. Subsequently, the Ministry of Infrastructure, Government of Rwanda, Water and Sanitation Corporation (WASAC) and UNICEF worked with the districts to prepare a management response which listed the key actions to be implemented in order to address the issues affecting sustainability as identified during the assessment. The agreed actions as per the management response are being followed through regular meetings with the district teams as well as field visits. Moreover, the findings of this assessment were used for evidence based advocacy which resulted in bringing the sustainability high on the sector agenda nationally and subsequent establishment of a task force on sustainability of rural water supplies under the Water and Sanitation Sector Working Group. Currently, the Government of Rwanda, with support from UNICEF and Japan International Cooperation Agency (JICA) and in collaboration with the districts and partners, is working on development of a national action plan for enhancing the sustainability of rural water supply systems. The Government of Rwanda's new water and sanitation sector policy, which is currently being finalized, also includes strong provisions with regard to sustainability as well as for addressing the issues identified during the sustainability assessment of WASH project.

It may be noted that the methodology for sustainability assessment described here has not yet been integrated into the current national monitoring framework due to the limitations of the existing sector management information system (MIS). The Government of Rwanda, with support from development partners, plans to develop and operationalize a new monitoring framework and MIS for WASH sector during 2017. The methodology used for the sustainability assessment and the related information gathered will inform the development of the new monitoring framework as well as the MIS.

#### 3. Lessons learned

The following key lessons were learned from the assessment of the sustainability of Rwanda WASH project:

1. For projects like Rwanda WASH project, the assessment of sustainability could cost up to US\$ 85,000 and take around four months to complete, including field work and drafting and finalization of the report. Given the fact that it is a time and resource intensive exercise, the assessment of sustainability needs to be planned carefully. Due consideration should be given to the timing i.e. rainy season, school holidays, community events, harvesting season and other factors that are critical for collection of adequate data or may contribute to delays.
2. The indicators/sub-indicators and the corresponding weightage used for assessment of the sustainability (Table 1) should be adjusted with due consideration to the changes in the context and approaches as the project interventions progress during the implementation period.
3. It is extremely important to select the right independent auditing firm having relevant experience and expertise, based on competitive bidding process and reference checks. For the projects of longer duration, the possibility of signing a long-term agreement with one firm should be considered to effect cost and time savings and to have quality output.
4. Considering the turn-over of the project staff, especially for the projects of longer durations, it is important to design a training module on assessment of sustainability for the staff.
5. For a sustainability assessment to be really meaningful, it is critical to put in place a follow-up mechanism to ensure proper implementation of the follow-up actions.

#### **Conclusions and Recommendations**

The sustainability of Rwanda WASH project was assessed using a tool adapted from the experiences of other countries with changes made to suit the local context. The assessment showed that the overall project sustainability was at satisfactory level (86%) in 2014. A comparison of the findings of this and the

## SUSTAINABLE SERVICES

### Rural Water Supply Sustainability

pervious project sustainability assessments showed a considerable improvement in the sustainability scores over the years following. Following completion of the assessment, the Government of Rwanda and WASAC, in collaboration with the respective districts and UNICEF, are taking appropriate measures to address the issues that may negatively impact the sustainability of project interventions.

As part of the sustainability assessment, no comparison was made between the project districts and non-project districts keeping in view time and resource constraints. Related assessments carried out by other partners, which did not capture the range of indicators assessed as part of the sustainability assessment, showed functionality of water supply systems was substantially higher in the project districts (where regular sustainability checks are conducted and follow-up actions taken) than the non-project districts. A study conducted in four districts of the Eastern Province of Rwanda, for instance, found that 87% of piped water supply systems were functional (JICA and WASAC, 2016). Compared to this, the functionality rate for the piped water supply systems for the project districts was 100%.

The experiences of Rwanda WASH project demonstrate that regular sustainability assessments contribute to considerable improvement in the sustainability of WASH interventions, through timely identification of sustainability bottlenecks and necessary follow-up actions for addressing the same. Moreover, the findings of the sustainability assessments could also be successfully used as an advocacy tool, as was the case in Rwanda, for prioritization of sustainability at the national level as well as by sector partners.

Given the resources and efforts required for carrying out the sustainability assessment, it is recommended to conduct these assessments once every two years rather than on annual basis. An alternative could be to design and carry out a simplified version of the sustainability assessment in between the comprehensive sustainability assessments. It is also recommended that the possibility of development of a simpler and cheaper sustainability assessment tool, which could be applied to large- and small-scale donor- as well as government-funded projects, should also be explored.

### Acknowledgements

The authors would like to express their gratitude to the Government of the Netherlands and UNICEF for supporting the Rwanda WASH project and to the Government of Rwanda for its leadership in the development and implementation of this project as well as in implementation of the recommendation of the sustainability assessments. Valuable contribution of the Ministry of Infrastructure; Ministry of Health; Districts of Burera, Musanze, Nyabihu and Rubavu; WASAC; NGOs and private sector partners is also acknowledged.

### References

- Adank, M. and Kumasi, T. (2013), ‘Sustainability index of WASH activities- Ghana Country Report’, Report prepared by Aguaconsult for USAID and Rotary International, Available at [http://www.washplus.org/sites/default/files/ghana\\_sustainability.pdf](http://www.washplus.org/sites/default/files/ghana_sustainability.pdf).
- Boulenouar, J., Schweitzer, R. and Lockwood, H. (2013), Mapping sustainability assessment tools to support sustainable water and sanitation service delivery, IRC, The Netherlands. Available at [http://www.ircwash.org/sites/default/files/2013\\_wp6\\_sustainabilityassessmenttools.pdf](http://www.ircwash.org/sites/default/files/2013_wp6_sustainabilityassessmenttools.pdf)
- Godfrey, S., van der Velden, M., Muianga, A., Xavier, A., Downs, K., Morgan, C. and Bartram, J (2014), ‘Sustainability check: five-year annual sustainability audits of the water supply and open defecation free status in the ‘One Million Initiative’, Mozambique’, *Journal of Water Sanitation and Hygiene for Development*, 4 (3), 471-483.
- GoR (2016), ‘Rwanda Integrated Household and Living Conditions Survey’ (EICV) 2013-2014-Thematic Report: Utilities and Amenities’, National Institute of Statistics, Government of Rwanda
- JICA and WASAC (2016), O&M Actual Condition Survey Report – water supply systems in Eastern Province, Vol 1, carried out by Kokusai Kogyo Co, Ltd. JICA and WASAC, Rwanda
- Ockelford, J. and Cohen, I (2013), ‘Sustainability check of WASH activities- Philippines Country Report’, Report prepared by Aguaconsult for USAID and Rotary International, Available at

## SUSTAINABLE SERVICES

### Rural Water Supply Sustainability

<http://www.aguaconsult.co.uk/assets/Uploads/Publications/PhilippinesSustCheckreport-FINAL-Jan-2013.pdf>.

GOR and UNICEF (2011), ‘Sustainability Check Report of WASH Project, UNICEF and Water and Sanitation Corporation’, Rwanda

GoR and UNICEF (2013), ‘Sustainability Check Report of WASH Project, UNICEF and Water and Sanitation Corporation’, Rwanda

GoR and UNICEF (2015), ‘Sustainability Check Report of WASH Project, UNICEF and Water and Sanitation Corporation’, Rwanda

UNICEF and WHO (2015, ‘Progress on drinking water and sanitation -2015 update’, WHO Switzerland. Available at [http://www.unicef.org/publications/files/Progress\\_on\\_Sanitation\\_and\\_Drinking\\_Water\\_2015\\_Update.pdf](http://www.unicef.org/publications/files/Progress_on_Sanitation_and_Drinking_Water_2015_Update.pdf)

WASAC (2016), ‘Minutes of the Stakeholders Workshop on Sustainable Operation and Maintenance of Rural Water Supply Systems’, held in Kigali on 16 March 2016, WASAC, Rwanda.

Disclaimer: The views expressed in this paper are solely of the authors and do not necessarily reflect the views of UNICEF and Government of Rwanda.

## SUSTAINABLE SERVICES

### Rural Water Supply Sustainability

---

# Elicitation of Determinants of Rural Households' Water Supply in Côte d'Ivoire: A Case Study

---

Type: Long Paper (up to 6,000 words)

**Authors** *Vassiki SANOGO; Senior Researcher, Florida State University-Center for Economic Forecasting and Analysis, USA, vassikisanogo@gmail.com, +1(850) 645-0190. Richard K. MOUSSA; Ph.D. Candidate, Université de Cergy-Pontoise, France.*

### Abstract/Summary

Problems of accessibility and quality of water are serious issues in rural areas in all developing countries. In Côte d'Ivoire, only 11.6% of household in rural areas have access to safe drinking water and only 26.8% of household in rural areas have a water source at home. However, annual water expenditure in rural areas are 28130 XOF (56.26 US \$) in average. In this paper, we conduct an economic evaluation of the water sector by pointing out the determinants of water source choice and water fees in rural areas in Côte d'Ivoire. By using the data from household living condition survey (2008), we estimated a multinomial logistic model and a Heckman selection model respectively to highlight determinants of households' water source choice and water expenditures. We find that education in household (reduces by 0.1382 the probability to choose ground of type 2), poverty status (reduces by 0.0273 the probability to choose safe drinking water), household and household's living house characteristics (household headed by women increases by 0.0468 it probability to choose safe drinking water) and time to water source are main determinants for choosing a water source (water source more than 15 minutes from house increases by 0.2215 the probability to choose ground water of type 1), while the water expenditures are determined by selected water source (the choice of ground water of type 1 instead of safe drinking water has no significant effect on annual water expenditures), household size (annual household water expenditures higher significantly with household size) and the distance to water source (Far the water source is, higher the annual water expenditures are).

### Introduction

Guaranteeing that rural residents around the world do not have to walk for hours to collect sufficient and safe drinking water is a huge challenge for developing countries. This case study raises insights for researchers, and all others stakeholders including decision makers, who are involved in trying to improve rural water supplies, in particular the limited successes and areas where approaches need to be radically improved. Considerable investments have been made in rural water supplies. The springtides have been protected; boreholes have been dug or drilled, and fitted with handpumps; piped water schemes have been constructed. However, the thoughtful issue is that progress is still much too slow, and rural water supply coverage significantly lags behind that of urban water supply. Further, many of the constructed services have not continued to work over the time. It has been estimated that only two out of three installed hand pumps are working at any given time. According to Davis J. et al (2008), many rural water supply interventions in developing countries have been marked by a poor record of sustainability. Indeed, thousands of people, who once benefited from a safe drinking water supply, now walk past broken handpumps or taps and on to their traditional, dirty water point. Despite best intents of sector professionals and practitioners that have contributed towards this problem, there are a number of unsolved issues of the rural water supplies sector.

This work aims to address the stress related to the access of affordable and reliable safe water at village, small town, local government or national scale in Côte d'Ivoire, by conducting an elicitation of the

## SUSTAINABLE SERVICES

### Rural Water Supply Sustainability

determinants of households' water supply choice and annual water expenditures. For this purpose, we should consider groups that are often marginalized such as the very poor, remote or pastoralist communities, as viewed by the 2009 report of the Water and Sanitation Program.

This study should help to understand the behavior of Ivorian's households related to rural water supply. Inherent in several papers in the literature on rural water supply services, it is assumed that “community management”, the independent of external supports of any kind, is sufficient to keep systems running once they are installed (Lockwood, 2003; Schouten and Moriarty, 2003).

However, this assertive of community management approach has been challenged in the recent studies. Schouten and Moriarty (2003), for instance, conducted a series of case studies of communities in which rural water supplies projects were well planned (i.e., based on users' caressed needs and preferences and with appropriate technologies). In the authors' findings, they stated that ongoing external support was still necessary to sustain project outcomes over time, even the substantial investment in building community capacity for system management. A review completed by Lockwood (2003) on dozens of rural water project assessments, and shown that in merely a minority of these projects were provisions for any sort of postconstruction support established as part of the planning process. Among projects with postconstruction support components, many were not evaluated in such a way as to be able to draw substantive conclusions. Furthermore, those which were thoroughly evaluated appeared to be unusual projects that included some levels of postconstruction support funded by external donors. Approaches such as Lockwood (2003) argues, would be unfeasible at scale or over time in the developing countries.

Further recent studies, as Prokopy and Thorsten (2006) examined the effects of postconstruction support on rural water system sustainability in 99 communities across two areas of Peru. The water systems investigated all provided household level services (i.e., piped water connections in the yard or patio). The authors did not detect any effect of postconstruction support on functioning of water systems, but did note that households in communities that received more postconstruction support visits were more likely to pay their water bills regularly and to express satisfaction with their water supply services, as compared to those in communities who received fewer visits. The authors did not test for effects of the different types of post-construction support that were provided to communities (e.g., engineering assessments, hygiene promotion, and financial assistance).

K. Komives et al. studied the impacts of postconstruction support for rural water supply systems in 200 villages located in two Ghanaian regions. The water systems included deep bore wells with handpumps. Many different postconstruction support programs were ongoing in the areas studied by the authors, which made isolation of effects for any particular type of support challenging. Generally, the authors concluded that the villages that received engineering oriented postconstruction support, training of the community members in maintenance and repair of the bore well, were more expected to have working water points as compared to those that did not receive such assistance. At the same time, the authors note that performance across the entire sample of communities was quite high, even in villages that did not receive postconstruction support.

With this study we contribute to first elisitate the determinant households' choise of water sources in Ivorian rural areas. In addition the study gave us significant insights of Ivorian houaseholds annual water expenditure.

Data were collected by the National Institut of Statistics, field data gathered using a household living condition survey that covered both rural and urban households in Côte d'Ivoire in 2008.

### Context, aims and activities undertaken

For our study, water sources have been classified in three (3) major sources: (i) safe drinking water that includes private and collective taps, and resellers of piped water, (ii) ground water of type 1 that includes hand pumps and public water fountain or pump, and (iii) ground water of type 2 that is an unimproved water source and that includes unprotected wells, lakes, streams, etc. In this paper, we aim to study the determinants of households' choice of primary source of water and the annual water expenditures accord- ing to household characteristics for households living in rural areas.

## SUSTAINABLE SERVICES

### Rural Water Supply Sustainability

Similarly to Fotue and Sikod (2012), we use a multinomial logistic model to describe major household characteristics that determine household choice of primary water source. We use this model because it better addresses qualitative dependent variable with more than two outcomes, and more specifically when these outcomes are not ordered. Let  $Y$  denotes a choice of water source.  $Y$  can take three possible modalities that are safe drinking water, ground water of type 1 and 2. Let  $X$  denotes a set of household characteristics such as household poverty status<sup>64</sup>, log of household total income, household size, number of household members that are literate, number of household members with college degree at least, household living house type, the number of rooms, the type of toilets, household region of residence, and the age and gender of household head.  $X$  also includes water sources characteristics such as time and distance to water source. Thus, the estimated multinomial logistic model has the following form:

$$P(Y_i = j) = \frac{\exp(X_i\beta_j)}{1 + \sum_{k=1}^2 \exp(X_i\beta_k)} \quad \text{with } j = 1 \text{ or } 2; \text{ and } P(Y_i = 3) = 1 - \sum_{k=1}^2 P(Y_i = k) \quad (1)$$

Where  $P(Y_i = j)$  denotes the probability that household  $i$  chooses the water source  $j$ . Parameters are estimated by maximum likelihood method. The estimated multinomial logistic model must meet the underlying hypothesis of independence of irrelevant alternatives (IIA). We test for that hypothesis by the use of Hausman’s IIA test.

The annual water expenditures can be null or unobserved for several households especially in rural areas. For that reason, we use a Heckman selection model to point out the determinants of the household annual water bills. This model is used because we face censored continue dependent variable. The Heckman selection model is based on the underlying assumption that there is non-random selection for observing the continue dependent variable. Let  $lwexp$  denotes the log of household annual water expenditures. Let  $D$  denotes the selection variable that is a binary variable that takes 1 if we observe water expenditures and 0 if not. Let  $X$  denotes household characteristics that are relevant for water consumption. These characteristics are household poverty status, log of household income, household size, household region of residence, and age of household head.  $X$  also includes water source characteristics such as type of water source and distance to water source. Let  $Z$  denotes household characteristics that impact selection for observable water expenditures. These characteristics are household poverty status, household size, household region of residence, and the type of water source chosen by the household. Thus the estimated Heckman selection model has the following form:

$$\begin{cases} \text{Regression model} & : \quad lwexp_i = X_i\beta + \varepsilon_i \text{ if } D_i = 1 \\ \text{Selection model} & : \quad \begin{cases} D_i^* = Z_i\delta + \mu_i \\ D_i = 1 \text{ if } D_i^* > 0 \end{cases} \end{cases} \quad (2)$$

Where the residual terms are  $\varepsilon_i \sim \mathcal{N}(0, \sigma)$ ,  $\mu_i \sim \mathcal{N}(0, 1)$ ,  $\text{Cov}(\varepsilon_i, \mu_i) = \rho$ . The inverse Mills ratio is given by  $\lambda = \rho\sigma$ .  $\rho$  must be significantly different from 0 to validate the underlying assumption of non-random sample selection. Parameters are estimated by maximum likelihood method.

### Main results and lessons learnt

The first part of this section establishes by giving some descriptive statistics, a state of accessibility and cost of water around rural areas in Côte d’Ivoire. Then we present and discuss results from our estimated models that assess determinants of safe drinking water accessibility and water bills.

### Descriptive statistics

<sup>64</sup> A household was supposed to be poor if the total expenditures per capita per day is under 661 XOF (1.322 US \$).



## SUSTAINABLE SERVICES

### Rural Water Supply Sustainability

The 2008's living conditions survey in Côte d'Ivoire is a national representative survey that covers 12600 households in both rural and urban areas; with 56.95% of household surveyed in rural areas. It provides information on household living condition, house characteristics, water supply and consumption. In this paper, we focus on rural areas. Thus all statistics below are produced on household living in rural areas. The statistics are also weighted to given a national representative assessment.

Figure 1 provides accessibility statistics for rural areas per region while Figure 2 provides statistics on annual water expenditures in rural areas per region.

As we can see in Figure 1, in 25% of rural areas in Côte d'Ivoire, no household has access to safe drinking water while in only 10% of rural areas, 38.2% of household have access to safe drinking water. Regions that are more concerned with low rates of household having access to safe drinking water are the North, especially the North West, the East and the West. The South and the Center of the country have higher rates of household that have access to safe drinking water. For the annual water expenditures, the higher fees are paid in the Center and the South of the country. In rural areas in Côte d'Ivoire, only 27.6% of household pay fees for accessing water. Those households pay on average 28 130 XOF per year and 50% of them have an annual bill under 18 250 XOF.

Table 1 below gives statistics on accessibility and fees with respect to the selected water source. Only 11.6% of household in rural areas use safe drinking water and 58.9% of them have the water source at home. For these households, the average annual income is 1 405 700 XOF (2811.4 US \$) and the average annual water expenditures is 29070 XOF (58.14 US \$). The water source most used in rural areas in Côte d'Ivoire (used by 48.8% of households) is the ground water of type 2 (that includes lakes, unprotected well, etc.).

In rural areas in Côte d'Ivoire, only 26.8% of households have a water source at home (against 46.6% in general in Côte d'Ivoire). 26.6% of these household use safe drinking water. These household are less poor than the others (42.3% of poor, average annual household income of 1 203 700 XOF, i.e 2407.4 US \$) and pay lower annual water fees (25200 XOF, i.e 50.4 US \$). Note that 71.1% of households living in rural areas have no water source at home. They must walk less than 5 kilometers to find water source and only 6% of these water sources are safe drinking water source. There are also 2% of households in rural areas that have to walk more than 5 kilometers to find water source and only 2.9% of these water sources are safe drinking water source.

### Household choice of water source

Household choice of water source has been modeled with a multinomial logistic model. The estimated model is globally significant with a pseudo R<sup>2</sup> equal to 22.6%. The water source taken as reference in the estimation is safe drinking water source. As expected, household, living house, and water source characteristics affect household choice of water source.

Poverty status and household annual income have the expected sign. Being poor increases the probability to choose ground water of type 1 and 2 instead of safe drinking water source (poverty reduces by 0.0273 the probability to choose safe drinking water). But there are weak evidences (significant at 10%) that the higher the household income is, the lower the probability to choose ground water of type 1 or 2 instead of safe drinking water (a unit additional income increases by 0.0049 the probability to choose safe drinking water). However, household size has no significant effect on water source selection.

Demographics characteristics play important roles. For instance the gender, as we could see in Table 3 below, the households headed by women are less likely to choose ground water of type 1 or 2 instead of safe drinking water (finding: household being headed by women increases their probability to choose the safe drinking water by 0.0468). This finding might be explained by two underlying phenomenon that are (i) households headed by women have significantly lower size (3.9 with standard deviation 2.7) than that headed by men (5.2 with standard deviation 3.5), that can be their expenditures, and (ii) households being headed by women might often be due to the fact that their husband are migrant that move to urban areas

## SUSTAINABLE SERVICES

### Rural Water Supply Sustainability

to work. We capture education effects with the number of household literate members and the number of household members with at least college degree. We find that the higher the number of household members with at least college degree, the lower the likely to choose ground water of type 1 or 2 instead of safe drinking water (a unit increase in the number of household members with at least college degree increases by 0.0568 the probability to choose safe drinking water and reduces by 0.1 the probability to choose ground water of type 2). The higher is the number of literate household members, the lower is the likely to choose ground water of type 2 instead of safe drinking water (finding: a unit increase in the number of literate household members the probability to choose safe drinking water increases by 0.0293, the probability to choose ground water of type 1 increases by 0.1088, and the probability to choose ground water of type 2 reduces by 0.1382). This finding highlights not only the important role of being literate on household’s choice, but also the important role of the school level. However the number of household literate number is not significantly discriminant for the choice of ground water of type 1 instead of safe drinking water.

Living house characteristics have also been analyzed. We find that living in high or middle standing houses instead of low standing house lowers the probability of choosing ground water of type 1 or 2 instead of safe drinking water (living in high standing house increases by 0.0801 the probability to choose safe drinking water and reduces by 0.1994 the probability to choose ground water of type 2; and living in middle standing house increases by 0.0319 the probability to choose safe drinking water and reduces by 0.0678 the probability to choose ground water of type 2). Comparatively to households living in house without toilets, households living in houses with toilets with or without flush are less likely to choose ground water of type 2 instead of safe drinking water (having toilets with flush increases by 0.2295 the probability to choose safe drinking water and reduces by 0.2598 the probability to choose ground water of type 2; and having toilets without flush increases by 0.0519 the probability to choose safe drinking water and reduces by 0.0584 the probability to choose ground water of type 2). However the type of toilets is not significantly discriminant for the choice of ground water of type 1 instead of drinking water. The number of rooms in the living house is not significant for the choice of water source.

The last set of variable to analyze is the characteristics of water sources. As we can see in Table 3 below, the higher the time to water source is, the higher the probability to choose ground water of type 1 or 2 instead of safe drinking water (having a time to water source less than 15 minutes increases by 0.3618 the probability to choose ground water of type 1 and reduces by 0.1108 the probability to choose safe drinking water; and having a time to water source high than 15 minutes reduces by 0.0706 the probability to choose safe drinking water). Households that have to go far to find water source are more likely to choose ground water of type 1 instead of safe drinking water than those with water source at home (having a water source at more than 5 kilometers of the living house reduces by 0.0507 the probability to choose safe drinking water and increases by 0.2215 the probability to choose ground water of type 1). These high variations in the probabilities highlight the important role of proximity to water source in the household’s choice of water source. More the water source is close to the living house, more the households are likely to choose a safe water source.

### Household annual water expenditures

The estimated Heckman selection model is globally significant. The residuals correlation term and the inverse Mills ratio are also significant. That validates our specification. The censored observations are around 72.4% of the overall rural sample.

In the selection model, all coefficients have the expected sign. Thus, using ground water of type 1 or 2 reduces the probability to have water bill. Poor households are less likely to pay water bill. Higher the household size is, higher is the probability to pay water bill.

From the water expenditures regression model, we find that selected water source affects the annual water expenditures. The choice of ground water of type 2 instead of safe drinking water reduces significantly the annual water expenditures. This finding holds because household that uses ground water of type 2 most often pays only few fees for treatment. However, the choice of ground water of type 1

## SUSTAINABLE SERVICES

### Rural Water Supply Sustainability

instead of safe drinking water has no significant effect on annual water expenditures. Far the water source is, higher the annual water expenditures are (having a water source at more than 5 kilometers far from the house increases the annual water expenditures). But there is no significant difference in water expenditures between household with water source at less than 5 kilometers and those with water source at home. This finding is justified by the fact that water source that are far from house involve direct cost such as transportation fees.

The study shows that the households annual water expenditures are significantly related with household size and are significantly less related with the poverty of households. That highlights the effect of household size on the water consumption. Household annual income level and household head characteristics do not significantly affect the water consumption.

Households living in the North, Center North, Center West, and Center East of the country have significantly lower annual water expenditures than those living in the district of Abidjan. This finding is the fact that in those areas except the district of Abidjan, households use paid water only to cook and drink; but for others uses (such as washing, cleaning...), they use free water sources.

### Conclusions and Recommendations

This study analyzed the determinants of household's choice of water source and the determinants of water bills in rural areas, in order to assess the need and pricing of rural water supply in Côte d'Ivoire. We estimate a multinomial logistic model and a Heckman selection model to reach this goal. We control for region disparities and we account for the main factor such as economic status, demographic characteristic, education, living house characteristics and water source characteristics that are determinants for the choice of water source and the annual water bills.

We find that education in household, especially the number of household members with at least college degree, is an important determinant of household's choice of water source. Poverty status, living house characteristics also play important role. Another important determinant for choosing a water source is the time to water source. Policy makers must conduct a policy of construction of water source closer to households in rural areas; that will allow household to choose a safe drinking water source. The households' water bills are determined by selected water source, household size and the distance to water source. Thus by reducing distance to water source, we can significantly reduce the water bills for household in rural areas.

### Acknowledgements

The authors would like to express their sincere thanks to the Florida State University Center for Economic Forecasting and Analysis (FSU CEFA), the Université Alassane Ouattara (Bouaké), the Université de Cergy-Pontoise (France), the ENSEA (Abidjan), and National Institute of Statistic of Côte d'Ivoire for their support on this project. The authors would also like to express their gratitude to the FSU-CEFA director Dr. Julie Harrington, and to the Dr. Vakaramoko Diaby for their guidance in the development of this project. Lastly, the corresponding author would like to thank his fellow colleagues for their interest and resolve to ensure the analysis results were made available for dissemination to a wider audience.

### Conflict of interest

The authors have no conflicts of interest to declare.

### References

Altaf, M. A., Whittington, D., Jamal, H., & Smith, V. K. (1993), Rethinking rural water supply policy in the Punjab, Pakistan, *Water Resources Research*, 29(7), 1943-1954.

## SUSTAINABLE SERVICES

### Rural Water Supply Sustainability

- Briscoe, J., de Castro, P. F., Griffin, C., North, J., & Olsen, O. (1990), Toward equitable and sustainable rural water supplies: a contingent valuation study in Brazil, *The World Bank Economic Review*, 4(2), 115-134.
- Davis J. et al., (2008), Sustaining the Benefits of Rural Water Supply Investments: Experience from Cochabamba and Chuquisaca, Bolivia, *Water Resources Research*, Vol. 44, W12427,
- Fotue L. and Sikod F. (2012), Determinants of the households' choice of drinking water source in Cameroon, *Journal of Sustainable Development in Africa*, vol 14, No 3, ISSN 1520-5509
- Giné, R., & Pérez-Foguet, A. (2008), Sustainability assessment of national rural water supply program in Tanzania, *Natural Resources Forum* (Vol. 32, No. 4, pp. 327-342). Blackwell Publishing Ltd.
- Gleitsmann, B. A., Kroma, M. M., & Steenhuis, T. (2007), Analysis of a rural water supply project in three communities in Mali: Participation and sustainability, *Natural Resources Forum* (Vol. 31, No. 2, pp. 142-150). Blackwell Publishing Ltd.
- Harvey, P., & Reed, B. (2004), Rural water supply in Africa: Building blocks for handpump sustainability, WEDC, Loughborough University.
- MacDonald, A., Davies, J., Calow, R., & Chilton, J. (2005), Developing groundwater: a guide for rural water supply, ITDG publishing.
- MacRae, D., & Whittington, D. (1988), Assessing preferences in cost-benefit analysis: Reflections on rural water supply evaluation in Haiti, *Journal of Policy Analysis and Management*, 7(2), 246-263.
- Sara, J., & Katz, T. (1997), Making the rural water supply sustainable: Report on the impact of project rules, UNDP-World Bank Water and Sanitation Program.
- Sutton S. (2009), An Introduction to Self Supply: Putting the User First Incremental improvements and private investment in rural water supply, RWSN (Field Note): [www.wsp.org](http://www.wsp.org)
- Schouten, T., and P. Moriarty (2003), Community Water, Community Management: From System to Service in Rural Areas, ITDG Bourton on Dunsmore, UK.
- Therkildsen, O. (1988), Watering White Elephants: Lessons From Donor-Funded Planning and Implementation of Rural Water Supplies in Tanzania, 224 pp., Scand. Inst. of Afr. Stud., Uppsala, Sweden.
- Whittington, D., J. Davis, and E. McClelland (1998), Implementing a demand-driven approach to community water supply planning: A case study of Lugazi, Uganda, *Water Int.*, 23, 134–145. (Reprinted in *Water Resources and Economic Development*, edited by R. M. Saleth, pp. 446–457, Edward Elgar, Cheltenham, U. K., 2002.)
- Whittington, D., Davis, J., Prokopy, L., Komives, K., Thorsten, R., Lukacs, H., & Wakeman, W. (2009), How well is the demand-driven, community management model for rural water supply systems doing? Evidence from Bolivia, Peru and Ghana, *Water Policy*, 11(6), 696-718.
- Whittington, D., Okorafor, A., Okore, A., & McPhail, A. (1990), Strategy for cost recovery in the rural water sector: a case study of Nsukka District, Anambra State, Nigeria. *Water Resources Research*, 26(9), 1899-1913.
- World Health Organization. (2012), Progress on Drinking-Water and Sanitation–2012 Update, launched on 6 March 2012.

### Further guidance: Tables and Figures

- **Tables** should be set up in Word, referred to as ‘Table’ and numbered consecutively

Table 5 : Difference in accessibility and fees by water source in rural areas

Water type	Proportion	Proportion of household with water source at home	Water expenditures (in x1000 XOF)	Household annual income (in x1000 XOF)
Safe drinking water	0.1163	0.5887	29.07	1405.7
Ground water type 1	0.3959	0.0679	27.69	738.9
Ground water type 2	0.4879	0.3293	28.43	932.5

## SUSTAINABLE SERVICES

### Rural Water Supply Sustainability

Total	1	0.2560	28.13	911.2
Number of Obs. (weighted)	1 819 407			

Table 6 : Water accessibility by area

Area	Distance to water source	Proportion	Proportion of household using fresh water	Household annual income (in x1000 XOF)	Household size	Proportion of poor	Water expenditures (in x1000 XOF)
Rural	At home	0.2681	0.2664	1203.7	5.07	0.4227	25.2
	Less than 5 km	0.7112	0.0606	792.9	5.02	0.5285	28.6
	More than 5 km	0.0206	0.0286	762.6	5.53	0.6099	29.3
Overall	At home	0.4659	0.5863	1957.1	4.88	0.2661	41.5
	Less than 5 km	0.5188	0.1782	929.2	4.86	0.4715	32.4
	More than 5 km	0.0153	0.1726	1281.2	5.34	0.5354	34.7

Table 7 : Determinants of household's water source choice (Multinomial logistic regression)

Variables	Safe water source	Ground water type 1			Ground water type 2		
	Margin	Coef.	Std. Err.	Margin	Coef.	Std. Err.	Margin
Poverty status (Ref = not poor)	-0.0273***	0.4663***	0.1384	0.0289	0.3865***	0.1312	-0.0015
Log of household income	0.0049*	-0.0785*	0.0402	-0.0031	-0.0734*	0.04	-0.0018
Household size	-0.0007	0.0019	0.0192	-0.0028	0.0155	0.0185	0.0034
Gender of household head (Ref = male)	0.0468***	-0.6058***	0.149	-0.0218	-0.5926***	0.1395	-0.025
Age of household head	-0.0001	0.0043	0.0044	0.001*	-0.00004	0.0042	-0.0009
Household members literate	0.0293**	-0.1302	0.2331	0.1088***	-0.6691***	0.22	-0.1382***
Household members with college degree	0.0568***	-0.6981***	0.2679	0.0432	-0.9935***	0.267	-0.1**
House standing (Ref = low standing house)							
High standing house	0.0801***	-0.5256**	0.2112	0.1192***	-1.2375***	0.1988	-0.1994***
Middle standing house	0.0319***	-0.3545**	0.1473	0.0358**	-0.5728***	0.1386	-0.0678***
Type of toilet (Ref = No toilet at home)							
Toilets with flush	0.2295***	-1.4073***	0.342	0.0302	-2.1093***	0.2997	-0.2598***
Toilets without flush	0.0519***	-0.6705***	0.131	0.0065	-0.7946***	0.1249	-0.0584***
Number of rooms in house (Ref = 1 room)							
House with 2 to 4 rooms	0.0034	-0.1037	0.1507	-0.0208	-0.0171	0.1423	0.0174
House with 5 or more rooms	0.0118	-0.122	0.2048	0.0147	-0.2092	0.1971	-0.0265
Distance to water source (Ref = at home)							
Less than 5 Km	-0.0184	0.7632***	0.2516	0.1717***	-0.0114	0.2533	-0.1532***
More than 5 Km	-0.0507***	1.6996**	0.7144	0.2215***	0.8657	0.7168	-0.1708***
Time to water source (Ref = at home)							
Less than 15 minutes	-0.1108***	2.4972***	0.2619	0.3618***	0.8223***	0.2499	-0.251***
More than 15 minutes	-0.0706***	2.4679***	0.4606	0.1687***	1.8918***	0.4559	-0.0981
Region of residence (Ref = District of Abidjan)							
Center north	0.0743**	-0.6485**	0.3041	0.0389	-0.9736***	0.2925	-0.1133***
Center west	0.011	-0.3772	0.2695	-0.079**	-0.032	0.2538	0.068**
North east	-0.0362**	1.1567***	0.4149	0.2186***	0.2934	0.4082	-0.1824***
North	-0.0105	0.4677	0.3505	0.132***	-0.0824	0.338	-0.1215***
West	-0.0124	0.1498	0.3543	-0.0153	0.2402	0.336	0.0277
South	0.0709***	-1.1822***	0.2427	-0.1307***	-0.6855***	0.2267	0.0598*
South west	-0.0223	-0.5355*	0.3102	-0.2476***	0.7939***	0.2805	0.2699***
Center	0.1824***	-1.0924***	0.2727	0.1256***	-2.1471***	0.2796	-0.308***
Center east	0.0566**	-0.9227***	0.2758	-0.1043***	-0.5179**	0.2565	0.0477

## SUSTAINABLE SERVICES

### Rural Water Supply Sustainability

Variables	Safe water source		Ground water type 1			Ground water type 2		
	Margin	Coef.	Std. Err.	Margin	Coef.	Std. Err.	Margin	
Intercept	-	0.9909	0.6175	-	30.4569***	0.5966	-	

Pseudo R2 = 0.226 ; Wald chi2(52) = 1235.26 ; Log pseudo likelihood = -1241806.9; \*\*\*: significant at 1%; \*\*: significant at 5%;  
 \*: significant at 10%; Water source reference = safe drinking water; Margin = marginal effects of multinomial logistic regression

## SUSTAINABLE SERVICES

### Professionalisation of Rural Water Service provision

#### 3.3.2 Professionalisation of Rural Water Service provision

---

## The need for capacity development to enhance rural water supply and sanitation service delivery: The RWSSC/JICA Approach in Nigeria

---

Type: Short Paper (up to 2,000 words)

**Authors:** Martin Obada Edivie & Sani Dauda Ahmed, Rural Water Supply and Sanitation Centre, National Water Resources Institute Kaduna-Nigeria, [martineduvie@gmail.com](mailto:martineduvie@gmail.com) +2348036400061

### Abstract/Summary

A project to improve the capacity of Rural Water Supply and Sanitation Centre (RWSSC) of the National Water Resources Institute, Kaduna and staff of Rural Water Supply and Sanitation Agencies in Nigeria especially those that benefitted from the Japanese International Cooperation Agency (JICA) Aid grant is presented as a model that has increased capacity of the Agencies staff for effective service delivery. The project commenced with the assessment of institutions' capacity and training needs, and stakeholder workshop to consider the results and skill gaps identified. Decisions and actions that will assist in the implementation of the project were agreed with stakeholders. This was followed by the development of nine relevant courses, delivery of trainings to address knowledge and skill gaps and supporting of the institutions with necessary working tools. A total of 567 staff were trained and 2,389 boreholes drilled in rural communities. The project was rated relatively high for enhancing capacity of personnel and making an improvement in rural water supply and sanitation service delivery in Nigeria.

### Introduction

In an effort to improve rural water supply and sanitation in Nigeria, the National Water Resources Institute (NWRI) in collaboration with Japan International Cooperation Agency (JICA) carried out a training and research project in the area of rural water and sanitation known as “The Project for Enhancing the Function of Rural Water Supply and Sanitation Centre for Capacity Development (RWSSC)” in National Water Resources Institute (NWRI). The goal of the Project is to enhance service delivery in rural water supply and sanitation (RWSS) in Nigeria through capacity development of stakeholders.

In response to the realization of the need to assist the Nigerian Government, JICA conducted a preliminary and detailed planning surveys in 2009. Findings of the two surveys indicated need to intervene which resulted in the signing of Record of Discussion (R/D) on 21<sup>st</sup> October, 2009. Consequently, the project commenced and designed to last for 45 months. Capacity of Rural Water Supply and Sanitation Centre established at NWRI and other RWSS institutions at state level was envisaged to be strengthened. The vision of the Centre is to be the hub for capacity development and information dissemination in Rural Water Supply and Sanitation sub-sector in Nigeria. This paper presents activities carried out, findings and achievements made by the project in rural water supply and sanitation sub-sector in Nigeria.

### Methodology/Activities

#### Institutional Assessment (IA)

This aspects of the project focused on assessing the capacity of rural water supply and sanitation institutions in Nigeria. It utilizes the concept of “accelerators and potholes” to identified capacity gaps in the assessed institutions. The gaps were classified under a framework called “SKEAMEE” (SKE = Skills, Knowledge and Experience; AM = Atitude and Motivation; EE = Enabling Environment) and Capacity

## **SUSTAINABLE SERVICES**

### **Professionalisation of Rural Water Service provision**

Development (CD) actions and plans developed to address the gaps. A total of 66 institutions were assessed (16 State and 53 Local Government Area (LGA) institutions).

#### **Accelerators and Potholes**

Based on the position profiling and analysis, the key factors that make various position holders perform their tasks efficiently and the ones that hamper their performance were identified and referred to as accelerators and potholes respectively. Here accelerators are the things that pull towards achieving a goal while potholes stall or stop progress. Progress is made when the accelerators are maximized and the potholes are minimized, or transformed into accelerators.

#### **Training Needs Assessment (TNA)**

This step centred on identifying priority areas of training needs in the assessed institutions. Structured questionnaires were utilized and supplemented with Focused Group Discussion (FGD) with staff supervisors and key officers of the institutions. The Training Needs Assessment assisted in elucidating findings of the Institutional Assessment, and 18 State and 36 Local Government Area institutions were assessed.

#### **Development appropriate training modules and manuals**

Following the conduct of the Training Needs Assessment, nine priority areas of trainings were identified and training modules and manuals developed to cover areas of needs. The manuals were reviewed and standardized in a stakeholders’ workshop.

#### **Training of stakeholders in the rural water supply and sanitation sub-sector**

This step focused on delivering trainings to stakeholders using the modules and manuals developed. The approach comprised participatory and didactic style to deliver trainings. Outreach system and use of centralized locations as venue were employed for the trainings to reduce cost. The out-reach system involves use of subject matter experts to deliver trainings in-house at work place of trainees without taking them out of their duty stations. This system allows practical aspects of the trainings to be harmonized with work activities to ensure that trainings are relevant to actual job performance.

#### **Training Impact Assessment (TIA)**

This centred on evaluating impact of the trainings. The Rural Water Supply and Sanitation Centre ensured that after each training, trainees are monitored through their supervising officers to find out whether the trained staffs have put the new knowledge and insights into practice or not. Post training impact evaluation was also carried out also to determine impact of the trainings using one of the State institutions (Niger State Rural Water Supply and Sanitation Agency (RWSSA) as pilot.

#### **Establishment of effective management system at RWSSCC**

This aspect of the project involves identifying and deploying qualified staff from National Water Resources Institute to the Rural Water Supply and Sanitation Centre to coordinate activities of the Centre. Capacity of the Centre staff was enhanced by the JICA experts through mentoring and conduct of Training of Trainers (ToT) on various aspects of the Centre activities. Administrative, Monitoring and Public Relations (PR) manuals, extension materials and monograms were developed to facilitate service delivery in the Centre. This aspect of the project also include the development and maintenance of a National Water Resources website accessible to stakeholders.

#### **Conduct of applied research**

This aspect of the project centred on conduct of research activities which include:

- Community Led Total Sanitation (CLTS) study in two rural communities (Karuga and UngwarBagudu) located in Chikun LGA of Kaduna State to serve as pilot and model for training on CLTS. Provision of water supply facilities was introduced to slightly differ the approach from the usual CLTS philosophy;
- Hydrogeological assessments, updating and production of hydrogeological maps.



## SUSTAINABLE SERVICES

### Professionalisation of Rural Water Service provision

#### Main Results/Findings

##### Capacity gap

The findings from the assessments showed generally low level of capacity in most of the assessed institutions. Capacity gap linked to Skill Knowledge Experience relate to lack of training, inadequate qualified staff and poor information sharing. Issues around Altitude Motivation include inadequate staff welfare, lack of promotion, poor administrative procedures and poor organizational attitude. While under the Enabling Environment, a general dearth of basic working materials, tools and equipment including lack of functional drilling rigs and absence of enabling law were identified as factors constraining service delivery in most of the institutions.

##### Training needs

A summary of the identified training needs in the assessed institutions is presented in Table 1.

**Table 1: Summary of training needs identified**

S/No	Area of Training Need	Respondents (%)	Priority Level
1.	Geophysical Investigations	57	5
2.	Borehole Geophysical Logging	62	4
3.	Borehole Drilling	69	5
4.	Pumping Test	54	4
5.	Submersible and Hand Pump Installation and Maintenance	86	5
6.	Maintenance of Drilling Equipment	50	5
7.	Water Quality Analysis	75	5
8.	Community Led Total Sanitation	70	5
9.	Basic Hygiene Promotion Techniques	68	4
10.	Community Mobilization and Sensitization	89	5
11.	Sanitation Structures Construction	70	5
12.	Waste Management	58	5
13.	Computer Appreciation	56	4
14.	Computer Appreciation	56	4

NWRI 2010

##### CLTS in Karuga and UngwarBagudu

The implementation of CLTS approach in Karuga and Ungwar Bagudu triggered provision of more latrines for safe sanitation practices and end to open defecation in the model communities. The sanitary facilities (latrines) were provided by the community members themselves through a social awakening and mobilization using CLTS approach. Due to lack of safe water, the communities were provided with two (2) boreholes - one for each of the communities (Figure 3).



## SUSTAINABLE SERVICES

### Professionalisation of Rural Water Service provision

Sanitary facility built by a community member



Water supply facility provided in UnguwarBagudu

**Figure 3: Implementation of CLTS in Karuga and UnguwarBagudu**

### Towards Addressing the Capacity Constraints and Achievements

#### Development of Capacity Development actions and plans

As a step towards addressing the identified capacity constraints in the assessed institutions, Capacity Development actions were developed that can minimize the potholes and maximize accelerators. Capacity Development actions and plans were developed in conjunction with respective institutions' staff to address the capacity gaps. The Capacity Development actions and plans covered the three major areas Skill Knowledge Experience, Altitude Motivation, and Enabling Environment. In the plans, priority levels were allocated to each Capacity Development action for implementation by the assessed institutions and other stakeholders.

#### Passing of enabling Law for some Rural Water Supply and Sanitation Agency Institutions

As part of outcome of the Institutional Assessment , enabling Law for establishing some of the States Rural Water and Sanitation institutions to operate as full Agencies with autonomy for providing rural water supply and sanitation services were passed by their respective State Government and Assembly. This was particularly an issue for Kaduna, Imo and Nasarawa Rural Water Supply and Sanitation institutions. The effort has resulted in the transfer of all mandated functions of rural water supply and sanitation from parent and line ministries to the Rural Water Supply and Sanitation Agencies (based on the enabling law). This was imperative for the Rural Water Supply and Sanitation Agencies to be visible and recognized as credible organizations for rural water supply and sanitation services delivery in Nigeria.

#### Implementation of training programmes and impact

The standardized training manuals developed were utilized for training of stakeholders (Figure 1). The manuals and trainings include:

- Groundwater Investigations Techniques (General methods and Geophysical Surveys)
- Borehole Construction and Completion
- Drilling Technology
- Hand pump Installation, Operation and Maintenance
- Borehole Rehabilitation and Maintenance
- Alternative Water Supply Sources Development (Hand dug well, Spring Development & Rainwater Harvesting)
- Drilling Machinery Maintenance Technology
- Sanitation and Hygiene Practices
- Community Mobilization and Sensitization

SUSTAINABLE SERVICES

Professionalisation of Rural Water Service provision



Figure 1: Some training activities and facilities provided during the Project

A total of 29 training sessions were carried out between 2011 and 2014 under the project, and 567 participants have benefited from different trainings of the RWSSC across Nigeria (Figure 2) especially the JICA Grant Aid focus States, Federal establishments and the private sector.

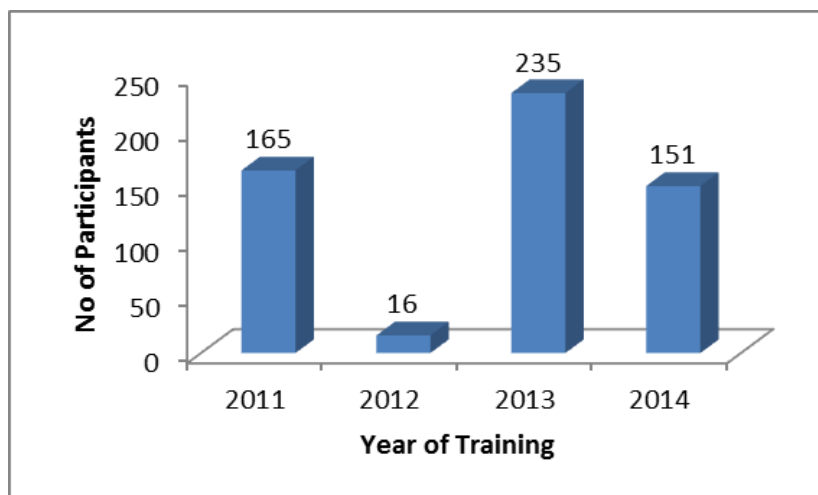

Figure 2: Summary of trainings conducted by RWSSC (2011-2014)

Based on analysis of the training impact evaluation, comments by the trainees supervisors indicate improvement in the execution of geophysical survey, borehole drilling, pump installation, machinery maintenance, sanitation and hygiene practices and community mobilization and sensitization.

**Supporting Rural Water Supply and Sanitation institutions with machinery and equipment by JICA**

Machinery and equipment comprising drilling rig, compressor, service trucks, drilling accessories and other groundwater exploration equipment were provided for effective service delivery, training and research under the JICA project. The RWSSAs supported include Bauchi, Enugu, Kano, Katsina, Kebbi,

## SUSTAINABLE SERVICES

### Professionalisation of Rural Water Service provision

Ondo, Oyo, Taraba and Yobe Rural Water Supply and Sanitation at state level and Rural Water Supply and Sanitation Centre at federal level.

#### Boreholes planned and completed during the JICA Project

In order to assess impact of the project and targets in terms of total number of boreholes drilled and counterpart funding for materials, allowances and operations provided to the States RWSSAs to achieve targets, an evaluation was conducted. Table 2 shows the summary of targets and achievement made.

**Table 2: Boreholes Planned Targets and Achievement by States during the JICA Project**

S/No	State	Target No. of Boreholes	Total No. Drilled	% Achieved	Remarks
1	Oyo	100	1,358	over 1000	4 Years period
2	Kano	240	403	168	
3	Yobe	98	98	100	
4	Katsina	92	185	201	
5	Bauchi	76	86	113	
6	Niger	100	59	59	2 Years Period
7	Ondo	100	15	15	Lack of counterpart funds
8	Enugu	100	50	50	
9	Taraba	100	98	98	
10	Kebbi	100	37	37	

From Table 2, target for the project in terms of boreholes to be drilled during the project period entails the construction of 1,106 boreholes in Ten (10) States. Records shows that the States RWSSAs constructed a total of 2,389 boreholes representing over 208 % achievement. Prior to the project, borehole drilling were not effective in most of the States.

#### Conclusions and Recommendations

Analyses of the evaluation revealed that 96.6% of the trainees rated the training methods as appropriate and trainer’s skills have improved through the ToTs. Trainings are reviewed based on Plan-Do-Check-Act (PDCA) cycle and management of the Rural Water Supply and Sanitation Centre is highly improved service delivery. Some of the lessons learnt include the need to define source of funding from the start of projects, the age of Counterpart staff should be considered to avoid early exit of such staff after undergoing trainings. Procurement of equipment need improvement to avoid delay in arrival of such equipment for trainings and project activities.

The project recommends continuous institutional and training needs assessment, transfer of skill/knowledge to younger generation, possible replication of this project in other developing countries and increase in budgetary allocation to achieve sustainable implementation of rural water supply and sanitation and socio economic development of Nigeria and other developing countries.

Key word: **Capacity development, rural water supply, sanitation, groundwater**

#### Acknowledgements

The author would like to extend thanks to the Management of National Water Resources Institute Kaduna Nigeria and JICA for the opportunity to participate and act as the Coordinator RWSSC and Project Manager of the project.

#### References

## **SUSTAINABLE SERVICES**

### **Professionalisation of Rural Water Service provision**

NWRI/JICA (2010) Project for enhancing the Function of Rural Water Supply and Sanitation Centre for Capacity Development in National Water Resources Institute (RWSSC Project in the Federal Republic of Nigeria. Inception Report March 2010.

NWRI/JICA (2014): Evaluation Reports-Mid-Term and Final Reports 2014.

NWRI (2010): Institutional Assessment in States and LGAs. National Water Resources Institute Kaduna

## SUSTAINABLE SERVICES

### Professionalisation of Rural Water Service provision

---

# De la théorie à l’Opérationnalisation de la Reforme de la gestion des Services d’Eau

---

Type: Article court

**Auteurs :** AGOIGNON Fabrice, *Assistant technique, IRC Burkina.* [agognon@ircwash.org](mailto:agognon@ircwash.org), Tel. 00226 75755559

### Abstract/Résumé

Dans le cadre de l’amélioration des services d’eau potable en milieu rural et semi-urbain au Burkina Faso, IRC a revisité le cadre de suivi-évaluation élaboré au niveau national et qui s’est révélé inopérant au niveau communal en raison de la complexité de mise en œuvre, n’étant pas adapté au niveau de compétence disponible à cette échelle. On note également une insuffisance du dispositif national de suivi-évaluation affectant particulièrement les autorités communales. En effet, les responsables communaux ne disposent pas de mécanisme local de suivi des performances du service public d’eau potable dont elles assument la maîtrise d’ouvrage. En conséquence, le secteur de l’approvisionnement en eau potable se retrouve sans suivi ; les AUE qui constituent le cœur du dispositif ne disposent pas des capacités nécessaires pour jouer leurs rôles et légitimer leur existence au niveau national. Après six années de mise en œuvre, le dispositif de gestion des services d’eau potable s’est effondré, en raison des capacités insuffisantes de l’ensemble des acteurs et d’une absence de suivi.

La simplification du suivi communal a consisté, d’une part, à examiner des indicateurs et à sélectionner ceux véritablement déterminants dans le suivi régulier des services et, d’autre part, à analyser les sources d’information, en ne retenant que des structures existantes. Il s’agit des plateformes suivantes:

- Les rencontres trimestrielles entre les gestionnaires de PMH et le Bureau exécutif des AUE ;
- Les assemblées générales semestrielles des AUE ;
- Les rencontres mensuelles entre le technicien communal AEPA et les maintenanciers.

Une fois élaboré, ce cadre de suivi-évaluation des services d’eau potable a été expérimenté dans deux communes de la région du sahel. Cette petite échelle d’expérimentation a permis d’analyser les contours de la mise en œuvre, d’étudier les coûts et les modalités de financement. Les résultats obtenus montrent qu’il est possible de suivre efficacement les services d’eau en s’appuyant sur les compétences communales qui, avec un appui adapté, seraient en mesure de mener à bien une telle activité capitale pour la pérennité du service.

### Introduction

La Direction Générale des Ressources en Eau (DGRE) du Burkina Faso a développé en 2007, un cadre très élaboré de suivi évaluation du PN-AEPA. L’ambition de cet outil est de constituer le cadre national de suivi-évaluation du service public d’eau potable au Burkina Faso intégrant le milieu urbain, les milieux semi-urbains et ruraux. Cependant, à la mise en œuvre, on observe que ce dispositif ne fournit qu’une appréciation limitée au niveau national des performances des services publics d’eau potable en milieu rural et semi-urbain. On note d’autre part que cette insuffisance du dispositif national de suivi-évaluation affecte particulièrement les autorités communales. En effet, les responsables communaux ne disposent

## SUSTAINABLE SERVICES

### Professionalisation of Rural Water Service provision

pas de mécanisme local de suivi des performances du service public d'eau potable dont elles assument la maîtrise d'ouvrage.

Le principal défi étant d'assurer la pérennité du service, il est indispensable de mettre en place un système de suivi qui, tout en respectant la réglementation, puisse être mis en œuvre aisément par les structures communales à différents niveaux et donc répliquables à l'échelle régionale et nationale. Pour cela, il est indispensable que le suivi-évaluation renforce les compétences communales telles que le Comité Communal Eau et Assainissement (CCEA) et le Technicien Communal (TC-AEPA) et s'organise autour des organes et instances existant dans la commune. Le second défi est que les coûts induits par le suivi-évaluation soient à la portée du secteur.

Pour étudier la faisabilité du suivi-évaluation, IRC a mis en œuvre, dans le cadre du programme USAID-WAWASH, un processus de recherche-action, de juin 2013 à juin 2015. L'objet de ce processus est de concevoir, d'expérimenter et de présenter des propositions fondées sur les résultats, qui puissent être directement répliquées à l'échelle nationale. Ce processus a été conduit en collaboration étroite avec la DGRE, la Direction Régionale en charge de l'eau potable dans la région du Sahel, les communes de Gorgadji et d'Arbinda.

#### Contexte, objectifs et activités

L'accès continu à une eau potable en milieu rural reste un défi majeur au Burkina. Les indicateurs d'accès à l'eau potable restent faibles (58,5 % en milieu rural, DGRE, 2010), malgré les efforts consentis par le secteur. Parmi ces efforts, le gouvernement a réformé le système réglementaire afin de rendre plus efficace la fourniture d'un service accessible, financièrement viable et reconnu par les populations concernées en milieu rural et périurbain. Cette réforme est pilotée depuis 2008 dans diverses régions du pays, dont la région du Sahel et pose les bases des responsabilités des communes, maîtres d'ouvrage du service d'eau potable depuis la mise en œuvre de la décentralisation (en Décembre 2004). Chacune des 302 communes rurales est désormais responsable de la fourniture d'eau potable, via des Association d'Usagers de l'eau (pour les PMH) ou par le biais d'un exploitant privé (AEPS). Les communes s'approprient leurs responsabilités de façon progressive, à la hauteur de leurs capacités et de leurs ressources. La réforme met également en place le cadre opérationnel de l'exploitation des ouvrages à l'échelle villageoise via les associations d'usagers de l'eau (AUE) et les fermiers.

L'objectif du suivi-évaluation communal, tel que pensé dans le PN-AEPA, est de mesurer périodiquement les performances du service public d'eau potable et d'utiliser ces informations pour améliorer les décisions des autorités publiques et opérateurs en vue de l'amélioration du service. Conformément au cadre conceptuel du suivi évaluation du PN-AEPA, le suivi évaluation communal s'intéresse à l'atteinte des résultats du PCD-AEPA ainsi que la pertinence, l'efficacité, l'efficience et la pérennité des actions menées.

Les analyses qui en découlent nourrissent le processus de réflexion aussi bien au niveau communal, dans le suivi régulier du service; qu'au niveau national. Du point de vue du processus et du contenu, le suivi-évaluation de l'eau potable consiste à suivre les éléments suivants :

- La qualité des services, du point de vue de la satisfaction des usagers et des performances des structures de gestion du niveau communautaire (AUE) au niveau communal ;
- Le coût des services à long terme et le recouvrement de ces coûts ainsi que leur maîtrise/efficience.

#### Résultats principaux et leçons tirées

## SUSTAINABLE SERVICES

### Professionalisation of Rural Water Service provision

Dans le cadre de la mise en œuvre de cette action, on peut citer au titre des résultats atteints :

1. L'élaboration d'un cadre de suivi-évaluation des services d'eau potable en collaboration avec les structures en charge du secteur de l'eau au niveau national, régional et locales ainsi que les partenaires.  
Ce cadre s'inspire du dispositif élaboré par les autorités compétentes mais le réduit à sa plus simple expression, ne gardant que les indicateurs indispensables au suivi des services au niveau communal et en rendant leur renseignement accessible au niveau de compétence dont on peut disposer dans une commune rurale type. La collecte des informations devant permettre le suivi se fait d'une part à travers des instances endogènes (1) Rencontre mensuelle entre le technicien communal et les maintenanciers de PMH ; 2) Rencontre trimestrielles entre les membres des bureaux exécutifs des Associations des Usagers de l'Eau au niveau village (AUE) ; 3) assemblée générale semestrielle des AUE et d'autres part avec des compétences existantes au niveau communales 1) Technicien communal 2) Comités Communaux de l'eau et de l'Assainissement (CCEA)
2. La redynamisation des structures locales de gestion des services d'eau potable que sont les AUE et les CCEA dans les deux communes où l'action a été conduite.
3. L'amélioration des performances du service d'eau potable : 1) Maîtrise de l'étendue du parc hydraulique et de son état réel par les autorités communales ; 2) Réduction de la durée des pannes de 8 jours à 3 jours dans une commune et de 5 jours à 2 jours dans l'autre commune ; 3) Paiement de la redevance par les AUE, ce qui garantit le suivi semestriel des ouvrages par le maintenancier et à terme, le développement des services à travers le financement du suivi.
4. Cette section rend compte des coûts comptabilisés lors de la mise en œuvre du système dans les deux communes au cours des 2 dernières années et identifie des sources de financement potentiels pour couvrir ces coûts à long terme. La détermination des coûts du suivi communal des services d'eau potable, la compréhension des coûts de mise en œuvre du système de suivi évaluation, ainsi que l'identification des sources de financement pérennes constituent une étape décisive pour son adoption par d'autres communes et le passage à l'échelle nationale. Ces coûts intègrent la formation des acteurs, la collecte et le traitement des données, la rédaction des rapports de performance et le partage des résultats avec le conseil communal.

### Conclusions et Recommandations

La mise en œuvre du suivi communal des services de l'AEP a permis de connaître l'état des PMH ainsi que celui du service de l'eau potable sur le territoire communal. Dans l'ensemble, les résultats permettent de tirer les constats majeurs suivants :

Le suivi a également permis d'évaluer la proportion des usagers satisfaits sur certaines dimensions du service public de l'eau.

L'intérêt du suivi communal des services d'eau potable réside dans le fait qu'il permet de diagnostiquer de façon objective le dysfonctionnement du service et de faciliter la recherche d'actions palliatives pour permettre aux populations d'avoir accès à des services d'eau pérennes et de qualité. Par voie de conséquence, il améliore la coordination communale à travers l'élaboration systématique de plans d'actions annuels du secteur.

Dans la perspective de rendre pérenne l'accès aux services d'eau potable, la mise à l'échelle du dispositif de suivi, repose sur l'identification de sources pérennes de financement, au niveau communal en premier lieu, mais également régional et national. La principale source de financement au niveau communal étant les redevances perçues sur les PMH dont 60% sont destinés au suivi préventif et le reste au suivi. Mais en général, ces montants ne suffisent pas à financer les coûts du suivi. Toutefois, il faut noter que les coûts d'appui technique représentent environ 80% des coûts totaux. On pourrait envisager que ces coûts se réduisent au fil du temps, au fur et à mesure de la mise en capacité des AUE, du CCEA et le technicien communal

### *Mentions*



## SUSTAINABLE SERVICES

### Professionalisation of Rural Water Service provision

*Cette action a été menée dans le cadre du Projet Triple-S (Sustainable Service at Scale) financé par le Programme WA-WASH de USAID avec l'appui technique des structures étatiques (Direction Générale des Ressources en Eau, Direction régionale de l'Eau et de l'Assainissement du Sabel) et les communes (Arbinda et Gorgadji)*

## SUSTAINABLE SERVICES

### Professionalisation of Rural Water Service provision

# Sustainability Services through Quality Design & and Construction plus effective Operation & Maintenance

Type: Short Paper

**Authors:** *Akab Henry Ndab, Technical Director, Integrated Engineering Associates Ltd, Cameroon, ndabhenny@yahoo.com, (+237) 777787102*

### Abstract/Summary

The challenges of the drinking water sector in the rural areas of Cameroon are increasingly how to ensure that the coverage already achieved can be maintained and their lifespan prolonged. Many water schemes (wells with hand pumps, gravity schemes, etc.) are functioning unreliably or break down after a short service life. Systematic analysis has shown that the reasons are found at two levels: a) in-appropriate design and poor construction quality and, b) lack of preventive maintenance and unprofessional repairs.

In responding to these challenges IEA(Integrated Engineering Associates) in cooperation with Skat Foundation and in consultation with government institutions, the private sector and community organizations have developed corrective measures in the following two areas: a) **development of a series of training modules** that cover design, practical implementation, operation & maintenance management including training of trainers and trainers guide and, b) **development and implementation of appropriate Operation & Maintenance models** that consider the principles of subsidiarity, accountability and efficient management, supportive rules & regulations that are in line with the legal framework and water policy of the country, clarity of roles, responsibilities and competences and sustainable financing system. The two interventions are interlinked in that any missing capacities in O&M management lead to additional training modules

### Introduction

The government of Cameroon has shown a willingness to improve the water services in rural areas through legislation and partnerships that seek to regulate and focus the actions of all stakeholders involved in the sector. Under Cameroon's Water Law (Law No. 98/005 of 14 April 1998) water is a natural resource to be enjoyed by all the citizens of the nation. The state is responsible for managing the country's water resources and facilitating access for the entire population. However, the Water Law expresses the state's intentions to transfer the responsibility to manage water resources to local authorities and other entities. The competences for rural water supply have been devolved to local councils as per the law on decentralisation. Unfortunately the corresponding financial resources have not yet followed. The lead role of the local Council, as the closest administrative body to the communities remains at the centre stage. With the ongoing process of decentralisation, as regulated by Law N° 2004/017 of 22nd July 2004 on the Orientation of Decentralization and Law N° 2004/018 of 22nd July 2004 to lay down rules applicable to Councils, competences for basic services have been devolved to the councils amongst which is the responsibility to provide reliable water services to villages.

In 2007, the government adopted a rural Drinking Water Supply and Sanitation Sector (DWSS) policy and a 2008–2015 action plan to achieve 80% rural coverage by 2015 through increased investment in infrastructure development and rehabilitation and institutional development. Today project implementation is still rounding up implying the ambitious 2015 target was not achieved. In addition the JMP(Joint Monitoring Programme) trend for rural water shows that the coverage of improved sources for rural water as updated in 2015 still stands at 53%(WHO/UNICEF,2015).

## SUSTAINABLE SERVICES

### Professionalisation of Rural Water Service provision

The Cameroon Water Partnership (also known as the Global Water Partnership–Cameroon) is a multi-stakeholder body formed in 2005 to work with the government to develop policy and programs for the sustainable management of the country’s water resources as a contribution to alleviating poverty, improving socioeconomic well-being and protecting natural resources. The Partnership is a regional branch of the Global Water Partnership, which was founded in 1996 with support from UNDP and the World Bank. The network is open to all organizations involved in water resources management, including governments, donors, agencies and the private sector. The Partnership provides a forum for dialogue and exchange of information for all stakeholders in the water sector and supports capacity building and training of stakeholders in the water sector on principles of integrated water resources management. This partnership is a tacit recognition by the government that all partners need to learn from any shortfalls in the past and find a common way forward so as to improve on the water services. This will lead to increased advocacy, new policy orientation, supportive legislation, alternative financing, capacity building etc.

Much is still to be desired as these efforts do not seem to have taken the rural communities out of the perpetual cycle of water crises, 53% coverage (WHO/UNICEF, 2015). System failure has not been arrested as design and implementation quality has not improved and the appropriate operation and maintenance model has not been developed and adopted.

The initiative by IEA and Skat Foundation is therefore a complementary contribution to government efforts that will bring in some corrective measures for the improvement of rural water services in the areas of a) **development of a series of training modules** that cover design, practical implementation, operation & maintenance management including training of trainers and trainers guide and, b) **development and implementation of appropriate Operation & Maintenance models**.

### Description of the Case Study – Approach or technology

The aim of this project is to provide a tangible contribution to improve on water services within the municipalities through the **development of a series of training modules** that cover design, practical implementation, operation & maintenance management including training of trainers and trainers guide as well as the **development and implementation of an appropriate Operations and Maintenance (O&M) model** for the council that is effective and sustainable by involving, in a participatory manner, the right stakeholders who are trained and empowered to fulfill their responsibilities with the support of a legal framework that can be readily enforced.

The project process involves the need identification, the selection of pilot councils, the development of suitable management model, the implementation of the management model and the up-scaling of the process.

The project fits in line with the efforts made by the international community, the government, local councils, the legislature of the state of Cameroon as well as the beneficiary communities. Accordingly the efforts of Skat Foundation and Integrated Engineering Associates in this project are all aiming at reaching reliable and sustainable rural water supply services. We have sort to understand and make use of the lessons learnt from the past, avoid patch work, analyse the challenges and develop the responses together with all stakeholders concerned (consumers, village and municipal organizations, NGOs and private sector, regional and national level). Our role as facilitators ensured that all key players actively contributed to the debate while remaining focused on the policy orientation of the government and the legal framework. Furthermore we have remained realistic by starting on a small scale in a region with highly motivated municipalities and villages and follow a bottom up approach with involvement of higher levels of government from the beginning.

## SUSTAINABLE SERVICES

### Professionalisation of Rural Water Service provision

Both interventions are documented in form of guidelines and tools to facilitate scaling up and to ease replication probably with required adaption to prevailing contextual situations.

Prior to the development and implementation of an appropriate Operations and Maintenance (O&M) model for the council, several training modules had been developed for the training of technicians involved in the supervision and implementation of rural water supply projects as a contribution to upholding quality standards in the design and construction of water schemes. So far the following modules have been developed and tested:

- Raw materials
- Concrete mix (mix design)
- Stone masonry
- Reinforce concrete
- Plastering/topping
- Design and construction of a spring catchment
- Caretaker Training

Each module has been developed with a trainers guide and a handbook for the trainees, thus facilitating replication. The missing capacities in O&M will lead to the development of more modules.

The pilot phase for the development and implementation of an appropriate Operations and Maintenance (O&M) model for the council, involves two selected councils of the North West Region of Cameroon. Fundong Council and Jakiri Council were selected based on the selection criteria developed at a need assessment forum, Workshop No. 1.

A cross section of Mayors, development actors of the water sector of the region came together to diagnose and chart a way forward for the declining water services(the increasing number of complaints from the various communities to the council) at Workshop No. 1. The recommendations of Workshop No. 1 highlighted the need for an appropriate operation and maintenance model to halt and even reverse the declining functionality of existing systems.

The workshop further established a selection criteria for two pilot Councils for the development and implementation of an effective and sustainable operation and maintenance model at Council level. A steering committee that oversees the process was established in each of the Councils selected. The Mayor together with the steering committee and assistance of the facilitator (Integrated Engineering Associates) organised Workshop No. 2 that brought together all the stakeholders involved in rural water supply of each of the Council areas. The workshop deliberated in workgroups on the key factors affecting operation and maintenance:

- a. O&M management system/institutional set up and legal aspects(statutes) including their enforcement
- b. Finances: O&M cost (routine O&M, repairs, rehabilitation) water fees and tariffs
- c. Role and responsibilities in O&M at village level(consumers, WMC(Water Management Committee), caretakers)
- d. Role and responsibilities at Council and Regional level as well as the private sector and CBOs(Community based Organisations)
- e. Catchment protection issues and enforcement.

The recommendations of the workgroups were then assigned to a taskgroup for the development of an appropriate operation and maintenance model for the Council. The report of the taskgroup was the subject of validation by Workshop No. 3. Workshop No. 3 once again grouped all the stakeholders of the

## SUSTAINABLE SERVICES

### Professionalisation of Rural Water Service provision

water sector of the selected Councils. The outcome is the validation of three tools for the support of an efficient and sustainable O&M model at Council level:

#### **Tool 1: O&M Conceptual Framework**

It provides comprehensive information about the development and implementation of a sustainable O&M model for rural water supply at Council level.

#### **Tool 2: O&M By-laws**

It provides the framework to support the implementation and enforcement of the officially legalized regulations (statutes).

#### **Tool 3: O&M Task list, Job description, Guidelines and Checklists**

This tool is composed of the task list, job description, guidelines and checklists that instruct about all required O&M activities.

As a follow up to the development of the O&M model, training and capacity building was organised for the WMCs and Caretakers of the selected pilot Councils.

In the same light three pilot schemes were selected from each of the two pilot Councils for the implementation of Hotspot rehabilitation. This will go a long way to foster the spirit of participation and ownership of the scheme by the consumers.

#### **Replication**

The interventions are documented in form of guidelines and tools to facilitate scaling up and to ease replication probably with required adaption to prevailing contextual situations Skat Foundation is ensuring the publication of the project documents and tools in line with the strategic field of initiation and implementation of innovative projects in support of knowledge and experience sharing and capitalization .

#### **Main results and lessons learnt**

The expected outputs are:

Though the development processes are still on-going first effects can already be observed.

- Skilled mason and technicians are available to and are in high demand for contractors and council services. The Council technician for Tubah Council successfully, with the support of the council and contributions from the communities rehabilitated three catchments within the municipality which were already considered as hopeless cases. The Caretaker for Weh Water Supply Scheme together with the community, supported by the Water Management Committee successfully brought back their catchment into full function after removing roots that had chucked and damaged the filter material and causing water to escape. Three storage tanks have been successfully rehabilitated by local builders in Ndzeschaa, Kitchoo and Ngomrin supervised by the Jakiri Council technician.
- The management model has been clearly defined with clear roles and responsibilities assigned to the different stakeholders. Facilitated by the community mobilisation and action centre and supported by the Council, several water management committees in the Jakiri Municipality have been reorganised following the application of the limits for mandates as provided for in the statutes.
- Drinking water supply services are improving (less interruptions, shortened response time, etc.) accordingly willingness to pay water rates is improving. Less complaints are registered by the two Councils on potable water issues.
- Improvement in the collection of water fees. In Sop village water fees collection has moved from 40% to 95% following the reorganisation of the Water Management Committee.

#### **Key lessons learnt include:**

## SUSTAINABLE SERVICES

### Professionalisation of Rural Water Service provision

- Training becomes most effective if theory is combined with practical application.
- Operation and maintenance has a good chance to become effective if the stakeholders concerned are directly involved in the development of effective O&M models while the supporting agencies act as process facilitators and resource persons
- Enough momentum can be built up at regional level to enable the lobby for effective O&M for village water supply projects that will safeguard the investments that have been pumped into this sector over the years. In this light more pilot Councils will act as examples and build up the critical mass that will promote up-scaling.

### Conclusions and Recommendations

The process turned out to be a kind of renaissance for village water supplies of the selected Councils. It brought together all the actors of the sector that matter. This interaction break a lot of barriers and created a synergy for the improvement of the sector. An atmosphere of antagonism and apportioning of blame was quickly turned into one of collaboration and responsibility.

As the platform of collaboration has been set, regular consultations should be organised to maintain the momentum and consolidate an effective lobby at Council level that will serve as the breeding ground for a lobby at the regional and national level.

The training modules and the development and implementation of O&M model at Council level has rekindled the culture of quality in design and construction work as is reflected in the quality of construction work carried out by BTC-technicians(Building Training Centre), some of which are over 45 years old today and still intact. A new era for quality standards has therefore been opened.

- The Council should make budgetary allocations that would permit the organisation of regular water platforms at council level.
- The Council should engage a documentation process of all water supply schemes within the Council area.
- All potential spring sources should be identified and protected for future use.
- The Councils should assist communities in the ownership rights over water catchment areas.

### Next steps and plans for the future:

- Monitoring performance and impact.
- Development of additional training modules e.g. 2017 “Design of simple maintenance friendly rural water supplies”
- Completion of documentation O&M model development (process and tools);
- Scaling up of O&M model at council and regional level (following demand)
- Experience and knowledge sharing at local and international level through local networks and in particular through RWSN

### References

- The President of the Republic of Cameroon (1998) “Law No. 98/005 of 14 April 1998 – Water Law”  
The President of the Republic of Cameroon (2004) “Law N° 2004/017 of 22nd July 2004 on the Orientation of Decentralization.”  
The President of the Republic of Cameroon (2004) “Law N° 2004/018 of 22nd July 2004 to lay down rules applicable to councils.”  
Prime Minister’s Office(2001) “Decree N° 2001/163/PM of 8 May 2001 regulating the Perimeter of Protection of the Sources of Water and Treatment of Water Stored for potable use”  
Prime Minister’s Office(2001) “Decree N° 2001/162/PM of 8 May 2001 fixing the modalities of Designation of agents for surveillance and control of water quality”.  
Cameroon growth and strategic paper  
WHO/UNICEF(2015) “Joint Monitoring Programme for Water Supply and Sanitation”  
AMCOW(2011) “Country Status Overview, Water Supply and Sanitation in Cameroon”

## SUSTAINABLE SERVICES

### Professionalisation of Rural Water Service provision

# Customers in focus: Strengthening social and financial sustainability of small town water supply in Northern Vietnam

Type: Short Paper (up to 2,000 words)

**Authors** Riikka Seppälä, *Communications Adviser, Water Supply and Sanitation Program for Small Towns in Vietnam, (Finland)* [riikka.m.seppala@gmail.com](mailto:riikka.m.seppala@gmail.com), tel. +358445944205

## Abstract/Summary

The paper describes the objectives, main results and lessons learned regarding service provision development undertaken in cooperation with small town water supply operators in 22 small towns in Northern Vietnam. Water and Sanitation Program for Small Towns in Vietnam (WSPST) is a 12-year development co-operation program between Vietnam and Finland that provides financial support and technical assistance for the construction, operation and maintenance of water supply (and sewerage) schemes. Quality service provision remains a challenge on national scale. However, during WSPST program, water supply operators have shown positive development in their understanding on the importance of listening to customers' wishes and being active in promoting a change in local residents' water consumption habits.

## Introduction

Water and Sanitation Program for Small Towns (WSPST) in Vietnam includes 25 small towns in Northern Vietnam and comprises 22 water supply projects. The utilities function as branches of state-owned provincial water supply companies. The total number of customers benefiting from the services is over 150,000 people. The program is spread over eight provinces, some of which are remote ethnic minority areas. The program towns are small towns of 4,000-16,000 inhabitants. There are about 640 such towns in Vietnam, and only about 10-15% of them have acceptable water service (World Health Organization, 2011).

In the last phase of the program, from November 2013 onwards, a social marketing approach, focused on advertizing tap water as a safe, reliable and attractive source of water to residents in the towns was adopted. Social marketing can be defined as “*marketing approaches to match available resources with social needs. Social marketing may be applied to service provision and use, the development and acceptance of products, or the adoption of new behaviour. It can be product or behaviour – focused*” (United Nations Human Settlements Program UN-HABITAT, 2006).

In the context of the program, the technical assistance focused on giving training and workshops to water utility staff in marketing their services and growing their customer base to ensure financial and social sustainability of the services. The utilities then proceeded to plan and implement their own marketing campaigns, many through loudspeaker broadcast campaigns, flyers, household visits and public meetings.

The main reason why customer service development and social marketing was brought in WSPST third and final phase, was that customer bases in many towns remained insufficient to ensure coverage of investment and operation and maintenance costs through revenues. There was also a fear that tap water would not be socially accepted, as in many areas stream water and other (increasingly polluted) natural water sources were still widely used, mainly because they are free. As opposed to the traditional information, education and communication (IEC) activities of spreading information about why not to use natural water sources, the social marketing approach took as a point of departure the branding of tap water as “the water of the future” – related to concepts such as modernity, better living standards, quality

## SUSTAINABLE SERVICES

### Professionalisation of Rural Water Service provision

service. The water utilities were trained on the basics of marketing, and in cooperation with local authorities and mass organizations, planned and carried out campaigns encouraging residents to connect to tap water supply.

In Vietnam, the motivation of service providers to develop efficient customer services or financial sustainability has traditionally been low. In the beginning of WSPST program, per capita water consumption, acceptance of tap water services and thus cost recovery was poor. Most of the potential customers relied on and trusted traditional water sources (untreated water) more than tap water. From the beginning of phase III of the program, connection rates have increased from 43% to 102% of the detailed design (WSPST, 2016).

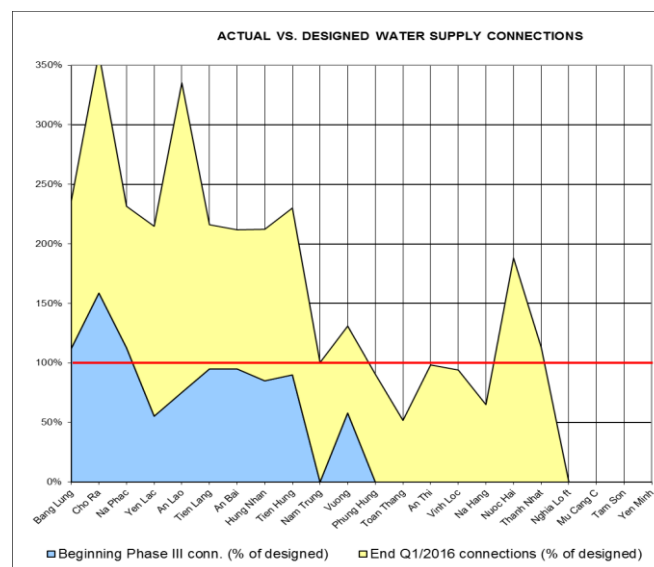

Figure 1: Actual vs. designed water supply connections

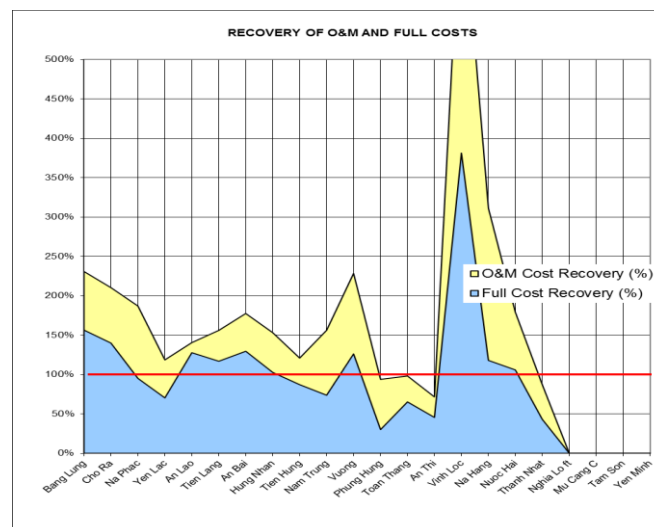

Figure 2: Recovery of costs

The last phase of WSPST set out to engage more tap water users, and also to strengthen ties between service providers and users. The objective was to work with both supply and demand side; customers redefine their identity as consumers, operators build professional pride and increased awareness of what customers want. The project document for phase III outlined this as: “More emphasis will be put on the social marketing to supplement awareness raising and information, education and communication



## SUSTAINABLE SERVICES

### Professionalisation of Rural Water Service provision

methods by social marketing approach, in order to promote connection to water supply and sewer networks and to enhance behavioural changes” (WSPST, 2013).

There were some previous cases of social marketing approach used in Vietnam, with promising results. For example, the International Development Enterprises (IDE), with the support of Interchurch Organization for Development Cooperation (ICCO), started promoting the use of hand pumps and tube-wells in rural Vietnam for both garden irrigation and domestic water supply in 1995: *“In the start-up phase of the project, IDE conducted rural marketing including meetings to motivate hamlet and union leaders, group meetings of potential customers, self employed sales agents, open-air display stands at rural marketplaces, rural video shows, posters, and leaflets to stimulate sales throughout the countryside”* (International Development Enterprises Vietnam, year unavailable). Water and Sanitation Program under the World Bank had also positive experiences of the approach in sanitation in the early 2000s (WSP, 2002).

### Description of the Case Study – Approach or technology

Social marketing of water supply services was used to improve social and financial sustainability of the schemes through strengthened ties between customers and providers, so that customers had greater awareness of their right and responsibilities and that water service providers were more accountable and responsive to their customers. The idea was not to focus on spreading information about risks of using untreated water, but to tap into customers’ hopes, wishes and conceptions of quality water supply.

Financial sustainability was to be attained through increased tap water connection rates and increased per capita consumption, as customers would gradually shift from using risky water sources to using tap water for all purposes. At the same time, social sustainability was to be improved by way of increased satisfaction with the services, and enhanced awareness about who is behind service provision, with what objectives, and what customers can expect from operators.

All water supply service providers were trained in 2014 and 2015 on basic principles of good customer service and basics of marketing. A road map was developed in cooperation with them on how to implement basic customer service and marketing mechanisms in each branch office. These included:

- a customer feedback/complaints mechanism (usually a paper-based logbook),
- guidelines for responding to feedback and suggestions within one week,
- improving billing practices by issuing a paper bill with contact information,
- visiting households to spread information about the schemes,
- sharing water quality results with customers,
- informing customers in advance of interruptions,
- processing new connections promptly,
- mapping out new potential clients and areas to extend the service,
- developing basic marketing materials and branding (uniforms, logo).

Marketing campaigns were carried out by service providers through loudspeaker broadcasts, attending residential group meetings, and sharing marketing materials and customer gifts like calendars with water bills. Most of the staff in small town water supply companies attended the training courses, and they had to practice by role-playing customer service scenarios (based on real-life situations).

Customer consultation has so far been carried out by the technical assistance consultant, but the service providers have assisted and participated in gathering the data. Customer satisfaction surveys have been carried out in all the water supply schemes of the program.

### Main results and lessons learnt

## SUSTAINABLE SERVICES

### Professionalisation of Rural Water Service provision

Over 150,000 customers are served by improved water supply. In most program towns the community attitudes have been strongly in favour of water supply service improvement. Paying a fair price for good water supply service also has been generally accepted. Water tariffs are set by the provinces, so water utilities cannot regulate the price of water, which is why sufficient consumption is essential for their financial performance.

There is very little comparative data regarding consumer satisfaction and habits in small towns in Vietnam. However, some comparisons can be made by following progress in basic WSPST indicators with data from earlier years.

During the last phase of the program, customer satisfaction with water supply services in towns put into operation before phase III (November 2013) rose from 74% to 90%. 20 out of twenty one water supply schemes that have submitted data on their customer service development now have effective mechanisms in place (processing connections, billing, information on interruptions), whereas in the beginning of phase III there were no schemes with fully functioning customer service systems (WSPST, 2014).

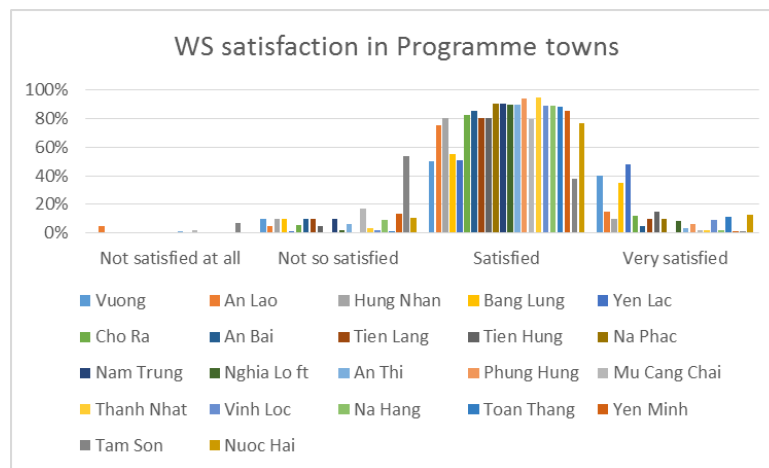

Figure 3: Satisfaction rate

Collection rate is 100% (of billing) in all schemes. Thirteen out of sixteen water supply schemes that had completed trial operation in the last quarter of 2015 covered their O&M costs from revenues, compared with three schemes in beginning of phase III (WSPST, 2014).

Awareness of the operator has increased, and 88% of customer survey respondents know who the operator is and how to contact them. 83% percent of customers say they have received a prompt and polite response after contacting the operator, and bill collectors have in many occasions been thanked for good customer service and professional attitude.

Social marketing has increased demand and acceptance of tap water; however, it could have been beneficial to engage sales agents of water supply related technology, eg. water meter sellers, kitchen sink sellers etc., as promoters.

#### Lessons learned:

Recruiting skilled individuals to key positions, who have strong feeling of responsibility and good professional motivation is clearly more important than the applied management model. Operators must have genuine interest and incentive in sound financial base and sales, ie. keeping customers happy.

## SUSTAINABLE SERVICES

### Professionalisation of Rural Water Service provision

Providing 24/7 safe water supply at the tap is still rarely considered a valuable target by scheme managers/operators, and they claim it increases power consumption and non-revenue water rate. Provincial water supply company directors claim they appreciate the 24/7 target, but mostly fail to demand it from their subordinates. In WSPST experience, 24/7 service certainly benefits the schemes. Even if it may slightly increase non-revenue water and power consumption in the short term, it will eventually help to ensure safety of tap water, reduce service pressure variation and leakages, improve customer satisfaction and willingness to pay.

Finally, proper plans and annual budgets for marketing the water supply service still lacking in many small towns and they are dependent on provincial parent companies to a great extent.

## Conclusions and Recommendations

Customers’ awareness on who the water supply scheme operators are, what their responsibilities are, and how to contact them is satisfyingly high. Social marketing approach has achieved its goal of improving both social and financial sustainability in WSPST program in Vietnam.

The approach is easy to replicate in other geographical and cultural contexts, as long as local partners are involved in the planning early on, and participate actively in implementing the approach.

Finding the right staff within service providers, who have both power and interest to try a new approach is challenging, but when successful very rewarding. A clear idea of what each staff member is responsible for and within their mandate to carry out in the beginning of implementation is necessary.

Engaging water equipment sales agents was not achieved in WSPST, but is recommended to ensure more local promotion on behalf of businesses.

Customer consultation and results obtained by it have proved not only to be a good motivator for staff, but have given small town water supply companies valuable insight into the expectations of their customers. This has not only created a better and closer relationship between the customers and operators, but also increased interest and connection rates to the services. It is highly recommended to train the local partners to engage in customer consultation from early on.

## References

- [International Development Enterprises \(year unavailable\) ‘Water Supply’](http://ide-vietnam.org/default.asp?sel=three&OneID=4&TwoID=6&ThreeID=16). Available at: <http://ide-vietnam.org/default.asp?sel=three&OneID=4&TwoID=6&ThreeID=16> [Accessed: 5 April 2016].
- [United Nations Human Settlements Program \(UN-HABITAT\) ‘Sanitation Marketing’](http://www.sanitationmarketing.com). Available at: <http://www.sanitationmarketing.com> [Accessed: 15 August 2016].
- [Water and Sanitation Program, \(2002\) ‘Selling Sanitation in Vietnam - What Works?’](http://www.sanitationmarketing.com/literature/162892/Selling_sanitation_in_Vietnam_-_What_works). Available at: [http://www.sanitationmarketing.com/literature/162892/Selling sanitation in Vietnam - What works](http://www.sanitationmarketing.com/literature/162892/Selling_sanitation_in_Vietnam_-_What_works), WSP - EAP, 2002. [Accessed: 5 April 2016].
- [World Health Organization et al., \(2011\) ‘Vietnam Water and Sanitation Sector Assessment Report’](http://www.wpro.who.int/vietnam/topics/water_sanitation/watsan_sector_report_vietnam_2011.pdf). Available at: [http://www.wpro.who.int/vietnam/topics/water sanitation/watsan sector report vietnam 2011.pdf](http://www.wpro.who.int/vietnam/topics/water_sanitation/watsan_sector_report_vietnam_2011.pdf) [Accessed: 5 April 2016].
- WSPST, (2013) ‘*Program Document for Phase III*’.
- WSPST, (2014) ‘*Inception Report*’.
- WSPST, (2016) ‘*Quarterly Report Q2/2016*’.

SUSTAINABLE SERVICES

Professionalisation of Rural Water Service provision

## Professionalizing Drinking Water Service Delivery in Small Towns of Haiti

Type: Short Paper

**Authors:** *Jean-Martin Brault<sup>1</sup>, Michael Merisier<sup>2</sup> and Carl Christian Jacobsen<sup>1</sup>, <sup>1</sup>The World Bank, <sup>2</sup>DINEPA, Haiti*

### Abstract/Summary

The EPAR (Rural Water Supply and Sanitation) Project of the National Directorate of Drinking Water and Sanitation [Direction Nationale de l’Eau Potable et de l’Assainissement DINEPA] played a leading role in the reform of the water and sanitation sector in Haiti. The Project, which ran from August 2007 to November 2013, supported the construction or rehabilitation of drinking water schemes in small towns with fewer than 10,000 inhabitants in the Sud region.<sup>65</sup> The Project significantly increased access to and improved the sustainability of water services in beneficiary communities by introducing a radical change in the way these services were provided. The Project’s results are all the more remarkable given that the EPAR was carried out in a period marked by political instability, devastating hurricanes, the 2010 earthquake and a cholera outbreak that is still ongoing.

### Introduction

Previous water supply investments in the Sud Region were limited and lacked monitoring from outside the communities.

As a consequence, water services deteriorated rapidly and communities became accustomed to receiving water free of charge. Against this backdrop, the Project adopted a management model that integrated domestic private sector participation and had been successfully implemented in Benin and Madagascar.

In parallel, Haiti began a reform process in 2009 that facilitated the continuous presence of DINEPA at the regional and local levels by creating OREPAs (Water and Sanitation Regional Offices), URDs (Rural Departmental Units) and TEPACs (Community Water and Sanitation Technicians). This paved the way for the development of a management model composed of: (i) a user association —the Potable Water Supply and Sanitation Committees [Comité d’Approvisionnement en Eau Potable et Assainissement CAEPA]; (ii) a professional water operator —the OP— contractually bound to the CAEPAs to operate the scheme and collect payments; and (iii) the URD, responsible for sustaining and supervising both the CAEPAs and the OPs.

### Description of the Case Study – Approach or technology

#### The local professional operator, a solution for increasing access to sustainable drinking water services

The EPAR Project was the first to integrate private water operators in rural areas of Haiti. A committee composed of representatives from DINEPA, technical assistance personnel from the Project and the relevant CAEPA selected the OPs based on pre-defined selection criteria, which included being a native of the town and being able to submit an operating business plan. The committee’s goal was to select an OP that would be accepted by the community and possessed entrepreneurial skills. Selected OPs received basic technical and managerial training.

The OPs work with half a dozen employees, including plumbers, secretaries, and kiosk vendors. They manage a customer base of 100 to 300 households with metered water connections (although a flat rate is

<sup>65</sup> Specifically, in the departments of Sud and Nippes (financed by the World Bank) and in the Grande-Anse region (financed by the Inter-American Development Bank).

## SUSTAINABLE SERVICES

### Professionalisation of Rural Water Service provision

charged in some cases) and a number of kiosks where payment is made per number of purchased bokit (19 liter container).

#### Main results and lessons learnt

##### Improved access to water...

The Project laid the necessary foundation for regular chlorination of the water. The results of SIS-KLOR monitoring (a real-time monitoring initiative whereby mobile water testing teams are able to send results to DINEPA via SMS) demonstrate that the OPs are regularly performing chlorination. Ongoing provision of free chlorine by DINEPA and monitoring by the URDs will help sustain this result over time.

In terms of access, the percentage of households connected to the water distribution system rose from 8 to 20 percent in beneficiary communities. This rate will increase further once new requests for connections are met: 65 percent of kiosk client households have indicated that they are willing to connect. In contrast, the average connection rate in small towns and rural areas of the country was 5 percent in 2011.

When kiosk users (21 percent of households) and those purchasing water from neighbors with a household connection (10 percent) are added to the number of beneficiaries connected to the water distribution system, the total population that gained access to safe drinking water through a network managed by a professional operator as a result of this Project is 50,000.

The Project also provided access to water to an additional 10,000 people living in communities where the water distribution system was not managed by an OP. Approximately 51 percent of the households located in the targeted communities are enjoying access to safe drinking water as a result of the Project.

The kiosks were not used as frequently as originally anticipated. Management of these facilities proved challenging for the operators, who gradually abandoned them. Users, who were unwilling to pay for service, found an easy way to obtain water by forcing abandoned kiosks open. The operators did not have the means to discontinue this practice. Only 50 percent of the kiosks are being managed by the OPs, and it is estimated that 15 percent of the households are using the abandoned kiosks to obtain water.

##### ... through professional, local, and cost-effective management

The operators have limited accounting skills, engage primarily in cash transactions that are rarely recorded and sporadically generate financial statements that are of very poor quality and usually limited to a cash balance. Nevertheless, the reconstruction of operators' financial statements demonstrated that they are achieving results: with average sales volume of US\$23 per year per connected household or kiosk client and up to US\$30 for the most efficient OPs, operators' compensation is expected to account for 25 percent of receipts.

These resources are used primarily to cover staff costs (41 percent), which represent an area for potential savings. However, 8 percent of the costs relate to infrastructure work, a significant improvement relative to the pre-Project situation when the CAEPAs conducted almost no maintenance work. Although these works most often entailed repairs and no actual maintenance program is in place, the operators have the potential to become proactive in infrastructure management.

The operators have also demonstrated their capacity to provide new household connections and further increase access to water services. However, this materialized as a result of the free provision of meters under the Project. The price of water meters in Haiti is above US\$100, and the OPs only have three years to recover their investments. This combined with the lack of support the OPs receive from the CAEPAs and the URDs to reduce delinquency rates prevents OPs from increasing their client base. DINEPA needs to propose a long-term solution, such as extending the duration of the management contract and/or leasing equipment or subsidizing procurement, to overcome this barrier.

## SUSTAINABLE SERVICES

### Professionalisation of Rural Water Service provision

Nonetheless, the results of the evaluation show reason to believe in the potential of the OP management model. OPs have been able to cover their operating costs, generate profit and finance corrective maintenance investments for approximately three years while increasing access to safe water. Moreover, field surveys show that users in the towns that piloted this solution are very satisfied with their service. Users overwhelmingly support the model and have a high level of confidence in the quality of the water.

### Challenges in achieving sustainability

Access to water services through individual household connections was expanded through the widespread installation of meters to facilitate volumetric billing. However, volume-based payment schemes could not be applied across the board. Rehabilitated schemes posed the first challenge; former users refused to have meters installed and prevailed upon the CAEPAs and other users to join their cause. As a result, the users served by some water schemes are not being billed based on volume of water used despite their general agreement about the benefits of volumetric billing in terms of fairness and ability to reduce water waste.

In comparison, in light of the infrequent use of the kiosks and the low revenue collection levels for services provided via individual household connections, the practice of reselling water to neighbors should be reexamined. Some 37 percent of households with a connection sell water to their neighbors, and the prices are similar to the ones charged for use of the kiosks. This practice, which had not been formally included in the Project, provides 10 percent of households in targeted communities with access to potable water.

The average revenue collection rate for OPs is 50 percent and reaches 66 percent in the best of cases. This rate is still too low to ensure that water management can suffice as the operators’ sole source of income. Nevertheless, the rate is enough for the OPs to make some profit thanks to the provision of free inputs such as chlorine and the initial batch of meters.

The success or failure of the OPs is largely dependent on the CAEPAs. CAEPAs often side with users against the professional operators, in particular with respect to the rejection of a payment system based on volume used, cases of illegal connections and even issues unrelated to the service. The CAEPAs see themselves more as a user association responsible for defending interests of the OPs’ clients than as the organization responsible for the provision of sustainable and safe water distribution services through a delegation agreement with an OP.

The operators need further support from the authorities in the areas of training and regulation. URDs should provide specific training to the professional operators on technical and management aspects and act as an independent mediation agent between the CAEPAs and the OPs. However, the URDs were unable to assume their role as regulators in contentious cases. The appropriate roles of these three stakeholders still needs to be adjusted and their relations better formalized. In one case, a CAEPA stripped one of the professional operators of his functions without the URD’s knowledge.

### Conclusions and Recommendations

The “OP model” can be considered a success even though further analysis is needed to assess its sustainability and prove that operators can provide service in challenging environments. The Public-Private Infrastructure Advisory Facility multi-donor trust fund is financing an evaluation of this model with the objective of defining the conditions and training needs required for this model to be scaled up and reach other regions of Haiti. This analysis and scaling-up of the model are at the heart of the recently approved World Bank-financed Small Town Water and Sanitation Project. The following lessons and findings highlight what needs to be improved in order for the OP model to provide sustainable water services to the small towns of Haiti:

- The operators do not yet have sufficient contractual security to allow them to engage in long-term planning in terms of business activities or infrastructure maintenance.
- Although users support the OP model, operators expend a lot of energy negotiating with users to obtain payment for connections or usage and managing local political interference.

## **SUSTAINABLE SERVICES**

### **Professionalisation of Rural Water Service provision**

- Increasing the number of kiosks was not the appropriate solution for increasing access; however, the practice of reselling water to neighbors has the potential to achieve the same objectives.
- While the recruitment process paved the way for the introduction of operators who were viewed as legitimate by the users, it did not attract candidates with the requisite financial and management skills.
- The conflicts that arose on the ground between the OPs and the CAEPAs could not be resolved through the intervention of the URDs, which lack the resources and an adequate regulatory structure to allow them to fully assume their role as regulators. The roles of these three stakeholders needs to be adjusted and formalized.
- A long-term solution must be implemented to make meters more affordable for the operators.

### **References**

All of the material from this submission is taken from Jean-Martin Brault, Zael Sanz and Bruno Le Bansais (2015) Professionalizing Drinking Water Service Delivery in Small Towns of Haiti; Lessons from the Rural Water Supply and Sanitation Project in the Sud Region (EPAR-Sud). World Bank: Washington, DC.

## SUSTAINABLE SERVICES

### Professionalisation of Rural Water Service provision

---

# Regional water supply to ensure basic services in rural areas of South Africa – what is required, what works, what are the challenges?

---

Type: Short Paper (up to 2,000 words)

**Author** *Monja Esterhuizen, Development Planner, UWP Consulting (Pty) Ltd. [monjae@uwp.co.za](mailto:monjae@uwp.co.za).  
Tel: +27 (0) 12 424 9709*

## Abstract/Summary

Access to basic (at least 200m from homestead) water supply is still a challenge in rural and developing areas of South Africa. A study was commissioned to investigate the backlog in supplying water to all areas of the KwaZulu-Natal Province. The study aimed to determine the current levels of water services, the consumers' current (2015) and future (2035) water requirements (based on demographics, growth and progressively higher service levels) and how both could be met if not provided for already according to national standards. Available water sources and other factors were taken into account to determine conceptual (potential) supply areas. Spatial and geographic analysis played an important role in the visualisation of supply areas, the conceptual planning of water supply infrastructure, in determining inputs for high level costing, and for estimating a timeframe for programme implementation. The results of the study are proposed water supply scheme areas that ensure access to basic supply to all consumers. The potential costs and timeframes for implementation are presented to assist the responsible authority in financial planning and phasing of projects.

## Introduction

South Africa has made tremendous strides in ensuring access to basic water, sanitation, and electricity services to all its citizens--currently estimated as 54 million people living in 15 million households. There remains, however, a small portion of the population, less than 10%, that require access to safe, reliable and adequate water supply – defined as the backlog. Households falling in the backlog category reside in rural areas, in dispersed villages and households. Road access to these areas is difficult and the topography poses an even greater challenge in planning and construction of affordable and appropriate services. Furthermore, the situation is exacerbated due to the limited and accessible water resources available in South Africa and the low economic status of unserved areas.

This paper aims to assist in conceptualising planning approaches to ensure water supply to communities and households in deep rural areas, considering 1) information required compared to what is currently available, 2) the methodology to determine water requirements and 3) developing scheme areas suitable for these consumers.

## Context

The study area (**Figure 1**) comprises of the uThukela District Municipality (UDM) in the KwaZulu-Natal (KZN) Province of South Africa. The municipality is designated as a Water Services Authority (WSA) and therefore responsible for water and sanitation services for its area of jurisdiction. From the 2011 Census the UDM had a total population of 668 847 people and 147 217 households. It covers an area of 11 326km<sup>2</sup> (similar to Abidjan and Tiassale combined) and is divided administratively into five Local Municipalities (LM) namely Emnambithi/Ladysmith, Imbabazane, Indaka; Okhahlamba and Umtshezi.



## SUSTAINABLE SERVICES

### Professionalisation of Rural Water Service provision

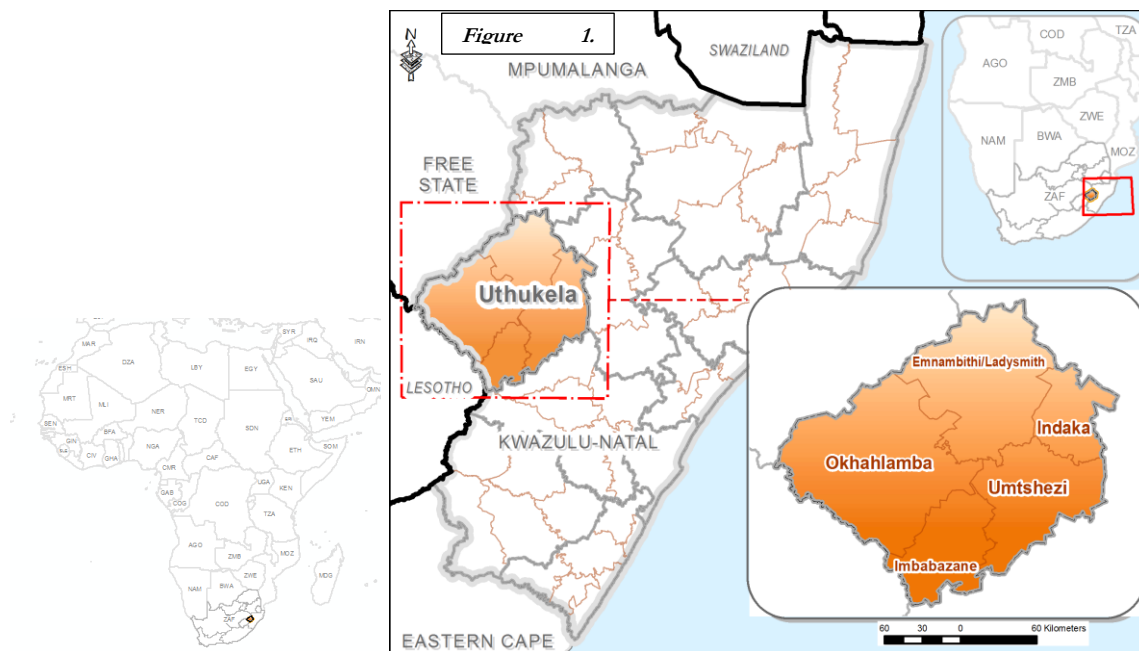

Figure 1: Study Area

The UDM is 38% urbanised (people living in urban and peri-urban areas), with the remainder of households living in traditional, tribal or farm areas. There are three larger well-developed urban nodes (total households 54 621) where the predominant economic activities are industrial, business services and manufacturing. The smaller towns and rural areas rely on agriculture (commercial and communal), mining and tourism as main economic contributors. Only the households in urban areas are billed for municipal services, of which the rate of payment is only 55% (reducing the potential income for re-investment by the District in municipal infrastructure).

Water resources consist of the Thukela River with its major tributaries: Little Thukela, Klip, Sundays and Bushmans Rivers. The main dams applicable to the UDM are the Woodstock Dam, Spioenkop Dam, Wagendrift Dam and the Driel Dam. Rivers drain towards the east coast of the KZN Province and discharge into the Indian Ocean.

According to the Uthukela Water Management Area Internal Strategic Perspective, surplus water is available downstream of the Driel Dam – at the Spioenkop Dam and downstream thereof, from the Thukela River. Surplus water is also available from the sub-catchment of the Bushmans River. The Little Thukela and Sundays sub-catchments however are already stressed in terms of water allocations. In the case of the Little Thukela, only water for basic human needs can still be allocated for abstraction (DWAf, 2004).

Most water supply schemes utilise surface water as source, but there are also many consumers in rural areas reliant on groundwater sources as well as springs. Groundwater quality in the northern parts of the UDM is affected by the coal mining activities and coal deposits found in those areas.

The 2011 Census indicated that there were 46 668 households (31.8%) from a total of 146 621 households in the UDM having water services below basic<sup>66</sup> levels. Most of these households (12 439) reside in the Okhahlamba LM – a predominantly rural area.

<sup>66</sup> Basic levels of water supply service, as defined in the White Paper for Water Supply and Sanitation Policy (Department of Water Affairs and Forestry, 1994) are Distance: Water supply within 200 meters walking distance; Quantity: 25 litres per capita per day; Quality: Water of acceptable quality; Availability: Water available 98% of the time and Flow/Assurance: Sustainable flow of 10 litres per minute.

## SUSTAINABLE SERVICES

### Professionalisation of Rural Water Service provision

The 2020 water requirements per LM are presented in **Figure 2**. Water requirements were calculated based on existing service levels and projected, progressively higher levels of service and considering population growth.

The Emnambithi / Ladysmith LM has the largest water requirements, requiring 46.1% (22.794 million m<sup>3</sup>/a) of all water due to urban and industrial development.

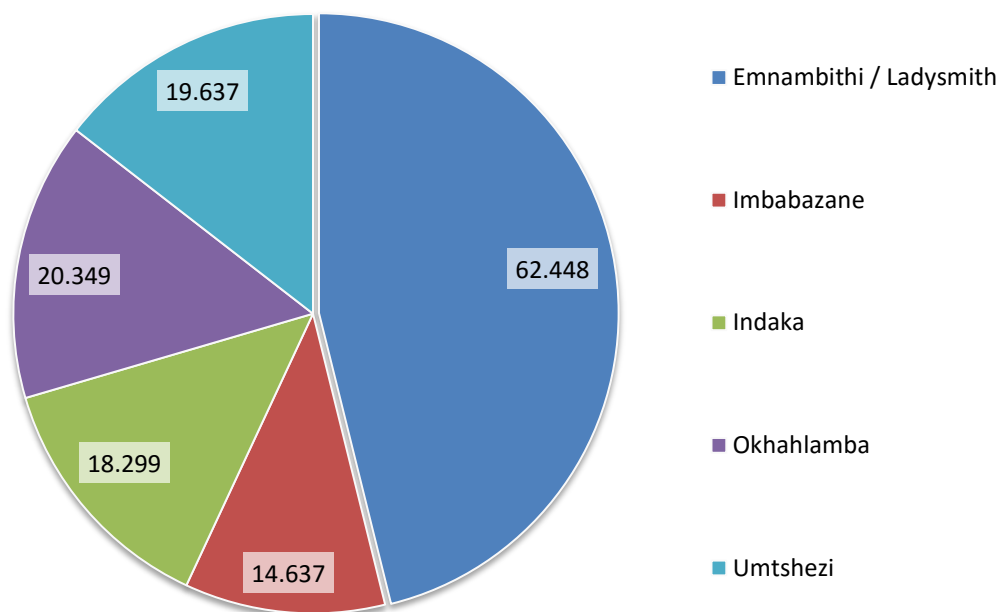

Figure 2. UDM 2020 Water Requirements (Ml/d)

### Aims

The aim of this study was to inform decision-makers on the current situation of water services and the required potential infrastructure and associated costs to address the backlog and to provide for water supply up to 2035. It included conceptualising new water supply schemes or propose upgrading or augmentation of existing water supply infrastructure.

Consideration was given to existing schemes, projects that are being implemented, available water resources, the institutional arrangements of the UDM and financial resources.

### Activities Undertaken

The first step (Status Quo) was to collect information on the **current water supply services infrastructure** (bulk and reticulation; supply areas) and confirm **water service levels** (ranging from house connections, yard connections, community stand pipes, to no formal service) and water sources in the UDM. The Department of Water and Sanitation (DWS) has an existing geodatabase with information on settlement areas and water supply infrastructure. Where possible, this information was updated from as-built drawings and input from municipal officials so that a Geographic Information System (**GIS**) could be utilised for spatial planning and mapping of the study area. Very little information was available in the form of as-builts of pre-2015 constructed infrastructure – whether as electronic or paper drawings – that could be verified against already-captured features in the GIS (this was mostly due to changes in institutional arrangements and relocation of electronic and paper media, getting lost in the process).

Parallel to the Status Quo investigation, a **water requirements model** was developed utilising 2011 Census population and supporting information (e.g., service levels, income, urban / rural character).

## SUSTAINABLE SERVICES

### Professionalisation of Rural Water Service provision

Population growth rates were established and following an approach to provide progressively higher levels of service, the water requirements for 2011, 2015, 2020, 2025, 2030 and 2035 were calculated. Provision was made for acceptable water losses, water conservation and water demand management (WC/WDM), current water consumption and settlement character (well-developed urban node versus rural settlement).

Various local and regional study reports were consulted to gain an understanding of the current and potential **water sources** available – for allocation for domestic consumption. A large component of existing water sources (114 million m<sup>3</sup>/a) utilised in the UDM – falling in the Upper Thukela Water Catchment, is for irrigation (87 million m<sup>3</sup>/a) with urban use in the main centres being an estimated 17 million m<sup>3</sup>/a. The other water catchments applicable to the UDM are the Little Thukela, Bushmans and Sundays River areas.

Groundwater is utilised in many of the rural settlements for water supply, but since almost no metering takes place, the quantities supplied is very difficult to determine. This summer's (2015/2016) drought resulted in a number of boreholes running dry, compelling the UDM to drill and develop additional boreholes or to provide water in the form of water tankers (the latter being a very expensive option).

Analysing the information, proposed supply areas were developed for consumers not yet supplied with basic services, taking into consideration the existing water supply infrastructure, available water sources, water requirements and further factors such as topography, township layout and institutional arrangements for water supply. These proposed supply areas were developed for settlements and not for individual farmsteads and their farmworkers as the farm owner is responsible for services (i.e. self-supply). The proposed supply areas were ring-fenced and initial sketches were made to represent the potential proposed infrastructure components (bulk pipes and components and reticulation pipes). The GIS was also used to estimate the number of community stand pipes to provide for and ensure they are within 200m of households.

Using the information captured in the GIS and cost parameters provided based on constructed infrastructure, preliminary costs were calculated for the proposed scheme areas. The costs included professional fees, costs for surveys, environmental investigations and stakeholder engagements.

The result was a report documenting how to reach universal coverage of all towns and settlements' water supply to fulfil current and future water requirements, taking available water sources, water service levels and costing into account.

### Main results and challenges

The UDM was demarcated into 34 water supply schemes (WSS) of which 21 were existing supply areas. Therefore, there were 13 future WSS areas proposed to ensure universal access of at least basic water supply to all (**Figure 3**).

The costs (all inclusive of construction, environmental, studies and fees) for implementation of the proposed schemes ranged from R28 162 (USD 1 976) per household, up to R256 316 (USD 17 987) per household and totalling R2 052 million (USD 144 million) for the UDM. The two largest future scheme areas would cost R564.2 million (USD 39.6 million) and R985.3 million (USD 69.1 million) respectively. These costs however are indicative as standard cost parameters were applied for non-capital expenditure (site investigations, community consultations, contingencies) and further refinement will be beneficial. The estimated costs however provide a very good indication of the financial investment requirements for the District.

The spatial distribution of households (generally a low population density of 568 persons / km<sup>2</sup> or 139 households / km<sup>2</sup>), access to existing services and water sources, affordability (for the UDM and

## SUSTAINABLE SERVICES

### Professionalisation of Rural Water Service provision

consumer) all play a role in water services planning, especially ensuring access to water supply for the poor.

The main challenges encountered during the study were:

- Having access to accurate, up-to-date information with coverage of the full study area:
  - ▼ Demographic information for all populated areas;
  - ▼ spatial information to represent water supply infrastructure;
  - ▼ metered water supply to calibrate (and validate) water use volumes (and current and projected water requirements);
  - ▼ confirmation of existing and planned water service levels;
  - ▼ establishment of population growth rates; and
  - ▼ access to planning documents or water supply planning conducted on behalf of the UDM, by other appointed consultants. (Very little information could be obtained from the UDM itself, except for the confirmation of water service levels and estimates of volumes of water supplied, from scheme operators and managers).
- Agreeing on parameters for the water requirements model (water consumption categories or indicators – litres per capita per day – per water use type or settlement type; rate of service level upgrades); and
- To what level of detail planning should be conducted for this study (it was not a detailed feasibility-level study where in-depth investigations were conducted to compare options between water sources and infrastructure sizing and capacities).

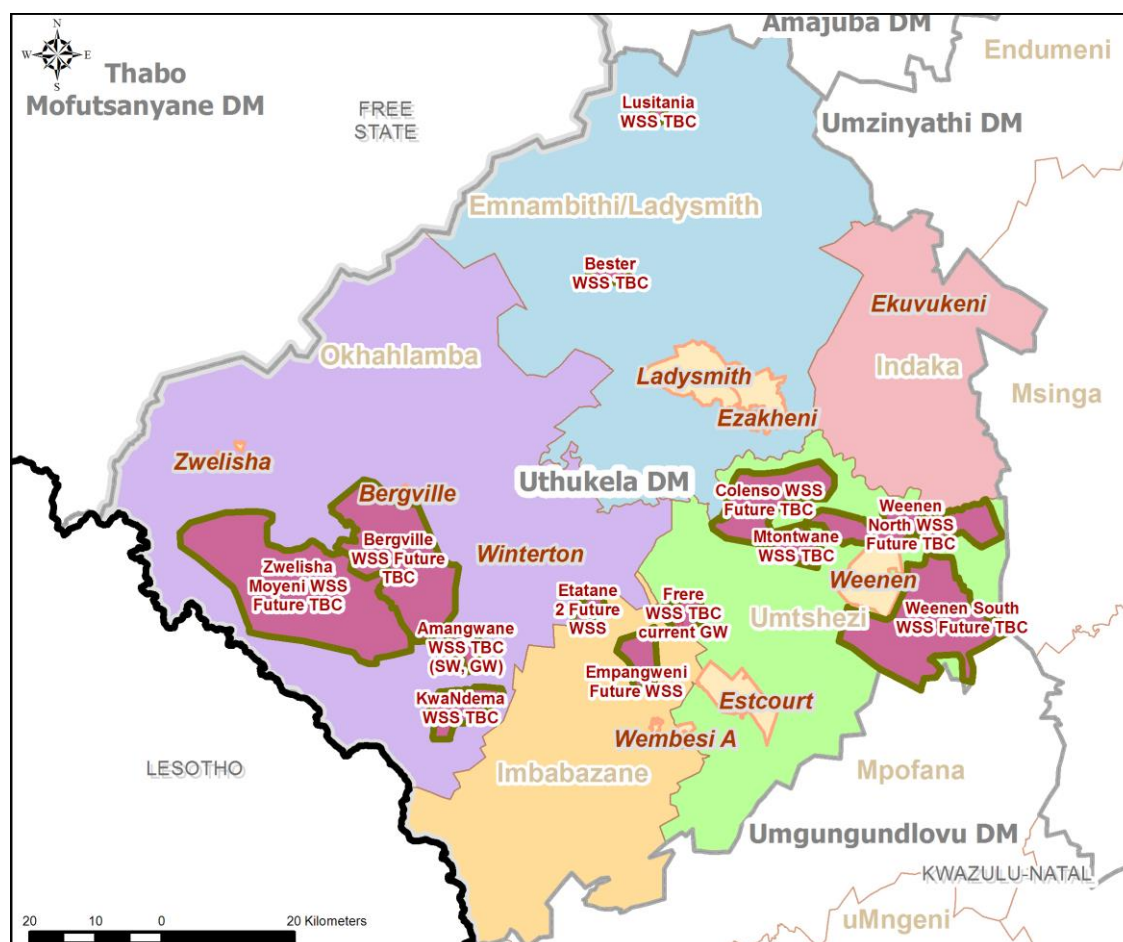

Figure 3. Proposed Water Supply Scheme Areas

## SUSTAINABLE SERVICES

### Professionalisation of Rural Water Service provision

#### Conclusions and Recommendations

There are thirteen areas in a water supply deficit or not having access to at least basic RDP standards of water supply and no existing project to fund new infrastructure. The water supply areas requiring development of regional bulk (>2Ml/d) services are:

- Bergville WSS Future (proposed supply area);
- Ekuvukeni Lime Hill WSS (existing supply area); and
- Zwelisha Moyeni WSS Future (proposed supply area).

It is recommended that detail feasibility studies be conducted for the above three areas to investigate options regarding the water source (existing and development thereof) and water supply infrastructure (cost versus service level and implementation programme). The costs for implementation as well as for operation and maintenance can then be determined within a high level of confidence.

If the planning commences in July 2016, these schemes could potentially only be commissioned during 2022 – 2023.

Detail feasibility studies can be used to develop Implementation Ready Reports that are required to meet funding application criteria (as managed by the Department of Water & Sanitation).

Smaller areas (<2Ml/d requirement) can likely be served through the development of local sources (most often groundwater schemes supplied from boreholes. There are eight such potential cases in the UDM).

#### Lessons learnt, what works and what is required:

- It is critical to have access to uniform (such as a national census) **primary datasets** to represent **demographics / households, water service levels** and settlement type (urban / rural character). If possible, such datasets should include existing water supply areas and **infrastructure** components (bulk and reticulation footprint, sizing and capacities where possible) as well as **water resources** (spatial features).
- Develop a study-specific **GIS** to spatially capture, query, analyse and represent information not only for the visualisation and planning of future scheme areas, but also in **discussion with officials** from the UDM (**developing media to facilitate discussions in the form of maps, data tables, and presentations**).
- The DWS, as custodian of South Africa’s water resources, has conducted several **water resource studies** – these were also vital in **reconciling water requirements, with available water sources** to propose new scheme developments. In South Africa, a process is under way to license all water use (except for abstractions for individual household use) by all sectors. This is to assist in determining the water balance for our resources and the volume of water that should be reserved for the environment and basic human needs, the volume of water in use and the volume of water that can still be allocated to new water users.
- To agree on a set of **design parameters** – guided by policy and engineering principles where possible – to determine current and future water requirements.
- Make use of **standard costing parameters** (for infrastructure components such as bulk pipelines, concrete reservoirs, etc.) to estimate the proposed schemes’ development costs (ideally calculated from recently constructed infrastructure).
- **Stakeholder input** plays an important role during the planning process – to **obtain information, verify** existing services and in discussion of the study results. This fosters **acceptance of the study outcome and recommendations for implementation** by the UDM. It further assists the UDM to evaluate options for funding of infrastructure (management, operation, maintenance, upgrading and new) and consider affordability for the service provider or implementer (in this case the UDM) and consumer (consideration to be given to the poor and the overall consumer profile of the service provider – how much can be invested and how much can be expected financially in return).

## SUSTAINABLE SERVICES

### Professionalisation of Rural Water Service provision

#### Acknowledgements

*Department of Water and Sanitation, KwaZulu-Natal Regional Office, Department of Cooperative Governance and Traditional Affairs, KwaZulu-Natal Province, Umgeni Water, uThukela District Municipality Officials, Ziyanda Consulting*

#### References

- Department of Water Affairs and Forestry. 2004. Internal Strategic Perspective: Thukela Water Management Area: Prepared by Tlou & Matji (Pty) Ltd, WRP (Pty) Ltd, and DMM cc on behalf of the Directorate: National Water Resource Planning (East). DWAF Report No. P WMA 07/000/00/0304.
- Department of Water and Sanitation (2011). Development of a Reconciliation Strategy for all towns in the Eastern Region: Amajuba District Municipality. First Stage Reconciliation Strategy for Newcastle Water Supply Scheme Area – Newcastle Local Municipality.
- Department of Water and Sanitation (2011). Development of a Reconciliation Strategy for all towns in the Eastern Region: Gert Sibande District Municipality. First Order Reconciliation Strategy for Greater Volksrust Water Supply Scheme Area – Pixley Ka Seme Local Municipality.
- Department of Water and Sanitation (2011). Development of a Reconciliation Strategy for all towns in the Eastern Region: uMzinyathi District Municipality. First Stage Reconciliation Strategy for Dundee Glencoe Water Supply Scheme Area – eNdameni Local Municipality.
- Department of Water and Sanitation (2011). Development of a Reconciliation Strategy for all towns in the Eastern Region: uMzinyathi District Municipality. First Stage Reconciliation Strategy for Glencoe Water Supply Scheme Area – eNdameni Local Municipality.
- Department of Water and Sanitation (2011). Development of a Reconciliation Strategy for all towns in the Eastern Region: uMzinyathi District Municipality. First Stage Reconciliation Strategy for Tugela Ferry Water Supply Scheme Area – Masinga Local Municipality.
- Department of Water and Sanitation (2011). Development of a Reconciliation Strategy for all towns in the Eastern Region: uThukela District Municipality. First Stage Reconciliation Strategy for Bergville Water Supply Scheme Area – Okhahlamba Local Municipality.
- Department of Water and Sanitation (2011). Development of a Reconciliation Strategy for all towns in the Eastern Region: uThukela District Municipality. First Stage Reconciliation Strategy for Colenso Water Supply Scheme Area – eMnambithi / Ladysmith Local Municipality.
- Department of Water and Sanitation (2011). Development of a Reconciliation Strategy for all towns in the Eastern Region: uThukela District Municipality. First Stage Reconciliation Strategy for Ekuvukeni Water Supply Scheme Area – Indaka Local Municipality.
- Department of Water and Sanitation (2011). Development of a Reconciliation Strategy for all towns in the Eastern Region: uThukela District Municipality. First Stage Reconciliation Strategy for Estcourt Water Supply Scheme Area – uMtshezi Local Municipality.
- Department of Water and Sanitation (2011). Development of a Reconciliation Strategy for all towns in the Eastern Region: uThukela District Municipality. First Stage Reconciliation Strategy for Ezakheni Water Supply Scheme Area – eMnambithi / Ladysmith Local Municipality.
- Department of Water and Sanitation (2011). Development of a Reconciliation Strategy for all towns in the Eastern Region: uThukela District Municipality. First Stage Reconciliation Strategy for Ladysmith Water Supply Scheme Area – eMnambithi / Ladysmith Local Municipality.
- Department of Water and Sanitation (2011). Development of a Reconciliation Strategy for all towns in the Eastern Region: uThukela District Municipality. First Stage Reconciliation Strategy for Loskop Water Supply Scheme Area – Imbabazane Local Municipality.
- Department of Water and Sanitation (2011). Development of a Reconciliation Strategy for all towns in the Eastern Region: uThukela District Municipality. First Stage Reconciliation Strategy for Weenen Water Supply Scheme Area – uMtshezi Local Municipality.
- Department of Water and Sanitation (2011). Development of a Reconciliation Strategy for all towns in the Eastern Region: uThukela District Municipality. First Stage Reconciliation Strategy for Winterton Water Supply Scheme Area – Okhahlamba Local Municipality.
- Department of Water and Sanitation (2011). Development of a Reconciliation Strategy for all towns in the Eastern Region: uThukela District Municipality. First Stage Reconciliation Strategy for Zwelisha Moyeni Water Supply Scheme Area – Okhahlamba Local Municipality.
- Department of Water and Sanitation (2011). Development of a Reconciliation Strategy for all towns in the Eastern Region: uThukela District Municipality. First Stage Reconciliation Strategy for Ezakheni Water Supply Scheme Area – eMnambithi / Ladysmith Local Municipality.
- Department of Water and Sanitation (2015). Reference Framework geodatabase. Directorate: Macro Planning and Information Management, Department of Water and Sanitation.
- Department of Water and Sanitation (2015). Quarterly Performance Evaluation Report of the Driefontein Complex Bulk Water Supply Project. KwaZulu-Natal Chief Directorate: Bulk Infrastructure Programme. RBIG KNR020. Period 01 July 2015 to 30 September 2015.
- IWR Water Resources (2015). Off-channel Dams in the Injasuthi River Catchment. Surface Water Assessment. October, 2015.
- Statistics South Africa (2013). 2011 Census Data Package (Small Area Layer level).
- Sukuma Consulting Engineers (Pty) Ltd (July, 2010). Uthukela District Municipality Bhekuzulu / Epangweni Community Water Supply Feasibility Study / Technical Report.
- uThukela District Municipality (2015). Geographic Information System (GIS) geodatabase and shapefiles.
- Uthukela Water (2003). Geographic Information System (GIS) shapefiles.
- UWP Consulting Engineers. (Pty) Ltd (March, 2015). Development and Implementation of Water Conservation / Water Demand Management in uThukela District Municipality. Bulk Water Meter Audit Report.
- Willcocks Reed & Kotze (June, 2006). Proposed Driefontein Complex Bulk Water Supply and Community Reticulation Project. Feasibility Report. March 2006. Amendment No. 1.

## SUSTAINABLE SERVICES

### Finance & Lifecycle Costing

#### 3.3.3 Finance & Lifecycle Costing

---

## Financing WaterCredit to enhance access to water and sanitation for attainment of SDGs

---

Type: Long Paper (up to 6,000 words)

#### Authors:

**Dr. Sanjay K Gupta**, Water Sanitation and Waste Management Specialist, Skat Consulting Ltd, Switzerland, [sanjay.gupta@skat.ch](mailto:sanjay.gupta@skat.ch)

**Prabhat Labh**, Program Manager – Financial Inclusion, The MasterCard Foundation, Canada, [plabh@mastercardfdn.org](mailto:plabh@mastercardfdn.org)

#### Abstract/Summary

WaterCredit is an innovative credit-driven model being promoted by Water.Org (WO) which enables Financial Institutions to offer loans to their clients for water and sanitation related products and services. WaterCredit was implemented by WO in partnership with 4 Financial Service Providers (FSP) in Kenya and 1 FSP in Uganda with US\$3.6 million funding from The MasterCard Foundation. This was the first WaterCredit initiative working with larger FSP partners in Africa implemented by WO. Over a five year period during Oct 2010 to Sep 2015, the program resulted in improved water and sanitation access for over 385,000 beneficiaries in Kenya and Uganda.

An independent evaluation of the WaterCredit program (Prime M2I Consulting, 2016) has brought some interesting findings that is worth considering for financing of Water Supply and Sanitation (WSS) services for people at the Base of the Pyramid (BOP) to reach sustainable development goals. Baseline study in different counties across Kenya established that access to water varied greatly, and as little as 15 percent household in some counties had access to piped water connection (ADREC, 2012) (Microsave, 2012), (Microsave, 2011) (Kipruto & Komen, 2012). A large majority accessed water from sources such as rivers, lakes, shallow wells, borewells, water vendors etc. Market research established the demand from un-served clients for access to finance for investing in household water and sanitation assets. Through WaterCredit, financial institutions leverage commercial capital to meet the WSS needs of the BOP, while leaving public and philanthropic funding to be strategically targeted at (i) measures that increase the availability of financing mechanisms for WSS for all (ii) serve those customers who cannot access or afford private financing due their economic or demographic status, and (iii) increase access to WSS while addressing other societal imperatives such as climate change and environmental conservation.

Access to financing for water assets eases a major bottleneck, and helps clients acquire the assets and access water. FSPs, particularly those focused on the low income segment, can play an important role in addressing the financing issues. However, traditionally, FSPs have prioritized their lending for income-generating purposes and perceive lending for consumption and other non-income generating assets as high risk. They lack the domain knowledge to develop customized products that cater to such demands which is traditionally considered as consumption.

The WaterCredit approach was effective in this context by bridging the gap between clients' needs and FSPs' ability to offer financial products and thereby eased the financial barrier in access to WSS. Institutionalizing the WaterCredit approach within the FSPs, which can secure commercial capital, will ensure sustainability of the approach. Increasing the loan amount and repayment period will further

## **SUSTAINABLE SERVICES**

### **Finance & Lifecycle Costing**

increase outreach to more and poorer clients. This greatly contributes to accelerating self-supply for those who cannot afford water services due to financial constraints. Key findings from a mid-term evaluation of the program in the year 2013 and an end-term evaluation in 2015 form the basis of this paper.

#### **Introduction**

While the MDG target of halving the proportion of population without access to improved water sources by 2015 was met, 748 million people or 10 percent of global population remains without access. Average investment over the period 2015 to 2030 to meet the SDG goals of universal access to basic water and adequate sanitation is estimated at \$ 49 billion (Traub, 2015), whereas current average annual overseas development assistance to the water and sanitation sector stands at approximately \$ 12.7 billion (OECD, 2014) which is far short of what is needed to solve this crisis. Today, there is a \$12 billion demand globally from families at the base of the economic pyramid (BOP) for access to finance to meet their water supply and sanitation (WSS) needs (Lebec, 2015). This is a huge potential market waiting to be discovered and, if targeted well, can result in substantial increase in access to WSS. Several FSPs and NGOs have developed financial products for servicing WSS related loans. Water.org is one such NGO which has developed a unique financing model, named ‘WaterCredit’. Through this approach, Water.org encourages Financial Service Providers (FSPs) to finance WSS. Smart subsidies are provided to FSPs to build their organizational capacity, identify communities’ needs through market research, develop appropriate financial products and generate awareness on WSS. These financial products can be availed by clients to obtain improved WSS solutions such as piped water connections, water storage facilities, wells, toilets, and rain water harvesting structures, often without much investment or intervention from the government. The WaterCredit project in Kenya and Uganda attracted a large number of women clients as they are the first to be impacted by WSS.

An independent evaluation of the WaterCredit program (Prime M2I Consulting, 2016) has brought some interesting findings that should be considered for financing of Water Supply and Sanitation (WSS) services for people at the Base of the Pyramid (BOP). Baseline study in different counties across Kenya established that access to water varied greatly, and as little as 15 percent household in some counties had access to piped water connection (ADREC, 2012) (Microsave, 2012), (Microsave, 2011) (Kipruto & Komen, 2012). A large majority accessed water from sources such as rivers, lakes, shallow wells, borewells, water vendors etc. Market research established the demand from un-served clients for access to finance for investing in household water and sanitation assets. Through WaterCredit, financial institutions leverage commercial capital to meet the WSS needs of the BOP, while leaving public and philanthropic funding to be strategically targeted at (i) measures that increase the availability of financing mechanisms for WSS for all (ii) serve those customers who cannot access or afford private financing due their economic or demographic status, and (iii) increase access to WSS, but while doing so, also address other societal imperatives such as climate change and environmental conservation.

#### **Context, aims and activities undertaken**

##### **Introduction to the WaterCredit approach**

Water.org has been working on water and sanitation issues in response to the water crisis faced by millions of people in the developing world. Water.org’s analysis revealed that a sizeable share of this global water crisis is faced by people in the Sub-Saharan Africa (SSA). In 2015, 663 million people worldwide lacked access to improved drinking water sources and almost half of these people (319 million) lived in Sub Saharan Africa (UNICEF and World Health Organization, 2015). While at the global level, the MDG goal on access to drinking water was met, four development regions including Sub Saharan Africa missed the MDG target for access to drinking water. From 1990 to 2015, the proportion of people having access to improved water sources in the region only increased from 48% to 68%. In other words, in 2015, one out of every three person in the region did not have access to improved water source. Progress on access to improved sanitation was even worse. The global MDG target for sanitation was missed by almost 700 million people. In the year 2015, only 30 percent households had access to improved sanitation in Sub



## SUSTAINABLE SERVICES

### Finance & Lifecycle Costing

Saharan Africa. The impacts of this crisis threaten development prospects in SSA and imperil the lives of millions of people. Each year, between 842,000 deaths in low and medium income countries are caused by inadequate WASH, out of which 502,000 can be attributed to unsafe and insufficient drinking water (World Health Organization, 2014) .

This slow progress in access to improved drinking water and sanitation can be attributed to the massive gap in the current development assistance and what is needed to meet the SDG goals. It was in this backdrop that Water.org developed a unique a market-based model, named ‘WaterCredit’, which can potentially contribute to solving the the water crisis the developing world is facing.

The WaterCredit model can be sustainable and scalable as it is market-driven and can attract growth capital. The model involves provision of credit by FSPs to individuals and households for WSS solutions – water connections, toilets, water tanks, rain water harvesting structures. Water.org supports the partner FSPs to scale the model over time by providing technical assistance and smart subsidies to develop a WSS product line for a new market segment, an area in which many FSPs lack technical expertise.

The WaterCredit approach was developed to create or enhance access to WSS by developing an alternative financing mechanism for WSS assets at the household level. This financing model encourages the FSPs to lend for investments in WASH related products and services. Originally, Water.org had also proposed to mitigate the credit risk perceived by FSPs by offering them credit enhancement in the form of gurantees. However, as Water.org gained experience with the approach, it realized that the FSPs could build substantial portfolio in WSS loans without credit enhancement. The model is built on the assumption that once the FSPs have the organizational capacity and appropriate WSS financial products and they work together with the product manufacturers and suppliers to put in place a viable supply chain, they will recognize the market opportunity in the segment and scale up the model. Moreover they will be able to leverage commercial capital to finance their WSS portfolio. Fig 1 below illustrates the interaction of various stakeholders in the WaterCredit model. It is worth highlighting that Watercredit is not just another credit or financial product. It is a comprehensive approach that brings together the physical product, the financial product, the supply chain and demand creation mechanisms in order to enhance access to water and sanitation services to excluded populations.

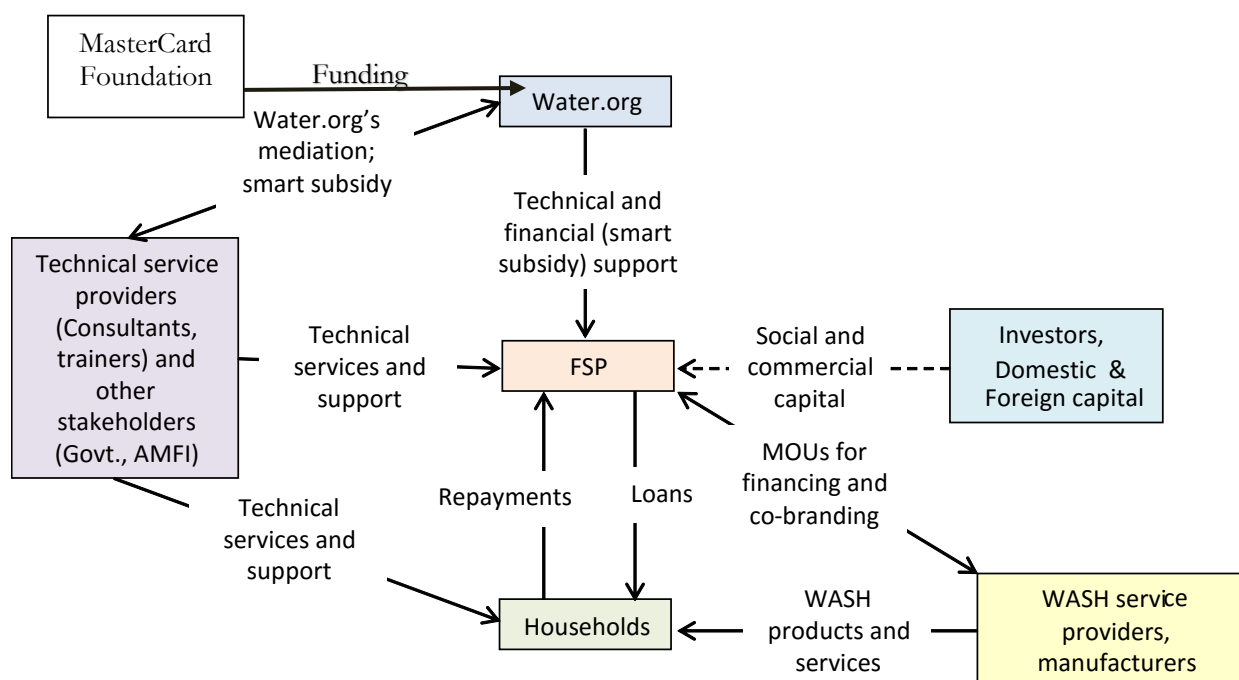

Figure 28: An overview of the WaterCredit Model

## SUSTAINABLE SERVICES

### Finance & Lifecycle Costing

Success of WaterCredit approach is conditional upon following factors:

- Aspirational, affordable and modular products and services which satisfy a need/demand
- Community/household demand for WSS financial products
- Presence of product manufacturers, suppliers, WSS service providers and a viable supply chain
- Presence of financial institutions and availability of capital for onlending for WASH assets
- Presence of support agencies to work on awareness and demand generatioin

### Role of key Partenrs:

**MasterCard Foundation:** The MasterCard Foundation provided funding to Water.org to test out the WaterCredit model in Kenya and Uganda. The total funding was \$ 3.6 million over a period of five years to present a develop a sustainable, market driven approach for access to water and sanitation.

**Water.org:** Water.org tested out the viability of the WaterCredit model across different financial service providerer institutions. Water.org played the critical role of FSP selection, market research, product development and providing the technical assistance to the FSPs. Beside these it also built capacity of the FSP staff to understand products and answer queries from customers on WSS.

**Financial Service Providers:** The FSPs partnered with Water.Org to test the financial products, partnered with tank and sanitation product suppliers to get door step supply and also created awareness among both new and old cleints on WSS.

**M2i:** M2i carried out the mid term and end evaluation of the project. The mid term evaluation came out with critical recommendations which helped in improving the product package and upscaling the program strategy.

### Is there unmet need and demand for WSS?

In the twenty five years since the joint monitoring program was put in place by the UNICEF and World Health Organization, significant progress was made in Kenya and Uganda in access to water, but extremely slow progress in access to improved sanitation as depicted in Fig 2. In Kenya, percentage of population lacking access to drinking water came down from 57% to 37% during 1990 to 2015, but it fell short of meeting the MDG target. Uganda was successful in meeting its MDG target in access to drinking water, bringing down the proportion of people lacking access from 60% to 21%. However, progress of both the countries in improving access to sanitation was quite slow, and they both failed to meet their MDG targets.

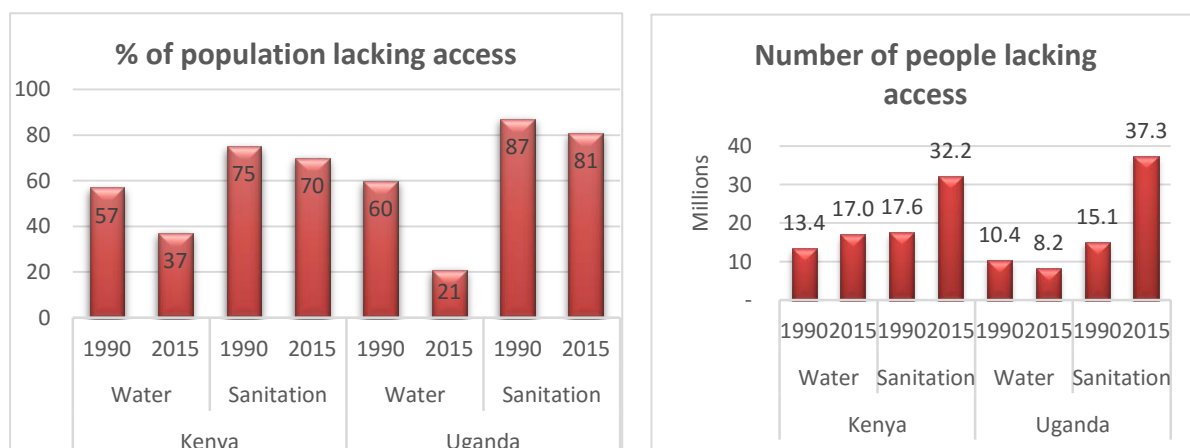

## SUSTAINABLE SERVICES

### Finance & Lifecycle Costing

**Figure 30: Percentage of people lacking access is** During the period 1990 to 2015, the population of Kenya increased by 96%, and that of Uganda increased by 125%. This meant that despite an increase in the percentage of population having access to water and sanitation, the absolute number of people not having access to clean water and sanitation also went up as can be seen in Fig 3. Increase in the number of people lacking access to improved sanitation is quite alarming.

**Figure 29: No of people lacking access has**

**Figure 31: Sources of water during rainy season in Kenya**

Water Source	% of households
Rain Water	39%
Piped Water-Piped to compound/plot	13%
Dug Well-Protected Well	11%
Water from Spring-Protected Spring	8%
Surface Water (river/dam/lake/pond/stream/canal/irrigation channel)	8%
Piped Water-Piped into dwelling	6%
Piped Water-Public Tap/Standpipe	5%
Tube Well or Borehole	3%
Dug Well-Unprotected Well	3%
Water from Spring-Unprotected Spring	3%
Tanker Truck	1%
Cart with Small Tank	1%

(Captiva Africa, 2014)

This clearly indicates a massive gap in access to clean water and the urgency with which these need to be prioritized. Coming to the community level, the evaluation found a number of constraints in accessing WSS:

### Water

- Need to fetch water from distant sources, including rivers, ponds and lakes. Water from many of these sources is not hygienic, and become particularly dirty during the rainy season.
- Women and children have to spend significant time fetching water which reduces their productive time.
- Those who cannot fetch water due to work engagements, long distance to the water source, disability, old age or sickness, have to buy water from vendors or hire labor to fetch water. Respondents had to spend \$1.00- \$1.50 per day to access water.
- Dirty water resulted in frequent stomach diseases such as amebiasis.
- Even in areas with a piped water connection, the supply is insufficient. Most people in Nairobi got water once every two or three days. In remote areas people often get water only once a week through the piped connection and the situation worsens in the summer.
- There are community managed boreholes, but people have to spend significant time in queue to get water from boreholes. In certain areas, the water from borehole was ‘salty’.
- Respondents reported that issues such as poor maintenance and frequent breakdown of pumps in boreholes often resulted in lack of water availability.
- Many people wanted to have water tanks but could not or did not want to become members of microfinance institutions. This group of people often persuaded existing members to take a loan

## SUSTAINABLE SERVICES

### Finance & Lifecycle Costing

on their behalf, arranging to pay the installment for making the repayments as per schedule.

As per official statistics 63% of the Kenyan population has access to improved water facilities, even those having these facilities do not get adequate water due to irregular and insufficient supply. Many people depend on water vendors and there is significant demand for storage products. **So, there is still a massive gap in access to regular and reliable supply.** Many wanted to supplement self-supply with that of sporadic or lack of daily municipal supply to get adequate water.

#### **How the WaterCredit project addressed these needs?**

The WaterCredit program was implemented by Water.org during Oct 2010 to Sep 2015 in Kenya and during Oct 2013 to Sept 2015 in Uganda. With funding from the MasterCard Foundation, Water.org identified four FSPs in Kenya and one FSP in Uganda and provided them technical assistance and smart subsidies to develop and roll out financial products to address the WSS needs. The FSPs were selected through a rigorous process of certification and comprised a mix of large commercial banks and large and medium sized microfinance institutions. Water.org helped the FSPs conduct market research and demand assessment studies and helped develop the product prototypes, which were then pilot tested in some of the branches. After running the pilot test for about six months, the products were rolled out across the entire branch network of the FSPs with necessary adaptations. To measure the project’s impact, a baseline and an endline impact study were conducted.

The project benefited over 385,000 people through improved access to water and sanitation through disbursement of over 77,000 loans by these FSPs to the clients for investing in water and sanitation products. The loan appraisal by the FSPs followed the standard process. However, instead of disbursing the loans to the customer, the loan amount was directly transferred to the water and sanitation solution provider selected by the client. The water and sanitation solution providers then delivered the product at the doorsteps of the clients. The FSPs monitored end-use of the financed products on a sample basis and often liaised with the product manufacturers and suppliers to ensure that the products were adapted to meet the demands of the customers. Loan repayment was typically made in monthly instalments over a period of 6 months to 24 months and was made directly to the FSPs by the clients. As many as 88 percent of the beneficiaries lived in rural areas. Average loan size advanced by the FSPs was \$572.

#### **Main results and lessons learnt**

##### **Relevance of the project in meeting the need**

The evaluation finds the **project approach to be relevant** for creating and improving access to clean and affordable water and sanitation services for low income clients. In the rural and peri-urban, availability of the WSS products is a big constraint. In the urban markets, while WSS products may be available, affordability is a key concern for both urban and rural customers. Unit cost of typical WSS products (water tanks, boreholes, improved toilet products) ranges between US\$ 250 to US\$ 3,000 which is a very large amount for low income families to accumulate and pay in one installment.

Access to financing for water and sanitation products through WaterCredit eases this bottleneck and helps clients acquire the products and access water. Financial institutions, particularly those focused on the low income segment can play an important role in addressing the financing issues. However, traditionally, microfinance institutions have prioritized their lending for income generating purposes and perceive lending for consumption and other non-income generating assets such as WSS infrastructure as high risk. FSPs lack the domain knowledge to develop financial products that cater to demands of WSS clients, who often seek information on cost of asset construction, installation, site, technical inputs, qualified masons, and product quality. FSPs lack such information and knowledge.

The WaterCredit approach was effective in this context by addressing the gap between clients’ needs and FSPs’ ability to offer required financial products and thereby easing the financial barrier for access to WSS access. Institutionalizing the WaterCredit approach within the FSPs who can attract commercial capital might ensure sustainability of the approach.

## SUSTAINABLE SERVICES

### Finance & Lifecycle Costing

#### Why people are accessing WSS financing?

Fig 4 below provides the purposes for which the clients accessed WSS financing. This included purchasing water tanks, securing piped water connection, constructing shallow wells, constructing toilets, buying material and accessories for rain water harvesting and installation of household water or sewer connection. Purchasing water tanks was by far the largest source of demand for WSS financing. What was interesting is that many clients who accessed a loan for buying a water tank, went for a repeat loan to buy a bigger second tank subsequently. This clearly establishes that people see value in accessing loan to buy a water tank, and that is why, over time, they go for a second loan to meet their unfulfilled need for water. This also has implication for design of financial product. Giving a smaller first loan reduces the risk to the borrower and the FSPs to test out the product and see if it benefits them before taking on the larger risk of taking a larger loan. Small size of initial loans allows one to buy only a small tank, and most customers go for a second loan after repaying the first to buy a bigger second tank.

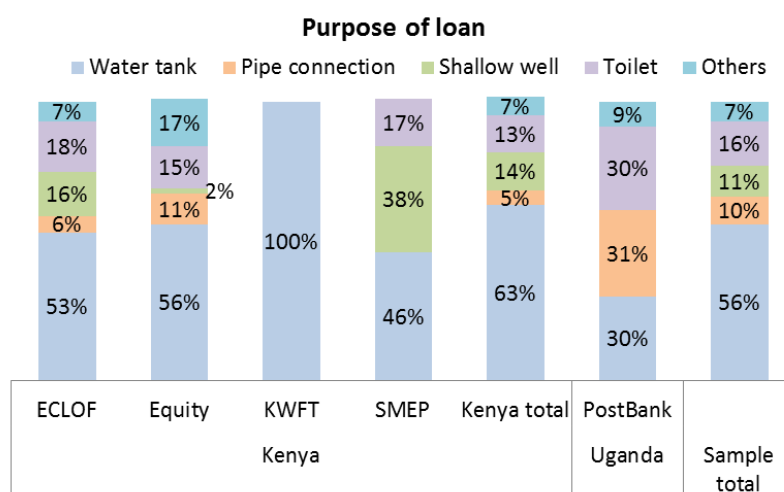

Figure 32: Sample distribution of loans by purpose

#### Outputs of the WaterCredit program in Kenya and Uganda

The table below shows the total number of different types of WSS loans disbursed during the five years of the project and the total amount disbursed through these loans. (The number of loans disbursed during the first two years was quite small, as the FSPs were in the process of product development and roll out.

Total Number of loans	77,230
Water loans	52,247
Sanitation loans	11,446
Water and sanitation loans	13,537
Average loan size(USD)	\$572
Number of FSPs involved in the program	5 (4 in Kenya and 1 in Uganda)
Percentage of women borrowers	55%
Total Number of beneficiaries	385,878
Percentage of rural beneficiaries	88%
Interest rate charged by the FSPs	16% to 22% flat rate <sup>1</sup>
Portfolio at risk for FSPs	2% to 4%

Figure 33: Key highlights of the WaterCredit program

SUSTAINABLE SERVICES

Finance & Lifecycle Costing

<sup>1</sup>This corresponds to an average effective interest rate of about 45% for the borrowers.

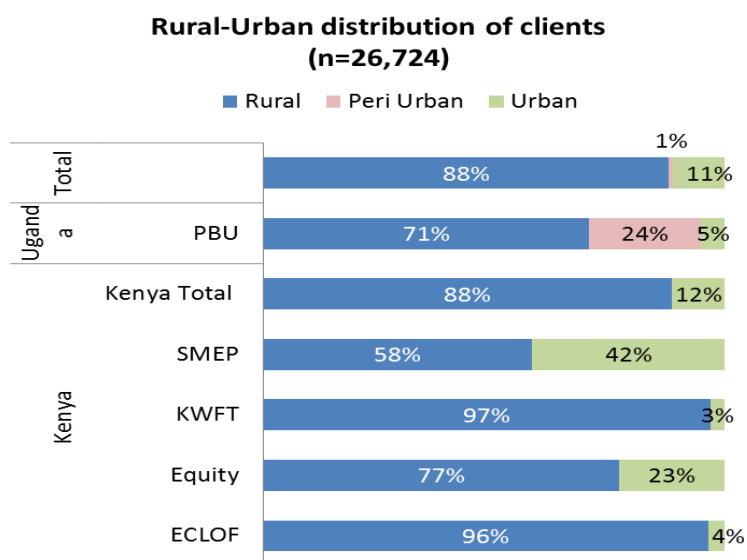

**Figure 34: Rural-urban distribution of beneficiaries**

The program benefitted a disproportionately large number of rural clients, where the gap in demand and supply for water and sanitation is much bigger. It is important to mention that many prospective clients who were not part of the groups could not access the loans. The Fig- 7 provides the distribution of loans distributed by different FSPs in the rural, peri urban and urban access. A very large majority of beneficiaries are from rural areas, where infrastructure to provide piped water connection and communal access is poor and self supply remains easier than any other option. Data confirms the core assumption behind the approach that WaterCredit approach will be effective in areas where public or communal access does not exist or is less than satisfactory.

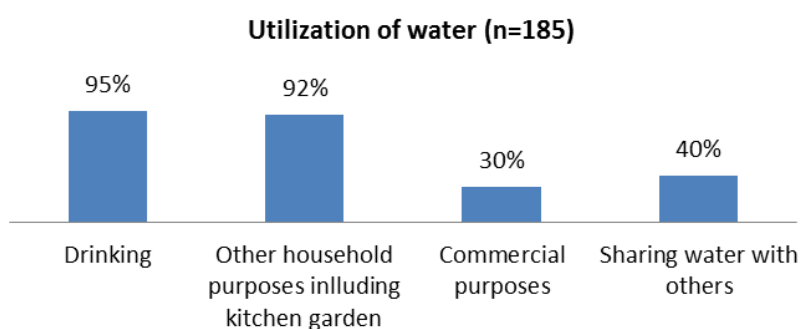

**Figure 35: Utilization of Water**

People are using the increased access to water for a variety of purposes and not just for drinking purposes, as evident in Fig 8. This project revealed that water financing for self-supply not only addresses the need for drinking water, in almost every case, it was also used for other household purposes, such as mushroom farm, kitchen garden or to support other small income generating activities. As many as 30% of the beneficiaries are also using it for commercial purposes, becoming water vendors and thereby earning an income. Two out of every five beneficiaries or 40% also share water with others such as neighbors. The evaluation found that the actual number of beneficiaries per loan (or multiplier effect) of the project was significantly higher (an average of seven beneficiaries per loan as against five assumed

## SUSTAINABLE SERVICES

### Finance & Lifecycle Costing

originally.) This was on account of the fact that the WaterCredit approach was designed primarily with households in mind. But when the program was rolled out, it also attracted a large number of institutional borrowers, such as schools, church etc where the number of beneficiary for each loan was much larger. Many schools borrowed loans to buy both water tanks and rain water harvesting structures.

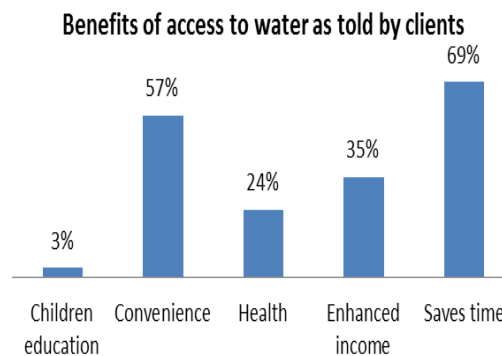

**Figure 36: Benefits of access to water**

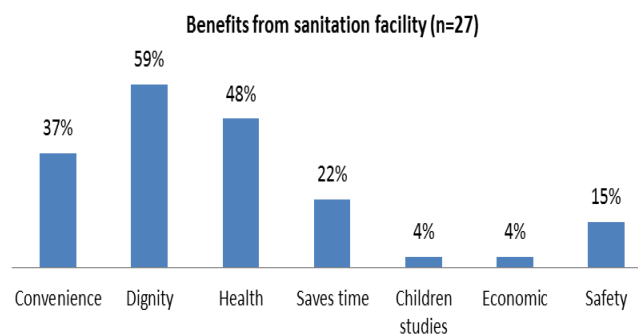

**Figure 37: Benefits of access to sanitation facilities**

Fig- 9 presents perceived benefits from access to water and sanitation. The amount of time saved and convenience in accessing water came in as two of the highest ranked benefits. Convenience captures several elements- no need to travel long distances, no need to carry heavy jerry cans, ability to access water when needed and where it is needed etc. As many as one in three respondents reported enhanced income as a benefit and one in four reported health benefits of access to clean water. In a small number of cases, the respondents also reported the positive impact on children’s education, since they no longer need to spend a significant amount of time fetching water and can devote that time on education.

User feedback on benefits of sanitation (Fig 10) were surprising, with improved dignity ranked as the biggest benefit by as many as 59% of the respondents. This points to a clear dichotomy between the perception of users and promoters of sanitation such as public health agencies, NGOs etc. Whereas for the users the dignity followed by health and convenience rank as the most important benefits, the promoters prioritize improved health outcomes as the key driver for sanitation programs.

Interaction with the water and sanitation clients brings out critical aspects for success of the schemes.

- Well thought out and packaged financing- adequate loan size, quick processing, reasonable repayment tenure aligned to household cashflow and affordability.
- Working on both financing of WSS products as well as WSS product supply and availability. E.g., Transportation cost of water tanks can be as much as the cost of a tank itself. Offering

## SUSTAINABLE SERVICES

### Finance & Lifecycle Costing

door-step delivery of tanks can thus significantly reduce the cost of ownership. The supplier can distribute the transportation cost across multiple buyers by using transportation planning tools.

- A coordinated approach between the financial institution providing financing, product manufacturers incorporating design elements in the products as per client preference, product suppliers working out the logistics and finally, organizations working on awareness on correct installation, product usage can ensure good take up.
- Because FSPs are the biggest customers for the water tank manufacturers, they are able to bargain for a volume discount on pricing, which reduces the effective cost for the borrower.





## SUSTAINABLE SERVICES

### Finance & Lifecycle Costing



In summary, the four P's of marketing- right product, delivered at the right place at the right price and right promotion are all key to success of WaterCredit.

The evaluators found that some FSPs finance the cost of water tank but not installation. As some clients are not able to cobble together additional funds needed for installation, the water tank that they buy may remain unused for a long time. On the other hand, they have to start repaying the loan the moment they borrow. This affects the borrower satisfaction, and also lack of effective usage of the asset. It was also observed that the average loan size given out by larger banks is significantly larger than smaller MFIs. Clearly, the water and sanitation products cost more, and FSPs with greater financial capability to lend for water and sanitation products will be more successful.

**WSS financing can be sustainable for FSPs if it is done at scale and if the product is priced right.**

Income	
Yield on portfolio (YOP)	42%
Other income	2%
<b>Total income – A</b>	<b>44%</b>
Expenses	
Loan loss cost	2%
Financial expenses	10%
Operating expenses	27%
Depreciation	1%
<b>Total expense ratio – B</b>	<b>40%</b>
<b>Margin (A-B)</b>	<b>4%</b>

Figure 38: Break-even analysis for WaterCredit Portfolio

The evaluation looked at the operating costs, yield on portfolio, pricing of WASH financing product for all the five FSPs. Analysis in Fig 11 is based on the average incomes and expenses from WASH portfolio of four of the FSPs in Kenya. In all these four cases, the WASH product is priced similar to other credit products of the financial institutions. Assuming that the cost of funds and operating expenses of the financial institution remains the same in the WASH portfolio as in their general portfolio, reaching breakeven is a function of building adequate scale to recoupe the product development cost and fixed costs particular to the WSS product. Average financial margin for the FSPs on WASH products is 4%.

Developing the WSS portfolio also required an upfront investment of about US\$ 200,000 per FSP in

## SUSTAINABLE SERVICES

### Finance & Lifecycle Costing

market research, product prototyping, making necessary adaptations in their management information system, staff training and development, and product roll out across their branch network. In addition, the financial institutions had a recurring cost of \$27,000 per year for managing the WSS portfolio over and above their routine operating expenses. If the fixed cost of product development is ignored, then the financial institution can reach breakeven at a volume of 2,700 loans or \$675,000 in outstanding WSS loan portfolio. However, if the product development costs, (assumed to be amortized over ten years) is included in the fixed cost, then the breakeven scale increases to 4,700 units or \$1,175,000 in outstanding wash loan portfolio.

Given the small size and relatively small balance sheets, most financial institutions do not have adequate capital to make this upfront investment in product development. Thus, even though there is demand for WSS products and WSS financing can be profitable, availability of capital for upfront investment in product development becomes a bottleneck. This is where the catalytic role of funding from government or donors such as MasterCard Foundation becomes critical. By funding the technical assistance and product development cost support to the five FSPs in Kenya and Uganda, the MasterCard Foundation helped Water.org test out the viability of the WaterCredit model across these different institutions. Water.org played the critical role of FSP selection, market research, product development and providing the technical assistance to the FSPs. Because the product development cost was taken out from the breakeven point calculation, as many as three out of four financial institutions in Kenya could reach close to or exceed the breakeven point. However, if the cost of amortizing the product development cost is included in the breakeven point calculation, then only two out of the four institutions- the larger financial institutions attain the breakeven point. For the smaller institutions, disproportionate concentration of exposure to any one sector is risky. So, they might continue to operate below breakeven point and may not attain sustainability.

**Product development cost is a fixed cost.** If it can be distributed/ amortized over a larger number of beneficiaries, then it can be sustainable. However, smaller institutions do not have the institutional financial capacity, management bandwidth and funding to go for scale in this product line. As a result, same amount of donor subsidy generates a much larger social return when deployed through a larger institution compared to smaller institutions. Since upfront product development costs can be significant, there is case for the government and donors to subsidize the product development cost, then financial institutions can take the product commercially to a large number of households.

The evaluation finds several cases where clients are going for repeat loans. While that may be a good indicator, a deeper examination reveals that they are going for repeat WSS loan, because the first loan was not adequate to buy a large enough water tank for their purpose. So, they first take a small first loan to buy a small tank (or just offered a small loan first) and then a bigger loan to buy a bigger tank. While for some clients, this incremental approach is less risky and more practical, other clients wanted to have the flexibility of access to larger loans to buy larger tanks. With high dependence on the water tank, a smaller tank does not provide adequate storage. This is where the financial capacity of the institution- to provide larger loan, flexibility in providing longer duration repayment for larger loans, risk management and liquidity management etc become crucial.

Four clear lessons emerge from this evaluation for structuring Water and Sanitation financing.

- (i) By smart deployment of subsidy, government and funders can get the financial institutions attracted to WSS financing in a sustainable, market driven manner. Deploying about \$3.6 million in donor funding resulted in enhancing access to water and sanitation for almost 385,000 people. The direct cost of enhancing access to WSS for each beneficiary comes at under \$ 10 for the donor funds. The cost of water tank itself is a loan from the FSP, which is repaid by the borrower in installments along with interest. \$ 3.6 million in donor funding cat-

## SUSTAINABLE SERVICES

### Finance & Lifecycle Costing

alyzed over \$20 million in private capital deployment towards water and sanitation. In other words, every philanthropic dollar leveraged over six dollars in commercial funds towards enhancing WSS access.

- (ii) With the right physical product and financial product availability, a lot of gaps in access to water and sanitation can be addressed by private capital.
- (iii) Being successful in this business requires financial institutions that can do this at scale, because at smaller scale, it will not be viable, and
- (iv) There are inherent limitations of the WaterCredit model. It can only work for people who can take and repay loan at market rates. It cannot serve the clients who cannot be reached by the financial institutions. In other words, WaterCredit model may not work with the clients who are considered high risk, or who are too far away from the bank branches. This is where new innovations will be needed. Water.org is exploring the use of digital technology and targeted subsidies to extend access to segments considered high risk by the financial institutions.

**Role of public funding (funders, government) : how public investment in product development can generate public good** rather than benefitting just a few companies. Market research and product development is a rigorous and expensive process. However, once this investment is made, then it can be used by several market players, not just one institution, provided there is a strong knowledge sharing and dissemination strategy. In a market systems development approach, there has to be a deliberate strategy for crowding in other market players, once a viable model has been tested by a few FSPs. While each institution needs to undergo its own product development process, at least there is some market research information that can make it less expensive and faster for the new entrants to get into the market.

### **Even a successful model cannot be replicated without taking into account unique context**

Deliberate strategies to facilitate learning for new institutions may reduce the cost of product development and time needed to roll out the product, as new institutions can learn from others. In Kenya, Water.org followed a rigorous market research and product development process across all four FSPs. Besides requiring a substantial investment, it also meant a significantly longer process before the products roll out. Learning from this, and using the tool kits that the Water.org team had developed in Kenya, their roll out strategy in Uganda was much faster. As a result, the timeline for product roll out in Uganda was cut down by more than half. However one must exercise caution in replication and scaling up, since a simple copy-paste solution may not work in a different context. In this case, while the expansion in Uganda was much faster, the FSP in Uganda did not do its homework right on the pricing model for the WaterCredit. As a result, their current product pricing is unviable and not sustainable. Due to limited market research, the FSP in Uganda could not anticipate strong demand from institutional clients resulting in much larger average loan sizes. So, on the one hand, their portfolio is not yielding positive financial margin. On the other, it has grown in size at a faster pace than anticipated due to larger than expected average loan size and composition of customer segments that is not limited to individuals and households. This will likely force the FSP to either slow down the roll out in order to cut their losses, or else, change the pricing to make it profitable.

### **What it means for FIs to have a WSS portfolio**

The evaluations from the two countries shows that WSS financial products have the potential to evolve and cater to larger market segment where apart from households even institutions, entrepreneurs, manufacturers, water boards etc. could also become potential clients. Financial Institutions already have experience financing such clients with good repayment. This means they will not just attract old clients but also new clients.

- Except for one, all financial institutions had similar pricing (interest rate, fees and payment) for WSS loans as charged for other regular products. There was no element of direct subsidy in WSS financ-

## SUSTAINABLE SERVICES

### Finance & Lifecycle Costing

ing.

- Financial Institutions report the operating expenses of the WSS portfolio at the same level as other products. However, there are some additional expenses related to monitoring particularly of toilets but then there is also some additional income in the form of commission for those FIs which have partnership with WSS product suppliers.
- The portfolio quality (measured by Portfolio at Risk Ratio - PAR) of WSS loans for all financial institutions is better than the overall portfolio quality of the institution.
- There is an increasing WSS loan disbursement trend that goes beyond targeted households segment like churches, schools and small businesses (hotels, food joints).

One of the key takeaways is that a rigorous financial analysis should be done to estimate break-even level for FSP at the beginning of the project itself. The analysis should guide the targets for the project in terms of number of disbursements and loan portfolio for FSPs. Ideally, it should be ensured that the WaterCredit portfolio reaches a financially sustainable scale within the project period of 3-5 years with donor support to the FSP. This particular WaterCredit program of Water.org shows the following results from the program evaluation:

- The WSS portfolio had not just helped in client retention but had also helped in new client acquisition. Organizations estimated that more than 20% WaterCredit clients are new.
- Across all institutions, most staff had received training on WSS. Financial institutions also had WSS champions to promote WSS awareness and outreach.
- All institutions had included WSS financing in their strategy, business plans as well as in budgets.
- Financial institutions were engaging with new partners like water purifier and water tank companies and developing partnership to smoothen product delivery.
- New departments and staff structures have been created for efficient delivery of WaterCredit.
- WSS loans were also included in staff performance appraisal.
- Flexibility in product design and adaptive capacity is needed
- Sufficient resources must be allocated to monitoring and evaluation and for follow up

From the facts, broadly it can be concluded that with a reasonable size of WSS portfolio there is a high likelihood for the WSS portfolio to be profitable. But it is important to understand that for executing a specialized product like WSS any FSP will need a team of people who can act as WSS champions or Managers to cover sensitization, promotion and leadership. They will help in technical capacity building, supplier management, efficient product delivery etc. The expenses pertaining to these staff are mostly fixed cost.

Another learning was that the way the product is structured within the organization also impacts its performance. Having a sponsor amongst the senior staff to champion the product within the organization ensures buy in and success. It was seen that organizations where credit operations department were not involved found it difficult to disburse WSS loans or create new clients for the WSS loans.

### Spin off in WSS Financing - Rain Water Harvesting

WSS loan disbursements can have seasonality impact related to rain cycles. On geographic distribution, the parameters that affect were FSPs own outreach in different geographies, severity of water problem, opportunity to harvest rain water, supply of communal water and its reliability as well as socio-economic profile of the area.

Initially the FSPs did not include the rain water harvesting accessories but seeing the demand they started providing loan for gutters, sieve, and pipes. Many clients claimed that the mere water tank would not have been as beneficial as with the complete system of water harvesting structures. Flexibility in the product packaging to provide for this modularity in order to cater to different needs of different customers is key to customer satisfaction. For the FSPs and for the product supplier, it is important to think not just about

## SUSTAINABLE SERVICES

### Finance & Lifecycle Costing

provide the financing or the physical product to the client, but to think, how the product will be used and add value to the client. Taking this broader perspective, some FSPs also included cost of installations particularly in case of rain water harvesting structures. The strange thing about this was that rain water harvesting was not in the scheme of things to be promoted or capacities to be built for this. The graph below shows that disbursements of loans were high in Rift Valley and Eastern province of Kenya which receives ample rain in bimodal frequency but also is a water shortage area.

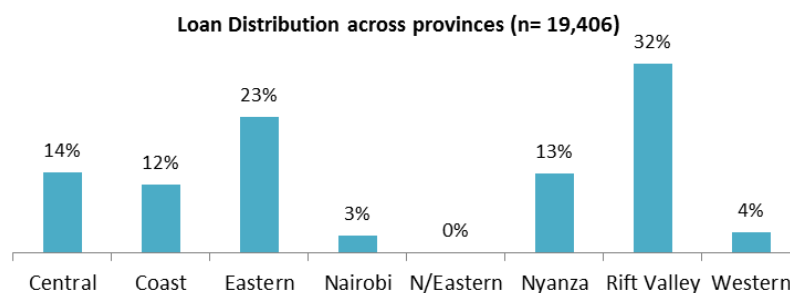

Figure 39: Geographical distribution of loans in Kenya

The big question is ‘why have farmers not widely adopted these apparently cheap and beneficial practices in many other regions? It appeared that an improved communication during the loan process could have even further helped more clients both peri urban and rural to adopt RHT which will help both in drinking water as well as for animal rearing and subsistence farming. There are possibilities of taking this further at community level of better rainwater harvesting. Rainwater harvesting can be efficient as a complementary and viable alternative to large-scale water withdrawals, and reduce negative impacts on ecosystems services, not the least in emerging water-stressed basin.

### Market segmentation

The WaterCredit program was initially conceptualized to cater to household needs of water and sanitation. However, as the project progressed, a common feature was that WaterCredit had demand beyond households as well, from different segments such as:

- Households for consumption: for creation of water and sanitation facility for family consumption
- Households for income enhancement: enhancing water facilities to be able to do some small water based business or homestead farming that could augment household income
- Small entrepreneurs: for establishing water based businesses or water kiosks
- Institutions: such as schools and churches for creation of WSS facilities
- Farmers and farmer associations: for creation of water facilities for drinking as well as irrigation purposes
- Landlords and small builders: for creation of water and sanitation facilities in their rental houses or small housing projects

## SUSTAINABLE SERVICES

### Finance & Lifecycle Costing

Discussions with various WASH-NGOs and government institutions revealed that there were opportunities for WaterCredit for other client segments. These new client segments had demand for credit and this could ultimately lead to higher access of WSS facilities to households. These new client segments include:

- Water scheme operators: In rural areas mostly there were small water schemes like boreholes which were either created by government or by NGOs. These were then operated by entrepreneurs on fee basis and were governed by a local body elected from community called Water Boards. These water scheme operators required credit for maintenance, upgradation or expansion of such schemes. Due to lack of credit many a times the schemes become dysfunctional. Hence, WaterCredit had the potential to cater them as well.
- Private entrepreneurs: There were private entrepreneurs who wanted to develop water schemes or construct toilets and needed credit.

Since, the nature of these clients and need for credit are quite different, it provides opportunity for the FSP to further segment the WSS market and design more customized products for different clientele. Segmenting market and customizing products will help in reaching a larger market and in diversifying risks. FSPs can use the water credits to approach new segments of clients, to get more information and build close ties with the clients (customer loyalty). Market segmentation will also provide an opportunity to vary interest rates across client segments (e.g. as subsidy on interest from government for the very poor).

The findings suggest that WaterCredit had helped people in accessing improved water and sanitation facilities. Most of the borrowers in the study either lacked an improved source or had source which was not sufficient to fulfill the family requirements. Another major finding was the fact that water facilities created with the loan were not just being utilized for drinking purposes but people were increasingly using it for variety of household as well commercial purposes. Usage of water for animals, small poultry business, maintaining kitchen garden, homestead based farming and even selling was found to be common. 30% of the water loan respondents mentioned using water for some commercial activity. Further, people having water also shared it with their neighbors and friends. In 40% cases in the sample such observation was made. Similarly, in case of sanitation too people had benefitted. However, the most important aspect of having an improved sanitation that people felt was enhancement in dignity followed by health benefits and convenience.

## Conclusions and Recommendations

**Client perspective:** Client feedback suggests the criticality of addressing the client preferences and perspectives in product design and delivery. As a whole, there was high level of client satisfaction with the watercredit product. In one FSP where the average client satisfaction was lower compared to other institutions, it was found that major cause of client dissatisfaction was the fact that the financial institutions was not including the cost of installation in the overall product cost and was providing financing only for purchasing the product. This caused significant discomfort for the clients, as they had to look elsewhere for the installation costs, which could be substantial. As a result, there were instances where a client has purchased a water tank, but could not secure money for the installation. The water tank remained unused in this case, while loan repayment for the tank starts right after the tank is purchased. So, clients are paying for the product without being able to use and benefit from it. Small adaptations in the tank design like pre-installed faucet, redesigned cover that allowed it to connect to the rooftop rainwater harvesting system also resulted in greater client satisfaction.

It is telling that clients are not only using water for drinking purposes, they are also using it for small kitchen garden or small income generating activities, water business itself, and also sharing with others. Example from Uganda also clearly identifies a huge untapped segments such as schools or churches who

## SUSTAINABLE SERVICES

### Finance & Lifecycle Costing

are using the products, but who were not really considered at the time of design. If the financial and physical product design takes into account the needs of different customers, the solutions may be even more useful and there may be more demand.

In a market driven approach like this, while the core objective of increasing access to water and sanitation remains unchanged, the messaging around it clearly needs to change to align with what clients value. In the customer feedback, highest number of responds the dignity that comes with sanitation solution more than any other aspect. It is ranked higher than health aspect, higher than convenience aspect, and it is ranked higher than saving time and safety. While for development agencies, it is the health outcomes and saving time is what would probably rank high on the list of priority. But since it is the client who is paying for the product, the appeal and demand for product could be significantly more if the concerned agencies included the dignity, and time saving aspects in their messaging.

#### Unintended client outcomes of the project

- **WaterCredit providing direct opportunity for income enhancement**

In rural areas many people were using the water facilities gained through WaterCredit loans for multiple purposes including drinking but also for farming and animal rearing around their houses. Similarly in urban areas, people were applying for loans to set up small water kiosks. These water entrepreneurs would use the loan to establish new water connections and storage facilities and then sell water in their community. Other clients came in for larger loan proposals involving the digging of boreholes to establish their water businesses.

- **Sharing Water:** 40% families in the total sample mentioned sharing water with people outside their family. Those families sharing water shared it with an average of five additional people beyond their family members.

#### Proliferation of water harvesting practices

The majority of WSS loans have gone into creating new water harvesting facilities and the procurement of water storage tanks. Therefore, the availability of WaterCredit has significantly impacted the practice of water harvesting in Kenya and Uganda.

It was found that given the nature of WaterCredit model it may not reach people who are from very low income segments or people with irregular incomes or residing in remote areas. This is an inherent feature of the model. However, selection of a poverty focused FSPs and segmenting market can still help reach poorer segments through WaterCredit. WaterCredit is highly relevant in context of developing countries where access to WSS services is still low. Design, packaging and delivery of financial and physical products as well as follow up and monitoring are absolutely key to success. As this is a core business of FSP's this is a key strength of the approach. Water being indispensable has higher demand compared to sanitation which is more complex issue and does not have credit as the only bottleneck. Recent cholera outbreak seems to have positively impacted the demand for water purifiers due to massive campaign by government on need for clean drinking water. Many governments, we believe, will greatly benefit from such a model where the government can actively encourage FSPs with an enabling environment in promoting WSS loans through encouraging public-private partnerships to address the issue of WSS services in such countries.

**Acknowledgements:** *The Mid Term Evaluation was carried out by M2i Consulting in August 2013 and the End of the Project Evaluation was carried out by M2i Consulting and Skat Consulting as Sub Contractor of M2i for the MasterCard Foundation in August September 2015. Water.org provided critical supports during the evaluation. Water.Org commented and provided inputs on this paper. The authors also thank the peer review experts who also commented on the paper and helped it improve.*

#### References/Bibliography

ADREC, 2012. *Market Research on Water, Sanitation and Hygiene Products*, s.l.: s.n.

Captiva Africa, 2014. *WaterCredit Case Study Kenya*, s.l.: s.n.

## SUSTAINABLE SERVICES

### Finance & Lifecycle Costing

Kipruto, G. & Komen, R., 2012. *WaterCredit Market Study Report*, s.l.: s.n.

Lebec, A., 2015. *Wielding Impact Investing to Accelerate Access to Safe Water*, s.l.: s.n.

Microsave, 2011. *ECLOF WASH Needs Assessment for Product Development*, s.l.: s.n.

Microsave, 2012. *KWFT Water, Sanitation and Hygiene Needs Assessment Report*, s.l.: s.n.

OECD, 2014. *Trends in Water and Sanitation Related Aid*, s.l.: s.n.

Prime M2I Consulting, 2016. *End of Program Evaluation- WaterCredit Initiative in Kenya and Uganda*, s.l.: s.n.

Traub, G. S.-., 2015. *Investment Needs to Achieve the Sustainable Development Goals*, s.l.: Sustainable Development Solutions Network, A Global Initiative of the United Nations.

UNICEF and World Health Organization, 2015. *Progress on Sanitation and Drinking Water- 2015 Update and MDG Assessment*, s.l.: s.n.

World Health Organization, 2014. *Preventing Diarrhoea through Better Water, Sanitation and Hygiene*, s.l.: s.n.



## SUSTAINABLE SERVICES

### Finance & Lifecycle Costing

# Lessons from using the life-cycle costs approach for rural water supply in DRC through the DRC WASH Consortium

Type: Short Paper

## Authors

*Stephen Jones, Consortium Director, DRC WASH Consortium / Concern Worldwide DRC, [directeur@consortiumwasbrdc.net](mailto:directeur@consortiumwasbrdc.net), +243 (0)819 503 755*

*Gian Melloni, Deputy Consortium Director, DRC WASH Consortium / Concern Worldwide DRC*

## Abstract/Summary

Since 2013, the DRC WASH Consortium, led by Concern Worldwide, has been adapting the life-cycle costs approach into its rural water supply interventions in DRC in order to improve the sustainability of the rural water services developed. The use of the life-cycle costs approach by the Consortium has two purposes: to improve management of water services by community committees, and to permit informed investment decisions by local actors which are based on an analysis of long-term economic feasibility (in addition to technical and social/institutional feasibility). This paper explains how the Consortium has adapted the life-cycle costs approach so far and the initial results from evaluations with 79 water management committees in the first phase of the Consortium’s programme from 2013-15. This analysis highlights the challenges to sustainability that remain, the benefits and weaknesses of the tools developed, and lessons for other actors seeking to use the life-cycle costs approach.

## Introduction

The rural WASH sector in the Democratic Republic of the Congo (DRC) faces two key challenges: scaling-up and sustainability (Black, 2013). The 2015 estimates by the WHO/UNICEF Joint Monitoring Programme were that only 31% of the rural population uses an improved water point, and 29% use improved sanitation facilities (WHO/UNICEF JMP 2015).

To scale-up access, a national rural WASH programme is in place called “Healthy Villages and Schools” (*Village et École Assaini*, VEA). The programme is run through the Ministry of Health (and the Ministry of Education in schools), with UNICEF as the key partner for implementation support. The programme completed its first phase from 2008-2012, and approximately 2,500 villages completed an eight-step community process based on PHAST, achieving the seven WASH “national norms” which are required to be certified as a “Healthy Village” (DFID, 2013). The programme is now in its second phase from 2013-2019, expanding in up to 6,000 new villages.

However, the sustainability of rural WASH services remains a huge challenge (Black, 2013). In 2014, the national programme commissioned a ‘sustainability study’ on phase one villages, 1 to 4 years after they had been certified as “Healthy Villages”. This study showed that only 2% of villages had maintained all seven norms (Hydroconseil, 2014). 33% of boreholes with handpumps were not functioning properly, and only 22% of villages had any collection of funds to cover operation and maintenance. To help address sustainability, a key addition to the national programme in its current phase is post-implementation monitoring for all villages up to three years after implementation.

## SUSTAINABLE SERVICES

### Finance & Lifecycle Costing

The DRC WASH Consortium was established in 2013 as a complementary initiative. The Consortium is composed of five international NGOs: Concern Worldwide (the lead agency); Action Against Hunger (ACF); ACTED; Catholic Relief Services (CRS); and Solidarités International (SI). The Consortium aims to support over 650 villages and 600,000 beneficiaries across 15 rural health zones with funding from 2013-2019 from DFID/UKAid (also the principal donor of the national programme.)

The Consortium has the same strategic aim as the national programme of working with communities to become “Healthy Villages” according to the national norms, but develops and tests alternative implementation approaches in order to improve sustainability, including the use of the Life-Cycle Costs Approach to support decision-making and management. The Consortium programme also proceeds in a series of different intervention phases so that lessons from earlier phases can be fed back in. A previous paper (Jones, 2015) detailed how the Consortium had adapted the Life-Cycle Costs Approach into the DRC context. This paper briefly summarises the adaptation and then presents the initial results and lessons so far.

### Adapting the Life-Cycle Costs Approach into the programme of the DRC WASH Consortium

The WASH Consortium has adapted the definitions of the different cost components of water services proposed by the WASHCost project, as summarized in Fonseca et al. (2011) and shown in Table 1. The Consortium has so far focused on the recurrent costs which occur at service provider (community) level: operating and minor maintenance expenditure and capital maintenance expenditure. For the moment, costs of direct support are not considered in what communities pay (in principle, these costs are covered through the national rural WASH programme’s post-intervention monitoring and support). Indirect support costs at national levels are not included.

Table 1. Type of recurrent costs of water services at local levels according to the life-cycle costs approach (adapted from Fonseca et al. 2011 and Jones 2015)

Life-cycle costs terminology	Life-cycle costs description	Adaptation and terminology used in the approach of the DRC WASH Consortium
Operating and minor maintenance expenditure (OpEx)	Expenditure on labour and materials needed for routine maintenance which is needed to keep systems running, but does not include major repairs.	“Level 1 costs”: Regular costs which are needed at least annually, with a particular emphasis on the management costs required at community level (e.g. costs of fee collection and social marketing), not just hardware costs such as spare parts.
Capital maintenance expenditure (CapManEx)	Renewal, replacement, and rehabilitation costs which go beyond routine maintenance.	“Level 2 costs”: Costs of major repairs which are required typically every 2-5 years.
		“Level 3 costs”: Costs of rehabilitation which is required typically after 10-15 years.
Expenditure on direct support (ExpDS)	Costs of ongoing support to users and local stakeholders, for example local government staff.	For areas where this direct support is in theory provided by local health services, the costs are not included in the estimates for what communities need to pay.

To put this into practice, the Consortium developed a set of tools and training modules for village committees with a focus on financial analysis and planning (which was lacking from previous tools available). This approach is referred to by the Consortium as developing a ‘business plan’ for a proposed water service in a village. The term ‘business plan’ was chosen to highlight the difference with the humanitarian approach that NGO staff in DRC are more used to.

## SUSTAINABLE SERVICES

### Finance & Lifecycle Costing

#### Main results – comparing estimates of Life-Cycle Costs to estimates of communities’ ability to pay

In early 2016, the first phase of villages in the Consortium programme had completed their intervention process and endline evaluations were being carried out, as villages became certified “Healthy” (up to 6 months after the installation of the water point). As of April 2016, 79 communities so far had taken part in the evaluation comparing the estimated long-term costs of their water point with the estimated capacity of the community to cover these costs (according to their ‘business plan’ analysis, which includes the tariff system adopted by the community). These initial results are shown in Table 2.

Table 2. Initial results of the life-cycle costs analysis for the first phase of villages

Estimated capacity of the community to cover the long-term costs of the water point	Percentage of communities, by type of water point		
	Drilled boreholes or hand-dug wells fitted with handpumps (n=44)	Protected springs (n=35)	All water points (n=79)
The community will not even be able to cover operation and minor maintenance costs (“level 1 costs”)	30%	23%	27%
The community will be able to cover operation and minor maintenance costs (“level 1 costs”), but not major repairs (“level 2 costs”).	48%	49%	48%
The community will be able to cover operation and minor maintenance and major repairs (“level 2 costs”) but not full rehabilitation (“level 3 costs”).	23%	29%	25%
Average amount of cash available in the committee’s funds	Mean = 47 USD Median = 36 USD	Mean = 45 USD Median = 39 USD	Mean = 46 USD Median = 39 USD
Estimated yearly cost of running a water point (“level 1 costs”) *	Min = 125 USD Max = 654 USD	Min = 84 USD Max = 531 USD	
Estimated yearly cost of running a water point (“level 2 costs”) *	Min = 275 USD Max = 832 USD	Min = 134 USD Max = 561 USD	
* Variations in cost estimates depend on the technology adopted (e.g. handpump model) and on context-specific variables such as geographic location, cost of access to spare parts etc. Ranges are given to indicate this significant variety in estimates, given the lack of hard data in DRC. Consistent “level 3” costs estimates are not available yet, due to the specific nature of full rehabilitation works in each water point.			

So far there seem to be no significant differences between communities where drilled boreholes or hand-dug wells fitted with handpumps were installed compared to communities where protected springs were installed. The overall data shows the high challenge of sustainability: according to the analyses, 27% of communities will not even be able to cover operation and minor maintenance costs. However, this should be taken into account alongside the fact that at the time of the survey almost all communities have some cash available (mean 46 USD; median 39 USD) for minor costs if required. No village seems to have achieved “level 3 costs” so far, i.e. the capacity to carry out full rehabilitation at its own expenses. This is not too surprising considering the generally low income levels in rural DRC and thus the limited capacity

## SUSTAINABLE SERVICES

### Finance & Lifecycle Costing

to mobilise financial resources locally. Further data will probably cast light on this aspect in the following phases of the project.

Based on available data, population in target villages contribute 0.65 USD/household/month (mean) or 0.5 USD/household/month (median). However, such data need to be taken cautiously: in many villages income-generating activities are also in place to foster financial viability of water points; regularity of contributions changes; mixed systems are often in place (monthly contributions in conjunction with fees by jerrycan); ‘vulnerable’ households are generally exempted; and quality of financial management at the village level varies.

So far the Consortium has encouraged communities to identify the full range of potential costs in their ‘business plans’ (e.g. costs of fee collection and social marketing, not just hardware costs such as spare parts) as a way towards semi-professionalisation of community management rather than relying on volunteerism. However it may be that this approach over-estimates the minimum required for basic operation and maintenance. This was done in the absence of a specific legal framework in DRC: at present, rural water supply tends to be de-facto unregulated in terms of roles, service levels and tariff systems. This may improve gradually in the coming years, since a new Water Law was promulgated in January 2016. The new law prescribes that even though access to water services is a right for all, it is not for free and tariff systems need to be established according to principles of cost-recovery, equity and non-transferability. The law does not indicate any price range or tariff method yet, however it specifies that tariffs should be based on metered consumption and not on flat rates (Journal Officiel de la République Démocratique du Congo, 2016). Such approach, though understandable in principle, is likely to encounter significant implementation barriers in rural settings and wherever water supply is done via self-supply or via point-of-use sources.

For villages in its second phase of the Consortium project onwards, the Consortium has taken into account the challenge of villages which may not even be able to cover operation and minor maintenance costs by selecting at the start of each intervention phase about 20% more villages than originally planned. During the intervention process, the estimates of life-cycle costs of possible water points and the estimated community capacity to pay will be analysed to permit a decision before the final choice of which villages are feasible for installing water points. The impact of such strategy on the capacity to achieve financial sustainability of water points is still to be appraised in full. In the approximately 20% of villages where a water point is not made, alternative solutions such as household water treatment and rainwater harvesting will be explored in more detail.

### Lessons learnt – promoting learning and advocacy at local and national levels

The DRC WASH Consortium is still at an early stage of implementing the life-cycle costs approach. Getting the key concepts understood and adopted has been a process of over two years since the start of the programme and so far has been more important than the exact details of the calculations (which have to be estimates anyway in DRC given the lack of historical data on e.g. frequency of different types of repairs).

At local levels, it has been important to allow new initiatives to emerge which support the overall use of the life-cycle costs approach. For example, some of the Consortium members undertook socio-economic household surveys to provide data which could inform the discussions with communities about what they were willing and able to pay. Others have used more informal focus group discussions to address this issue.

At national level, the Consortium has used its field experiences to share learning and promote debate about life-cycle costs to try to “socialise the concept” in the sector. At its first external sector workshop with over seventy representatives of all key stakeholders in 2014, the Consortium invited an external expert in life-cycle costs to facilitate one day of the workshop and provide credibility for the approach. In 2015, the Consortium followed this up with a workshop on “How to make sustainable investments in the

## SUSTAINABLE SERVICES

### Finance & Lifecycle Costing

rural WASH sector in DRC?”. This initiative helped focus the debate on a key moment in all water projects (the decision about what water points to invest in and where) and share experiences about how life-cycle costs tools could inform this decision.

### Conclusions and Recommendations

*For the DRC WASH Consortium:* The Consortium should undertake more detailed analysis once full results of the first phase of villages are available, and then revise the tools as required for the next phase of the programme and to permit recommendations to the sector on experiences of adopting the tools.

*For the DRC rural WASH sector:* The sector should aim to adopt life-cycle costs tools more widely. This includes tools for key elements of life-cycle costs such as direct support costs. This could be linked to the roll-out of the national post-implementation monitoring process for “Healthy Villages”, as well as the implementation of the new Water Law which emphasises the responsibilities of decentralised local governments in planning, coordination and support.

*For other actors using and adapting the Life-Cycle Costs Approach:* There is a trade-off between harmonising tools and definitions (for example, to allow comparisons across different geographic areas) and permitting adaptation in different contexts so that local actors can adopt and adjust methodologies as needed. It is important that at each level (from community to national), life-cycle costs tools are adapted to the management and decision-making needs of each stakeholder, and that the benefits of using a life-cycle costs approach are evaluated.

### References

- Black, M. (2013). Scaling-up and sustainability, the elusive double quest: “Villages assainis” in DR Congo. *Waterlines* 32, 162–173.
- DFID (2013). Business Case and Intervention Summary: Increasing sustainable access to Water, Sanitation & Hygiene in the DRC. DFID, London.
- Fonseca, C., Franceys, R., Batchelor, C., McIntyre, P., Klutse, A., Komives, K., Moriarty, P., Naafs, A., Nyarko, K., Pezon, C., Potter, A., Reddy, R. and Snehalatha, M. (2011) WASHCost Briefing Note 1a - Life-cycle costs approach: Costing sustainable services, Netherlands: IRC International Water and Sanitation Centre.
- Hydroconseil (2014). Etude de fin de cycle de la Durabilité Programme National Village Assaini & Ecole Assainie – Phase 1 - Note de synthèse - Analyse de la durabilité des Villages Assainis. Hydroconseil, Châteauneuf de Gadagne, France.
- Jones, S. (2015). Adapting the life-cycle costs approach for rural water supply in DRC through the DRC WASH Consortium. 38th WEDC International Conference, Loughborough University, UK, 2015.
- Journal Officiel de la République Démocratique du Congo (2016). Loi n° 15/026 du 31 décembre 2015 relative à l’eau. <http://leganet.cd/Legislation/JO/2016/JOS.13.01.2016.pdf> [accessed 31/08/2016].
- WHO/UNICEF JMP, 2015. Estimates on the use of water sources and sanitation facilities, Democratic Republic of the Congo. World Health Organization and United Nations Children’s Fund Joint Monitoring Programme for Water Supply and Sanitation (JMP), New York and Geneva.

## SUSTAINABLE SERVICES

### Finance & Lifecycle Costing

# A Suite of Tools to Support a Systems-Based Approach to Sustainable Management of Water Service Delivery

Type: Long Paper

**Authors:** Kimberly Lemme, Senior Global Advisor, Sustainability, Water For People [klemme@waterforpeople.org](mailto:klemme@waterforpeople.org), +1.720.488.4571; Kelly Latham, Director of Program Quality, [klatham@waterforpeople.org](mailto:klatham@waterforpeople.org); Keri Kugler, Senior Manager of Monitoring and Evaluation, [kkugler@waterforpeople.org](mailto:kkugler@waterforpeople.org)

## Abstract/Summary

Sustainable Development Goal #6 (SDG6) sets ambitious targets for ensuring availability and sustainable management of water for all, which can only be achieved if the water, sanitation and hygiene (WASH) sector expands its approach from one focused at reaching universal coverage to one that ensures sustainability. Water For People includes in our programmatic approach a comprehensive view of sustainability. This paper presents a suite of tools that we use to plan and monitor the various elements of sustainability of service delivery:

The tools support a holistic, clear understanding of functionality and service levels, financial viability, and water resources management.

- **AtWhatCost:** A life cycle costing tool mapping revenue and expenses of a water system to understand better the levels of financial sustainability for service providers.
- **Asset Assessment Tool:** A spreadsheet that paints a district-wide picture of all water infrastructure and considers its age, functionality, and physical condition to illustrate risks and priorities for future investment needs and planning by the service authority.
- The annual service delivery **monitoring activity** allows service authorities and service providers to measure progress and trends in water service delivery. It is a critical tool in measuring levels of service and as a basic measurement of sustainability.
- **Sustainable Services Checklist:** An Excel-based score card reflecting the institutional strength of WASH service delivery stakeholders. Through data analysis and direct interviews of the stakeholders, the Sustainable Services Checklist is an indicator used to reflect progress to the delivery of sustainable services, and ultimately when external intervention can exit.
- The **Water Resources Inventory tool** is designed to establish a foundation for developing district water resource management plans. In Honduras, this tool has led to the purchase and protection of high priority drinking water catchments.

Each of these tools can stand alone to address an individual element of sustainability of service delivery. As a suite of tools taken together, they support a holistic approach to implementing system change in rural water service delivery.

## Introduction

Sustainable Development Goal #6 (SDG 6) sets ambitious targets for ensuring availability and sustainable management of water, sanitation and hygiene (WASH) sector expanding its current focus on infrastructure investment towards sustainable service delivery.

## SUSTAINABLE SERVICES

### Finance & Lifecycle Costing

At Water For People, we have been implementing, evaluating, and evolving our district-level systems-based approach<sup>67</sup> to sustainable water service for the past 5 years. We currently work in 9 countries and 30 districts in Africa, Asia and Latin America. Global progress since we started our district-level approach is summarized online at <http://eftracker.waterforpeople.org/>.

We have consistently measured progress towards universal access in 30 districts since 2012. During this time, two districts have achieved universal access to adequate services, which was a major breakthrough across our organization. It showed us and our partners that the impossible was possible.

Despite these achievements, we face the very real risk that service levels will drop. Although sustainable water service has always been our focus, we have learned the need to expand our programmatic approach to more directly incorporate a more comprehensive view of sustainability that starts earlier in the process of planning and working with a local government. Central to this planning process are the tools that support a systems-based approach. The suite of tools that we use focus on four primary themes – monitoring service delivery, financial management and water resources management.

#### Conceptual framework behind the tools

All of the tools presented here – the service level monitoring tools, the institutional measurement tools, the financial management tools, and the water resources management tools – link directly to our organizational monitoring framework which provides a holistic view of a district's ability to provide services over time in a sustainable way on an ongoing basis.

Service level monitoring measures whether the service people get now is adequate. The data from this monitoring is essential in understanding how to improve the current level and lead to continual increases in water services over time. Sustainability of services starts with the adequacy of the current service, but the other monitoring tools are complementary in understanding that service can be maintained over time.

Institutional sustainability, measured through a combination of service level monitoring data and interviews with service authority and service providers, is most simply put as a way to look at the management and financial structures within the two institutions.

Financial sustainability of water service delivery is a key challenge with overall system sustainability. In conjunction with WASH sector partners over the past three years, Water For People has developed and been working with a suite of tools to support community and district financial planning. Conceptually, the suite of tools allows service providers and district WASH officers direct access to information needed to strategically plan and manage WASH services. Without proper life cycle financial calculations and asset inventory, a district is ill-equipped to plan and budget appropriately to support the needs of each community within a district.

Finally, the environmental protection of catchments that provide drinking water is another critical piece to sustainability. Treatment systems and infrastructure improvements are costly alternatives to preventing degradation of the source area. If the source degrades, the system will be abandoned regardless of the quality of the infrastructure or the capacity of the service provider or authority. Climate change puts further strain on water resources and heightens the need for proactive approaches for protecting drinking water sources. Catchment management can occur at many different scales from one community and one water source to large river basins or aquifers that include hundreds of sources with different competing uses. This paper presents a Water Resources Inventory tool that is focused on improving management of

---

<sup>67</sup> District-level is any defined political boundary, usually just below the state or departmental level with an established responsibility for rural water services. Although in different locations it can be called a municipality, a district, or a sub-county, Water For People uses the term district-level throughout this paper for consistency. Water For People defines a systems-based approach to shift the focus of our work from infrastructure to include all of the systems needed to effectively operate water systems and keep water flowing over time.

## SUSTAINABLE SERVICES

### Finance & Lifecycle Costing

water resources at the district level, as district governments make decision on water system investments. It provides the needed data to develop site-specific and actionable protection measures in order of priority.

The following table lists the key tools that support our systems-based approach to achieving SDG 6 in target area. An embedded necessity in each of these tools is the capacity of the responsible institution, which often means investment in trainings and capacity buildings to ensure the tools are embraced and used over the long-term. The goal of this paper is to share the tools with other organizations that can use and adapt them to their context.

Tool	Description
Service Level Monitoring	A set of indicators and scoring methodology to monitor levels of service over time.
Sustainable Services Checklist	A list of indicators and metrics to monitor institutional sustainability over time. Its focus is to determine if a service provider and service authority exist and at what capacity they are functioning. Water For People is using this checklist as one way to determine the ideal time to exit a district.
AtWhatCost	A spreadsheet that allows water committees/service providers to assess whether current spending on operation and maintenance is adequate and to set a tariff that is both fair and sufficient to cover the operation and maintenance costs, as well as a percentage of capital maintenance costs.
Direct Support Cost tool	A spreadsheet to help districts establish budgets that cover all roles and responsibilities associated with water service delivery, such as monitoring, oversight, delegated regulation, planning, local by-law development and otehrs.
Asset Analysis	A spreadsheet that allows districts to understand and prioritize future infrastructure investment needs for eventual major repairs and system replacement
Water Resources Inventory	A database of all current and future potable water sources in a district to better align supplies with demands and prioritize protection measures

### Context, aims and activities undertaken

This section presents a description of each of the tools, our experience in applying them, and a sample of the findings.

#### Tool 1: Service Level Monitoring

**Description:** We monitor services through indicators that reflect the level of service in aspects of 1) presence of improved water sources, 2) quantity, 3) quality, 4) reliability/continuity, and 5) accessibility and include the following. Data on these indicators is collected through FLOW, which is also the platform for validation and processing the data. Jointly, they form our main service level monitoring tool.

Water Service Level Metrics	Points Possible
Presence Of An Improved Water Point/System	1
Number Of Users Meets Standards	1
At Least 95% Of The Community Members Have	1



## SUSTAINABLE SERVICES

### Finance & Lifecycle Costing

Access To An Improved Water Point/System	
There Is Enough Drinking Water Every Day Of The Year For Every Community Member	1
The Water Point/ System Was Down For 1 Day Or Less In The Last 30 Days	1
There Are No Current Problems With The Water Point/System	1
The Quantity Of Water Available Meets Standards	1
The Quality Of Water Meets Standards (E. Coli, Bacteria Presence/Absence or Residual Chlorine)	1
Water Is Available On The Day Of The Visit	1
Time It Takes To Collect Water (Round Trip) Meets Standards	1
Total	10

These metrics are aggregated for each water point/system and based on a 10 point scale it is given the following classification.

- No Improved System – 0 Points
- Inadequate Level of Service – 1 Point
- Basic Level of Service – 2 to 6 Points
- Intermediate Level of Service – 7 to 9 Points
- High Level of Service – 10 Points

The goal for Water For People is to achieve 7 or more of these indicators (so at least an intermediate level of service) in all water points in a district.

**Application:** Water For People first began systematic monitoring of water and sanitation projects in 2006. Over the next 6 years we learned significant lessons, most notably the importance of mobile data collection, which prompted the development of Akvo FLOW. By 2012, we expanded to a full district approach to monitoring, where we monitored water levels of service at the community and household levels across whole districts regardless of who installed the infrastructure. Water For People collects its Service Level Monitoring data during an annual data collection exercise, either through a sampling or census of all water services in the 30 districts where Water For People currently works. This has been done since 2012, allowing our programming to be informed by trends over time and annually updated information.

**Sample Findings:** The graphs below show both level of access (anywhere with an improved water source) and level of service (those with an intermediate or high level of service) over time in a sampling of the areas where Water For People is implementing work.

### Uganda (Kamwenge District)

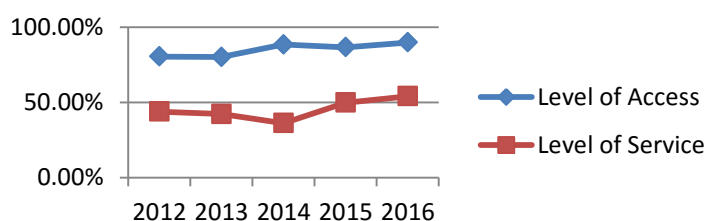

SUSTAINABLE SERVICES

Finance & Lifecycle Costing

### India - South 24 Parganas District (Sagar and Patharpratima Blocks)

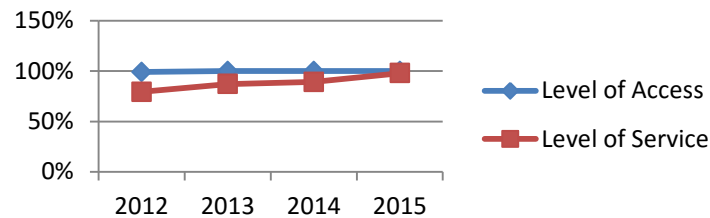

### Peru

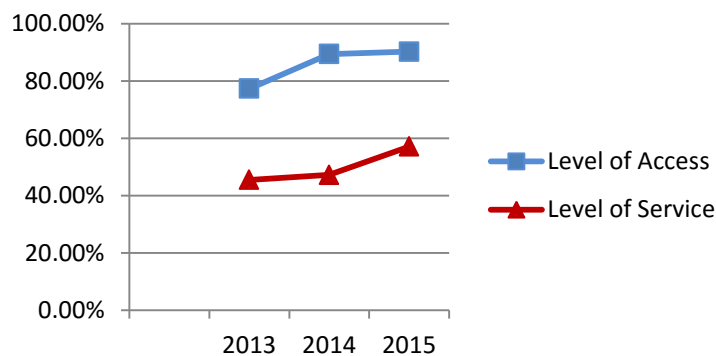

The Uganda example in 2014 illustrates the importance of measuring both indicators in order to understand the quality of the services being delivered. It is possible when large infrastructure investments happen, there can be a slip in the quality of services if the focus remains on hardware. As seen in the India graph above, as a district gets closer to reaching full coverage and sustainable service delivery for water, the level of service and the level of access will likely be more in line with one another. As can be seen in Peru from 2014-2015, when work focuses on sustainable services over the rush to 100% coverage, it is possible to see a sharper increase in the level of service and a plateau in the level of access.

The results of all monitoring data collected since 2012 in each district are available here - <http://efracker.waterforpeople.org/>. The data show that when looking at access alone, 11 districts have achieved 100% coverage, while three districts have achieved an intermediate or high level of service. Therefore the service delivery monitoring provides us with the priorities to focus on.

- Reaching the hard to reach and marginalized families within a community - this is based on the challenge of achieving the 95% access indicator.
- Setting and compliance with sustainable tariffs, based on the challenges identified when reflecting on the causes for the low scores on down time and other system problems. .
- Improved water resource management and water safety planning, based on the challenges with the water quality and quantity indicators.

These example priorities are consistent with previous years and shape our efforts to focus on the subsequent tools presented in this paper.

**Tool 2 – Sustainable Services Checklist**

## SUSTAINABLE SERVICES

### Finance & Lifecycle Costing

**Description:** The Sustainable Services Checklist is an institutional scorecard in checklist format that is scored annually through data review and interview of key stakeholders, mainly service providers and service authorities. This tool has allowed Water For People to holistically understand our various data sets in a consistent manner across different contexts and score the effectiveness of the institutions in delivering water services. The intention is to provide an objective indication of the sustainability of service delivery in a district, as well as a score for Water For People to understand the most opportune time to exit a district.

**Application:** The Sustainable Services Checklist has been tested in all countries where Water For People works in 2016. The nine global measurement indicators are consistent across all country programs, and the metrics which are sub-indicators of the nine categories are contextualized to the district level in order to measure the unique structures and conditions in that district. The testing consisted of an internal discussion and mock scoring, conducted by our country program staff and regional management. After final tweaks, we plan to conduct the baseline in 2017 as part of our data collection and monitoring reflection work.

**Sample Findings:** The initial scores emphasize the importance of focusing on sustainability before reaching full coverage with adequate services. Only a few of the indicators were met in most country programs which shows that we have succeeded in most places in establishing a service authority. This indicates to our internal review teams that there is much work to be done in the areas of finance and management and how services are best delivered. Water For People will have more concrete data sets to work with after our 2017 monitoring, from which we will build our way forward to increasing sustainability of services.

### 9 GLOBAL INDICATORS

1. Service Authority – Structure
2. Service Authority – Finance
3. Service Authority – Management
4. Service Authority – Monitoring
5. Service Provider – Structure
6. Service Provider – Finance
7. Service Provider – Operations and Maintenance
8. School and Clinic WASH Services
9. Water Resource Management

### Tool 3 - AtWhatCost

**Description:** AtWhatCost is a spreadsheet that allows water committees/service providers to understand the life cycle costs of delivering adequate service levels and to also set a tariff that is fair and sufficient to cover at least their operation and minor maintenance costs, and in some cases a certain percentage of capital maintenance costs, based on life cycle cost analysis. The key outcome of AtWhatCost is the understanding that it takes a multi-year perspective (10-20 years) recognizing that capital maintenance comes at irregular intervals, but requires bulky expenditures. An annual review of income and expenditure would not be able to cover these irregular and bulky investments adequately – hence the multi-year perspective. It has flexibility to input various cost assumptions and expected revenue streams to show a cash flow for each system.

**Application:** AtWhatCost has been applied in all of our country program contexts from rural Latin America to peri-urban Africa. It is a tool intended for service providers and the local government to

## SUSTAINABLE SERVICES

### Finance & Lifecycle Costing

manage in the long-term. In some places district WASH staff have begun using this tool, but it is currently still managed for the most part by Water For People staff. We are building in training plans in the coming year to support the district management of this.

**Sample Findings:** We have seen AtWhatCost successfully used to advocate in rural Malawi for improved tariff payments among communities reluctant to pay. Our work in Bolivia has also seen increased water committee financial viability. Using the basic numbers from the AtWhatCost tool, district water office staff working with communities were able to better understand and plan for the lumpy costs of major repair and replacement. In addition, service providers are more able to understand the replacement costs and to understand their role in supporting a portion of the replacement costs with tariffs that are set at a sustainable and appropriate level. An example below illustrates the visual graph that is a result of an AtWhatCost cash flow calculation for a rural Handpump in Malawi.

### Annual Income and Expenditures

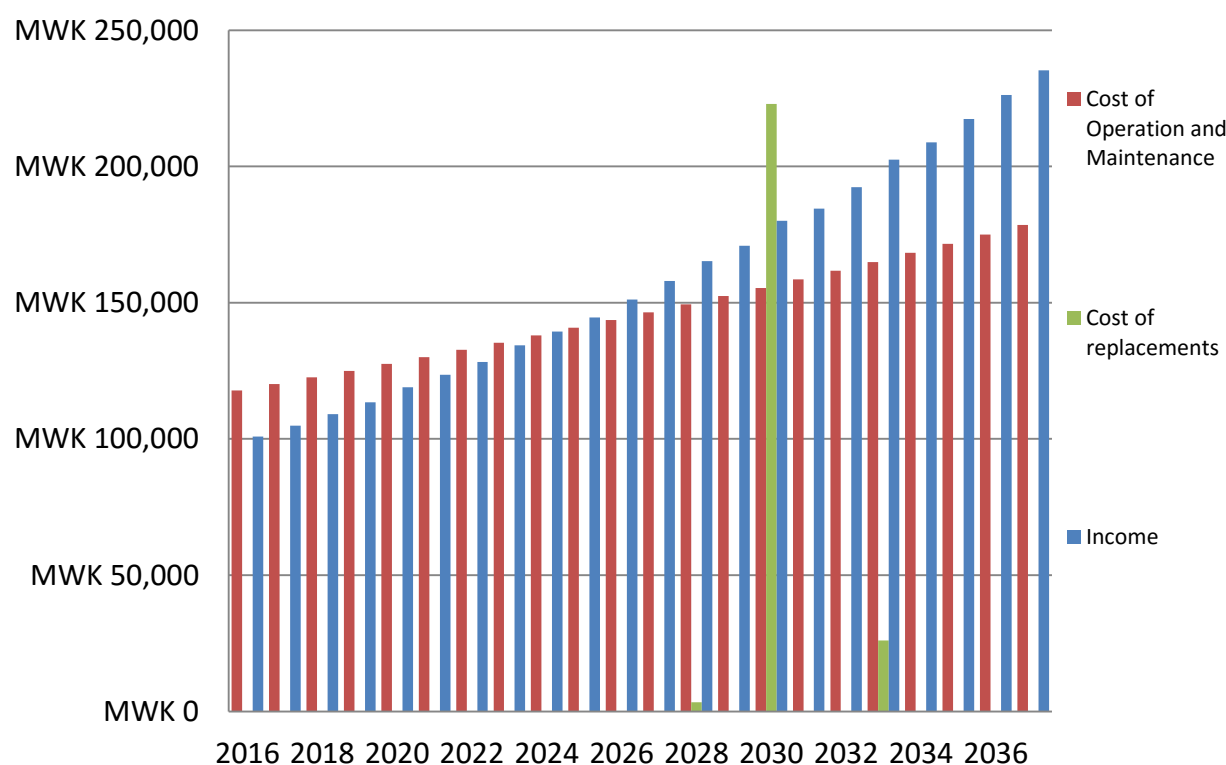

### Tool 4 - Direct Support Cost

**Description:** The Direct Support Cost tool is a worksheet to estimate the budget needed by the district government/service authority to fulfil all its roles with respect to water service delivery. Costs range from human resources, water catchment protection activities, monitoring, oversight, post-construction support to service providers, and major replacement costs of water service delivery infrastructure. The tool compares the current allocation of budget – both in terms of staffing and expenses for transport, per diems and others – with an ideal budget. The resulting gap analysis allows for discussion and advocacy of increasing or more effectively allocating district water office funding which is an important first step in advocating for sufficient public funding allocated to water services by the service authority.

**Application:** The Direct Support Cost tool has been used for the past 3 years in each district. This tool is currently used as a conversation starter and an advocacy instrument with the local government about

## SUSTAINABLE SERVICES

### Finance & Lifecycle Costing

WASH-related allocations for ongoing running costs of service delivery. This tool does not take into account the capital costs for infrastructure work.

**Sample Findings:** We have seen various successes and challenges with the use of this tool. It is useful to compare side-by-side the gap the district has in funding water support services. However, in our Nicaragua country program, it has shown to effectively increase the amount of staff and budget the municipality can allocate to water support services. In India, our staff has struggled to authenticate the numbers because governmental budget numbers (including staff salaries) is not publicly available. There has also been success in our Uganda country program in the district acknowledging the needed increase in technical staff to support water service delivery from the service authority level. However, the one district where we are working still lacks the sufficient number of staff and support costs, like fuel to oversee implementation work in the field.

### Tool 5 - Asset Analysis

**Description:** An inventory tool that documents the age, physical state and functionality of all water infrastructure in a district, to understand and plan for the eventual capital maintenance works, and provide a prioritized list of actions to keep water flowing over time.

**Application:** The asset analysis tool being used in our country program is now being piloted in Uganda, India, and Peru in order to ensure the technical pieces all function as designed. This was used in one district in Honduras early in 2016 and the results were helpful as we worked with the municipal government to understand the long-term maintenance needs of the water systems in the municipality.

**Sample Findings:** Water For People’s experiences, albeit limited to the work in Honduras and the current pilots, shows that the tool will allow for a high-level assessment of the state of the municipal water systems – based on age, level of service, and physical state. This visual scorecard has supported municipal WASH offices to easily prioritize their investments in system rehabilitation and replacement. It is more support than the technicians have had, because the priorities are based on methodologically collected data.

Level of Service	Age-based Risk	Replacement Priority
1 Nivel de Servicio Intermedio	Bajo Riesgo	Baja Prioridad
3 Nivel de Servicio Intermedio	Medio Riesgo	Baja Prioridad
1 Nivel de Servicio Intermedio	Bajo Riesgo	Baja Prioridad
3 Nivel de Servicio Intermedio	Alto Riesgo	Media Prioridad
2 Nivel de Servicio Intermedio	Medio Riesgo	Baja Prioridad
2 Nivel de Servicio Intermedio	Medio Riesgo	Baja Prioridad
3 Nivel de Servicio Intermedio	Medio Riesgo	Baja Prioridad
2 Nivel de Servicio Intermedio	Bajo Riesgo	Baja Prioridad
2 Nivel de Servicio Básico	Medio Riesgo	Media Prioridad
3 Nivel de Servicio Intermedio	Medio Riesgo	Baja Prioridad
3 Nivel de Servicio Intermedio	Bajo Riesgo	Baja Prioridad
3 Nivel de Servicio Intermedio	Bajo Riesgo	Baja Prioridad

### Tool 6 - Water Resources Inventory

**Description:** A database of all current and future potable water sources in a district, including characteristics of the source (source type, location, capacity, etc.), characteristics of the recharge area (land use and topography of delineated catchment), other contaminant sources (such as agrochemical applications, latrines, etc.) and existing protection measures (such as catchment committees, field demarcation of protection area, source water protection plans in place, etc.). The purpose is to provide

## SUSTAINABLE SERVICES

### Finance & Lifecycle Costing

the baseline information necessary to identify and prioritize contextualized and impactful protection measures.

**Application:** Various versions of Water Resources Inventories have been implemented in 5 districts over the past 4 years.

Sagar Island, India – 2013 – Data is focused primarily on source characteristics and quantity issues and was collected with support of volunteers from World Water Corps (Water For People’s volunteer group).

Rulindo, Rwanda – 2016 - Data includes full set of data elements listed in the current inventory in addition to aquifer characteristics with modelled delineation. Data was collected by hired Rwandan consultants in coordination with district government and Water For People staff.

San Rafael del Norte, Nicaragua – 2014 – Data is focuses primarily on source characteristics and was collected with support from volunteers from World Water Corps.

El Negrito, Honduras – 2015-16 – Data includes source and characteristics of delineated catchments and was collected by district government with support from Water For People staff.

Cascas, Peru – 2014 – Data includes source characteristics along with delineation of larger catchment areas for modeling purposes. The data was collected by volunteer water resource modelers.

The current version of the inventory (available [here](#)) reflects the lessons learned from these experiences but has not yet been implemented in its current form by a district government.

**Sample Findings:** The application in El Negrito, Honduras is most similar to the current form of the Water Resources Inventory presented here and best illustrates the potential impact from developing this type of inventory. Catchment management is an integral part of system administration in El Negrito largely because of the commitment to source protection from the Mayor, Delvin Salgado. A municipal catchment committee (*COMIC – Comité de Compra de Micro Cuencas*) was formed in 2013 with the goal of (1) uniting community water boards in the protection of natural resources and (2) aligning the municipality with the national government’s Institution of Forest Conservation (ICF). The primary function of the COMIC is to purchase land to protect drinking water catchments with money collected from the communities through an additional fee per month per user and from the municipality. In order to purchase and legally protect drinking water catchment areas, a water resource inventory must be completed that delineates the catchment area. To date, 5 drinking water catchments have been declared protected areas and land purchases are in process. Challenges exist, especially with full participation with the additional tariffs for land purchase, the pace of land purchases and negotiation conflicts, but the municipality has shifted and the priority is clear - drinking water watersheds must be protected, the steps are clear to achieve this goal, and the first step is to complete a Water Resources Inventory.

### Main results and lessons learnt

Through our experience developing, testing, training and implementing these tools to varying degrees, we have learned several lessons.

- The process for every one of these tools has been **iterative and evolutionary**. The pilot tests and development included a lot of field staff input, the reality is they will continue to be refined and improved upon as we continue to understand more. The purpose of the tools doesn’t change, but the functionality, the methodology and the inputs evolve – which has taught us that patience and flexibility are key to the implementation of any tool.
- **Contextualization for a region, country, or even district** has shown to be more important than maximizing user interface and tool simplicity. Therefore, most tools have multiple versions based on the local context. We have individual versions of the Sustainable Services Checklist for each of our 30 districts. Water For People has no expectation our tools will be used without modification by others. Instead, we hope they serve as a base for others to build upon.

## SUSTAINABLE SERVICES

### Finance & Lifecycle Costing

- **Technological differences also require individualization within the tool.** In addition to the need to contextualize according to geography, differences between community wells and piped networks with household connections are also significant. Consequently, some of our tools are duplicated to accommodate this difference.
- **Instructions, training, better instruction and more training** are always needed no matter how simple the tool may seem. Time must be allocated for both with the rollout of any new tool. The key to scaling up and replication of use is dependent upon the adoption of the tool by the local government. Therefore, initial trainings are similar to “train the trainers” in addition to direct trainings. Related to this lesson, **sufficient resources are necessary for a wide roll-out and training across multiple contexts.**
- **Need for basic computer software skills, so audience is limited to local and national government officials and NGO staff.** These tools require a computer and use of Excel and are focused at district level management, who can then work with community water committees/service providers to collect information and present findings. These tools are intended for the use of the service authority so they can most effectively carry out their responsibility for providing adequate water service delivery to all.

### Conclusions and Recommendations

- Service level monitoring is a way of finding out what users get now, but is insufficient to assess whether users will get the same in future. Therefore it is important to balance the tools focusing on service levels and those focusing on sustainability.
- There is a need to have tools to assess the probability that services will continue at a high level in the future. That focus on sustainability is how we have landed on the categories of tools we present here: institutional, financial and environmental/water resources
- The tools need to go into the depth of each element of sustainability, but their results, taken together should provide holistic assessment of future sustainability

The sample findings differ across the countries, but first results indicate:

- There is a trade-off between access and service levels. If you improve service levels, access growth may stagnate. Or, if you only invest in access, service levels may go down
- Of the different life-cycle costs, operation and minor maintenance can most easily be covered by users. But, direct support and capital maintenance are most underfunded
- Institutional sustainability proves challenging because it encompasses many of these issues into one or two entities. Clearly outlining roles and responsibilities is the first step – and who is responsible to cover what costs. Once those are understood and accepted it is a simpler step to understand where the funding comes from to cover the costs and ensure proper capacity of skills in the government.

There are three main recommendations based on our experiences to-date.

1. Tools are most effective when used and implemented at the district or municipal level.
2. Contextualization and localization is key, but plan for the additional resources for the extra work that is required for this level of individualization.
3. Engaging long-term stakeholders from the start results in an easier shift to ownership and up-take of the tools at a larger scale more quickly.

Each of these tools can be made available to interested organizations in the version that best matches their context. We hope others in the sector will benefit from our learnings as we work together to achieve SDG6.

### Acknowledgements

## SUSTAINABLE SERVICES

### Finance & Lifecycle Costing

The following organizations have contributed to the suite of tools presented in this paper: Akvo, IRC, Aguaconsult, Inter-American Development Bank (IDB)- Multilateral Investment Fund

### References

*Para Todos, Por Siempre* initiative in Honduras: <http://ptps-aps.org/> (in Spanish only).

Joint Blog on the costing tools <http://www.ircwash.org/blog/everyone-reached-financing-remains-forever> (English) and <http://es.ircwash.org/blog/%C2%BFel-vaso-est%C3%A1-medio-lleno-o-medio-vacio> (Spanish)

WASH Agenda For Change blog (Spanish) <http://es.ircwash.org/blog/construyendo-la-ruta-para-la-cobertura-total-y-para-siempre>

The steps to institutional strengthening at municipal level <http://es.ircwash.org/blog/%C2%BFpor-qu%C3%A9-no-ha-sido-del-todo-sostenible-la-institucionalidad-local-en-agua-y-saneamiento-en-los> and <http://es.ircwash.org/blog/parte-ii-%C2%BFpor-qu%C3%A9-no-ha-sido-sostenible-la-institucionalidad-municipal-en-agua-y-saneamiento-en>

Smits, Stef. “Getting towards universal coverage : a roadmap with tools : illustrated by experiences from Honduras” <http://www.slideshare.net/ircuser/getting-towards-universal-coverage-by-stef-smits>



## SUSTAINABLE SERVICES

### Finance & Lifecycle Costing

---

# Towards building a tariff methodology for rural water and small Service providers in Colombia

---

Type: Short Paper

**Authors:** Alejandro Gualy Guzmán, Ex Expert Commissioner, Water and Sanitation Regulatory Commission, Colombia, [agualy@gmail.com](mailto:agualy@gmail.com), (57) 311 898-4095. Miguel Vargas Ramírez, Senior Water and Sanitation Specialist, World Bank, Panamá, [mvargasramirez@worldbank.org](mailto:mvargasramirez@worldbank.org), (507) 831-2004.

### Abstract/Summary

This document presents the Colombian experience in building a tariff methodology for rural and small town water service providers. For the first time in Colombia, a participatory approach that included water service committee leaders was utilized to develop sector regulation. As part of the approach, small service providers chose different viable alternatives that were later transformed into legal regulation through public citizen consultation. For example, one alternative providers considered was whether to adhere to regulation issued by a central regulator or to follow their own self-regulation rules. The providers preferred adhering to the former to avoid internal conflicts in setting tariffs. In addition to shaping the regulatory approach, the providers' participation helped ensure that the regulatory norms were understandable and easy to apply. The new participatory approach for the formulation of rural regulation in Colombia was particularly important in light of the weakness of past regulation for the rural sector.

### Introduction

Under Colombia's water and sanitation legislation, the Water and Regulation Commission (CRA) is responsible for setting the regulations, guidelines and methodologies for water service providers throughout the country. Every four years, the President of the Republic appoints four Commissioners. The fixed, four-year terms of these Commissioners does not coincide with the presidential elections, providing a degree of political independence. While the CRA defines policies, the Superintendence of Domiciliary Services (SSPD) is responsible for the control, inspection and oversight of service providers.

Since 1994, tariff frameworks have been divided in two segments: large service providers (large and intermediate cities) and small service providers including rural areas. Small providers are defined as those that attend up to 5,000 subscribers (approximately 20,000 people). Colombia is currently in the process of rolling out a new tariff structure for small service providers that unlike the previous two structures resulted from a participatory approach.

### Description of the Case Study – Approach or technology

In Colombia, 11 providers service 70% of the country's population and over a thousand providers service the remaining 30% of the population, who are based in small towns and rural areas. The exact number of service providers in small towns and rural areas, however, is unknown complicating the regulation and oversight of their service.

With over 20 years of implementing regulatory experience, service providers in urban areas have begun providing more efficient and continuous service while expanding quality and coverage. This is due to a combination of factors including adequate financial resources for providers, the cities' institutional capacities, and the potential urban areas provide for economies of scale and agglomeration. In Colombia, sector policy and resources have traditionally been focused on the urban sector.

## SUSTAINABLE SERVICES

### Finance & Lifecycle Costing

Regulation has not spurred such positive change in small municipalities and rural areas. The regulatory approach was developed with urban areas in mind and its application in rural areas has been difficult. The rural sector also suffers from a lack of public policy, low resource allocation, limited inter-institutional capacity and political interference.

The CRA, the Economic Commission for Latin America and the Caribbean, the Inter-American Development Bank and the SSPD cited low affordability levels, limited technical and administrative capacity, lack of planning by providers, insufficient data reporting, service atomization, lack of specific policies, limited support and technical assistance by the central government, and the complexity of tariff regulation as the main reasons for service providers' weak performance in rural areas.

There was a clear need to strengthen regulation, policy formulation, resource mobilization and service sustainability in small town and rural areas. As a result, the CRA embarked on a process of reassessing the regulatory approach and developing a new regulatory framework.

In 2014, Colombia, in negotiations with the Organization for Economic Co-operation and Development (OECD) agreed to increase citizen participation when enacting new regulation, given that previously citizen participation *only took place once* the Government made an initial proposal. In light of this agreement, the CRA adopted a participatory, bottom-up approach for the development of a regulatory methodology for the rural sector. The CRA invited approximately 30 leaders of rural and small towns water committees and federations to a workshop to discuss the key elements for the new regulatory framework. The workshop covered institutional issues as well.

**Regulatory Issues.** The following five themes (in bold) and the main results of the discussion on each theme are presented below.

1. **Resources required for good service provision.** There is a general lack of infrastructure at all service levels and financing structural improvements via tariffs is not viable. Tariffs do not cover O&M costs, and there is no access to subsidies. Water sources are not being protected and water source environmental licensing is cumbersome. There is no training or technical assistance for providers. Educating users on their rights and responsibilities is a priority.
2. **Required actions to improve metering and tariff collection.** Campaigns on rational water use and metering are necessary. Meters and commercial software to control water consumption should be given or subsidized. It is also important to implement measures for cutting, suspending and reinstating services in rural areas.
3. **Convenience of following a regulator's rules versus each provider developing its own rules.** The group found implementing the central regulator's regulations more convenient as it would facilitate tariff calculation and promote service sustainability. The participants rejected the self-regulation model because of the difficulty agreeing on tariff levels in their communities.
4. **Difficulties applying current regulatory norms.** Existing regulatory methodologies are complex, making their implementation difficult. There is currently no training on regulatory issues. Increasing tariffs to cover investment costs could cause conflict within the communities as well as collection problems.
5. **Other aspects important for good service provision.** Municipalities should process subsidies and allocations efficiently to ensure providers do not suffer from a lack of financing. The Government should cover infrastructure costs and policies and norms specifically for the rural sector should be enacted.

**Institutional Issues.** The following six themes (in bold) and the main results of the discussion on each theme are presented below.

1. **Perception of the role of the State.** Financial support to municipalities has become politicized, complicating the transfer of funds. Support from regional governments is low or non-existent. The central government does not reach rural service providers or does so sporadically. Too much red tape is required to obtain environmental licenses to use water sources. There is a lack of institutional coordination in the rural sector.

## SUSTAINABLE SERVICES

### Finance & Lifecycle Costing

2. **The role of the State.** Support to rural areas by the State should be done in a coordinated manner. Policy design should involve the Community Organizations for Water and Sanitation Services (*Organizaciones Comunitarias de Servicios de Agua y Saneamiento -OCSAS*). Infrastructure and tariff subsidies should be transferred directly to OCSAS.
3. **Main challenges to rural water policy.** The policy should be focused on the communities. There should be a direct relationship between the Government and the communities to simplify the process of accessing resources and to avoid corruption. The participants proposed creating Public Community Associations for the management and optimization of infrastructure works in rural zones.
4. **Organization structure of water service providers in rural areas.** Participants proposed maintaining the OCSAS structure but improving the legislation around the structure.
5. **Oversight and control mechanism for rural service providers.** Monitoring systems should be seen as a helpful tool rather than a mechanism for generating sanctions. In addition, prior to sanctioning a provider, agreements to improve services should be made. If the recommendations are not adopted, then a sanction should be applied.
6. **Other important aspects for the institutional framework.** Mechanisms to monitor the transfer of municipal resources and subsidies for infrastructure works should be created. The participants proposed a decentralized institutional scheme in order to attend rural communities' needs.

The workshop's conclusions on regulation were used to prepare the Regulatory Proposal for small municipalities and rural areas in the country (Resolution CRA No.717 of 2015). This proposal has been presented for public consultation and citizen participation in different areas of the country. Currently, minor adjustments are being made that incorporate citizen feedback; a final resolution is expected to be published by the end of the year. The workshop's conclusions on institutional issues were sent to the Ministry of Housing, City and Territory to serve as input for the preparation of rural water public policy. An unintended result of the workshop was the formation of an association of rural water leaders, the Colombian Confederation of Communal Water and Sanitation Service Providers (COCSASCOL).

### Main results and lessons learnt

Government policy proposals should be developed using a bottom-up, participatory approach. Benefits to this approach include: (i) the collection of information directly from the regulated party; (ii) the pre-identification of potential bottlenecks and difficulties; and (iii) ownership of the policy by the providers.

### Conclusions and Recommendations

- **REGULATORY ISSUES.** It is important that a regulatory agency for rural water and sanitation services exists and sets tariffs for the rural sector. Regulatory tariff methodologies should be easy to apply and understand. Tariffs charged in rural areas should cover O&M costs. Infrastructure investments should be the central government's responsibility. Otherwise, service provision in rural areas will not progress given that the population cannot afford to cover infrastructure investments.
- **INSTITUTIONAL ISSUES.** The central government should provide permanent training and technical assistance programs for OCSAS. This assistance should cover administrative and technical issues and support enhanced coordination among sector institutions. The environmental licensing procedure should be made more efficient. Transfers and subsidies from the central government should be agile and transparent. Rural public policy should be prepared in conjunction with OCSAS. The policy should include feasibility studies for public-community partnerships, direct wire transfers for tariff and infrastructure subsidies, and permanent training and assistance programs on management issues.
- **OTHER ISSUES.** Monitoring activities should be carried out to assist OCSAS and help them develop improvement plans in an effort to avoid future sanctions for service failures. Reporting mechanisms and systems should be simple and should serve to identify the number of providers and administrative

## SUSTAINABLE SERVICES

### Finance & Lifecycle Costing

and technical standards, as well as to define a baseline to allow for proper monitoring over time. Users need to be trained on their rights and obligations, payment culture, environmental issues, rational use of water resources and the benefits of metering.

#### References

Decree 1077 of 2015 "For the issuing of the Decree from the Housing, City and Territory Sector"

<http://www.alcaldiabogota.gov.co/sisjur/normas/Norma1.jsp?i=62512> Recovered on 10 de May 2016.

Ley 142 de 1994. Régimen de Servicios Públicos Domiciliarios.

<http://www.alcaldiabogota.gov.co/sisjur/normas/Norma1.jsp?i=2752> Recovered on 10 de May 2016

Resolution CRA 717 of 2015 “To present a resolution in a tariff methodology for providers of water and sanitation services that serve up to 5,000 accounts in the urban áreas and that provide services in the rural áreas”, fulfilling compliance to the numeral 11.4 article 2.3.6.3.3.11 del Decree 1077 of 2015, and the discussion process with the citizens and sector stakeholder continue”

<http://www.cra.gov.co/es/otras-secciones/item-otras-secciones/23205-resoluci> Recovered on 10 de May 2016

## SUSTAINABLE SERVICES

### Finance & Lifecycle Costing

---

# Improving Service Sustainability of Electric Pump Systems in Rural Timor-Leste

---

Type: Long Paper (up to 7,000 words)

### Authors

Jonathan Choksey, Mechanical Engineer, Mott MacDonald, UK, [jonathan.choksey@mottmac.com](mailto:jonathan.choksey@mottmac.com), 0044 (0) 1223 463818, Martinus Nahak, Chief of Department at National Directorate of Water Services, DNSA, Timor-Leste, [martinus.nahak@mop.gov.tl](mailto:martinus.nahak@mop.gov.tl), Rogelio Ocampo, Rural Water Expert, Timor-Leste, [roger.ocampo@gmail.com](mailto:roger.ocampo@gmail.com), Keith Simpson, Principal Engineer, Mott MacDonald, UK, [ksimpsonunep@gmail.com](mailto:ksimpsonunep@gmail.com), 0044 (0) 1223 463500

### Abstract/Summary

There has been significant investment in rural water infrastructure in Timor-Leste; however the sustainability of these services remains a challenge. In 2015 it was estimated that 65.5% population outside of the capital Dili, has access to a partially or fully functioning system. The government National Directorate of Water Services, (DNSA<sup>68</sup>), with support from Water, Sanitation and Hygiene in the Community (locally known as BESIK<sup>69</sup>), recently completed an asset registration exercise. This showed there are 240 pump systems, outside Dili Urban, supplying an estimated 14% (~159,000) of the population. The functionality of the systems was assessed, with 70% functioning (partially or fully), this is independent of the status of the downstream gravity distribution from the main tank to the community tap stands. Through asset registration and previous capital maintenance expenditure (CapManEx) work, DNSA with support from BESIK has an understanding of the work required to restore, upgrade and sustain electric pump systems. Using this experience it is clear that there is a resource gap to service these systems with a high number of non-functional systems (30%) and a lack of technical and financial resources to attend to this. In 2016 there has been an ongoing strategy to train and equip municipal pump technicians to undertake this work. There has also been a significant equipment purchase including spare parts and tools, complimented by discussions around sustainable funding and institution arrangements.

### Introduction

The Democratic Republic of Timor-Leste is a sovereign state in Southeast Asia. The country has a population of 1.167 million people with 79% living in the areas outside of the capital city of Dili (GoTL, 2015). The country has had challenges, with an occupation by Indonesia (1975-99) and subsequent civil unrest in 2006, resulting in the destruction of public infrastructure. There has since been significant investment in rural water infrastructure; however the sustainability of these services remains a challenge. In 2015 it was estimated that 65.5% of the rural population has access to a partially or fully functioning system (DNSA, 2015). In Timor-Leste there is heavy dependence of piped water systems, including gravity and electric pumps, with a limited number of hand pumps and hand dug wells around coastal areas.<sup>70</sup> This is largely due to the geographic nature of the country with a significant number of people living in the hill areas (where hand pump solutions are not practical).

---

<sup>68</sup> DNSA - National Directorate of Water Services, Ministry of Public Works, Transports and Communications

<sup>69</sup> BESIK – Water, Sanitation and Hygiene in the Community (Be'e Saneamento no Igiene iha Komunidade), the programme formally ended in June 2016.

<sup>70</sup> Estimated to be between 60-80%, based on BESIK staff with over 10 years in-country experience

## SUSTAINABLE SERVICES

### Finance & Lifecycle Costing



**Figure 3-40: BESIK pump technician installing a new pump at Rau Moko in Lautem municipality (BESIK, 2015)**

BESIK, an Australian Government aid programme supported DNSA in delivering sustainable access to safe water supply, improved sanitation and hygiene to the rural communities in Timor-Leste (East Timor). The program had a water service technical team which helped the government with the installation of new systems, rehabilitation and maintenance of existing systems in areas outside of urban Dili. This paper will detail the work of BESIK and DNSA with regards to improving the sustainability of motorized pump water systems in Timor-Leste. A mechanized pump system is one which does not require manual operation by a person and runs on electricity (or in the case of ‘Ram’ pumps differential head and flow conversion), and does not include hand pumps. These systems usually deliver to a high level tank which is connected to a piped gravity distribution network with tap stands in the community as shown in Figure 3-41.

Figure 3-40 shows a BESIK technician, on behalf of DNSA, undertaking capital maintenance work (CapManEx) at Rau Moko pump system, which will be the case study in this report. The contents of this paper are predominantly an assessment of work undertaken by the BESIK team and where data is available DNSA work is also documented. This paper deliberately does not discuss the role of the community and women in the day to day management, operation and maintenance of the gravity sections and water points. The paper will focus on the recent asset registration on rural electric pump systems, financial & system management models and work on the capital maintenance of these assets. The activities documented in this paper were part BESIK’s programme and were endorsed by DNSA. (BESIK, 2015c) The activity proposal for this delivery strategy stated that:

*“The initial focus is specifically on the electrical pump element of pumped systems, recognising that there are broad ranges of factors that also contribute to delivery of water in any public water supply system. There is sufficient evidence that the rural electrical pumped systems (electric, generator and solar) are perceived to have very low sustainability due to operational faults that cause total system failure.”* (BESIK, 2015)

The following is a high level summary of the strategy:

1. National pump system asset registration, including an assessment of capital maintenance work completed on pump systems over time.
2. Analysis of Cova Lima and Ainaro pump system operation and maintenance (O&M) trial “Service Provider” contract

## SUSTAINABLE SERVICES

### Finance & Lifecycle Costing

3. Service provider contracts to be improved/streamlined based on the analysis of the two year O&M trial
4. Capital maintenance undertaken by BESIK pump system technician over three years
5. Training a team/s of pump system technicians to build the capacity of DNSA and Timor-Leste to undertake pump system O&M
6. Establishment of government policy and standard operating procedures with respect to the management, technical design and financing of electric pump systems

### Context, aims and activities undertaken

The aim of strategy outlined in the previous section was to establish a programme that looked at increasing the sustainability of pump systems in Timor Leste. When a pump system fails the impact on a community are serious (particularly if spare parts and competent technicians are not available). Where there is no functional improved water source providing water<sup>71</sup> the community members (mainly women and children) will be walking up to 3 hours a day round trip to collect water and are open to health risks from using an unimproved source.

A pump system in this context is defined as the infrastructure installed from the source (bore or spring) to the primary delivery tank. This may include a bore hole, spring collection chamber, pump, associated electrical supply, control panel, sensors (level, temperature or other), distribution manifold (complete with valves and flow meter), rising main and primary storage tank. The electric pump system does not include the gravity connection from the primary tank to the community distribution lines and tap stands. A schematic of this is shown in Figure 3-41.

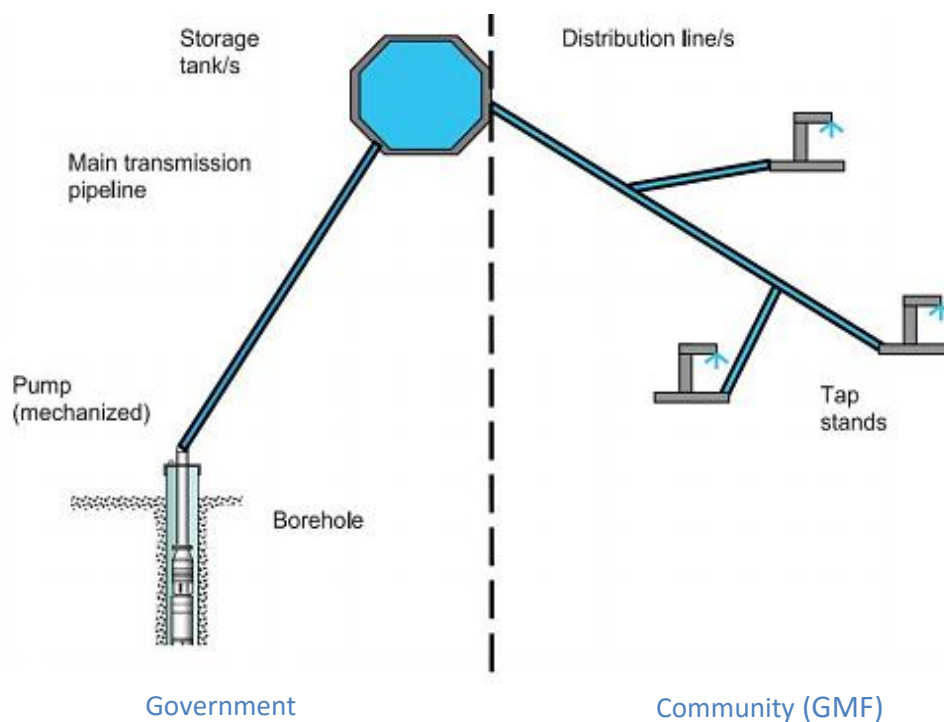

<sup>71</sup> The national standards - 200m distance to a water point

## SUSTAINABLE SERVICES

### Finance & Lifecycle Costing

Figure 3-41: : Management model documented in the GoTL rural water sanitation guidelines (DNSA, 2012)

An example of typical pump systems is shown in Figure 3-42, with centrifugal (submersible and dry installation) powered by generators, electrical grid connection or solar power. This paper will focus on systems of this nature.

The purpose of the strategy is to provide DNSA with an understanding of their assets outside of the capital, Dili, their condition, costs to maintain and the human resources (and support structure) to undertake the work. The activities outlined in the previous strategy section are further detailed below with a summary of the activities undertaken under each main component.



Figure 3-42: Types of pumped water systems in rural areas, large centrifugal pump (left), small centrifugal pump (top right) and solar submersible pump (bottom right) (BESIK, 2015b)

### National pump system asset registration

BESIK completed an asset registration exercise in partnership with two teams (from NGO Triangle (TGH) and training centre CNEFP<sup>72</sup>). The teams collected asset data on the condition of all pump systems and main tanks including urban centres but excluding urban Dili. Prior to the assessment it was assumed that there were approximately 200 pump systems across Timor. The assessment will include the registration of systems which serve communities, schools, government facilities and clinics. The scope and purpose of this exercise are detailed in Table 8 as follows:

- assist DNSA with equipment selection and \$1M counterpart funded<sup>73</sup> “equipment purchases”.

**Table 8: Selection of data parameters collected is as follows (extract of form shown in Appendix A):**

<sup>72</sup> CNEFP – National Centre for Vocational Training

<sup>73</sup> Government money: which is the first budget allocated specifically to rural pumped systems (CapManEx)



## SUSTAINABLE SERVICES

### Finance & Lifecycle Costing

Data class	Details
System beneficiaries	System name, Aldeia or more than one Aldeia (village) served, Suco (local area), administrative post (wider local area), Municipiu (municipality) and population served
System location	location (GPS) and elevation of system components; water source, pump and primary reservoir
Pump details	pump model, rated flow (l/s), head (m) and power (kW), operation (hrs/day), operator details
Pipe and tank details	piped transmission length, collection tank size, no data collected on gravity distribution
Performance	Any local data on performance problems

The outputs of the asset registration will be used to analyse the following:

- A national and municipal map showing where pumped systems are located
- Analysis of the types of system, population served and quantity of water delivered
- Analysis of the current number of systems functioning and not functioning
- Summary of pump brand and model to allow improved visibility of stock requirements and future stock rationalisation
- Summary of school and clinic pumped supplies that can help inform on the status and requirement of important public infrastructure.
- Assist DNSA with implementation of equipment procured under a \$1M counterpart fund<sup>74</sup>
- Analysis of power consumption to assist policy decisions about cost recovery and tariff setting

#### “Service provider” trial contract

A “service provider” contract model provide routine operation and maintenance of electric pumped systems. A service provider trial was completed in July 2015. An evaluation of the contract included the following:

- Preliminary analysis of the common problems and costs for repair – logistics planning / time
- Review possible technologies that can be used to reduce the frequency of break-down – technical improvements
- Assess technicians needs to carry out routine repairs at scale
- Scaling up findings to a national level to get an evidence-based cost of CapManEx that needs to be allowed in the recurrent budget to keep pump systems well maintained

#### Service provider contracts

Based on the findings of the Cova Lima and Ainaro “service provider” contract, a general O&M contract may be developed. Following an assessment of the pump asset registration (detailed in section 0) municipalities which would be appropriate for this type of contract may be selected. The services may be provided by local government (DAA), private sector enterprises or by individual accredited pump technicians. To help this progress a clearer financial model is required, that can be applied to existing data. This will be used to advocate for further scaled up trials of this approach and it is hoped will improve service delivery. A potential institutional structure to facilitate this arrangement is shown in Figure 3-43.

<sup>74</sup> Government money: which is the first budget allocated specifically to rural pumped systems (CapManEx)

SUSTAINABLE SERVICES

Finance & Lifecycle Costing

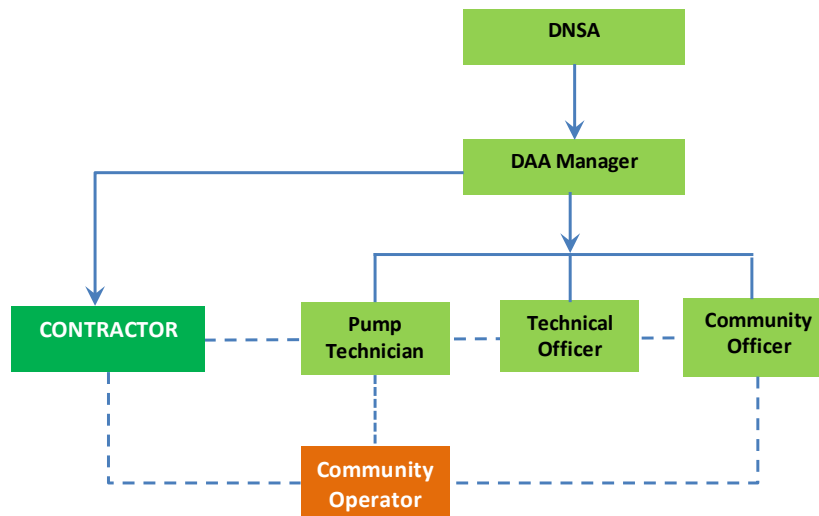

Figure 3-43: Potential delivery model for a municipal level pump O&M “service provider’ model utilizing either a municipal government pump technician or a private sector “service provider”

Capital maintenance – “National model”

From 2012 to 2015 BESIK financed and resourced a pump system technician to undertake the capital rehabilitation of pump systems and commissioning of new systems. The interventions undertaken over this time were recorded using maintenance logs, shown in Appendix B. An example intervention undertaken by BESIK at a site called Rau Moko is shown in Figure 3-40. At this site the pump motor had ‘burned’ due to an electrical voltage surge, and the control panel did not have adequate electrical surge protection to prevent this. The replacement motor was valued at US\$1,200, excluding the time/expenses of a trained technician travelling 120km from Dili to conduct repairs. A more realistic total cost would be US\$1,510, which is \$310 for expenses detailed in Table 10 (Though this can be higher as poor roads can be impassable during the wet season). There are 59 households (hh) in Rau Moko, so this cost would work out at around \$25/hh. The house holds contribute 0.5\$/month for the system operation, including contribution to the management committee.

The maintenance interventions have been characterised by the type of work undertaken, minor (<\$500), medium (\$500<x<\$3000) and major (>\$3000). This is, summarised in Table 9. A minor component has a low cost and is relatively simple to replace or fix on site, for example; miniature circuit breaker (MCB), electrical cable (single or three phase), phase relays, level probe, non-return valve, water meter, ball valve, air release valve. These components range in cost from \$10 to \$100 depending on the size and type of system with an average cost of \$50<sup>75</sup>. A medium example is a ‘standard manifold’ for DN80 and DN50 has; an air release valve, non-return valve, ball valve, water meter, pump steel cable and stainless steel pipe lengths. Borehole rehabilitation is major type and involves the removal of a pump, and insertion of a ‘jetting’ probe with various chemicals depending on the contamination, this is currently subcontracted work to service providers. With regards borehole drilling contractors in Timor-Leste, there is only one Australian certified contractor which can undertake borehole reconditioning. All cost data was gathered from average cost data for new systems or rehabilitation work funded by BESIK.

Table 9: Maintenance intervention examples with estimated cost per intervention (BESIK, 2015)  
 7677

75 An average of \$50 per component was taken to represent components in this category (minor)

76 Observed contamination from Iron Bacteria and Calcium deposits. As refurbishment becomes common practice there is a risk that boreholes become cross-contaminated by substandard drilling practices

77 EDITL – Electrical Department of Timor Leste, GMF – Community Management Group

## SUSTAINABLE SERVICES

### Finance & Lifecycle Costing

Maintenance intervention	Type (Major /Medium/Minor)	Intervention Cost
Minor components (elec/mech)	Minor	\$ 400.00
Solar Pump (Large)	Major	\$ 8,350.00
Solar Pump (Medium)	Major	\$ 7,050.00
Solar Pump (Small)	Major	\$ 3,350.00
Mains Pump (Large)	Major	\$ 8,900.00
Mains Pump (Medium)	Major	\$ 5,550.00
Mains Pump (Small)	Major	\$ 3,350.00
Temporary Pump (Small)	Medium	\$ 700.00
Control Panel (Solar)	Medium	\$ 1,550.00
Control Panel (1 Phase)	Medium	\$ 1,550.00
Control Panel (3 Phase)	Major	\$ 3,350.00
Standard Manifold (DN80)	Medium	\$ 2,535.35
Standard Manifold (DN50)	Medium	\$ 1,585.00
Bore Hole Rehabilitation <sup>8</sup>	Major	\$ 4,350.00
Bore Hole (New)	Major	\$ 15,350.00
Site Survey/Monitoring	Minor	\$ 350.00
Coordination (EDTL/GMF/Other) <sup>9</sup>	Minor	\$ 350.00
System abandoned (new system)	Major	\$ 93,500.00

The cost of the intervention, as with all the costs detailed in Table 9 have an additional \$310 added for the cost of team mobilisation from a national level. The cost of team mobilisation has been taken from the operational data available from BESIK, a brief breakdown is shown in Table 10, which includes; staff salary, fuel, per diem and accommodation.

**Table 10: Pump system repair team resourcing costs - 2 day trip with overnight accommodation**

Cost element	Cost: 2 days 1 night	Day trip from local office	Details/assumptions
Staff salary - Pump technician	\$ 80.00	\$ 40	\$900/month for 2 days
Staff salary - driver	\$ 50.00	\$25	\$550/month for 2 days
Vehicle fuel (+10% vehicle maintenance)	\$ 60.00	\$40	Average of 150 km return trips to sites
Per diem and accommodation (technician and driver)	\$ 120.00	\$40	\$20 per diem and \$20 for accommodation per staff. 2 day trip
<b>Total</b>	<b>\$ 310.00</b>	<b>\$145 (50% saving) if local service provider</b>	

Section 0 will detail the assessment results for the maintenance interventions undertaken by BESIK from November 2012 to November 2015. This will include the number of maintenance visits, type, cost and result of interventions. Further, it will provide details of future work to be undertaken on the locations which were not functioning at the time of the analysis (dated November 2015).

### Training a team/s of pump system technicians

DNSA intends to have a team of pump technicians based at sub-national level that can manage all but the most complex failures, which forms part of a National Pump Operation and Maintenance Programme

## SUSTAINABLE SERVICES

### Finance & Lifecycle Costing

(NPOMP). Training and capacity development is a critical component that includes government staff involvement in the maintenance of pumps and service contract management. DNSA recognise that there is currently a gap in skills and government institutional capacity improvements in all areas are required, (technical/practical, systems, budget, data management, logistics etc.).

DNSA want to be an institution that can respond quickly to faults and support pumps operation and so need to develop their National role of the local role of District Water Authorities (DAA), as one of the programme components. Initially this strategy includes the training of 14 staff to become municipal level technicians to increase the countries capacity to operate and maintain electrical pumps. An overview of the training course developed it shown in Table 3, the course includes a 3 week classroom and workshop based training followed by a month in the field training supported by experienced technicians. Finally an additional 3- 6 month follow up review and skills assessment leading to accreditation<sup>78</sup> and possible employment for successful graduates.

The course has been created in relation to a competency matrix and training curriculum developed by the BESIK team with support from Mott MacDonald, which is shown in Appendix E.

### Policy and system management models

Management of the systems alongside the asset registration exercise is central to the sustainability of pumped water systems. The rural water supply guidelines stipulate that for pumped water systems the pump and transmission line up to and including the main water collection tank are the responsibility of the service authority (in this case DNSA). Further that, from the point of connection at the collection tank outlet to the system tap stands in the Aldeia/s is the responsibility of the community (this model is shown in Figure 3-41 but is considered a simplification of the wide range of system layouts, size and complexity and is not applicable as shown everywhere). There are significant financial and technical challenges for maintaining pump systems due to their complex nature, which is the main driver behind this split responsibility model. Many piped systems serve over 1000 beneficiaries and are designed to provide water within 200m. This system, as will be discussed in section 0, can be expensive to maintain. (DNSA, 2012)

In section 0 pump system management tools have been proposed that are part of the wider strategy to increase the capacity of the government to fulfil their manadated responsibilities. This work is in parallel to increasing the capacity of the existing government water technical services team (DAA) with the training and funding of new technicians, detailed in section 0.

## Main results and lessons

### National pump system asset registration

From the asset registration the following assessment has been made; there are 240 rural pump systems supplying an estimated 14% (~159,000) of the population and 70% (June 2015) of the pump systems are currently functioning (partially or fully). Figure 3-44 shows a representation (by location in Google Earth) of how the systems are clustered around centres of population mostly along the coast alluvial plain and inland limestone areas. This also includes details of the type of system: electrical grid (borehole), electrical grid (spring), solar (borehole), generator (borehole) and generator (spring). There are 170 boreholes and 70 spring sytems (spring gravity intakes to a collection tank with a pump inside) in the rural areas that have electric pump systems. The boreholes have a depth range of 5m to 40m and deliver flows from 0.3 l/s to 60 l/s. There are 169 community systems, 26 schools, 5 medical clinics and 31 other public facilities. The immediate results show much high rates of fucntionality that initially assumed in the

<sup>78</sup> The process of accrediting the course has been started with the IMO and government ministries

## SUSTAINABLE SERVICES

### Finance & Lifecycle Costing

strategy documentation which stated that “rural electrical pumped systems...have a very low sustainability”. (BESIK, 2015c)

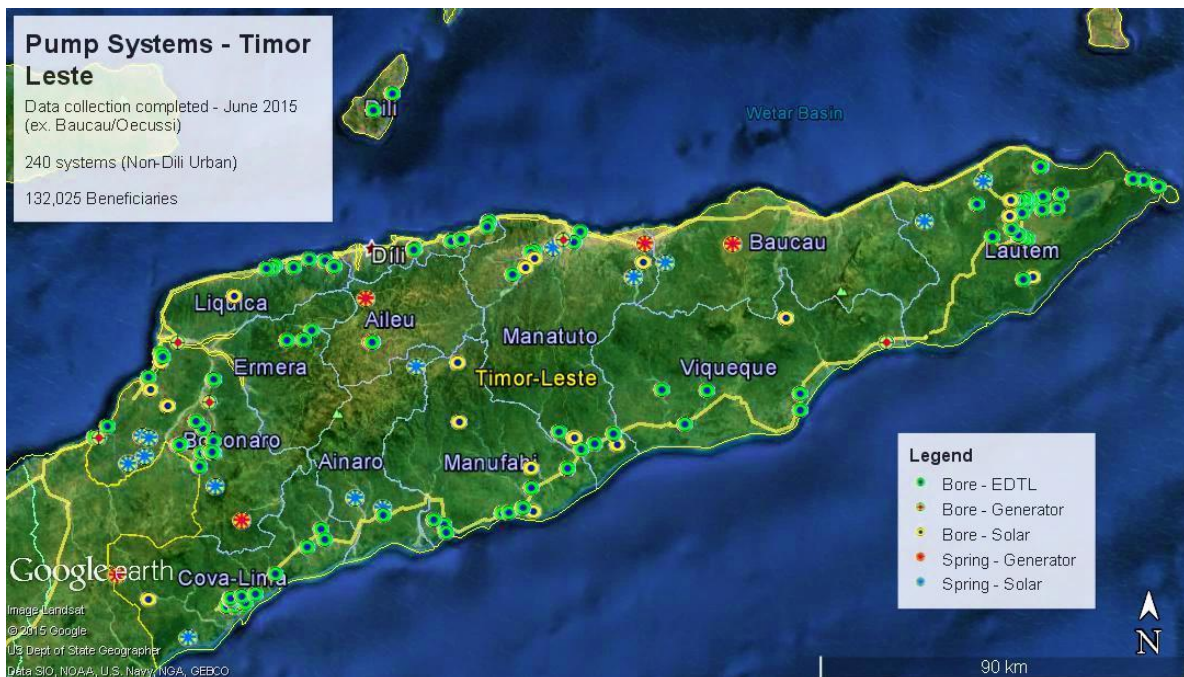

**Figure 3-44: Google Earth representation of the location and types of pumped water systems in rural areas, the colour coding on the system ‘dots’ denotes the type of system and energy supply (solar/EDTL). (BESIK, 2015)**

The data in Figure 3-45 shows that there are predominantly electrical grid connected systems (64%), with a fewer number of solar systems (25%) and generator systems (7%). There are also a small number of mechanical Ram pumps. Further that the systems connected to the electrical grid connection or generator have 68% and 65% functionality, compared to solar systems at 80%. However there are significantly more electrical grid systems in the country so it would not be possible to conclude that solar systems are more reliable.

The analysis in this section does not include the full details for Baucau Municipality of Oecussi. At the time of analysis these data sets were not available. Summary details for the number of systems and limited technical information was available and included for these areas.

SUSTAINABLE SERVICES

Finance & Lifecycle Costing

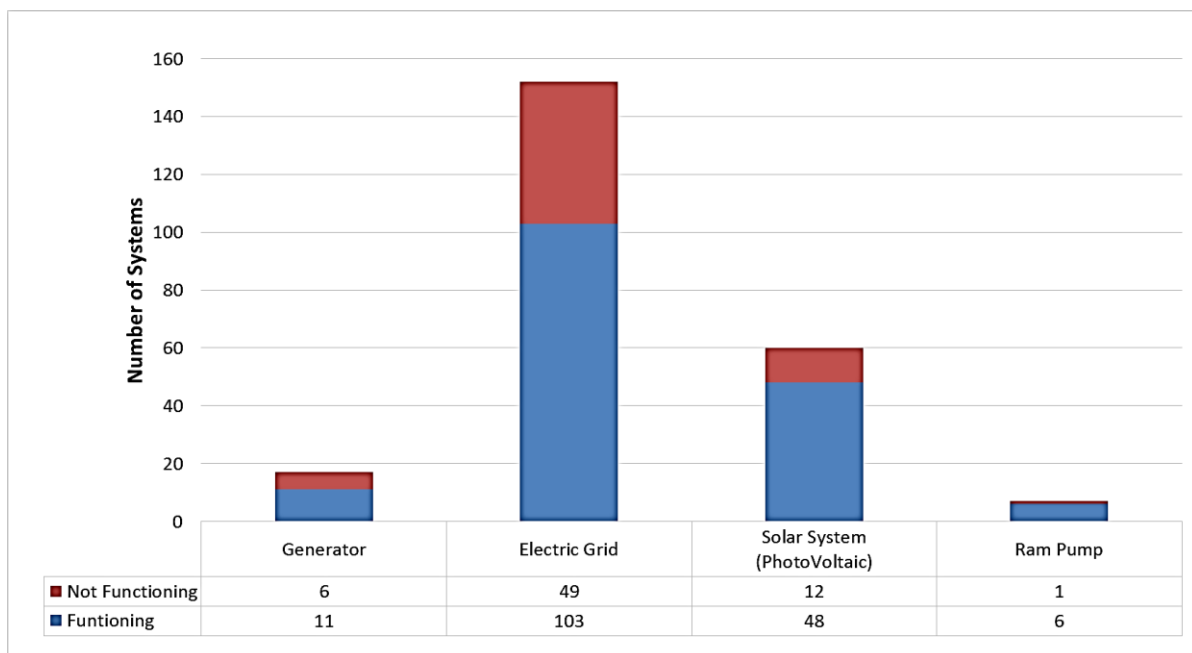
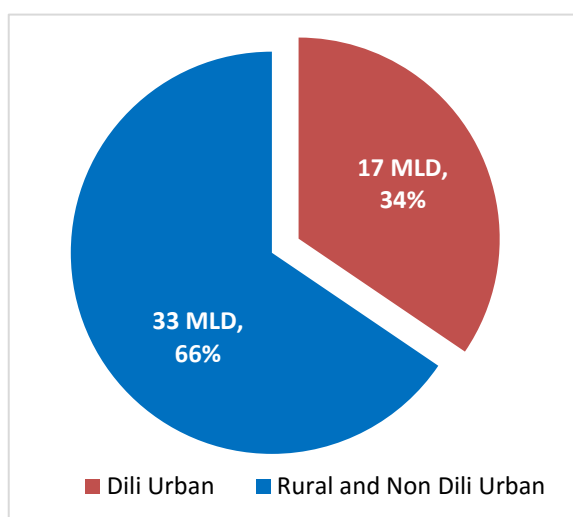

Figure 3-45: Summary of results from asset registration on pump systems in Timor-Leste, June 2015 (BESIK, 2015)

From 2010 to 2015 as with the expansion of the electrical grid network to the majority of rural areas prevalence of electrical grid connected systems has increased. This also includes modifying previously solar systems to electrical grid systems, as in the case of Oebaba in Suai municipality, though the reasons and benefits of this practice are unclear. Previous to the drive to connect systems to the electrical grid the systems in these areas were powered by generators and solar with a limited number on non-electric ‘Ram’ pumps. An analysis of the 26 known pump systems in Dili urban areas was completed to compare the production and population served between this and the areas outside of the capital city.



## SUSTAINABLE SERVICES

### Finance & Lifecycle Costing

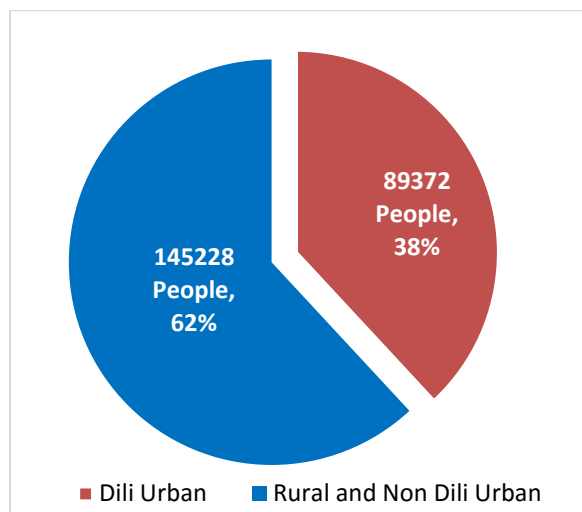

Figure 3-46: MLD supplied by pumped systems (left), population served by pump systems (right) (BESIK, 2015b)

Figure 3-46 shows that the pumped systems outside of the capital Dili, provide over 33 MLD<sup>79</sup> to around 159,000 people and the systems in Dili Urban 17.5 MLD ( to around 89,000 people. The population estimates have been calculated using an average house hold size of 5.5 from the 2015 population census data. It is noted that the ADB used a house hold size of 7.7 in Dili urban for the 2015 Dili Urban Water Supply Masterplan, therefore the figure of 5.5 used is deemed to be conservative. (ADB, 2015).

### Pump system power consumption

The asset data includes details which may be used to calculate an estimated power (kW) consumption of a system. This is done by taking the pump system flow (l/s) and calculating the total hydraulic head (m)<sup>80</sup>, which is then compared or mapped onto the manufacturers pump curves. From the curves the pump hydraulic efficiency, motor efficiency at the ‘duty point’ and power (kW) consumed by the motor are taken. An example power calculation for Rau Moko has been included in **Error! Reference source not found.** – Appendix C, an extract of which is shown in Table 11. This shows that the system is estimated to consume 2169.35 kW annually at a cost of \$260.32 to operate this. Currently the energy costs for pump system operation (for the systems assessed) are not charged to the communities or paid for by DNSA, they remain a debt to EDTL. Though an interview with a DAA manager in Ainaro municipality claimed there was an allocation funds to pay the electricity of a pump system, however EDTL manager could not confirm.

However, tariff policy is being developed (which includes cross subsidies for vulnerable households) and if legislation was passed that the system operational costs should be covered by the communities there would be significant financial burden. Rau Moko has 59 households, contributing \$0.50 / month to the community management group which is a total of \$354.00/annum. Therefore 74% of the money collected would be spent on electricity costs (\$4.50), which leaves only \$93.68 for operator contribution and spare parts.

Table 11: Pump system annual power and cost calculation for Rau Moko system, see Appendix C for full calculation

<sup>79</sup> MLD – Mega litres of water per day

<sup>80</sup> Hydraulic head – is a measure of the liquid pressure required to deliver the flow and is calculated from the following terms; flow rate (l/s), elevation change (static hydraulic head), pipe ‘roughness’, fittings (e.g. valves & bends), pipeline diameter and length.

## SUSTAINABLE SERVICES

### Finance & Lifecycle Costing

Nominal Flow (l/s)	Calculated Static Head (m)	Calculated Dynamic Head (m)	Calculated Total Head (m)	Motor Power (kW)	Operating hours	Daily Energy (kWh)	Annual Energy (kW)	Cost (\$) / kW	Annual Cost(\$)
1.20	108.00	4.80	112.80	0.74	8.0	5.94	2169.35	\$ 0.12	\$ 260.32

A further analysis of all the pump systems has been completed, in the absence of complete asset information, the pump maintenance records have been analysed and appropriate estimations used. Where there is not enough information to complete the analysis with a reliable estimation, these systems have not been included in the analysis. An example of a large system is Leopa in Liquiçá Urban area, which has a Grundfos SP17-13 which has a duty of 30 l/s at 133m total head. The estimated yearly energy consumption of this system is 41,500 kW which equates to \$4,987 (at \$0.12/kW). It is estimated that for the 95 systems which data is available that this totals to \$135,000. The house holds served per system varied from a minimum of 5 to a maximum of 1700 and average of 200.

However this \$ 0.12 per kW value used is the subsidised government tariff, the true cost of every production is “*estimated to be between \$ 0.27 and 0.40 per kW*”. (Nerini, 2014) Using the true energy production cost for Rau Moko, it gives a total cost of between \$ 586 - \$ 861 per annum. For a large site such as Leopa mentioned above the actual cost of supply is between \$ 11,220 and \$ 16,623 per annum. Lastly applying the same analysis for the 95 sites with sufficient system information for an energy calculation we reach a total between \$ 303,750 and \$ 450,000. (the analysis is ongoing as further systems are analysed in more detail)

This analysis will allow policy discussions to start within the Ministry of Public Works, Transports and Communications of Timor-Leste on the required GoTL budget expenditure and subsidy and tariff setting in the rural context with actual data on power consumption in rural areas, power usage and national level agreement on the approach to power supply to rural pump systems.

### “Service provider” trial contract in Covalima & Ainaro municipalities

As described in section 0, private contractor was selected as the service provider for BESIK’s first O&M pump system trial (Figure 3-47 shows the team and a sample location). They were allocated 16 sites in Covalima and Ainaro municipalities, of which 12 of the sites were operational at the start of the trial. The project duration was 2 years. The team were initially contracted to visit each location 2 times a month and attend any emergency call outs. An evaluation was conducted by BESIK team and local community and government representatives on the effectiveness of this scheme. The outcome of the evaluation is detailed below.



Figure 3-47: Service provider 'Taroman' team and community water tank from Oebaba village a contract site (BESIK, 2015)

Of the 12 systems which were functional under the contract, all 6 sites visited during the assessment have functional pumps; therefore it is assumed that a high percentage of the other sites are functional. There were 13 minor emergency call outs (electrical components) with an average system down time of 3 days



## SUSTAINABLE SERVICES

### Finance & Lifecycle Costing

and 1 major emergency (pump failure). This took 6 months to resolve the warranty dispute and subsequent delivery of new pump from a supplier in Dili. The communities described the benefits from the pumped water supply – improved water access, less burden for the women; increase school attendance and improved hygiene.

In reference to the service provider’s compliance to contract terms, the contractor reported a total of 369 site visits. However during assessment we learned that the actual number of site visits performed was around 120. Furthermore the contract was priced on the use of a car for all maintenance site visits, during the assessment it was found that after the first two months a motorbike was predominantly used, therefore reducing the fuel bill.

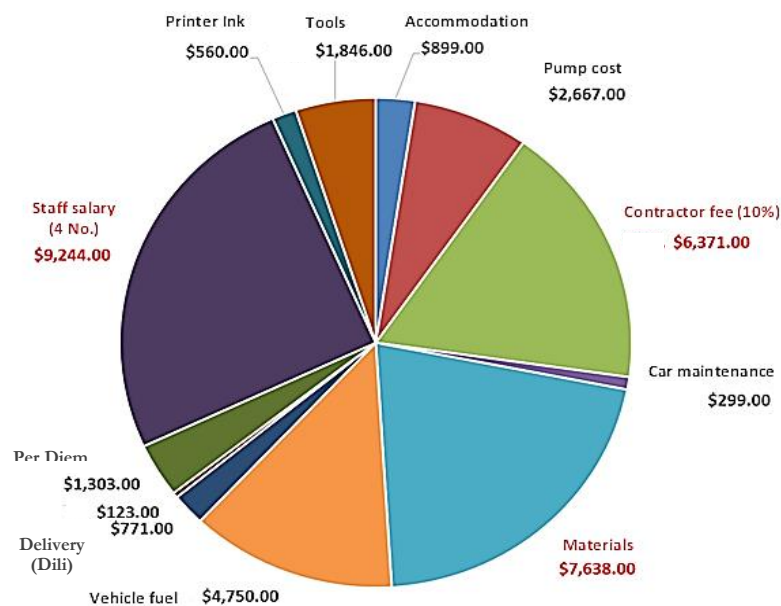

**Figure 3-48: Cost model for future provision of services based on assessment**

The service provider contract value was \$73,485, which for the 12 operational systems is annually around \$4500/pump system. An adjusted contract value based on the assessment is detailed as a cost breakdown in Figure 3-48. This gives an estimated annual cost of delivering these services of \$37,720, which for 12 operational systems is annually around \$2300/pump system. These systems served 1,810 households which gives a cost of \$21/HH per annum. From this trial private sector service provider there has been clear benefit to the technical sustainability of the systems with all but one of the 12 systems functioning during the programme. However there are lessons in terms of contract financial management. From this programme and other initiatives with gravity piped systems the government in considering more private sector partnerships as shown in Figure 3-49.

## SUSTAINABLE SERVICES

### Finance & Lifecycle Costing

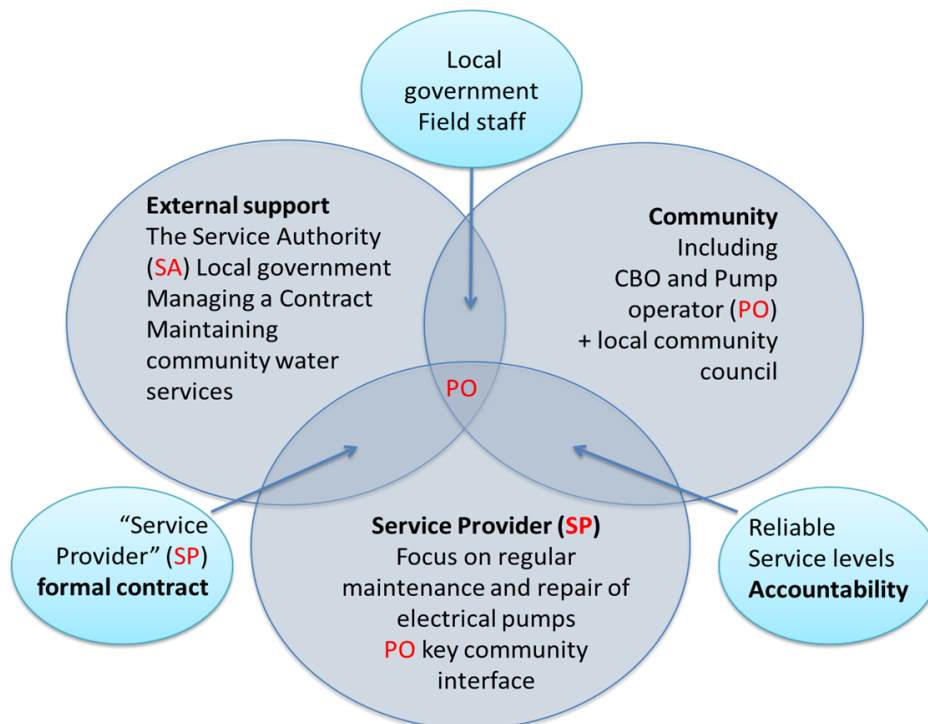

Figure 3-49: Rural Water “service delivery” model (BESIK 2015b)

Several recommendations were made from this assessment to inform any future service delivery contracts.

The key ones are detailed below:

- Improve Coordination with partners (service providers and municipal government offices and suppliers) and formal introduction to the communities to build trust and deliver efficient service
- Team size of 3-4 including a manager, 1 pump technician and two support staff;
- Regular pump maintenance to be done once every three months per site not every two weeks;
- Regular independent monitoring and surveys by DNSA to ensure quality and accountability; Allowing the development of Key performance indicators (KPI) to show improvement over time and allow multi-year <sup>81</sup>contracts to be awarded.
- Develop clear communication paths and records of communication at all interfaces – SA – SP; SP to Community; Community to SA

### Capital maintenance – “National model”

During the BESIK team capital maintenance from November 2012 to November 2015 a total of 134 site visits were undertaken to 73 different sites (example shown in Figure 3-40). Of these there were 46 surveys undertaken to assess the requirements for upgrading the components with standards parts (adequate electrical protection, discharge manifold with all valves, flow meter and a secure fence around the asset). There were 27 site surveys to assess the issues with a site reported as non-functional which could not be fixed during the same visit and subsequent visits were undertaken. Of the 134 site visits 54% resulted in a system being made functional again (permanent or temporary).

The remaining 46% were either not fixed (non-functional) or fixed on a later visit, with a total of 64 site visits reported as non-functional after a given site visit. To summarise this it can be stated that there were

<sup>81</sup> DNSA are tied to an annual budget cycle at this point – Service provider contracts would benefit from being over more than one year.

## SUSTAINABLE SERVICES

### Finance & Lifecycle Costing

a number of site visits, 25 sites were visited more than once, and a small number of sites (for example Manu Aman) became non-functional more than once in this time period. Figure 3-50 shows a summary of the site visits undertaken and the outcome of this work.

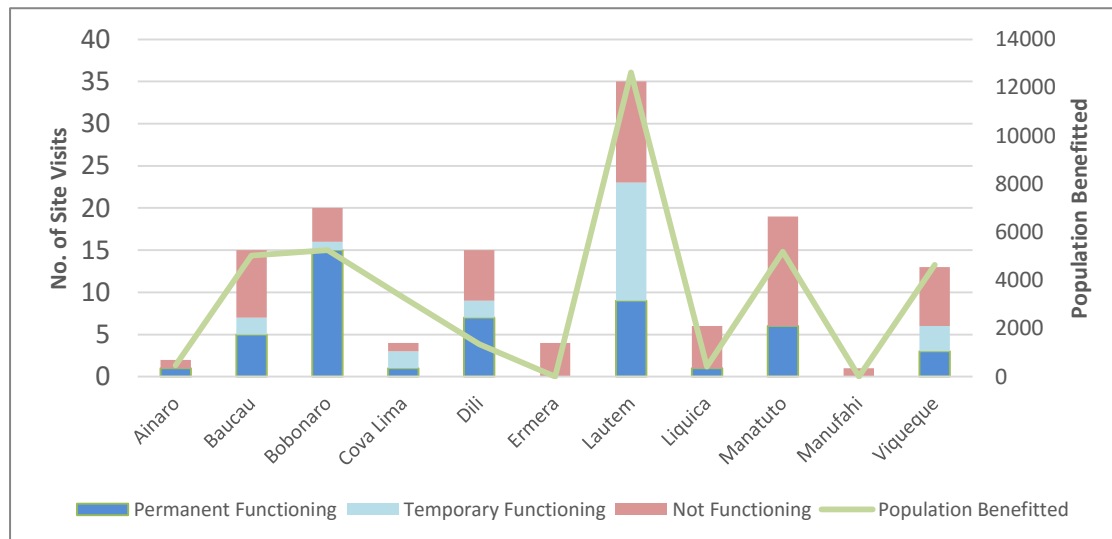

**Figure 3-50: Summary of site visits per municipality, the outcome of each visit and the population benefitted by the interventions.**

The site visits have been mapped against the asset registration for the number of beneficiaries per system fixed as shown as a per municipality summary in Figure 3-50. The total number of people with access to an improved water supply from these maintenance interventions is estimated at 38,200, which is 24% of the people served by pump systems outside of Dili Urban. An analysis of the types of interventions, as shown in Table 12, gives an insight into the what work was carried out and the main components which developed faults.

From the 139 site visits, 427 separate actions were recorded and where it was possible these actions were undertaken, the others were recorded for action at a later date. Of these there were; 28% pump faults, 41% control panel faults, 9% incomplete discharge manifolds (not all components present e.g. non return valve, gate valve, air release valve and water meter), and the remaining 22% other unique faults or site surveying.

**Table 12: Extract from maintenance records of components with problems, the problem and a description of the action taken (BESIK, 2015b)**

Component	Problem	Action
Pump	Broken	Install temporary pump
Pump	Broken, not yet tested	Lift up but wait for electricity (because no electricity when location visited)
Pump	Broken	Change pump (Grundfos SP5A) and conduct pumping test
Control Panel	Burnt components	Change PS1800 Lorentz control panel
Control Panel	EDTL not yet connected the control panel	Coordinate with contractor/EDTL and assist in installation
Control Panel	Overload	Reset voltage and the phase rotation
Manifold	Gate valve closed	Advise the community to check the system is in good condition before operating system
Manifold	Mud in water meter	Open water meter and clean
Manifold	Only gate valve	Installed a new manifold complete with GV, NRV, air valve and water meter

## SUSTAINABLE SERVICES

### Finance & Lifecycle Costing

As part of the maintenance interventions analysis, all actions were assigned a cost based on the data compiled in Table 9. This approach was adopted to provide an evidence based estimate of the cost of delivering the O&M programme over that time period. A summary of the type, cost estimate and number of each category of interventions is shown in Table 13, which also includes the projected future costs of incomplete interventions. It can be seen that 174 actions were taken; the remaining actions noted in the data were not completed on the site visits they are logged on.

The cost of completed actions is estimated to be \$103,100 over the 73 sites giving an average of \$1,410 per system over three years and therefore an annual of \$470. A further analysis of the work not completed is also shown in Table 13. The future projected work is based on the maintenance record recommendations to make all sites fully functional and upgraded with standard components. These results show that an estimate 139 further interventions are required for the 73 sites visited at an estimated cost of \$328,155. The costs are much greater for the future planned work as they include upgrading sites with standard manifolds replacing temporary pumps with permanent pumps and control panels, as well as 7 new boreholes for systems which have been abandoned and the bore unusable.

If the systems are upgrade as per national standards, which are under development, then the rate of system failure should decrease. Furthermore the type of failure will be minor (easy/low cost fixes); the current situation still requires significant investment to bring all the systems back to full and sustained service levels.

A high level summary of this work is shown below in Table 14

Table 13: Summary of capital maintenance costs for interventions completed by BESIK from June 2012 – July 2015

O&M Service	Type (Major /Medium/ Minor)	Intervention Cost	Work Completed		Future Work (Est.)	
			Spend	No. O&M Services	Spend	No. O&M Services
Minor components (electrical/mechanical)	Minor	\$ 400.00	\$22,800.00	57	\$ 15,200.00	38
Solar Pump (Large)	Major	\$ 8,350.00	\$ -	0	\$ -	0
Solar Pump (Medium)	Major	\$ 7,050.00	\$7,050.00	1	\$ -	0
Solar Pump (Small)	Major	\$ 3,350.00	\$3,350.00	1	\$ 3,350.00	1
Mains Pump (Large)	Major	\$ 8,900.00	\$ -	0	\$ -	0
Mains Pump (Medium)	Major	\$ 5,550.00	\$11,100.00	2	\$44,400.00	8
Mains Pump (Small)	Major	\$ 3,350.00	\$10,050.00	3	\$56,950.00	17
Temporary Pump (Small)	Medium	\$ 700.00	\$13,300.00	19	\$ -	0
Control Panel (Solar)	Medium	\$ 1,550.00	\$4,650.00	3	\$ 3,100.00	2
Control Panel (1 Phase)	Medium	\$ 1,550.00	\$ -	0	\$23,250.00	15
Control Panel (3 Phase)	Major	\$ 3,350.00	\$ -	0	\$ 10,050.00	3
Standard Manifold (DN80)	Medium	\$ 2,535.35	\$ -	0	\$ 7,606.05	3
Standard Manifold (DN50)	Medium	\$ 1,585.00	\$ -	0	\$47,550.00	30
Bore Hole Rehabilitation	Major	\$ 4,350.00	\$ -	0	\$ 4,350.00	1
Bore Hole (New)	Major	\$ 15,350.00	\$ -	0	\$ 107,450.00	7
Site Survey/Monitoring	Minor	\$ 350.00	\$28,700.00	82	\$ 2,100.00	6
Coordination (EDTL/GMF/Other)	Minor	\$ 350.00	\$2,100.00	6	\$ 2,800.00	8
			<b>\$103,100.00</b>	<b>174</b>	<b>\$ 328,156.05</b>	<b>139</b>

## SUSTAINABLE SERVICES

### Finance & Lifecycle Costing

**Table 14: Summary of outcome, including the number of programme beneficiaries and the estimated future work and beneficiaries (BESIK, 2015b)**

Period	BESIK Work	Future Work
	Nov 2012 - Nov 2015	2016 - 2017
Number of Actions	174	139
Different locations <sup>82</sup>	73	73
Permanent Functioning	48	73
Temporary Functioning	24	0
Not Functioning	62	0
Beneficiaries of fixed systems (permanent or temporary functioning)	38245	37060 <sup>83</sup>
Total cost	\$ 103,100.00	\$ 328,155
Av. Cost / intervention	\$ 590	\$ 4,495
Av. Cost / House hold	\$ 14	\$ 48

To document this process a maintenance form was developed (see Appendix B) and improved over extensive site visits and in partnership with the BESIK pump technician. It has been designed for utility, information gathering and outcome reporting. Other standard forms developed were as follows:

- System construction inspection;
- System rehabilitation;
- Borehole level monitoring with metrics on sustainable yield
- Pump system failure logs to record incoming request for support

The work analysed in this section was conducted by BESIK, it is acknowledged that DNSA also conducted work in Dili Urban and in the areas outside. However data was not available to include in this paper.

### Reducing faults through standard design

From an high level analysis of the types of failure modes recorded from the capital interventions analysed above, it is clear that that there are a number of broad categories of faults:

**Table 15: Categorization of common pump system faults, causes and methods of prevention**

<sup>82</sup> There were 73 sites visited. Some sites broke down multiple times and were visited on several occasions which are why the functionality numbers sum to more than 73 sites.

<sup>83</sup> This beneficiary figure is different to the historic BESIK work as these are the beneficiaries of systems which were not functioning at the completion of previous work and will benefit from future work.

SUSTAINABLE SERVICES

Finance & Lifecycle Costing

System area	Fault	Causes	Prevention
Electrical (control panel & pump motor)	<ul style="list-style-type: none"> <li>- Pump motor 'burns'</li> <li>- Electrical components in control panel 'burn'</li> <li>- Pump stops running</li> </ul>	<ul style="list-style-type: none"> <li>- voltage fluctuations from grid</li> <li>- electrical phase loss<sup>16</sup> causing circuit breakers to trip</li> <li>- inadequate electrical protection in the control panel a pump motor 'burning'</li> </ul>	<ul style="list-style-type: none"> <li>- Install voltage surge protection</li> <li>- Install circuit breakers (MCBs)</li> <li>- Contact EDTL to fix root cause of fluctuation/phase loss</li> </ul>
Mechanical (manifold; valves and pipes)	<ul style="list-style-type: none"> <li>- Pump 'on' but no water delivered to reservoir</li> </ul>	air locks in distribution lines stopping the pump from delivering water, caused by a lack of an air release valve on the discharge manifold	<ul style="list-style-type: none"> <li>- Install 'standard manifold' parts; air valve, non-return valve, ball valve and water meter</li> </ul>
Mechanical (pumps)	<ul style="list-style-type: none"> <li>- Pump flow rate reduction</li> </ul>	build-up of iron oxide/calcium or other contaminants reducing the pump efficiency and affecting water quality	<ul style="list-style-type: none"> <li>- Rehabilitate bore to remove contaminants</li> <li>- Recondition the pump</li> </ul>
Mechanical (operation)	<ul style="list-style-type: none"> <li>- Limited flow from pump or</li> <li>- Pump 'burn out' from dry running</li> </ul>	source depletion or incorrect operation of pump with respect to water levels (may be due to lack of level sensors or faults with sensors)	<ul style="list-style-type: none"> <li>- Install level sensors to prevent dry running</li> <li>- Assess the sustainable yield at different times of year and instruct the operation</li> </ul>

A number of electrical and mechanical faults can be mitigated against with improved design. For electrical design a minimum specification document and associated electrical wiring and line diagram are under development (extract shown in Appendix G). Furthermore the mechanical standard design is being formalised with standard drawings refined and a minimum specification developed. An example of a standard pump system mechanical design is shown in Figure 3-51.

However some of the issues outlined in Table 15 cannot be prevented by improved design, such as the build-up of contaminants (example shown in Appendix D page 36) or improper operation of the systems. For these the summary table suggest methods by which these may be prevented or systems reconditioned.

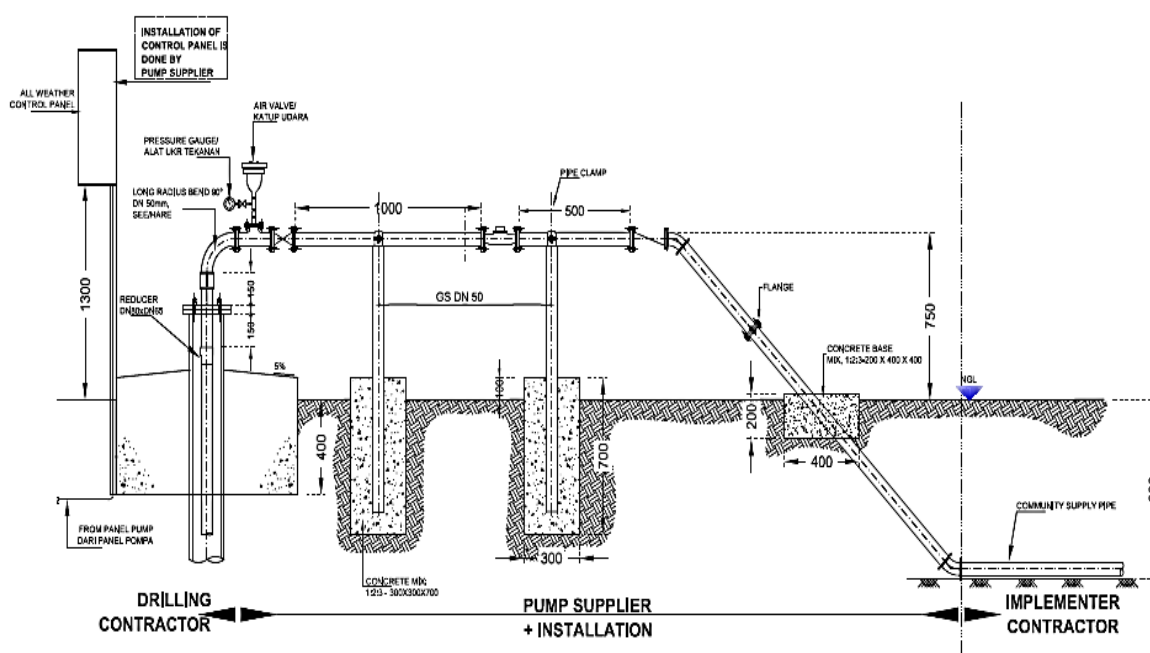

## SUSTAINABLE SERVICES

### Finance & Lifecycle Costing

#### Figure 3-51: Pump system mechanical design complete with; air valve, non-return valve, water meter and ball valve

Lastly it is important to note that a number of electrical faults arose from faults (41% of pump system faults were electrical) some of which are from the incoming power supply (grid connection) e.g. voltage surges or phase drop-out. A broader solution should be looked into by better integration between DNSA and EDTL to communicate supply issues such that they are removed entirely.

#### Training a team/s of pump system technicians

As can be seen from the analysis above the current resources working on the O&M of rural systems cannot keep up with the work required to fix known non-functional systems and attend new failures as they arise. Therefore DNSA supported by BESIK implemented a training programme for new technicians in April 2016. This programme also look into procuring material resources and human resources (spare parts, vehicle access, per diem and salaries) for the servicing the systems outside the Dili Urban area.

As detailed in section 0, the training scheme included a three week intensive introduction to pump systems, mechanical & electrical components, common failure mechanisms, monitoring, system rehabilitation and a 3 – 6 month field experience period. In total 15 trainees attended the training course and on completion of the full course will be assessed as to their suitability to the role. The government may then proceed to select a number of the successful technicians to work for DNSA in Dili or municipal offices. An extract of the teaching materials developed in partnership with Mott MacDonald Limited for the modules is shown in Appendix D.



Figure 3-52: Pump system technician training programme, note high level of field exposure. April 2016

## SUSTAINABLE SERVICES

### Finance & Lifecycle Costing

The training scheme was designed and delivered for a budget of around \$87,000 (budget extract shown in Appendix H) which includes technical support services to the trainees during their 2-month field work assignments. The training included classroom sessions with hands-on exercises and on-the-job training at 3 municipalities with pump mentors. Exams were provided at the end of each training module, and one final exam was conducted at the end of this training.

The pump training was conducted on 12 April to 31 May 2016 at the training centre, CNEFP. After the practical exam/ screening, 15 trainees were selected from 26 candidates from the 12 municipalities to attend the training, and all of them got previous training and exposure in basic electricity. In total, 14 candidates<sup>84</sup> successfully completed the training (classroom training, field exposure and on-the job training) and received the training certificate on the 3rd of June 2016. One of the successful trainees is from DNSA Logistics/ Support Services and he will be joining the DNSA’s pump repair team for urban pump systems.



**Figure 3-53: Field training in Covalima, Bobonaro and Lautem districts, note the female trainee immersed in the exercise in the for ground (top right, second from the right)**

A review of the training delivery has been undertaken and the following key lessons learnt for a future training scheme:

---

<sup>84</sup> One trainee dropped out during the field training due to employment purposes



## SUSTAINABLE SERVICES

### Finance & Lifecycle Costing

- Structure training with smaller groups of 2-3 trainees undertaking practical learning.
- Simulate pump system issues to teach the trained troubleshooting skills and issue resolution
- Use of standard forms and processes must be taught in the class room and then reinforced with continuous use in the field;
- The training duration is thought to be sufficient to acquire the basic knowledge in pump system repair but requires follow up training and further mentor support for 3-6 month field work;
- Grundfos and Lorentz modules should be tailored fit to local technicians giving more emphasis on basic pump features and resolving common pump problems.

#### Financial and management models

The results of financial and community management analysis show that the community pays a monthly tariff for the use of the water. This is between \$0.50 and \$1.00 per household (HH), but can be more than this in a few areas. A sum of US\$0.50 per month is used as a conservative figure, therefore for an average sized community of 100 households this equates to US\$50 per month and US\$600 per year (if 100% collection rate assumed<sup>85</sup>). This amount covers many things including the operator's compensation and the cost of replacement pipes, fittings and tap stands.

Rau Moko, the site shown in Figure 3-40, has had two repairs in 3 years totalling around US\$4,500 expenditure. There are 63 households in Rau Moko giving a potential total community contribution over three years of \$1,701 (\$0.75/HH). Without deduction the operator compensation the total contributions is only 38% of the required amount. Therefore it is not realistic to expect the community to pay for these costs. Furthermore the community does not have the mechanical or electrical skills available, access to spare parts, knowledge of fault finding to attend to a complex breakdown. Therefore the management model described in Figure 3-41 demonstrates one way in which the government can provide the external support that rural communities need if their water system is to be maintained and provide reliable water services.<sup>86</sup>

Once the financial sustainability of the systems is better understood it is possible to use the asset data to scale up the financial analysis, first looking at the work to fix non-functional systems. As shown in Figure 3-54, the status and location of systems are shown with an indication of how teams may manage clusters of pump systems. This type of tool and graphical data presentation also aims to quickly visualise the current status of the pump systems. However for this tool<sup>87</sup> to be useful in the long term there needs to be commitment by technicians and data analysis staff to continuously update it and for managers to use it proactively for planning and procurement purposes.

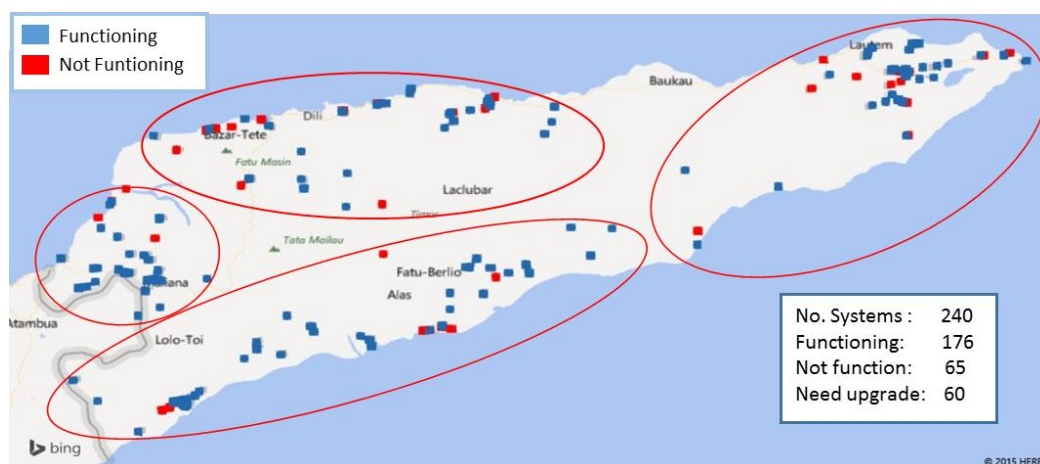

<sup>85</sup> Household collection rate is estimated as 40% - data is being collected on this.

<sup>86</sup> The existing decree law 04/2004 does allow for provision of technical and financial if deemed necessary. It is not currently mandated.

<sup>87</sup> For the tool to become valued at national and municipal there needs to be appropriate budget support and training to allow people to carry out their mandated work and accountability if they do not.

SUSTAINABLE SERVICES

Finance & Lifecycle Costing

Figure 3-54: Maintenance planning tool - map visualization of non- functioning pumps (not including Dili Urban). (BESIK, 2015)

An expanded version of the mapping technique is shown in Appendix F in which key municipality metrics (functionality and population served) are shown alongside a list of key details for each pump system.

Another important part of the financial and management model is a clear structure and process for reacting to a system failure, a proposed strategy is shown in Figure 3-55. This strategy assigns level of authority and severity/type of fault which can be actioned through different mechanism e.g. EDTL for electrical supply or municipal pump technician for major/minor faults. The notes in the figure are detailed in Appendix D and provide specific actions associated to each ‘node’ in the strategy.

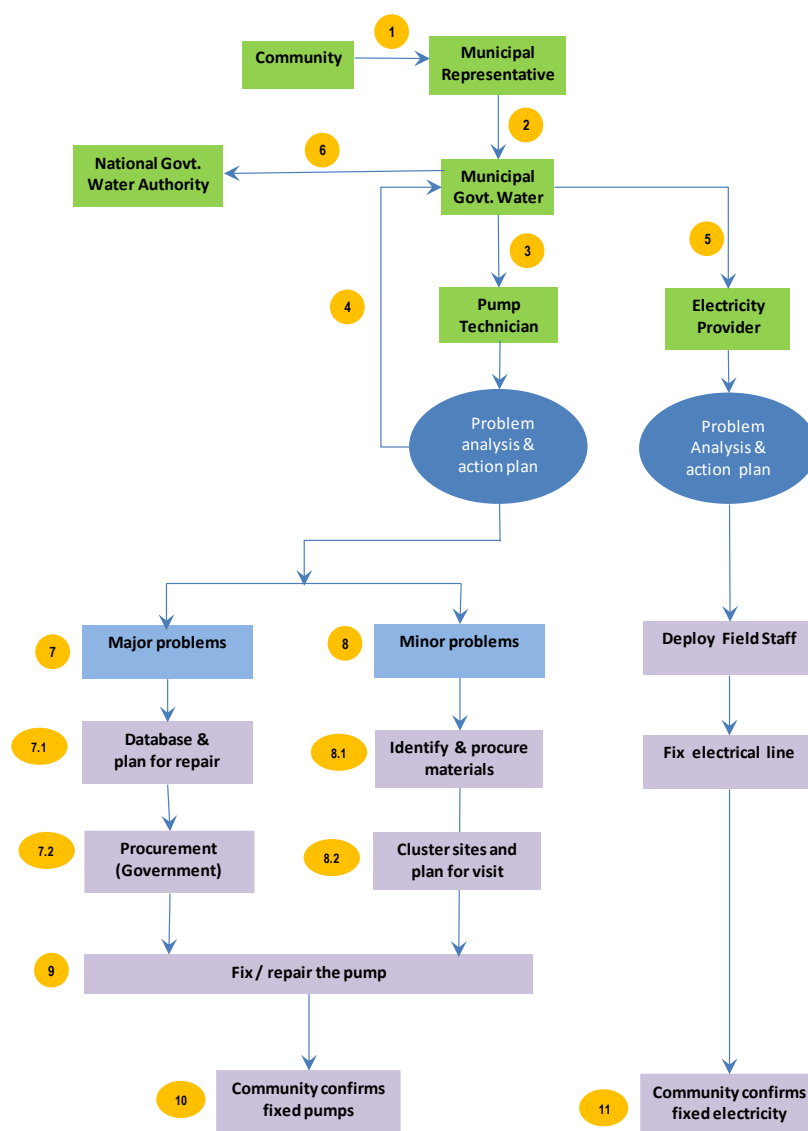

Figure 3-55: Proposed process for pump repairs numbers relate to functional descriptions detailed in Appendix D

It is clear from the analysis that communities need external support in order for rural water service provision to be maintained and provide reliable improved water supplies. Now that the communities have a system which they are unable to financially support, the government may have to subsidise the servicing and monitoring the system functionality. The extent to which subsidy and technical assistance is provided

## SUSTAINABLE SERVICES

### Finance & Lifecycle Costing

is still to be determined, but there is an understanding that their role in supporting water supply that currently focuses on urban areas must extend to the rural areas as well.

### Conclusions and Recommendations

Through asset registration and previous CapManEx work, DNSA now has data, analysis and evidence through which it can gain an understanding of the work required to restore, upgrade and sustain electric pumped systems. Using this data it is clear that there is a resource gap, a high number of non-functional systems (30%) and a lack of technical and financial resources to improve this situation. There is now a greater understanding of where the systems are located, the water delivered, the populations served and growing evidence of where problems occur repeatedly and why.

The asset data analysis has shown a functionality of systems in June 2015 was 70% which does not support which is greater than the perceived view prior to the asset registration exercise. Therefore it can be concluded that significant progress has been made to improve the sustainability of electric pump systems outside Urban Dili area. This is further supported by the evidence presented for capital maintenance undertaken by a BESIK technical team from 2012 to 2015, with 134 site visits conducted, resulting in 38,200 people with access to an improved water source. It is however clear from the number of outstanding maintenance actions and systems to fix, that there is a resource gap which may be filled by the new pump system technicians.

A discussion of the financial and management models presented tools and methods by which a larger team or several teams may be able fix the current non-functional systems and react swiftly to future pump system break down. Lastly, understanding assets and planning maintenance interventions is not novel in the developed countries, however for a developing country; this represents a pioneering study of electric pump systems. Therefore as Timor-Leste progresses towards its goal for water for everyone by 2030, there are now strategies, resourcing, financial and data management systems being developed to support this.

### Institutional capacity building

The following next steps are being considered and are subject to budget and human resource constraints:

- Consider engaging in partnerships between the government service authority (DNSA) with government (DAA) and non-government accredited service providers to fix the current number of failed systems and monitor these until the capacity of government staff is sufficient;
- Create regional/municipal teams, technically qualified to work on electric pump systems based at a local level to provide better value and more rapid responses;
- Assess the budget requirements based on the data presented for costs of failure and likely failure modes of systems to sustain their operation;
- Establish robust processes for monitoring the functionality of systems;
- Continue to register new systems the SPT<sup>88</sup>;
- Integrate the asset data collected for electric pump systems with existing government systems such as Water and Sanitation System (SIBS);
- Improve logistical management of pump spares and develop evidence of common spare parts needed to allow repair times to be reduced from months to weeks and days over the next few years;
- Liaise with EDTL to improve the power distribution network supply and suggest policy implementation for minimum electrical supply standards to government assets.

### Technical design standards

The revision or inclusion of technical design standards for the following areas should be adopted:

---

<sup>88</sup> SPT – Sector planning tool – currently acting as a national register of water supply systems

## SUSTAINABLE SERVICES

### Finance & Lifecycle Costing

- borehole design and construction
- pump system electrical and mechanical design and construction

#### Further case studies to be assessed:

- Why some pump systems last longer without major maintenance compared to others?
- What pump models are most appropriate to Timor-Leste's environment?
- What technologies can improve the pump control, monitoring and protection?
- Power fluctuations and what technical equipment work may mitigate the issues? including appropriate/affordability technical solutions and policy strategies.
- Studying common failure modes to inform improved system design or operational best practices.
- Establish strategies to minimise outage time and optimise human resource requirements, further developing concept in Figure 3-55.
- Why some Municipal institutional arrangements work better than others? a municipal comparison detailing the relative current success in pump system maintenance. A good case study to refer to is the Electrical Distribution of Timor-Leste (EDTL) who has a 500 strong team which service urban and rural connections across the country.

#### Acknowledgements

Municipality Water Services Managers (DAA) in all municipalities  
Municipality Technical Officers (MTO) in all municipalities  
Administrative Post Facilitators (FPA) in all municipalities  
Inês Freire – DGAS – Directorate General for Water and Sanitation  
Cristina Negut – Mechanical Engineer – Mott MacDonald Limited – Water Division  
Iranga Weerasuriya – Electrical Engineer – Mott MacDonald Limited – Water Division

#### References

- ADB, 2015. *Dili Water Supply - TA 8750*, Dili: Asian Development Bank.
- BESIK, 2015b. *Mechanised pump system data collection*, Dili, Timor Leste: BESIK.
- BESIK, 2015c. *O&M Pathway to Service Delivery (OMP-2-SD): National Pumps O&M Programmer (NPOMP) Proposal*, Dili: BESIK/DNSA.
- BESIK, 2015. *Strategy for maintenance and repair of electrically pumped water supply systems in Timor-Leste*, Dili, Timor Leste: BESIK.
- DNSA, 2012. *Rural Water Supply Guidelines*, Dili: National Department of Water Services.
- DNSA, 2015. *Sistema Informasaun Bee no Saneamento (Water & Sanitation Information System)*, Dili: DNSA.
- GoTL, 2015. *Population and Housing Census 2015: Preliminary Results*, Dili: Government of Timor Leste.
- Nerini, F. D. R. H. M. B. M., 2014. *Estimating the cost of energy access: The case of the village of Suro Craic in Timor Leste*, Australia: Elsevier.
- WASHCost, 2012. *WASHCost Infosheet 3*, Cranfield: WASHCost.
- WSP, 2010. *A review of progress in seven African countries: Public-Private Partnerships for Small Piped Water Schemes*, s.l.: Waret and Sanitation Program.

## SUSTAINABLE SERVICES

### Finance & Lifecycle Costing

---

# Water User Committees using Village Savings and Loans Association for Sustainable O&M of their Water Facility

---

Type: Short Paper

**Authors** *Namata Teo, Project Manager, Amref Health Africa in Uganda, email [teo.environmentalist@gmail.com](mailto:teo.environmentalist@gmail.com), [teo.namata@amref.org](mailto:teo.namata@amref.org) telephone number: +256 782 120420*

### Abstract/Summary

Generally most rural water projects experience problems with Operation and Maintenance (O&M) as well as cost recovery aspects (MWE 2011). In Uganda a number of projects, experience deterioration of newly built infrastructure soon after the project terminates. It is therefore imperative that projects plan for O&M putting into consideration a withdraw mechanism that includes the user community. The basic principle behind this concept is that the user community has a major role in its installation, control and makes decisions over it and carry on the full responsibility for its O&M. Inclusion of user community builds local ownership that contributes to sustainable O&M of the facilities. This paper therefore highlights how the Olam Kala water user committee is applying the Village Savings and Loans Association (VSLA) methodology as a way to sustain O&M of their water facility.

### Introduction

Olam Kara village is located in Bolo Parish, Awere Sub County; Pader District in Northern Uganda with a population of 415 people (58 Households). The village had a shared unprotected well that was used by both community and their animals. Diarrhea was a common problem in the village especially among children. Families had to frequently visit health units and or spend money on treatment; there were loss of production time due to sickness and frequent visits to the health facilities. Talking to members of the water user committee revealed that households would spend between 1-2hrs a day collecting drinking water from an average distance of 2 kilo metres away. A number of other communities within the region experienced this similar problem.

In 2011, most villages where displaced people had returned (after a 20-year decade of insurgency and civil war), water coverage were as low as 30% as opposed to 65% national coverage (MWE 2011). In such a situation, Amref Health Africa with support from the Dutch Ministry initiated a 5 year water and sanitation project (WASH) 2011-2015. The project covered 4 districts of Northern Uganda: Agago, Kitgum, Lamwo and Pader with the main goal of reducing the proportion of the people who are unable to reach or afford safe drinking water and the proportion of people who do not have access to adequate sanitation by half, by 2015. Olam Kara Village was among the selected villages to benefit from this project in 2011 after an assessment of the WASH situation revealed; the village was one of the top needy villages in Bolo Parish. The community was sensitized about what they were required to do before drilling for them a bore hole. This necessitated all households having a toilet, and the capital contribution of UGX 200,000/= which is equivalent to USD 28. The community raised the money and those who never had latrines started digging pits and putting structures. This was led by the Village Health Team members (VHTs).

### Context, aims and activities undertaken

#### Integration of Village Savings and Loans Association (VSLA) into Water User Committees

## SUSTAINABLE SERVICES

### Finance & Lifecycle Costing

Critical to the project success was innovations and participatory approaches. The project integrated an innovative financial inclusion approach- the Village Saving and Loan Association (VSLA) concept into the training of Water User Committees (WUCs) and supported the committees with assorted basic supplies to implement the VSLA concept for WASH sustainability. The introduction of the VSLA concept was to test and pilot a model for sustainable O&M by integrating basic financial literacy training with VSLA. While many banks and Micro Finance Institutions (MFIs) provide valuable services to the poor in the developing world, they are mostly successful in economically dynamic urban or peri-urban areas. Village Savings and Loan Associations based in the community are complementary to MFIs tending to serve the very poor whose income is less reliable, but also offering useful services to the economy of the country. Amref Health Africa worked closely with Micro Finance Institutions including banks and Savings and Credit Co-operative society (SACCO) to ensure that the community is introduced to financial literacy and informed on the different available opportunities for local financing for sustainable WASH.

VSLAs are self-managed groups that do not receive any external capital and provide people with a safe place to save their money, access small loans, and obtain emergency insurance. The approach is characterized by a focus on savings, asset building, and the provision of credit proportionate to the needs and repayment capacities of the borrowers. Groups are low-cost, simple to manage and can be seen as a first step for people to reach a more formal and wider array of financial services. VSLAs can dramatically raise the self-respect of individual members and help to build up social capital within communities, particularly among women who represent approximately 70 percent of members worldwide.

The VSLA model was integrated into the financial management training of 30 WUCs. Each committee was provided training on the six essential elements of VSLA approach, equipped with basic kits – saving boxes, saving and loan books, pens and oriented on the initial processes. Key elements of the VSLA approach covered in the training include the following:

**Self-selection:** In the WASH Alliance project, Amref Health Africa only introduced the concept of savings and loan services to the leadership of the WUCs, facilitated the formation of VSLAs which comprised of 15 to 60 persons. Because trust is fundamental to the effective functioning of a VSLA, members were allowed to select each other to form their group and expand membership to the wider users of the water facility.

**Training:** Training was provided over a few months to help members define the VSLA’s purpose, elect members to serve as officials, and set terms for savings and loans, including interest rates, repayment schedules and penalties for late payments or missed meetings. The group was also trained in a system to collect savings and make loans, record transactions, and run weekly meetings. The methodology offers record keeping techniques suitable for literate and illiterate people.

**Governance:** Each VSLA group elected a chairperson, secretary, treasurer, and two money-counters who form its executive committee. This committee was not the same persons and leadership of the water user committees. In addition, members selected three others and entrusted each with a key to one of the three locks on the cashbox where the group’s funds are kept. This governance structure serves as an internal control system. All transactions –the collection of member savings and the disbursement of loans – are carried out at weekly meetings in front of all members, ensuring transparency and accountability.

**Financial Services:** For Olam Kara Village, VSLAs begun by collecting weekly savings from members. Olam Kara village chose to integrate O&M funds in the VSLA to ensure systematic collection and good management habits to be able to meet maintenance costs of their water point whenever it is required. Savings are accumulated in form of shares at a price agreed upon by the group. The use of shares simplifies record keeping. Once sufficient savings accumulated in the cashbox over four to five weeks, the group started offering loans to members. Typical loans range from \$10 to \$20. The group set an interest rate of 5 percent monthly for loans taken by members and 10% for non-members. At the end of the year, members receive a return on their savings ranging from 30 to 60 percent annually generated from interest and fees collected throughout the year. In addition, VSLAs set up an insurance fund, often called a social

## SUSTAINABLE SERVICES

### Finance & Lifecycle Costing

fund, to enable members to access money in emergencies or at particularly vulnerable times. The group determines if the emergency funds are distributed as grants or as interest-free loans with flexible repayment.

**Audit:** Some nine to twelve months after the VSLA is formed, the group conducts an “action audit” whereby it pays out savings and earnings from interest and fees, closes its books, and disbands. The action audit is usually timed to provide a lump sum to members at critical times in the year when access to money is needed, for example to pay for school fees or inputs at the start of the agricultural season. It also enables members to leave the group and new members to join. Most groups reconstitute themselves and resume the savings and loan process.

**Agency facilitation:** From the start of the VSLA’s operations to the time of the first action audit, the agency observes its meetings and supports the executive committee as needed to ensure that procedures and systems are working well. If there are no issues, the group functions independently thereafter.

### Criteria for being a member of the WUC/VSLA

A member per household benefiting from the water point – priority given to the contributing member joins the group

Willingness of the household member to make a contribution on weekly/monthly basis towards the operation and maintenance of the water source

Members must be willing to attend meetings regularly as scheduled

Financial Analysis

Thirty-three (33) members comprise Olam Kara VSLA. The group has 3 categories of savings made; the social fund meant to support members during difficult times (lose of a close relative). Each member contributes 500 (USD 0.14) monthly. The second category is O&M funds and each member contributes 1000 (USD 0.3) monthly and lastly the individual saving that range from a minimum of 1000-5000 (0.3-1.44) per week. The table below summaries the group saving between May 2015-April 2016 with keen interest on collected funds for O&M of the water facility;

Categories	Total funds saved	Equivalent to USD	Expenditure on O&M	Units	Unit cost	Total	USD
Social fund	173500	50	pipes	3	55000	165000	48
O&M	335000	97	Transport	1	6000	6000	2
Individual Savings	591000	171	Grease	3	3000	9000	3
Total	1099500	319	Labour	1	75,000	75000	22
						<b>255000</b>	<b>74</b>
Balance from O&M		<b>80000</b>					
Opening balance for O&M May 2016 to July 2016	80000	23					
<b>Savings May-July 2016</b>	<b>May</b>	<b>June</b>	<b>July</b>	<b>Total</b>	<b>USD</b>		
Social Fund	16500	16500	16500	49500	14		
O&M	31000	34500	33500	99000	29		
Individual contribution	85000	210000	123000	418000	121		
<b>Available for O&amp;M</b>	<b>80,000+99000</b>	<b>179000</b>	<b>52</b>				

SUSTAINABLE SERVICES

Finance & Lifecycle Costing

The committee revealed that it has done one major repair of their water source by replacing the broken pipes. They conduct monthly assessment of their water point and greasing of the chains and bolts is done frequently.

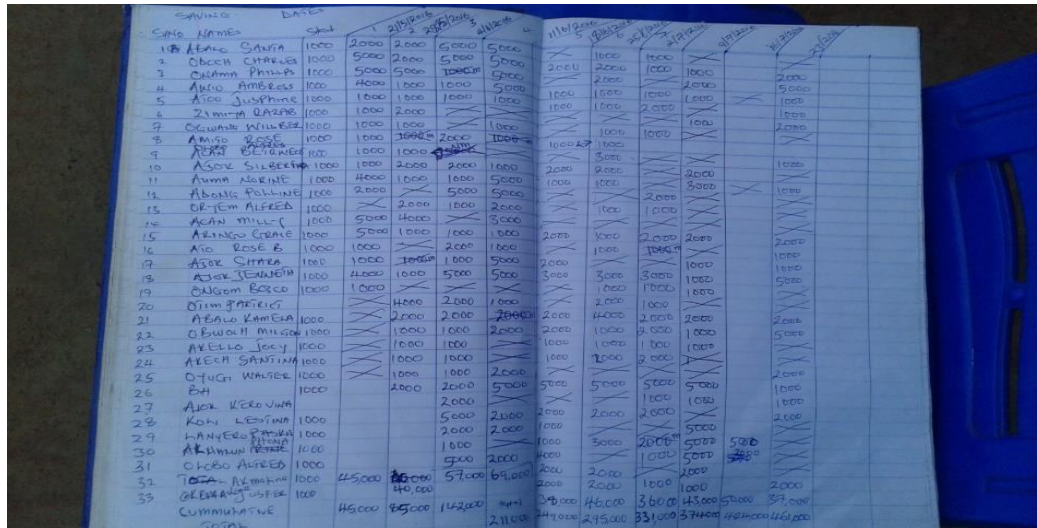

Saving	Name	DATE	2016	2017	2018	2019	2020	2021	2022	2023	2024	2025	2026	2027	2028	2029	2030
1	Abou Samba	1000	2000	2000	5000	5000	5000	5000	5000	5000	5000	5000	5000	5000	5000	5000	5000
2	Abou Charles	1000	5000	2000	5000	5000	5000	5000	5000	5000	5000	5000	5000	5000	5000	5000	5000
3	Abou Philippe	1000	5000	2000	5000	5000	5000	5000	5000	5000	5000	5000	5000	5000	5000	5000	5000
4	Abou Ambrise	1000	1000	1000	1000	1000	1000	1000	1000	1000	1000	1000	1000	1000	1000	1000	1000
5	Abou Josephine	1000	4000	1000	1000	1000	1000	1000	1000	1000	1000	1000	1000	1000	1000	1000	1000
6	Zamina Zaza	1000	1000	2000	1000	1000	1000	1000	1000	1000	1000	1000	1000	1000	1000	1000	1000
7	Clémentine Wilfrède	1000	1000	1000	1000	1000	1000	1000	1000	1000	1000	1000	1000	1000	1000	1000	1000
8	Amadou Boss	1000	1000	1000	2000	1000	1000	1000	1000	1000	1000	1000	1000	1000	1000	1000	1000
9	Alex Belaine	1000	1000	1000	2000	1000	1000	1000	1000	1000	1000	1000	1000	1000	1000	1000	1000
10	Acoué Suleima	1000	1000	2000	2000	1000	1000	2000	2000	2000	2000	2000	2000	2000	2000	2000	2000
11	Amma Aline	1000	1000	1000	1000	1000	1000	1000	1000	1000	1000	1000	1000	1000	1000	1000	1000
12	Abonnie Poline	1000	2000	1000	5000	5000	5000	5000	5000	5000	5000	5000	5000	5000	5000	5000	5000
13	Ortem Alféa	1000	2000	1000	2000	2000	2000	2000	2000	2000	2000	2000	2000	2000	2000	2000	2000
14	Acan Miller	1000	5000	4000	3000	3000	3000	3000	3000	3000	3000	3000	3000	3000	3000	3000	3000
15	Alexandre Corale	1000	5000	1000	1000	1000	1000	1000	1000	1000	1000	1000	1000	1000	1000	1000	1000
16	Ale Rose E	1000	1000	1000	1000	1000	1000	1000	1000	1000	1000	1000	1000	1000	1000	1000	1000
17	Alex Siffre	1000	1000	1000	1000	1000	1000	1000	1000	1000	1000	1000	1000	1000	1000	1000	1000
18	Alex Jeanne	1000	1000	1000	1000	1000	1000	1000	1000	1000	1000	1000	1000	1000	1000	1000	1000
19	Clément Boco	1000	1000	1000	1000	1000	1000	1000	1000	1000	1000	1000	1000	1000	1000	1000	1000
20	Clément Patrick	1000	1000	1000	2000	1000	1000	1000	1000	1000	1000	1000	1000	1000	1000	1000	1000
21	Alela Kamela	1000	1000	2000	2000	2000	2000	2000	2000	2000	2000	2000	2000	2000	2000	2000	2000
22	Clément Milson	1000	1000	1000	2000	1000	1000	1000	1000	1000	1000	1000	1000	1000	1000	1000	1000
23	Alela Jody	1000	1000	1000	1000	1000	1000	1000	1000	1000	1000	1000	1000	1000	1000	1000	1000
24	Alela Santina	1000	1000	1000	1000	1000	1000	1000	1000	1000	1000	1000	1000	1000	1000	1000	1000
25	Clément Walter	1000	1000	1000	1000	1000	1000	1000	1000	1000	1000	1000	1000	1000	1000	1000	1000
26	El	1000	2000	2000	5000	5000	5000	5000	5000	5000	5000	5000	5000	5000	5000	5000	5000
27	Alex Véro Van	1000	2000	2000	2000	2000	2000	2000	2000	2000	2000	2000	2000	2000	2000	2000	2000
28	Katy Lesma	1000	5000	2000	2000	2000	2000	2000	2000	2000	2000	2000	2000	2000	2000	2000	2000
29	Amara Patricia	1000	1000	1000	1000	1000	1000	1000	1000	1000	1000	1000	1000	1000	1000	1000	1000
30	Amama Pierre	1000	1000	1000	1000	1000	1000	1000	1000	1000	1000	1000	1000	1000	1000	1000	1000
31	Clément Alfred	1000	5000	2000	2000	2000	2000	2000	2000	2000	2000	2000	2000	2000	2000	2000	2000
32	Clément Alphonse	1000	25000	20000	57000	64000	2000	2000	2000	2000	2000	2000	2000	2000	2000	2000	2000
33	Clément Joseph	1000	45000	40000	112000	140000	2000	2000	2000	2000	2000	2000	2000	2000	2000	2000	2000
34	Clément Cumulative	1000	45000	40000	112000	140000	2000	2000	2000	2000	2000	2000	2000	2000	2000	2000	2000
TOTAL			45000	40000	112000	140000	2000	2000	2000	2000	2000	2000	2000	2000	2000	2000	2000

Comparison with Cubu A & B VSLA in Tegwana Parish Gulu Municipality

It was thought useful to make a comparison between a number of VSLA groups integrated into WUC to test the applicability of the approach for possible scale up.

Cubu A and B has got 34 HHs and each collects UGX 2000 (USD 0.6) for O&M of their water point on a monthly basis and receipts are given whenever payment is made. The committee revealed that their water point has a total of 7 pipes of which 6 have been replaced. Their plan is to replace the 7th pipe. Once the 7th pipe is replaced, they will be spending less on O&M of their water point.

Record keeping is vital on every day's savings made

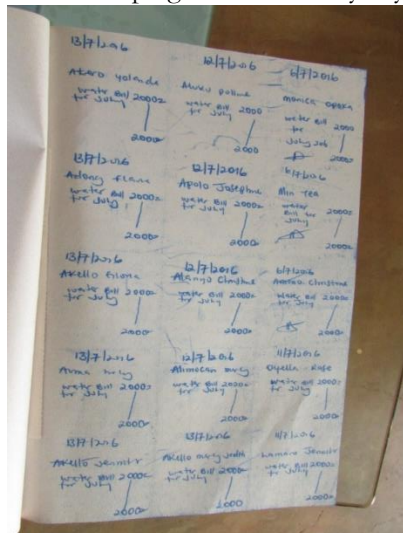

Handwritten receipts for water point payments, showing names and amounts collected for July.

Below is a summary table for the tariffs collected and expenditures on O&M through the VSLA.

Income 2015	HH	Unit collection (UGX)	Monthly	Expenditures 2015	Units	Unit cost	Freq	Total	USD
	34	2000	68000	Replacement of pipes	4	65000	1	260000	75



## SUSTAINABLE SERVICES

### Finance & Lifecycle Costing

		12	816000	Transport	1	8000	1	8000	2
USD			237	Labour	1	80000	1	80000	23
				Facilitation to the care taker	1	20000	12	240000	70
				Grease	1	3000	2	6000	2
								<b>594000</b>	<b>172</b>
Balance			222000	Expenditures during 2016					
USD			64	Replacement of pipes	2	65000	1	130000	38
Opening balance 2016			222000	Transport	1	4000	1	4000	1
Collections January-August 2016				Labour	1	80000	1	80000	23
	34	2000	8	Facilitation to the care taker	1	20000	8	160000	46
Total			<b>766000</b>	Grease	1	3000	1	3000	1
USD			222					<b>377000</b>	<b>109</b>
Available balance			<b>389000</b>						
USD			<b>113</b>						

### Main results and lessons learnt

Good O&M of the water facility (well fenced, cleaned and functioning WUC that ensures repair and maintenance of the water point whenever it is required.

The good cooperation and understanding between users and user committees has led to good O&M of their water facility. Both users and committees play their responsibility (fencing off the water facility, maintaining it clean, collecting user fees and repairing it whenever need be. As a result, this WUC/VSLA has become a reference point for many other WUC/VSLAs established and trained.



*Cubu A&B water source*

Access to loans at a reduced and affordable interest rate of 5%. All water users and WUC/VSLA committee members have equal opportunity to access loans from the collected money at a reduced interest rate

## SUSTAINABLE SERVICES

### Finance & Lifecycle Costing

determined by them. As a result, many of the members 65% started up small businesses; others are educating their children using this money and pay back latter especially after harvesting their produce. Some members have acquired solar lighting systems from their accumulated saving hence saving them from the risk of respiratory diseases as a result of using diesel/kerosene lantern for lighting houses.

Access to safe water combined with good hygiene practices has led to reduced incidences of diarrhoea occurrence from 5 to 1 a week and other water related problems as per medical records in Boro Parish thus reduced expenditure on medication. With good health, the user community has been able to work intensively, using their water facility for multiple purposes (domestic use, brick making, watering their vegetables and for their animals. For example, some members benefiting from this water facility had this to say;

“My family member collects enough water for domestic use and I collect more water for making bricks and watering of my kitchen garden” (Patrick Orin 53-year-old narrated). I have so far made 20,000 bricks this season February-March 2015 and whenever i sell off my bricks, I contribute UGX 10,000 to the O&M fund for this borehole. As a member of the WUC/VSLA, i pledge to ensure that this water source is well maintenance (Patrick said).

Adio Rose (one of the water users) had this to say “I used to spend 3hours a day collecting 3 jerry cans from 2 kilo metres away”. This water was not enough for my home including my animals. With access to a nearby safe water source in my village now, I am able to collect more than 6 jerry cans a day without wasting much time. This water is enough for our domestic use including animals.

### Lessons Learnt

Integration of VSLA into WASH has multiple benefits including creating an O&M fund, access to loans at affordable rate to start up business and meeting other necessities. However, it is important to train the established WUC and the VSLA committees on the six essential elements of VSLA approach (self-selection, training, governance, financial services, and audit and agency facilitation.

The user community must be involved right from problem assessment and in all stages of project implementation to build local ownership and be able to make decisions that contributes to sustainable O&M of their facilities.

Community’s realization and putting their water source to alternative uses (for example brick making, collecting water for their animals and irrigation of their kitchen gardens) makes them more appreciative, builds their ownership as well as ensuring good O&M of their facility.

Knowledge, experiences and skills sharing among the different stakeholders are a key in the successful promotion of hygiene and sanitation in the communities and replication of best practices.

### Possibility for scaling up the intervention

The idea of integrating VSLA with WUC is scalable due to the fact that VSLA have widely spread across all districts and community members are already benefiting from it. Since there is consistent meeting and saving, it is easier to integrate saving for O&M than the normal collection of user fees that is normally done when the water point breaks. Up to 12 VSLA groups (05 in Pader, 0 4 in Agago and 03 In Lamwo have adopted this approach after learning from Olam Kara village.

### Conclusions and Recommendations

The VSLA methodology/concept incorporated into the O&M training brings good results and promotes sustainable O&M of the facility. This strengthens ownership and participation of users in O&M as they also benefit from simple loans with low interest rate.

### Acknowledgements

## SUSTAINABLE SERVICES

### Finance & Lifecycle Costing

*The authors would like to extend thanks to all members of Olam Kala Village for the initiative taken to ensure sustainable O&M of their water facility and the Dutch Ministry for funding this project through WASH Alliance Project.*

#### **References**

*MWE (2010) Uganda Water and Sanitation Works Sector Performance Report. Ministry of Water and Environmental, Kampala Uganda*

*MWE (2011) Uganda Water and Sanitation Works Sector Performance Report. Ministry of Water and Environmental, Kampala Uganda*

## SUSTAINABLE SERVICES

### Government, Decentralisation & Governance

#### 3.3.4 Government, Decentralisation & Governance

---

# Implementing the right to water - water policy choices with decentralised politics in Kenya

---

Type: Short Paper

**Author:** Johanna Koehler, Researcher, Smith School of Enterprise and the Environment, University of Oxford, United Kingdom

**Email:** [Johanna.Koehler@ouce.ox.ac.uk](mailto:Johanna.Koehler@ouce.ox.ac.uk); **Tel:** +44 7748906525

#### Abstract/Summary

To achieve universal access to water in line with the human rights criteria of sufficient quantity, potable quality, affordability, physical access and non-discrimination, we require a better understanding of how decision-makers interpret their mandate and translate it into implementation strategies. This research is the first of its kind that captures all 47 decision-makers charged with the service delivery mandate in Kenya's newly devolved system. Understanding the political and socio-climatic factors influencing water policy choices is critical for private sector or non-governmental organisations to effectively contribute to improved water provision, especially in rural areas. This paper's insights are transferrable across other countries that have decentralised systems of water provision. Achieving the SDG target on water starts with the acknowledgement and uptake of the mandate by decision-makers prior to measuring progress. If fast progress is to be achieved, adapting strategies to the socio-political realities of countries and their sub-national institutions is critical.

#### Introduction

One of the promises of decentralisation is improved service delivery (Lein & Tagseth, 2009; Nsibambi, 1998; Palotti, 2008; Uhlendahl et al., 2011). Another is higher levels of accountability between policy-makers and citizens (Faguet, 2014; Rogers & Hall, 2003; Shah & Huther, 1999). This paper examines Kenya's decentralisation process and its implications for water service delivery – in particular to what extent decentralisation benefits the rural poor in accessing water services. It assesses a newly defined contract derived from the human right to water between duty-bearers and rights-holders, policy-makers and voters.

Approaching Kenya's second general election in August 2017 in its newly decentralised system, the centre of attention is not only on the presidential campaigns but also on the race over the governors' seats in the 47 counties. The election promise of easily accessible, safe and reliable water services has become an important policy tool for county governments in running for re-election. This paper examines factors that influence county water ministries' policy choices in interpreting their new mandate, establishing their new water institutions and developing county water policy. It further examines how this mandate is translated into budget allocations and service provision arrangements and provides novel insights for third-party organisations working with county governments in advancing the water goal of the sustainable development agenda.

#### Context, aims and activities undertaken

International and national frameworks prescribe water policy choices. The political challenge of meeting sub-goal 6.1 of the sustainable development agenda – achieving universal and equitable access to safe and affordable drinking water for all by 2030 – is manifold. As part of its path towards a middle-income country (Government of Kenya, 2007), Kenya subscribed to advancing the Human Right to Water and Sanitation, including the attainment of the criteria of sufficient quantity, potable quality, affordability, physical accessibility and non-discrimination. These criteria became a constitutional right in Kenya with the 2010 constitution. The right to water is enshrined in article 43 1(d) as “every person has the right to clean and safe water in adequate quantities” (Government of Kenya, 2010).

This research evaluates a unique dataset covering responses of all 47 county water ministries (100%) in Kenya, and participant observation at the first summit of Kenya's county water ministers in

## SUSTAINABLE SERVICES

### Government, Decentralisation & Governance

October 2015 organised by the Water Services Trust Fund, at which the framework for a prototype County Water Bill was developed as basis for future water policy (Mumma & Thomas, 2016). The research was conducted in collaboration with the national government institution, the Water Services Trust Fund. County water policy choices are measured here in terms of subjective statements by county water ministries as counties are only in the process of establishing their policy strategies and county water laws. Whilst these responses do not constitute laws, they provide an indication of the interpretation of county mandates at the end of the three-year transition period. They are supplemented by semi-structured interviews at national and county level and data by the national regulator (WASREB, 2013).

The key objectives of this work are to investigate the water policy choices of the newly established 47 county governments and to learn which factors influence their decision-making process; to learn how the affordability criterion is translated into ‘fair tariffs’, and to test whether decentralisation leads to improved water services and really benefits the rural poor. These insights are deemed critical for any organisation working on water service delivery in Kenya.

### Main results and lessons learnt

The central expectation of rights-holders is efficient and reliable service delivery – which places high political pressure on duty-bearers. Legal frameworks are currently being developed. Kenya’s national Water Bill, 2014, just passed through the Senate, is expected to be passed as Kenya’s new Water Act this year (Republic of Kenya, 2014). All 47 counties are also currently developing their own county legislation and translating international and national frameworks into their own laws. We examine the water policy choices of county water ministries, especially with regard to the five human rights criteria and service provision arrangements.

### What are the priorities in the water sector?

With decentralisation the financial architecture for rural water service provision has changed in Kenya. Across all counties the water budget ranks fourth after health, transport and education. The majority of counties spend more than 75 per cent of their water budget on developing new water service infrastructure. This allocation has important implications for the maintenance of existing infrastructure and the sustainability of delivering water services. We found the allocations within the county water budget to be a significant factor in the level of responsibility county water ministries have with respect to the human rights criteria.

### Do county water ministries’ policy choices align with their constitutional obligation?

The constitutional obligation of the right to water is unambiguous – but are the human rights criteria universally acknowledged across the 47 counties? Article 174 (f) states that the objectives of the devolution of government include “the provision of proximate, easily accessible services throughout Kenya” (Government of Kenya, 2010). However, when county water ministries were asked whether they acknowledge responsibility of the five categories of sufficient quantity, potable quality, affordability, physical access and non-discrimination for water services provision, the response was mixed. We disaggregated the question for urban and rural areas. While none of the responses falls below the 50 per

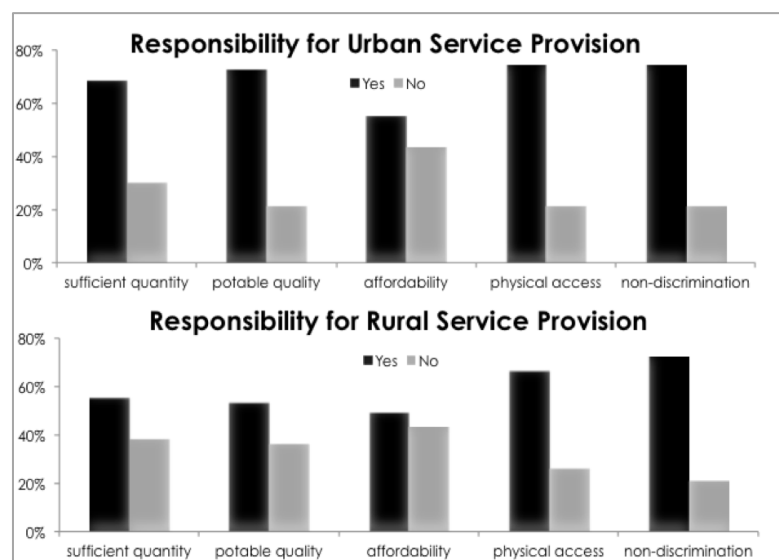

Figure 1. Water service responsibilities for urban and rural areas

## SUSTAINABLE SERVICES

### Government, Decentralisation & Governance

cent mark, there are some striking differences. Only about two-thirds of the counties acknowledge responsibility for providing “sufficient quantity” for urban areas and even fewer (59 per cent) for rural areas. Potable quality is slightly higher at 77 per cent for urban and 50 per cent for rural. Affordability is the most contested criterion: just over 50 per cent of water ministries consider affordability their responsibility across urban and rural. Physical access and non-discrimination constitute the most accepted responsibilities for urban and rural areas within the 70 to 80 per cent range. These variations have important implications for the SDG process and the longer-term impact of decentralisation on regional development, especially in rural Kenya.

#### Which factors influence water policy choices?

We examine a number of political and socio-climatic factors that may influence some of the water policy choices across the 47 counties. The analysis suggests that a wider election margin is associated with a lower degree of responsibility for the five criteria across urban and rural areas, a higher poverty rate and a higher level of urbanisation are associated with a higher degree of responsibility, a higher county water budget (as part of total county budget) as well as a higher degree of water service satisfaction are also associated with a higher degree of water service responsibilities. And higher baseline water coverage appears to be associated with a lower degree of water service responsibilities.

More specifically, a widening of the election margin from one to ten per cent as well as from ten to 30 per cent is associated with a decrease in the level of responsibility by ten per cent respectively. Literature supports this finding. For example, in an article examining primary education spending among 29 Mexican states (1999-2004), Hecock (2006) shows that greater electoral competition leads to increased spending. This is an important finding as it implies that decentralisation may have a positive impact on the accountability level of decision-makers.

#### How is the mandate translated into service provision arrangements?

We also examined how the water service mandate is being implemented across the 47 counties. 72 per cent of the counties opted for two (38%) or several (34%) utilities as the best service provision arrangement for their county. Rural utilities become a feasible option for many counties. Public provision is the preferred choice for both urban (81%) and rural areas (51%) with 28 per cent considering community management as the best arrangement for rural service provision. Private sector involvement through either PPPs or fully private companies is preferred by 28 per cent of the counties for both urban and rural areas.

#### Who pays for water services? Are rural and urban tariffs comparable?

It is striking that the average fair tariff for rural water provision (USD/m<sup>3</sup>) was defined 29 per cent higher than for urban, whereas a fair provision level was defined 12 litres per capita per day lower for rural. This difference may partially be accounted for by the fact that urban tariffs were asked per cubic metre and rural tariffs were provided per 20-litre jerrican. But it reflects the reality on the ground. Moreover, on average those counties that face high electoral pressure have lower tariffs, but so do those counties with lower poverty rates. This may be attributed to a number of reasons: First, affordability is relative; ‘fair tariffs’ may take into account the reality of given socio-climatic risks in each county and the cost to tackle them. Second, counties with mainly rural areas tend to have higher poverty rates. They also tend to be drier, which has effects on the cost of provision.

40 per cent of the counties state that users should pay the full cost of water provision. Of those counties supporting subsidies, the majority (57%) state that county governments should pay for the subsidy, followed by donors (26%) and the national government (23%).

**Table 1: Fair tariffs and provision levels**

Measure	Urban (n=46)				Rural (n=47)			
	Mean	SD	Min	Max	Mean	SD	Min	Max
Fair Tariff (USD/m <sup>3</sup> )	1.15	1.05	0.49	>4.93	1.43	1.08	0.49	>4.93
Fair Drinking Water Provision Level (l/c/day)	43	12	10	>50	31	14	10	>50

## SUSTAINABLE SERVICES

### Government, Decentralisation & Governance

#### **The role of the regulator in streamlining water service provision across a nation:**

The role of regulation is critical in managing the different expectations of the mandate for the right to water and the service provision arrangements across one country. 80 per cent consider the national government (WASREB) responsible for regulation while seven per cent consider it a shared function with county governments and the rest attribute it to county governments.

#### **Conclusions and Recommendations**

This research identifies important issues emerging in the devolved water sector that can contribute to the development of county legislation and water services sustainability in the future. The findings show that the counties are heading into the right direction, however, there are key implications that need to be taken into account when policies are developed and implemented that are also relevant for other countries in sub-Saharan Africa undergoing institutional transformations in the form of decentralisation:

*First*, county water policy choices need to be streamlined across the human rights criteria so that regional disparities do not grow and transformative development is sustained, especially for the rural, marginalised areas. *Second*, major investments are made in new infrastructure development for water services. However, without a higher priority on monitoring and maintenance provision, the sustainability of this infrastructure is not provided and SDG goal 6.1 is unlikely to be achieved in the long term. *Third*, it appears that a healthy level of democratic competition in the gubernatorial elections drives the water service agenda and the fulfilment of the constitutional obligations. It is certainly true that county water ministers (as appointed by the governors) drive their agenda with the view to fulfil the election promises to achieve re-election. This is why regulation at an overarching level is a key determinant in managing democratic processes and ensuring that all people are reached. *Finally*, responsibilities across the five categories are driven by a number of political and socio-climatic factors. Countries do not respond uniformly, especially if they have a devolved system of government. The question of achieving SDG targets starts with the acknowledgement and uptake of their mandate by decision-makers before we even start to measure progress. If we want to achieve fast progress, then adapting strategies to the socio-political realities of countries and their sub-national institutions is critical.

#### **Acknowledgements**

We would like to thank the Water Services Trust Fund, Kenya, for the opportunity to conduct this survey at the Baringo Meeting in October 2015. We also would like to thank all county governments for participating in this research. This work was supported by the UK Department for International Development, the UK Economic and Social Research Council and the Oxford University Clarendon Fund.

#### **References**

- Faguet, J.-P. (2014). Decentralization and Governance. *World Development*, 53, 2–13. doi:10.1016/j.worlddev.2013.01.002
- Government of Kenya. (2007). *Kenya: Vision 2030*. Nairobi.
- Government of Kenya. (2010). *The Constitution of Kenya*. Nairobi: National Council for Law Reporting.
- Hecock, R. D. (2006). Electoral Competition, Globalization, and Subnational Education Spending in Mexico, 1999–2004. *American Journal of Political Science*, 50(4), 950–961.
- Lein, H., & Tagseth, M. (2009). Tanzania water policy reforms – between principles and practical applications. *Water Policy*, 11, 203–220.
- Mumma, A., & Thomas, M. (2016). Prototype County Water Services Bill, 2016. Council of Governors. Unpublished manuscript.
- Nsibambi, A. (1998). *Decentralisation and Civil Society in Uganda: The Quest for Good Governance*. Kampala: Foundation Publishers.
- Palotti, A. (2008). Tanzania: Decentralising Power or Spreading Poverty? *Review of African Political Economy*, 35(116), 221–235.
- Republic of Kenya. (2014). The Water Bill, 2014. Nairobi: National Assembly. Retrieved from <http://kenyalaw.org/kl/fileadmin/pdfdownloads/bills/2014/WaterBill2014.pdf>
- Rogers, P., & Hall, A. (2003). Effective Water Governance. *TEC Report, Global Water Partnership*.
- Shah, A., & Huther, J. (1999). *Applying a Simple Measure of Good Governance to the Debate on Fiscal*

## SUSTAINABLE SERVICES

### Government, Decentralisation & Governance

*Decentralization.* Washington, D.C.: The World Bank.

Uhlendahl, T., Salian, P., Casarotto, C., & Doetsch, J. (2011). Good water governance and IWRM in Zambia: Challenges and chances. *Water Policy*, 13, 845–862. doi:10.2166/wp.2011.155

WASREB. (2013). *IMPACT 2013 - A Performance Review of Kenya's Water Services Sector 2011-2012*. Nairobi: WASREB.

*Note: This paper draws on on-going research. For ethical reasons (anonymity) the underlying data of the figure cannot be shared as it would reveal county-by-county responses and can be tracked back to individual respondents. If another version of the figure is required, please do let me know and I will provide it in the required format. Thank you for your understanding.*



SUSTAINABLE SERVICES

Government, Decentralisation & Governance

# Experiencias locales en la gestión del agua: Gobernanza del agua y gestión integrada de los recursos hídricos promovida por mancomunidades de municipios de Bolivia

Type: Long Paper

Authors *Equipo Proyecto Gestión integral del agua (Cooperación Suiza – HELVETAS Swiss Intercooperation)*

## Abstract/Summary

Los recursos hídricos están bajo creciente presión para satisfacer las necesidades de los usuarios en los niveles local y nacional. En Bolivia, debido a diversos factores (ej. contaminación, uso inadecuado, sobre-explotación, variabilidad climática), la disponibilidad y el acceso al agua limpia y segura se redujo. Este contexto obliga a proteger las fuentes de agua y gestionar los recursos hídricos de las cuencas más eficientemente a objeto de beneficiar a las poblaciones urbanas y rurales en armonía con la madre tierra. Los conflictos y mayor competencia por el agua son principalmente una problemática de gestión del agua y de los recursos naturales en la cuencas que involucra a diferentes actores. En ausencia de una efectiva gobernanza del agua en cuencas, tomadores de decisión y actores locales enfrentarán obstáculos para diseñar e implementar reformas y acciones en pro de una gestión integrada del agua y los recursos naturales en cuencas. Sin reglas claras para tomar decisiones, una inadecuada organización pública y social, participación débil y poco proactiva, y deficiente capacidad de coordinar y llegar a acuerdos, la gestión del recurso hídrico en las cuencas será insostenible.

Este artículo presenta cuatro de dieciocho<sup>89</sup> experiencias desarrolladas por mancomunidades de municipios<sup>90</sup> rurales en Bolivia (Héroes de la Independencia (Tarija), Chuquisaca Centro (Chuquisaca), Cuenca del Caine (Cochabamba), y Norte de Potosí (Potosí)) que vinculan la gobernanza local con la gestión integrada de los recursos hídricos y naturales en cuencas, en el marco del proyecto de Gestión de recursos naturales y cambio climático<sup>91</sup> de la Cooperación Suiza en Bolivia implementado por HELVETAS Swiss Intercooperation.

## Introduction

Más del 50% de los municipios en Bolivia enfrentan problemas de degradación de sus recursos hídricos tanto por la acción antrópica y la variabilidad climática (sequías cada vez más recurrentes), como por las limitadas capacidades para generar políticas públicas de gestión integrada de los recursos hídricos y de gestión de cuencas. La gestión de los recursos hídricos en cuencas busca la conservación y aprovechamiento del agua, lo que abarca la protección, manejo y buen uso de los demás recursos naturales que condicionan el estado de las fuentes y zonas de recarga hídrica: vegetación circundante, capacidad de penetración y retención del agua, ausencia de contaminación en las fuentes, y adecuadas prácticas culturales (León & Prins, 2009). Además, la conservación del agua requiere buenas prácticas agropecuarias en las zonas de recarga. Sin embargo, la gestión de los recursos hídricos en cuencas no es suficiente para alcanzar resultados sostenibles, sino que necesita procesos adecuados de gobernanza que consoliden su apropiación, concertación y empoderamiento (Prins & Kammerbauer, 2009). Las prácticas de gobernanza del agua en cuencas promovidas por las mancomunidades, municipios y comunidades para la protección de fuentes de agua y acuíferos, buscando el uso eficiente del agua, muestran que su efectividad depende en gran medida de la apropiación local. Ésta apropiación existe cuando se identifica y

<sup>89</sup> Ver gráfico 1

<sup>90</sup> La mancomunidad es un mecanismo establecido en la normativa boliviana que permite a gobiernos municipales implementar acciones que sólo no las pueden desarrollar. El proyecto Gestión de recursos naturales y cambio climático utilizó este mecanismo para implementar acciones de manejo de recursos naturales dado que el manejo de recursos naturales supera los límites administrativos de los municipios.

<sup>91</sup> Este proyecto tuvo una duración de 4 años (2010-2014), posteriormente tuvo una siguiente fase (2014-2018) que pasó a llamarse: Gestión integral del agua, también implementado por HELVETAS Swiss Intercooperation.

## SUSTAINABLE SERVICES

### Government, Decentralisation & Governance

responde oportunamente a las necesidades de la población; se acuerdan y respetan reglas de acceso y uso; se aprende y construye horizontalmente promoviendo la participación con interculturalidad, la concertación y la organización social; y se institucionalizan estructuras y prácticas que acercan a los diferentes actores de una cuenca. Las experiencias que se presentan muestran como se ha superado la falta de articulación de iniciativas de gestión de microcuencas (muchas veces vistas erróneamente solamente como de protección del medioambiente) con actividades productivas que brinden beneficios económicos (Héroes de la Independencia), garantizado la coordinación y concertación entre múltiples actores logrando una mayor eficiencia en el desarrollo de iniciativas de conservación de ecosistemas sistemas en las cabeceras de cuencas y mejorando los medios de vida local (Chuquisaca Centro), y han desarrollado acuerdos con base a sus usos y costummbres para la recuperación de tierras en microcuencas reduciendo así niveles de pobreza y conflictividad de las familias campesinas (Cuenca del Caine y Norte de Potosí).

#### Description of the Case Study – Approach or technology

En este documento se entiende la gobernanza como las cualidades, reglas y fórmulas que posibilitan una relación estable entre actores estratégicos de una sociedad, quienes de manera conjunta pueden aportar al efectivo, legítimo y democrático ejercicio de gobierno (Kooiman, 2004); en este sentido, la gobernanza del agua y los recursos naturales en cuencas es “el conjunto de instituciones formales e informales, a través de las cuales las familias, organizaciones sociales, instituciones y diferentes grupos de interés, median sus diferencias y ejercen sus derechos y obligaciones en relación al acceso y uso equitativos del agua y de los recursos naturales de la cuenca. Las experiencias desarrolladas en estas cuatro cuencas resaltan de manera especialmente los siguientes elementos de gobernanza: *organización* para una adecuada gestión hídrica, *participación* efectiva en un marco de interculturalidad, *concertación y articulación* entre actores a múltiples niveles, y generación de *políticas públicas y normativa* local.<sup>92</sup>

Las cuencas y microcuencas donde se implementaron los proyectos con las mancomunidades de municipios, son sitios donde las medidas de gestión y manejo del agua y los recursos naturales asociados, se combinaron con los procesos de concertación, marcos institucionales, normativos, culturales y económicos del nivel departamental, municipal y local. No se esperó a contar con un plan de gestión y manejo integral de cuencas, que en la mayor parte de los casos toma mas de un año para su formulación, sino que se inició el trabajo con la información disponible y la acciones priorizadas por los familias, comunidades y municipioc dentro de su visión de futuro para el desarrollo de la cuenca. A través de iniciativas piloto/demostrativas se aprendieron lecciones a la vez que el entendimiento entre los diferentes actores creció, permitiendo que los socios de los proyectos y los actores participantes ganen confianza entre ellos.

#### Contexto / caracterización de las áreas de intervención.

**Mancomunidad Héroes de la Independencia - Cuenca Tajzara, Tarija<sup>93</sup>:** La Cuenca Endorreica de Tajzara con una superficie de 340 km<sup>2</sup> está ubicada en el Municipio de Yunchará, departamento de Tarija, pertenece al ecosistema altiplánico rodeada por la Serranía del Sama y la Serranía de Viscarra, cuyas aguas fluyen a una extensa llanura fluviolacustre que conforman las Lagunas de Tajzara. Este ecosistema dada las características de la flora, fauna y por albergar a los acuíferos de la Serranía de Sama (fuente de provisión de agua del Valle Central de Tarija), ha sido declarada como la “Reserva Biológica Cordillera de Sama”. La cuenca se encuentra a un altitud entre los 3700 a 4000 msnm, con temperaturas promedio entre los 6 a 8 °C, y una precipitación promedio anual entre 300 a 480 mm. La principal actividad económica en la cuenca es la ganadería principalmente ovina y más recientemente la camélida.

En la serranía oriental de la cuenca se presentan la mayor cantidad de fuentes de agua con caudales que varían en la época lluviosa entre 0.22 a 3.3 l/s. En la serranía oeste de la cuenca (Serranía de Viscarra), las fuentes de agua son muy escasas y de muy bajo caudales, con caudales que varía entre 0.007 a 0.03 l/s en la época lluviosa. En la parte central de la cuenca se encuentra las lagunas, tres de ellas mantienen su

<sup>92</sup> Ver gráfico 2.

<sup>93</sup> Ver gráfico 3.

## SUSTAINABLE SERVICES

### Government, Decentralisation & Governance

espejo de agua todo el año y otras cinco son temporales; a estas áreas concurren todas las aguas provenientes de ambas serranías.

**Mancomunidad Chuquisaca Centro - Cuenca Escaleras, Chuquisaca<sup>94</sup>:** La cuenca Escaleras está ubicada dentro del municipio de Villa Serrano del Departamento de Chuquisaca. La cuenca tiene una superficie de 83 km<sup>2</sup> con una altura que varía entre 2100 y 3000 msnm. La cuenca se caracteriza por contar con fuentes de agua (vertientes y ríos) de buena calidad. Los caudales disminuyen considerablemente en la época seca (mayo a noviembre). La cuenca tiene una red de drenaje muy bien desarrollada con zonas de bosque húmedo que protege el recursos agua, otorgando a sus agricultores la presencia de muchas vertientes de agua que están siendo utilizadas, el desafío es realizar un buen manejo de estas fuentes de agua y fomentar los tipos de utilización del territorio que vayan a mantener el equilibrio hidrológico y ecológico.

**Mancomunidad Cuenca del Caine: Cuenca Laka Laka, Cochabamba<sup>95</sup>:** La Cuenca Laka Laka se encuentra a 35 km al sudoeste de la ciudad de Cochabamba. Es parte del Valle Alto de Cochabamba. La cuenca tiene 59 km<sup>2</sup> con un rango altitudinal que varía entre 2780 a 3500 msnm. La cuenca tiene clima semiárido con una alta déficit hídrico en la época seca (abril a noviembre). La estación Tarata muestra una precipitación anual que varía entre 300 a 600 mm y un promedio de precipitación de los últimos 40 años de 550 mm que ocurren entre Diciembre y Marzo. La temperatura máxima promedio varían poco durante el año (23 °C–26 °C) sin embargo la temperatura promedio mínima baja considerablemente durante el invierno de 10.2 °C en Enero (verano) a -1.0 °C y -1.5 °C en Junio y Julio. A la salida de la cuenca se construido la represa de Laka Laka. La degradación de la cuenca ha conducido a una rápida sedimentación del reservorio y la disminución drástica de su vida útil. La capacidad inicial del reservorio construida en 1993 fue de 2.7 millones de m<sup>3</sup>, sin embargo más del 25% de su capacidad se perdió al inicio del 2000. Para el 2005, la capacidad se redujo en al menos 40%. La la tasa de aporte de sedimentos obtenida, para la cuenca alcanza a un promedio de 1557 m<sup>3</sup>/año/km<sup>2</sup>. Así la capacidad actual de almacenamiento es menor a 1.5 millones de m<sup>3</sup> el cual es insuficiente para satisfacer el riego de 800 has en la época seca.

**Mancomunidad Norte Potosí - Región del Norte de Potosí, Potosí<sup>96</sup>:** La región comprende a 13 municipios del Norte de Potosí, que abarcan una superficie de 12834 km<sup>2</sup>. La zona abarca una superficie de 12834 km<sup>2</sup>, Desde el punto de vista hidrológico la zona corresponde a la cabecera de la cuenca del Río Grande. La altura en la región oscila desde los 1640 en la confluencia de los ríos Caine y San Pedro hasta los 4675 msnm en el sector de Llallagua. El régimen térmico llega a temperatura máximas promedio sobre los 25 C en verano, disminuyendo a unas 20 C en las cabeceras de valle y todavía muy bajas en las zonas altas de la región que en promedio oscilan entre 6 a 10 C. la precipitación promedio anual de la región es de 500 mm. Se ha estimado que el total de agua disponible en el Norte de Potosí alcanza a 350 millones de m<sup>3</sup>, de los cuales para satisfacer la demanda estacional para todos los usos del agua sería necesaria regular adicionalmente más de 200 millones de m<sup>3</sup>. Por lo cual y dado el extremo déficit hídrico en esta regional se requiere de obras de regulación a través represas medianas, estanques y atajados. Finalmente se ha estimado que cerca del 92% del territorio está afectado por diversos grados de degradación de la tierra siendo los más importantes la erosión del suelo, la compactación, y la contaminación de los suelos

### Main results and lessons learnt

Como resultado del análisis de las experiencias de las cuatro regiones antes mencionadas se han identificado los mecanismos de gobernanza del agua y recursos naturales a nivel de las cuencas que a continuación se detalla:

El mecanismo de gestión integral de microcuencas se implementó en el territorio de la mancomunidad **Héroes de la Independencia**. La **gestion** de la microcuenca se sustentó en la negociación y

<sup>94</sup> Ver gráfico 3.

<sup>95</sup> Ver gráfico 4.

<sup>96</sup> Ver gráfico 4.

## SUSTAINABLE SERVICES

### Government, Decentralisation & Governance

concertación entre las comunidades (productores de camélidos) para promover un uso eficiente del agua, la recuperación de pasturas naturales (bofedales) y la recuperación de las lagunas de Tajzara. Este modelo se aplicó en tres microcuencas de la cuenca del río Tajzara, en sus tres componentes: *a*) manejo, protección y conservación de fuentes de agua para incrementar los volúmenes de agua (oferta del agua), para lo que las comunidades realizaron cerramientos a pequeña escala, plantaciones forestales con especies nativas alrededor de las fuentes, la construcción de zanjas de infiltración para favorecer la recarga de acuíferos y la impermeabilización de atajados existentes para mejorar la eficiencia de captación y almacenamiento del agua; *b*) conducción y uso eficiente del agua (parte media de la microcuenca) para lo cual se construyeron estanques intermedios de ferrocemento, rehabilitado y mejorado los sistemas de canales de conducción y distribución (por entubado) logrando así la reducción de pérdidas hasta en un 60%; *c*) a nivel de parcela (zona baja de la microcuenca) se ampliaron las áreas de producción para cultivos básicos y forrajes, y se mejoró los sistemas de riego parcelario promoviendo el riego tecnificado (riego por aspersión).

El esquema implementado por la mancomunidad **Chuquisaca Centro** se orientó al establecimiento de Áreas de Reserva Natural del Agua (ARENAS) en las partes alta y media de las microcuencas, las que prevén la protección/conservación de las fuentes de agua y áreas de recarga hídrica a través de cerramientos, la identificación de los acuíferos, la delimitación del área de recarga hídrica y su protección (cerramiento con postes o árboles en pie), la forestación/reforestación, y desarrollo de prácticas de manejo de suelo que favorezcan la infiltración del agua en el subsuelo, la cosecha del agua a través de atajados, reservorios y mini-represas, y la mejora en la conducción, distribución y aprovechamiento del agua en la parcela y/o sistema de agua potable. Cada ARENA requiere de un profundo proceso de concertación para lograr acuerdos comunales como los ARAS (Acuerdos Reciprocos por el Agua), así como de la institucionalidad y normatividad municipal en la inclusión de acciones de protección de zonas de recarga, fuentes de agua y espacios de captura, en todos los proyectos de inversión, independientemente de su fuente de financiamiento y normas municipales de protección de fuentes de agua.

En la microcuenca de Laka Laka (Tarata, Cochabamba) y su área de riego los conflictos por el agua comenzaron a partir del 2002 cuando los derechos de agua previstos por el sistema de riego no abastecieron ni a los regantes ni a los usuarios de agua potable. La represa de Laka Laka construida en 1993 debía proveer agua suficiente para el sistema de riego. Al 2012, un 50% de su capacidad de almacenamiento se encuentra sedimentada. La mancomunidad del **Caine** realizó intensos procesos de negociación entre la Asociación de Regantes, el comité de agua potable de Tarata y el organismo de gestión de la microcuenca (OGC). El fortalecimiento institucional y la conformación de una Plataforma del Agua del sistema Laka Laka fue el espacio en el cual se abordaron y se establecieron mecanismos de negociación y acuerdos para una distribución del agua de acuerdo a los derechos establecidos. Con el propósito de reducir la degradación de la cuenca y el aporte de sedimentos a las represas se desarrollaron acciones de forestación, zanjas de infiltración, manejo de suelos que contribuyan adicionalmente a garantizar la seguridad alimentaria de las familias de la cuenca. El GAM de Tarata y Arbieta junto con el OGC son los responsables de promover la gestión de las cuencas en una perspectiva de mediano y largo plazo.

La gestión comunitaria en el **Norte de Potosí** como mecanismo para la recuperación de las tierras y el uso eficiente del agua en cuencas, ha tenido efectos importantes en razón a su amplia base participativa comunal, la realización de concursos comunales de manejo y conservación de suelos, y la formación de promotores locales<sup>97</sup>, todos ellos articulados en comités de microcuenca (organismos de gestión de cuencas) como espacio de concertación, discusión y resolución de sus problemáticas socio-ambientales. Los concursos familiares y comunales<sup>98</sup> en microcuencas permitieron primero el involucramiento y apropiación por parte de las familias campesinas en el cuidado y manejo sostenible de sus bases productivas, con la perspectiva de garantizar su seguridad alimentaria y reducir la degradación de sus recursos naturales. En segunda instancia, contribuyeron a la identificación de buenas prácticas para un

<sup>97</sup> La práctica de promotores locales puede ser revisada en Bolivia con los Yapuchiris (apoyada por la Cooperación Suiza a través del programa PROSUCO) y en Perú con los Kamayoq (apoyado por la Cooperación Suiza a través del programa MASAL)

<sup>98</sup> Versiones del 2010 al 2012

## SUSTAINABLE SERVICES

### Government, Decentralisation & Governance

mejor acceso al agua y tierras de las áreas de cultivo. A través de la aplicación de este enfoque, las comunidades, en forma concertada, recuperaron tierras agrícolas, conservaron sus fuentes de agua y áreas de recarga de acuíferos y mejoraron sus prácticas agropecuarias, logrando mayor productividad y mejores ingresos, y promoviendo el involucramiento de la familia (mujeres, jóvenes y niños) en todo el proceso. La aplicación de este sistema de gestión basado en el manejo y conservación de suelos y aguas logró una adecuada sensibilización y apropiación de los productores, quienes han iniciado procesos de incidencia política con sus gobiernos locales y centrales campesinas orientados a ampliar sus áreas de cultivo y diversificar su producción.

En la siguiente tabla comparativa resumimos los los modelos de gestion que aplicaron en manera diferenciados los cuatro ámbitos de la gobernanza :

**Tabla 1: Comparación de los Modelos de Gestión presentados**

Modelos de gestión	Gestión adaptativa de agua y praderas en microcuencas	Gestión, manejo y protección de fuentes de agua en cuencas	Manejo y conservación de suelos y agua y resolución de conflictos en microcuencas	
Mancomunidad	MM Héros de la Independencia	MM Chuquisaca Centro	MM Caine	MM Norte Potosí
Objetivo	cosecha y uso eficiente del agua y praderas para el fortalecimiento de ganadería camélida con enfoque de cuenca.	Manejo, protección y conservación de vertientes y áreas de recarga hídrica en las cabeceras de microcuencas.	Restauración ecológica y ambiental de la cuenca (forestación, recuperación de tierras agrícolas, protección de áreas de recargas de acuíferos y conservación de fuentes de agua.)	
Logros	Entre 2011 y 2014 se implementaron 14 modelos de gestión adaptativa del agua y praderas en microcuencas, que en conjunto lograron una protección de 18 fuentes de agua, mejoramiento y construcción de 6 sistemas de cosecha de agua, 50 has. de protección de laderas, mejoramiento de 22 sistemas de microriego, recuperación y conservación de 99.5 has. de praderas nativas y establecimiento de 102 has. de forraje para ganado camélido (en total aprox. 153 ton de avena, cebada y alfalfa). Conformación de un Comité de Gestión de la microcuenca de Laka Laka.	Los ocho municipios que conforman esta mancomunidad establecieron 24 ARENA que en conjunto lograron el cerramiento de 771 has de recarga hídrica, beneficiando a 758 familias de 14 comunidades en 10 microcuencas.	A impulso del CGMLL y de promotores formados, entre 2011 y 2014 se llegó a 344 familias campesinas de 12 comunidades recuperaron y habilitaron 40 has. De tierra agrícola en laderas. Forestación de 15 has. Mejoramiento de 35 sistemas de microriego. Conservación de 26 fuentes de agua. Conformación de una plataforma de concertación sobre el sistema de riego Laka Laka.	Realización de cinco concursos desde el 2007 al 2014 con participación de más de 3000 familias de 274 comunidades en 28 microcuencas. Forestación de 235 has. de especies nativas y exóticas. Habilidadación de 300 has. de tierras agrícolas en ladera. Recuperación y protección de 200 vertientes de agua.
Estrategia/Herramientas	Planificación participativa comunal Percepción local del clima. Revalorización de saberes locales. Formación de promotores locales.	Áreas de Reserva Natural de Agua (ARENA), Normas comunales, plan de manejo del área de recarga hídrica, estatutos y normas de operación y mantenimiento de los sistemas de agua.	Plataforma de concertación del agua Escuelas de campo. Espacios de concertación. Planes de ordenamiento comunal	Comites de microcuenca Planificación por microcuenca Concursos campesinos. Promotores locales
Dificultades	compromisos de contraparte familiar comunal ..  Corresponde a un área protegida Disminucion de las fuenets de agua	Celos institucionales. Diferencia de tiempos entre la planificación y la gestión de acuerdos y compromisos.	mas del 80% con niveles altos de erosion de los suelos Pobreza extrema de las las familias y las comunidades Influencia de la actividad minera . Dificultad en la concurrencia de niveles del estado. Migracion elevada y conflictos latentes	

## SUSTAINABLE SERVICES

### Government, Decentralisation & Governance

	Praderas naturales (bofedales) Suelos pobres con bajos nutrientes.		socioambientales Dificultad de trabajar en la concurrencia de diferentes actores	
Elementos clave	Participación comunitaria. Crianza y cosecha de agua, muy apreciada por el incremento en la disponibilidad del agua. Manejo eficiente de agua implica agua disponible de manera efectiva y equitativa. Integralidad de acciones a partir de necesidades locales. La gestión del agua y recursos naturales en microcuencas contribuye a la mejora de un rubro productivo rentable (ganadería camélida).	Articulación a través de la mancomunidad con actores locales, departamentales y nacionales (concurrencia entre niveles). Conocimiento y experiencias previas (instancia líder reconocida por los municipios)  Complementación y protección de infraestructuras mayores como presas con la gestión y protección de la cuenca de captación. Apropiación de destinatarios y compromiso con el y mantenimiento. Inversión pública concurrente Aplicación de normas locales y acuerdos y compensación a afectados.	Participación activa de las familias y comunidades campesinas. Liderazgo de la asociación de camelidos. Coordinación y concurrencia liderada por el Gobierno Municipal.	La recuperación de tierras consolidada y asegura la seguridad alimentaria a nivel familiar  Concursos campesinos motivan la participación, apropiación y empoderamiento local Incentivos como semillas, insumos agrícolas y otros son adecuados al contexto y motiva la replicación de las prácticas Participación activa de bases campesinas. La gestión de cuencas como mecanismo para garantizar la seguridad alimentaria. Espacios de concertación para la resolución pacífica de conflictos vinculados a la gestión de la cuenca

Elaboración propia

Entre las principales lecciones aprendidas de estas cuatro experiencias podemos mencionar:

1. El **liderazgo y apropiación del enfoque de gobernanza y gestión del agua en microcuencas** por parte de los actores locales (campesinos, productores) y sus municipios (a través de las mancomunidades de municipios) permiten cambios que contribuyen a una mayor sostenibilidad en la consolidación de la gestión integral del agua y los recursos naturales y el desarrollo de inversiones más sostenibles en agua y cuencas.
2. La construcción de espacios de coordinación, concertación y consenso para la **gestión compartida y corresponsable** del agua y recursos naturales en cuencas son importantes. La conformación de plataformas interinstitucionales locales, comités de microcuencas, organismos de gestión de cuencas, contribuyen en el fortalecimiento organizativo de la comunidad y el empoderamiento en relación a sus derechos y obligaciones en el uso y aprovechamiento del agua y otros recursos naturales (ej. suelo, bosques y pasturas) y su necesidad de articulación con el gobierno local y su anclaje en organizaciones existentes (subcentral, central campesina).
3. Para que la gestión integral de los recursos hídricos en cuencas sea sustentable, deben ejecutarse acciones que permitan obtener beneficios tanto en el ámbito productivo agropecuario como en el ámbito ambiental con enfoques de resiliencia y reducción del riesgo de desastres. Las experiencias desarrolladas por las mancomunidades en cuencas y microcuencas se sintetizan en dos grupos de acciones. Un grupo orientado a usar y aprovechar los recursos naturales (en la perspectiva de lograr un desarrollo económico local a través del incremento de su producción agropecuaria) presentes en la

## SUSTAINABLE SERVICES

### Government, Decentralisation & Governance

microcuencas y otro grupo orientados a manejarlos (conservación, protección, restauración, etc.) con el fin de lograr el “vivir bien” y en una perspectiva de una gestión integral de la microcuenca.

4. Queda claro que los técnicos (municipales, mancomunidades o de instituciones de apoyo) deben asumir otras actitudes y manejar otros conceptos diferentes a los tradicionales. En lugar de llevar paquetes de soluciones, tendrán que asumir el **papel de facilitador en la asistencia técnicas y servicios de extensión**, lo que implica fundamentalmente, prestar apoyo a las comunidades de la microcuenca para que ellos puedan organizarse de acuerdo a su propio interés en coordinación con su gobierno local y otros actores estratégicos.
5. La gestión del **conocimiento** es fundamental para recoger lecciones aprendidas de los procesos de este tipo de intervenciones, y promover la re-valoración del conocimiento local del manejo comunitario del agua y las tierras en sus territorios, y la aplicación de innovaciones para un uso más eficiente del agua y del desarrollo de medidas para el mantenimiento de las acciones por parte de los propios actores locales, así como para la incidencia en políticas públicas.
6. Finalmente una última lección aprendida es que el “**cómo hacer**” importa mucho más que el “**qué hacer**”. Las recetas o la tecnología para solucionar un problema (dependiendo su costo y calidad) son fáciles de encontrar. Pero lograr un acuerdo social para implementar cualquier tipo de medida que puede generar vaya a cambiar la situación establecida es muy complicado. Muchas acciones de desarrollo han quedado en lo que se llama “elefantes blancos” puesto que se decidió implementar una medida de manera unilateral y sin contar con la apropiación de los actores locales.

### Conclusions and Recommendations

La gobernanza del agua y recursos naturales en cuencas, busca procesos de acompañamiento, innovación, acuerdo y consenso entre los municipios y las comunidades que habitan las microcuencas para un mejor uso y aprovechamiento del agua y recursos naturales y que además contribuyan a cambios positivos en sus medios de vida y generación de ingresos. Es evidente que en todas partes se hace gestión integral del agua, pero lo novedoso de esta práctica es la forma en la que diversos actores locales lo han implementado. De manera general se puede concluir que:

1. La gobernanza del agua en cuencas implica tomar decisiones conjuntas entre todos los actores de la cuenca, tanto los actores locales, sector público y privado y por lo tanto es necesaria la participación efectiva, la coordinación interinstitucional para la articulación y concurrencia, la comunicación efectiva y la gestión de la información.
2. Para la consolidación de la gobernanza en cuencas es necesaria la motivación generada por la satisfacción de las necesidades y la posibilidad de todos los actores de incidir directamente en los cambios que se requieren para mejorar la calidad de vida de las personas (destinatarios) dentro de una microcuenca.
3. El agua está enmarcada en un entorno territorial e institucional con situaciones conflictivas, principalmente en la competencia de los usos, sea por ejemplo para la producción como para el consumo. Vincula a los usuarios y las instancias públicas y privadas, por lo que todos estos actores deben participar en la búsqueda de soluciones, arreglos y alianzas. En este sentido, las experiencias muestran que a través de una adecuada organización se tomaron decisiones y acciones de manera incluyente y se redujeron y/o previnieron conflictos en torno al uso del agua.
4. Dadas las condiciones de las áreas que se presentaron, las acciones desarrolladas muestran que las medidas de protección en zonas de recarga hídrica y de tomas de agua bajo un enfoque GIRH por microcuenca han llegado a influir de manera positiva en la calidad de las aguas y la mejora de las tierras agrícolas. Además, se convirtieron en referente para el desarrollo de una normativa local para su promulgación como ordenanza o ley municipal, sirve inclusive como insumo para el desarrollo normativo departamental. Por el periodo de intervención y la magnitud de estas cuencas no se han podido desarrollar estudios más especializados (como por ejemplo estudios de balances hídricos).
5. Las técnicas participativas en la elaboración de planes comunales para el manejo de cuencas (ej. mapas parlantes, maquetas) fueron ampliamente usados con variados niveles de éxito. En las experiencias realizadas los procesos participativos funcionaron cuando hubieron propósitos comunes, es decir, que llegaron a interesar a la mayoría de la población en la microcuenca Laka Laka, también cuando el proceso participativo fue flexible y brindó un desarrollo de capacidades y empoderamiento ge-

## SUSTAINABLE SERVICES

### Government, Decentralisation & Governance

- nuino, donde las comunidades vieron beneficios económicos y estuvieron empoderados, ellos estuvieron dispuestos a trabajar en las prácticas de conservación de suelos y aguas en microcuencas.
6. La integración de comunidades y sus estructuras sociales en comités de microcuencas u organizaciones similares conducen a una mejor participación, cohesión y unidad. Este tipo de organizaciones brindaron a sus miembros un mejor control y gestión de sus recursos. En tal sentido, se evidenció que a mayor participación de los destinatarios con un enfoque de interculturalidad (identificación, diseño/planificación, ejecución, evaluación), se logran mejores niveles de apropiación y sostenibilidad de las acciones de GIRH.
  7. Los arreglos internos en las comunidades para racionar el agua y priorizar los usos, a partir de la demanda de las familias y la disponibilidad en las fuentes, deben ser conservados y potenciados ya que son un espacio endógeno de organización e institucionalidad local de gran valor.
  8. Para tener efectos sostenibles, se trabajó en diferentes escalas: local/comunal, microcuencas, municipal y regional. En este sentido es relevante contar con acciones tangibles a nivel local (familiar, comunal); a nivel de microcuencas, la conformación de comités con un reconocimiento local fue fundamental; a nivel de cuenca, las alianzas estratégicas (articulación y concertación) entre los actores públicos (municipios y gobernaciones) facilitaron el escalamiento de incidencia política a nivel departamental y nacional.
  9. Estos procesos toman tiempo para consolidarse. Es necesario acompañar los mismos para que puedan ser sostenibles.

Las experiencias desarrolladas generaron una serie de recomendaciones entre las que mencionamos las siguientes:

1. Las experiencias demuestran que el enfoque de manejo integral de microcuencas puede crear las sinergias requeridas para el manejo sostenible de los suelos, la adaptación al cambio climático, la conservación de los recursos hídricos y el uso y aprovechamiento de los recursos naturales, lo que mejoraría los medios de vida de las familias campesinas. Incentivos para la participación se deben centrar en generar flujos de ingreso a través de mejor uso de sus recursos naturales, diversificación agrícola, acceso a mercados, mejorando sus fuentes y acceso al agua.
2. La planificación no debe estar aislada de las acciones prácticas y aprendizaje. El desarrollo y financiamiento de un grupo de acciones demostrativas sobre manejo de cuenca colocan los principios de la GIRH en la práctica. Por lo tanto, es importante trabajar para entregar resultados en el terreno y usar estas lecciones para mejorar las políticas (ej. municipales), planes (locales) y normativas.
3. No hay una receta para la GIRH. Se debe trabajar con los actores (públicos, privados y locales) para adaptar los principios de la GIRH a las realidades del nivel local e institucional, a través de acciones demostrativas que sean flexibles y que se adapten e innoven en la medida en que avanza.
4. La implementación de la GIRH requiere de una gobernanza del agua. La creación de plataformas de actores (multiactores) que se reúnen para transparentemente acordar y definir los derechos y responsabilidades en la gestión del agua es importante (ej. plataforma departamental de cuencas, plataformas regionales de recursos hídricos, comité de microcuencas, comités de regantes y agua potable, etc.) para resolver conflictos sobre su uso y aprovechamiento.

### References

- Akmouch, A. 2012. Water Governance in Latin America and the Caribbean: A Multi-Level Approach. OECD. Regional Development Working Papers. France.
- Cabrera, P. 2011. Sistematización de Procesos de Gobernanza Interescalas para la Gestión de los recursos hídricos. El caso de la cuenca alta del río Guayllabamba. Fundación Futuro Latinoamericano. Ecuador.
- CONCERTAR - INTERCOOPERATION 2010. Una propuesta para la gestión regional: la regionalización del país a partir de las mancomunidades. Bolivia.
- Córdova B. G., Aguilar, R. M., & Peña M, S. 2006. Participación ciudadana y gestión del agua en el valle de Juárez, Chihuahua. Región y Sociedad.
- Delgado, L. E., Bachmann, P. L., & Oñate, B. 2007. Gobernanza Ambiental: una estrategia orientada al desarrollo sustentable local a través de la participación ciudadana. Ambiente y Desarrollo.



## SUSTAINABLE SERVICES

### Government, Decentralisation & Governance

- Dourojeanni. A. 2010. Protocolos, lineamientos, definiciones aplicables a la Gestión integrada de recursos hídricos por cuenca hidrográfica. Elaborada para el SENAGUA de Ecuador. Ecuador
- FAO. 2011. El estado de los recursos de Tierras y Aguas del Mundo para la alimentación y la agricultura. Como Gestionar los sistemas en peligro. Italia.
- FPS. 2012. Guía técnica – didáctica para la aplicación de los principios de la Gestión Integrada de los Recursos Hídricos. Fondo de Inversión Productiva y Social. BID. PROAPAC/ GIZ. Bolivia.
- Gentes, I. 2003. Gestión comunitaria de propiedad hídrica y manejo de conflictos. Participación social y gestión del agua dulce. Cuadernos PROLAM/USP.
- Hendriks. J. 2009. Conceptos e instrumentos para la gestión integrada de cuencas hidrográficas – La experiencia de la Autoridad Autónoma de Cuenca Hidrográfica Chira-Piura. Folleto 1. Perú.
- Heredia. L. 2013. Sistematización de experiencias en Protección de Fuentes de Agua. Mancomunidad Chuquisaca Centro – PROGRO/GIZ - CONCERTAR/HELVETAS Swiss Intercooperation. Bolivia.
- Indij. D. 2012. Serie Casos de Estudio: Edición 2011. El Impacto del Desarrollo de Capacidades en la Gestión Integrada de los Recursos Hídricos en América Latina LA-WETNET Argentina.
- Kooiman, J. 2004. Governing as governance. Instituciones y Desarrollo N° 16, Institut Internacional de Governabilitat de Catalunya, Barcelona, 171 - 194.
- MASAL. 2011. Efectos e impactos de proyectos de gestión integrada de recursos hídricos, con enfoque de desarrollo territorial en zonas de pobreza de la sierra del sur del Perú. Perú.
- Maza C. 2012. Memoria Foro Andino del Agua 2011, CONCERTACION, CONSORCIO ANDINO DEL AGUA, IPROGA, JUSTICIA HIDRICA, Perú.
- Mejía. M; Sotomayor. M. 2011. Nosotros(as) los Kamayoq. MASAL, Perú.
- Ojeda, L. 2005. Gobernabilidad en la conservación de los recursos naturales. La Florida USA: Universidad de La Florida.
- Osinde, R. 2008. Review of existing concepts of water governance and an analysis of pro-poor approaches in UN-HABITAT interventions. United Nations Human Settlements Programme.
- Pando, E. Rude E, y Lorini. L. 2012. Sistematización del avance de la política sectorial de cuencas en el Marco de la Declaración de Paris. (Sector Wide Approach / Enfoque Sectorial). Programa de Apoyo Sectorial al Plan Nacional de Cuencas – ASPNC. Bolivia.
- PNC. 2007. Plan Nacional de Cuencas. Marco Conceptual y Estratégico (versión 01), Bolivia
- PNC. 2012. Plan Nacional de Cuencas. Marco Conceptual y Estratégico (versión 02), Bolivia
- PROAGRO. 2010. Experiencias de la cooperación alemana en al manejo integral de cuencas y la gestión integral de los recursos hídricos en Bolivia. GTZ y DED. Bolivia.
- PROMIC. 2004., El manejo integral de cuencas en el desarrollo local: Un proceso de construcción y aprendizaje. Experiencias en la cordillera del Tunari. Bolivia.
- PRONAMACHCS. 2005. Gestión participativa de los Recursos Naturales para el Desarrollo Rural Sostenible. PRONAMACHS. Perú.
- PROTOS, CEDIR, CENDAS. 2010. Yakuñan. Participación y Gestión Concertada de microcuencas. Ecuador.
- Rodríguez L. Gutierrez, R. 2012. Memoria de lecciones aprendidas de las Asistencia Técnica al Apoyo Sectorial al Plan Nacional de Cuencas: Hacia una gestión integral del agua en Bolivia. Bolivia.
- Rodríguez T, 2012. Diagnóstico del Agua en las Américas. Red interamericana de academias de ciencias foro consultivo científico y tecnológico. DF-México.
- Rogers, P. Hall, A. 2003. Effective Water Governance. TEC Background Papers. GWP
- Saavedra C. 2010. El manejo, protección y conservación de fuentes de agua y recursos naturales. Guía del capacitador y cartilla educativa. Un aporte al III Concurso Fiesta Nacional del Agua (Mancomunidades de municipios andinos y subandinos de Bolivia). Bolivia.
- Saavedra, C., & del Castillo, M., et al. 2013. Procesos de concertación local para la gestión y protección de fuentes de agua en cuencas altoandinas: Estudio de caso en mancomunidades de municipios en Bolivia. Helvetas Swiss Intercooperation.
- Saavedra, C., & Huanca M. J. 2012. 1ra Fiesta Nacional del Agua: Experiencia de un proceso de gestión social del agua en microcuencas. La Paz, Bolivia. Helvetas Swiss Intercooperation.
- Sadoff, C.; Muller, M. 2010. La gestión del agua, la seguridad hídrica y la adaptación al cambio climático: Efectos anticipados y respuestas esenciales. Global Water Partnership. TEC Background Papers N 14.

## SUSTAINABLE SERVICES

### Government, Decentralisation & Governance

- Sotomayor, M. Choquevilca, W 2011. La gente, la gestión del agua y el territorio. MASAL. Peru.
- UNESCO. 2009. The United Nations World Water Development Report 3. Water in a changing world. France.
- UNESCO, 2012. The United Nations World Water Development Report 4. Volume 1. Managing Water under Uncertainty and Risk. France.
- Veith, C. 2012. ¿Why invest in Sustainable Mountain Development?. FAO. Italy.
- Vogel, A.; Rojas, J & Sallo, C. 2005. Participar y concertar para una gestión sostenible de los recursos naturales en microcuencas altoandinas del Perú. PRONAMACHCS. Peru.
- Wilk, J.; Wittgren, H & 2009. Adapting Water Management to Climate Change. Swedish Water House Policy Brief. SIWI.

SUSTAINABLE SERVICES

Government, Decentralisation & Governance

---

## Le renforcement des capacités et de la gouvernance locales au service de la durabilité des services d'eau en région rurale- étude de cas du projet Burkina Faso de One Drop

---

Type: Article court

**Auteurs** Marie-Anne Champoux-Guimond, *Conseillère senior, Eau et gestion des savoirs, One Drop*  
550 ave. Beaumont, suite 400, Montréal, Qc, Canada  
514-723-7646, poste 6799  
[Marie-anne.champoux-guimond@onedrop.org](mailto:Marie-anne.champoux-guimond@onedrop.org)

### Abstract/Résumé

Assurer la durabilité des services constitue un enjeu majeur dans le secteur WASH, particulièrement en milieu rural. Sur la base d'une approche systémique déclinée en trois volets d'intervention et baptisée *A•B•C de la Durabilité*<sup>99</sup>, ONE DROP<sup>TM</sup> développe des projets intégrés ancrés dans les communautés, dans l'objectif de répondre durablement aux problématiques d'accès à l'eau et à l'assainissement des populations. Initié en 2012 dans la région des Cascades et des Hauts-Bassins, le Projet Burkina Faso mise sur le renforcement des capacités et de la gouvernance locales comme vecteur de durabilité. Les activités déployées ont permis d'accroître de façon importante l'accès aux services dans la zone d'intervention tout en rehaussant la qualité de ceux-ci (fonctionnalité, fiabilité, qualité de l'eau, etc), et l'approche participative privilégiée a favorisé l'appropriation du projet par les communautés et les acteurs locaux.

### Introduction

Le Burkina Faso figure parmi les pays les plus démunis du monde, se classant 183/187 selon l'Indice de développement humain (IDH) (PNUD, 2015). La vaste majorité de la population vit de l'agriculture, dont elle tire des revenus inférieurs à deux dollars par jour. Parmi les facteurs perpétuant le cercle vicieux de la pauvreté, le manque d'accès à l'eau potable et à l'assainissement constitue un obstacle majeur au développement humain et socio-économique. Il existe une forte disparité entre régions urbaines et rurales, ces dernières accusant un retard important tant au niveau de l'accès aux services que de la durabilité de ceux-ci. De fait, 24% de la population rurale est privée d'accès à une source d'eau améliorée, et 93% n'a pas accès à des installations sanitaires adéquates (JMP, 2015).

Cette situation découle de facteurs multiples, parmi lesquels certaines conditions naturelles telles que la faible disponibilité des ressources en eau renouvelables (745m<sup>3</sup>/personne/an (FAO, 2014)) résultant de précipitations insuffisantes et d'une sécheresse endémique. Néanmoins, plusieurs facteurs d'origine anthropique contribuent aussi à la problématique d'accès à l'eau. Ainsi, d'importantes lacunes existent au niveau de la gestion des ressources hydriques, et l'intensification des activités agricoles et industrielles contribue à leur dégradation et à l'augmentation des conflits d'usages. En outre, le contexte local se caractérise par une coopération déficiente entre les différents acteurs, dont les capacités institutionnelles,

---

<sup>99</sup> ONE DROP et *A•B•C de la Durabilité* sont des marques de commerce détenues exclusivement par la Fondation One Drop, ce qui n'a pas pour effet d'empêcher des tierces parties de reproduire les méthodes ou processus, mais seulement d'en utiliser le nom. Par ailleurs, One Drop détient les droits exclusifs sur tous les produits d'Art Social développés dans le cadre de ses projets/programmes. Néanmoins, des autorisations non-exclusives sont octroyées aux partenaires et gouvernements qui souhaitent en faire usage, dans l'objectif de favoriser le partage des bonnes pratiques et la diffusion des connaissances. Toute demande en ce sens peut être transmise à One Drop ([contact@onedrop.org](mailto:contact@onedrop.org)).

## SUSTAINABLE SERVICES

### Government, Decentralisation & Governance

techniques et de gestion sont limitées. Finalement, les outils analytiques et de suivi s'avèrent souvent inadéquats, obstacle additionnel à la mise en place de services d'eau, d'assainissement et d'hygiène (WASH)<sup>100</sup> abordables et durables.

Assurer la durabilité des services constitue donc un défi majeur au Burkina Faso comme dans l'ensemble du secteur WASH, qui se caractérise globalement par un taux de non-fonctionnalité des systèmes d'eau variant entre 30 et 50% (Davis, 2016). Plusieurs conditions

doivent être réunies pour parvenir à résoudre cette problématique, parmi lesquelles: l'amélioration de la gestion communautaire pour rehausser la qualité des services offerts; la mise en place d'un système efficace de suivi, d'entretien post-construction et de recouvrement des coûts; l'harmonisation des actions du secteur WASH avec les politiques gouvernementales; la coordination améliorée entre les différents acteurs du milieu; le renforcement des capacités des autorités locales (Moriarty et al., 2013); l'adoption par les populations de bonnes pratiques en matière de gestion de l'eau, l'assainissement et l'hygiène. Cet enjeu est donc au cœur des initiatives déployées par ONE DROP<sup>TM</sup> <sup>101</sup>, et contribuer à mettre en place les conditions favorables au développement de services WASH durables constitue l'axe central du Projet Burkina Faso.



### Description de l'étude de cas – Approche ou technologie

Initié en 2012 dans cinq communes rurales de la région des Cascades et des Hauts-Bassins (Péni, Toussiana, Banfora, Moussodougou, Bérégadougou), le Projet Burkina Faso<sup>102</sup> vise ainsi à accroître l'accès durable à l'eau, l'assainissement et l'hygiène (WASH). Développé suivant une approche systémique baptisée *ABC de la durabilité*, le projet repose sur trois composantes complémentaires : l'accès aux services (« A » pour *access*), le changement de comportements à travers l'Art Social (« B » pour *behavior*) et l'accès au capital (« C » pour *capital*) pour le développement de solutions abordables facilitant l'accès aux services WASH. Afin de répondre aux problématiques spécifiques caractérisant la zone d'intervention, le Projet mise sur le renforcement des capacités et de la gouvernance locales comme vecteur privilégié de durabilité. Déployé sur une période de cinq ans il contribuera, à terme, à l'amélioration des conditions de vie de plus de 75 000 personnes.

Suivant une approche de développement endogène visant l'enracinement du projet dans les communautés et son appropriation par celles-ci, One Drop s'est associée à plusieurs organisations et institutions locales pour réaliser les activités des trois volets d'intervention. Leur connaissance du milieu, du contexte et des pratiques locales est un atout inestimable permettant le développement d'interventions ciblées, ancrées dans les communautés et adaptées aux besoins des populations. À ces acteurs-clés viennent s'ajouter des partenaires internationaux et nationaux renommés qui, aux côtés de One Drop, assurent la coordination, la mise en œuvre et le suivi des activités : Oxfam-Québec, l'Espace culturel Gambidi, Mise au Jeu, IRC et la Fédération des Caisses populaires du Burkina Faso. Le développement et la mise en œuvre du Projet Burkina Faso repose donc sur les efforts concertés d'une équipe multidisciplinaire formée de professionnels qualifiés relevant de One Drop et d'Oxfam-Québec, en plus des ressources additionnelles

<sup>100</sup> L'acronyme anglais WASH est employé dans le présent article compte tenu de son utilisation répandue dans le secteur, tant dans les publications en anglais que celles en français et en espagnol.

<sup>101</sup> One Drop – une initiative fondée de Guy Laliberté, fondateur du Cirque du Soleil<sup>TM</sup> – est un organisme sans but lucratif créé en 2007 à Montréal, Canada, dans l'objectif d'assurer que tous aient accès à l'eau, aujourd'hui et pour toujours.

<sup>102</sup> Afin de simplifier, nous utilisons ici « Projet Burkina Faso » pour référer au projet, dont le nom complet est *Projet Eau dans le Bassin de la Haute-Comoé au Burkina Faso* (PEHC).

## SUSTAINABLE SERVICES

### Government, Decentralisation & Governance

mises à contribution par les organisations partenaires.<sup>103</sup> Le projet est doté d'un budget global de 7,8 millions CAD (environ 6 millions USD)<sup>104</sup>, financé en majeure partie par One Drop et la Conrad N. Hilton Foundation.<sup>105 106</sup>

#### Approche participative et renforcement des capacités

L'intervention a été développée et exécutée selon une méthodologie participative valorisant l'implication active des divers acteurs (partenaires, populations, autorités locales, etc) au processus décisionnel, par le biais d'assemblées citoyennes, de consultations et de séances de médiation destinées à assurer un dialogue continu et à obtenir la rétroaction des usagers quant à l'impact social du Projet. De plus, reconnaissant que la professionnalisation de la gestion communautaire constitue une condition essentielle à l'amélioration des services, le renforcement des capacités des acteurs locaux est une composante cruciale du projet. L'objectif est de permettre aux autorités locales régionales d'accroître leur leadership et de jouer pleinement leur rôle dans la planification, le suivi et la réglementation entourant la prestation des services pour optimiser la qualité de ceux-ci (Moriarty et al., 2013).



Une collaboration étroite a ainsi été établie avec les autorités communales, qui ont notamment été appuyées dans l'élaboration de leur Plan communal de développement pour l'eau potable et l'assainissement, un outil précieux leur permettant de cerner avec plus de précision les besoins des populations et de mobiliser les ressources nécessaires à l'amélioration de l'accès aux services WASH. Les communes ont également bénéficié de plusieurs sessions de formation répondant à des enjeux spécifiques, notamment pour leur permettre de mieux maîtriser les principes de la Gestion intégrée des ressources en eau de même que les différentes composantes de la Réforme nationale de l'eau et de l'assainissement. Cela, dans l'objectif d'harmoniser leur action avec les politiques et stratégies gouvernementales tout en améliorant leurs capacités de plaidoyer en faveur d'une meilleure attribution technique et budgétaire pour la mise en œuvre locale de ces politiques. Une dynamique d'étroite collaboration a également été développée avec le Comité local de l'eau Haute-Comoé, organisme responsable d'assurer la synergie entre les acteurs au niveau régional, qui a été impliqué dans l'ensemble des activités en plus de profiter d'un appui pour renforcer ses capacités institutionnelles. Cette nouvelle dynamique de collaboration active a permis d'assurer la pleine intégration des actions du Projet dans la perspective de la *Réforme nationale*, en adéquation avec l'objectif gouvernemental de renforcer le leadership des municipalités, par le biais du transfert de ressources et de compétences, pour qu'elles assument pleinement la gestion des services d'eau. Le contexte national favorable, marqué par la mise en œuvre de la Réforme, la décentralisation et la priorité accrue accordée au secteur WASH dans son ensemble a donc

<sup>103</sup> Au sein de One Drop, l'équipe dédiée au Projet Burkina Faso est composée des personnes suivantes : Directeur exécutif- Programmes internationaux; Directrices des opérations; Chargée de programmes – Afrique; Directrice Suivi, Évaluation et Apprentissage (SEA); Conseillère senior – Eau et gestion des savoirs. L'équipe travaillant dans la zone d'intervention et relevant d'Oxfam-Québec est pour sa part composée des personnes suivantes : Directrice de projet; Coordonnateur- microfinance; Technicien SEA; Assistants techniques (2); Techniciens intercommunaux (2). L'équipe peut également compter sur le support d'une équipe administrative et logistique (comptable, adjoint administratif, chauffeur, garde de sécurité) pour assurer le bon déroulement des opérations sur le terrain.

<sup>104</sup> Le budget est approximativement réparti de la façon suivante : 45% est consacré au volet « A », 27% au volet « B », 12% au volet « C » et 5% au Suivi, évaluation et apprentissage. Les frais de gestion s'élèvent pour leur part à 11% du budget global de projet.

<sup>105</sup> Parmi les partenaires financiers additionnels du Projet, mentionnons : le Gouvernement du Burkina Faso; le Réseau des Caisses populaires du Burkina Faso; la Caisse d'économie solidaire Desjardins; la Fondation Prince Albert II de Monaco; Rotary International.

<sup>106</sup> La plupart des projets mis en œuvre par One Drop s'échelonnent sur une durée de cinq ans et sont dotés d'un budget de 5 à 10 millions USD couvrant les trois volets d'intervention sur lesquels repose l'approche *A • B • C de la durabilité*.

## SUSTAINABLE SERVICES

### Government, Decentralisation & Governance

constitué un facteur-clé de succès. Le Projet a ainsi pu s'appuyer sur la mobilisation existante des instances locales pour œuvrer au renforcement des nouvelles structures de gestion mises en place, assurant la cohérence des activités avec les priorités gouvernementales, en étroite collaboration avec les responsables politiques.

Les partenaires locaux ont eux aussi profité d'activités de formation variées visant le renforcement de leurs capacités techniques et leur connaissance du secteur WASH. Globalement, un dialogue constructif a été instauré entre les différents acteurs tout au long du développement et de l'exécution du projet pour assurer une collaboration plus



efficiente entre tous, autre condition essentielle à la mise en place de services durables pour les populations.

### Amélioration de l'accès à l'eau et renforcement de la gouvernance locale (volet « A »)

Dans le cadre du volet « A » du projet Burkina Faso, la construction de 51 nouveaux puits et de 22 bornes-fontaines, la réhabilitation de 28 puits existants et l'extension des deux réseaux locaux d'approvisionnement ont permis à plus de 56 000 personnes dans 45 villages des cinq municipalités d'intervention d'accéder à une eau saine. En outre, 299 latrines familiales et 32 latrines institutionnelles (marchés, écoles, mosquées) ont été construites afin d'assurer l'accès des populations à des infrastructures sanitaires adéquates. 114 lavoirs et puisards ont aussi été bâtis et un système de collecte des ordures ménagères a été mis sur pied, deux activités qui ont permis d'améliorer de façon notable la propreté des lieux publics, au bénéfice des populations.<sup>107</sup>

Afin d'instaurer une gestion adéquate des infrastructures hydrauliques et d'assurer leur durabilité, le renforcement de la gouvernance locale est essentiel. Dans cette logique, différentes instances ont été mises en place et leur capacité à mobiliser l'ensemble des acteurs a été renforcée. Au niveau des communes, les Comités communaux de l'eau ont été créés pour assurer la supervision technique des infrastructures hydrauliques et appuyer le technicien communal responsable de l'entretien. Au niveau des villages, les Associations d'usagers de l'eau (AUEs) ont été constituées, formées et appuyées dans leur rôle de support direct aux utilisateurs et de contrôle du service public (équité, qualité, disponibilité, accessibilité). Finalement, les Comités de points d'eau (CPE) ont été établis pour veiller à l'entretien et l'utilisation adéquate des installations et sensibiliser les usagers à l'importance de manipuler avec soin les équipements, contribuant à réduire la fréquence des pannes et des bris d'équipement.

Assurer le suivi, l'exploitation et l'entretien préventif et curatif adéquat des infrastructures constitue ainsi l'un des facteurs-clés de durabilité, dont le financement doit être assuré en continu. Un système de recouvrement des coûts a ainsi été mis sur pied pour assurer la contribution des usagers à travers la collecte de frais d'utilisation. Les AUEs sont responsables de l'opérationnalisation du système et de la gestion globale des fonds recueillis auprès des ménages. Les frais sont établis en fonction des directives prévues par la *Réforme nationale* et le montant des cotisations est déterminé par les autorités communales. Afin d'assurer le bon fonctionnement du système, le renforcement des capacités joue ici encore un rôle

<sup>107</sup> Des informations complémentaires sur le Projet Burkina Faso sont disponibles sur le site de One Drop : <https://www.onedrop.org/fr/projets/>. Certaines informations contenues dans ce texte proviennent toutefois de documents de projets internes non-accessibles au grand public. Toute demande d'information peut toutefois être transmise à One Drop : [contact@onedrop.org](mailto:contact@onedrop.org).

## SUSTAINABLE SERVICES

### Government, Decentralisation & Governance

crucial qui distingue le Projet Burkina Faso d’initiatives similaires mises en œuvre dans la région. Le Projet a ainsi soutenu la formation des techniciens municipaux responsables d’appuyer les AUEs pour assurer l’opérationnalisation du système de recouvrement des coûts, et la collecte effective des tarifs auprès des usagers. En outre, l’importance revêtue par la contribution financière des ménages pour permettre l’entretien adéquat des infrastructures et garantir leur durabilité figure au nombre des messages-clés véhiculés à travers les activités de sensibilisation et de mobilisation des populations. Ici encore, les mécanismes mis en place sont donc parfaitement alignés avec la stratégie gouvernementale visant l’appropriation des services par les communautés, et permettent d’en assurer un suivi rigoureux en plus d’offrir soutien et encadrement à la population dans l’adoption de bonnes pratiques de gestion de l’eau et d’utilisation des équipements hydrauliques.

### **Sensibilisation des populations à la gestion durable des infrastructures et aux comportements responsables de gestion de l’eau, l’assainissement et l’hygiène (volet « B »)**

Au-delà des infrastructures, les populations jouent un rôle majeur dans la mise en œuvre de solutions pérennes aux enjeux de l’eau. S’inspirant de son héritage circassien, One Drop a choisi l’Art social<sup>108</sup> comme vecteur de sensibilisation pour favoriser l’adoption de comportements responsables de gestion des infrastructures et des ressources, gages de la durabilité des interventions. Des spectacles multidisciplinaires en langue locale (dioula) puisant à même la richesse culturelle de la zone, ont été créés pour porter des messages cruciaux tels l’importance de protéger les ressources hydriques et naturelles et le partage équitable de l’eau. Intitulés « Pour le retour de Ouhma<sup>109</sup> » et « Jli Ko ou la reconquête de l’eau », ces deux œuvres artistiques abordent respectivement les thématiques de la rareté hydrique et des responsabilités collectives liées à la gestion et la préservation de l’eau. De plus, 4 courts spectacles de « théâtre-débat »<sup>110</sup> ont été créés et déployés dans la zone d’intervention pour sensibiliser les populations aux enjeux liés aux pratiques inadéquates de collecte, transport et entreposage de l’eau, à la dégradation de la qualité de l’eau résultant de certaines activités humaines, au rôle des AUEs, à l’importance de la tarification et à la responsabilité collective dans l’assainissement des communautés.

Par ailleurs, des ateliers artistiques pédagogiques ont permis aux artistes locaux de développer ou perfectionner leur maîtrise de différentes disciplines liées aux arts de la scène (cirque, danse, conte, marionnettes, etc) dans l’objectif d’en faire des agents multiplicateurs au sein de leur communauté. Des activités éducatives fondées sur l’approche pédagogique « enfant par enfant » ont été dispensées dans les écoles pour sensibiliser les écoliers aux enjeux liés à l’eau et à l’environnement, et favoriser l’adoption de comportements responsables notamment à travers la formation de « clubs d’hygiène » dans chaque école participante. La diffusion de feuillets radiophoniques, la création de murales, la distribution d’outils pédagogiques (guides méthodologiques, recueils de contes, documentaire vidéo, etc) figurent également parmi les activités mises en œuvre dans le cadre du volet « B » du Projet. En abordant des problématiques ancrées dans les réalités locales, ces activités ont permis de mobiliser les gens et de leur donner confiance en leurs institutions faisant émerger une prise de conscience collective et une pensée critique face à ces enjeux. De plus, le renforcement des capacités des troupes artistiques locales, la formation des professeurs aux approches de sensibilisation innovantes et la mise sur pied de « clubs » formés d’écoliers assureront la présence dans les communautés d’ambassadeurs et d’agents culturels habilités à reproduire certaines activités, à transmettre leurs connaissances et à accroître la diffusion des messages-clés de sensibilisation.

<sup>108</sup> L’Art social peut être défini comme l’utilisation de différentes techniques artistiques pour répondre à des enjeux sociaux.

<sup>109</sup> Ouhma signifie « eau » en langue locale.

<sup>110</sup> Le Théâtre-débat est une forme théâtrale privilégiant l’interaction avec le public par une prise de parole partagée dans l’objectif de favoriser la responsabilisation et la conscientisation des populations.

## SUSTAINABLE SERVICES

### Government, Decentralisation & Governance



#### Soutien à l'entrepreneuriat et à la production locale (Volet « C »)

Offrir aux populations des opportunités économiques leur permet d'aspirer à une amélioration concrète de leurs conditions de vie. À travers la microfinance et l'éducation financière et entrepreneuriale, le Projet a contribué à stimuler l'économie locale (renforcement des moyens de subsistance, réduction de la migration saisonnière, développement de nouvelles filières, etc), à augmenter le potentiel d'inclusion financière des participants et à accroître leurs revenus par le

développement ou la consolidation d'activités productives. Les organisations et entrepreneurs participants ont bénéficié d'un soutien important, notamment pour le développement de leur plan d'affaires, grâce auquel plusieurs ont pu avoir accès au soutien des institutions financières traditionnelles. Les activités productives créées ou consolidées auront certainement des répercussions positives sur la dynamique économique locale.

#### Résultats principaux et leçons apprises

Le Projet Burkina Faso a contribué à l'amélioration concrète des conditions de vie des populations ciblées, qui peuvent désormais compter sur des services fiables leur assurant l'accès continu à une eau de qualité. Le taux d'accès à l'eau potable a progressé considérablement, passant de 62% (2012) à 80% (2015) dans la zone d'intervention. La distance à parcourir de même que le temps d'attente à la source ont été réduits de façon substantielle, allégeant pour les femmes et les filles le fardeau de la collecte de l'eau et leur permettant de s'investir dans différentes activités productives et éducatives. En outre, l'amélioration de la qualité de l'eau a permis de constater une réduction significative de l'occurrence des maladies diarrhéiques, particulièrement chez les enfants, ce qui se reflète notamment sur la productivité et l'assiduité scolaire. Les répercussions positives se font donc ressentir dans l'ensemble des communautés visées.

Par ailleurs, le système solide de gouvernance locale mis en place à travers le Projet permet d'assurer la gestion durable des infrastructures tout en instaurant une dynamique de collaboration positive entre l'ensemble des acteurs impliqués. Des mécanismes de dialogue efficaces ont été établis, qui ont contribué à une plus grande appropriation par les communautés de leurs responsabilités collectives dans la gestion de l'eau, et à un engagement renouvelé envers celles-ci. De plus, les différentes instances de gouvernance de même que le système de recouvrement des coûts ont permis d'assurer l'entretien continu des installations et la fiabilité de l'approvisionnement en eau. Le taux de panne observé dans l'ensemble de la zone d'intervention se limite ainsi à 7% comparativement à une moyenne de 12% au niveau national (MARHASA, 2016), ce qui témoigne de l'impact positif de l'intervention sur la qualité et la durabilité des services offerts.

Les activités artistiques de sensibilisation et de mobilisation du projet ont permis de rejoindre plus de 100,000 personnes dans la zone d'intervention. Des changements de comportements positifs de même qu'une plus grande cohésion au sein des communautés ont pu être observés, laissant entrevoir des bénéfices durables pour les communautés. À titre d'exemple, les cultivateurs vivant en bordure des rivières Béréga et Yanon ont modifié la configuration de leurs cultures afin de protéger la bande riveraine pour réduire l'érosion et préserver la qualité de l'eau. Dans la municipalité de Péni, les activités de sensibilisation de même que la mobilisation active des populations envers la gestion améliorée des ordures ménagères ont donné lieu à une amélioration notable de la propreté des lieux publics. Autant d'éléments qui permettront d'ancrer dans le temps l'impact du projet.



## SUSTAINABLE SERVICES

### Government, Decentralisation & Governance

Finalement, dans le cadre du volet « C », plus de 100 personnes ont bénéficié d'un micro-prêts pour encourager le démarrage ou l'expansion de petites entreprises, le taux de remboursement de 100% témoignant de la grande mobilisation des participants. Quatre périmètres maraîchers, quatre unités de transformation alimentaires et trois pépinières ont aussi été mis sur pied, contribuant à diversifier et soutenir la production agricole locale en plus de favoriser une plus grande inclusion des femmes dans l'économie productive. En outre, plus de 1000 personnes ont participé aux différentes activités de formation financière dispensées dans le cadre du projet, qui ont permis de renforcer leurs connaissances et aptitudes entrepreneuriales, atouts importants pour assurer le succès de leur entreprise.

Le Projet Burkina Faso est présentement en phase de consolidation jusqu'à la fin 2016, une étape cruciale pour renforcer les bénéfices des interventions et garantir leur prolongement au-delà de la durée du projet. Plusieurs activités supplémentaires ont été déployées afin de répondre à certains besoins spécifiques identifiés pendant la période de mise en œuvre, dans une logique d'amélioration continue des pratiques. Ainsi, des forages additionnels ont été réalisés pour réduire la pression exercée sur les infrastructures existantes en raison de leur utilisation assidue par un nombre élevé d'utilisateurs. Une attention particulière a été portée à la qualité de l'eau afin d'assurer que celle-ci demeure constante tout au long de la chaîne d'approvisionnement, de la source jusqu'au point de consommation, des problématiques concrètes ayant été observées relativement aux pratiques de transport et d'entreposage. En complément, diverses activités artistiques et des formations ont été déployées pour sensibiliser les populations et les agents locaux de la santé à l'importance de la qualité de l'eau. Finalement, les instances de gouvernance ont profité d'un appui continu leur permettant d'assumer pleinement leur rôle dans la coordination et la gestion durable des services et infrastructures mis en place.

A woman selling products from her garden in a local market

### Conclusions et Recommendations

L'exemple du Projet Burkina Faso illustre à la fois la complexité des enjeux liés à la durabilité des services d'eau en milieu rural et le potentiel que recèle le renforcement des capacités comme solution à cet enjeu. Ainsi, les différentes actions déployées dans le cadre du Projet démontrent comment l'instauration d'une dynamique de collaboration et de dialogue entre les différents acteurs peut avoir un impact positif sur la mobilisation et l'engagement des communautés et autres parties prenantes. De plus, le Projet montre de quelle façon le renforcement de la gestion et la gouvernance locales peut se répercuter directement sur la fiabilité et la fonctionnalité des services d'eau, garantes de leur durabilité. Impliquer les populations tout au long du processus de développement et d'exécution d'un projet et déployer des efforts continus pour sensibiliser les usagers à l'importance d'adopter des comportements responsables constitue un facteur additionnel contribuant à la pérennité des services.

Adopter une approche participative ancrée dans la communauté demande certes un degré élevé de flexibilité, une connaissance profonde du contexte local et une volonté d'investir temps et ressources dans le renforcement des capacités et le transfert des connaissances. Il est toutefois permis de croire que l'impact et les bénéfices d'une telle démarche dépasseront largement ses coûts en facilitant une réelle appropriation par les communautés participantes des services d'eau offerts à la population.

L'approche intégrée de ONE DROP au Burkina Faso a déjà porté fruits ailleurs dans le monde: en Amérique latine et Caraïbes (Nicaragua, Honduras, Salvador, Haïti, Mexique, Guatemala) et en Inde (Odisha, Bihar). Sa reproductibilité a donc été démontrée, et les résultats tendent à confirmer la pertinence d'intervenir de façon simultanée et intégrée sur plusieurs fronts, pour un impact renforcé et durable.

Le développement de nouveaux projets amorcés au Mali (2015) et au Burkina Faso (2016) viendra consolider les bénéfices générés par cette première initiative en sol burkinabé en favorisant les échanges et le transfert de connaissances, permettant l'ouverture de nouvelles opportunités de développement à l'échelle régionale.

### Références

## SUSTAINABLE SERVICES

### Government, Decentralisation & Governance

- DAVIS, S. (2016) *Statistics on Water Point Failure*. Available at: <https://improveinternational.wordpress.com/handy-resources/sad-stats/>. [consulté le 25 avril 2016]
- FAO (2014). *Country Fact Sheet: Burkina Faso*. [pdf] FAO. Available at: [http://www.fao.org/nr/water/aquastat/data/cf/readPdf.html?f=BFA-CF\\_eng.pdf](http://www.fao.org/nr/water/aquastat/data/cf/readPdf.html?f=BFA-CF_eng.pdf). [consulté le 25 avril 2016]
- MINISTÈRE DE L'AGRICULTURE, DES RESSOURCES HYDRAULIQUES, DE L'ASSAINISSEMENT ET DE LA SÉCURITÉ ALIMENTAIRE (MARHASA) (2016). Rapport bilan de mise en œuvre de la réforme du système de gestion des infrastructures hydrauliques d'alimentation en eau potable en milieu rural et semi-urbain. Ouagadougou : MARHASA.
- JOINT MONITORING PROGRAM (OMS ET UNICEF) (2015). *Progress on Sanitation and Drinking Water- 2015 Update and MDG Assessment*. Genève: OMS.
- MORIARTY, P., (2013) Trends in Rural Water Supply : Towards a Service Delivery Approach. *Water Alternatives*, 6(3). [consulté le 20 avril 2016]
- PNUD (2015). *Rapport mondial sur le développement humain 2015- Le travail au service du développement humain* [en ligne]. [http://hdr.undp.org/sites/default/files/2015\\_human\\_development\\_report\\_overview\\_fr.pdf](http://hdr.undp.org/sites/default/files/2015_human_development_report_overview_fr.pdf) (consulté le 15 août 2016).

## SUSTAINABLE SERVICES

### Private Sector, Public-Private Partnerships (PPPs), Public-Private-NGO Partnerships

#### 3.3.5 Private Sector, Public-Private Partnerships (PPPs), Public-Private-NGO Partnerships

---

## FundiFix: exploring a new model for maintenance of rural water supplies

---

Type: Short Paper (up to 2,000 words)

**Authors** J. Katuva (PhD researcher, Oxford University, UK, [Jacob.katuva@spc.ox.ac.uk](mailto:Jacob.katuva@spc.ox.ac.uk), +447707248632); S. Goodall; P. Harvey; R. Hope; A. Trevett

### Abstract/Summary

A critical building block of sustainable rural water services in sub-Saharan Africa is achieving financial sustainability by blending flows of finance from users, governments and development partners. A model for maintenance service provision (the FundiFix model) is described, based on prepaid user contributions, performance-based contracts and remote monitoring, providing a professional and rapid maintenance service for community water supplies (initially serving handpumps). Results from the first year of operation show 30% sign-up and 81% collection efficiency of monthly service fees, suggesting that rural communities can and will pay regularly for reliable services which create value. Strengthening institutional coordination and scaling up the business model to include the full range of rural water supply technologies and increase service area are future steps towards financial sustainability. A Maintenance Trust Fund will coordinate financial flows from different sources and provide support to private service providers through results-based payments.

### Introduction

Sustainable rural water services, (in particular financial sustainability) have become a ‘holy grail’ for national governments and the development community in sub-Saharan Africa in recent years. Carter et al (2010) highlighted the need for financial viability and the design of new cost-sharing arrangements in relation to handpump maintenance, and the same applies to all water supply infrastructure. A variety of management models are in use around the world from community management, through varying degrees of private and government/local authority involvement; however few have been able to deliver reliable and financially sustainable water services in rural areas. While full cost recovery remains the ideal endpoint, in reality a blend of tariffs, taxes and transfers will be necessary for financing operation and maintenance of water supply infrastructure. This briefing paper presents the initial results from a model of maintenance service provision, developed in Kenya (Oxford/RFL, 2015) with insights for policy-makers, enterprise, local government and development partners. The study area is in the semi-arid north of Kitui County, covering two wards with a population of 50,766 (surface area 2,466km<sup>2</sup>) where the main livelihoods are agro-pastoral. Over half of the 512 water points are unimproved and seasonal (streams, unprotected shallow wells, earth dams) while year-round sources include kiosks linked to a major pipeline, deep boreholes and handpumps. There is strong seasonal variation in water use, with high demand for and reliance on year-round sources in the dry season (July-Sept) while in the rainy season surface water and shallow wells are preferred.

### Description of the Case Study – Approach or technology

The FundiFix model is premised on a local company improving the maintenance of rural water services financed through user payments and performance-based transfers linked to objective metrics of service delivery in a form of public-private partnership. A choice experiment carried out with water users in the study area showed that private sector and government were preferred over community management (Hope, 2015). The name ‘FundiFix’ pays homage to local and skilled mechanics (‘fundis’ in Swahili).

Key components of the model are:

## SUSTAINABLE SERVICES

### Private Sector, Public-Private Partnerships (PPPs), Public-Private-NGO Partnerships

- A local company acts as a **maintenance service provider (MSP)** as opposed to a water service provider such that they are not responsible for a legacy of poor installation or changing environmental conditions. MSPs can monitor water quality metrics as required but in cases of health risks the burden for action would be with mandated government agencies.
- **Working at scale pools risk** across multiple systems, and is a core principle underlying the model. Water security risks to individual communities and households are reduced, and a high quality maintenance service becomes viable with pooling of revenue and costs.
- Regular **prepaid user contributions** are made through M-PESA (a **mobile money** service in Kenya), and registered users (up to ten community and committee members) are sent notifications of payment and reminders via SMS (text message). This provides an efficient and transparent mechanism for financial flows from rural water users to the maintenance service provider, one element of **sustainable finance (tariffs)**.
- **Affordable tariff** - Observed handpump usage data allow variable tariffs to be designed with provision for regular, low or special cases. Most communities fall in the former; low users are monitored with a reduced tariff; and ‘special’ cases, including schools, clinics or other facilities with hand-pumps benefit from a reduced rate. The latter provide a basis for government support through ‘taxes’.
- **Transfers** (the third element of sustainable finance) are also necessary to sustain water services to the rural poor and can feed into the model through performance-based payments from a coordinated financing mechanism (currently being set up as a Water Services Maintenance Trust Fund).
- Providing a professional service is linked to **performance-based contracts**. The service provider is responsible for providing repairs within an agreed timeframe. For example, if a handpump repair takes longer than three days, communities receive a free month of service, so building in penalties for poor performance.
- **Remote automated monitoring** occurs through transmitters fitted to pump handles that monitor movement (usage and functionality) and send data to a central server using the mobile phone network. The status of handpumps in the system can be remotely monitored via a web-based interface. This is essential for validation of repairs and information sharing in remote rural areas, keeping the service accountable to government (in this case County Governments and national regulator), donors and other stakeholders. A range of performance metrics are reported in the ‘Rights to Results’ report (Oxford/RFL, 2014), including unit cost of water produced, percentage downtime, operational efficiency etc.
- **Unit of analysis**. As each handpump is managed differently related to group size, water demand, access rules, alternative water sources and other factors, the decision was made to collect a ‘community payment’ per handpump rather than individual payments to reduce the complexity and transaction costs of cost recovery at scale.

The model has been trialled in Kenya with two private limited companies registered and operational (in Kitui County since January 2015, and Kwale County since January 2016), in collaboration with County Ministries responsible for water services. A free trial of the maintenance service built trust with potential customers before a contract was signed. A rapid maintenance service is offered to handpump users, for a fixed monthly tariff that is paid using mobile money services. A small office provides a physical presence and focal point for enquiries, and stores high quality spare parts. When a handpump breaks down, any user can call a hotline number to notify the company. A FundiFix mechanic, equipped with a motorbike and tools, responds as soon as possible to diagnose the problem and carry out the repair. Data collected during 2015 are analysed and presented here, including payment behaviour, operational performance, and enrolment/non-enrolment.

### Main results and lessons learnt

#### Community enrolment

The likelihood of community enrolment was evaluated prior to implementing the model through focus group discussions. The majority of groups (89%) stated they would commit to a pre-payment maintenance service after the pilot, with willingness to pay at an average level of USD 250 per year per

## SUSTAINABLE SERVICES

### Private Sector, Public-Private Partnerships (PPPs), Public-Private-NGO Partnerships

handpump, a 2.5-fold increase on pre-service payment levels (Oxford/RFL, 2014). Figure 1 shows the actual sign-up figures falling below pre-implementation optimism with just under one in three (30%) of the 66 communities registering.

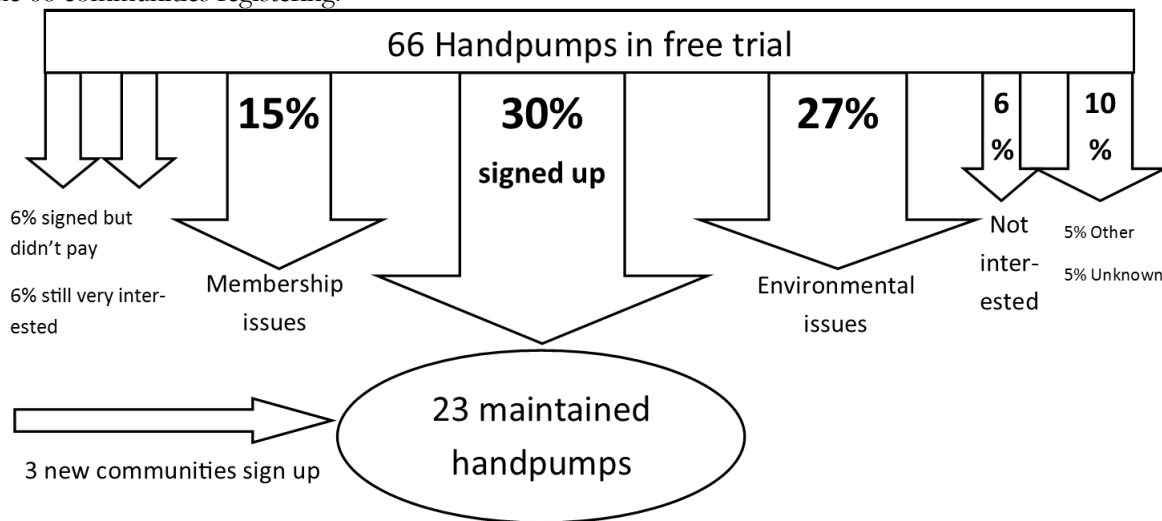

**Figure 56 Evaluation of community enrolment for maintenance service (Feb-Dec 2015)**

Environmental issues were the principal reason for non-enrolment (27%) with a quarter of these reporting high salinity, and three-quarters with low water levels and well-collapse, caused by poor construction and siting as (handpumps are often fitted to hand-dug shallow wells by seasonal riverbeds). Here, handpump maintenance is not the main concern, rather the water resource itself. Membership issues were the second major reason (15% of total) for non-enrolment. Interviews identified poor organisation, lack of agreement between members and leaders, or waiting for committee elections as constraints to enrolment.

This lower than predicted sign-up highlights the legacy of clustered and poor quality infrastructure with a lower proportion of handpumps that are “clustered” signing up than single or paired handpumps. It also has significance for model implementation, demonstrating that user tariffs from handpumps alone, and in a limited geographic area, will not sustain a viable business model. However, when combined with flows from taxes and transfers, the business case still makes economic sense as these additional inputs can be compared to the losses and wasted investment of infrastructure failing before the end of its design life due to a lack of maintenance.

### Operational performance

In 2015, FundiFix made 98 repairs to 25 handpumps (per handpump, range: 0-25; mean = 3.9; median = 2). Five handpumps received no repairs, and in general groups with fewer repairs were more likely to be in arrears on their monthly payments, not being familiar with insurance models and feeling that they should not be paying for a service if they are not visibly benefitting. Implementing regular preventive maintenance visits addressed this to some extent, and cases where customers in arrears required a repair were handled on an individual basis. All but two repairs were made within three days, 40% on the same day as notification, 41% the following day and 16% on the second day, with an average repair time of 0.9 days, down from 27 days previously. Delays were caused by insecurity (livestock and human conflict) and waiting for water level to subside before the community could desilt a well, and were not outside of contractual obligations.

Performance is skewed by nearly half of the repairs (45%) attending to three handpumps: one had not been part of the free trial, is deep and heavily-used and required replacement of several parts, and another had a rusted cylinder, which was causing rapid wearing-out of the U-seals. Pooling risk at scale underlies the economic logic of the FundiFix model and most insurance schemes. The flip-side is that a fifth of handpumps (20%) did not require any repairs during the time period, thus evening out costs. All repairs were carried out by one fundi (pump mechanic), using a motorbike provided by the Sub-County water office.

## SUSTAINABLE SERVICES

Private Sector, Public-Private Partnerships (PPPs), Public-Private-NGO Partnerships

### Financial performance

Affordable tariffs were set based on previous payment behaviour, willingness to pay surveys and volume usage data. This translates to USD<sup>1</sup> 0.38 per household per month (range USD 0.02-1.67), with an average of 55 member households per handpump for those that signed-up, compared to an actual payment average of USD 0.2 per household before the trial and a willingness to pay of USD 1 per household for the service (Oxford/RFL 2014). The monthly willingness to pay per handpump was USD 21 (a 2.5-fold increase on pre-service levels) so a monthly tariff of USD 10 was considered a reasonable compromise and an attractive and affordable rate. Setting volumetric tariff levels was made possible because of the initial free trial period, during which transmitters monitored volumetric usage.

Tariff level	Monthly payment amount (USD)	Number of handpumps signed-up
Normal (>15m <sup>3</sup> /month)	10	12
Low (3-15m <sup>3</sup> /month)	5	7
Special (<3m <sup>3</sup> /month)	1	4

Income in the first year (2015) was USD 1,538 with 79 per cent in monthly payments, and 21 per cent in registration fees. This represents 81 per cent collection efficiency overall. There was a downward trend in collection efficiency, which merits further research. Some non-payments are due to personal circumstances; others are related to the distance to access a mobile money agent or seasonal changes in handpump usage. Overdue payments are followed up using the FrontlineSMS software, allowing a number of community members to be reminded by SMS, as well as personal phone calls or visits where possible.

Expenditure over the first year of operation, including local costs of running the maintenance service (transport, labour, spare parts and information), office rental, utilities, support staff and consumables was around USD 7,700. With 6,000 people using the maintained handpumps, maintenance costs per capita were USD 1.28 per year. This translates to 20% of operating costs being covered by user payments, with 80% covered by transfers from research grants during the pilot phase, while in future the shortfall will be met by results-based payments from a Water Services Maintenance Trust Fund, coordinating taxes and transfers. A simple financial model projects that maintaining a portfolio of 100 handpumps with the same collection efficiency and tariff distribution, would increase cost coverage to 33%. Adding different technologies such as piped schemes, increasing the service area and service levels with higher tariffs would cover higher proportions of fixed costs, thereby paving the way to a sustainable business model.

<sup>1</sup>An exchange rate of 1 USD = 100 KES is used throughout.

### Conclusions and Recommendations

Initial results from the FundiFix pilot have been promising, showing significant reductions in downtime and good payment rates linked to performance. Where environmental issues and legacy effects such as clustering of infrastructure are taken into account, rural handpump users can and will pre-pay for a quality maintenance service, which can be facilitated by mobile money services. The experience has highlighted various surmountable challenges such as using mobile money services in rural areas (access to agents and network, familiarity), the complexity of community management and the challenge of group decision-making (community coherence), and seasonality of income in rural areas. In addition, where water sources are unreliable (eg. seasonal), undesirable (eg. salty) or of poor construction quality users are unlikely to pay for maintenance, underlining the need for greater attention to assuring the quality of new developments. Allowing a model with private sector involvement in operation and maintenance enables governments and water departments to focus on developing quality new infrastructure, but requires detailed work on risk-sharing and contractual responsibilities between the management committee, the maintenance service provider, Government and regulator which is ongoing.

## SUSTAINABLE SERVICES

### Private Sector, Public-Private Partnerships (PPPs), Public-Private-NGO Partnerships

FundiFix's goal is to expand both geographically and by type of infrastructure maintained, and to continue to develop a sustainable business model. This is necessary to improve financial sustainability by spreading the fixed costs of the business across a wider portfolio of rural water supply infrastructure such as piped water schemes for communities, schools and clinics. Experience of the model demonstrates that rural water supplies can be repaired within performance benchmarks that satisfy users. It has the potential to be financially sustainable through operation at scale, and commitment and recognition of the need for tariffs, taxes and transfers to facilitate the human right to water.

Interest from county government and private sector partners is leading into the next phase of work, supported by UNICEF, of establishing a Water Services Maintenance Trust Fund blending user, government and donor finance. The Fund provides a results-based framework to both expand and replicate the model to deliver universal drinking water security, and the potential to act as a mechanism to hold MSPs accountable to key performance indicators of service through results-based payments, alongside service users.

### References

- Carter, R.C., Harvey, E. and Casey, V. (2010) IRC Symposium 2010. WaterAid, UK
- Hope, R. (2015) Is community management the community's choice? Implications for water and development policy in Africa, *Water Policy*, 17, 664-678
- Oxford/RFL (2014) From rights to results in rural water services – Evidence from Kyuso, Kenya. Working paper 1. Smith School of Enterprise and the Environment, Oxford University, UK.
- Oxford/RFL (2015) Financial sustainability for universal rural water services – Evidence from Kyuso, Kenya. Working paper 2. Smith School of Enterprise and the Environment, Oxford University, UK.

## SUSTAINABLE SERVICES

Private Sector, Public-Private Partnerships (PPPs), Public-Private-NGO Partnerships

---

# Public Private Partnership for Rural Water Supply: Experiences from Zimbabwe

---

Type: Long Paper

**Authors:** *Tameez Ahmad (WASH Manager, UNICEF Zimbabwe Country Office, Email: [tabmad@unicef.org](mailto:tabmad@unicef.org), Zimbabwe, Tel: +263 4 703941/2 ext 2483), Victor Kinyanjui, Maxwell Jonga, and Hasios Ronald Mashingaidze*

### Abstract/Summary

The Rural WASH Project was implemented in rural areas of Zimbabwe covering 33 of 60 rural districts aiming at improving access to WASH services for the most vulnerable and disadvantaged people. Under this project Private Public Partnership (PPP) models were tested leading to repair and rehabilitation of 10,361 of water points mainly hand pump equipped boreholes, and development of WASH PPP National Strategic Framework, a key policy and strategic framework to shape the future of PPP for Operation and Maintenance of rural water supply. The process also included a huge capacity building of the 33 districts, 5 provinces and national structures on various aspects of WASH; and community based structures on operation and management of water points. Overall the Rural WASH Project has achieved a great success with reaching over 3 million people with access to improved sources of drinking water mainly through repair and rehabilitation of non-functional water points.

### Introduction

#### Background

In the mid-1990s, Zimbabwe had attained a very high level of service delivery with respect to both rural and urban water supply. Water resources development also kept pace with demands across key sectors; irrigation, industry and mining among others. However, the economic downturn of 2000-2009 created not only a capacity gap to manage the aging infrastructure but also limited further WASH sector expansions. The collapse of water revenues that started in the late 1990s and continued during the last decade led to a decline in water supply services from 79% in 1990 to 77% in 2015. The collapse affected all parts of the country and all aspects of water supply, water resources management and development. This had a significant impact on the quality and reliability of services. The 2008-2009 cholera outbreaks which resulted in 98,592 cases and 4,282 deaths was the manifestation of deteriorated WASH services (UNOCHA, 2009).

In response to the cholera outbreak, the donor community invested in the sector for rehabilitation and provision of WASH services while the government with support from the development partners undertook major initiatives including development of National Water Policy (2012), strengthening coordination mechanisms, and piloting a WASH Information Management System.

In June 2012, Government of Zimbabwe, with support from UNICEF, initiated a four-year (June 2012 to June 2016) Rural WASH Project covering thirty-three (33) of the sixty (60) rural districts from five (5) provinces of Zimbabwe. Project districts and provinces were selected based on vulnerability criteria which included existing level of access to WASH services, prevalence of WASH related disease (e.g., cholera cases reported during the outbreak), and presence of any other ongoing WASH interventions (Government of Zimbabwe and UNICEF, 2012). The project had a total funding of USD 62 million provided by the UK Government (about USD 52 million), Swiss Agency for Development Cooperation (about USD 6 million) and UNICEF (USD 4 million).

### RWP Thematic Areas and Major Activities



## SUSTAINABLE SERVICES

### Private Sector, Public-Private Partnerships (PPPs), Public-Private-NGO Partnerships

Under the project, WASH interventions were implemented in the following four (4) RWP thematic areas through government structures with support from ten (10) Civil Society Organizations (INGO/NGOs) referred to as Implementing Partners (Ahmad et al, 2016a).

- a. Rehabilitation and construction of new WASH infrastructure.
- b. Demand-led sanitation and hygiene promotion.
- c. Public- Private Partnership (PPP) for operation and maintenance (O&M) of water supplies.
- d. WASH Sector Governance.

The third component, which is the focus of this paper concentrated on building sustainable community based O&M systems for water supplies (hand pump equipped boreholes, deep and shallow wells and piped schemes) through private sector partnerships/participation.

This paper aims at sharing experiences gained from the Rural WASH Project implementation with special focus on improving the Drinking Water Supply, Operation and Maintenance Systems through promotion and community capacity building in Public Private Partnership approaches and models in community based WASH service provision, operation and maintenance systems. Improved WASH services provision, O&M system also aimed at increased sector potential to attain the water supply Millennium Development Goals (MDGs) and Sustainable Development Goals (SDG) of improved access to and use of safe drinking water by the most vulnerable and disadvantaged people in rural areas.

### RWP Implementing Partners

Government of Zimbabwe and UNICEF Zimbabwe were responsible for overall Rural WASH Project management including managing project funds and provision of technical support. Project field activities were implemented through the ten (10) Civil Society Organisations selected through Government of Zimbabwe led transparent competitive processes from the initial thirty-two (32) CSOs who had expressed interest.

### Moving away from Government managed systems to community based management system

As presented above, traditionally, O&M of water facilities/systems had been the responsibility of the Central Government since independence. However, due to economic downturn especially during the 2000 – 2009 period, the government was unable to provide required support for the declining WASH coverage rates and service provision standards which were exacerbated by aging systems and had resulted in the 2009/2010 cholera outbreak. As reflected in the national water policy, services decline was triggered by the collapse of the economy.

Traditionally, community dependence on external assistance and inadequate mechanisms for sustainability perpetuated the vulnerability of water supply services, created a dependence syndrome and loss of sense of community ownership of communal water supplies. Rural WASH development had stagnated since 1990. Maintenance and repairs virtually ceased as government failed to provide financing for these activities including supply of operation and maintenance spares leading to inactivity/total collapse of the three-tier operation and maintenance system – the motorised district maintenance teams, ward pump minders and volunteer pump caretakers could not be retained (Government of Zimbabwe, 2012).

At the height of the challenges, reports were that at any given time approximately 40% of the estimated 47,000 hand pumps were non-factional due to the collapse of the three-tier O&M system. The need for a review and adoption of other sustainable O&M options was inevitable.

The Zimbabwe WASH sector witnessed a paradigm shift with the Cabinet approval of new Water Policy (2012) which stated that public and development partner finance for rural WASH would focus on capital development and behaviour change whilst user finance would cover O&M costs. Prior to approval of the 2012 Water Policy, the WASH sector had sought and secured Government support and approval of the Community Based Management (CBM) policy guide.

## SUSTAINABLE SERVICES

### Private Sector, Public-Private Partnerships (PPPs), Public-Private-NGO Partnerships

The CBM Guide emphasised the need for decentralised management of WASH service provision particularly the O&M of water supplies with community of users through the WASH coordination and management structures (Village Development Committees, Water Point Committees etc.) required to assume the water points O&M responsibilities.

The Water Policy and CBM provisions were further reinforced with the provisions of the current Zimbabwe Agenda for Sustainable Socio-Economic Transformation (ZimASSET) – an economic recovery blueprint – which states that PPP approaches are an integral component of the sustainable economic recovery process and one of its broader key assumptions is the “increased investment in infrastructure such as... water and sanitation through accelerated implementation of the PPPs and other private sector driven initiatives.” In fact two of the ZimAsset key strategies for achieving the improved water supply outcome include “to mobilize local communities into water point management committees and engage private sector to maintain borehole equipment” (Government of Zimbabwe, 2013).

### Why Public-Private Partnership Approaches

Adoption, prioritisation and implementation of the WASH Sector PPP Approaches and Models was a move to address a complex set of water supplies O&M system *operational* challenges including the following major ones, chief among them being:

- a. Lack of a sustainable O&M strategy to address the unacceptably high hand pump breakdown rates as over forty percent (40%) of the more than 47,000 hand pumps were reported not functional at any given time. This translated to long water points’ down-times that could be more than a month and in extreme cases running to over a year.
- b. RDCs’ institutional weakness to comprehensively handle the O&M inputs supply chain.
- c. Weak WASH inputs supply chains due to a myriad of supply chain challenges.
- d. Weak community self-reliance systems in O&M of water points partly due the historical and inherent weaknesses of the three-tier O&M system.
- e. The increased demand for O&M costs investments as a result of the expanded adoption of traditionally rural water supply technologies (hand pumps) in urban settings - emerging and growing peri-urban areas.

At higher strategic levels, the Rural WASH Sub-Sector PPP objectives were to:

- a. Leverage private sector capital to fund rural WASH infrastructure O&M costs and address reduced sustainability of central government & local authorities financing.
- b. Unlocking a range of private sector skills.
- c. Leverage PPPs business planning practice that are depended on feasibility and strategic responsibility alignment.
- d. Applying the “*allocate risks to the party best able to manage them*” PPP principle on the assumption that community based private partners have the right skills to manage, operate and maintain water supplies on a more sustainable basis.
- e. Delivery of budgetary certainty as PPP approaches, principles and agreements address the need for clarity on the O&M funding sources – the users’ community.
- f. Apply the PPP principle of linking payment to quality of services provided. Where quality services are not delivered the private service provider is liable to pay penalties.
- g. Promote sustained community based demand and ability to pay for O&M stimulates WASH market growth - WASH inputs and commodities and inputs stocking by local retailers.

### Who are the Public and Private Partners/Players at What Level

The Figure below demonstrates the Public and Private Partners for the water point O&M as spelt out in the 2015 Zimbabwe Rural WASH Sub-Sector Public Private Partnership (PPP) Framework document. This figure shows Public and Private Partners at national, sub-national, and community/local levels.

## SUSTAINABLE SERVICES

Private Sector, Public-Private Partnerships (PPPs), Public-Private-NGO Partnerships

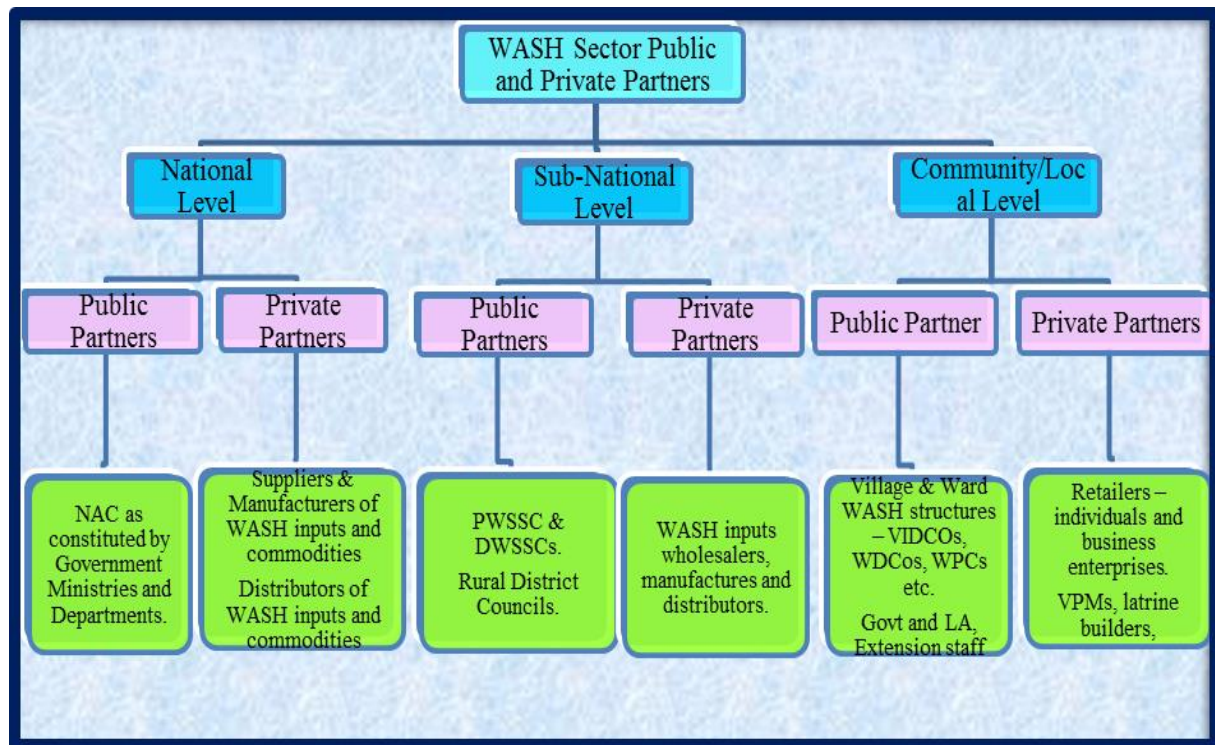

### PPP Focused Water Point O&M Systems and the Key Players

The PPP focused water supplies O&M system is district based – its structures are from the water point level up to the district level with the following key players whose roles, responsibilities and conditions of operation are explained below. Its key performance indicators is enhancing timely availability of affordable spares and water point maintenance services from locally accountable service providers.

### Pump Caretaker

This is a Water Point Committee (WPC) member responsible for day to day routine preventive maintenance works of the respective water point. The cadre reports to the WPC that has the overall mandate of defining the O&M course of action e.g. the need for resources mobilisation from the community, engagement of the Village Pump Mechanic (VPM) etc.

### The Water Point Committee

This is a community elected Water Point Committee (WPC) responsible for coordinating water point day-to-day management, operation and maintenance activities. Some of its key activities include ensuring water point users adherence to the provisions of the water point committee constitution, timely response to breakdowns, O&M resource mobilisation and accounting etc.

While WPC terms of reference may last longer, members' term of office depends on community satisfactions with the WPC performance. Non-performing members or committees may be voted out following the provisions of the respective water point constitutions. WPC do not have legal ownership of water points but have usufruct rights. The respective Rural District Councils are the custodians of all communal water sources in their respective areas of jurisdiction. It should be noted that under the Rural WASH Project 10,338 WPCs have established and strengthened in the 33 districts through a massive capacity building exercise.

Efficient operation of WPC indirectly entails creation and development of a sustainable WASH input and spares market especially for the local retailers.

## **SUSTAINABLE SERVICES**

### **Private Sector, Public-Private Partnerships (PPPs), Public-Private-NGO Partnerships**

#### **The Village Pump Mechanic**

This is a community based, selected, trained and tool box equipped cadre responsible for water point O&M on a payment basis. Unlike the former pump minders under the three-tier system, Village Pump Mechanics (VPMs) do not receive an agreed fixed stipend or allowance neither from central or local government nor the WPC but are paid an agreed service fees by the water point users for the respective services provided. The service fee may be dependent on a number of factors such as the amount of work, time taken, source of the required spares, community inputs during the performance of the maintenances works etc. In short, this is a mutually agreed business transaction that should attend to the transaction needs of the two parties i.e. quality service for the consumer and fair remuneration on the part of the VPM.

It is important to note that unlike the pump minders or caretakers who had responsibility over water points in given geographical area i.e. village or ward, the communities through the Water Point Committees are free to hire VPMs from different villages or wards depending on ones’ service delivery competitiveness such as affordability of charges and service quality. VPMs are therefore in a way freelance technicians who have to provide competitive services for them to realise meaningful returns from their work and enjoy a larger market share of the water points. It is practical that as part of the service competitiveness, VPMs can source and provide their own spares to enhance their competitiveness. It is therefore one of their strategic market objective to develop a sustainable WASH market.

Currently, the average VPM distributions is three per ward with an average of 50 water points per ward. This translates to a VPM water point ratio of about 1 to 17. During the implementation of the RWP, 2,560 VPMs were trained through two-week comprehensive field based practical training, and over 500 VPM tool kits were provided to the districts to be accessed by these trained VPMs. The VPM tool kits are placed at a central locations (e.g., school, with relevant government body at ward level) to be accessed by VPMs for repair and maintenance. Currently, discussion has been initiated to chalk out a strategy for cost recovery to the centrally managed systems for VPM tool kits particularly for replacement of damaged/lost items/VPM tool kit without any external support from donors or government. This may lead to fixing a minimal fee on use of this kits by VPMs to recover the capital cost, and also VPM buying their own VPM kits with the passage of time as the market condition improves.

#### **WASH Spares Retailers**

These are local outlets from whom WPCs or the VPM can source spares for maintenance of water points. Through the RWP, efforts were made to mobilise and provide business training on WASH inputs marketing, and promotion of business linkages between the local retailers and wholesalers. A number of RWP implementing partners also entered into Memorandum of Understandings (MOUs) with local retailers. The MOUs covered mutual strategies and support mechanisms that would enable the retailers to acknowledge the business potential and develop interest in marketing WASH inputs in general and the water point maintenance spares in particular.

#### **WASH Inputs Manufacturers**

These usually operate at higher levels based in major urban areas. However, through project interventions, effort were carried out to strengthen their business operation and development of the spare parts distribution network. A national bush pump manufacturers’ capacity assessment was conducted to assess their production systems challenges, product quality, distribution systems etc. Provision of quality spares enables consumers to get value for money as quality spares reduce water point downtimes. A pre-delivery inspection mechanism of water supplies inputs by government have also been developed to ensure distribution of quality wash materials and spares.

#### **Central Government and the Local Authorities (Rural District Council)**

## **SUSTAINABLE SERVICES**

### **Private Sector, Public-Private Partnerships (PPPs), Public-Private-NGO Partnerships**

As highlighted above, the Rural District Councils (RDCs) are the custodians of all water points in their respective areas of jurisdictions. RDCs also have the responsibility of carrying out major rehabilitation/repair works and provision of new drinking water supplies. However, due to capacity challenges, major rehabilitation of water points are carried out by the District Development Fund’s District maintenance team. It is imperative to note that the District Maintenance Teams have their own challenges e.g. due to resource constraints most of them use tractors to cover the width and breath of districts. Construction of new water sources has also been widely outsourced from private drillers. Private drillers are supervised by trained Government and RDC drilling supervisors.

Under the RWP, implementation and monitoring capacity of RDCs in the 33 districts, five provinces, and national government has been significantly enhanced and strengthened through various trainings including monitoring and supervision of borehole drilling, financial management, information management, water quality, pre and post-delivery inspection of supplies, demand led sanitation and hygiene promotion and through provision of 48 vehicles, 165 motor cycles, IT related equipment amongst others. In addition coordination mechanisms at district level (District Water Supply and Sanitation Sub-Committees-DWSSCs), provincial level (Provincial Water Supply and Sanitation Sub-Committee-PWSSCs) and national level (National Coordination Unit-NCU) were established/strengthened. These structures being fully functional played a critical role in the success of RWP in achieving the planned results.

#### **The Public-Private Partnership Models**

As part of the implementation of RWP, various PPP approaches and models were tested and experimented for O&M and provision of water point O&M spares covering the following PPP roll out stages that led to improved water point maintenance, reduction of repair cost, and availability of WASH supplies and services close to the communities.

#### **Stakeholder Mobilisation and Conscientisation**

The initial activity in PPP roll out was stakeholder mobilisation and conscientisation that involved implementation of the following actions:

- Community and stakeholder awareness and sensitisation meetings and workshops on the water point O&M system challenges and the Community Based Management (CBM) concept potential to address the challenges.
- Stakeholder awareness on the strategic roles of the private sector in water point O&M, emphasising the need for paradigm shift from centralised to decentralised systems that encourage private sector participation e.g. the VPMs and local retailers.
- Local retailers’ sensitisation on the business potentials and opportunities in WASH sector in general and the water point O&M systems in particular. These included establishing business linkages amongst WASH supplies wholesalers, local dealers/outlets, government, private WASH service providers for O&M (e.g., VPMs), and communities as ultimate consumers of WASH services. To formalise the business linkages mechanisms, Memoranda of Understanding (MOU) were entered into between the various Public-Private Partners. Most common MOUs were between the Civil Society Organization (CSO) organisations and the WASH inputs wholesalers and local retailers. Other existing business alliances/fora such as the Agro-Dealers Association were taken advantage of. In districts where local retailers were organised into Agro-Dealers Associations, business linkages including the MOUs were also entered into at that level. Households and communities through their representative WASH coordination and management institutions i.e. WPCs, also entered into service MOUs with local services providers - VPMs. These arrangements included determination and enforcement of agreed service fees and other contractual provisions.

## **SUSTAINABLE SERVICES**

### **Private Sector, Public-Private Partnerships (PPPs), Public-Private-NGO Partnerships**

- Marketing of the WASH sector PPP approaches through existing business linkages/associations or alliance such as the Agro-Dealers Associations.
- Reorientation of Government structures and officials at all levels of operation.
- Co-option of business representatives in Provincial, District and community level WASH coordination and management structures to ensure transparency and business confidence in market potential in water points O&M.

### **Demand Creation/WASH Inputs Market Development Strategies**

A matrix of reinforcing actions were implemented to generate or develop the local market for water point O&M inputs. These included:

- Formation of District PPP task forces of the DWSSC with a specific lead institution to spearhead the PPP component. In all Districts, the ministry responsible for Small and Medium Enterprises and Cooperative Development was appointed to lead.
- Revitalisation of existing and establishment of new WPC to spearhead O&M activities at water point level.
- Appointment, training and equipping of private VPMs who operate as freelance technicians and market themselves through provision of competitive water point O&M services.
- Community mobilisation and hygiene education through the demand led sanitation and hygiene approaches that emphasised adoption of positive hygiene behaviours and practices inclusive of safe use of clean water to trigger community willingness to invest in water point O&M costs for continued availability of safe drinking water.

### **Resource Mobilisation and Funding Procurement of O&M inputs.**

Community based structures mobilized household and community resources including financial resources required for procurement of WASH inputs and materials through the establishment of Water Point Funds. Evidence from field indicate that majority of the WPCs maintain Water Point Fund balances ranging from US\$30.00 to a US\$100.00 at any given time(National Action Committee,2015a). These amounts are at least adequate to finance a single water point repairs task allowing the WPC to mobilise for the next breakdown.

Some of the project implementing partners negotiated supply of O&M inputs to local retailers by wholesalers on consignment basis. This was in attempts to address one of the major challenges in the WASH input supply chain under the PPP approaches i.e. absence of appropriate financial markets that could enable WASH input supply chain actors (manufacturer, distributors, wholesalers, stockists, retailers, consumers etc.) to actively participate in the market. Besides the Water Point Funds and the few examples where local retailers accessed O&M inputs on a consignment basis from the wholesalers, there are no other major funding streams for water points repairs spares.

### **Market Size Estimation and Reporting - Mapping of WASH Services under Rural WASH Information Management System (RWIMS)**

Establishment of the Rural WASH Information Management System (RWIMS), a sector information management system is ongoing. It was established in 36 districts under the RWP while plans have been agreed to cover all the remaining districts in the country in the next 2 years. RWIMS is an automated system where designated focal persons at district (based at the RDC) and ward level, usually government extension workers, collect comprehensive information on mapping of WASH services through Village Based Consultative Inventory (VBCI) using smart phones. Through the smart phone, captured data is automatically fed to the national system via internet. The system allows generation of online reports on different aspects of WASH including GPS based mapping of non-functional water points.

## **SUSTAINABLE SERVICES**

### **Private Sector, Public-Private Partnerships (PPPs), Public-Private-NGO Partnerships**

Apart from other envisaged uses, RWMIS is expected to provide the required information especially on non-functional water points across the country creating potential and reliable source of O&M market information for private sectors planning under the current PPP framework. However, the RWIMS does not provide a platform to provide information on what action could have been taken to address the broken down water points.

Based on the PPP Framework (National Action Committee, 2015b), and lessons from field implementation, the government is also in the process of refining the PPP models for O&M by introducing an SMS based triggering system to report and facilitate rapid remedial action on repair of broken down water points. The designated focal person of the WPMC would send an SMS on breakdown of water points to a given number which will be captured through RWIMS and accordingly an automatic message with location of water point would be relayed to the nearby registered VPM and other focal government person at the district level (RDC). The registered VPMs, who have formal links with the supply outlets (local dealers of spare parts) through the respective WPMCs will repair the water points on agreed fees. The information management system will be updated on the functionality status of the water points. In cases where the reported water point is not updated the system will automatically send reminder messages to the relevant focal persons.

### **Building Capacity of Community Based Structures for O&M**

Under the Rural WASH Project, as provided in the Water Policy, a major thrust was given to capacitating community based structures for community mobilisation in WASH services repair, rehabilitation and construction of new facilities as well as operation and maintenance of water points/facilities.

Through a massive exercise in the 4 years of project implementation, over 10,338 WPCs (comprising of over 68,500 members with 62% women representation) were established and strengthened. In addition, over 2,560 Village Pump Mechanics (VPMs) were capacitated through a 14-days comprehensive training on hand pump repair and maintenance and equipped with VPM tools to carry out repair and maintenance works. Over the years these VPMs were engaged by the WPCs to repair and rehabilitate over 10,361 water points. VPMs offered their services on a mutually agreed fee per water point or services provided.

### **Improving the Enabling Regulatory Framework**

Besides the provision of an enabling environment provided in the Water Policy and the ZimASSET economic blueprint respectively, Rural District Councils have passed resolutions making it mandatory for communities to pay for spare parts and other related costs required for water point operation and maintenance. This is done to discourage communities’ reliance and dependency on government for routine operation and maintenance of WASH services and to create an enabling environment to support PPP.

In some instances, MOUs have been reached between the RDCs and private sectors (e.g., wholesalers) for the supply of the WASH materials for local retailers at ward and community levels. However, these MOUs have many weaknesses including not covering all supply chain service actors down to community based retailers and the end-users such as water point management committees. Furthermore the MOUs are not secured or guaranteed. Community based WASH constitutions at village and water point levels were also developed and approved by the local Government structures such as the Village Heads, Headman and Chiefs.

### **Main Results**

Through implementation of the RWP, Zimbabwe moved away from heavily subsidized repair and maintenance system, which had failed, to community based O&M system. This was done through formulating revised policies, strategies, and creating enabling environment. The revised approach was adopted at district, sub-district and community level through continuous advocacy, awareness raising, and capacity building activities. In terms of statistical achievements, the RWP supported formation, training

## **SUSTAINABLE SERVICES**

### **Private Sector, Public-Private Partnerships (PPPs), Public-Private-NGO Partnerships**

and equipping of cumulatively, 10,338 WPCs, and 2,560 VPMs at local level in 33 districts. As a first step, various models for PPP were tested at local levels to improve O&M of water points. These public and private WASH service providers demonstrated the strengths and possibilities associated with PPP approaches at local and community levels i.e. fulfilment of the private sector profit motive and client quality service provision expectations. This resulted in repair and maintenance of over 10,361 water points (mainly hand pump equipped boreholes) across the 33 districts (Ahmad et al, 2016a, 2016b). Some of the other tangible results are presented in below sub-sections:

#### **Development of National WASH PPP Framework**

The national government with support from UNICEF carried out documentation of the initial learnings from PPP models/approaches experimented in different districts to provide strong footings for development of National WASH PPP Framework through:

- Documenting district based PPP experiences and best practices.
- Refining, improving and consolidating the various PPP approaches and models.

Through a wide consultative process, the PPP Framework for Rural WASH was developed in December 2015. Currently, this is being reviewed for formal endorsement by the government as a national PPP policy framework. The PPP Framework intends to assist the Rural WASH Sub-Sector in launching, marketing, implementing, monitoring and evaluation of Rural WASH Sub-Sector PPP approaches.

#### **Reduction in O&M Fees**

Preliminary evidence from some of the RWP districts indicated that, training, equipping and deployment of VPMs resulted in reduction of borehole repairs costs down to as low as US\$20 from a high of US\$100 per repair. It is anticipated that achievement of targeted ten VPMs per wards would reduce the average service fees per breakdown as VPM competition increases.

Field based feedback indicate that most WPC operate Water Point Funds with majority of them maintaining a reserve balance ranging from US\$30.00 to a US\$100.00 at any given time. These amounts are at least adequate to finance a single water point repairs task.

#### **Reduction in Water Point Downtime**

Field investigation from selected areas of 8 districts indicated that the average water point downtime had reduced by at least 67%. In many instances it reduced to single digit days compared to prior months if not years. However, there is need to carry out a comprehensive field survey to assess this further in all 33 districts.

#### **Increased Product and Market Knowledge**

Increased product and WASH knowledge resulting in WASH input suppliers and retailers acting as quasi-WASH promotion agencies and increased commitment to WASH sector objectives.

#### **Challenges**

Like any initiatives, a couple of structural and operational challenges including the following were experienced in introduction and piloting of the PPP approaches and models in water point O&M:

- Most water points had been recently rehabilitated under the RWP thereby distorting the potential water point O&M market size.
- MoUs entered into between the different stakeholders were not legally binding. In most cases they were more of gentleman’s agreements based on mutual understanding. They were also not secured or guaranteed against any risks. They were not within the protection from overall policy and legal frameworks such as the RDC Act or the Water Policy.



## SUSTAINABLE SERVICES

### Private Sector, Public-Private Partnerships (PPPs), Public-Private-NGO Partnerships

- Lack of ready market especially for local water point O&M retailers to offload proceeds from of spares sold in kind.
- Water point O&M spares are generally “slow moving commodities” especially if they are manufactured to standard, correctly fitted and the water point properly operated.
- There is no comprehensive, reliable and regularly updated water point spares market information. It is expected that the ongoing VBCI and RWIMS initiatives will address this information gap.
- Continued supply of free WASH related inputs, commodities and services to communities e.g. some NGOs are still providing free inputs and DDF offer free spares and boreholes repairs once it receives government funding under the Rural Capital Development Fund.
- The infrequent borehole breakdown and low VPM-Water Point ratio means trained VPMs do not realise meaningful rewards from borehole maintenance fees that can act as sustainable livelihoods.
- There is no financial support being extended to the local wholesalers and retailers which means that their operations are constrained and this in turn affects borehole spares stocking.
- There is no financial support to local retailers who have to buy the WASH inputs using their own resources that is usually from personal savings or remittances.
- 

### Lessons Learnt

- One of the major lessons that was learned during the implementation of the project was the fact that communities are willing to embrace new approaches and make significant contributions once they are convinced of long term benefit of proposed interventions no matter how poor they could be. This was demonstrated with significant contribution by the communities for WASH services especially for small scaled piped water systems, O&M of water points.
- Another major lesson learned was that there are no quick fixes for introduction of WASH sector PPP approaches. Due processes must be followed especially for interventions requiring attitudinal and behavioural changes.
- Transparent and effective rigorous monitoring systems involving systematic sharing of progress on monthly basis with all stakeholders increase accountability and performance.
- In addition, implementation of the project through government structures created an enabling environment with increased capacity which will be a key factor for sustainability of the WASH PPP replication beyond the RWP life.

### Conclusions

Overall implementation of the Rural WASH Project in Zimbabwe is a great success with improving access to improved sources of drinking water to over 3 million people mainly through repair and rehabilitation of non-functional water points. This was done systematically by moving away from government led subsidized system for O&M to the community based system with a strong focus on PPP. Various PPP models that were tested demonstrated success of the new approach. However, Zimbabwe has to further improve and build on existing initiatives to cover the whole country and put in place a sustainable mechanism for PPP. One of strategic areas is to incorporate SMS based triggering and support mechanism into the Rural WASH Information Management System by linking communities to VPM, and VPM to private sectors for improved services.

### References

- AHMAD, Tameez et al. (2016a). Rolling out Zimbabwean approach to demand-led sanitation in most vulnerable communities. 39th WEDC Conference, Kumasi, Ghana, 2016
- AHMAD, Tameez et al. (2016b) Rural WASH Project in Zimbabwe: Monitoring and feedback mechanism for accelerating progress. 39th WEDC Conference, Kumasi, Ghana, 2016
- Government of Zimbabwe (2012) National Water Policy, Ministry of Water Resources Development and Management, Government of Zimbabwe.
- Government of Zimbabwe and UNICEF (2012) Improving Water, Sanitation, and Hygiene in Rural Areas of Zimbabwe: Strategic Concept Note and Programme Design, June 2012-2016.

## SUSTAINABLE SERVICES

### Private Sector, Public-Private Partnerships (PPPs), Public-Private-NGO Partnerships

National Action Committee (2015a), Documentation of PPP Models in 8 Districts, Government of Zimbabwe

National Action Committee (2015b), Zimbabwe Rural WASH Sub-Sector PPP Framework, Government of Zimbabwe.

UNOCHA (2009) Zimbabwe Cholera Update, Situation Report 15 July 2009

Zimbabwe National Statistics Agency (2012) Census 2012, National Report, Zimbabwe National Statistics Agency.

Zimbabwe National Statistics Agency (2014), Zimbabwe Multiple Indicator Cluster Survey (MICS), FINAL Report, Harare. Zimbabwe.

Government of Zimbabwe (2013). Zimbabwe Agenda for Sustainable Socio-Economic Transformation (ZIM-ASSET): Towards an Empowered Society and a Growing Economy. October 2013 – December 2018. Zimbabwe.

#### **Disclaimer**

*The views expressed in this paper are those of the authors and do not necessarily reflect the views of the government/organizations they work for.*

## SUSTAINABLE SERVICES

Private Sector, Public-Private Partnerships (PPPs), Public-Private-NGO Partnerships

# A systems approach to sustainable water operation & maintenance in Uganda

Type: Short Paper (up to 2,000 words)

### Authors

*Namwebe Mary*, WASH Advisor, GOAL Uganda,

Email: [mnamwebe@ug.goal.ie](mailto:mnamwebe@ug.goal.ie)

Telephone: +256774516542

### Abstract / Summary

Non-functional rural water sources are one of the most significant challenges to the water sector in Uganda. Currently it is conservatively estimated that 15% of water points are non-functional (MWE, 2014). GOAL Uganda is currently piloting a markets based operation and maintenance model in Bugiri and Namayingo with the intent to improve water point functionality. The model seeks address key system constraints identified by the market diagnostic survey namely; collection of water user fees, communities collect funds only when the source breaks down. The O&M model is based on three interrelated behaviour changes that are crucial to the success of a more sustainable operations and maintenance (O&M). These comprise of: Private sector to pilot the new maintenance and repair service contract model, Water user committees (WUCs) adopting a new mobile payment system and collect regular water fees, Government to increase its influence in regulation and enforcement of O&M.

### Introduction

According to a synthesis of relevant research by the Rural Water Supply Network (2009), approximately 36% of all hand pumps in rural sub-Saharan Africa are completely non-functional. This figure varies across contexts and likely needs to be updated; however, the overall picture is fairly consistent with more recent studies (Improve, 2015). Uganda is no exception, where the Community based management (CBM) model has been codified into law (MWE, 2011). Non-functional rural water sources is one of the most significant challenges to the water sector in Uganda. Currently it is conservatively estimated that 15% of water points are non-functional (MWE, 2014). Each bore hole costs approximately Ugx 24 million (\$8,000), representing a significant loss of investment, approximately \$30million<sup>111</sup>. While there has been significant progress in improving access to safe water, these gains are being undermined by an ineffective approach to water operations and maintenance. In Bugiri and Namayingo districts where GOAL Uganda is currently implementing the O&M pilot model the situation is not different while water coverage is low 44% and 33<sup>112</sup>% respectively, functionality is not good: Bugiri 86% and Namayingo 73%.<sup>113</sup>

In 2014, GOAL undertook a market analysis to better understand how we could support sustainable water O&M. The program was keen to test the common assumptions held by other development actors. The main ones were that poor functionality was caused by low availability of spare parts, weak capacity of hand pump mechanics and limited access to finance. We found that collection, management of user fees and lack of a maintenance service were the key issues.

To address the issues above GOAL Uganda is piloting a market based operation and maintenance model hinged on three inter-related behaviour changes.

Key findings from the market analysis undertaken in 2014 were;

<sup>111</sup> UWASNET, News letter , March 2016

<sup>112</sup> Ministry of water and environment sector performance report 2014

<sup>113</sup> ibid

## SUSTAINABLE SERVICES

### Private Sector, Public-Private Partnerships (PPPs), Public-Private-NGO Partnerships

- The availability of spare parts, technical capacity of mechanics and access to finances are not the key drivers of poor O&M performance.
- The main issues faced by communities are the collection of water user fees.
- Water User committee's (WUCs) have very limited funds in fact 62% of WUCs had no funds at all.
- Technicians (Hand Pump Mechanics) provide impromptu O&M services.
- The collection of funds to pay for repairs can take months.
- Water users see no reason to pay for services while the water point is working.
- WUCs find themselves scrambling to collect funds when the water point breaks down.
- There are very few disincentives for non-payment causing significant delays in repair times, leading to reductions in access to safe water.

### Context, aims and activities undertaken

GOAL Uganda with support from Charity Water is implementing a project named Sustainable Water Improvement Project (SWIM) planned to run for two years in the districts of Bugiri and Namayingo districts. The interventions focus on addressing three interrelated behavior changes that are crucial to the success of an alternative O&M model. The three behavior changes include:

- i. Water user committees adopt the new contract provided by the O&M service providers'

GOAL Uganda is working with an existing business to pilot a sustainable O&M service that has a greater focus on maintenance through the delivery of a fixed maintenance and repair service for all water points signed onto the O&M contract, in return for a standardized quarterly charge. Additionally, the pilot aims to demonstrate that provision of O&M services, can create profitable income for mechanics.

A business case was developed for a fixed maintenance and repair service. For communities who sign up to the O&M contract, they will receive a quarterly maintenance service and all repairs and spare parts; in return for a standardized quarterly fee of approx. \$70. In order to keep things simple while testing the model, the fee is standard across all community, large and small. If we can demonstrate demand for the service, additional refinements will be made in the future to reduce the fee for smaller communities.

The O&M service provider would be expected to raise revenue and hedge financial risk by aggregating WUCs into the system. The O&M service contract model assumes a conservative repayment rate with the costs for parts based on a breakdown of lifecycle costs, divided by yearly payments

- ii. WUCs adopt a new mobile saving system and collect regular water fees

The market research revealed that non-payment of water user fee is not directly linked to level of household income or ability to pay. 78% of WUC's said that lack of payment reflects an unwillingness, rather than an inability to pay for water. Our hypothesis is that, if there exists a transparent and secure system to save water user fees, more households will be willing to pay regularly for their water.

GOAL identified a mobile money provider Airtel, who have a mobile money wallet Airtel WEZA, which was originally designed for use with VSLA<sup>114</sup> groups, and has some additional accountability mechanism appropriate for group savings.

---

<sup>114</sup> Voluntary Savings and Loan Associations

## SUSTAINABLE SERVICES

### Private Sector, Public-Private Partnerships (PPPs), Public-Private-NGO Partnerships

GOAL and Airtel (a mobile telecom company) are working together, to increase adoption and enable WUCs to join the network of Airtel WEZA in Bugiri and Namayingo Districts. Airtel promoters are targeting the general community to increase demand for Airtel mobile money services so as to safely save and manage water user fees. This in turn enables them to have sufficient funds to pay the O&M service provider.

- iii. Government increases it’s influence in regulation of O&M service provider and enforcement of water user fee collection

GOAL is working with district local government (DLG) to support their regulatory and enforcement roles. The national government ties 70% of DLG WASH budget to new water and sanitation infrastructure, leaving only 30% of the budget for all other activities including repair and maintenance of water points and all other software activities. It is evident that unless there is a significant policy shift towards maintenance and repairs, LDG will never have the resources to pay for water point maintenance and repairs. Therefore its vital for the DLG to work in partnership with the private sector to leverage financial resources and expertise to address O&M issues which are underfunded. The SWiM project directly addresses this systemic issue by ensuring that LG regulates the O&M service provider and enforces the payment of wateruser fees.

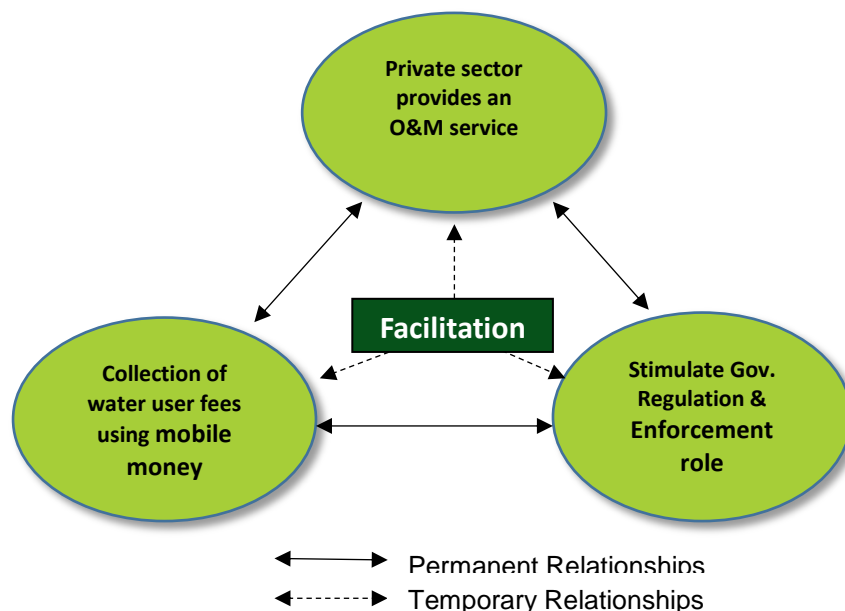

Figure 1. A three pronged approach to stimulate more sustainable O&M

Through the pilot project GOAL Uganda is stimulating community demand for O&M services to enable them pay for O&M services, whilst supporting a more sustainable O&M service.

### Main results and lessons learnt

The pilot project is still in initial stages so far we have preliminary results which cannot be confirmed until early 2017.

### O&M service provider has adopted and is marketing a new O&M service contract with WUCs.

GOAL Uganda identified GEMA Investments Ltd as the O&M service provider given their existing technical skills and experience in the provision of water maintenance and repairs, level of trust within the community and local government and the perceived ability to manage O&M services using a business model.

## **SUSTAINABLE SERVICES**

### **Private Sector, Public-Private Partnerships (PPPs), Public-Private-NGO Partnerships**

GEMA currently works with the best existing mechanics under an ‘out service’ model to provide services and geographic coverage across both districts. A total of six mechanics have signed an agreement to work with GEMA. To date GEMA has signed O&M contracts with 24 WUCs which have paid their first quarterly installment. The company has conducted 24 major repairs in the first quarter and 20 minor repairs in the second quarter for the boreholes.

GEMA is continuously promoting the O&M contract to communities and several WUCs will be signing contracts in the coming months.

#### **WUCs are adopting a new mobile payment system and collecting water fees.**

To date, 44 WUCs have been registered on Airtel WEZA, 28 are actively saving water user fees and the other groups are waiting activation. Airtel WEZA has enabled the WUCs to accumulate water user fees hence make payments to the O&M service provider. A total of UGX 2.9 millions (USD 906) has been saved on the airtelweza platform. There are some teething problems with the new wallet, and GOAL is working closely with Airtel’s regional and national agents to resolve these problems.

In addition, GOAL has recently significantly revised the WUC’s training. Training is now specifically targeted to early adopting WUC’s and is focused on collection of water user fees, linkages to O&M service providers and simple book keeping. Communities facilitate the training costs with GOAL / partner providing the trainer. This is considered central to increasing demand for reliable O&M services.

#### **Government has increased its influence in regulation of private sector and enforcement of payment of water user fees.**

GOAL Uganda supported GEMA to develop the O&M contract collaboratively with the government’s regional WASH Technical Support Unit (TSU) and Bugiri and Namayingo district local governments (DLG). The contract details the terms and conditions as well as roles and responsibilities for each party. The O&M contract was formally approved by Chief Administrative Officers of both district local governments.

In addition the district water officers of both districts have endorsed the memorandum of understanding (MOU) signed with GEMA and the mechanics as part of their regulatory role. The MOU details the terms and conditions of the contract and roles and responsibilities for both the mechanic and GEMA. The company is working closely with the district water offices and reports regularly on the O&M contract work.

#### **Conclusions and Recommendations**

GOAL introduced the service contract model in early 2015 and therefore is cautious to draw upon any results prematurely. Many preliminary activities were required to be undertaken before actual implementation, for instance, market research, developing a business model, partner identification and due diligence among others. However, GOAL plans to track the contracts signed, the satisfaction of communities, the length of interruptions to water service and the number of breakdowns fixed successfully. In addition, GOAL will track the number of WUCs signed up to Airtel WEZA and that are actively transacting.

The strategy for viability is that successful service providers will build on their reputation and grow the number of communities that they serve. To support and reinforce the relationship between service provider and communities, GOAL is working with the local government to help it play a stronger regulation and mediation role. As the provision of water is a public good, the mediation role involves agreeing to the service charge rate, ensuring that service providers provide a good service, and that communities continue to pay their regular fees.

#### **Acknowledgements**

GOAL Uganda would like to appreciate District local government, private sector partners and communities for the great collaboration. In addition GOAL acknowledges Charity water and Irish Aid for providing the financial support that has enabled her to undertake this work.

#### **References**

## **SUSTAINABLE SERVICES**

### **Private Sector, Public-Private Partnerships (PPPs), Public-Private-NGO Partnerships**

Ministry of Water and Environment,( 2014) “Sector performance report”

RWSN (2009) “Handpump Data 2009”,Selected Countries in Sub-Saharan Africa

Uganda Water and Sanitation NGO Network,(2016) ” Newsletter”

## SUSTAINABLE SERVICES

Private Sector, Public-Private Partnerships (PPPs), Public-Private-NGO Partnerships

# Steps to Sustainability: Public-Private Partnership in WASH

### Authors

*Adam Harvey, Joel Mukanga and Emma Goring*

*Adam Harvey, Director Whave Solutions, Uganda, [adam.harvey@whave.org](mailto:adam.harvey@whave.org), +256 782 846875*

### Abstract/Summary

Unreliable operation of clean water sources and inadequate hygiene and sanitation conditions are root causes of persistent water-borne disease. This paper presents a public-private partnership approach to rural WASH service delivery which addresses these issues through social, technical, financial and institutional initiatives. The approach has developed from stakeholder consultation, government partnership and extensive engagement with rural communities. A series of ‘sustainability steps’ have been developed from this practical base, which include projections of tariffs and financial viability for local service companies. Results are presented following extensive field work over three years in five districts. The conclusion is that sustainability can be demonstrated within several years, as long as the transition process starts with targeting of funding to pilot districts in which the local authorities normalise the approach by applying it universally. The pilot work would then be at sufficient scale for proof-of-concept and would establish templates and capabilities suitable for scaling nationally.

### Introduction



**Figure 1: Signing of a reliability assurance service contract.**

Whave Solutions registered as a Ugandan company in 2012, after a year of preparation in which the service company concept was developed as a solution to the problems of poor functionality and hygiene. The company was established as a non-profit, in order that credible monitoring could comprise a major part of its work. The goal was to provide rural communities with affordable water supply maintenance contracts which assure reliable supply of clean water, at the same time as providing services in hygiene and sanitation which would address drinking water contamination. Since 2012, under the programme entitled ‘Sustainable WASH Services’, service agreements have been signed with more than 200 communities (Fig 1). Local technicians have been contracted as service company franchisees and trained to undertake preventive maintenance, using daily supply reliability as a performance indicator. The problem of relapse following hygiene lift campaigns has been addressed by community grading, and initiatives have been taken in sanitation. The focus has been on government and community collaboration in the design of a road map toward locally-sustained, universal water supply and sanitation, both “safely-managed” in accordance with the Sustainable Development Goals 6.1 and 6.2. This road map includes all



## SUSTAINABLE SERVICES

### Private Sector, Public-Private Partnerships (PPPs), Public-Private-NGO Partnerships

technologies for rural water supply, with priority being given to piped systems which bring water closer to homes.

#### The approach - Building public-private partnership frameworks

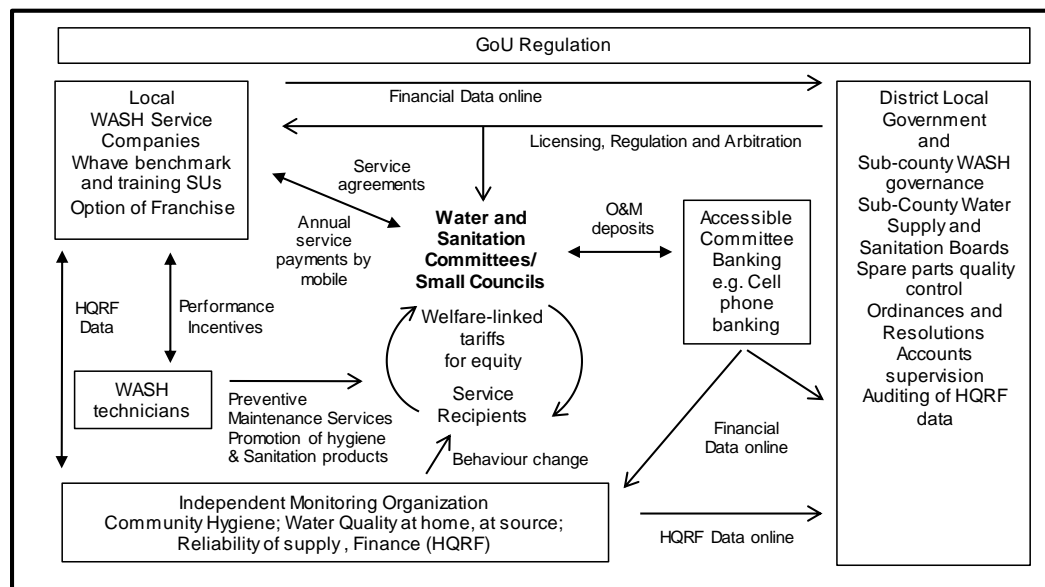

**Figure 2: WASH Public-Private Partnership Structure.** Some district authorities may expect Sub-County Water and Sanitation Boards to take the financial transaction and technician supervision role shown here for a service company. Stakeholder consultations however have indicated that most authorities will instead choose to regulate service companies.

The strategy adopted by the Whave Sustainable WASH Services programme involves district governments in building institutional structures to address health problems caused by endemic water-borne disease. The programme has worked alongside district governments to test initial approaches, and practical experience gained has led to the general framework shown in Figure 2..

As the programme evolves in forthcoming years, each engaged government is expected to develop its own variation of the public-private partnership (PPP) structure. The process can be described as a series of steps toward sustainability:

#### 1. Reliability assurance

A common attitude in sub-Saharan Africa in respect to groundwater pumps in rural communities is “wait-till-it-breaks”. This may be as much a result of policy which loads unrealistic expectations on rural communities as it is a cultural phenomenon or an outcome of dependency on government assistance and philanthropic hand-outs. The policy of Community-based Maintenance, for example, expects rural communities to identify suitable local technicians and pay them for maintenance and repair. During several hundred community meetings conducted by Whave since 2012, the weaknesses of this approach have been reported and described. Leaders have difficulty collecting tariffs because the technical work is often sub-standard, or the technicians’ professionalism is distrusted. Interviews with technicians have revealed that they were obliged to use substandard parts because adequate and timely payments were hard to obtain from the community, while interviews with community members showed that funds collected for O&M were often misused by Water User Committee members, so reducing motivation to pay tariffs.

To address these issues, Whave has introduced a system in which the transactional relationship is conducted not between the technician and the community, but between a service company and the water

## SUSTAINABLE SERVICES

### Private Sector, Public-Private Partnerships (PPPs), Public-Private-NGO Partnerships

committee. It then becomes the company’s responsibility to manage the quality of the technician’s work, not the community’s. The programme has investigated whether this approach reduces downtime and maintenance costs. Whave (acting as a prototype service company) offers communities reliability assurance service agreements, under which consistent water source functionality is provided in return for an annual service fee (*see Fig 1*). This represents a ‘business-for-development’ approach similar to health insurance: full payment is rewarded with full service and a smaller and incomplete payment receives less service. Revenues from service fees are used to pay local technicians, who are franchised (they carry the Whave badge when working) and performance-paid (*see Fig 2*). The franchise contracts incentivise preventive maintenance and immediacy of repair by imposing deductions on the technician’s monthly pay if a source in his concession (group of designated sources) is non-functional for more than one day. As a result, ‘down-time’ is avoided and costly major repairs are minimised.

#### *2. Universal access and responsible communities*

It is customary for community leadership committees to allow all community members access to a traditional water source, while their contributions to upkeep vary depending on wealth and consumption levels. However, modern machinery puts pressure on this approach due to the need for external technical input and specialist hardware, and the need for protection from theft, vandalism and misuse. All these pressures involve collection of cash payments from users, rather than the more traditional labour contributions. Cash payment cannot be imposed without the risk that many consumers continue to use “free” alternative sources, which are contaminated or time-consuming and dangerous to reach. Cash payments for water in trading centres in rural Uganda are typically in the order of \$5 per month per household (and often more than this), a price level which automatically excludes many families who choose instead to use contaminated sources and walk long distances.

To avoid this and secure universal access to safe water, a capable community water committee varies tariff contributions depending on what users can afford. Whave has found that rural committees in general have this capability and manage a welfare-oriented approach comfortably. While a Whave reliability assurance contract sets an annual bulk fee based on an average payment/household/month, the committee decides whether some users contribute more or less than an equal share, according to personal circumstances. An external body collecting data on varied tariffs is not found to be necessary, and in any case is unsustainably expensive. To monitor actual achievement of universal access as required by SDG 6.1/2, it is only necessary to survey villages and see if traditional universal access is being practised or not. Positive results to date imply that universal and reliable access to clean water does need a community committee as a responsible entity, and this feature of the Community Based Maintenance System (CBMS) should therefore be retained. While the implementation modality of CBMS needs radical revision, Whave and the Government of Uganda (GoU) do not promote removal of the policy altogether for this reason.

Retention of the CBMS has the implication that tariffs are set by communities, not by government. A precedent already exists for a compromise arrangement, which is that the district government passes a local law which accepts that all communities choose their tariff level, so long as it is above a specified figure. The example is Apac district, which resolved that all communities must pay between \$0.3 and \$0.6/hh/m into a maintenance fund, the rationale being that if there were few users and the community was remote and suffered high transport costs, they would choose to pay more than the minimum in order to be sure of enough funds. In this paper the mention of tariffs should therefore be taken as a reference to minimum tariffs, potentially set by district government laws. It should be kept in mind that not all community members are required to pay this average figure, given the welfare-orientated re-distribution described above.

Under CBMS, the maintenance fund belongs to the community, and is spent by the community on technical services of their own choosing. Currently, they may spend it on a service contract from a company like Whave, or on an individual technician checking a worn bearing or repairing a breakdown. However, there is scope within an improved version of CBMS for the district government to pass laws that require all communities to have in place a preventive maintenance service agreement, whether it be with an individual service provider (the ‘ISP option’) or a service company. Local laws of this type are relevant to the question of universal access, because the poorest families living in each village are the ones

## SUSTAINABLE SERVICES

### Private Sector, Public-Private Partnerships (PPPs), Public-Private-NGO Partnerships

suffering from prolonged repair times (they typically don't have a bicycle to fetch water from a distant pump and they tend to revert to collection from nearby contaminated sources). The measures described here to assure reliable operation and least life cycle cost are therefore critical to the SDG 6.1 goal of universal access and “safe management” of clean water sources.

#### *3. Professionalisation: roles, costs, tariffs*

For reliable clean water supply to be assured and sustainable, costs and revenues must be balanced and stable. A key objective of the programme is to investigate how this balance can best be achieved. On the one hand, costs must be well understood, while on the other hand an effective strategy for apportioning finance between user tariffs and government funds must be devised. One premise is that foreign aid has a role to play in early stages, but ultimately will not be a revenue source. A first stage has been the introduction of service companies and reliability assurance agreements in a PPP framework, as described above.

Costs divide broadly into the four categories of capital expenditure, minor operation/maintenance, major parts replacements and rehabilitations, and support (administrative, regulatory, management). Under current CBMS conditions, the roles of the main entities within the PPP framework divide as follows: (a) government and foreign development partners provide capital expenditure (fresh installations and full rehabilitation) and resources for correction of structural faults, for example silting and collapsed liners; (bi) local technicians collect tariff revenue from communities and use it to undertake skilled maintenance tasks and procurement/replacement of minor parts; (bii) major parts (for example pipes and rods) are replaced by government and foreign aid partners; (c) operational tasks are paid for, managed and conducted by the users, such as protection from misuse, vandalism and theft; (d) administrative, managerial, regulatory and compliance support is provided by local government.

Under the service company approach and the evolving radical revision of CBMS, known locally as 'Improved' CBMS (ICBMS), some of the tasks listed above are taken up by service companies. The financial transaction component of task (bii), for example, is undertaken by the service company. While technicians continue to undertake the technical work, they are supported in this role by the service company which has better engineering and hardware procurement capability. The service company also provides management and control of the quality of the technical work. Task (d) divides between local government and the service company, with local government focusing on regulation and the service company focusing on the management and administration for task (bii), as described above. The regulation role of the government includes support to tariff payment compliance and enforcement of relevant regulations, as well as arbitration and licensing of the service company. It also involves the monitoring service company performance, and further supportive activities, such as monitoring of water quality at the supply sources (stand-taps, supply tanks, hand-pumps, and shared treatment plant outlets).

The costs met by a service company are therefore not restricted to technical maintenance. Management is needed to ensure the quality of the work of local technicians and of collection of tariffs. Administrative costs are also associated with tariff collection. This “software cost” is likely to be around 60% of total service cost. This imposes an economy of scale, since management and administration costs are relatively fixed compared to technical costs which are typically proportional to numbers of sources maintained. A general consensus has arisen through community and government stakeholder meetings that a tariff of \$0.5/household/month is acceptable to communities and stakeholders. A cost study is under way which so far indicates that service cost can be targeted at this level, so long as local government capacity to perform regulation tasks is in place and effective. The programme aim is to see if this target can be achieved alongside the necessary local government capacity. Evidence to date on operational and administrative costs indicates that with tariffs set at this figure and successfully collected, a district-licensed service company will need to engage with a minimum of 400 communities in order to breakeven. A larger customer base will help to attain the target and introduce some margin. To put this figure in context, the average number of rural point-sources (not including protected springs) per district in Uganda is 715 (there are currently 112 districts in all). If full access to improved point-sources is achieved by all communities, the average increases to 1,084. Consequently, the tariff target of \$0.5/hh/m is more

## SUSTAINABLE SERVICES

### Private Sector, Public-Private Partnerships (PPPs), Public-Private-NGO Partnerships

likely to be achieved in practice if and when a service company achieves a larger customer base, ideally up to 1,000 communities.

However, this breakeven calculation assumes that the cost of major parts replacement (bii) continues to be met by government or with foreign aid, along with monitoring of source water quality at each source. Whave currently monitors water quality at sources and has found the cost of doing this adds 7% to the service cost.

One question posed by the investigation is: will a local service company have sufficient credibility to win the confidence of the communities when it comes to tariff payment? One solution may be that the local service company is a franchise business carrying the badge of a national or regional body. Although this approach may not turn out to be necessary, or may be useful only as a preliminary step, the priority of the programme is to build capability of local service companies to the point where they are directly trusted by communities. Failing this, franchising is likely to add 10% to the cost of providing service.

One of the key programme findings is that the current division of roles bi and bii is a cause of the “wait-till-it-breaks” syndrome. It cultivates a tendency to treat a pump as belonging to the organisation that installed it, and for routine maintenance to be ignored – why replace parts at your own cost, when government or an NGO is ready to replace a major component? An interesting finding has been that the inclusion of major components in a “full cover” maintenance contract adds only 20% to cost, under preventive maintenance conditions which avoid premature failure. If the tariff target is maintained at \$0.5, then the breakeven is no longer 400 sources but 600 sources. A larger customer base than this is of course preferable, and a service company will target regular tariff income from a whole district. The customer bases must be geographically concentrated to minimise transport costs and also to match licensing from individual sub-district governments (“sub-counties” in the case of Uganda). These findings have prompted the programme to prepare for a second stage in the sustainability process, in which the role bii is met by a service company rather than government/foreign aid organisations.

The problem of premature technical failure, unwillingness-to-pay and prolonged downtime, is not only the outcome of ineffective maintenance systems, but also of serious weaknesses in quality control of installations. Capital expenditure is poorly managed, with the result that most rural water sources suffer from sub-standard parts and materials, and many also from poor siting and design. The programme undertakes several measures to address this; for example by helping sub-county and district councils to establish quality-controlled depots and pass council resolutions which oblige technicians to use only approved parts. It also promotes change in the tendering process so that durability is not sacrificed to price. In the long run, a third stage in the financial sustainability path may become necessary as a further method of addressing this issue. This is the extension of the service company role into a “build-and-operate” modality, under which rehabilitation and construction is undertaken by the same company that provides service contracts. With appropriate license agreements in place for service companies, and appropriate performance monitoring protocols enforced, this approach will create an incentive for improved design and construction optimising life-cycle-cost and promoting least-cost tariffs.

In the short term, the problem of poor installation quality is an impediment to progress toward reliable rural water supply. The cost and revenue estimates set out above assume that the water source technologies are in reasonably good shape at the point at which reliability assurance service agreements are signed; only then does it make sense to “insure” the sources at the target tariff level. The Whave programme therefore assumes that capital is available for refurbishment and upgrading. This highlights the importance of foreign aid assistance which has a critical role of upgrading installation quality and design. The programme promotes an approach whereby rehabilitations assisted by foreign organisations are combined with community preparation for preventive maintenance service contracts, as well as by preparation of the district and sub-county government offices for stocking of spare parts and appropriate regulation capacity. This will mean that once the maintenance system is built properly at district scale, further rehabilitation expenditure will not be needed. The GoU is taking the Whave programme seriously because it promises to relieve the large sums devoted to rehabilitation each year; these sums may now be now earmarked as funds for support to the PPP framework for preventive maintenance and continuous renewal of major parts by the communities themselves.

## SUSTAINABLE SERVICES

### Private Sector, Public-Private Partnerships (PPPs), Public-Private-NGO Partnerships

Cost analyses which is cautious as to the practical feasibility of establishing all the measures mentioned conclude that the indicative tariff level needs to be approximately \$1/hh/month (Harvey 2015, Biteeff 2013). This level would allow service companies to interact much more with communities, so increasing tariff compliance. Because this \$1 tariff level is so much less than the \$5/month commonly paid by rural families at trading centres for filling of jerry-cans, and is less than 2% of average rural household income in Uganda (\$73.1) it could be acceptable to communities (UNHS, 2010). However, outcomes from meetings for local politicians and community meetings in which the feasibility of this higher tariff has been debated extensively, suggest that the \$0.5 tariff is already ambitious from a political acceptance point of view and it is the only realistic target currently. Nevertheless, as the supporting environment is developed, this figure could be revised. Service companies may not be viable at this lower level of revenue, and a rebate from tax-payer sources matching community payments and based on monitored performance could be a necessary.

Whave’s monitoring protocols prepare for implementation of this results-based subsidy option. To begin with this option is avoided and the emphasis is on service companies operating on the basis of tariff revenue, and tax-payer funds meeting only government support costs (also as far as possible using results-based rebate approaches). There is however the possibility that government support effectiveness will be limited and funds could be more effectively spent on results-based rebates for service companies. The programme is open to these options evolving with different solutions in different districts and even different sub-counties, since this approach aligns with GoU decentralisation policies and ensures that regulation has a high level of “ownership” and “buy-in” at local level. Currently GoU has recommended that tax-payer funds are channelled to sub-counties as well as districts. It has also recommended establishment of sub-county water and sanitation boards, and has encouraged local technicians to form associations which are permitted to take on rehabilitation contracts. These are all strong moves towards local discretion in regulation modalities.

#### *4. Measures promoting willingness-to-pay*

The rural tariff of \$0.5/household/month is politically acceptable and much less than the \$5 typically paid at stand-taps, yet there is still insufficient willingness-to-pay this amount within communities. The Whave programme is implementing several measures to improve the situation, integrating these with development of local government regulation capacity. Some examples are: (a) radio call-in discussions debating tariffs and their purposes which involve civil society, farmers, politicians, and civil servants; (b) introduction of telephone banking for community water committees, and (c) promotion of council resolutions. The latter might, for example (i) make committee bank accounts containing maintenance deposits obligatory, in order to reduce costs of transactions and to improve accountability; (ii) certify technicians and oblige them to use only approved hardware; (iii) oblige committees to have active preventative maintenance service agreements from approved and licensed technicians; (iv) prohibit or discourage expenditure on rehabilitation from external sources such as local government or voluntary agents, in cases where preventive maintenance activity has not been demonstrated for a period of time, and (v) institute independent performance monitoring agents and protocols which act as a basis for licensing of preventative maintenance service providers.

## SUSTAINABLE SERVICES

Private Sector, Public-Private Partnerships (PPPs), Public-Private-NGO Partnerships

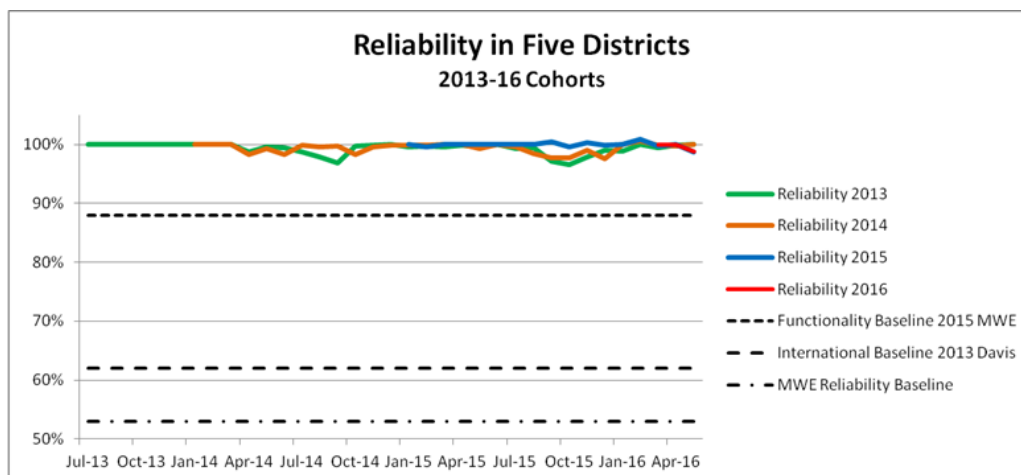

Figure 3: Reliability in five districts – 2013-16 cohorts

The current lack of willingness-to-pay is attributed by most observers to a lack of accountability. Almost all communities have stories of maintenance funds being borrowed by committee members and not returned. Communities also frequently mention technicians doing sub-standard work or over-charging. Families are not likely to pay for preventive maintenance unless the payee is fully trusted. Whave has overcome the technician problem by controlling the quality of their work. However, trust in local service companies (and individual service providers) may prove to be a problem. The introduction of phone banking potentially offers a solution and so may be a key to building willingness-to-pay. Telephone transfers and online bank accounts can be tracked and supervised. The community committees’, the technicians’ and the service companies’ bank accounts can all be visible to each other and to local government regulators and arbitrators, also to an independent monitoring body. Payments can be made and receipted without cash being handled, so saving travel expenses and maintaining transparency. Spare parts quality control is more easily managed as expenditure from bank accounts can be conditional on approval, ensuring that the approved parts are purchased at approved prices. Whave has signed a collaboration agreement with Post Bank under which it facilitates sub-county registrations of committees and their opening of telephone banking accounts.

### 5: Continuous and independent monitoring

The results presented below (see Fig 3) demonstrate that certain monitoring indicators are effective, and their application is affordable; their introduction is a key sustainability step. The purpose of a new performance indicator for “reliability”, innovated by Whave, has been described above. This has provided a basis for performance-payment of technicians, as well as offering a basis for licensing of service providers (companies or individuals). The reliability indicator measures the portion of time lost in prolonged repair down-times by “partially functional” sources. For example, a water source that is operational for 15 days through a month containing 30 days has reliability score that month of 50%.

Testing of source water quality is also recommended as a permanent part of the WASH PPP structure. This is necessary to determine which technologies and designs are effective in providing clean water, as well as to steer corrective action. Source quality monitoring results are shown in Fig 4.

Monitoring has important potential for achievement of SDG 6.2. Clean water supply by itself does not solve the water-borne disease problem unless it is supplied in adequate quantity or very near homes, prompting hygienic handling. In the case of the majority of families in sub-Saharan Africa who are unlikely to have piped supply for many years, hygienic handling of water is critical if the intended health and productivity benefits of an improved source are to be obtained. The programme has introduced two indicators for hygiene and sanitation: home drinking water faecal contamination and community hygiene grades. It may take some years for hygiene and sanitation conditions to be transformed entirely, or for piped supply to replace hand-pumps, after which time these indicators may no longer be needed.

SUSTAINABLE SERVICES

Private Sector, Public-Private Partnerships (PPPs), Public-Private-NGO Partnerships

However, until that time they are necessary as permanent elements in the PPP structure and their monitoring should be continuous and institutionalised.

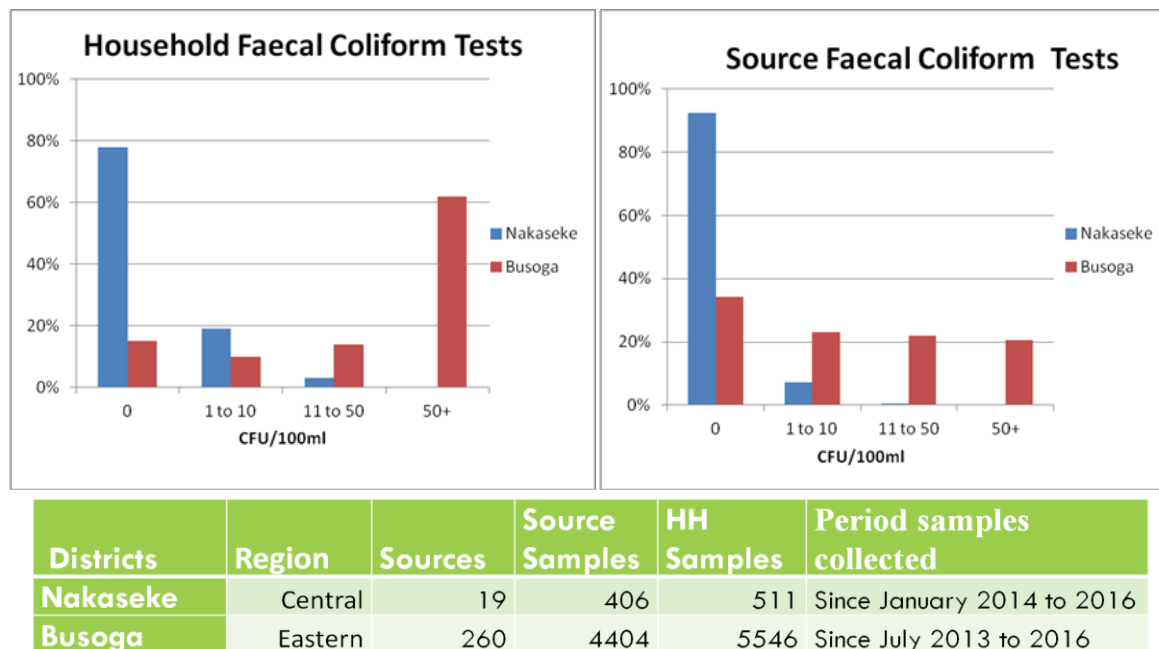

Figure 4: Faecal coliform tests in five districts comparing regions.

The home drinking water quality indicator has proven effective during the past three years. It has revealed serious issues with current professional practice. Latrines are mandatory, but little thought or action has gone to cleansing methods, encouraging contamination of household stored drinking water, as shown in Fig 4. Whave has consulted rural families about their traditional hygiene methods and is encouraging a return to abandoned cleansing methods, which have been dropped in pursuit of modernity.

In regions where scooping from storage pots with cups is practised, only 25% of households meet the WHO low risk threshold for drinking water quality (<10cfu/100ml), compared to 97% of households in non-cup-scooping regions. Finger-dipping when removing water from the pots with cups has been observed during hygiene grading surveys as a common occurrence. This result has led to Whave editing professional outreach manuals (which illustrate cup-scooping) and encouraging a return to ladles. In addition, Whave is training local potters to make and sell a modified pot which has a tap and a narrow neck, preventing cup-scooping. The pot has proved inexpensive and affordable, and is purchased at full cost.

The community hygiene grade indicator has also generated significant results. Homes are randomly selected on random dates each month, and surveyors are trained to record observations, rather than replies to questions. A full range of hygiene behaviours are surveyed, so that the data collected works to identify where interventions are needed. Expensive investments in hygiene lift campaigns are invalidated by the prevalence of ‘relapse’ – new behaviours fade and old habits are reinstated. The 2010 Cochrane Review reported interventions “waning over the long term” (Gould et al, 2010; Pfoh et al, 2013), and an IRC (2004) study showed hand-washing skills in Uganda decreased significantly within one year following uplift. Results from three years of hygiene monitoring are shown in Fig 5 for over 200 communities. Instead of relapse, these records show retention of hygiene up-lift. Regular monitoring acts as a reminder visit to a community: it sustains improvements as no family wishes to be caught out. The programme is planning a competitive league table, encouraging pride in better hygiene and using competitive events and radio exposure to foster improved hygiene levels.

SUSTAINABLE SERVICES

Private Sector, Public-Private Partnerships (PPPs), Public-Private-NGO Partnerships

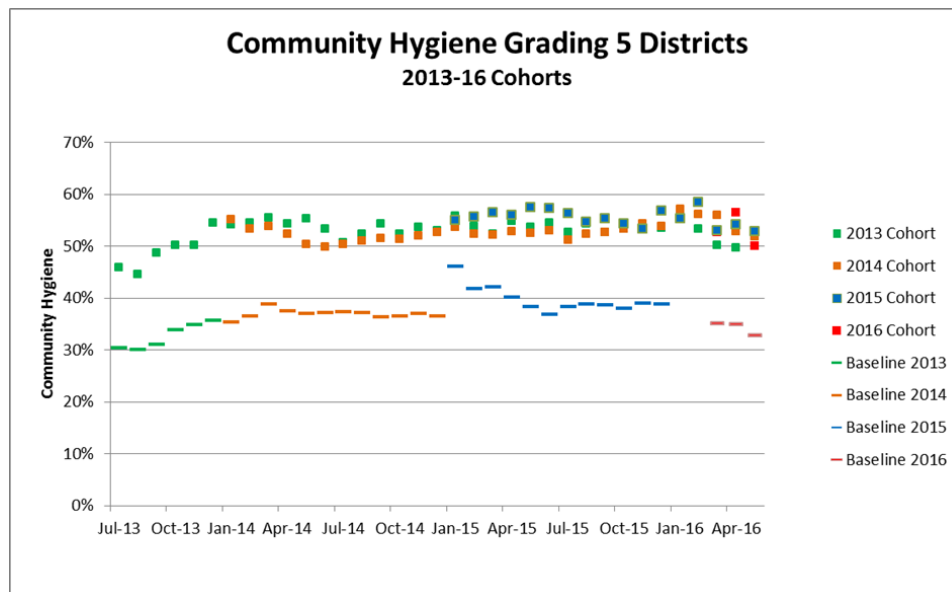

Figure 5: Community hygiene grades in five districts – 2013-2016 cohorts.

Results and Lessons Learned

Fig 3 shows reliability baselines and results over a period of years following annual cohorts of communities signing into reliability assurance agreements. The separation into cohorts reveals whether or not reliability drops over time, which may be expected since a reliability assurance agreement is usually started with refurbishment of the source, so few problems would be expected in the first year. In comparison to baselines estimated at 50-60% (Davis, 2013) and conversations with GoU engineers, reliability of water sources in more than 200 communities has remained above 99% over three years. The lesson learned here is that performance payment of technicians is effective – it achieves reliability. This result also confirms the ideal that rehabilitations will eventually not be needed, but water sources will be kept running indefinitely without excessive appeals for foreign aid or strain on the GoU rehabilitation budget.

Fig 4 shows that home contamination is a far more serious issue than is commonly acknowledged. These results should act as a trigger for investment in improved health outreach protocols to balance investments made in improved and more reliable water supply. Equally, the data shown for source quality is a cry for action. In this case, GoU has become aware of the situation and is taking measures, for example deciding that government will no longer fund hand-dug or shallow wells. However, NGOs continue to install similar ground water facilities and there may be insufficient awareness of water quality. Whave is developing low cost water treatment plants in response to this issue.

Fig 5 shows that hygiene levels rose by an average of 16% as a result of initial campaigns at time of service contract signing, and this gain has been sustained over three years, without relapse and without any intervention other than regular monitoring. Again, the information is separated into cohorts, so the tendency for “older” communities to relapse, can be inspected.

The lesson learned in respect to the monitoring work is clear – regular and continuous monitoring is essential if water-borne disease is to be eliminated. Data collected allows interventions to be targeted and erroneous investments and measures to be revealed. The process of tracking also drives and sustains desired behaviour change.

To establish sustainability in one pilot district will not be a fast process and it is estimated that the multiple measures described above will take four years to implement with sufficient funds available. During this period, officials from other districts would be involved, and professional capability for



## SUSTAINABLE SERVICES

### Private Sector, Public-Private Partnerships (PPPs), Public-Private-NGO Partnerships

replication would be developed alongside template contracts – a national scaling programme would then be feasible in subsequent years.

Are water users content with reliability assurance agreements? This question will be answered through public debate in forthcoming years. The planned radio talk-shows will provide feedback and evolving community willingness-to-pay will be the principle test. Currently, the programme engages 150 communities graduating probation stages to full annual service agreements and paying their annual subscriptions. Most of these communities include individuals who resist payment (often quoting politicians who have claimed votes by promoting “free” water) and some committees struggle to pay the annual bill in the face of the resistance. The programme therefore aims to normalise payment and secure quality of service, through geographically concentrated expansion of scale throughout a whole district, and through introduction of all of the measures described above. The lesson learned is that consumer willingness-to-pay is a participatory process that has started but will not yield positive results unless the multiplicity of steps described here are implemented at appropriate scale, which is estimated as a minimum of 600 neighbouring communities.

### Conclusions and Recommendations

A full suite of measures are needed to establish reliable rural water supply and transform hygiene conditions, in order to address water-borne disease sustainably. These measures can be summarised as a series of sustainability steps, including establishment of regular monitoring of key indicators, performance payment of local technicians, and new initiatives in hygiene and sanitation. The measures will be effective if introduced through public-private partnerships in pilot districts where economy of scale is achieved (engagement of more than 600 neighbouring communities) and where the district government introduces the appropriate support measures including support to tariff payment compliance. This process will need considerable funding, but will result in achievement of a proof-of-concept for sustainability and the prospect of national roll-out and international example.

### References

- Biteete et al (2013) Life-Cycle Cost Analysis of Rural Water Supply in Uganda  
<http://www.waterservicesthatlast.org//media/publications>
- Davis, S. (2013) Guidelines for Resolution of Problems with Water Systems. Improve International. Available at: <https://improveinternational.files.wordpress.com/2014/10/resolution-of-problems-with-water-systems>
- Gould, D.J, Moralejo, D., Drey, N. & Chudleigh, J.H. (2010) Interventions to Improve Hand Hygiene Compliance in Patient Care. Cochrane Database Systematic Review (9).
- Harvey A, Mukanga J, Waibi J, (2015) Public-Private Partnership Model for WASH Effectiveness, 38th WEDC International Conference, Available at [www.wedc.lboro.ac.uk/resources/conference/38/Harvey-2271.pdf](http://www.wedc.lboro.ac.uk/resources/conference/38/Harvey-2271.pdf)
- IRC (2004) Sustainability of Hygiene Behaviour and the Effectiveness of Change Intervention – Booklet 2. International Water and Sanitation Centre. Available at: <http://www.ircwash.org/sites/default/files/booklet2.pdf>
- Pfoh, E., Dy, S. & Engineer, C. (2013) Chapter 8 - Interventions to Improve Hand Hygiene Compliance: Brief Update Review. In Agency for Healthcare Research and Quality (US) (Ed.) Making Health Care Safer II: An Updated Critical Analysis of the Evidence for Patient Safety Practices. Evidence Reports/Technology Assessments, No. 211.
- UNHS (2010) Uganda National Household Survey Report 2009/2010. Uganda Bureau of Statistics.

## SUSTAINABLE SERVICES

Private Sector, Public-Private Partnerships (PPPs), Public-Private-NGO Partnerships

# Sustainable WASH Services for Complex Emergency Countries: Approaches from the Central African Republic

Type: **Short Paper**

### Authors

1. David DeArme

Country Director

Water for Good

Based in Lyon, France

[ddearmey@waterforgood.org](mailto:ddearmey@waterforgood.org)

(FR) \*00 33 770 94 63 62 | (CAR-RCA) 00236 75 29 27 95

2. Adrienne Lane

3. Jon Allen

### Abstract/Summary

Water for Good is an international NGO with 12 years of experience in the water, sanitation and hygiene (WASH) sector in the Central African Republic (CAR). This paper aims to highlight a practitioner’s approach for reliable WASH access and services for rural water users in a complex emergency context. Specifically, Water for Good has developed a circuit-rider model for integrated monitoring and post-construction support. This approach to rural WASH services can be an effective, affordable, and appropriate response to conflict and humanitarian crisis. This paper aims to illustrate what is possible in difficult conditions, including protracted civil conflict. In spite of the instability that CAR has experienced, over one quarter of the country’s rural water points are regularly maintained with functionality rates over 85%.

### Introduction

The rural people of the Central African Republic (CAR) are among world’s most vulnerable populations. In the last three years the county suffered a coup ‘d’état, resulting in an unprecedented displacement crisis and humanitarian disaster. Even before the recent conflict, CAR suffered insecurity and low levels of water sanitation and hygiene (WASH) access.

Water for Good highlights sustainable WASH activities that have proven effective in the midst CAR’s complex emergency. Specifically, this paper examines the effectiveness of the circuit-rider model for integrated maintenance, repair, and monitoring services for existing infrastructure.

The Central African Republic may seem like an edge case or unfit context in which to develop models for sustainable WASH services. However, the international community has committed to universal WASH access and the Sustainable Development Goals, necessitating strategies to creatively engage with people and governments facing complex emergencies. This paper aims to illustrate what is possible in difficult conditions and the preliminary results are promising. Water for Good’s circuit-rider program in CAR reaches over one quarter of the country’s rural water points are regularly maintained and electronically monitored, with functionality rates over 85%.

Water for Good has the unusual perspective of a locally staffed, private, international non-profit with a long-term presence in CAR. This organization has had to adapt to the fluctuating international NGO/humanitarian interest in CAR, as the situation changed from chronically under-resourced and un-

## SUSTAINABLE SERVICES

### Private Sector, Public-Private Partnerships (PPPs), Public-Private-NGO Partnerships

stable country to a crisis/conflict zone. Water for Good can speak to the changes in operational realities and the changes in the NGO/funding ecosystem in CAR over that period. Ultimately, Water for Good advocates for increased international interest in CAR’s recovery process and, broadly speaking, for investment in sustainable WASH services across Sub Saharan Africa and other complex emergency countries.

#### Context, aims and activities undertaken

##### About Water for Good

Water for Good submits this case study from the perspective of a non-profit organization with the mission to create viable private sector solutions to water infrastructure problems in complex emergency countries. Water for Good has 12 years of experience in the Central African Republic, focused on borehole drilling, private sector supply chain development, professionalized hand-pump maintenance services, and WASH training.

Currently, Water for Good has the capacity for rural water provision (borehole drilling) and service delivery (through a circuit rider program) in the Central African Republic. In addition, Water for Good collects electronic functionality data from a network of over 1000 hand pumps.

##### CAR Context

To briefly describe the operating environment, the CAR conflict and ensuing humanitarian emergency escalated in December of 2012 when rebels from the north threatened to take the capital city. By March of 2013 the rebels successfully led a coup d’état, which quickly devolved into widespread looting and violence against civilians. The rebel groups leading the coup were majority Muslim. In response, starting in Jan 2014, self-defense groups and militias from the majority Christian/non-Muslim population led indiscriminate attacks against Muslims civilians and combatants. Religious identities became a common fault line for violence, approaching the severity of an ethnic cleansing of Muslims from the country.

The impact has been that roughly 20% of the population is still displaced and over half of the population is in need of immediate humanitarian assistance (UNOCHA CAR, 2016). However, it is important to remember that baseline access to water and sanitation was very low before the conflict—already at crisis levels (AMCOW Country Status Overview, 2011).

#### Main results and lessons learnt

Within that context, Water for Good has pursued a circuit-rider model for monitoring and maintenance of existing rural WASH infrastructure. This approach is described in greater detail, with the major emphasis on the electronic functionality data from the circuit rider program. There is also a discussion of Water for Good’s forthcoming strategy to expand professionalized post-construction support to all rural water users in CAR.

##### Circuit rider model for maintenance of existing WASH infrastructure: Program Description

Water for Good operates a large-scale circuit-rider model for hand pump maintenance across the southwestern regions of CAR. The program started in 2004 and was expanded to currently cover seven prefecture. Electronic reporting started in 2012. At its current scope, four professional teams travel predetermined routes that reach all pumps enrolled in the program, aiming to visit each water point twice per year. Communities in the seven prefecture where we operate are given the opportunity to enroll in the service after Water for Good rehabilitates or installs their hand pump. Communities with pumps installed by other organizations can also enroll. Each team includes three staff members: a technical lead, a technical assistant, and a community trainer who meets with well committee members and completes the iPad based reporting on-site. Staff members travel together in trucks, transporting a large stock of typical pump replacement parts. This, each team functions as a mobile supply chain of both replacement parts and expertise.

## SUSTAINABLE SERVICES

### Private Sector, Public-Private Partnerships (PPPs), Public-Private-NGO Partnerships

Once on site at a community hand pump, the teams complete performance checks and provide repair services, monitoring the functionality of the pump on arrival, the parts used (if any) and the pump functionality upon their departure. Communities pay a monthly fee of 8.00 USD for maintenance services, however at the height of the conflict, Water for Good halted all fee collection. In 2016 teams expect to collect 11,500 USD.

Water for Good monitors program activities utilizing electronic, on-site reporting, completed during each maintenance visit. Maintenance teams travel with iPads and they enter the required data into the customizable iFormBuilder™ reports (Zerion Software, Inc., Herndon, VA). Reports automatically record GPS locations and require teams to collect photographic evidence of work, details on repairs, community survey responses, and interviews with community leaders. This data is either uploaded back at operational headquarters or real-time when GSM coverage is available. This process allows for multiple reports and surveys to be completed offline and stored on the device. Once the team reaches a wireless connection, they upload all reports to a cloud-based server, allowing for rapid access and analysis of the data. This data is all linked to the community record and sorted automatically into our database. All trip plans and completed trip reports are submitted to the CAR government agency, ANEA, and the WASH Cluster.



Figure 1. Above left, circuit-rider team pulling a pump out. Above right, circuit-rider team members with their truck, stocked with hand pump replacement parts.

## Program Results

The maps and charts below demonstrate the program scope, costs, and results illustrated through summary of the data collected with the iPad based reports.

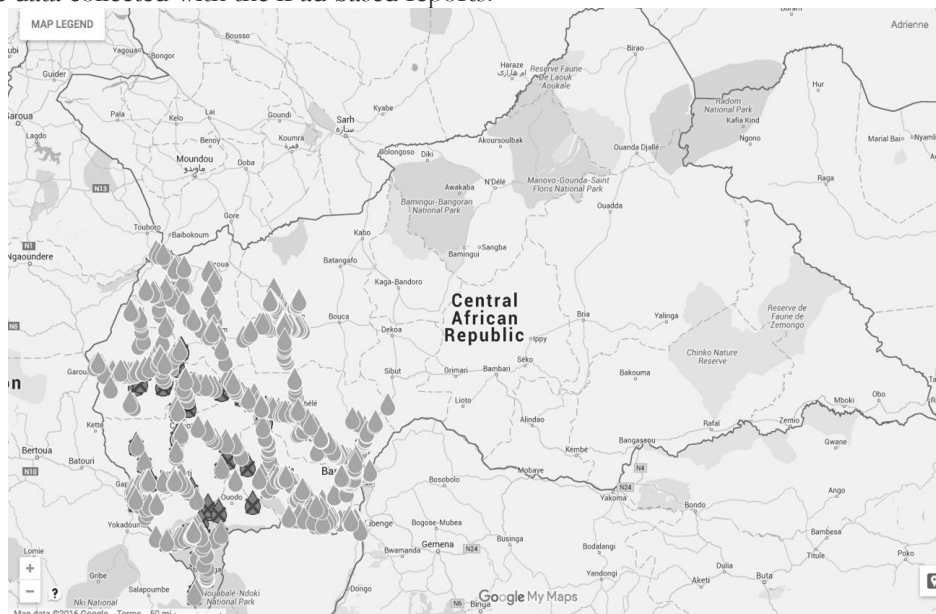

## SUSTAINABLE SERVICES

### Private Sector, Public-Private Partnerships (PPPs), Public-Private-NGO Partnerships

Figure 2. Map of the Central African Republic highlighting the locations of all the hand pumps Water for Good's circuit-rider program has serviced in the last 12 months.

#### Costs (all currency USD)

- 2015 total circuit rider program costs - \$209,566
- 2015 number of people reached - 673,083
- 2015 number of wells maintained - 1,115
- 2015 cost per water point - \$187.95 per year
- 2015 cost per person - \$0.31 per year

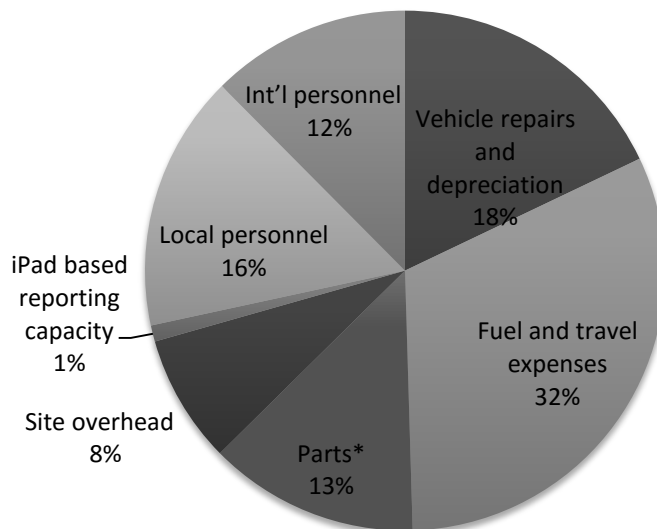

Figure 3. Cost Drivers

\*Parts expense in 2015 are lower in this graphic than actual use. Parts inventory carried over from the previous year.

Table 1: Circuit Rider Program Results 2012-2015

Year	Number of Sites	Number of Visits	Functional on Arrival	Functional on Departure
2012	863	959	86%	93%
2013*	687	921	82%	94%
2014*	893	1446	88%	94%
2015	1115	1953	88%	93%

For all results above, the data are pulled from electronic field reports completed by Water for Good maintenance staff, on-site, at the time of the maintenance visit. “Functional on Arrival” refers to the condition on the hand pump upon the arrival of Water for Good maintenance teams. “Functional on Departure” refers to the condition of the pump after the service visit and captures whether or not any non-functional pumps are repaired during service visits. Functionality on departure is not 100% for two main reasons: 1.) There are a set of pumps in the dataset that are non-repairable through the maintenance program interventions. By the end of 2016 we plan to scrub those sites from the program and slate them for decommissioning or rehabilitation. 2.) Teams occasionally lack the parts required to make repairs due to

## SUSTAINABLE SERVICES

### Private Sector, Public-Private Partnerships (PPPs), Public-Private-NGO Partnerships

an underestimate of part needs in their trip preparations or delays in part orders (all replacement parts are imported into CAR).

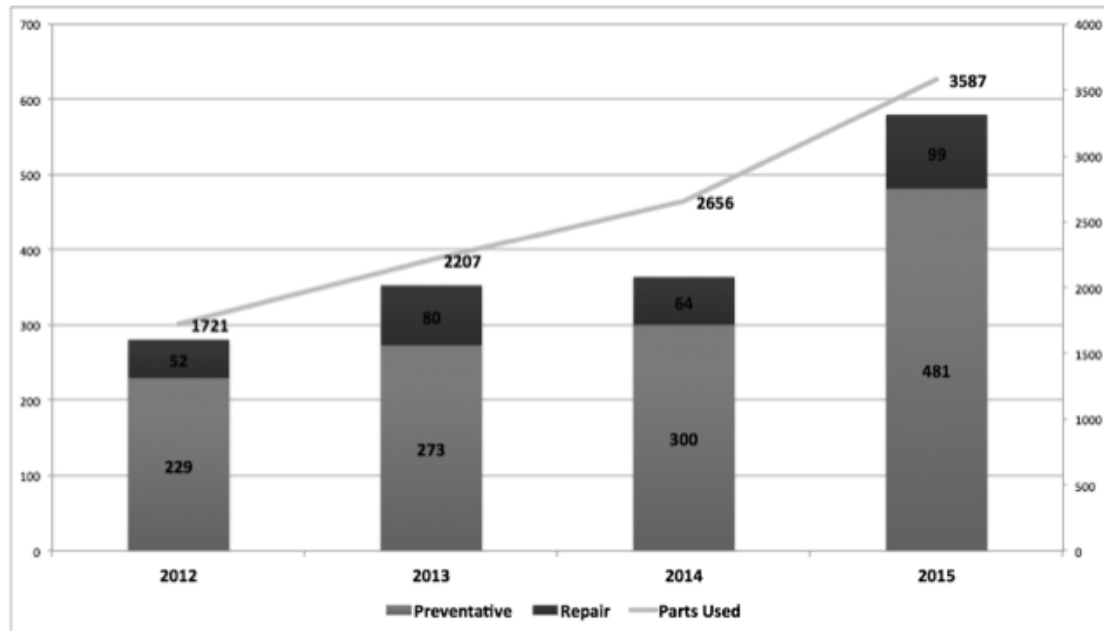

Figure 4: Visits Resulting in Preventative Maintenance vs. Repairs

**Table 2. Visits Resulting in Preventative Maintenance vs Repair.** The electronically collected field reports are the source of this data. “Parts used” refers to any pump part used during a given field visit. Visits are considered “Preventative Maintenance” if the pump is functional on arrival and departure. Visits are considered “Repair” if the pump is non-functional on arrival and functional on departure. Pump types are majority Vergnet foot pumps and a smaller proportion India hand pumps.

### 2015 Cost-Recovery

- Communities making a payment - 21% (233)
- Total community contributions - \$8,450 USD
- Percent of program costs covered by communities - 4%
  - The program is subsidized by philanthropic funding. Currently charity: water, based in NYC, USA and Living Water Interantional, based in Houston, TX, USA are the major contributors to this program.

### Program Impact

The maintenance visits have had a substantial impact on functionality, with rates well above regional averages and expectations (RWSN, 2009). Furthermore, the impact of this work is magnified in the midst of conflict; many of these pumps are located in “host communities,” where people fleeing conflict (IDPs) have relocated. As populations shifted in the conflict, water points would come under increased stress from IDPs. Water for Good helped keep pumps working, assisting host community resilience.

## Conclusions and Recommendations

### Evaluation and Future Plans

Water for Good is in the process of developing a Theory of Change (TOC) and five year strategy to expand and adapt the model and institutionalize post-construction support for rural water users in CAR. The Theory of Change aims to chart a path forward that is less dependent on unilateral/direct NGO service provision. The strategic development in this direction is in part a response to the research and advocacy in the sector, including the Triple S Initiative and the Agenda for Change with a focus on country-

## SUSTAINABLE SERVICES

### Private Sector, Public-Private Partnerships (PPPs), Public-Private-NGO Partnerships

wide harmonization and scale, calling on NGOs to engage governments at all levels (IRC, 2015, Agua-Consult, 2015).

Currently, four areas of activity are identified that will be critical for long-term sustainability:

1. **Develop a scalable service model.** As stated above, Water for Good already operates a circuit-rider model for post-construction support that covers over one quarter of the country's rural water points. Going forward, this model needs to be vetted for scalability, informed by a proof of concept in one prefecture (i.e. state), Mambere-Kadei. The proof of concept that Water for Good is designing aims to expand access and services to 100% of residents in that region by 2020. The long-term goal is the expansion of reliable post-construction support (through blended circuit-rider models and artisan repair activities) to all rural water users in CAR.
2. **Incubate private sector supply chain and service providers.** The long-term sustainability of a system for rural water access and services will depend on local access to replacement parts and water sector expertise. Water for Good has historically served as a proxy-private water well driller and parts supplier in CAR. Water for Good has owned and operated multiple field offices/properties, trained and retained drilling staff, and managed the importation of drilling assets, supplies, and manual pump parts. In 2015, Water for Good initiated the first phase of a long-term exit strategy that builds the capacity of the local private sector. This started by establishing a locally owned, for-profit drilling operation in partnership with a former staff member and lead driller. Water for Good has been incubating his company, Marcellin African Drilling. The next phase will include the incubation of a local pump parts distributor.
3. **Harmonize sector activities and evaluation standards.** UNICEF and the national rural water agency aim to coordinate humanitarian and development actors in the WASH sector. There is still low capacity. Since Water for Good currently has the largest scope of post-construction support and monitoring, it is imperative that the role of information-sharing increase, helping build the capacity of the sector in CAR to harmonize field assessments and activities.
4. **Institutionalize support and financing for rural water services.** In order to institutionalize any of the progress made in the provision of post-construction support for rural water points in CAR, Water for Good will work to increase capacity to advocate within the humanitarian sector and the public sector at national and regional levels.

### Conclusion

This paper has aimed to provide insight into the opportunities for effective, sustainable WASH services, even in the challenging, emergency circumstances. Water for Good invites critique and inquiry regarding the current structure and proposed future direction of the circuit-rider model rural water services in the Central African Republic.

In conclusion, Water for Good advocates for your concern and desire to work in hard to reach places like CAR. In order to achieve the sustainable development goals – to “leave no one behind” – WASH practitioners have a clear mandate to develop strategies that will work to reach remote, conflict-affected communities.

### Acknowledgements

This paper is adapted from earlier versions published on WASHFunders.org and presented at the 2015 UNC Water and Health Conference.

While many communities pay a fee for maintenance services, the bulk of the program's funding is subsidized through philanthropic partnerships: charity: water, Living Water International, and Water for Good's supporters.

## SUSTAINABLE SERVICES

Private Sector, Public-Private Partnerships (PPPs), Public-Private-NGO Partnerships

### References

AguaConsult, IRC, Water for People, WaterAid (2015) “Agenda for Change”

<http://www.ircwash.org/resources/agenda-change-achieving-universal-access-water-sanitation-and-hygiene-wash-2030-principles>

AMCOW (2011) *Country Status Overview CAR*. See: <https://www.wsp.org/sites/wsp.org/files/publications/CSO-CAR.pdf>

IRC (2015) Triple S Initiative. For more details see: <http://www.ircwash.org/projects/triple-s>

RWSN (2009) *Handpump Data 2009*. Selected Countries in Sub-Saharan Africa , RWSN , St Gallen, Switzerland

UNOCHA (2016). Humanitarian Bulletin Central African Republic. Issue 10 April 2016. See:

<http://www.unocha.org/car>



## SUSTAINABLE SERVICES

Private Sector, Public-Private Partnerships (PPPs), Public-Private-NGO Partnerships

# Providing handpump spare parts within 24 hours through the private sector

### Authors:

Cameron McDonald<sup>1</sup>, Samyuri Mumuni<sup>1</sup>, Patrick Apoya<sup>3,1</sup>, Albert Ekuful<sup>1</sup>, Marieke Adank<sup>2</sup> -  
<sup>1</sup>SkylFox Limited Ghana, <sup>2</sup>IRC Ghana, <sup>3</sup>Chartered Institute of Administrators and Management Consultants, African Health Economists Association

### Abstract

This paper tells of a company in Ghana building a business providing rural communities with better access to handpump spare parts. A mobile phone platform was developed to reach rural customers and fill the need for better distribution without the need to build costly physical locations. This mobile phone technology serves as an entry point into an untapped customer base and a gateway into other business ventures. The company is positioning itself as the only supplier to rural communities of several water, sanitation and hygiene items.

### Introduction

Edward D. Breslin, CEO, Water for People, says it best, “...*the images that dominate [the media] - pictures of children happily gulping water from a new tap- do not tell the whole story. The real image should be the one that plays itself out every day all over the world....of the woman walking slowly past a broken handpump, bucket at her side or on her head, on her way to (or from) that scoop or dirty puddle that she once hoped will never again be part of her life.*” (Breslin, 2010).

Break downs in rural water service are frequent in most developing countries. Harvey (2011) estimates that at any one time in sub-Saharan Africa 36% of handpumps are out of service. Studies show that the handpump crisis is imminent with an actual life time of a donor-sponsored standard handpump being 3 - 5 years. A recent study of three districts conducted by Ghana’s Community Water and Sanitation Agency and IRC found 34% of the 474 water points are non-functioning for more than 18 days a year – not meeting the benchmark of providing basic service (Wells, 2015). This functionality of handpumps depends on the ready availability of spare parts and the services of an Area Mechanic. Unfortunately, spare parts are not readily available everywhere and getting the services of an assigned Area Mechanic can be a daunting task. Also, where the spare parts are available, the cost of getting them are often high. As a result, handpumps are regularly out of order and it may take weeks or months before repairs are undertaken. For example, one community in the Shai Osudoku district (in Greater Accra Region) reported a handpump breakdown. No Area Mechanic was available locally and one had to be brought in from ~300km away (Bosomtwi in the Ashanti Region). The time spent on travel alone was six hours. These challenges often lead communities to resort to unsafe sources of drinking water. The situation is far more serious when rural household have to walk several miles to get water from unimproved sources such as rivers and ponds.

Unfortunately the business sector has not yet managed to fulfil the gaps in water services. The typical cost involved in the sale of spare parts alone is high and has stopped most businesses from getting involved. Setting up distribution points close enough to reach all the rural communities that need such service is an expensive undertaking for the private sector. Small profit margins and infrequent purchases from within a distance a customer is willing to travel make it non-profitable to build physical stores. Take for example the most frequently bought spare parts. They are plastic bush bearings, pipe rods, and cylinders for handpumps. These spare parts cost GHS 8, GHS 42, and GHS 320 (~€2, €9, €70) respectively. The profit margin of the highest part is not more than GHS 48 (€11) with approximately GHS 20 (€4.4) of this needed for transportation of the part. This low profit discourages the private sector from going into such business ventures.

Due to the mirage of issues mentioned above, a platform for purchasing spare parts was developed. This technology allows for scaling up the spare parts distribution chain nationally at a very low cost as

## SUSTAINABLE SERVICES

### Private Sector, Public-Private Partnerships (PPPs), Public-Private-NGO Partnerships

compared to the existing business model of setting up stores at locations close to customers. Earning commissions from the sale of spare parts alone is not a lucrative enough venture for most businesses to undertake the upstart cost. The equation changes, however, if donor support is leveraged and the developed platform is able to sell other products.

#### Approach

Following an analysis of the handpump spare parts market, it was concluded that a reliable supply chain coupled with the use of mobile phone technology, would be the best way to provide rural communities easy access to spare parts. The use of mobile phone technology greatly lowers the cost for both users and service providers. Mobile phones erase the need for community members to travel long distances for hours, at a high cost in order to check prices, check availability, order a part, or find a mechanic. Mobile phone technology also allows for rapid scale up since a physical presence is not necessary to conduct business. With these principles in mind, SkyFox, a Ghanaian social enterprise, developed a mobile phone application and e-commerce platform which enables customers to get spare parts delivered to them within 24 hours.

When the technology is deployed in communities, training is given as well as an accompanying user manual. The technology runs on every telecommunication network in Ghana and does not require internet, phone credit, or a smartphone to work. If a user dials \*714\*55# (or \*417# on Tigo) on a phone in Ghana, a menu pops up. Once the menu comes up, the user simply presses the number corresponding to the menu prompts. The system enables communities to report on the functionality of their boreholes, check the cost of handpump spare parts, and order spare parts. If a pump is reported as not working, the system alerts an area mechanic to assess the situation and fix the pump. Handpump functionality data is shared with the government body responsible for Ghana's rural water supply (Community Water and Sanitation Agency) and other stakeholders. If a user wants to order an item, a code for the item is needed. This code comes from the provided ordering manual. Orders for spare parts are paid for in full via mobile money (commonly available in Ghana) before items are dispatched. A combination of existing delivery businesses are used to send the ordered items. By knowing which destinations various delivery companies serve and ensuring drivers know which route our items need to take when there are multiple route options to their final destination, the company is able to ensure orders arrive anywhere in the country within 24 hours.

These technology-based services benefit several groups involved in the water pump repair. Communities benefit from the service because it allows them to check the fair prices of spare parts, avoid any travel or phone calls to contact an area mechanic, and have their pump repaired quickly. Area Mechanics benefit from the service because it gives them a 5% commission on parts they purchase, and items are delivered close to them. Both of those groups benefit because the prices are lower than what is typically available locally. SkyFox benefits by getting a commission on its purchases. The spare parts supplier benefits because their customer base is expanded to farther areas. The Government of Ghana and the water sector benefit because the functionality data collected is fed into the national water monitoring database (District Monitoring and Evaluation System) in order help make more informed decisions and policies.

With this technology platform, the company realized several further business opportunities. In its basic form, the system allows for users to input data and make requests digitally. With these elements, the technology can collect any sort of multiple choice data, take requests for any item or service, or provide brief information. The reliance upon a technology allows for rapid scale up and the coverage of geographic areas as large as distribution channels reach. The company realized that the income from spare part orders alone is not enough to sustain the business in its entirety. Thus expanding into further services is necessary.

The same technology which was aimed specifically at borehole upkeep will be used with for new products being sold. The back-end system for tracking orders of spare parts will soon also track orders for books, hygiene products, and construction materials. The company plans to add further products based upon community feedback and needs. The same payment mechanisms and distribution channels will be used. Lessons learned from sales of the initial item, spare parts, will greatly guide ventures into other items.

## SUSTAINABLE SERVICES

### Private Sector, Public-Private Partnerships (PPPs), Public-Private-NGO Partnerships

The ongoing cost for the technology to function, including servers and telecommunication companies, is approximately 1,300 Euro. The programming was developed with two IT staff members at a cost of approximately 80,000 Euro. The ongoing staffing needs are one accountant, two logistics and support staffers, and one IT programmer each with approximately 20 percent of their time dedicated to the spare parts operation.

#### Origins and Initial Errors

In order to develop the technology needed, the company entered into a public private partnership (SMARTerWASH) with the Dutch government through a joint project with the think-and-do tank IRC and Community Water and Sanitation Agency. Within this partnership, SkyFox was able to finalize development of the system which. Initial stages of development were supported by the Canadian Grand Challenge Fund (won by the college KNUST) and the Triple S project.

Initially the system was based upon SMS technology. This technology gathered input and requests via text messages. This turned out to be problematic due to literacy issues. Thus the system was changed to one that uses USSD technology. This means rather than sending a text message, users see an interactive menu on their screen and only need to select what number corresponds to their desired action.

At the start of the program, the caretakers of the hand pumps were viewed as the target customer. These Water and Sanitation Management Teams (WSMTs) were trained but their orders for spare parts were very few. In the year 2015, the total orders were under 15. The focus on WSMTs was natural as they are seen as the ultimate caretakers of their community borehole(s). WSMTs also are the ones responsible for payment and reporting on the functionality of the borehole(s). Some area mechanics were driving up the cost of repairs by telling the community members that the price was higher than it was. Thus, the company also views the technology as a means to ensure area mechanics are honest on the prices. In time, the company realized that bypassing area mechanics for spare part purchases was fighting against the natural market and also giving a somewhat technical task to the WSMTs. Many of the WSMTs are also illiterate, thus ordering using a system was challenging. Therefore, the target customer was shifted to the Area Mechanics and sales numbers grew to what we see today. The focus on a smaller group of customer (approximately 30 per region) allows the company to call and follow up with each Area Mechanic.

#### Challenges

- Of two main spare part suppliers, one has not partnered with SkyFox. Thus there is heavy reliance upon the dependability of the one partnered supplier. In some cases the part was not available from the partner and had to be purchased at a higher cost from the other supplier. This supplier has not partnered with SkyFox because he believes SkyFox will be a rival in the future.
- Not everyone is able to remember the ordering process.
- Area Mechanics continue to rely upon phone calls to complete orders. Out of the 20 fully successful orders between May 2016 and July, only three were done through the system.
- Communities do not implement pay-as-you-fetch or a monthly tariff, making it difficult to mobilize funds for repairs.
- Some Area Mechanics were not able to follow along with the training program due to inability to operate their mobile phones or because the mobile phones they brought to the trainings were without functional key parts though a secondary phone was owned.

#### Results and Lessons

- The platform has linked up 1,955 communities and 5,059 facilities with the elements needed to monitor or repair a handpump.
- 117 unique phone numbers used the system to report functionality, check a price, or make an order in July 2016.

## SUSTAINABLE SERVICES

### Private Sector, Public-Private Partnerships (PPPs), Public-Private-NGO Partnerships

- Broken handpumps which would have been repaired within a month are now being repaired in an average of 48 hours.
- Initially, Water and Sanitation Management Teams (which are community-based voluntary groups responsible for the management of water facilities) were targeted as the ones to order spare parts. This did not yield the desired results as only GHS 10,000 (~€2,200) sales came from that in 2015. The target customer was switched to Area Mechanics. This change happened recently but it is proving to be a better approach as approximately GHS 135,000 (~€30,000) has been purchased between March and August 2016.
- The system allows for conflict resolution between Area Mechanics and community members because of its transparent nature. Prior to the implementation of the platform, communities thought Area Mechanics were exploiting them because they do not have access to the suppliers or distributors to confirm the prices. With the SMS system, communities as well as Area Mechanics can check and confirm prices.
- Providing training alone for Area Mechanics does not give positive results. Most Area Mechanics after been trained can remember the processes only within a month. Follow-up trainings and phone calls are needed.
- The interest among communities and Area Mechanics to use the platform is overwhelming. Area Mechanics were surprised with what they are able to do with a simple mobile phone. This made them active and participating during conducted trainings.
- Area Mechanics should be considered as major stakeholders in the water sector and treated as such. This is partially because they can deliberately delay communities from getting potable water in the quest to fulfilling their self-interest.

### Conclusions and Recommendations

There is great need to extend business services to rural communities. The service delivery approach used in urban areas typically relies upon physical locations which is cost prohibitive in less densely populated areas. Use of mobile phone technology in combination with a reliable transportation routes allows for rapid delivery to even the most remote of places. The SMS platform has brought smiles to communities and Area Mechanics who until now have travelled long distances to check the price of parts and to make purchases. It has helped reducing time and cost of transport. This has help reduce the downtime of broken facilities. The SkyFox platform is now able to provide orders of numerous products which rural communities have not had easy access to before. The platform, if deployed similarly across other developing countries may drastically reduce down time of handpumps and extend business services to under-served rural communities.

### References

1. Wells, C. da S. (2015, February 9). Reducing handpump downtime using SMS technology: An experiment. Retrieved May 1, 2016, from <http://www.ircwash.org/news/reducing-handpump-downtime-using-sms-technology-experiment>
2. Harvey, Peter (2011) ‘sustainable supply chain for rural water services, linking local procurement of handpumps and spare parts supply’, No 2011-1.
3. Breslin, E. D. Handpump Reliability – a Major Part of the Problem. Retrieved April 29, 2016, from <http://www.simplepump.com/applications/developing-nations/the-problem.html>

SUSTAINABLE SERVICES

Private Sector, Public-Private Partnerships (PPPs), Public-Private-NGO Partnerships

## Pour des MAEP Multi-villages : cas du Niger et expérience de SWISSAID

Type: Article court

**Auteurs :** Idrissa MOUSSA, Chargé de Programme Eau, Hygiène et Assainissement, SWISSAID-Niger, idrissa.moussa@swissaidniger.org - (00227) 20 75 54 30

### Abstract/Résumé

Le Niger dispose d'eaux souterraines de bonne qualité dont la profondeur demande la mobilisation conséquente de moyens techniques et financiers. Malheureusement, les financements accordés au développement du pays dans ce secteur restent insuffisants. Les autorités recommandent ainsi depuis 2011 de réaliser des Mini Adduction d'Eau Potable Multi-Villages (MAEP-MV). Ces systèmes d'approvisionnement en eau consistent en un seul forage et un château d'eau centraux, et d'un réseau de conduites les reliant à des bornes-fontaines dans plusieurs villages. Ils permettent de réduire les coûts de construction en atteignant le maximum de bénéficiaires avec un même forage. En effet dès leur conception, toutes les localités pouvant être desservies à partir de la même source sont recensées. La gestion de l'ouvrage est confiée à un exploitant privé recruté par la mairie. Au niveau local, une Association des Usagers du Service Public de l'Eau (AUSPE), dont les membres sont issus de tous les villages desservis, est mise en place pour assurer la défense des intérêts des consommateurs. Les fonds issus de la vente de l'eau sont logés dans un compte bancaire dont l'utilisation requière la signature de la mairie et de l'AUSPE.

### Introduction

Au Niger, les Mini Adduction d'Eau Potable (MAEP) sont une réponse courante au problème de l'eau. Au vu de leur coût important, l'Etat du Niger a, dans la perspective d'un accès à l'eau pour tous, adopté en 2011 une stratégie de regroupement des villages comme la meilleure option pour booster de façon significative le taux d'accès à l'eau potable. Les MAEP multi-villages consistent en l'installation unique, en un lieu central, d'un captage (forage d'eau), d'un système de pompage (source d'énergie thermique ou solaire), d'une pompe immergée, et d'un réservoir d'eau, permettant d'alimenter tous les villages cibles via un réseau de distribution et plusieurs points de desserte. Ces systèmes connaissent actuellement une évolution significative au Niger.

SWISSAID Niger dont l'accès à l'eau potable est un des objectifs stratégiques, s'est inscrite depuis plusieurs années dans la réalisation de MAEP dans ses zones d'intervention. Elle choisit chaque fois que possible cette approche multi-village en identifiant les villages ayant un problème d'accès à l'eau par zone et en concevant un système pouvant alimenter l'ensemble de ces villages (entre 4 et 11 villages). L'ouvrage est ainsi dimensionné pour pouvoir desservir chacun d'entre eux à travers des bornes-fontaine. Le système inclut aussi l'alimentation en eau des lieux publics (écoles, centre de santé, marchés) ainsi que des abreuvoirs pour le bétail.

De 2005 à 2016, SWISSAID-Niger a réalisé dix MAEP dont cinq (5) sont des MAEP-MV et deux (2) MAEP\_MV supplémentaires démarreront en 2017. Au total, ces ouvrages fourniront de l'eau à plus de 55'000 personnes dans 8 communes. Entre 2400 et 10'000 personnes ont accès à l'eau par MAEP-MV

Tableau 1 : vue d'ensemble des MAEP et MAEP-MV financées par SWISSAID au Niger

Localités	Com-mune	Nombr e de villages	Coût total	Pop desser-vie	Coût main-tenance	Coût/Per s	Etat	Pé-riode
<b>Mini Adduction d'Eau Potable Multi-Villages (MAEP-MV)</b>								
Boullaya	Arzérozi	4	118 000 000	7 384	590 720	15 980	Fonctionnel	2015
Tarabissa	Arzérozi	4	133 000	4 639	371 120	28 670	Fonctionnel	2015

## SUSTAINABLE SERVICES

### Private Sector, Public-Private Partnerships (PPPs), Public-Private-NGO Partnerships

			000					
Haoussaoua	Matankari	11	133 000 000	10 035	802 800	13 254	En cours de réalisation	2016
Bolsi	Torodi	2	55 200 000	2 480	198 400	22 258	En cours de réalisation	2016
Moussa Dey	Falwel	9	143 000 000	6 094	487 520	23 466	En cours de réalisation	2016
Bougou	Dogonkiri	9	146 000 000	6 517	521 360	22 403	En préparation	2017
Kololo	Sanam	3	97 820 000	4 041	323 280	24 207	En préparation	2017
			<b>826 020 000</b>	<b>41 190</b>		<b>20 054</b>		
<b>Mini Adduction d'Eau Potable (MAEP)</b>								
Sakaoua Mous-sa	Dakoro	1	63 778 000	2 120	169 600	30 084	Fonctionnel	2005
Bangaré	Diagourou	1	102 000 000	2 541	203 280	40 142	Fonctionnel	2012
Kobadjé	Torodi	1	80 000 000	4 339	347 120	18 437	En cours de réalisation	2016
Dioga	Torodi	1	74 155 000	4 450	356 000	16 664	En cours de réalisation	2016
Koka	Torodi	1	52 500 000	1 192	95 360	44 044	En cours de réalisation	2016
			<b>372 433 000</b>	<b>14 642</b>		<b>25 436</b>		

Ces villages ont été identifiés sur la base des Plans de Développements Communaux, et des regroupements de villages faits au niveau des communes avec l'appui des services techniques et de consultants indépendants notamment dans le cadre des Plans Locaux Eau et Assainissement (PLEA).

Pour le cas des MAEP, il s'agit généralement de villages d'une taille de plus de 1 500 habitants dont l'accès à l'eau est insuffisant. Pour le cas des MAEP-MV, elles regroupent aussi bien des villages disposants de points d'eau (en quantité ou qualité insuffisante) que ceux qui n'en disposent pas.

Les coûts des systèmes varient d'une part en fonction de leur taille (nombre de villages et personnes à desservir), du contexte hydrogéologique, du type de générateur retenu, et de l'éloignement des localités à desservir. Selon une évaluation des performances de la gestion déléguée du service public de l'eau en milieu rural au Niger réalisée en mars 2016, le coût de la maintenance des MAEP est estimé à 8% des charges totales d'exploitation. Selon cette étude, dans les régions de Dosso et de Tillabéry, les charges d'exploitation représentent 1000 FCFA/an/personne pour 40% des MAEP étudiées.

### Contexte, objectifs et activités

Le Niger est un pays pauvre où le taux d'accès à l'eau potable - estimé à 50% en 2015 selon le rapport des indicateurs du ministère - est une priorité des autorités. Le sous-sol dispose de quantités importantes d'eau pouvant atteindre des profondeurs de plus de 800 mètres en certains endroits, et leur mobilisation nécessite des moyens techniques et financiers assez importants. Plusieurs villages sont donc dépourvus de point d'eau moderne ; les populations de ces localités sont obligées de parcourir des kilomètres pour aller s'approvisionner en eau.

Après l'adoption du Programme National d'alimentation en Eau Potable et d'Assainissement (PNAEPA) en 2011 qui a identifié des villages pour être équipés de MAEP, le Ministère a envoyé une lettre aux directions régionales afin de rattacher d'autres villages à ceux-ci pour constituer des MAEP-MV. Un bureau d'études a même été recruté en 2012 pour appuyer le Ministère dans ce sens.

La réalisation de MAEP-MV a ainsi été retenue par le gouvernement dans ses politiques et stratégies nationales pour un meilleur approvisionnement en eau des populations et pour se rapprocher des Objectifs de Développement Durable (ODD) qui prônent un accès à l'eau potable pour tous d'ici 2030. Selon le rapport annuel du Ministère en charge de l'eau, 15% des systèmes actuels d'approvisionnement

## SUSTAINABLE SERVICES

### Private Sector, Public-Private Partnerships (PPPs), Public-Private-NGO Partnerships

en eau potable sont des MAEP-MV. Ces systèmes sont construits par l'Etat à travers divers programmes et projets, par les ONG internationales et les différentes Coopérations.

SWISSAID finance la réalisation de MAEP-MV avec l'objectif d'offrir un accès à de l'eau de qualité au plus grand nombre de personnes possibles, et d'appuyer le processus de décentralisation et de renforcer les compétences des mairies. Ces ouvrages sont construits par des entreprises agréées recrutées par appel d'offres ouvert selon les procédures nationales. Pour leur gestion également, les délégataires sont recrutés par appel d'offres ouvert selon les procédures du Guide.

Ces prestataires sont recrutés par les mairies avec un appui de SWISSAID.

En effet, dans le cadre de la décentralisation, le Gouvernement du Niger a adopté un décret de transfert de compétences aux communes, leur conférant notamment la gestion de ces systèmes d'approvisionnement en eau (maîtrise d'ouvrage communale). Celles-ci ont cependant besoin d'être renforcées et accompagnées afin d'assurer convenablement ce rôle.

Ainsi, SWISSAID, en plus du financement des ouvrages, forme les responsables communaux dans l'organisation du service public de l'eau, met à leur disposition les documents stratégiques de ce secteur, et les forme au processus de passation de marché. SWISSAID appuie la désignation d'un point focal eau et assainissement ou la création d'un Service Municipal Eau et Assainissement qui bénéficie également de la formation sur l'organisation du service public de l'eau, et apporte un appui financier pour le suivi des activités en lien à l'eau et l'assainissement. Ainsi chaque commune arrive à créer et gérer un fonds commun pour le renouvellement et l'extension des MAEP avec une comptabilité analytique au niveau de chaque MAEP pour vérifier sa rentabilité. Les Services Techniques interviennent également dans l'organisation du service public de l'eau, en assurant le contrôle et la régulation et un Service d'Appui Conseil qui assiste la mairie techniquement dans la gestion du service public de l'eau.

Pour la réalisation des MAEP-MV plusieurs étapes sont nécessaires :

Divers **études** sont d'abord conduites : une étude hydrogéologique et géophysique afin de s'assurer de la disponibilité de l'eau et d'estimer la profondeur et le débit du forage ; une étude technique pour confirmer la faisabilité de l'ouvrage ; et une étude socio-économique pour déterminer l'acceptabilité du système par les populations. Il arrive en effet que les communautés présentent des différences sociales entravant une collaboration entre elles, ou que la présence de sources d'eau alternatives gratuites constituent une trop forte concurrence au système.

Le **recrutement de l'entreprise** qui réalisera l'ouvrage se fait par appel d'offres. La décentralisation étant instaurée de manière effective au Niger, la commune est responsable des passations de marché. Cependant, ce rôle demande beaucoup d'assistance et de renforcement de capacités pour qu'elle l'assure convenablement. De plus, ce processus peut prendre du temps surtout s'il s'avère infructueux, nécessitant de relancer l'appel d'offre.

Le Niger a élaboré et adopté en 2010 un Guide pour la gestion du service public de l'eau<sup>1</sup>, qui recommande la **mise en gestion déléguée** des MAEP. Ainsi un délégataire privé est recruté par la mairie, également par appel d'offres, pour la gestion de l'ouvrage.

**Une Association des Usagers** du Service Public de l'Eau (AUSPE) est créée afin d'assurer la défense des intérêts des usagers. Celle-ci rendra compte à la mairie du bon fonctionnement de l'ouvrage et veillera que le délégataire recruté par la mairie respecte le contrat de gestion signé avec la mairie et que, dans toutes les localités, les populations utilisent les ouvrages conformément au règlement d'usage. L'association est composée d'hommes et de femmes issus des différents villages. Sa mise en place requière beaucoup d'attention, et il faut prendre le soin d'expliquer qu'il ne s'agit pas d'une compétition entre villages, mais plutôt de s'associer en vue de défendre leurs intérêts communs. Aussi, l'attention de la population est attirée sur le fait que ce sont les études techniques et socio-économiques préalables qui déterminent le lieu d'implantation des ouvrages, dans le but d'atteindre le maximum de population.

Les **recettes** issues de la vente de l'eau sont réparties en Part Déléguataire et Part Maître d'Ouvrage, cette dernière servant à la mairie à assurer le fonctionnement, le renouvellement et l'extension de l'ouvrage.

### Résultats principaux et leçons tirées

Les MAEP-MV ont donné des résultats satisfaisants, car **ces ouvrages sont fiables et sont gérés de façon durable** à travers les dispositions du guide national du service public de l'eau. Selon le rapport annuel des indicateurs du Ministère en charge de l'eau<sup>2</sup>, au Niger le taux de panne de ces systèmes est

## SUSTAINABLE SERVICES

### Private Sector, Public-Private Partnerships (PPPs), Public-Private-NGO Partnerships

estimé en 2015 à 3.16%, ce qui est très faible par rapport aux autres types d'ouvrages d'approvisionnement en eau potable. Dans le cas des 4 ouvrages financés par SWISSAID, tous sont toujours en service. Ils garantissent aussi un accès facile à de l'eau de proximité et préserve la qualité de l'eau desservie. La qualité de l'eau est testée à la réalisation des ouvrages et le contrat de gestion exige du délégataire un test tous les six mois. La maintenance est assurée par le délégataire à partir de la part qu'il touche des recettes de la vente de l'eau. Le renouvellement des équipements est du ressort de la commune, sa part lui permettant de mettre en place des fonds de roulement et d'extension. L'accès est équitable pour tous les usagers : l'eau est payante aux points de distribution selon une redevance fixée au mètre cube d'eau vendu au compteur, et exprimée d'après les types de récipients couramment utilisés par les populations. Le prix est à la portée de tous. De plus, ces ouvrages contribuent à l'équité hommes femmes, puisque les nouveaux robinets sont utilisés aussi bien par les hommes que par les femmes. Les hommes s'investissent dans la corvée d'eau domestique par le transport des bidons d'eau sur leurs charrettes.

En effet avec ces types d'ouvrages, l'accès à l'eau est facilité pour tous les villages bénéficiaires, du fait de l'implantation de bornes fontaines et de robinets à proximité des ménages de chaque village desservi.

Les MAEP-MV permettent d'atteindre un maximum de personnes dans une zone considérée, en **diminuant beaucoup le coût par bénéficiaires**. En effet, une MAEP-MV a les mêmes résultats du point de vue de l'accès à l'eau que la construction d'une MAEP dans chaque localité connectée, tout en supprimant les coûts qu'aurait engendré la réalisation du captage, de la source d'énergie et du réservoir dans chacune des localités. Les coûts de ces équipements peuvent représenter plus de 60% du coût de réalisation. Une MAEP y compris le forage coûte en moyenne 75 000 000 FCFA alors qu'une MAEP-MV peut coûter en moyenne 120 000 000 FCFA. Réaliser une MAEP-MV pour trois localités, par exemple, revient ainsi à économiser plus du tiers de l'investissement total. Il suffit juste de réaliser au préalable les études techniques et socio-économiques nécessaires pour s'assurer de la faisabilité technique (distance entre les villages, topographie, taille des villages, ...). Les MAEP-MV peuvent fournir de l'eau à des villages se trouvant à plus de 20 kilomètres l'un de l'autre. Il peut s'agir de villages et de leurs hameaux rattachés ou d'agglomérations totalement indépendantes entre elles.

Ces systèmes d'approvisionnement en eau sont de plus **extensibles** : conformément aux procédures définies dans le guide national à travers la mise en place de fonds de renouvellement et d'extension avec la vente de l'eau, une réserve est calculée lors du dimensionnement des ouvrages, sur la base d'une projection de la croissance de la population sur les 10 ans à venir, afin de pouvoir étendre plus tard le réseau vers de nouveaux quartiers et/ou ménages.

Ainsi, les MAEP construites par SWISSAID ont fait l'objet d'une extension pour alimenter de nouveaux quartiers sous financement des Mairies à travers les Fonds de Renouvellement et d'Extension (FRE).

Du point de vue social, ces ouvrages permettent de **nouer une solidarité** entre les différentes localités desservies, du fait qu'elles acceptent de partager la même source d'approvisionnement en eau potable et que l'ouvrage central soit implanté dans le lieu permettant d'atteindre le maximum de personnes. Cela crée une volonté de travailler ensemble et de coopérer pour l'amélioration de leurs conditions de vie, qui pourra les conduire à relever ensemble d'autres défis communs. Une MAEP-MV peut couvrir des villages appartenant à plusieurs communes et favoriser ainsi l'intercommunalité. Les MAEP-MV ont amené des populations qui avaient des querelles entre elles à s'accepter et à s'associer pour collaborer. A Boullaya par exemple, la MAEP-MV a mis fin aux querelles qui existaient autour des puits traditionnels entre les éleveurs et les populations autochtones.

Ces systèmes **créent des emplois au niveau local et génèrent des recettes** permettant d'assurer leur fonctionnement, leur extension et leur renouvellement.

Certains **défis** existent néanmoins, notamment en lien au manque de moyens des communes et des services techniques de l'Etat, de la faible expérience de certains délégataires ou de la réticence des populations à accepter la gestion déléguée.

Dans la gestion des contrats, à cause d'une insuffisance des ressources humaines, le point focal eau au niveau de la commune est désigné parmi le personnel de la mairie, augmentant ainsi son cahier des



## SUSTAINABLE SERVICES

### Private Sector, Public-Private Partnerships (PPPs), Public-Private-NGO Partnerships

charges. Les mairies ne disposent souvent pas des compétences humaines pour relancer un appel d'offres pour le recrutement d'un nouveau délégataire après la fin ou la résiliation d'un contrat, ce qui peut entraîner un retour à la gestion communautaire. Les services d'appui conseil (SAC) n'existent pas encore dans toutes les communes ou ne sont qu'à leur début et les services déconcentrés de l'Hydraulique ne disposent pas de moyens humains et matériels suffisants, ni pour apporter leur appui ni pour suivre les activités du Service Public de l'Eau (SPE).

Les outils de gestion mis en place dans le guide ne sont souvent pas utilisés efficacement par les acteurs.

Au démarrage du contrat de gestion, des fonds de garanties doivent être fournis par le délégataire afin de subvenir à d'éventuelles défaillances de celui-ci, mais ces fonds ne sont pas toujours mobilisés.

Le dysfonctionnement des installations entraîne une mésentente entre la mairie et le délégataire quant à la responsabilité de remettre en état.

Certains responsables des bornes-fontaines démissionnent par manque de recettes suffisantes du fait des pertes ou bien d'éventuelles fuites sur les bornes fontaines, ce qui entraîne souvent la fermeture des points de desserte.

Les redevances communales et l'état des Fonds de Renouvellement et d'Extension dûes et collectées sont pas suffisamment transparents.

De ces premières expériences, SWISSAID Niger a appris que la réalisation de ces types d'ouvrages constitue la meilleure approche pour améliorer l'accès à l'eau potable de façon durable.

La réalisation de ces ouvrages suscite de l'intérêt de la part de toutes les localités dans une zone considérée. Cependant la satisfaction des demandes dépend des résultats des études de faisabilité. Il faudra donc tenir compte de cet aspect afin d'éviter de créer des mécontents autour de l'intervention.

En plus des regroupements déjà envisagés, il faut aussi inclure tous les villages pouvant être alimentés par la future MAEP-MV.

Une réunion d'éclaircissement doit être organisée avant la mise en service des ouvrages, elle doit regrouper toutes les parties prenantes dans la réalisation du projet et les acteurs du SPE. Elle permettra de situer les responsabilités de chacun dans la mise en service des installations durant la période de garantie des ouvrages, en effet les ouvrages réalisés sont sous garantie d'un an conformément aux réglementations nationales.

De plus, un accent particulier doit être porté sur le renforcement des capacités de l'AUSPE. En effet dans la stratégie nationale, l'AUSPE ne gère pas de recettes, mais peut disposer d'une subvention dans les recettes issues de la vente de l'eau de la part de la mairie pour mener des actions à travers un plan d'action approuvé. Cependant l'élaboration de ce plan d'actions est rarement garanti, ce qui limite la participation effective de cet acteur dans le suivi de la gestion des MAEP-MV.

### Conclusions et Recommandations

Dans les zones rurales où l'eau est présente en quantité, les MAEP-MV constituent des solutions efficaces et plus efficaces pour l'alimentation en eau pour tous. En plus de faire collaborer plusieurs localités, elles permettent de couvrir les besoins en eau de toutes les composantes de la société. C'est aussi une opportunité de réunir des personnes provenant de divers horizons pour travailler ensemble en vue de garantir la durabilité du service public de l'eau.

SWISSAID trouve la réalisation de MAEP-MV pertinente et conseille fortement la réalisation de ce genre d'ouvrages afin d'améliorer un accès équitable à l'eau pour tous. Sur la base des expériences réalisées jusqu'à aujourd'hui, les éléments suivants ressortent comme des facteurs importants de succès :

Pour que ces ouvrages fonctionnent de façon durable, il faut impérativement confier leur gestion à un délégataire disposant des capacités techniques (moyens personnel et matériels) nécessaires pour assurer la continuité du service public de l'eau. Il faut exiger de tous les opérateurs privés contractualisés par les mairies la mobilisation de personnel compétent et expérimenté.

Les contrats doivent être établis avant la réalisation des ouvrages pour que le personnel du délégataire puisse être initié par l'entreprise ayant réalisé les travaux .

Il est nécessaire d'être attentif au moment de la conception de l'ouvrage et de se baser sur des données objectives telles que les résultats des études, car chacun souhaite avoir l'ouvrage central dans sa localité.

## SUSTAINABLE SERVICES

### Private Sector, Public-Private Partnerships (PPPs), Public-Private-NGO Partnerships

Pour les participations financières de la population, il faut s'assurer qu'elles se fassent de manière participative. De plus, il est important d'enquêter sur l'existence d'éventuels conflits et de les prendre en compte dans la mise en oeuvre. Les études et tests sont indispensables pour s'assurer de la disponibilité en quantité et en qualité de la ressource en eau (existence d'un forage à fort débit ou potentiel pour un tel forage). La création d'un Service Municipal Eau et Assainissement (SMEA) doit être exigée, ou à défaut un point focal Eau et Assainissement qui va superviser les travaux de construction et les contrats de délégation de gestion du service public de l'eau. Des ouvrages inter-communaux peuvent être envisagés pour augmenter le volume d'eau distribué et les moyens humains disponibles. Les montants annuels des parts Fonds de Renouvellement et d'Extension (FRE) et "Redevance communale" sur le m<sup>3</sup> d'eau vendu doivent être inscrits dans le budget communal (en budget annexe) pour qu'ils puissent faire l'objet d'une plus large diffusion (au Conseil communal) et d'un audit périodique.

### Mentions

Les ouvrages à Torodi et Matankari sont réalisés dans le cadre du Consortium Suisse pour l'Eau et l'Assainissement (constitué de huit ONG Suisses), implémentant des projets eau dans plusieurs pays, financés à 75% par la DDC (Coopération Suisse).

### Références

<sup>1</sup> Direction generale de l'hydraulique (2010) 'Guide des services d'alimentation en eau potable dans le domaine de l'hydraulique rurale', document du gouvernement nigérien

<sup>2</sup> Ministère de l'hydraulique et de l'assainissement (2016) 'Rapport sur les indicateurs de l'eau potable et l'assainissement pour l'année 2015', document du gouvernement nigérien

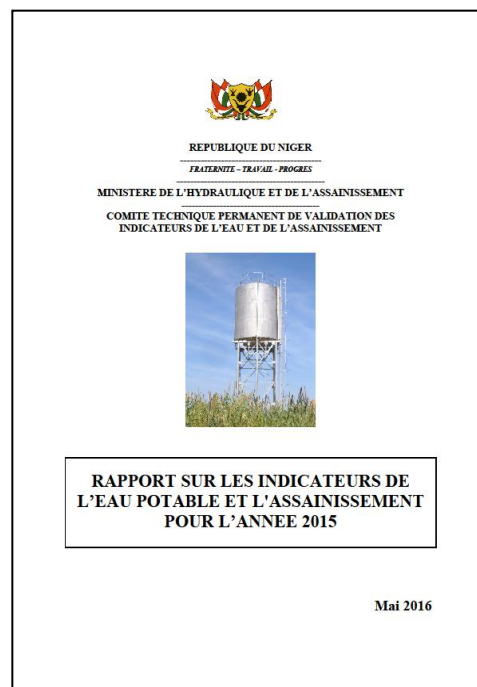
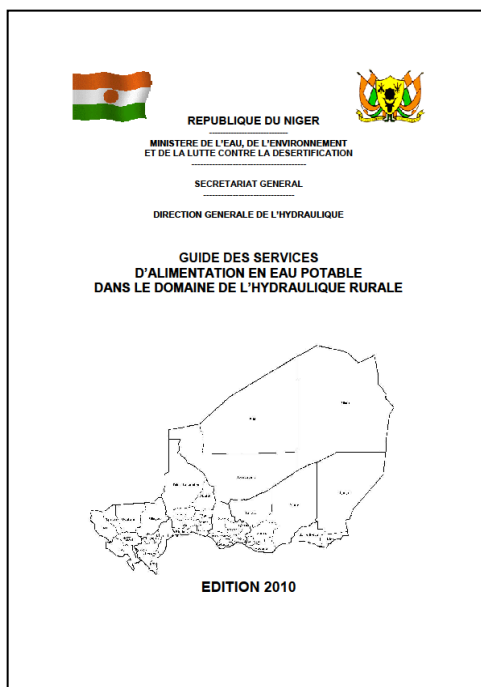

## SUSTAINABLE SERVICES

Private Sector, Public-Private Partnerships (PPPs), Public-Private-NGO Partnerships

---

# Can PPCPs Improve Water Services Delivery in Rural Areas? Insights from Kenya

---

Type: Long Paper

**Authors:** Chiranjibi Tiwari, WASH Sector Leader  
**Address:** SNV Netherlands Development Organisation Kenya  
Ngong Lane, Off Ngong Road  
P. O. Box 30776, 00100 Nairobi, Kenya  
**Tel:** +254 733608034

**Email:** [ctiwari@snvworld.org](mailto:ctiwari@snvworld.org); [chiranjibi.tiwari@gmail.com](mailto:chiranjibi.tiwari@gmail.com)  
**www:** <http://www.snvworld.org/>  
**LinkedIn:** <http://ke.linkedin.com/pub/chiranjibi-tiwari/18/35b/a7b>

### Abstract/Summary

In Kenya, less than twenty-five percent of population is served by formalised water services providers (WSPs). Water services to remaining 75% of population (in rural and peri-urban areas) is managed by voluntary water users associations. Frequent breakdowns caused by various reasons, including lack of resources to pay power bill, lack of spare parts and technicians for operation and maintenance among others has been a key barrier to sustainable water services delivery in these areas. To address this challenge, public private community partnership (PPCP) models were designed and introduced. From 2012 to 2015, two regional water services boards have engaged five Private Operators (POs), resulting in improved outreach, reliability, quality and sustainability of water services delivery, benefitting 72,791 people. Improvements made by these POs in service expansion, supply hours, timely repair of leakages and bursts, and community satisfaction indicates that PPCPs can improve water services delivery in rural areas.

### Introduction

This paper describes the context, approach, results and emerging lessons of the Public Private Community Partnership (PPCP) programme implemented by SNV in Kenya. The paper argues that PPCPs can offer solutions to sustainable water services delivery, benefitting millions of un-served and under-served people in rural and peri-urban areas in the world.

Kenya has recorded impressive GDP growth of more than 5% over the last decade (World Bank, 2014). However, less than 10.5 million people (approximately 25% of total population) is served by the 91 public water and sewerage companies (commonly known as WSPs) registered with the national regulator in 2014 (WASREB, 2015). Remaining, about 75% of the total population, mostly living in rural and peri-urban areas, fetched their drinking water from wells, rivers, streams, ponds, and sand dams. The majority of such water sources are managed by voluntary water users associations (WUAs) or informal suppliers and have problems related to frequent breakdowns, reliability/continuity, quality and adequacy. As these WUAs lack effective management practices, almost 1/3<sup>rd</sup> of these systems are mal-functional at any given time (SNV, 2013) and limited resources available with NGOs and local governments (public authorities) are depleted in repair and rehabilitation of these mal-functional water systems, making none or minimal resources available to expand services to un-served rural and peri-urban areas, mostly inhabited by the poorest quintiles. Therefore, lack of effective models for management of water sources/projects has been a key barrier to expand services to rural and peri-urban areas in this context. The Kenyan situation represents the wider context in the developing world, where only 68% of rural water projects are

## SUSTAINABLE SERVICES

### Private Sector, Public-Private Partnerships (PPPs), Public-Private-NGO Partnerships

functional at any given time (Akvo, undated), indicating failure of billions of dollars invested in rural and peri-urban areas.

The Water Act of 2002 is the main legal framework for water services delivery in Kenya. WASREB has the mandate of regulating the entire water sector, but has managed to regulate less than 100 public WSPs, with a service area of about 50% of total population (WASREB, op.cit.). As per the Act, day to day management of water services is delegated to public WSPs. These WSPs sign a service provision agreement (SPA) with the Water Services Boards (WSBs) and assume monopoly role for water services delivery within the service area designated by the SPA. These WSPs are expected to run like businesses, however, had efficiency challenges as they are heavily influenced by public bureaucratic mind-set, without enough incentives to growth. Most consumers residing in areas served by public WSPs get water through piped connections. However, in rural and peri-urban areas, voluntary WUAs are managing community water projects and most consumers commute for hours to fetch their drinking water.

Public Private Partnership (PPP) Act of 2013 and PPP Policy of 2012 have created space for private sector engagement and PPPs in water sector. County Governments (CGs) are newly established by the Constitution of Kenya 2010, and are developing their capacity in all aspects; most of them lack a clear strategy for water sector. There is a robust market for many of the supporting functions such as information and communication technology, auditing, media, repairs and maintenance services among others. However, the market is skewed in favour of the large public WSPs. Access to finance is partially developed with various forms of result based financing mechanism (e.g. Global Partnerships for Output Based Aid, Aid on Delivery etc.) designed to support credit-worthy public WSPs. As the rural and informal WUAs do not enjoy healthy cash flow, they cannot access market finance.

In line with the global quest for sustainable water services delivery models in rural and peri-urban areas, SNV Netherlands Development Organisation in Kenya supported two WSBs, Lake Victoria North and Lake Victoria South, collectively responsible for provision of water services to 15.8 million people (36% of Kenyan population) in design and introduction of innovative models of water services delivery, engaging private Operators, local government authorities and communities, in the form of Public Private Community Partnership (PPCP). During the first four years (2012-2015) phase of the project, four types of PPCPs were introduced, engaging private firms as Water Operators (POs). This has resulted in improved outreach, reliability, quality and sustainability of water services delivery, benefitting more than 72,791 people. The PPCP approach primarily builds on the domestic private sector participation approach described by Delmon, Victory R. (2014), and brings in ‘partnerships’ perspective to ensure win-win for all parties.

### Description of the Case Study – Approach or technology

#### Making Markets Work for the Poor (M4P)

As the focus was on introducing commercially viable management models, SNV adopted M4P approach (The Springfield Centre, 2014), which is used primarily in economic development sectors. The approach considers poor people as a part of the market system and argues that they can improve their livelihoods when such market systems are aligned to their contexts and capabilities. The approach further argues that effectiveness of the CORE business within a given sector is shaped by the RULES governing the sector and associated SUPPORTING FUNCTIONS.

The methodology used by SNV in introducing the commercial management models of rural water services delivery in Kenya involved the following steps:

- **Sector analysis using the M4P framework** (refer to figure 1): This involved the analysis of

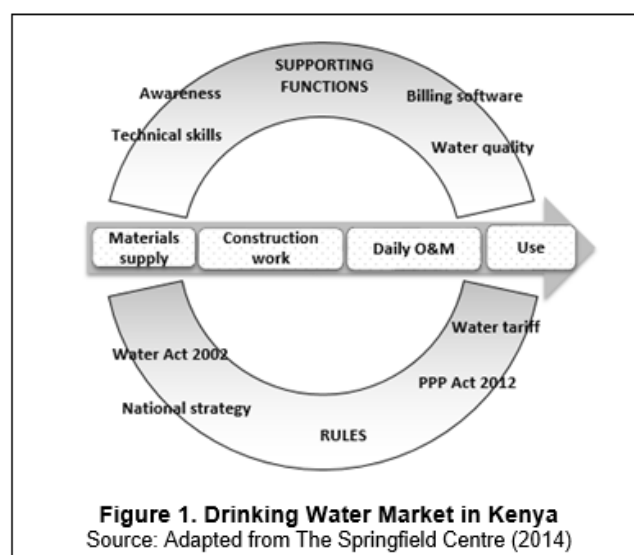

**Figure 1. Drinking Water Market in Kenya**  
Source: Adapted from The Springfield Centre (2014)

## SUSTAINABLE SERVICES

### Private Sector, Public-Private Partnerships (PPPs), Public-Private-NGO Partnerships

the core functions in the water sector (demonstrated by the four boxes along the central arrow), relevant supporting functions (demonstrated by the upper arch) and associated rules, regulatory and legal frameworks (demonstrated by the lower arch). The core functions relate to the production and treatment of water, day to day management of water infrastructures and managing sales and consumer relations. Private construction companies contracted by the public Water Services Boards (WSBs) carry out water production (e.g. dam construction, pipeline work, treatment plants, sinking of boreholes, etc.) functions. These companies buy their materials and inputs (e.g. cement, pumps, pipes, fittings, meters, solar equipment, chemicals etc.) from a vibrant manufacturing sector. Daily operations and management (O&M) of water services is managed by public WSPs and WUAs, as explained above.

- **Household survey to understand the social and economic context of the project area:** A household survey was carried out with the water consumers from the project area, using a systematic random sampling method. A sample size of twenty households covered by each water project was used for the research. Statistical Package for Social Sciences was used to analyse the quantitative data, which was later triangulated with the qualitative information collected through observation and group discussions with WUAs and consumers.
- **Participatory design of management models and programme interventions:** A participatory workshop setting was used to reflect on the household survey findings, consumer preferences and affordability of alternative commercial management models. In addition, stakeholder consultation workshops at local (district), regional and national level were organised to agree on the roadmap, potential management models and the key interventions required to introduce and scale up such models. Based on the feedbacks received, range of PPCP models were developed. Key interventions implemented include: i) policy advocacy and advice for water legislation and PPCP models, ii) strengthening public sector capacity on design and implementation of PPCPs, iii) business strategy support to POs and WUAs and, iv) consumer awareness raising on the importance of clean drinking water. As PPCP and engagement of POs was a relatively new concept in the Kenyan water sector, a strong advocacy and technical assistance throughout the process was needed. Furthermore, contracted POs did not have prior experience as water operators and had to be trained and mentored on the social aspects of engaging with and managing community dynamics. Users also required intensive awareness to help them understand how their cooperation could impact on sustainable water services.
- **Monitoring of the performance and impacts:** The results were assessed using: i) performance monitoring of the PPCPs using a monthly tracking tool, and ii) sample household impact assessment, using descriptive statistics and regression analysis.

### Main results: outcomes and impacts

During the four years (2012 – 2015), SNV has achieved a number of milestones towards scaling up sustainable management models. The key outcomes (results at the water project management and institutional level) and impacts (beneficiary level results) are outlined below.

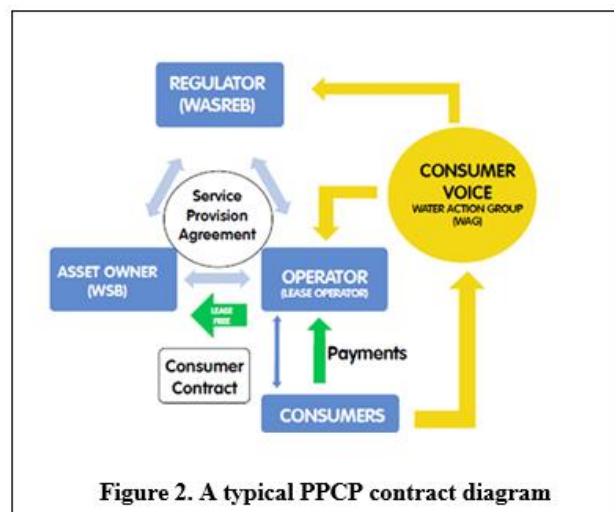

Figure 2. A typical PPCP contract diagram

### Outcome 1. PPCP models designed and introduced by two WSBs

The key finding of the sector analysis and consumer research indicated that more than 74% of the respondents had experienced frequent interruptions in water supply due to pipe bursts and that they were willing and able to afford commercial water tariff if quality, reliability, affordability and convenience were guaranteed (Iwari, 2013). The participatory workshops concluded that poor people in rural areas could benefit by engaging professional management firms as Water Operators. It was also suggested that various forms of PPCPs would be the desired model for water services management in the context. SNV catalysed the two WSBs in developing a range of PPCP models in a participatory way and in engaging POs through a transparent and competitive procurement process. A typical contractual model developed by the two WSBs is illustrated in figure 2, where Public Sector (Asset Owner WSB), PO (Operator) and Community (Water Action Group) are the three parties that sign a mutually beneficial agreement. The key outputs achieved by the programme are cited below:

## SUSTAINABLE SERVICES

### Private Sector, Public-Private Partnerships (PPPs), Public-Private-NGO Partnerships

- Three management consulting firms are engaged as POs: Romada Pvt. Ltd, Breinscope Consulting Ltd and Lobonyo and Associates are managing Elgon East, Kanyadhiang and Wandiege rural water projects respectively.
- An Urban WSP, Kakamega Busia Water and Sewerage Company has expanded water services to Navakholo village in Kakamega County.
- A community group (WUA) in Tachasis village of Nandi County has transformed itself into a commercial and legal WSP.

In addition, improved cooperation among the parties and improved enabling environment for the PPCPs are the key outcomes achieved by the programme, which are further explained below:

#### Outcome 2. Improved co-operative behaviour among the public sector, POs and communities

- All key stakeholders have demonstrated improved confidence, transparency and accountability on the way water projects are managed leading to improved cooperation among WUAs, WSBs, CGs and POs.
- POs are responding to consumer issues/complaints promptly, and are replacing incompetent staff; some POs have incentivised staff performance by awarding bonuses (e.g Tachasis Ltd). By doing this, POs have demonstrated that they can indeed improve sustainable services to their consumers.
- POs prompt response to repairing leaks and bursts has contributed to improved customer satisfaction and increased service hours.

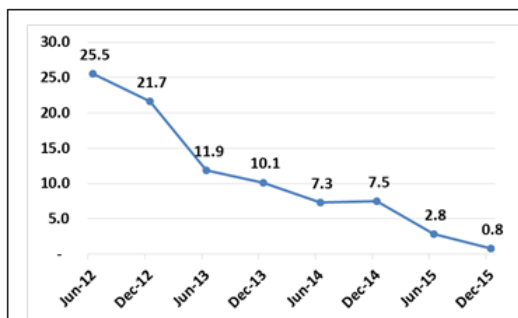

Figure 2. Monthly frequency of breakdown

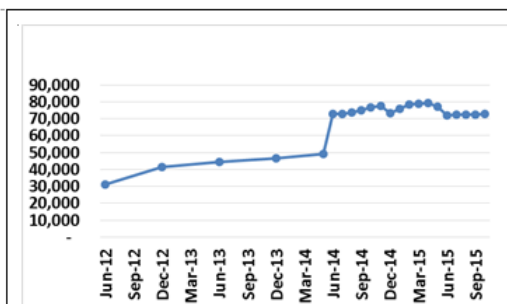

Figure 3. Population served by 5 projects

#### Outcome 3. Improved enabling environment for POs

- Increased knowledge and confidence of public sector and WUAs has created more conducive environment for POs engagement.
- Ten County Governments (CGs) have developed their water sector strategy, recognising the role of private sector in addressing water services delivery challenges.
- The National Ministry of Water and Irrigation has developed PPP Guidelines for the water sector.
- More development partners (e.g. EU, UNICEF, and USAID) have recognised the PPCP model in their strategies, indicating a huge potential for scaling up the same.
- National regulator WASREB (2015) has recognised the PPCPs by publishing a case study in their annual IMPACT report of 2015.

#### Impact 1: Improved services to under-served and un-served consumers

Several changes are achieved at the beneficiaries’ level, including but not limited to: i) reduced frequency of water project breakdown (Ref. Figure 2) leading to increased supply hours for the consumers; ii) increased number of men and women (72,791 consumers, in December 2015) are benefitting from re-connections and new connections (Ref. Figure 3). These changes are accompanied by continuous improvement on revenue base (Ref. Figure 4) of the POs, indicating that the changes are likely to be sustained by the POs.

#### Impact 2: Increased income/savings of consumers

Sample impact study (SNV, 2015) demonstrated that improved access to water services has directly contributed to improved economy at the household level as indicated by the following results:

- Each household saved an additional KSh 5,116 (USD 51) per month productively using the time saved in water collection.

## SUSTAINABLE SERVICES

### Private Sector, Public-Private Partnerships (PPPs), Public-Private-NGO Partnerships

- Some households (at least 15) have started new micro-enterprises such as hotel/restaurant businesses, kitchen gardening, etc. and consequently increased their incomes by about KSh 5,000 (USD 50) per month.

Satisfied consumers, co-operative behaviour among Operators, WUAs and public authorities and increased revenue base of the POs indicates that the PPCPs have indeed contributed to address sustainability challenges of water services to the poor in the project areas. Increased consumer confidence/satisfaction and increased revenue base of POs challenges the common argument that poor people cannot pay for commercial water tariff, and that private sector has no business incentives in the water sector.

### Challenges, Lessons and Recommendations

Engagement of private firms as Water Operators is feasible and, this can improve sustainability of water services delivery by addressing several issues such as cost recovery, repair, maintenance, and service expansion. POs can achieve economy of scale by gradually expanding outreach as demonstrated by the five PPCPs implemented in Kenya. However, entire process of identifying and engaging POs is very demanding; several challenges emerge and need to be mitigated. Some of the challenges emerged and lessons learned are highlighted below:

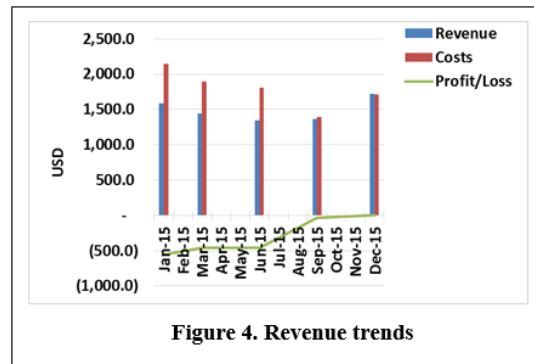

Figure 4. Revenue trends

### Getting buying in of the local governments and WUAs

Despite huge demand for improved services, WUAs had fears that POs would increase water fees and *steal* their revenues. In addition, communities in Elgeyo-Marakwet and Kisii County were less receptive of the idea of engaging POs from outside; they were comfortable only with Operators from within their own ethnic groups, delaying the entire process. This was managed through facilitation of conflict mediation, awareness raising of consumers and WUAs, peer-reviews and peer-learning sessions. Similarly, the bid winning POs required to make commitment that they would recruit local staff as and when feasible. To get buying in of the County Governments, the programme had to facilitate the CGs to develop their water sector strategy, creating space for POs engagement. The good outcome, most Counties are now ready to take the approach to scale. The key lessons from this process is that the POs engagement process needs to be inclusive so that all key stakeholders, consumers, POs and regulators of the service (WSBs or CGs) have full confidence and commitment to support such models. In rural areas, where the WUAs are operating on voluntary basis, there is a need for targeted education and awareness to consumers.

### Access to finance for hardware’s is crucial

All the five project’s business plans indicated that the projects would require some investments on rehabilitation, pipeline extension and household connections etc. to make them viable for the POs. Expectation was that WSBs and CGs would be able to mobilise public finance for these activities as per the government policy. However, mobilising public funds was practically difficult, which delayed the full-fledge implementation of the contracts. SNV and its partner Kenya Market Trust structured *a blended finance facility* in the form of an *Output Based Grant* (OBG) to mitigate this risk. The key lesson we learned from the five projects is that provision for hardware rehabilitation, pipeline extension and metering investments are key to successfully engaging POs.

### Private sector is not the silver bullet, they also need capacity support

As the POs were not recognised as water operators in Kenya in the past, it was very difficult to find experienced POs to come on board. As the winning POs had no prior experience as water operators, SNV had to strengthen their capacity through business development training, advice and mentoring support. It was evident that the reforms took longer period than originally envisaged, indicating that the market reforms in social development sectors such as drinking water supply in rural areas require more efforts and time compared to economic development sectors.

In conclusion, education and awareness of consumers, capacity strengthening of POs, support to public authorities and availability of smart grants are pre-requisites to have successful outcomes through PPCPs in management of water services in rural and peri-urban areas. Stakeholders need to go beyond *business as usual* and the *one-size-fits-all* approach.

### References

## SUSTAINABLE SERVICES

### Private Sector, Public-Private Partnerships (PPPs), Public-Private-NGO Partnerships

- Akvo (undated). Available at: <http://www.dutchwatersector.com/news-events/news/13896-wwf7-akvo-flow-hits-one-million-mark-for-field-surveys.html>. [Accessed on 19 April 2016]
- Delmon, Victory R. (2014). *Structuring private sector participation contracts for small scale water projects*. The World Bank and IFC.
- KNBS (2010), *Kenya National Bureau of Statistics*. Available at: [http://www.knbs.or.ke/index.php?option=com\\_phocadownload&view=category&id=109:population-and-housing-census-2009&Itemid=599](http://www.knbs.or.ke/index.php?option=com_phocadownload&view=category&id=109:population-and-housing-census-2009&Itemid=599). [Accessed on 13 Oct 2015].
- SNV (2013), *Water Point Mapping Report*. SNV Kenya. Unpublished.
- SNV (2015), *Impact of Private Operator Involvement in Water Service Delivery Among Seven Projects in Kenya*, SNV Kenya. Unpublished.
- Tiwari, C. (2013), ‘Water services delivery as a business: an approach to sustaining water services in rural areas’. In: *36<sup>th</sup> WEDC International Conference, Delivering Water, Sanitation and Hygiene in an Uncertain Environment*. Nakuru, Kenya.
- The Springfield Centre (2014), *The Operational Guide for the Making Markets Work for the Poor (M4P) Approach*, 2<sup>nd</sup> edition, funded by SDC & DFID.
- WASREB (2015), *A Performance Report of Kenya’s Water Services Sector – 2014/2014, Issue 8*, Water Services Regulatory Board, Kenya.
- World Bank (2014). *Kenya economic update: anchoring high growth - can manufacturing contribute more?* Kenya economic update; Edition no. 11. Washington DC; World Bank Group.



## SUSTAINABLE SERVICES

### Community Managed Supplies

#### 3.3.6 Community Managed Supplies

---

## Towards Achieving A Sustainable Community-led Rural Water Supply Management Model in Zambia: Strides or Rhetoric?

---

**Type:** Long Paper (up to 6,000 words)

**Authors:** *Sankwe Michael Kambole, Riverine Development Associates, P.O. Box 451, Zambia; Email: [mksankwe@gmail.com](mailto:mksankwe@gmail.com), Telephone: (Work) +260211256818, Cell: +260977850153*

### Abstract/Summary

Over 60 percent of the Zambian population live in rural areas with poor access to basic services, including improved water sources. In 2005 access to improved water sources for the rural population was estimated at 37 percent (GRZ, 2015) and this increased to 41.9 percent and 51.4 percent in 2006 and 2010, respectively (UNDP, 2013). The driver was the sector-wide reforms initiated in the mid-1990s. Despite this increase, maintenance of hand pumps remained a huge challenge leading to several hand pumps being abandoned on account of not working. The other reason that led to hand pumps being abandoned was the poor quality of water due to iron-rich groundwater. Overall, community-led management models seemed to have failed; grassroots management structures were not functioning; area pump menders acted with impunity; adequate regulatory mechanisms to control area pump menders were absent. Worse still, ineffective reporting structures overwhelmed these models. In Central and Luapula/Northern provinces, for example, boreholes were abandoned in 56.4 and 55.8 percent of communities investigated, respectively, mainly because maintenance was absent.

### Key words

*Iron-Rich Groundwater, Village WASHE Committee, Area Pump Menders, Community-led management models*

### Introduction

Rural areas in Zambia account for more than 60 per cent of the 13,092,666 people (CSO, 2011), but this population has low access to basic services including improved water sources. In 2005 access to safe water supply for the rural population was estimated at 37 per cent (MLGH, 2015) while the proportion of the rural population with access to an improved water source increased from 41.9 per cent in 2006 to 51.4 per cent in 2010 (UNDP, 2013). The driver was the sector-wide reform initiated in the mid 1990's which culminated in the establishment of new institutions and legal frameworks. One such institution was the Department of Housing, Infrastructure and Support Services (DHISS) responsible for water supply and sanitation including the mobilisation of resources to maintain and expand infrastructure and service provision under the Ministry of Local Government and Housing (MLGH). As a consequence, the National Rural Water Supply and Sanitation Programme (NRWSSP) was elaborated and developed in 2005 to guide all government and donor interventions in water supply and sanitation (WSS) in rural areas (GRZ, 2005) and, since then the NRWSSP has been directing all interventions and interventions in WSS in rural areas of Zambia. The component of operation and maintenance (O&M) of NRWSSP was designed to contribute to the achievement of the Programme objectives by ensuring that the operational rate of water supply facilities were at 70-80 percent all the time Agency (JICA) (GRZ and JICA, 2013). The core approach adopted was the Sustainable Operation and Maintenance Project (SOMAP) O&M mechanism and model which were developed and tested in two phases of the for Rural Water Supply (SOMAP1 and SOMAP2) implemented by the Ministry of Local Government and Housing with the technical cooperation by Japan International Cooperation Agency (JICA) (GRZ and JICA, 2013).

## SUSTAINABLE SERVICES

### Community Managed Supplies

Amongst the many objectives that guided the reform process in Zambia, two of these were of direct bearing on strengthening community-based management, namely: promoting community management and integration of hygiene education in rural WSS; development of human resource capacity by promoting training in all institutions and Water, Sanitation and Hygiene Education (WASHE) training in rural areas (NWASCO, 2004). Despite the strong emphasis on community-based management in all rural WSS interventions, maintenance of these water supply sources have largely remained a very big challenge. A number of hand pumps were abandoned simply because they had not been repaired and thus not working while others were abandoned because of the poor quality of water due to high iron concentration in groundwater. Area pump menders (APMs) are tasked, within their areas of jurisdiction, to maintain and repair hand pumps and ensure that they were always in good working condition. The presence of a number of abandoned hand pumps unfortunately suggested that community-led management models had failed: Village Water, Sanitation and Hygiene Education Committees (V-WASHE) were non-functional; APMs had turned out to be very forceful, betrayed the cause of their communities and acted with utmost impunity as the system lacked adequate mechanisms to regulate them. In addition, maintenance fees charged by APMs were excessive and way above the range of approved maintenance fees. As a result, some hand pumps had evidently been vandalised by APMs because of the failure by communities to raise the demanded maintenance fees. It was common practice by APMs to remove parts of the hand pump, i.e. chain, hand pump head, etc., whenever communities were short of the demanded fees. Overall, the situation was further exacerbated by either the ineffectiveness of the community-led management model which in turn was compounded by the unclear reporting systems.

Community-led management of water supply in rural parts of Zambia is implemented through the Village Water Sanitation and Hygiene Education (V-WASHE) Committees who in turn are coordinated and supported by the District Water Sanitation and Hygiene Education (D-WASHE) Committees. D-WASHE Committees are a district level committee that are part of the formal district level planning process. They are constituted by representatives of government departments and institutions. The D-WASHE Committee is a sub-committee of the District Development Coordinating Committee (DDCC) and it is chaired by the Local Authority (Town Clerk or Council Secretary). The DDCC, on the other hand, is chaired by the District Commissioner while the Local Authority (Town Clerk or Council Secretary) is the vice chairperson.

This paper, therefore, looks at community-led management practices of improved water supply sources – particularly boreholes fitted with hand pumps – in rural parts of Zambia. It draws lessons from interventions made in rural areas of Central Province as well as Luapula, Muchinga and Northern provinces which were aimed at increasing access to improved water supply to local communities through two projects, namely: Central Province Rural Water Supply and Sanitation Project implemented from 2000 to 2007, and Rural Water Supply and Sanitation Project in 15 Districts of Luapula, Muchinga and Northern provinces implemented from 2010 to 2015. Importantly, both projects were also designed to contribute to communities that were better organized in managing their own water and sanitation services in a more sustainable approach.

#### Context, aims and activities undertaken

Water supply and sanitation (WSS) interventions in rural areas of Zambia from two projects were assessed. These are the Central Province Rural Water Supply and Sanitation (CPRWSS) Project which was implemented from 2000 to 2007 and the National Rural Water Supply and Sanitation (NRWSS) Project in 15 Districts of Luapula, Muchinga and Northern Provinces which was implemented from 2010 to 2015. While WSS interventions in Luapula, Muchinga and Northern provinces were implemented in 15 districts, WSS interventions in Central Province (CPRWSS Project) were implemented in four districts. A total of 3,477 water points were provided under the CPRWSS Project (AfDB, 2008) while a total of 2,653 water points were planned to be provided under the NRWSS Project, out of which 777 were supposed to be rehabilitations and 1,876 new water points (GRZ, 2015). However, only 1,847 new water points were

## SUSTAINABLE SERVICES

### Community Managed Supplies

constructed and a total of 1,847 V-WASHE committees trained and formed to manage the affairs of the water points (GRZ, 2015).

The assessment was aimed primarily at measuring the impacts WSS interventions had made to the local communities where these projects were implemented. Primary data was therefore collected from households through a household questionnaire. Other sources of primary data were focus group discussions (FGDs) as well as interviews with key informants. A total of 1000 households (500 households per project) were interviewed in the four districts of Kapiri Mposhi, Serenje, Samfya and Kasama districts – 300 household questionnaires each were administered in Kapiri Mposhi and Kasama districts and 200 household questionnaires each administered in Serenje and Samfya districts. Kapiri Mposhi and Serenje districts are in Central Province while Samfya and Kasama districts are in Luapula and Northern provinces, respectively. Despite planning for two (2) FGDs in each district, only one (1) FGD was held in Samfya District. Therefore a total of seven (7) FGDs were held during the assessment.

Stratified systematic sampling was used for primary data collection from households. The systematic approach guided the sampling pattern for the different beneficiary groups (i.e. schools, communities, health centres, and chief palaces). Sample population in each group was proportionate to the actual number of boreholes that were drilled and equipped with hand pumps for each project.

Community water points (boreholes drilled in communities) were entry points for each research area. Equal number of households were selected as respondents based on two aspects, namely: i) the geographical location of the household (i.e. north, south, west and east compass bearing with reference to the community water point), and ii) spatial location of the household (i.e. every other household, i.e. 1<sup>st</sup>, 3<sup>rd</sup>, 5<sup>th</sup>... etc., households). Therefore from each community water point, every other household located north of the water point was sampled until the last household was interviewed. This process was then repeated for households located in the south, west and east of the water point respectively, until the sample population in that community was achieved.

### Main results and lessons learnt

The majority of respondents in all the four districts (Kapiri Mposhi and Serenje (CPRWSSP); Samfya and Kasama (NRWSSP)) were female. Female respondents in Kapiri Mposhi and Serenje districts made up 51.8 percent of respondents while those in Samfya and Kasama districts constituted 57.8 percent. Despite this, majority of households in all the four districts were male-headed households – 64.8 percent in Kapiri Mposhi and Serenje districts and 74 percent in Samfya and Kasama districts. There were 35.9 percent of household members that were above 18 years old in Samfya and Kasama districts and 33.9 percent in Kapiri Mposhi and Serenje districts. Therefore it was obvious that over a third of the population were generally matured enough to be effectively involved in community management of their improved water supply sources.

The common form of occupation by majority of the population in Samfya and Kasama districts was farming in which 89.6 percent of respondents were engaged. Classified Daily Employees and sole trading represented 3.4 per cent and 2.4 per cent, respectively. Other forms of employment included health workers, teachers and judiciary services workers. Health workers represented 0.8 per cent of respondents while teachers represented 0.2 per cent, so were judiciary services workers. Similarly, 84.6 percent of respondents in Kapiri Mposhi and Serenje districts were farmers while 12.4 percent were in trading (family businesses) and an additional 2.2 percent of respondents depended on life skills such as bicycle repairing, bricklaying, welding and carpentry for their sources of livelihoods. Farming was typically subsistence in nature were families only grew enough crops for their family consumption but only sold excess harvests.

Different sources of water supply were used in all the four districts and these included boreholes, protected wells, unprotected wells and open surface water bodies. In general, some of the protected wells were modified and fitted with India Mark II hand pump and very rarely was the windlass used. In Samfya

## SUSTAINABLE SERVICES

### Community Managed Supplies

and Kasama districts, 68.5 percent of households collected water from boreholes for their drinking purposes while 16.5 percent of respondents collected their water from protected wells. In addition, 6.8 percent of respondents used unprotected wells as sources of water for their drinking uses although 8.5 percent of respondents used open surface water bodies as sources for their drinking water requirements. In Kapiri Mposhi and Serenje districts, however, 80.6 percent of households depended on water supply from boreholes for their drinking purposes while 10.0 percent depended on unprotected wells for their drinking water supplies. Furthermore, 5.2 percent of respondents in Kapiri Mposhi and Serenje districts depended on protected wells for their drinking water supplies while 4.2 percent used open surface water bodies for their drinking water supplies (see table 1 for sources of water supply for household uses).

**Table 16: Sources of water supply for household uses**

Uses	Water source types (percent)							
	Kapiri Mposhi and Serenje districts				Samfya and Kasama districts			
	Bore hole	Protect ed well	Unprotect ed well	Surface waterbodi es	Boreho le	Protect ed well	Unprotect ed well	Surface waterbodi es
Drinking	80.6	5.2	10.0	4.2	68.5	16.5	6.8	8.5
Cooking	80.4	5.0	10.6	4.0	68.5	16.5	6.8	8.5
Bathing	79.6	5.4	10.8	4.2	73.1	13.8	5.4	7.7
Washing clothes	79.6	5.8	10.4	4.2	74.6	13.1	4.6	7.7
Washing utensils	79.6	5.4	10.8	4.2	74.6	13.1	4.6	7.7

**Source: Author's research findings data analysis (2016)**

Therefore, the primary source of drinking water supply in all the four districts were boreholes, as such effective community-led maintenance systems was critical to guaranteeing continued operations of boreholes for optimal service provision to the local communities.

It was common for communities in all the four districts to rely on multiple sources of water supply for their household requirements. In Kapiri Mposhi and Serenje districts for example, 90.4 percent of respondents relied on between two (2) and seven (7) sources of water supply compared to 9.6 percent that depended on only one (1) source. This situation was mirrored in communities in Samfya and Kasama districts where 6.8 percent of respondents wholly depended on one (1) source of water supply compared to 93.2 percent that depended on between two (2) and seven (7) sources of water supply. This dependency on multiple sources of water supply by communities in the four districts indicated the lack of reliability of water supply from improved water sources. This, therefore, showed that not all water sources were functioning in all the four districts. A total of 53.7 percent of respondents in Kapiri Mposhi and Serenje districts, for instance, had reportedly between one (1) and four (4) water sources abandoned in their respective communities compared to 43.6 percent of respondent where none of water sources were abandoned within their communities.

Similarly, not all water sources were functioning in Samfya and Kasama districts. The number of abandoned water sources ranged from a minimum of one (1) to a maximum of six (6). A total 61.2 percent of respondents had reportedly abandoned between one and four water supply sources within their communities while 38.4 percent of respondents had reportedly abandoned none of their available water supply sources.

There were various reasons that led to abandoning water supply sources and these included: long distance to water supply source; poor water quality; broken down water supply points (not functioning); personalization of boreholes; failure to contribute towards O&M; protected well collapsed, and dried up water points (see Table 2 for collated summary of responses).

## SUSTAINABLE SERVICES

### Community Managed Supplies

**Table 17: Reasons for abandoning water points in the four districts**

Reason	Kapiri Mposhi and Serenje districts		Samfya and Kasama districts	
	Frequency	Valid per cent	Frequency	Valid per cent
Dried up water points	74	26.4	11	3.6
Declining groundwater levels	6	2.1	-	-
Long distances to water points	3	1.1	112	36.4
Restricted access; borehole personalised	7	2.5	1	0.3
Poor water quality; i.e. rusty, dirty water	36	12.9	31	10.1
Water points broken down and not functioning	154	55.0	144	46.8
Failure to contribute towards O&M	-	-	1	0.3
Protected well collapsed	-	-	8	2.6
<b>Total</b>	<b>280</b>	<b>100.0</b>	<b>308</b>	<b>100.0</b>

Source: Author's research findings data analysis (2016)

The main reason for communities abandoning water supply points in all four districts was the breaking down of hand pumps (55 percent of respondents in Kapiri Mposhi and Serenje districts and 46.8 percent of respondents in Samfya and Kasama districts). This was followed by the drying up of water points for communities in Kapiri Mposhi and Serenje districts while in Samfya and Kasama districts the second reason was the long distance. The long distance to water supply points made 36.4 percent of respondents in Samfya and Kasama districts not to use alternative water supply sources. The third most common reason that forced communities to abandon their water supply sources was the poor quality of the water (see table 2).

Broken down hand pumps pointed to the lack of maintenance. Maintenance of boreholes was a function of area pump menders (APMs). APMs are volunteers from amongst the community members that were trained in the operation and maintenance (O&M) of hand pumps, and were generally paid in kind or cash as prescribed by District WASHE Committees. Payments made to APMs by communities were fundamentally meant as motivation and not as wages. Ideally, each beneficiary community contributed to the sustainable management of boreholes and this was mainly achieved through mobilizing households to regularly contribute towards O&M of the water point. This, unfortunately, was never the case for majority of communities but where this was done, it was often reactive in nature – i.e. contribution only made when a hand pump broke down. In majority of cases where communities only made the contributions when the hand pump broke down, it was also common that such contributions were often not adequate to cover the full cost of repairs (spare parts and labour) and thus hand pumps were never repaired.

Nonetheless, it was obvious that the presence of active and dedicated APMs provided long term sustainability to rural water supply infrastructure. Unfortunately, APMs were absent in majority of communities in all the four districts assessed. In Samfya and Kasama districts, for instance, only 31 percent of respondents revealed that they had active and dedicated APMs in their areas while 69 percent did not have active and dedicated APMs within their communities. The same trend was shown in Kapiri Mposhi and Serenje districts where 30.8 percent of respondents had active and dedicated APMs within their communities compared to 69.2 percent of respondents that did not have active and dedicated APMs within their communities.

Besides the absence of APMs in majority of communities, fees demanded by APMs were generally very high. Majority of communities failed to meet the costs demanded by area pump menders. In Samfya and Kasama districts, APMs charged as high as ZMW 350 whilst those in Kapiri Mposhi and Serenje districts

## SUSTAINABLE SERVICES

### Community Managed Supplies

charged at most ZMW 200 for repairing of a hand pump. Maximum amount recommended by D-WASHE as community appreciation for services provided by APMs was ZMW 100. In addition to those exorbitant fees demanded by APMs, access to spare parts was an issue to majority of communities. Whilst some communities bemoaned the high costs of spare parts, other communities had no information on where to go for spare parts.

The difficulty of communities not affording the cost for repairing hand pumps would have been eased by regular contributions from households. Ideally, communities were encouraged to contribute towards maintenance of hand pumps once monthly to avoid being overburdened once the hand pump broke down. Nevertheless, it was common practice for communities to contribute towards maintenance of hand pumps only when the hand pump broke down. Only 9 percent contributed regularly towards maintenance of water point in Samfya and Kasama districts compared to 91 percent that did not. Similarly, in Kapiri Mposhi and Serenje district only 8.1 percent contributed regularly towards maintenance of hand pump while 91.9 percent never contributed regularly towards the maintenance of water supply point. It was therefore clear that, the tradition to regularly contribute towards maintenance of water points was absent. This, nonetheless, needed to be strengthened if community-led management models of rural water supply had to be realised.

The other reason linked to the lack of regular maintenance of water points was the absence of effective area water committees, the V-WASHEs. Even though V-WASHEs were established during the course of project implementation, these committees were largely non-existent while in communities where they existed, they were generally ineffective. It was apparent that not enough effort and time was invested in establishing functioning V-WASHEs. Majority of V-WASHEs were formed just before the drilling of boreholes and hence they hardly made any inroads in assuming meaningful ownership of the water points. Furthermore, very limited training was given to V-WASHEs both during project implementation as well as post project implementation. As a result, it was not surprising to learn that majority of V-WASHE committees become moribund just months after their formation. As such, community members had nowhere to report to whenever water points broke down. This unfortunate state was further exacerbated by the ‘not-so-clear’ reporting channels within community-led rural WSS management system to which APMs took advantage. It was evident, therefore, that APMs wielded a lot of power within communities – obviously taking advantage of gaps within reporting lines – and could vandalise water points at will, knowing very well that they would neither be reprimanded nor sanctioned by the V-WASHE. Inappropriately so as the situation may appear, some water points were abandoned merely because APMs had wilfully removed either a pump head, a chain or even riser mains, rods and pump from boreholes for the simple reason that the affected communities failed to raise enough money to meet their demanded costs of repairing the hand pump.

Full community participation appeared to also have lacked in both projects. Communities were largely used as instruments for the ‘smooth’ implementation of projects in their respective areas other than as ‘equal’ implementation partners. Little or no community mobilization post project implementation was observed in all the four districts although this was mostly blamed to inadequate staffing levels at District Rural Water Supply Unit as well as time and financial constraints. There was only one officer responsible for rural water supply and sanitation at local authority level in all the four districts and none of the districts had a coherent plan on building the capacities of V-WASHEs. Therefore, community-led management structures that were established at project implementation were not only deprived of the much needed nurturing and mentorship from the District but also continued to exist without fundamental skills in organizational management and leadership. In addition, it was apparent that the two structures (grassroots structures (V-WASHE) and district structures (D-WASHE)) existed in complete isolation – there was no evidence of V-WASHE involvement in planning interventions in rural WSS or being consulted for purposes of providing inputs into the broader RWSS plans for the districts. As such, more focused support and interventions were required not only in ensuring that the identification of locations for water points were done in sufficient consultation with women in order to ensure ownership, proper usage and sustainability for the infrastructure but also strengthening the grassroots structures. Furthermore, V-WASHEs needed to be continuously trained and exposed to skills in organizational

## SUSTAINABLE SERVICES

### Community Managed Supplies

management and leadership, particularly records and book keeping; participatory approaches; community resource mobilization techniques; general hand pump maintenance techniques; hygiene education as well as gender sensitisation for them to become effective.

High iron content in groundwater was the main cause of the poor quality of the water. High iron had been reported in some boreholes in all four districts. GRZ and JICA (2013) reported high iron content in majority of groundwater as well as aggressive pH environment in their study conducted in Luapula, Central, Northwestern and Copperbelt provinces. The preliminary results from the 1<sup>st</sup> Field Water Quality Analysis showed that ‘...Most readings except on Mapipo village water point were greater than 10mg/l with a few varying between 1.89 to 7.5 mg/L, but still above the ZABS drinking water standards. This shows that all sites selected (excluding Mapipo) had problems of high iron levels’ and ‘...All measured pH readings were less than 7 and varied from 5.56 to 6.89 suggesting fairly acidic conditions though within the drinking water standard limit’ (GRZ and JICA, 2013). The Zambia Bureau of Standards (ZABS) iron standards in drinking water is 1 mg/l while that of pH is 6.5-8 (ZABS, 2010) Therefore, from the 1<sup>st</sup> Field Water Quality Analysis GRZ and JICA (2013) concluded that all water points were under acidic conditions (pH < 6.8) and very low alkalinity suggesting a corrosive environment, and that all abandoned water points had elevated iron levels beyond acceptable ZABS standards for drinking water (water was brown in colour and with a metallic taste suggesting corrosion). However, a decrease in iron concentration in groundwater was noted upon cleaning (purging) the boreholes. Iron content was higher than 2 mg/l except on Mapipo village, where iron was within the limit before cleaning (purging) the boreholes but it became less than 1 mg/l on several sites except for Mapipo after the boreholes were purged (GRZ and JICA, 2013). As a result, GRZ and JICA (2013) concluded that water types on all sites were fresh. This, therefore, suggested that iron was being introduced into the borehole through other sources other than the natural geological formation environment. Consequently, GRZ and JICA (2013) determined that the iron measured from the selected samples was from corroded components of the water point and not from the geological formation. This was supported by the fact that iron concentration in groundwater decreased significantly after borehole cleaning and introduction of Afridev hand pump fitted with stainless steel rods. It has to be emphasized, nonetheless, that in some areas the elevated iron content in groundwater was because of the natural geological formation environment and these needed a different solution, i.e. the use of iron removal filters. Therefore, high iron concentration in groundwater was attributed to either natural environment or leaching from galvanized iron (GI) pipes and rods because of the aggressiveness of the groundwater.

Other causes of poor water quality were suspended solids. Very high suspended solids contents in some borehole water were also observed especially in Samfya District. This incident, nevertheless, was not very widely spread. The main explanation for high contents of suspended solid was the poor workmanship which could have been averted through effective supervision of the drilling contractor.

Just as putting in place a functional V-WASHE was important, establishing the quality of groundwater prior to completing the construction of the water supply point was also cardinal. Groundwater quality sampling and analysis is an important component of the rural water supply system and should be done preferably at pumping test stage before commencement of any construction works. The groundwater quality results should inform the eventual completion of the water supply point: whether or not the construction to be done; construction of the water point with peripheral structures such as iron removal systems; type of riser pipes, rods and pump to be used, i.e. stainless versus galvanized iron (GI), etc. The use of water quality data to inform the technical aspects of rural WSS projects in the four districts appeared to have been incoherent. In Samfya and Kasama districts for example, while water quality analysis was done, there was no proof however that this inputted into the eventual completion of water supply points. This was evidenced from the fact that groundwater was generally aggressive (low pH) but GI riser pipes, rods and pump were still used. In addition, some water points with high iron concentration levels were not equipped with iron removal filters.

Despite this, there are a number of lessons to be drawn from the study and these broadly covered all aspects of rural WSS chain, namely: systems and structures; governance and technologies. In order to strengthen community-based management of water supply resources, it was fundamental that

## SUSTAINABLE SERVICES

### Community Managed Supplies

community-led rural WSS management models were made more effective and functional. V-WASHEs needed to be much more engaged if they were to be relevant and contribute to community ownership of water supply infrastructure. A self-motivated V-WASHE was therefore fundamental to a strengthened community-based management of water supply sources especially because serving on the committees was purely based on voluntarism. Some of the lessons gained from the assessment are as follows:

#### ***It takes long to anchor and nurture V-WASHEs***

A lot of time and support is required in establishing V-WASHEs. Prior to the construction of a water supply point and in order for V-WASHEs to be effective, a lot of capacity has to be built within the committee. This requires an adequate lead-time of structured training culminating into the general understanding of all aspects of their water supply.

#### ***Software key to community-led RWSS management model***

Long term sustainability of rural water supply is founded on effective operation and maintenance of the water supply infrastructure. Communities would only take appropriate actions once they know why such actions are necessary. The case in point is the failure to sustain regular community contribution towards the maintenance of water supply points. It is only through effective communication and community engagements were such issues could be resolved.

#### ***Community ownership in never realised without full community input***

Rural WSS interventions should be led by community members. Communities should select sites for water points and should be fully involved in supervising their construction. Records of construction supervision reports compiled by community members should be kept at grassroots structures (V-WASHEs) and be used as management tools.

#### ***Groundwater quality analysis must take place before the construction of water point***

Completion of construction of water points should only be done once the groundwater quality analysis reports have been conducted. The use of stainless steel riser mains, rods and pump in aquifers with aggressive groundwater (low pH) would guarantee the long-term supply of good quality water to rural communities, so is the use of iron filters in groundwater with naturally high iron concentration. Otherwise, confidence in hand pumps by rural communities will continue to be eroded while substantial amounts of money lost through abandoned water supply points.

#### ***D-WASHEs oversight of V-WASHEs vital in improved management of RWS***

Continued provision of support, training and capacity building programmes by D-WASHEs is important to developing a responsive community-led management tier. D-WASHEs should also provide full oversight to V-WASHEs as well as an active platform for community interaction. Regular visits of V-WASHEs by D-WASHEs would provide the needed motivation to grassroots structures.

#### ***Linking V-WASHEs into already established community-led initiatives particularly in health sector is vital***

The lack of funds to sustain community-led management activities should not be reasons enough for V-WASHEs to be ineffective. Community-led programmes have been successfully implemented in the health sector, i.e. Neighbourhood Health Committee (NHCs). Therefore linking V-WASHEs activities into NHCs programmes would be beneficial to strengthening community-led water supply management models.

## Conclusions and Recommendations

In line with the goal of the National Rural Water Supply and Sanitation Programme of providing sustainable access to water supply and sanitation in rural areas so as to contribute towards poverty alleviation of Zambia's rural population (GRZ, 2007), interventions in WSS were supported in 15 district of Luapula, Muchinga and Northern provinces as well as Central Province. Key to rural WSS interventions are the promotion of community management and integration of hygiene education as well



## SUSTAINABLE SERVICES

### Community Managed Supplies

as development of human resource capacity by promoting training in all institutions and WASHE training in rural areas. Therefore, the impact of the interventions was assessed with regards to the success of community-led management practices of rural water supply points.

It was obvious from the assessment that although V-WASHEs were established at all water points that were constructed by the two projects, these committees were no longer existing or functioning. Not enough time was given for nurturing and developing the V-WASHEs. There was also very little investment that were made into building the capacities of V-WASHEs (i.e. provision of targeted trainings). This was further exacerbated by the unclear reporting channels of the V-WASHEs as well as the absence of effective oversight that D-WASHEs failed to provide to V-WASHEs.

Furthermore, it was noted that majority of water points were abandoned because they were no longer working. Lack of maintenance was the main reason attributed to water points not working. In majority cases, communities had failed to raise moneys demanded by APMs for repairing hand pumps. Moneys demanded by APMs for repairing hand pumps were generally high – ranging from a minimum of 100 percent to a maximum of 250 percent higher than the accepted maximum allowable fees. Nevertheless, the failure by communities to regularly contribute towards the maintenance of water supply points attributed to their inability to meet the costs for repairing of hand pumps demanded by APMs.

Other reasons for abandoning the water supply points were the poor water quality. High iron concentration in groundwater was the main reason for the poor quality of the water. Sources of high iron concentration in groundwater were either due to the natural environment or corroded GI pipe riser main, rods and pumps because of the low pH (aggressive groundwater). Therefore, good borehole designs are fundamental. Best practices in planning and developing groundwater source for water supply should always be ensured.

Therefore, in order to strengthen community-based management of rural water supply schemes, the following have been recommended:

- (i) Invest adequately in establishing community-led management structures both in terms of time and training
- (ii) Provide adequate time for the software component of RWS projects to be implemented
- (iii) Tap RWS grassroots structure into already existing government interventions that have succeeded
- (iv) Ensure full and effective community ownership is essential for a successful community-led management intervention
- (v) Stronger and active D-WASHEs leads to a stronger and active V-WASHEs – building strong community-led management structures are a continuous process
- (vi) Use of technologies that is responsive to local environments would guarantee continued access to water supply sources
- (vii)

### References

- AfDB (2008) *'Zambia: Central Province Rural Water Supply and Sanitation Project - Project Completion Report'*, Africa Development Bank Group, Abidjan
- CSO (2011) *'2010 Zambia Census of Population and Housing'* Central Statistical Office, Lusaka
- GRZ (2005) *'National Rural Water Supply and Sanitation Programme: 2006 – 2015 (NRWSSP)'*, Ministry of Local Government and Housing, Lusaka
- GRZ and JICA (2013) *'Consulting Services for Water Quality Analysis and Monitoring through Hand pump Replacement for the Project for Support in National Roll-out of Sustainable Operation and Maintenance Programme (SOMAP3)'* Lusaka
- GRZ (2015) *'National Rural Water Supply and Sanitation Programme Support to the 15 Districts of Luapula, Muchinga and Northern Provinces under Financial Support of the African Development Bank: Project Implementation Completion Report'*, Ministry of Local Government and Housing, Lusaka
- NWASCO (2004) *'Water Sector Reform In Zambia'*, National Water Supply and Sanitation Council, Lusaka

## SUSTAINABLE SERVICES

### Community Managed Supplies

UNDP (2013) *Millennium Development Goals Progress Report: Zambia*, United Nations Development Programme, New Horizon Printing Press, Lusaka

ZABS (2010) *Drinking Water Quality Specifications*, Zambia Bureau of Standards, Lusaka

## SUSTAINABLE SERVICES

### Community Managed Supplies

# Renforcement de la résilience des communautés rurales à travers la mise en œuvre de l'approche « sécurisation des ressources en eau »

Type : Article Long

**Auteur :**

**Djibril BARRY**, Chargé de projet, WaterAid Burkina

[djibrilbarry@wateraid.org](mailto:djibrilbarry@wateraid.org)

Tel : (00226) 25 37 41 70/Fax : (00226) 25 37 60 11

**Co-Auteur :**

**Léon OUEDRAOGO**, Chargé de la documentation et du suivi de la recherche, WaterAid, Burkina Faso

[leonouedraogo@wateraid.org](mailto:leonouedraogo@wateraid.org) tél. : 70 65 88 06

### Abstract/Résumé

L'approche sécurisation des ressources en eau renforce la résilience des communautés. Elle est en cours d'application dans 14 communautés rurales du Burkina par WaterAid, le Régional Learning Center for Water Resources Management (RLC/WRM), l'ONG Dakupa et les communes de Tenkodogo et Lalgaye à travers le projet « Réduction des risques de Catastrophes ». Le but est d'améliorer la qualité de vie et de renforcer les moyens de subsistance des communautés par l'amélioration de l'accès à l'eau, l'accroissement de la connaissance des communautés et la mise en place d'un système d'information pour la gestion locale de l'eau. L'action est à sa 4ème année de mise en œuvre dans les anciens villages et à sa 2<sup>e</sup> année dans les 10 nouveaux villages avec des effets perceptibles. En effet, le profil des villages bénéficiaires a considérablement varié depuis le démarrage du projet. Une dynamique positive est en marche avec une prise de conscience collective sur la problématique locale de la ressource et une volonté des communautés à renforcer leur résilience.

### Introduction

Les questions des changements climatiques et de la résilience des populations sont au cœur des débats sur le développement socioéconomique. Les prévisions climatiques sont alarmantes. Les risques de catastrophes naturelles sont de plus en plus élevés avec un impact certain sur la ressource en eau. Quel mécanisme de préservation des ressources en eau mettre en place pour en améliorer l'accès des communautés ? En se basant sur une expérience locale au Burkina, WaterAid présente ici des pistes de solutions.

WaterAid est une organisation internationale qui travaille dans de nombreux pays pour offrir aux populations vulnérables l'accès à l'eau potable, à l'hygiène et à l'assainissement. En Afrique de l'Ouest, l'organisation intervient dans sept (07) pays que sont le Burkina Faso, le Mali, le Niger, le Ghana, le Nigéria, la Sierra Léone et le Libéria. Les résultats de l'organisation dans ces pays sont menacés par les risques liés aux effets des changements climatiques dans la mesure où les fortes pluies et les inondations détruisent les infrastructures d'approvisionnement en eau et les latrines, contaminant ainsi les sources d'eau potable. Les dysfonctionnements des systèmes d'approvisionnement en eau et d'assainissement forcent les Communautés à recourir à la consommation de l'eau non potable et à la défécation à l'air libre, encourageant ainsi la propagation des maladies à un moment où les ressources de santé et de soutien sont particulièrement limitées. Pour ce faire, WaterAid, a lancé une initiative pilote visant à renforcer l'impact de son intervention et la résilience des communautés vulnérables aux effets des changements climatiques dans cinq (05) pays d'Afrique de l'Ouest dont le Burkina Faso. L'initiative de réduction des risques de catastrophes s'inscrit dans la mise en œuvre des politiques et stratégies définies par le pays. L'action de WaterAid s'insère dans les axes ci-après :

## **SUSTAINABLE SERVICES**

### **Community Managed Supplies**

- l’amélioration de l’accès des populations à l’eau potable et à l’assainissement ;
- la maîtrise d’ouvrage communale dans le secteur de l’eau potable et de l’assainissement ;
- le renforcement de l’adaptation à la variabilité et aux changements climatiques ;
- l’adoption de l’approche gestion intégrée des ressources en eau.

#### **1-Contexte, objectifs et activités**

Au Burkina Faso tout comme dans les autres pays de l’Afrique de l’Ouest, les approches d’Approvisionnement en Eau Potable Hygiène et Assainissement (AEPHA) ont traditionnellement mis l’accent sur la fourniture de moyens d’approvisionnement en eau en accordant peu de considération aux menaces pesant sur les ressources en eau. Pourtant les menaces (inondations, sécheresses, etc.), de plus en plus récurrentes et très violentes réduisent les immenses efforts consentis par les différents acteurs pour la réalisation de l’accès durable aux services d’AEPHA. L’initiative réduction des risques de catastrophes vient renforcer les approches d’AEPHA pour mieux prendre en compte des menaces du moment.

Au Burkina Faso, l’initiative est mise en œuvre dans la région du centre-est du Burkina Faso. La zone d’intervention fait partie du sous bassin hydrographique de la Nouhao dont le principal fleuve « la Nouhao » est un affluent du fleuve Nakanbé. En plus du fleuve « la Nouhao », le réseau hydrographique se compose des affluents primaires de la Nouhao (le fleuve Koubila et Sablogo) et de nombreux affluents secondaires. Au total quatorze (14) villages identifiés sur la base de l’analyse de données caractérisant leur résilience ou vulnérabilité aux effets du changement climatique, ont été retenus pour bénéficier de l’intervention du projet. Ces quatorze (14) villages sont répartis entre les communes de Tenkodogo (province du Boulgou) et de Lalgaye (province du Koulpélogo).

#### **2-Pourquoi intégrer la réduction des risques de catastrophes à la mise en œuvre des programmes d’AEPHA ?**

##### **2.1-La disponibilité de l’eau varie dans le temps et dans l’espace**

La capacité à fournir de l’eau pour les usages socioéconomiques à partir des eaux de surface (barrage, cours d’eau..), des nappes phréatiques (puits) et profondes (forages) dépend fondamentalement de la disponibilité de la ressource et des moyens technologiques. Que ce soit les eaux de surface ou les eaux souterraines, celles-ci subissent actuellement l’effet des changements climatiques sur leur quantité et leur qualité à travers une variation spatio-temporelle de la pluviométrie avec parfois des inondations dans des zones qui n’en connaissaient pas d’habitude et des sécheresses à des périodes culturelles critiques engendrent des catastrophes.

##### **2.2-Les ressources en eau subissent une pression**

La croissance démographique et économique entraîne une forte demande en eau et peut entraîner un conflit d’usage : conflit entre la consommation humaine et les besoins des activités économiques. En l’absence d’un cadre pertinent de planification et de gestion des ressources en eau, le risque de catastrophe devient élevé dans ce contexte.

Dans les zones arides et semi-arides comme le Burkina Faso, la ressource en eau de surface est généralement non pérenne et se limite à la période hivernale qui ne dure que 4 mois. Les ressources en eau souterraine supportent les besoins en eau des communautés surtout rurales à travers les puits et les forages qui sont en nombre insuffisant (soit en moyenne 1 Pompe à motricité humaine (PMH) pour 300habitants). En saison sèche, les femmes et les jeunes enfants consacrent beaucoup de temps d’attente au point d’eau pour s’approvisionner. Dans ces conditions, certaines activités ont du mal à prospérer notamment les activités de production de contre-saison (maraichage, pépinière, ...), d’élevage et certains besoins domestiques autres que la boisson sont affectés par le manque d’eau (lessive dont la fréquence baisse entraînant des problèmes d’hygiène vestimentaire, ou le lavage des ustensiles qui ne sont pas bien faites entraînant des problèmes d’hygiène alimentaire). Et pourtant ces conflits d’usage pourraient être atténués avec une planification et une bonne gestion des ressources en eau disponible.

## SUSTAINABLE SERVICES

### Community Managed Supplies

#### 3-Que propose WaterAid comme solution face à l’insécurité de l’eau dans le contexte du changement climatique ?

En réponse à ce contexte, WaterAid s’est approprié le principe de « gestion participative des ressources en eau » pour développer un programme de mise en œuvre de l’approche « sécurisation des ressources en eau » dénommé « Programme de réduction des risques de catastrophes en Afrique de l’Ouest (Burkina, Mali, Niger).

**L’approche Sécurisation des ressources en eau (SWRA) :** elle met l’accent sur la sécurisation de l’eau au profit des communautés en se fondant sur 8 principes : 1-Mener des recherches pour comprendre les facteurs et la pression qui affectent la ressource; 2-Connaitre le bilan d’eau; 3-Identifier les menaces aussi bien locales que lointaines sur la ressource, les moyens de subsistance...; 4-Comprendre comment les communautés gèrent l’eau et les conflits; 5-Suivre la dynamique de la ressource; 6-Favoriser le dialogue entre usagers; 7-Favoriser la prise de décisions concertées; 8-Prendre des mesures pour améliorer la sécurité de l’eau.

En terme opérationnel, WaterAid procède à la mise en œuvre de l’approche à travers la logique suivante :

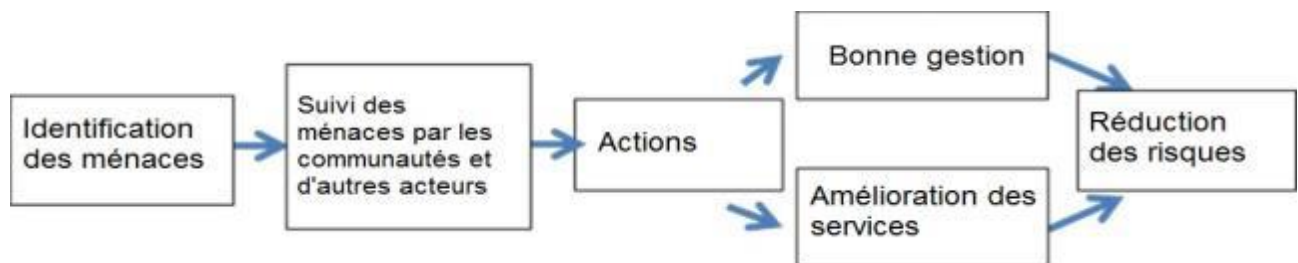

Figure 57. WaterAid-Logique d’intervention/ Source : Note conceptuelle RLC-WRM/WaterAid

Le programme « **Réduction des risques de catastrophe en Afrique de l’Ouest** » : est une initiative dont le but est de à doter les communautés de compétences et de savoir-faire pour résister aux catastrophes et garantir durablement une meilleure qualité de vie et de moyens de subsistance. Au Burkina Faso, le programme procède par la mise en œuvre de l’approche « sécurisation des ressources en eau » dans 14 communautés de la région du Centre-Est. Il constitue la mise en échelle et l’amélioration d’initiatives de gestion des ressources en eau menée par WaterAid depuis 2007 dans la même zone telles que l’introduction de technologies innovantes de captage d’eau de pluie (impluvium), construction d’ouvrage d’infiltration et de stockage d’eau de pluie (barrage de sable) et le suivi communautaire des ressources en eau.

#### 4-La démarche de mise en œuvre du programme au Burkina Faso

##### 4.1-Presentation de la démarche de WaterAid

L’essentiel pour WaterAid est de susciter une prise de conscience et une dynamique communautaire autour de la question de gestion des ressources en eau. Pour ce faire, WaterAid a opté de renforcer les capacités des communautés à travers leur initiation à l’utilisation d’instrument et d’outils scientifique adapté au contexte. Ainsi, Pour WaterAid il ne s’agit pas en premier ressort de générer des données scientifiques de qualité, mais plutôt d’apporter aux communautés la preuve des menaces qui planent sur leurs ressources en eau. En second ressort, WaterAid conscient des opportunités d’influencer les politiques en matière de planification et de gestion des ressources en eau et l’impérieuse nécessité de fonder les analyses sur des évidences, envisage de mettre en place un dispositif qui génère des données qui pourront suivre un processus d’homologation et d’intégration dans la base de données nationales.

Ainsi, WaterAid initie les communautés à travers les lecteurs communautaires au suivi des fluctuations des ressources en eau souterraine et de la pluviométrie à travers des instruments simples que sont les sifflets (une adaptation de la sonde électrique), des sondes électriques (3 communautés ont été dotées de cet instrument pour plus de précision dans les mesures) pour le suivi des eaux souterraines et des pluviomètres (paysan et professionnel) pour le suivi de la pluviométrie. Chaque communauté dans laquelle le projet

## SUSTAINABLE SERVICES

### Community Managed Supplies

intervient désigne deux volontaires qui sont formés et un ou deux puits témoins sont identifiés dans le village pour le suivi hebdomadaire. Les références de base des puits sont enregistrés (coordonnées géographiques et profondeur) pour les besoins d'analyse. Les relevés se font un jour de la semaine très tôt avant que les usagers ne commencent les prélèvements. Ces deux volontaires font également le suivi de la pluviométrie à l'aide de pluviomètres installés dans chaque village. Les 14 villages disposent d'un pluviomètre paysan et 2 d'entre-elles (Noctenga et Sablogo) sont dotés en plus de pluviomètres professionnels qui sont suivis par les lecteurs du village. L'implantation des pluviomètres et la formation des lecteurs aux mesures de la pluviométrie ont été assurées par les experts de la direction générale de la météorologie du Burkina Faso. Les lecteurs utilisent les fiches de suivi pluviométrique validées par la direction générale de la météorologie et un cahier de suivi des puits témoins. Une animatrice est chargée de l'appui aux lecteurs et du suivi de la qualité des données à travers des vérifications périodiques. Les données collectées permettent aux lecteurs de tracer des graphiques qui illustrent les tendances de la ressource (tendance des fluctuations dans les puits témoins et la tendance de la pluviométrie). Ces graphiques sont ensuite présentés à deux occasions (en fin de saison pluvieuse et en fin de saison sèche) en assemblée villageoise pour que la communauté puisse percevoir les tendances de leurs ressources, envisager les conséquences en lien avec les pratiques d'exploitation de la ressource et de prendre des mesures idoines s'il y a lieu pour réduire les risques de pénurie d'eau ou d'assèchement prématuré des sources d'eau. Auparavant, les lecteurs ont reçu les formations sur le cycle de l'eau, la tracer et l'interprétation des graphiques pour animer les sessions d'assemblée villageoise. Dans les villages de Basbédo, Sablogo et Loungo, la collecte des données par les lecteurs est faite depuis 2011.

WaterAid procède parallèlement à l'appui aux services techniques en charge de l'eau pour le suivi de la nappe profonde. Ce suivi est fait à l'aide de 5 Data loggers qui sont paramétrés pour des relevés périodiques. Le niveau statique du forage est mesuré à l'aide d'une sonde et les recherches sont menées pour déterminer la profondeur de forage et de la côte d'installation pour les besoins d'analyse. Un agent dédié de la direction régionale en charge de l'eau est responsabilisé pour effectuer trimestriellement le suivi des data loggers. Les actions sont en cours pour opérationnaliser le suivi de la qualité de l'eau qui permettra à la direction régionale d'avoir une base de données qualité/quantité de la ressource. Les données disponibles des data loggers (depuis 2011 pour 3loggers) permettent d'avoir des graphiques et d'établir une cartographie des tendances des ressources en fonction des saisons (voir les exemples de graphique dans la partie résultat). A la longue, le service technique aura une masse de données qui leur permettra de faire des simulations, de planifier et d'envisager des mesures. Pour l'heure, ces données sont pour WaterAid une base pour influencer les services techniques en charge de la mise en œuvre de la politique nationale en matière d'eau pour s'intéresser à des méthodes simples de suivi de la ressource afin d'améliorer le processus de planification et de gestion des ressources en eau.

WaterAid apporte un appui aux lecteurs communautaires et à la direction régionale en charge de l'eau pour réaliser au mieux leur tâche. En outre WaterAid a constitué une base de données pour stocker à son niveau les données et procéder à des traitements et analyse en vue d'alimenter son action de plaidoyer qui accompagne la mise en œuvre de l'initiative « réduction des risques de catastrophe ».

#### 4.2-Les activités déroulées dans le cadre du projet

- **La situation de base et l'identification des menaces :** il s'agit d'une étude réalisée à l'aide de plusieurs outils de collecte de données (exploitation documentaire, méthode active de recherche participative, enquêteurs ménage, ...) dans les villages d'intervention afin de constituer une situation de base. Elle a abouti à un rapport sur les conditions de vie et de subsistance, les besoins en eaux, les menaces et les opportunités dans les 14 communautés.

## SUSTAINABLE SERVICES

### Community Managed Supplies



*Photo 1 : Discussion de groupe dans le village de Gaskom / Photo : WaterAid/Félicité Ilbondo*



*Photo 2 : Enquête ménage pour la situation de base / Photo : WaterAid/Félicité Ilbondo*

- **L'identification et le renforcement des capacités des lecteurs communautaires** : il s'agit de la tenue d'assemblées villageoises de restitution des conclusions de l'étude de base au niveau de chaque village qui permet une prise de conscience et une adhésion à la démarche du projet. Ainsi, les communautés désignent deux volontaires en tenant compte de la parité homme/femme pour être les lecteurs des instruments de mesure installés dans le village. Les lecteurs communautaires sont formés sur le cycle de l'eau, les techniques de mesures d'eau souterraine et de la pluviométrie et les techniques de tracer et d'interprétation des données. Le projet a contribué à la formation de 28 lecteurs communautaires issus des 14 villages d'intervention.



*Photo 3 : Formation des lecteurs communautaires aux relevés pluviométriques / Photo : WaterAid/Djibril Barry*

## SUSTAINABLE SERVICES

### Community Managed Supplies



*Photo 4 : Formation des lecteurs aux relevés de la variation d'eau dans les points témoins / Photo : Dakoupa/Ferdinand Kaboré*

- **Le suivi des ressources en eau par les communautés :** Les lecteurs communautaires formés sont dotés de cahier de suivi des eaux souterraines et de fiches de suivi de la pluviométrie. Le suivi des eaux souterraines est fait au niveau de puits témoins (1 ou 2) dans le village à l'aide de sifflet (une adaptation de la sonde électrique) suivant un calendrier régulier adopté par le lecteur (par exemple : tous les lundi à partir de 5heures du matin). Le suivi de la pluviométrie est réalisé à l'aide de pluviomètre paysan placé dans l'ensemble des villages d'intervention. La lecture et l'enregistrement des données pluviométrique se fait chaque jour de pluie. Les deux lecteurs du village s'organisent pour que l'un relève les données des puits et l'autre pour le pluviomètre. Le projet dans un souci de durabilité responsabilise entièrement les communautés pour le suivi de leur ressource. Le projet a contribué à la dotation en équipement de mesure (pluviomètre, sifflet, sonde) et de la formation, en combinaison de protection (blouson, botte, torche) pour la sécurité des lecteurs. En dehors de cela, aucune rémunération n'est offerte aux lecteurs.



*Photo 6 : Balima Karim prêt à mesurer la variation du puits témoins de Basbéd*



*Photo 5 : Sorgho Bila entrain d'enregistrer les données du pluviomètre de Basbéd*



## SUSTAINABLE SERVICES

### Community Managed Supplies

- **La présentation des données de suivi des ressources en eau pour la prise de décisions :** Les lecteurs communautaires procèdent à chaque fin de saison hivernale à la présentation des données pluviométriques recueillies et en fin de saison sèche la présentation du comportement des puits durant la saison. Ces données sont présentées sous forme de série de graphique (courbe de tendance de plusieurs années) afin d'avoir un aperçu visuel des tendances d'une année et d'une année à une autre. Ensemble les communautés tentent de comprendre et d'expliquer le lien entre la variation temporelle des pluies et les rendements agricoles enregistrés. Cela leur permet de tirer des leçons et de prévoir le comportement des ressources en eau souterraine au cours de la période à venir. Sur la base de ces analyses, les communautés sous l'autorité du chef de villages et d'autres leaders communautaires définissent les priorités en termes d'usage de l'eau et règlementent les comportements durant la saison. Depuis 2014, le projet soutien les 14 communautés pour la tenue de leurs assemblées générales.
- **La réalisation de forages et de puits :** le faible nombre de points d'eau constitue une source importante de vulnérabilité des communautés dans la mesure où l'insuffisance d'eau limite les initiatives économiques. Le projet en plus de l'appui au suivi des menaces, accompagne les communautés dans la réalisation et la réhabilitation de forage et de puits. Cela permet non seulement de réduire la vulnérabilité des communautés mais aussi de favoriser l'application des mesures identifiées par les communautés lors des assemblées générales. Le projet a permis la réalisation de 3 nouveaux forages, la réhabilitation de 3 anciens forages en mauvais état et la construction de 4 puits.



*Photo 7 : Nouveau forage réalisé dans le village de Sablogo*



*Photo 8 : Nouveau puits réalisé dans le village de Nabitenga*

- **Le suivi piézométrique et le renforcement des capacités de la direction régionale en charge de l'eau :** Le suivi piézométrique concerne la mesure du comportement de la nappe profonde à l'aide de Data logger. Ce suivi est réalisé dans des forages exploités par les communautés. La collecte des données est assurée trimestriellement par un agent de la direction régionale en charge de l'eau. Le projet a permis d'équiper 2 forages en plus des 3 forages qui sont suivis depuis 2011. Il a en outre permis de former 2 agents de la direction régionale sur le paramétrage, le chargement des données et l'interprétation des données des loggers.
- **La mise en place de plateformes de dialogue et d'apprentissage :** plusieurs plateformes sont prévues dans le cadre du projet afin de favoriser la concertation, le partage d'expérience et l'apprentissage. Ainsi, le groupe d'apprentissage du Burkina Faso (GAB) est une plateforme

## SUSTAINABLE SERVICES

### Community Managed Supplies

d'apprentissage que le projet appui et qui regroupe plusieurs types d'acteurs du secteur (les services techniques de l'Etat, les agences gouvernementaux, les organisations non gouvernementales, les instituts de recherche) au niveau national. Cette plateforme offre l'opportunité d'échanger et de tisser des relations de travail avec d'autres acteurs afin d'améliorer les résultats du projet. Le GAB est à sa 9<sup>e</sup> session depuis sa mise en place en 2011 et s'est doté d'une plateforme virtuelle de partage (<http://gap.rlcwrm.vba-volta.org>). Au niveau régional le processus de mise en place de l'observatoire du sous-bassin de la Nouhao est en cours. Il s'agit d'une plateforme d'échanges, de partage de connaissances et d'informations pour une meilleure prise de décision sur la planification et la gestion de la ressource dans le sous-bassin. Il regroupe au niveau régional les acteurs étatiques, les collectivités territoriales, les ONG/associations et les communautés. Cette plateforme entend s'appuyer sur les actions du projet pour piloter un système d'information sur l'eau au profit des communautés du sous bassin.

- **L'élaboration des plans de prévention contre les catastrophes :** il s'agit d'accompagner les communautés à définir les mesures pour renforcer leurs résiliences, pour prévenir les catastrophes, pour gérer les catastrophes et pour le relèvement en cas de catastrophe. L'équipe du projet a été formée dans le cadre de cet appui. Les plans seront élaborés au cours du 4<sup>e</sup> trimestre 2016. En fonction des actions définies dans les plans, le projet apportera un appui à la mise en œuvre et un accompagnement pour le marketing de ces plans.

### Résultats principaux et leçons tirées

#### Les principaux acquis du projet en une année de mise en œuvre

- Le projet a contribué à l'amélioration de l'accès à l'eau à travers la réalisation de trois (03) nouveaux forages dans les communautés de Basbédo, Nabitenga et Sablogo, la réhabilitation de trois (03) anciens forages dans les communautés de Basbédo et Malenga-Yarcé et la construction de quatre (04) puits dans les communautés de Noctenga, Nabitenga, Loungo et Pissiongo. Des comités de gestion ont été mis en place et formés au niveau des forages afin d'assurer leur durabilité. Ces différents points d'eau facilitent la planification de la ressource pour ces communautés. L'évaluation annuelle du projet a révélé que certaines communautés ont pris des mesures en interdisant certaines activités au niveau des forages notamment la confection de brique et les pépinières. Ces activités ont été orientées vers les puits pendant que les forages ont été consacrés aux besoins domestiques et à l'abreuvement des animaux. Ces actions du projet ont contribué à réduire les conflits d'usage comme le témoigne Mariam GOUMBRE, ménagère du village de Pissiongo « *Maintenant nous avons une meilleure vie dans le village. Les petites bagarres entre nous les femmes et les bergers sont devenues très rares. Avant il ne se passait un jour sans que l'une d'entre nous ne se bagarre avec les éleveurs qui viennent abreuver leur troupeau. C'était vraiment pénible..... Je me souviens d'une dispute qui a dégénéré en bagarre entre un groupe de femmes et des bergers autour du forage. Cette bagarre a occasionné 3 blessés et plongé tout le village dans un profond inconfort.....Depuis que nous avons instauré les horaires pour les différents usages, nous ne vivons plus ces genres de conflits dans le village. Les femmes peuvent maintenant s'approvisionner en eau pour leur foyer le matin et le soir sans soucier d'être dérangé par les troupeaux* ».
- Le projet a permis de doter les communautés de compétences humaines capables d'interpréter les tendances saisonnières et la dynamique de leur ressource en eau. En effet, les lecteurs constituent aujourd'hui des personnes de référence dans leur village pour donner des informations sur les hauteurs d'eau enregistrées, prodiguer des conseils par rapport au calendrier cultural et au choix des semences. Les services techniques de l'agriculture collaborent avec ces lecteurs afin de disposer de données pluviométriques pour les besoins d'appui aux agriculteurs d'autres villages. Les témoignages recueillis lors de l'évaluation annuelle révèlent l'enthousiasme des communautés quant aux résultats de la démarche. Selon Paul SAWADOGO, Chef du village de Gaskom « *Le projet nous éclaire. Avec le pluviomètre, c'est sûr qu'au bout de trois ans, nous allons connaître avec exactitude quelle quantité d'eau est nécessaire dans le village par an pour avoir une bonne récolte et quelle semence adopter. Pour cela je suis très content. C'est quelque chose de très utile et indispensable pour la communauté qui est essentiellement constituée de cultivateur et d'éleveurs. Je suis particulièrement heureux que mon village ai bénéficié de ces actions*».

## SUSTAINABLE SERVICES

### Community Managed Supplies

- L'existence d'une base de données au niveau des communautés, des services techniques régionaux et auprès de WaterAid qui permet de suivre, d'interpréter et d'alerter si nécessaire. En effet, malgré que les données ne satisfassent pas à toute la rigueur scientifique, celles-ci permettent tout de même de visualiser les tendances globales de la dynamique des eaux souterraines et de la pluviométrie. Ainsi, si un phénomène exceptionnel survient, les données peuvent le révéler et permettre des investigations plus poussées ou prendre des mesures conservatoires. En améliorant le maillage, en poursuivant l'assurance qualité et en mettant la régularité des relevés, le pays peut combler le déficit de données pluviométriques et souterraines nécessaires à une planification et gestion par bassin hydrographique. Les graphiques suivants illustrent les tendances enregistrées par les lecteurs et par la direction régionale en charge de l'eau.

**GRAPHIQUE 1: Dynamique des puits temoins dans le village de Basbedo/ sources des données: lecteurs**

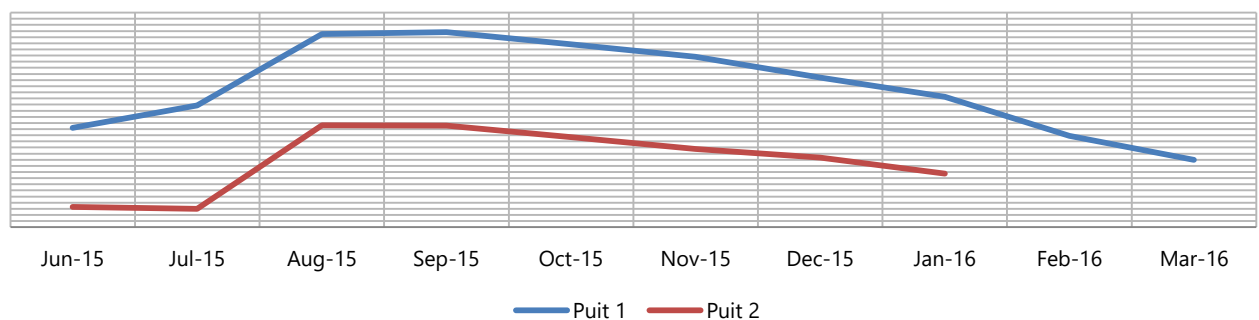

**GRAPHIQUE 2 : Hauteur de pluie enregistré de 2012 à 2015 dans le village de Basbedo/ Sources des données lecteurs**

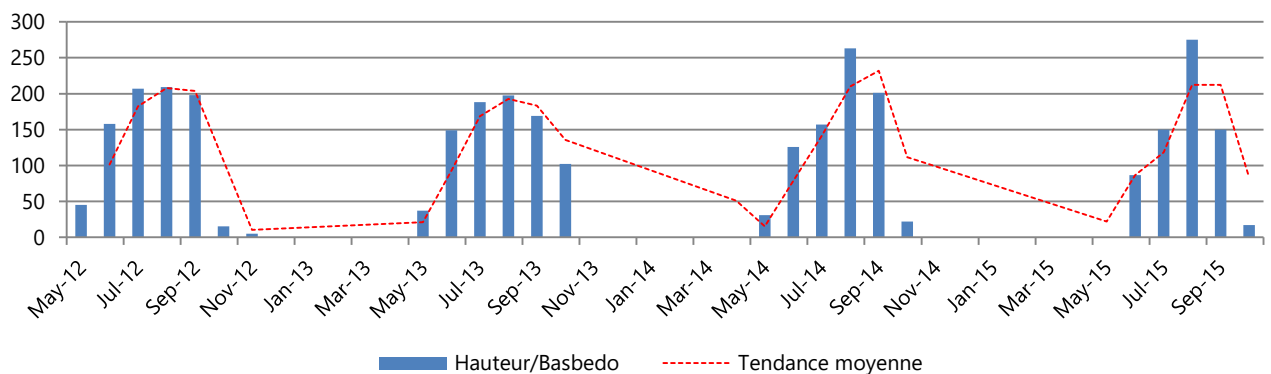

## SUSTAINABLE SERVICES

### Community Managed Supplies

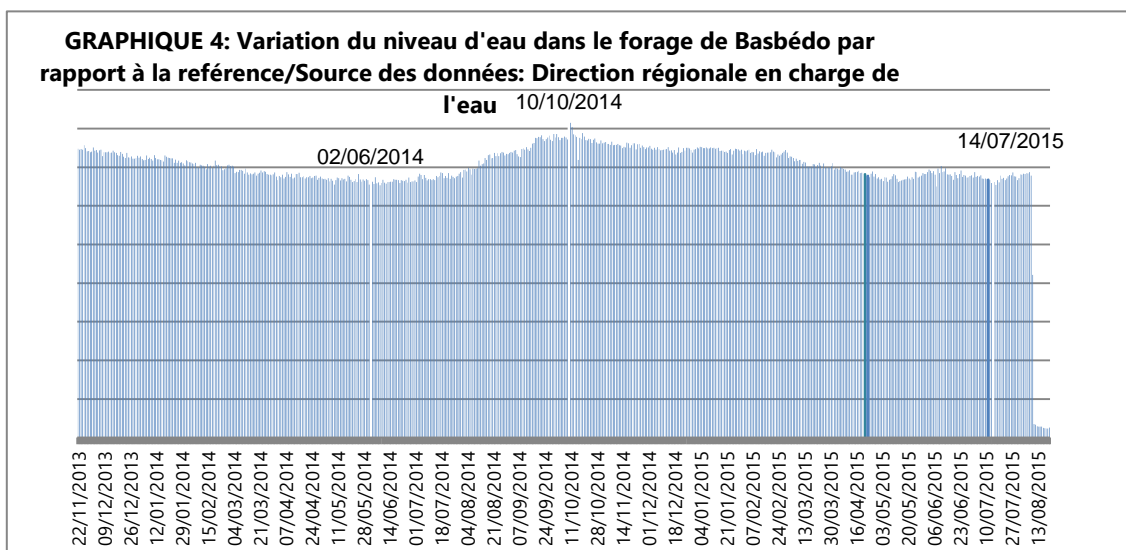
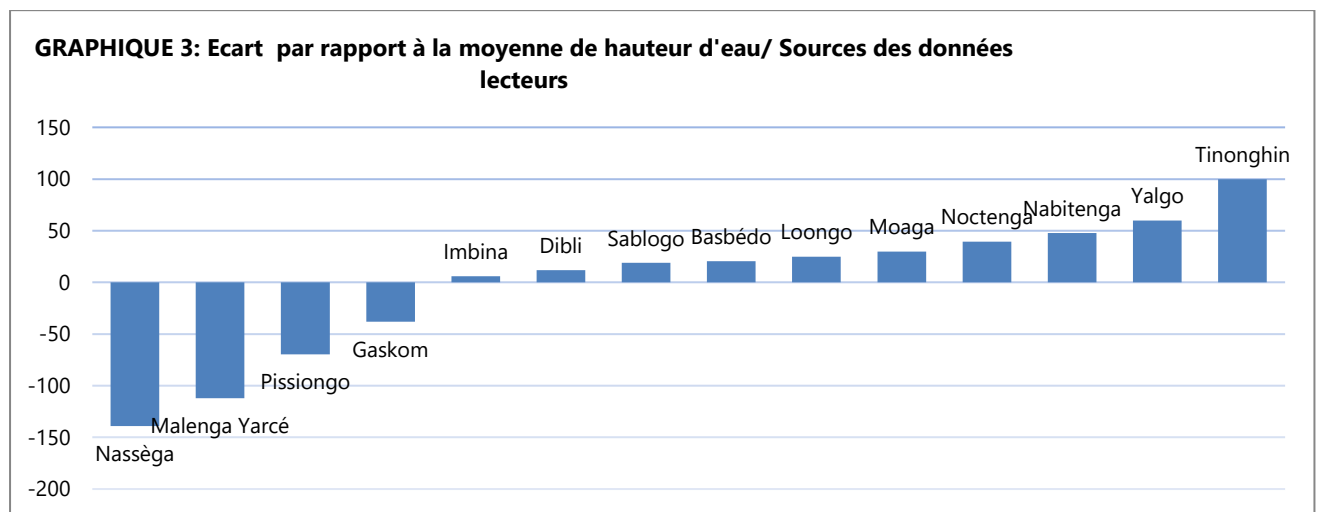

### Les principales leçons

Les principales leçons tirées à l'issu de la revue annuelle 2015 du projet sont les suivantes :

- la démarche du projet, en permettant l'interaction entre les communautés villageoises, les autorités communales, les services techniques au niveau central et régional et l'ONG de mise en œuvre, favorise une convergence de ces différents niveaux et renforce l'apprentissage ;
- l'approche sécurisation des ressources en eau responsabilise et valorise les ressources endogènes. De ce fait, les communautés sont fières des résultats obtenus et se reconnaissent auteurs des succès ;
- le renforcement des capacités des communautés est un facteur déterminant de succès : l'amélioration des capacités des communautés à analyser les problèmes, à rechercher les solutions, à initier, planifier et mettre en œuvre des actions de prévention des effets des catastrophes naturelles favorise une expertise locale disponible et accessible aux populations. Les lecteurs communautaires constituent aujourd'hui des personnes de référence dans leur localité pour l'appui conseil sur la dynamique de la nappe souterraine, les périodes de semis et la prévision des crises liées à l'eau ;
- les communautés locales comprennent aujourd'hui que devant un problème de développement local, il faut se réunir pour rechercher ensemble les causes et identifier les différentes solutions possibles. Les multiples initiatives prises pour la réglementation des heures d'usages au niveau des points d'eau, la répartition des points d'eau par usage et l'édiction de règles et de comportement pour la durabilité et l'hygiène au niveau des points d'eau sont la preuve de l'émergence d'une dynamique collective de gestion des ressources en eau.

## SUSTAINABLE SERVICES

### Community Managed Supplies

#### Conclusions et Recommandations

L'approche de sécurisation des ressources en eau en milieu rural développé et mise en œuvre par WaterAid Burkina est assez simple et répond aux besoins et à la capacité des communautés. Celles-ci voient leur compétence renforcé et peuvent constituer une opportunité pour la recherche scientifique. Le modèle de WaterAid se révèle un puissant accélérateur de la prise de conscience des communautés sur les effets du changement climatique sur les ressources en eau. Le modèle participe au renforcement de la cohésion sociale en se basant sur la gestion concertée des ressources en eau.

Les recommandations pertinentes issues de la revue annuelle du projet et de la session de partage du groupe d'apprentissage du Burkina sont les suivantes :

- développer le suivi-évaluation communautaire du projet;
- renforcer les capacités des techniciens communaux sur la collecte et l'interprétation de données à l'aide de data loggers afin d'accroître leur participation à la gestion des ressources en eau ;
- associer à la mise en œuvre de l'initiative les chercheurs du domaine de l'eau et du changement climatique ;
- prendre en compte les eaux de surface (barrage, cours d'eau) dans le suivi des ressources en eau afin de d'intégrer l'aspect « prévision des inondations ».

#### Mentions

*WaterAid Burkina Faso*

*WaterAid America*

*L'Association Dakupa*

*Les Communes de Tenkodogo et de Lalgaye*

*La Direction Régionale de l'Eau et de l'Assainissement (DREA)/Centre-Est*

*Le Centre Régional d'Apprentissage sur la Gestion des Ressources en Eau (RLC/WRM)*

#### Références

*WaterAid Burkina (2015) 'Revue annuelle du projet Réduction des risques de catastrophes' Rapport final*

*RLC-WRM, WaterAid (2014), 'Document de projet Réduction des Risque de Catastrophe' version française*

*RLC-WRM, WaterAid Burkina (2013)'Capitalisation de l'approche Community Base Water Resource Management (CBWRM)' Rapport final*

*RLC-WRM, WaterAid (2013) 'Renforcement des services d'AEPHA et de la résilience des populations à travers la gestion communautaire des ressources en eau' Document de Synthèse.*

## SUSTAINABLE SERVICES

### Community Managed Supplies

# Sharing Experiences in Implementing a Community Based Water Supply Schemes in Post conflict Areas in Sri Lanka

Type: Short Paper

Author: *I.V.W.Ediriveera*, Assistant General Manager, National Water Supply and Drainage Board, Sri Lanka, [vkediri@hotmail.com](mailto:vkediri@hotmail.com), +94-777222083

### Abstract/Summary

The Government of Sri Lanka was provided with financial assistance from AusAid (Australian Agency for International Development) to implement a community driven project focused on provision of water supply, sanitation and hygiene (WASH) promotion in areas affected by the protracted conflict that lasted nearly three decades. The areas that were mainly affected was the Northern and the Eastern parts of Sri Lanka, where following the conclusion of the confrontations in 2009, the gradual resettlement displaced persons was taking place. The implementing agency was the National Water Supply and Drainage Board (NWSDB) of the Government of Sri Lanka (functioning under the Ministry of Water Supply) the lead organisation for pipe borne water supply in the country. The project known as the North East Province Water and Sanitation Project (NEP-WASH) was a pilot project administered by the World Bank and was to be completed within a period of two years (2011-2012). The project sought to merge infrastructure development with hygiene behavioural change in communities affected by conflict. The project was a major success story not only in terms of achieving its primary development objectives provision of water supply, sanitation and hygiene education, but also by mainstreaming the concepts of participatory development, gender equity, social inclusion and integration. The experience gained by the project (which was implemented in ten communities) was the basis for the design of the Rural Water Supply Component of a wider World Bank financed Water Supply and Sanitation Improvement Project currently being implemented. This paper discusses the experience in conducting community WASH projects in the specific context of post-conflict resettlement in Sri Lanka.

### Introduction

Sustained access to safe drinking water and improved sanitation facilities has been a serious problem for communities in isolated rural areas of the country. Despite significant achievements in coverage at the national level, the numbers drop dramatically for rural areas particularly in the provision of pipe borne water supply. Often these communities represent the poorest and the most marginalized and vulnerable households in the country, and the added burden of the opportunity cost of fetching water is something these communities could ill afford.

Provision of infrastructure alone was not going to be sufficient to ensure the desired behavioural changes due the affected citizens not having exposure to normal communal living because of living in a war situation that entrenched unsanitary practices.

The beneficiary communities were resettled after a long period of internal displacement and showed limited characteristics of belonging to a community. Many of them had left their native places as children and lived in temporary shelters throughout their lives. Villagers, some of whom now heads of families, have not lived with one another as members of the same community although they hailed from the same village before the conflict. Many of the young male adults had lost their lives in the conflict and the older people who had knowledge of their ancestry have passed on. This resulted in the very challenging task of

## SUSTAINABLE SERVICES

### Community Managed Supplies

implementing community driven development project in communities that had not only being traumatized, but highly fragmented.

The villagers were in a state of desperation. Faced with a range of complex and intractable challenges due to the prolonged conflict that resulted in underinvestment in essential social and physical infrastructure in the area. People had little opportunity to engage in meaningful livelihood activities. The local and international NGOs operating in the area provided free offerings for their sustenance; and the people were getting used to receiving handouts and not engaging in productive work. The situation had escalated to a state where they were displaying signs suffering from a dependency syndrome.

The villagers gave WASH activities little priority. During the initial stages of project implementation, the NWSDB project team had limited access to the communities due to the presence of land mines and severely damaged access roads, which were overgrown with shrubs. Access to routine services, facilities and supplied was difficult. The houses that were damaged were either being reconstructed or had been abandoned.

### Context, aims and activities undertaken

The project faced many challenges in the community mobilization process as different ethnic and religious communities showed different attitudes and cultural behaviour towards community activities and the priorities of WASH. Even within the members of the same community, they displayed differences in attitudes and interest. They carried the remains of different cultural and contextual settings that prevailed during their displacement; that included living in other districts, provinces or even countries.

The Project Team had to approach each and every community and their subsections with a strategy unique to each engagement. Suitable community facilitators were mobilized who had first hand understanding of these communities; often educated young persons from the community who have had some opportunity to live a relatively “normal” life during the conflict and returned back to their original villages. The Project Team believed that if somebody from their own community who well understood their state of mind was to be the facilitator, then the mobilization process would be more real. Therefore, the strategy was to involve these young adults and older school-going children within the community to approach their elders and to begin to instil a sense of hope. As the messages were being relayed through their own people, the elders began to warm up to the changing social dynamics.

According to Herald Vervoorn - ZOA Refugee Care, 2003-2006, Most families do not even have a private well. Due to the conflict and displacements toilets were damaged or families have never been able to build a toilet, while they had no income and there was no cement. In certain districts only a small percentage of the population has a real toilet, the others have to use a pit, corner of their compound or go to the sea or jungle.

### Main Challenges and Concerns Addressed:

*Lack of knowledge regarding the connection between water and health:* Although lack of water is generally experienced by people living in water-scarce environments, the connection between water and health outcomes is not well understood by all. Often reference is made to the past without recognizing the changes that have taken place in the interim. The perception that the forefathers used the same source of water is taken for granted for continuing with the same sources and practices. Poor people are often victims of WASH related diseases and suffer economic and social losses as a result. Where “old habits die hard”, concerted efforts for information, education and communication is capable of making and sustaining the desired behavioural changes. The NEP-WASH pilot project conducted awareness programmes for all sections of the communities with targeted programmes identifying the differing needs of the women and the girl child as well as men and boys.

## SUSTAINABLE SERVICES

### Community Managed Supplies

*Community participation:* Community driven development approach lay emphasis on community participation from setting objectives, planning, mobilization, implementation, monitoring and evaluation and subsequent operation and maintenance. In the context of resettlement where people are busy with establishing their livelihoods or even the resettlement process still ongoing, it is a challenge to obtain community participation as normally expected elsewhere. In many cases the people are more concerned with establishing the boundaries of their dwellings that is difficult to identify due to the long period of abandonment. In some communities the old leadership is non-existent due to migration or death during the conflict. The dispersed families who lived among their relatives have not only have new additions to their families who are strangers to normal way of life, but also have been exposed to extreme experiences of an armed conflict. In most cases, several village communities have to depend on one water source for a new water supply scheme. In such situations, organizing people into community action is fraught with extraordinary difficulties.

*Gender sensitivity and vulnerability:* Women play a significant role in WASH related activities. Fetching water for household activities are socially perceived as the role of women or a girl-child. However, due to various socio-cultural reasons women’s concerns were not adequately heard and addressed. Only limited opportunities exist in the decision making process on matters that affect women the most. The situation is hard for the poorer of the poor, in particular, female heads of households.

Under the NEP-WASH Pilot Project, women responded positively to the opportunities afforded to them for decision making by assuming positions of responsibility within Water User Association (WUA). They functioned not only in the WUA management committees, but also as small group leaders in their respective neighbourhoods. However, despite cultural barriers standing in the way of women taking leadership; the mandatory requirements in the formation of the committees within the WUA helped them to assume a considerable role and their voices were heard.

*Equity:* The pilot project was implemented in the conflict affected villages consisting all major ethnic groups. This served to address the perception that NGO/international aid agencies work only for certain areas and for certain ethnic groups and exclude other communities that are were also conflict affected.

*Social harmony:* The project contributed positively to build social harmony. It brought the relatively isolated ethnic communities in the north and the east that did not have exposure to the outside world for at least one generation in contact with members of the other ethnic communities. New and valued relationships developed between the beneficiary communities on one part and the government officers, the contractor’s skilled worker force on the other. The beneficiaries who who provided unskilled labour to the contractors learned new skills and gained knowledge in addition to gaining much needed income. After the construction activities were over some people continued to work under the same contractor at other construction sites away from their own village.

At the community level, people of different villages got organized into one water service community. Exposure visits were made to well established community managed systems elsewhere and the participation in training programmes on operation and maintenance also contributed to harmonizing the relationships among different ethnic groups as well as the sub groups within the village. Traditional institutions that are important agents of social integration were rejuvenated in the process of project implementation. In some places the traditional religious institutions provided land for the project. There were instances of individuals offering private property for the project although the majority of the beneficiaries belong to other ethnic groups and religious faiths.

### Main results and lessons learnt

The three focus areas of the project were to provide water supply, sanitation and hygiene education to conflict affected communities. The strategy was for the implementing agency to outsource the construction activities, to provide contractors and the technical supervision to be done by the national



## **SUSTAINABLE SERVICES**

### **Community Managed Supplies**

authorities. The participation of the beneficiary community through the WUAs formed for the purpose. The community water supply systems thus constructed serves a population of 8,359 in 2,059 households of which 354 households are female-headed. By way of 10 water supply subprojects, these communities are provided with 60-80lpcd; in most cases 24-hour supply. In addition, approximately 500 water sealed latrines were constructed to ensure total sanitation – in the project areas.

The implementing agency (NWSDB) created an enabling environment for the WUA in terms of capacity enhancement of the key officials and the executive committee members in respect of the various project activities and the operation and management functions of the water supply services following the subsequent handing over of the system. Institutional linkages were formed through the formal registration of the WUAs with the local government authorities and the divisional administrative system. Bank accounts were opened with the State Banks in the name of the WUAs to facilitate the activities initiated. The mechanism created at the national level – the Project Management Unit (PMU) – encouraged direct communication between the community and the NWSDB.

In respect of these activities the WUAs played a significant role in terms of assisting in the organization of all relevant activities. With respect to the water supply scheme they provided indigenous knowledge to help identification of potential water sources, collected the basic information for needs assessment and provided inputs and observations for planning. Thereafter, they assisted in the process of implementation including community mobilization for the purchase of water meters from suppliers through tender procedures and obtaining private land owners’ consent for pipe laying and land for construction sites through dialogue.

The projects were successful in mobilizing communities to assume responsibility for planning, implementing and managing both water supply and sanitation infrastructure. However, training and consolidation of community organizations takes a sustained effort to be successful in the longer term as WUAs need time to develop a full commitment and acquire experience to manage infrastructure. Community participation should begin as soon as subproject selection is completed. Identifying and engaging the community leaders and identifying O&M staff that would eventually manage the scheme early in the process allows for more time to better ready the community to confidently takeover the scheme once completed.

WUAs were often found to be reluctant to increase tariff resulting in them being unable to generate adequate revenues to properly account for O&M of the system; and particularly to save for future replacement costs. Sustained training on tariff design book keeping and revenue management to make tariffs sustainable and equitable needs to be done in addition to introducing a mandatory tariff structure indexed to key related inflation elements.

### **Conclusions and Recommendations**

An important part of the strategy was the creation of a community organization to take charge of operation and management as well as partnering in the implementation. The experience shows the viability of public institutions in creating and supporting community level organizations. It also had an impact on the officers, the local political authorities as well as the contractors in terms of being supportive towards community management.

Outsourcing the construction work resulted in social harmony. The contractors were outsiders who had different cultural backgrounds. However, they were still welcome by the beneficiary communities. The contractors used the local labour and in the process of construction cultivated good relationships with each other. The local people also learned construction technology. After the construction work was complete some local labour chose to leave the village to work under the contractor at far away sites.

The project provided the community with opportunities for assuming leadership. Females took up leadership positions in the WUAs and in small groups. They were inspired by the mode of operation of

## SUSTAINABLE SERVICES

### Community Managed Supplies

the project and the prospects for enhanced welfare of their children and the establishment of home gardens that will enable them to prepare healthy food and earn an additional income. The women in particular, especially the female heads of households were reassured that this project gave them personal security and dignity.

"After four years of operation, our observations are that all of the 10 schemes are still in operation with communities handling their own maintenance.

### Acknowledgements

I am highly indebted to Task Team of the World Bank, specially Mr. Samantha Wijesundara- Water and Sanitation Specialist and officers of the AusAid for their guidance and support in implementing the NEP-WASH project successfully; and subsequently for sharing information to write this paper. I would also like to express my gratitude towards my colleagues in the National Water Supply and Drainage Board for their kind co-operation and constant encouragement, which helped me enormously to complete the project successfully.

### References

- (1) 2014, NEPWASH project completion report.  
I interviewed the Water and Sanitation Specialist of the World Bank Colombo Eng. Samantha Wijesundera who confirmed the smooth functioning of the Kiliveddy and Navatcholai Schemes and the full beneficiary satisfaction and that Wijesundera stated that "to his knowledge all schemes constructed under the project function in the same manner".
- (2) *Herald Vervoorn - ZOA Refugee Care, 2003-2006* ([http://transcurrents.com/tc/2009/06/post\\_375.html](http://transcurrents.com/tc/2009/06/post_375.html))
- (3) Implementation Status & Results ,Sri Lanka-LK North and East Pilot WASH for Post-Conflict Resettle (NEP WASH) (P126697)

## SUSTAINABLE SERVICES

### Community Managed Supplies

# Making systems work: Local government approaches to improving WASH service delivery in Malawi

Type: Short Paper

**Authors:** Sydney Byrns, Program Director- WASH Catalysts, Malawi, [sydneybyrns@ewb.ca](mailto:sydneybyrns@ewb.ca), +265 991 755 901; Genevieve Hughes

## Abstract/Summary

District government water offices in Malawi face significant financial barriers to delivering WASH services at scale. Government budgets are constrained, and the few resources that reach the district level are often under-utilized. This paper sheds light on some of the key systemic barriers to improved WASH service delivery in Malawi and shares examples from district government water offices of innovations developed to sustain service delivery with limited resources. Common approaches that have emerged can be clustered into three main categories: designing systems within district government resource constraints; supporting community structures in management roles; and building strong district teams. Insights on these innovative approaches have proven useful for both district level government to manage in a resource constrained context, as well as for NGOs implementing projects that integrate aspects of institutional sustainability.

## Introduction

Despite years of investment in water provision through installation of shallow wells, taps, and boreholes, national estimates indicate that approximately 27% of rural water points are non-functional in Malawi (Government of Malawi, 2016). This functionality gap can be largely attributed to a lack of timely operation and maintenance of facilities. In the early 1990s, decentralisation policy stated that the responsibility for ensuring rural water points are maintained would lie with the district government water offices (Government of Malawi, 1998). However, the current average monthly operational budget of district government water offices is the equivalent of about \$400 USD (Government of Malawi, 2015), which can be hardly enough to cover office rental, utilities, and vehicle maintenance, leaving very few funds for fuel or other activity costs. A community based management (CBM) approach was adopted in an attempt to mitigate many of the resource challenges faced by government in providing maintenance services to rural areas. This approach has faced many challenges, including low functionality of water point committees (Chowns, 2014).

While recognizing that a lack of resources is indeed a major restricting factor in the level of services that district government offices are able to provide, it is often used as a scape goat for not making concerted efforts to improve service delivery. On top of purely financial limitations, there are a number of key systemic challenges that face district government water offices that are contributing to the continued plague of low functionality and failing CBM systems. These include, but are not limited to:

- prioritization of project implementation activities over routine management activities;
- systems that are not set up within resource constraints;
- poor support and mentorship of community-based management structures;
- poor coordination of NGO approaches at district level;
- lack of teamwork within water offices; and
- a pre-occupation with technical skills development that overlooks building important management capacities of permanent stakeholders.

This paper will describe some of the approaches that various district government water offices have taken

## SUSTAINABLE SERVICES

### Community Managed Supplies

to address these systemic challenges in the effort to improve WASH service delivery in Malawi.

#### Context, aims and activities undertaken

Since 2008, WASH Catalysts, a venture of Engineers Without Borders Canada, has been working to shift the WASH sector in Malawi from a projectized to a service delivery approach. Our mandate has been to strengthen the country systems that create the enabling environment for improved WASH service delivery, working primarily with national and district level government as the primary duty bearers in the sector. As a result, our staff have collectively spent several years embedded in district government water offices building an understanding of the main challenges and emerging positive approaches to improving WASH service delivery in rural areas. Current areas of focus include institutionalizing a Water Sector Wide Approach; advocating for increased devolution of funds to district government water offices; improving project design for institutional sustainability; and developing a network of district government innovators for low-cost approaches to service delivery.

Over the last two years, we have been running a unique fellowship program that encourages financially stretched district government water offices to make creative use of their existing resources to fulfill important routine activities that support operation and maintenance of community water points. As part of the fellowship program, district government water offices are invited to apply to WASH Catalysts with innovative approaches they have for improving rural WASH service delivery in their areas.

The overarching design constraint for submissions to this fellowship is that the idea must be implemented within the existing recurring government budget of their offices. Once accepted into the program, WASH Catalysts provides thought partnership to further develop the innovative idea, as well as an embedded staff member in the water office for a period of 4 months to support the pilot of the proposed approach. We do not provide any financial support to get the idea off the ground. After the initial pilot, we periodically bring together all the districts that are part of the program to share and learn from each other, and a WASH Catalysts staff member will travel to the district to provide follow up support to overcome any new implementation barriers.

#### Main results and lessons learnt

The implementation of the fellowship program has encouraged district government offices to generate practical solutions for improving rural WASH service delivery using existing resources. Since the inception of the fellowship program in 2014, fourteen of the twenty-eight districts in Malawi have been inducted into the network. There have been quarterly peer-to-peer learning forums for fellows to share successes and challenges faced, as well as building the relationships between fellow districts. A number of promising approaches have emerged in response to the key systemic challenges that are not only useful for district government water offices, but a number of NGO projects have found these approaches helpful when considering designing their projects with better sustainability. Many of the emerging approaches relate to designing systems within resource constraints, supporting community structures in management roles, as well as building stronger teams. Some examples of approaches are highlighted below:

##### 1) Designing systems within district government resource constraints

The management of any system in the absence of a project will have to stand on the budget of the government, no matter how meagre this budget may be. To fit within resource constraints, many districts have come up with approaches to budget for alternative lower-cost materials and methods.

- In Nkhata Bay district, the fuel budget for extension staff allowed only 8 trips to the field in a month but the district had over 40 hand pump mechanics to meet with in the same time period. They re-designed their system to meet mechanics in groups and to use public transportation when possible rather than buying fuel for every field trip.

## SUSTAINABLE SERVICES

### Community Managed Supplies

- In Nkhotakota district, the water office has started buying cheap school exercise notebooks to capture routine monitoring of water point functionality instead of printing costly data collection forms. They copy the questions over from the previous page each month and then fill in the updated data.

#### 2) Supporting community structures in management roles

Resource constrained systems naturally encourage community based management approaches as a theoretically more manageable system. However, strong monitoring and follow up support to community structures such as hand pump mechanics and water point committees is essential for this approach to be effective.

To better support hand pump mechanics, many offices have developed ways of keeping in regular communication with the mechanics, providing mentorship to overcome technical challenges or community conflicts, and raising awareness about the mechanics at community level.

- In Mzimba district, the water office prepares letters for the district Heads of churches to disseminate information about hand pump mechanics through their church communication lines. The letters include a flyer on the roles and responsibilities of the mechanics and their contact information.
- In Mulanje district, community police groups were identified as a means to distribute hand pump mechanic contact information and terms of service to communities, which can help to bolster the profile and trust of the mechanics in communities.

One of the challenges in supporting individual water point committees is that they are so numerous. In Malawi, a single district will have upwards of two thousand water points to monitor with only limited staff and resources. Working closely with these groups has been a useful way to extend the reach of the water office without having to travel to every single water user.

- In Machinga district, the office leveraged the 14 Area Development Committees as a network to increase the reach of the district government water office. The district negotiated a memorandum of understanding (MoU) with each Area Development Committee to have them act as liaisons between the district and hand pump mechanics and water point committees in their respective areas.
- In Nkhotakota district, Area Development Committees visit water point committees in their area monthly, facilitate water point repairs, mediate community water issues, and submit reports to the water office. The district government water office stays in regular contact with the Committees and provides technical support on an as-needed basis.

#### 3) Building strong district teams

When district government water office staff are brought into and share a common vision, it is easier for them to support each other in achieving individual outcomes. The implementation of WASH infrastructure often focuses on building the technical capacity of permanent stakeholders, or even contracting out these technical jobs, and avoids addressing the management and operations skills required to function as service authorities. Building non-technical skills of extension workers in facilitation, management, and conflict management through projects can improve community interactions.

- In Nkhata Bay district, extension staff submit pieces of the budget relevant to their work

## SUSTAINABLE SERVICES

### Community Managed Supplies

to the overall budget for the office. This helps increase ownership over the work and increases accuracy of the budget as extension staff have a good idea of resource requirements for fieldwork.

### Conclusions and Recommendations

Improving rural WASH service delivery by permanent institutions takes careful consideration of the resource envelope, planning for support of community structures, building strong district offices, and ensuring that NGO approaches are aligned with each other and with government. The simple innovations outlined in this paper are the result of a concerted effort by district staff to understand the implications of their office's role in sustaining services, and by taking steps to make their operations more efficient. With non-financial support, WASH Catalysts Malawi has been able to collaborate with district government water offices by offering thought partnership and change management process support. By working with as many district offices as possible, we will be able to build a growing majority of districts in Malawi who are thinking critically about how their office can effectively manage WASH service delivery using existing resources. It also shows NGOs and partners working at district level that there are tangible ways to improve sustainability of services through focusing on permanent institutions and the budget available to them in the long term.

### Acknowledgements

We gratefully acknowledge the opportunity to work with each of the District Water Offices mentioned in this paper, financial support from WaterAid Malawi which allowed much of this work to occur, and all the EWB Fellows and Junior Fellows who provided embedded support in these districts.

### References

- Chowns, E. (2014). *The political economy of community management: A study of factors influencing sustainability in Malawi's rural water supply sector*, Birmingham: University of Birmingham.
- Government of Malawi. (1998) *The Malawi National Decentralisation Policy*, Lilongwe: Ministry of Local Government and Rural Development.
- Government of Malawi. (2015) *Local Authorities Budget 2015-16*, Lilongwe: National Local Government Financing Committee.
- Government of Malawi. (2016). *Malawi Irrigation Water and Sanitation Sector Performance Report 2014/15*, Lilongwe: Ministry of Water Development and Irrigation.

## SUSTAINABLE SERVICES

### Community Managed Supplies

---

# Community management in Malawi: part of the sustainability problem, not the solution

---

Type: Short Paper

#### Author

Dr Ellie Chowns

From 01/06/16: Research Associate, Department of Geography, University of Sheffield, UK

Until 31/05/16: Teaching Fellow, International Development Department, University of Birmingham, UK

Email: [ellie.chowns@gmail.com](mailto:ellie.chowns@gmail.com)

Tel: 07950 714947

#### Abstract/Summary

This paper reports on a large-scale study of sustainability of rural and small town water supplies, covering 338 water points in four districts of Malawi, conducted in 2011-2012. The study tested ten determinants of sustainability, and critically examined the way that community management works in practice. Results show that technical factors such as installation quality are critically important for sustainability, while community management has only limited positive impact on functionality, and damaging side-effects. The findings seriously challenge the assumptions of efficiency and empowerment that underpin the community management model. The paper argues that true sustainability requires greater professionalisation of water point installation and management, and ongoing public investment in recurrent costs.

#### Introduction

Received wisdom suggests that community management is an important component of sustainable water supply in rural areas and small towns. Despite the growing shift in emphasis “from system to service” (Schouten and Moriarty 2003, Lockwood and Smits 2011) and on “community management plus”, in reality the basic community management model remains standard practice in Malawi, as in many other low-income countries: agencies install a water point, then hand over full responsibility to a committee of users. District Water Offices are supposed to provide post-construction support, but have limited capacity and receive very little funding (Lockwood and Kang 2012).

The arguments for community management derive from the broader literature on participation, and centre on two claims (Nelson and Wright 1995; Mohan and Stokke 2000). First, that it is efficient: users know immediately when a breakdown has occurred, have a clear interest in fixing it, and (thanks to initial training and regular savings) have both the necessary skills and the money readily available. Second, that it is empowering: users gain new skills and capacities for collective action via the introduced institution of the democratically-elected, gender-balanced, locally-accountable water point committee.

If community management indeed works, it should work well in Malawi, which enjoys various advantages: standardisation on the Afridev pump type; relatively high population density; good roads; accessible water table; absence of armed conflict. Access to safe water in Malawi has increased from 43% in 1990 to 90% in 2015 (WHO/JMP 2016), so it appears that the country is a success story. However, this paper suggests that fundamental problems with community management call into question the sustainability of these recent achievements.

## SUSTAINABLE SERVICES

### Community Managed Supplies

#### Context, aims and activities undertaken

This mixed methods study was conducted in four districts in Malawi in 2011-2012. Ninety-six water points in 24 VDCs (Village Development Committees, i.e. group villages) were randomly sampled for in-depth structured surveys, normally three per site: two with users and one with a ‘manager’, i.e. a member of the water point committee. A further 242 water points were surveyed in person, and basic data was collected from VDC members on the remaining 341 water points in the sampled VDCs, so the study covered 679 water points in total. Statistical testing was conducted on a nationwide database of 50,000 water points, as well as on the primary data, and quantitative and qualitative findings were triangulated. Further details on research design and methods are given in Chowns (2014, 2015).

The study addressed two key questions: 1) What are the key determinants of water point sustainability?; and 2) Does community management work? Part One of the study tested the influence of ten proximate determinants of sustainability, as outlined in Table 1. Part Two questioned the ‘efficiency’ and ‘empowerment’ assumptions implicit in the underlying community management model.

**Table 1. Determinants of water point sustainability: variables tested**

Design and installation variables	Post-construction variables
WPTYPE – Type of technology	MAINTFREQ – Frequency of maintenance
INSTQUAL – Quality of installation	SPARES – Accessibility of spare parts
USERS – User numbers	SKILLS – Availability of maintenance and repair skills
AGE – System age	FUNDS – Availability of funds for maintenance and repair
	SUPPORT – Availability of external support
	THEFT – Incidence of theft

#### Main results and lessons learnt

Findings regarding the determinants of sustainability are summarised briefly in Table 2; for more details see Chowns (2014). Two clear results emerge. First, technical factors (water point type and installation quality) are highly significant. In one sense, this is obvious: if an installation is poor quality in the first place, then no matter how good the committee, they will struggle to keep the water point working. Observations, surveys and interviews suggested that there is currently wide variation in installation quality, due to factors such as lack of technical skills, allocation of contracts on non-merit basis, and lack of supervision, inspection, or penalties for poor quality work. It is clear that paying more attention to technical quality of hardware would have a significant impact on sustainability.

Second, community management does not work nearly as well as it is supposed to. The core assumptions of the model are seriously called into question by the findings: preventive maintenance is almost never done; repairs are often slow and sub-standard; and committees are unable to collect and save funds. Committees are generally dormant or defunct, and often have to be reconstituted (amid conflict over finance) when a breakdown occurs. Users struggle to hold committees to account, since frequently, as one explained, “the committee is higher than the community”.



## SUSTAINABLE SERVICES

### Community Managed Supplies

**Table 2: Determinants of water point sustainability: summary of findings**

Variable	Influence	Key findings
WPTYPE	Very high	Boreholes have significantly higher functionality than piped systems (74% vs 27%). There is a very strong statistical association between water point type and functionality, driven mainly by the poor performance of taps. For boreholes, Afridev pumps are much better than solar pumps or Playpumps.
FUNDS	Very high	On average, actual savings are only 2% of expected savings. Median savings = MWK 1150, about \$4 at the time. There are frequent reports of poor financial management, and of community conflict over finance.
SKILLS	High	Most committees are non-functional. Few members are capable of repairing a water point: as one Chair said, “we don't maintain it because we don't know how the borehole works”. There are not enough Area Mechanics. Committees often wait for outsiders (MPs, NGOs) to fix their water points.
THEFT	High	Theft of parts is relatively common, and frequent in certain locations: reported at 15% of all WPs surveyed, with incidence exceeding 50% in 3 of the 24 VDCs. Water points that have experienced theft are more than 2.5 times more likely to be non-functional than the rest.
INSTQUAL	High	Government water points have much lower functionality (54%) than NGO water points (up to 97%). Respondents' comments included: “there is high functionality in Mangochi East because the technical part is just very good, the contractor is very good”; “the private sector has no quality control”; “most of these contractors are indeed crooked”.
MAINTFREQ	Medium	Preventative maintenance is almost never done. This is both a cause and a consequence of low skills. For high-quality water points, maintenance is rarely required.
SUPPORT	Medium	Little external support, follow up or monitoring is provided. When provided, it is associated with a small and statistically insignificant increase in functionality.
SPARES	Low	Few spares are held in stock by committees. But physical barriers to access are not very significant; questions of finance are more important. There is no statistical relationship between access to spares and functionality.
USERS	Low	Queuing time is a significant influence on whether people use safe water points; but there is no statistical relationship between user numbers and functionality.
AGE	Low	Age explains less than 1% of the variation in functionality.

These findings clearly call into question both the ‘efficiency’ and ‘empowerment’ claims for community management.

First, they show that community management is inefficient; its assumptions regarding maintenance, repairs, and savings are simply not borne out in practice. The ‘just in case’ financial management model based on regular advance payments into a collective fund is clearly unworkable; cash-strapped poor rural households are naturally unwilling to put money aside into such a fund when there are other more immediate calls on their purses, especially if they do not trust that the money will be safeguarded. Instead, when breakdowns occur, communities struggle to scrape together the funds required – a process that may take some time and cause some friction, but is clearly more financially rational for households.

Community management is also inefficient in another sense, since it requires the active involvement of many more people than necessary. In a VDC with, say, ten water points, it is superfluous and expensive to train ten committees of 10-12 people each, when all that is really needed may be one skilled Area Mechanic with a bike, a phone, and (crucially) an effective means of financing his or her work.

## SUSTAINABLE SERVICES

### Community Managed Supplies

Secondly, and perhaps even more worryingly, community management is disempowering. Users feel disempowered by their inability to hold the committee to account, while committee members feel disempowered by the difficulties they experience in fulfilling their functions. Committees, far from being new arenas in which ‘lowers’ can challenge ‘uppers’ (Chambers 1994), are adapted through a process of ‘institutional bricolage’ (Cleaver 2012) and instead tend to reproduce existing social inequalities. Conflicts over funds tend to undermine trust and erode social capital. Reliance on agencies and local ‘big men’ to fix problems (rather than calling on state support in the form of the District Water Office) tends to reinforce clientelism and erode the social contract.

Community management was originally conceived as a ‘software’ solution to a ‘hardware’ problem – a means to ensure that technical breakdowns were quickly fixed. But the findings of this study show that in many cases the software of the management model is less sustainable than the hardware of the water point itself.

### Conclusions and Recommendations

These problems of community management are not a case of ‘civil society failure’ (Mansuri and Rao 2013), but rather of donor failure and state failure. Community management remains the dominant model because it works better for agencies and governments than for communities themselves. It enables those with resources – donors and the state – to abdicate responsibility for long-term sustainability of water services, placing this burden instead on unpaid and unsupported users. This strategy is short-sighted, because it jeopardises the long-term sustainability of the capital investments made, and also simply unfair.

This paper therefore makes two key recommendations to agencies and governments involved in rural and small town water supplies:

- 1) First, do more to ensure high-quality installation in the first place. This could include improved inspection or auditing of installations, performance-linked installation contracts, and training of specialised personnel.
- 2) Second, and even more importantly, professionalise management, and fund recurrent costs directly – at least in the short to medium term. In practice, this means moving away from the committee model, and instead investing in training a smaller number of Area Mechanics and financing their work directly, via contracts with District Water Offices. This may even be cost-neutral, since there will be significant savings on water point committee training.

Of course, there is still an important role for community participation in water governance, including in decision-making about supply options, and in monitoring water point performance. But this should be emergent, not induced; and should be separated from ‘financial participation’. Communities are not required to bear the recurrent costs of other public services such as education or health, so why should they have to do so for water? We know that the public health benefits of safe water exceed household willingness-to-pay (Null et al 2012), and so user financing will be insufficient.

The challenge of sustainability is twofold: technical and financial. Currently, the community management financial model undermines technical sustainability, and thus is part of the problem, not the solution. The collective action on which it rests has high costs – in terms of money, time, co-ordination, and conflict – which fall unfairly on those with least resources. If we want to ensure ‘Water for Everyone’ we must admit the limitations of this model, and acknowledge that true sustainability requires ongoing public investment in recurrent costs.

### Acknowledgements

## SUSTAINABLE SERVICES

### Community Managed Supplies

I am deeply grateful to Yanjanani Chimpokosera for her fantastic research assistance; to all the research respondents in Malawi for their time and patience; and to the ESRC and IDD Birmingham for financial support.

#### References

- Chambers, R. (1994). *Paradigm shifts and the practice of participatory research and development*, Institute of Development Studies (UK).
- Chowns, E. (2014). *The political economy of community management: a study of factors influencing sustainability in Malawi's rural water supply sector*. Ph.D. thesis, University of Birmingham. <http://etheses.bham.ac.uk/5014/>
- Chowns, E. (2015). *Is Community Management an Efficient and Effective Model of Public Service Delivery? Lessons from the Rural Water Supply Sector in Malawi*. *Public Administration and Development* 35 (4): 263-276.
- Cleaver, F. (2012). *Development Through Bricolage: Rethinking Institutions for Natural Resource Management*. London, Routledge.
- Nelson, N. and S. Wright (1995). *Power and Participatory Development: Theory and Practice*, Intermediate Technology Publications.
- Null, C., M. Kremer, E. Miguel, J. G. Hombrados, R. Meeks and A. P. Zwane (2012). *Willingness to pay for cleaner water in less developed countries: Systematic review of experimental evidence*. *Systematic Review* 006. London, 3ie: International Initiative for Impact Evaluation.
- Lockwood, H. and M. Kang (2012). *Closing the gap: WASH sector devolution and decentralisation in Malawi*. Triple-S Working Paper 2. The Hague, The Netherlands, Triple-S / IRC International Water and Sanitation Centre.
- Lockwood, H. and S. Smits (2011). *Supporting Rural Water Supply: Moving towards a Service Delivery Approach*. Rugby, Practical Action Publishing.
- Mansuri, G. and V. Rao (2013). *Localizing Development: Does Participation Work?* World Bank Policy Research Report. Washington, D.C., The World Bank.
- Schouten, T. and P. Moriarty (2003). *Community Water, Community Management: From System to Service in Rural Areas*. Rugby, Practical Action Publishing.
- WHO/JMP (2016). *Data and estimates: tables*. <http://www.wssinfo.org/data-estimates/tables/>. Accessed 5 May 2016.

## ACCELERATING SELF SUPPLY

Progress in accelerating Self-supply

### 3.4 ACCELERATING SELF SUPPLY

#### 3.4.1 Progress in accelerating Self-supply

---

## Towards 2030 - Trends in rural water supply and the essential inclusion of Self-supply to achieve SDG targets

---

Type: Long Paper

**Authors** *Sally Sutton, SWL Consultants, UK, [sally@ssutton.fsbusiness.co.uk](mailto:sally@ssutton.fsbusiness.co.uk), Tel +441743351435*  
*André Olschewski, SKAT Foundation, Switzerland, [andre.olschewski@skat.ch](mailto:andre.olschewski@skat.ch), Tel +41 71 228 54 54*

#### **Abstract/Summary**

The number of people in Sub-Saharan Africa depending on unprotected water sources has not decreased over the past 25 years. Rates of progress in coverage over this period are far below those required to achieve universal access by 2030. Examination of some of the characteristics of the unserved population show major challenges to funding as well as to necessary rates of construction. Community water supply (CWS) as a sole solution is shown to be unable to solve the problem. The second half of the paper explores how self-financed water supplies are, or could be, filling the gaps public supplies leave. Enhancing support services in the public and private sectors to improve the safety and performance of Self-supply is shown, with examples, to be a cost-effective additional strategy, which can largely be integrated into existing services.

#### **Introduction**

In Sub-Saharan Africa (SSA) progress towards the MDG in rural water supply coverage has been significant (an overall increase of 22% points) but viewing it as percentages tends to hide specific trends which have major implications for reaching SDGs. These implications have been discussed in recent reviews with government in Zimbabwe, Zambia and Malawi under a UNICEF-funded project (SKAT/UNICEF 2015a,b and 2016), and are leading to greater government and donor consideration of alternative strategies to CWS to help reach 2030 targets. As a result this paper looks at the implications for sub-Saharan Africa as a whole, to raise awareness of the challenges to be faced and the necessity for broader strategies if all of the poorest and most vulnerable are to be enabled to access WASH support services.

#### **IMPLICATIONS OF COMMUNITY WATER SUPPLY IN UNIVERSAL ACCESS.**

##### **Trends in rural population growth and coverage**

Looking at progress to date, absolute values show that some 218 million more rural people in the region now have access to conventional improved supplies than in 1990. During the same period, the total rural population has grown by 244 million (WHO/UNICEF 2015). From 1990 to the present day the number without access to safe water has risen from 244 to 270 million. Whilst the number using surface water has declined the number using unprotected groundwater has increased. Just to provide universal access to those at present unserved by 2030 would require faster progress in the next 15 years than was achieved over the past 25 years.

In addition there is rural population growth (see Figure 1) to be considered. In the past 25 years the situation has been of ‘running hard in order even to stand still’ in terms of reducing the numbers of the unserved. Average annual growth in coverage has been consistently around 0.85-0.9% per annum since

## ACCELERATING SELF SUPPLY

### Progress in accelerating Self-supply

1995, and only briefly exceeded 1%. With rural-urban migration, the World Bank predicts a fall in rural growth rates from 1.7% to 1.5% per annum, but there will still be a 2030 rural population of some 796 million or 180 million more than 2015. If half of this growth is served by existing rural water supplies, there would still be a need to look for solutions for some 375 million more people over the next 15 years. This would require supplies for three times more people per year than was achieved during the last 25 years. In addition, for targets to be achieved at this rate, all existing supplies would need to be kept functioning or be replaced. Any move for the SDG of universal to be achieved using only the same strategies as before appears unlikely to succeed.

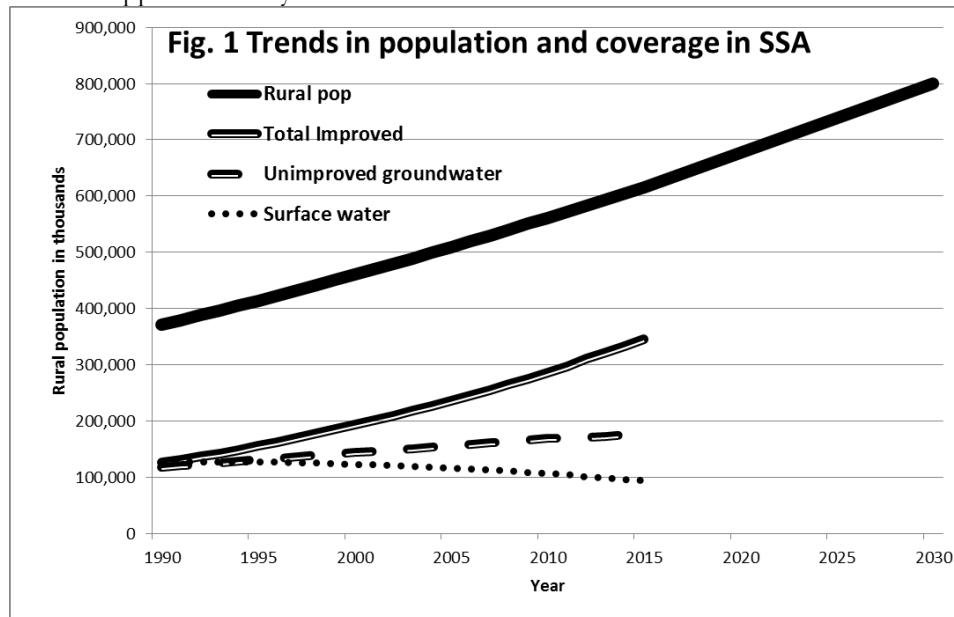

**Figure 1: Trends in population and coverage in Sub-Saharan Africa**  
 Population distribution and the future of service provision.

Per capita costs depend to a large degree on the number of people any one supply unit will serve. That may partly be indicated by population density. Populations are more easily and cost-effectively covered where density is highest.

Overall in SSA rural population densities are low (see Figure 2), averaging under 23/km<sup>2</sup>, or about four houses per km<sup>2</sup>. Only Rwanda and Burundi have more than 300/km<sup>2</sup> – equivalent to densities in India and Pakistan. Nigeria, Malawi and Uganda have reached some 100-150/km<sup>2</sup> but 42% of the mainland countries fall below 20/km<sup>2</sup> reflecting villages which are far apart and/or a tendency for scattered houses over a wide area. Both cases present difficult conditions in which to develop community water supplies (CWS) with good, affordable networks to support effective maintenance. The latter case especially presents difficulties in establishing a reasonable level of access to consumers since a single water point will have few houses within a convenient distance.

Table 1 shows a wide variation in the numbers of users per CWS, and of challenging situations to CWS which may affect future planning and budgeting, and functioning of supply.

Numbers served by handpumps in some countries are often still well above the design figure, which is likely to lead to queuing and breakdowns from over-use, both of which push people to use other sources temporarily or permanently. This feature tends to reflect under-provision in the larger communities first targeted, and/or levels of long-term breakdown. It highlights the fact that in addition to the ‘unserved’, many who are theoretically served are still waiting for adequate supply.

In other situations user numbers are already well below design populations. For example in Zambia, Milenge District (with an average population density of only 6.9/km<sup>2</sup>) giving priority to larger

## ACCELERATING SELF SUPPLY

### Progress in accelerating Self-supply

communities to achieve 70% coverage, already averages only 123 users per supply<sup>i</sup>. Low user numbers have negative implications for community ability to keep systems working.

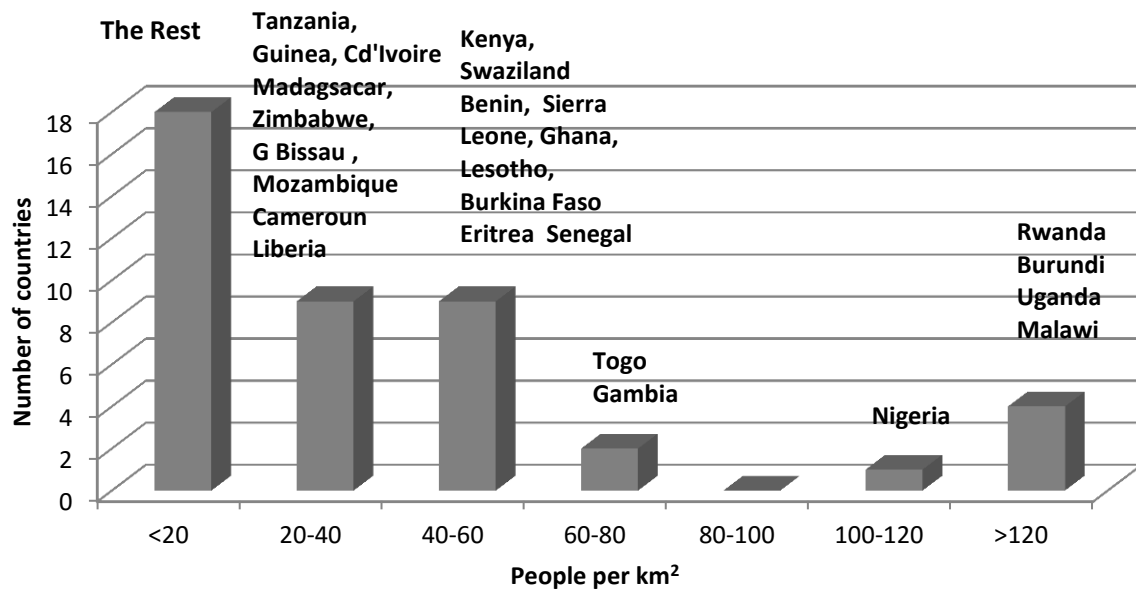

Figure 2 Population densities in rural Sub-Saharan Africa

The remaining unserved communities (indicated in Table 1 by data from Liberia, Malawi and Sierra Leone<sup>115</sup>), are much smaller than those so far served, and generally smaller than design populations for boreholes and handpumps. This is to be expected if larger communities are targeted first in cost-effective planning, but information on the actual situation is rarely available. Using district or national level data from Liberia, Sierra Leone, Malawi and Zambia from Central Statistics Offices or CLTS community surveys suggests (see Figure 3) that in these countries an average of around 30 % of the rural population presently live in communities smaller than 250 people and 15% in communities of less than 150. Thus overall, when coverage reaches 85%, communities remaining unserved will tend to be those However waterpoints need to be located in each community, and so although in coverage terms only 15% of people may live in smaller communities, many more than 15% of communities have less than 150 inhabitants.

There are big implications for the number of additional waterpoints if everyone is to be served. In terms of smaller communities, on average 63% of them in these four areas consist of less than 150 inhabitants (see Figure 3), and 20% less than 100. Liberia is taken as an example<sup>116</sup> as it is one of the very few countries for which served and unserved community size is available. Here in 2011 the average numbers using water points was 280 in some 3,780 communities. The average size of remaining unserved communities is only 114. When coverage reaches 80%, if the focus has continued to be on prioritising larger communities and so maximising early beneficiaries, remaining unserved communities will number over 10,000 and with one handpump in each community average number of users will be less than 60. Examples are few because information is scarce, but this example and data (see Figure 3) suggest that governments need to examine the characteristics of remaining unserved communities in different parts of their countries if budgets are to be sufficient to enable all marginalised people to have access to water

<sup>115</sup> Representing SSA countries with high, medium and low rural population densities

<sup>116</sup> Raw data for Liberia Waterpoint Atlas and 2008 CSO National Census compiled by Abdul Koroma Coordinator National Water, Sanitation and Hygiene Promotion Committee, and WP Inventory

## ACCELERATING SELF SUPPLY

### Progress in accelerating Self-supply

using existing strategies. Reaching the last unserved rural communities in the region with sustainable options will present an increasingly expensive challenge, as smaller and smaller groups of houses will remain unserved. The number of waterpoints needed to reach universal coverage in the region can be seen to verge on infinity. Their potential users also tend to be the ones with the weakest voice to speak to local government and often include the poorest households.

#### Cost implications for government and communities

The ‘mopping up’ the smaller and more remote rural populations in SSA will present a major funding challenge. The number of people to be covered per year to achieve universal access is estimated to be three times as many as the annual rate over the past 25 years, but the funds required will be several times more than that. Using the WashCost benchmark (WASHCost 2012) costing figures demonstrate the large effect of serving fewer people per CWS (see Figure 4) as smaller communities are reached. Actual costs may vary but the ratio of costs will remain essentially the same.

Table 1. Users per community waterpoint.

Country/ region	Number/ HP (served)	Average Unserved community size	Design population/WP	Information source
Ethiopia SNNPR	380		270/457	RiPPLE survey 2012/MoWR 2009
Sierra Leone Pujehun District	187	138	250	GOAL survey data 2012/ AfdB 2013
Malawi Kasungu	305	218	250	Kasungu WASH survey 2012
Zambia Milenge	123		250	Milenge DWASHE survey 2014
Zambia Southern	412		250	Wateraid (2008)
Liberia	280	114	250	Census and Waterpoint Atlas 2011
Mozambique	168		500	Wateraid survey 2008/UNICEF 2011

## ACCELERATING SELF SUPPLY

### Progress in accelerating Self-supply

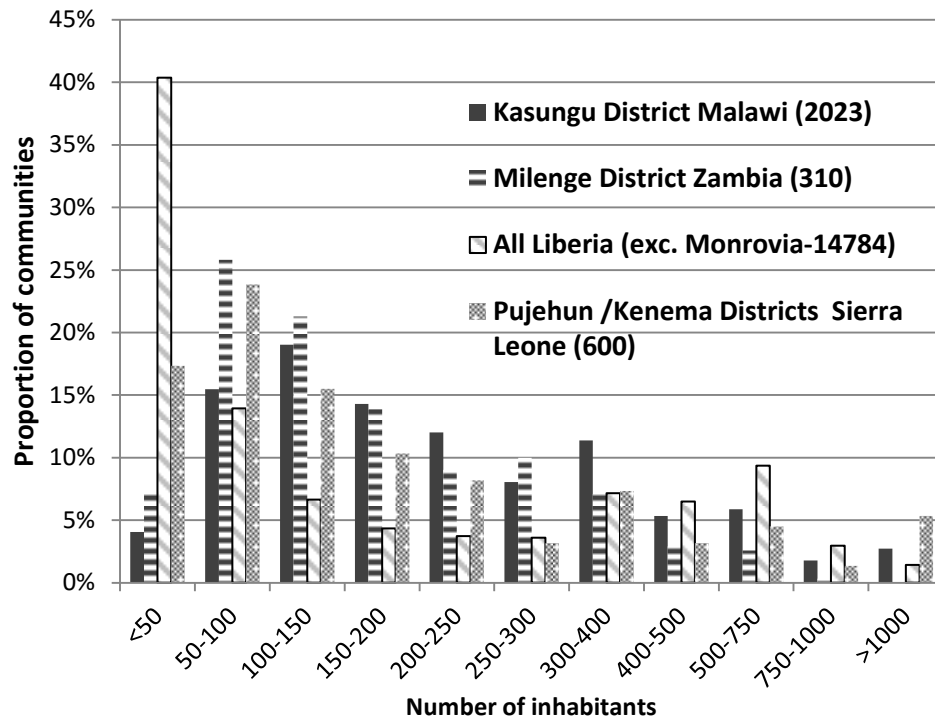

Figure 3: Examples of distribution of community size

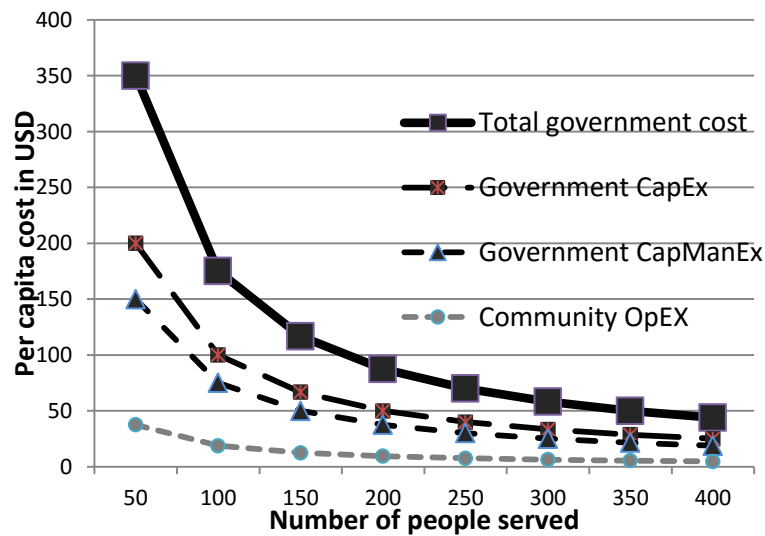

Figure 4: Per capita life cycle costs (LCC) for a borehole with handpump

The life cycle is calculated over a period of ten years and includes only capital costs, software and technical support (CapEx - government cost), minor maintenance and repairs (OpEx- 100% community cost) and major repairs/ replacement (CapManEx- government cost). Communities seldom pay more than a very low proportion of the capital costs. Overall it can be seen that the total per capita cost to the public sector of serving 250 people is around USD 70 (USD 30/head initial capital cost), but rises to over USD 300 in communities of 50 people or less. Overall the basic capital cost is taken to be USD10,000, the life cycle cost almost doubles this, with users paying approximately 10%.

Rate of coverage may be only need to increase by a factor of three, but the annual rate of construction and funding needed to serve smaller communities with conventional handpumps and boreholes will need to be six times or more what it has been in the past. That is without including any increase in construction, technical support and maintenance costs to cater for the more remote and inaccessible



## ACCELERATING SELF SUPPLY

### Progress in accelerating Self-supply

nature of many of these communities. Availability of such an increase in public funding has to be questioned in a time of reducing ODA to sub-Saharan Africa (OECD 2015).

Communities themselves, in the WashCost model, pay an additional 10% in small scale repairs and maintenance and in some cases community contribution to construction costs. With a design population of 250 people the contribution per household would be USD 40-50 over ten years. However the cost to the community, where the number of inhabitants falls below 250, rises significantly. Overall according to WashCost benchmarks, community recurrent contribution needs to be around USD 0.5-1 per person per year. On average, over ten years this would equate to around USD 1875 for a sustainable system of 250 users, but would still depend on government for replacement costs. Where community size drops to less than 100, community payment would then need to be some USD100 per household (assuming all households pay) over ten years to sustain the supply. Major emergencies which might make it necessary to pay a significant part of this sum in one tranche are likely to be a sizeable threat to sustainability of the supply. Such a burden on small communities is unlikely to be sustainable especially as long as most people depend on the vagaries of rain-fed agriculture and have difficulty to establish long-term savings schemes. The above WashCost figures are regarded as ones which could provide a sustainable supply. Existing community and government contributions to running costs (OpEx and CapManEX) are seldom at this level, hence the proportion of supplies not functioning at any one time and the extended length of time that each may be out of action.

It is apparent that that continuing only with a ‘business as usual’ CWS approach, the ability of both governments and smaller communities to provide adequate capital and recurrent funding to catch up with MDG shortfalls and progress on to sustainable universal access is very doubtful. The public sector continues to focus largely on new construction and to rely heavily on outside funding to patch up the damage of deferred maintenance. With funding and infrastructure constraints which are already encountered, this single approach cannot realistically fit the changing demographic and physical environments in which future water supply provision must operate. Additional approaches need to be developed to cater for the specific problems presented by the remaining unserved communities, where sustainability will be more challenging even than in the communities already nominally served. Such approaches require a better understanding of the ‘unserved’ and their existing water supplies, and how catering for them may also strengthen the sustainability of systems already constructed.

## THE POTENTIAL OF THE EXISTING SUPPLIES OF THE ‘UNSERVED’.

### The growing popularity and contribution of Self-supply.

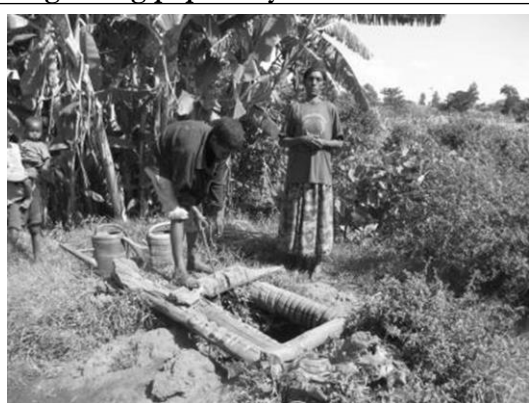

Photo 1 Typical traditional well, Ethiopia

Figure 1 shows that the number of people using unprotected groundwater sources has grown by over 58 million in the past 25 years, and whilst this may partly reflect growing numbers using existing sources, another trend appears also to be developing. Despite the major increase in the provision of CWS, those who are not served, or regard the public service provision as inadequate, are in many areas increasingly investing in their own wells – Self-supply (See Figure 5). Such a trend suggests that public supplies are not satisfying needs but capacity to establish alternatives is growing, if slowly. So far the growth in Self-supply

## ACCELERATING SELF SUPPLY

### Progress in accelerating Self-supply

is almost always without any support from government services. Indeed the construction of new traditional wells<sup>117</sup> (see Photo 1) exceeds the rate at which new boreholes and other public supplies are being constructed.

These developments are not universal but are common in those parts of SSA where groundwater is within some 15m of the ground surface. Overall assessment of available groundwater resources (Adelana + MacDonald 2008) tends to classify them by aquifer type rather than accessibility and reliability, but indicate that some 60-75% of the rural population may live in areas where groundwater is within reach by relatively easy hand-digging or hand-drilling. Unfortunately very few SSA countries yet include self-financed waterpoints in their rural water supply inventories. Only ‘windows’ of information are available to indicate their total number, the rate at which they are increasing, and to identify where potential for their development is highest or where it is so low that boreholes should be given highest priority. Their importance and impacts are therefore largely hidden. In developed countries where rural people can afford to invest in a higher level of service, they are included in inventories and coverage statistics and are shown to contribute significantly to rural water supply coverage (commonly 15-30%). The waterpoint inventory in Uganda in 2010-11 was the first in the country to look for private, as well as public, supplies and caused considerable surprise when it was found that some 10% of protected supplies had been privately financed, and half of these conformed to national standards (SKAT 2015 b) without any advisory or other input from government

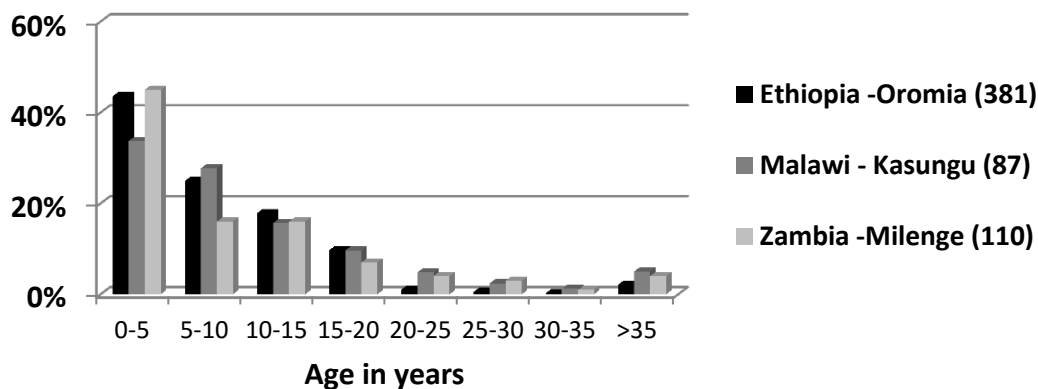

Figure 5: Age of traditional wells in parts of Ethiopia, Malawi, Zambia

Self-supply wells in some areas, especially where groundwater is difficult to access, may be community owned and serve large numbers of people, because the time and cost in providing the supply requires more than the efforts a single family can give. Another alternative in this situation may be household-level rainwater harvesting (RWH). More commonly, however, where groundwater lies within 15-20m of the surface, a single family will take the initiative to finance water supply from a traditional well. This they will share with neighbours, creating a mini-community supply under private management. Average numbers of users tend to be between 50 and 70<sup>118</sup> which minimises problems with queuing and facilitates management and regulation of behaviour. CWS users are generally required to share with 250-300 per handpump, which may in part explain why people living in areas where they can develop their own supplies, are sometimes reluctant to shift to a community-managed supply. CWS are then less popular as households have to fit in with a larger group of users, with the associated problems of queuing, loss of control over management/decision-making, and rules of acceptable behaviour and the loss of status as owner.

<sup>117</sup> Wells which are dug by traditional means and are, at least initially, unlined.

<sup>118</sup> Average from surveys in Mali, Zimbabwe, Zambia, Malawi, Ethiopia (Oromia and SNNPR)

## ACCELERATING SELF SUPPLY

### Progress in accelerating Self-supply



Photo 2 Typical improved Self-supply well, Ethiopia

CWS and self-supply systems are not mutually exclusive. In many cases even households with close access to community handpumps will invest in a traditional well for the flexibility of use it gives both in terms of being able to collect water whenever the owner or neighbour wants it, without time wasted queuing, and in the case of the owner, also for use for various non-domestic purposes such as watering animals or vegetables, food processing or other income-generating activities. In Zambia, in an area of shallow groundwater, the UNICEF/WaterAid study found that of households with a handpump within 50metres 93% also had a traditional well they used within 50m, which provided back-up and a more popular supply. Raw data from surveys of Self-supply and CWS in four countries (Zambia, Malawi, Ethiopia and Sierra Leone) show that most people (70-100%) use more than one source where more than one is available within some 200m. Where such options exist people ‘mix and match’ depending on the time they have available, the pressure of demand on supplies, and other factors.

Self-supply sources of water and CWS generally act as complementary rather than competing supplies, each providing a back-up when the other fails. Handpumps are extremely rarely repaired the same day that they break down. Nor, except in the largest communities are they close enough together that when one fails another is nearby to replace it temporarily. In smaller rural communities with only one handpump, the alternative is generally a Self-supply source. Conversely for many using traditional wells a more distant borehole may often be the back-up should the traditional well dry up seasonally.

However it must be said that in rural areas many self-financed supplies are poorly protected and there is little opportunity for people to get advice on achieving Improved Self-supply with better well-construction, mechanical and motorised lifting devices, productive uses to recoup costs, household water treatment, and elevated storage. The poor quality of completion has led to widespread professional dismissal of these wells as being a liability rather than an asset. The strategy has always been to replace them, albeit with systems that are usually less convenient and not managed at the lowest, most sustainable level. With an estimated 1.7 to 2 million<sup>119</sup> Self-supply traditional wells already established in SSA such dismissal would seem to throw out assets which, if improved in quality and number, could have potential to help fill the gaps which public services are presently unable to fill. Transforming low quality Self-supply into improved Self-supply (see Photos 2-4) may increase coverage cost-effectively.

Reaching an accepted level of supply in self-financed systems is an incremental process. In the case of Zimbabwe self-financed supplies now serve some 34% of the rural population (SKAT/UNICEF 2015 b). Growth in construction of traditional family wells has already commonly resulted in an average of one such well for every 3-4 households, and families have often now moved on from construction of new wells to improvement of those they already have. The main reason for this is that a family well, shared with neighbours, will almost always offer a more convenient supply for nearby households. Complementarity lies not only in each being an insurance for the malfunction of the other, but each may

<sup>119</sup> Based on JMP figures, of the total population using groundwater,

## ACCELERATING SELF SUPPLY

### Progress in accelerating Self-supply

be used for different purposes, or even at different times of year. As a result these supplies, once developed, are seldom totally abandoned in favour of a public facility unless the latter offers reliable water



Photo 3 and 4. Improved Self-supply. Basic levels of improvement in Zambia and Zimbabwe.respectively

piped into the premises. Productive use of the water enables further investment in the supply and in other family priorities. The Government of Zimbabwe has developed Supported Self-supply as a service delivery model, with improved Self-supply as an accepted level of service. As a result a greater proportion of rural people have developed their own supply, and wells and springs are better protected and have proved more resilient during challenging economic times. All pilots studies of support to Self-supply have encountered remarkably high grass roots demand and indicate a very fundamental desire for a supply of ones own. The government add-on is the ensuring of adequate support services to satisfy that demand and to enable and promote best practice.

### **Building on existing Self-supply – See also Olschewski RWSN 2016.**

#### **Supported Self-supply for improved water provision**

The Zimbabwe example has demonstrated that providing necessary support to households wanting to invest in their own higher quality supplies can be achieved largely by expanding the roles of existing extension workers and the skills of artisans, sometimes initially augmented by the inputs of NGOs.. Whilst this approach has here, over 20 years, become embedded in rural water strategy, other countries are now beginning to explore its relevance to their own contexts. Piloting over the last ten years in Zambia, Uganda, Mali, Sierra Leone, Malawi, Tanzania and Ethiopia has indicated that providing support to rural families to enable them to construct and improve water supplies nearer to their own homes can help to reduce the burden on the public sector. The grass roots popularity of this approach is demonstrated by high rates of up-take. Capital costs were generally unsubsidised (except in Ethiopia) but credit/savings systems often proved essential in the poorest areas. Governments in Ethiopia, Uganda, and Mali have now incorporated necessary support services into their rural infrastructure and others such as Malawi and Zambia are considering doing so. Acceptance of the idea is growing at national level as countries begin to identify the challenges they face in reaching universal coverage. At grass roots level demand grows as people realise that donor dependency is not the only way to cope, as they see what their neighbours have achieved that they can copy themselves, a step at a time. For the first time in these countries people are actively being enabled and encouraged to solve their own problem in specific circumstances, rather than depending on the state whose direct support to smaller vilages may be delayed for many years, and may not deliver a solution which best satisfies the needs of others, such as groups of more dispersed households.

## ACCELERATING SELF SUPPLY

### Progress in accelerating Self-supply

Piloting in one of the two poorest districts in the poorest province in Zambia (SKAT/UNICEF 2015a) provoked positive household response and effective improvements to 80% of over 300 existing traditional wells (see Photos 3,4) over a period of a year and a half. Half of these wells reached the defined stage of 'improved supply' in JMP terms during that time, using newly trained masons. The effects on water quality were dramatic, bringing 87% to a faecal-coliform-free state from one where more than half were contaminated. All piloting countries have found that even small improvements in protection have led to significant improvements in water quality and that 'safe' water can be progressively achieved with family investments of as little as USD 200-300. Unlike most community supplies these family or group-owned wells offer the potential for income generation and so too the potential of recouping investment and moving on to higher cost options. In some communities they are regarded by users only in terms of their value for domestic water supply, but even in these the reduction in time saved in water collection was found to lead to improvements in food security ( Sutton et al 2012, PumpAid 2015), amongst both owners and those with whom they share their water.

Local government, national ministries and NGOs need to assess in different country contexts, how best to absorb their supporting roles into existing services. They also need to assess whether or not (and under what conditions) to provide direct subsidies as well as the indirect ones of building up the support services.

### Challenges

The challenges are much as they will be for reaching SDGs in general. The main one is to move from thinking purely in terms of numbers on the ground to thinking about service provision and providing opportunities for all, rather than just solutions for some. In Human Rights terms the UN Rapporteur for Human Rights in Water stated in his presentation for the RWSN webinar on Human Rights and Self-supply (Heller 2015) “ Essentially, the government of any country is obliged to ensure that everyone is able to **access safe, affordable, culturally acceptable water services**, wherever they live and however the service is provided. The government does not have to deliver the services themselves – ..... in rural areas, water is predominantly self-supply in many situations – but they must ensure that there is the right 'enabling environment' that governs this self-supply and safeguards human rights standards.” To maintain an affordability of service may require that different technical standards are developed for communities and for households, and that the enabling environment includes advisory services on 'Progressive realization' which encourages incremental steps for improving water supply. This means accepting that some water sources might not reach 'improved' status in one step and so may not initially provide safe water. However for these people Self-supply might be the only realistic way to get water at all, and the aim must be to enable progressive improvement, as it should be for all supplies, so that even the most marginalised have access to a supply which fulfils their human rights, in a manner that is affordable to the state and to them and so provides a sustainable solution. This approach is a difficult one for sector professionals to embrace initially, but if the constraints of funding and their role as catalysts to improve supply standards are clear their commitment is ensured.

After so many years of donor dependency, it is a challenge to move towards greater self-sufficiency. However the example of households which are early adopters quite rapidly changed the whole atmosphere from one where 'But we are too poor' is replaced by 'Yes we CAN'. The history of the mobile phone in Africa shows that where this shift in mentality is combined with identifying real advantages in investment, progress accelerates and market or social forces, such as 'keeping up with your neighbour', kick into action..

Other challenges include –

- providing back-up to support services for an adequate period for them to achieve quality and sustainability
- structuring direct and indirect subsidies to target the most difficult to reach and enable progressive steps towards safe water for all, especially the most vulnerable.
- combining the social marketing efforts of the several ministries in the public sector and the commercial marketing of the private sector

## ACCELERATING SELF SUPPLY

### Progress in accelerating Self-supply

- assessing the effects of climate change and competition for water resources. Low well density and abstraction rates will rarely cause problems unless water use changes from primarily domestic to primarily productive, when regulation may be required.
- ensuring any development in Improved Self-supply in peri-urban areas is accompanied by sufficient awareness- raising of risks of contamination and by HWTS promotion and
- only actively encouraging the growth of Improved Self-supply where public water supply services are unreliable or inadequate.

Perhaps the greatest challenge at present is that while the figures presented indicate the problems likely to be faced, they are inadequate to give a sufficiently accurate picture of problems or solutions regionally or nationally. All that can be said is that they are sufficient to highlight the challenge of inadequate data and justify a call for much better information and understanding of what people are doing for themselves. They also indicate the need for greater flexibility in solutions offered, and services provided, which move away from the ‘one size fits all’ of the past towards a mutually inclusive approach which embraces more than one option and which views combined approaches using support services in common, as the way forward. Indicators should then move from simply ‘wells completed’ or ‘dollars per handpump’ to aspects such as ‘access to quality support services’, ‘convenience of supply’ and level of supply service..

### Costs of Self-supply Support Services

The capital cost of establishing support service in the public and private sector has generally been in the range of USD 4-20 per head (Kumamaru 2011, SKAT/UNICEF 2015 a + b). This constitutes the indirect subsidy to build up public and private sector support services. In Zambia the higher costs arose where introduction was through NGO (including seed funding for micro-credit), whilst lower costs were experienced where the introduction was totally through government services from the start (Sutton 2002). Government initiatives in Zambia and Zimbabwe show that over time the additional costs to government reduce as the private sector becomes better established/ more sustainable, and more marketing is by word of mouth. Monitoring and regulation then become the main roles and costs remaining in the public sector. Long term costs are greater than capital costs, but overall communities cover some 25% the Life Cycle costs for Supported Self-supply at its lowest level and 10% of those for CWS. In times of reduced donor funding this is an essential attribute.

## ACCELERATING SELF SUPPLY

### Progress in accelerating Self-supply

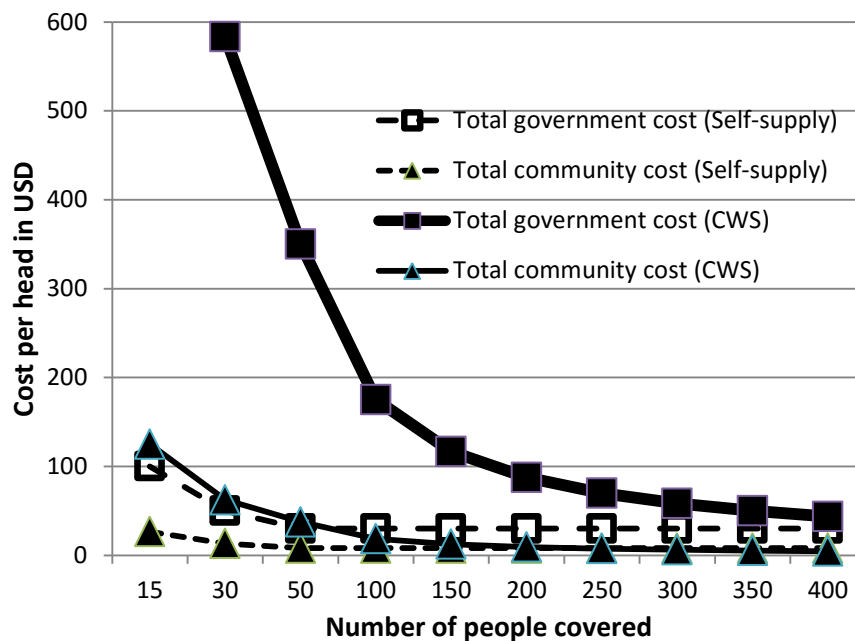

**Figure 6: Per capita costs for government and community with CWS and Self-supply**

Figure 6 shows that per capita cost of Supported Self-supply tends to be a cheaper option for government wherever it is possible, but overwhelmingly so for smaller communities. The reduction in cost is then significant, leaving room for small subsidies if necessary but still providing major savings to the state. However including supportive roles into public and private sectors provides an area- or country-wide service, available to all who are willing to invest in improving their water supply and so may need strategies to target the hard to reach. For communities of over 250 CWS generally provides a higher level of service and remains the cheaper option for households as a whole, a safer option in larger communities and the only option for those where groundwater is not easily accessible or RWH not feasible. Thus a well-designed combination of the two approaches is needed. Using data on population and shallow groundwater distribution in Zambia and Zimbabwe, and a composite strategy of CWS and Self-supply indicates a reduction of capital costs to reach 2030 universal coverage of at least a third to a half (depending on the size of unserved communities). In the case of Zambia this would be over USD300 million at present day prices.

### Conclusions and Recommendations

Governments face a major challenge in reaching universal access to safe water in many countries of SSA. Whilst much progress has been made, funding shortfalls, donor dependency and limitations in construction and maintenance capacity already constrain rates of progress. Yet to achieve universal access by 2030 requires far higher rates of construction than those achieved so far. Bearing in mind the characteristics of many of the remaining unserved communities, the single solution of community managed supplies with handpumps on shallow wells or boreholes cannot provide the whole answer, in terms of affordability or sustainability. Other cost-effective options especially for the vulnerable, scattered households and small communities, but also for those peripheral to public supplies in larger communities need to be developed. In areas where Self-supply is a feasible alternative, encouraging households to aim for Improved Self-supply is one option. Building up support services which enable people to make progressive steps towards safe and affordable solutions, can largely be done through minor expansion of the roles and capabilities of existing government services. In this way Supported Self-supply should form a complementary supply approach, leveraging additional funds, reducing donor dependency and using sustainable technologies and management systems, to achieve a service level which fulfils the human rights of the most difficult to reach. In this way everyone gains (see Table 3)

## ACCELERATING SELF SUPPLY

### Progress in accelerating Self-supply

**Table 3. A win-win situation?**

Stakeholder	Advantages					
<b>Government</b>	Lower costs among the most expensive to cover	Additional leveraged funds and increased coverage	Reduced burden on/stand-by for public supplies	Sustainability		
<b>Private sector</b>	More customers and more (reliable) income	Greater skills and higher quality work	Wider range of services	Sustainability		
<b>End user</b>	More choice in options and access to services	More flexibility in water use	More convenient supply, and food security	Sustainability		

Both in the case of CWS and of Supported Self-supply there are also some risks, and for both the aim must be to assess them, make consumers aware of them and make services available to minimise them. In both cases non-functionality and water quality are the main issues, alongside the symbiotic or competitive relationship between the two approaches.

In that traditional wells are commonly shared with those less able to provide for themselves, and usually offer them a very convenient and free supply, this system caters for the most vulnerable in a way that a community supply seldom can. People are not excluded because they do not pay, and efforts in transporting water are minimised. If these sources can be improved to a level that offers an increasingly safe supply, primarily by the investment of one or more families, they offer an additional option and insurance policy for those people who are far from, or subject to irregularities of conventional CWS. The potential of this option should not be ignored, but should be exploited where possible through cost effective expansion and enhancement of the necessary support services.

### References

- Adelana S and A MacDonald (2008) Applied Groundwater Studies in Africa. IAH Selected Papers Vol 13.
- AfDB 2013 Project Appraisal report Sierra Leone, OWAS Department.
- Heller L (2015) Human Rights and Self-supply, potential and challenges. RWSN Webinar 8 <http://vimeo.com/147012798>
- Kumamaru K, (2011) A comparative assessment of communal water supply and self supply models for sustainable rural water supplies: a case study of Luapula, Zambia PhD Thesis WEDC.
- MEW (2010) Ministry of Water and Environment, Government of Uganda, Uganda Water and Environment Sector report 2010.
- MoWR (2009) Review of rural water supply Universal Access Plan implementation and reformulation of plans and strategies for accelerated implementation. Ministry of Water Resources, Addis Ababa.
- Olschewski A. Supported Self-supply, learning from 10 years of experiences. RWSN Forum proceedings 2016.
- OECD 2015 Development finance statistics Bulletin 08/04/201
- SKAT/UNICEF(a) (2015) Review of Self-financed Water Supply in Milenge District, Zambia. Country report for consultation.
- SKAT/UNICEF(b) (2015) Review of Up-graded Family Well programme in Makoni and Buhera Districts, Manicaland Province, Zimbabwe. Country report for Consultation. UNICEF ESARO Nov 2015.
- SKAT/UNICEF (c) 2016 Review of Self-supply in African Countries. Considering findings from Zambia and Zimbabwe. Draft synthesis report.
- Sutton (2002) Community led improvements of rural drinking water supplies. KAR 7128. Dfid Final report.
- Sutton S, J Butterworth, L Mekonta (2012) A Hidden Resource- Household-led rural water supply in Ethiopia. IRC International Water and Sanitation Centre, Netherlands.
- PumpAid 2015 Self-supply Potential in Kasungu District, Context report. March 2015.



## **ACCELERATING SELF SUPPLY**

### **Progress in accelerating Self-supply**

UNICEF 2011 Impact evaluation of drinking water supply and sanitation interventions in rural Mozambique. Mid-term evaluation. October 2011  
WASHCost (2012). Providing a basic level of water and sanitation services that last. Cost benchmarks. WashCost Info sheet 1. October 2012  
WaterAid (2008) Technology Study Final report, Zambia

## ACCELERATING SELF SUPPLY

Progress in accelerating Self-supply

---

# A business case for supported Self-supply as service delivery approach to achieve SDGs

---

Type: Short Paper

Authors *André Olschewski, Skat Foundation, Switzerland*

### Abstract/Summary

Supported Self-supply is highly relevant as a complementary service delivery model for rural water supply since conventional water delivery services would simply be too expensive to ensure universal access to safe water, which is defined as SDG target 6.1. Many rural households invest in improving water supplies of their own as they highly appreciate the convenience of supplies close by their homes, having access to more and safe water, which enables them to improve food security and health standards and start income generating activities. Data from a recent review of supported Self-supply initiatives show that costs for achieving universal access in rural areas of Zambia and Zimbabwe for government can be reduced by about 50% if a mixed approach is followed. However, specific support services designed to the context are needed to trigger uptake of Self-supply. To become a sustainable service delivery approach, even in rural areas, specific support services need to be embedded adequately in government systems utilising the potential of the local private sector and synergies with activities in other sectors.

### Introduction

Self-supply can be defined as incremental improvements which are financed by households or small communities with the objective to improve supply of WASH products and services or to improve water quality (Olschewski 2016). Self-supply is common practice in many countries, and in combination with specific support services, it has a great potential for supporting and achieving several SDGs (Olschewski, Waterkeyn, Matimati, 2016). Government has to take on specific roles and tasks so that Supported Self-supply as a service delivery approach complies with the requirements and principles of the Human Right to Water (Heller 2015).

There are many case studies documenting experiences of Self-supply from various countries, and they are available e.g. as RSWN field notes. So far, however, there has been no systematic review of former piloting or scaling up of Supported Self-supply looking at costs of implementation and lasting impacts of Supported Self-supply. This paper reflects the findings of a review of Supported Self-supply in Zambia and Zimbabwe which was conducted by UNICEF ESARO in 2015. Particular emphasis is put on the costs of different service delivery approaches, the roles of government and the need for embedding support in existing structures.



Photo left: Upgraded Family Well (UFW) in Zimbabwe; Photo right: Upgraded traditional well in Zambia

### Description of the Case Study

In 2015, a review study was conducted in both countries to assess the impact of former piloting and scaling up of Self-supply and to assess the potential of Supported Self-supply as a complementary service delivery

## ACCELERATING SELF SUPPLY

### Progress in accelerating Self-supply

approach for achieving the SDG on water. The review included field surveys with household interviews, key informant interviews, workshops at regional and national level for consultation as well as water quality surveys at sources and point of use. The details on data collection methodology and findings on water quality are documented in the country reports for Zambia (Olschewski, Sutton, Ngoma 2016) and Zimbabwe (Olschewski, Waterkeyn, Matimati 2016).

#### Piloting in Zambia

Supported Self-supply was piloted in Luapula Province in the Northeast of Zambia from 1998 to 2014. Luapula province is a particularly sparsely populated, very remote and difficult to access rural area. The idea of piloting Self-supply in that region was to assess if and how Self-supply supported through specific support services could be a viable service delivery option even under difficult conditions.

Supported Self-supply was piloted in Luapula Province in three successive, relatively short phases of 2-4 years using a project approach:

- 1998-2001 DFID funding to Department for Water Affairs and Ministry of Health in 3 provinces,
- 2007-2010 UNICEF funding to two NGOs, “WaterAid Zambia” and “DAPP”, in 3 districts in Luapula, including Milenge West, and
- 2012-2014 Stone Foundation funding to “WaterAid Zambia” in Milenge East.

In the first phase, piloting was implemented jointly by various Ministries. However, due to institutional reforms in a later stages, piloting was implemented by local NGOs. During the process, different support services were provided, which included sensitisation of local leaders and of households to the approach, training of masons in improving traditional wells, and a partly bulk supply of input materials. In a later stage, loans were also provided through a loan scheme to help households investing in improvements (Ngoma and Sutton 2016).

#### Scaling up of Upgraded Family Wells in Zimbabwe

In Zimbabwe, the Upgraded Family Well (UFW) programme was introduced at national level through government systems in 1995. The government was involved in promoting the approach, improving the technical solutions by Blair Research Laboratory in Harare and through follow-up at local level by Environmental Health Technicians (EHT). Support services were established to take the UFW programme further at local level and included sensitisation of communities and training of masons in upgrading traditional wells. Additionally, families who had dug and fully lined their well at own costs could access an in-kind subsidy for further improving their family well. The investment costs for full lining of wells were about US\$ 200-300, and full lining was a conditionality to access subsidy. The in-kind subsidy consisted of a lid, a steel windlass and 2-3 bags of cement for the cover and apron and was worth about US\$50-60. In some areas, hygiene education was provided additionally, including training on gardening following the Community Health Club approach (CHC) (Waterkeyn and Cairncross 2005). The training of masons and provision of subsidy was funded by donors and run by local NGOs (Mvuramanzi Trust) and by ZimAHEAD for the CHC training. In 2000, the economic crisis resulted in funding for support services, including in-kind subsidy for the UFW programme, being stopped almost completely. Funding for sensitisation and follow-up by EHTs ended too.

#### Main results and lessons learnt

##### Self-supply satisfies needs of people

In household interviews, Self-supply was highly appreciated as the water sources which are often located close to homes provide a high level of convenience. Families stated that they were now more flexible in choosing when to fetch water and that more family members could be involved in fetching water. Additionally, Self-supply sources allow access to more water, which is often used to improve hygiene behaviour, nutrition e.g. through gardening or starting other income-generating activities.

The pilots in **Zambia** showed a high uptake of the solutions, which reflects a strong need of households to improve their water supply as community supplies are not reliable or not close enough to homes. However, to establish sustainable support services in such remote areas, where the local private sector is struggling to

## ACCELERATING SELF SUPPLY

### Progress in accelerating Self-supply

take off, there is a need for sufficient and reliable funding of the “software” side of activities, for sensitisation of local leaders, for facilitation of loan schemes or for follow-up, also to improve quality of works (Olschewski, Sutton, Ngoma 2016).

This applies in particular to **Zimbabwe** and areas where special training has been provided, such as that through CHC. In Zambia, gardening was not practised much so far, neither was there so much emphasis on training. In many rural areas, households invested in their own supplies even if public supplies were provided nearby, such as in Zambia. In Zimbabwe, from 1995 to 2015, more than 180,000 wells were upgraded in rural areas, providing about 2-3 million people with water for domestic and productive use (see Figure 1). As after 2000 no more in-kind subsidies and other support were granted, this uptake represents a real success story of scaling up. However, due to the economic crisis, proper follow-up was no longer provided, and quality and maintenance of assets was decreasing (Olschewski, Waterkeyn, Matimati, 2016).

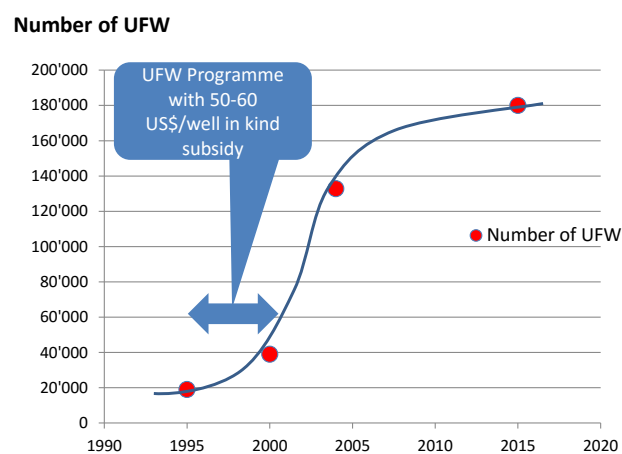

Figure 1: Scaling up of the Upgraded Family Wells (UFWs) in Zimbabwe

### Specific support services required for Self-supply

Self-supply activities are embedded in a market-based approach, where support services for Self-supply should systematically strengthen the demand side, the supply side as well as the enabling environment. Figure 2 shows core elements of Supported Self-supply interventions as a systematic approach which needs to be in place to stimulate market development, to improve the level of services and to ensure that Human Right principles are adhered to (Olschewski 2016).

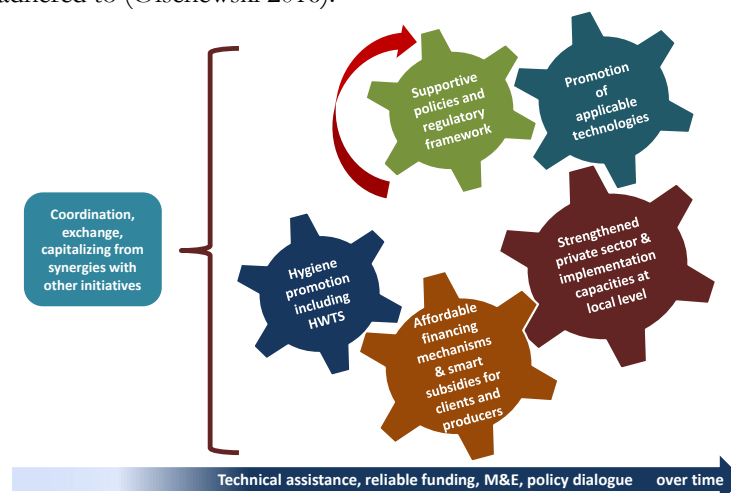

Figure 2: Support services for Self-supply

## ACCELERATING SELF SUPPLY

### Progress in accelerating Self-supply

The range of support services includes technology development, sensitisation of local leaders and community members, training of masons in technical and business skills, facilitation of loan schemes or follow-up. The art in supporting Self-supply is to design context specifically and to embed these support services in government systems or in private sector cooperation in a way which allows for a viable and sustainable support of Self-supply. In Zambia, this effort was hampered by changing institutional set-ups (in particular, different Ministries and NGOs were involved) and by a rather short phase of piloting. In Zimbabwe, a strong set-up was in place up to 2000 with well-established procedures and strong linkages to the national, regional and local levels when scaling up started.

In establishing support services, one needs to bear the context in mind, in particular what people's needs are, capacities of the sector and physical and socio-economic conditions. Promotion of new technologies has to consider previous attempts to avoid supporting stigmatised technologies, such as the Elephant pump in Zimbabwe. Activities should be coordinated with those in other sectors such as sanitation, hygiene, nutrition, microfinance and income generation in order to capitalise synergies.

### Champion(s) and government's roles in supported Self-supply

In Supported Self-supply, government has to take on specific roles to ensure that universal access to safe water for all is finally ensured (Heller 2015). Depending on the context, specific roles of government include recognition of the approach and integration in policies, assessing potential and applicability, financial support including “smart” subsidies that do not lead to market distortions, sensitisation, technical advice, and monitoring and evaluation (M&E). Government should also link different initiatives, e.g. for health promotion, to create synergies, e.g. with initiatives for sanitation marketing and Community approaches to Total Sanitation (CATS), and should trigger vertical and horizontal sharing and learning. Sufficient time and reliable funding and follow-up are needed to allow Self-supply to grow. However, to bring all components together and to push the agenda, at least one committed champion is needed!

In **Zambia**, Self-supply was piloted in project approaches after rather a short time; however, it did not become part of a formal national strategy. During the projects, various Ministries were involved and acknowledged the relevance of the approach. However, at the end of the pilot projects, a clear institutional ownership was missing to take findings up to the national level.

In **Zimbabwe**, the UFW programme started as part of the national programme, mainly driven through the Ministry of Health and Child Care. Additionally, strong actors were in place developing the technology and providing high-quality training. Champions within these organisations created a critical mass of actors which were actively supporting the UFW and were vital to take the UFW programme further even after 2000, when funding decreased dramatically. Based on the results of the review, much more energy came into the sector so that recommendations were taken up in the national road map in 2016.

### Need for holistic approaches and intersectoral cooperation

Community managed water supplies such as piped schemes follow a mono-sectoral approach as they focus mostly on providing water. However, for supported Self-supply, a more holistic approach is needed to also address issues of hygiene and safe water and to capitalise on opportunities such as from gardening for nutrition, vocational training or income generation. Combined support approaches and proper follow-up have a wide range of positive impacts, including better health and nutrition status and a higher level of income-generating activities (Olschewski, Waterkeyn and Matimati 2015). Holistic approaches call for the involvement of key actors from various sectors and Ministries. The experiences from Zambia and Zimbabwe show that cross-sectoral approaches with different Ministries participating at local level strongly increased the performance of Supported Self-supply and through this fostered the achievement of several SDGs, e.g. for health, nutrition or water.

### Water quality and need for hygiene education and promotion of household water treatment

Water quality samples from 200 water points [with handpump, improved traditional wells (ITW), semi-improved traditional wells and unimproved traditional wells] were taken during the dry season and were ana-

## ACCELERATING SELF SUPPLY

### Progress in accelerating Self-supply

lysed onsite on various parameters including Thermo Tolerant Coliforms (TTC) as an indicator of bacteriological contamination.

In **Zambia** 95% having less than 10TTC/100ml and 83% with none (see Fig 3). The review confirmed earlier findings that minor improvements in well head protection can significantly reduce faecal contamination at source (Sutton, Butterworth, Mekonta 2012; Sutton 2015).

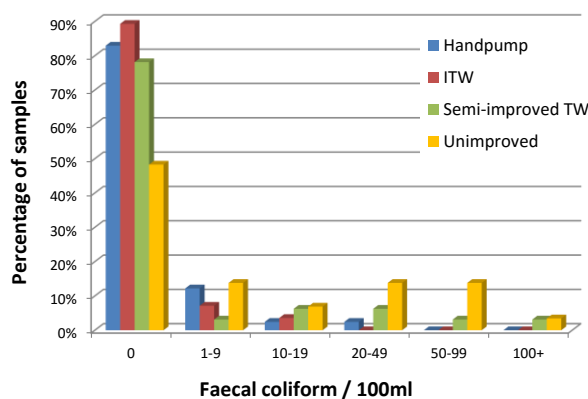

Figure 3: Water quality in wells in Zambia (n=200)

In **Zimbabwe**, a slightly higher level of contamination was observed, even in improved wells, as was a high Nitrate level. Also, in some examples from community water points using deep boreholes and handpumps had some faecal contamination and high Nitrate level. It looks as if the heavy use of fertiliser over years could explain the high level of Nitrate in the area. More follow-up is needed to verify the water quality data, including on causes of bacteriological contamination.

As recommended by WHO for any rural water supply, intervention programmes for supported Self-supply should also include hygiene education, water safety plan and promotion of use of household water treatment as a standard component (WHO 2015).

### “Business case” for supported Self-supply – costs for government and for households

Based on the data from the review of supported Self-supply in Zambia and Zimbabwe, a cost analysis using the Life Cycle Costs (LCC) method was performed for achieving universal access for rural population in Zambia and Zimbabwe in 2030. Two scenarios for service delivery options were compared and discussed: a) the community managed approach using boreholes and handpumps (CWP) and b) the mixed approach, which combines community supply and supported Self-supply where applicable.

Life Cycle cost for government	Cost components considered in LCC (life time over 10 years) for government	Specific costs for government	Specific costs for households (owner)
<b>Community Water supply</b> using a community water point (CWP) e.g. borehole with handpump for 250 persons)	<ul style="list-style-type: none"> <li>- CapEx: 100% investment of a community water point</li> <li>- aggregated costs for major repairs and maintenance</li> <li>- Support costs: specific costs for sensitisation, hygiene training and follow-up</li> </ul>	<b>40 US\$/cap</b>	<b>In kind contribution</b>
<b>Supported Self-supply</b> (Upgraded family well with 15-20 users)	<ul style="list-style-type: none"> <li>- CapEx: no investment except subsidy of about 50-60 US\$/well</li> <li>- Support costs: specific costs for sensitisation, hygiene training, training of masons, and for follow-up including sensitisation;</li> </ul>	<b>10 US\$/cap</b>	<b>250-300 US\$</b>

Table 1: Cost comparison between community water supply and supported Self-supply (cost data from Zimbabwe)

## ACCELERATING SELF SUPPLY

### Progress in accelerating Self-supply

The specific LCC cost for government is around 40 US\$/cap for community water points using borehole and handpump and about 10 US\$/cap for supported Self-supply for improved wells. The support services for Self-supply in Zimbabwe included an in-kind subsidy worth 2-3 US\$/cap as well as costs for sensitisation, training of masons and follow-up. Experiences from Zambia show that if support services are embedded in government systems, the costs can be reduced.

Household water treatment and safe storage (HWTS) should be included in any water supply service as many supplies including community supplies don’t provide safe water at all times (Bain et al 2014, WHO 2015). If a water filter were included as part of a support package, the capital costs per person would increase by around 5-10 US\$/cap.

Based on these data, the estimated costs to reach universal access for water in rural areas in Zambia and Zimbabwe are very high, also because remote and sparsely populated areas need to be reached (Figure 4). This cost calculation considers the fact that Self-supply is not applicable in all regions of Zambia and Zimbabwe owing to geological and hydrogeological conditions.

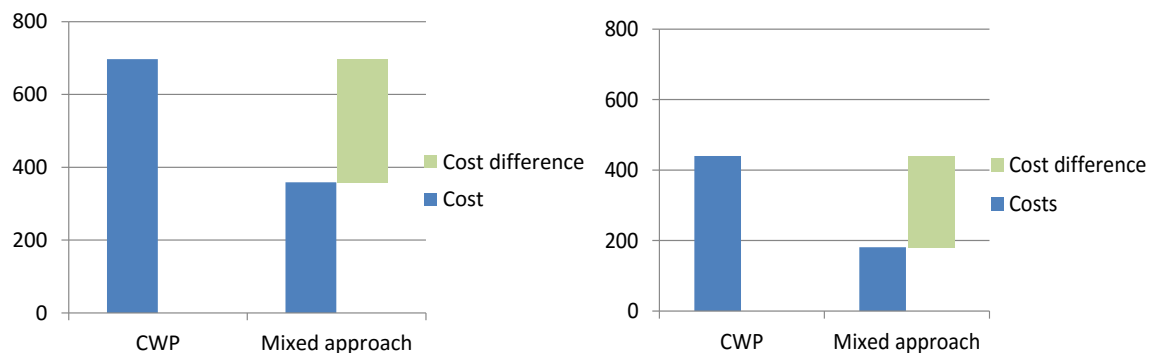

Figure 4 LCC Costs for government to achieve universal access in 2030 for Zambia (left) and Zimbabwe (right) through a community water point (CWP) equipped with a handpump on a borehole or a mixed approach.

However, there are huge differences in costs between the two scenarios which could be followed. If a mixed approach is used (CWP and Supported Self-supply where feasible), the costs for government will be 200-300 million US\$ less compared to the option where only community water supplies are used. This translates into reduced costs for government for achieving universal access in rural areas of about 50% in Zambia and about 60% for Zimbabwe. Part of the huge cost difference can be explained by major parts of the investment costs in the mixed approach being covered by the households (by definition for Self-supply). However, the biggest part of the reduction is due to the choice of more cost efficient solutions in supported Self-supply. Serving households in remote scattered settlements with CWPs is extremely costly as the specific costs increase the less people can be served additionally.

## Conclusions and Recommendations

The SDGs for water can only be achieved using a mixed approach combining community supplies and supported Self-supply where feasible. Supported Self-supply should be recognised by more governments and development partners as a viable complementary service delivery model for water which also supports achieving other SDGs, such as those for health and nutrition. Supported Self-supply is not a way to exempt government from its duties. Moreover, following it as a gradual approach or a mixed approach is the only way for government to ensure that people have access to safe water finally.

For a successful uptake of Self-supply, specific support services need to be established with sufficient funding. However, there is no silver bullet solution. Design and implementation of support services very much depend on the context.

## ACCELERATING SELF SUPPLY

### Progress in accelerating Self-supply

In remote rural areas, government needs to take on a strong lead and promote and support Self-supply and open up synergies with other sectors, such as with CATS in sanitation. Contexts with more favourable hydrogeological conditions and a vibrant private business sector might offer good opportunities to involve the local private sector more actively in providing some of the support services, such as around bigger villages and in peri-urban parts of Zambia, Tanzania or Sierra Leone. The review confirmed earlier findings that minor improvements in well head protection can significantly reduce faecal contamination at source (Olschewski, van Donk, Mallio 2015). However, government should always participate (Heller 2015).

### Acknowledgements

The support of UNICEF ESARO regional office (Dr Peter Harvey) and of the team members for the review (Dr Sally Sutton, Anthony Waterkeyn, Michael Ngoma and Regis Matimati) is gratefully acknowledged.

### References

- Bain R, Cronk R, Wright J, Yang H, Slaymaker T, et al. (2014): Faecal Contamination of Drinking-Water in Low- and Middle-Income Countries: A Systematic Review and Meta-Analysis. *PLoS Med* 11(5): e1001644. doi:10.1371/journal.pmed.1001644
- Heller Leo: Self-supply and Human Rights – Potential and challenges; in RWSN Webinar 24.11.2015 <https://vimeo.com/147012798> and <http://www.rural-water-supply.net/ressources/documents/default/1-748-2-1456497064.pdf>
- Olschewski, A. (2016) Synthesis report - Review of support Self-supply; for UNICEF ESARO (<http://www.rural-water-supply.net/en/resources/details/753>)
- Olschewski A., van Donk M., Mallio J. (2015): Innovative mechanisms for improving Self-supply services: <http://wedc.lboro.ac.uk/resources/conference/38/Olschewski-2287.pdf>
- Olschewski, A. (2016): Supported Self-supply – learning from 15 years of experiences - Background Paper submitted for the 7th RWSN Forum, Abidjan.
- Olschewski, A., Sutton, S. and Michael Ngoma (2016): Country report Zambia; for UNICEF ESARO. (<http://www.rural-water-supply.net/en/resources/details/754>)
- Olschewski, A., Waterkeyn, A. and Regis Matimati (2016): Country report Zimbabwe; for UNICEF ESARO. (<http://www.rural-water-supply.net/en/resources/details/755>)
- Sutton, S., Butterworth, J. and Mekonta, L. (2012): A hidden resource: household-led rural water supply in Ethiopia. IRC International Water and Sanitation Centre, The Netherlands (<http://www.rural-water-supply.net/en/resources-top/details/406>)
- Ngoma, M. and Sutton, S. (2016): towards universal coverage – Self-supply as part of the solution for the hard-to-reach in Zambia; paper presented at 39<sup>th</sup> WEDC 2016, Kumasi, Ghana.
- Waterkeyn, J. & Cairncross, S. (2005). Creating demand for sanitation and hygiene through Community Health Clubs: a cost-effective intervention in two districts of Zimbabwe. 61. *Social Science & Medicine*. 1958-1970
- WHO (2015): WHO Ethiopia (2015): Is household water treatment and storage part of the answer to safe water supplies? YES! <http://www.rural-water-supply.net/ressources/documents/default/1-662-2-1428938050.pdf>



## ACCELERATING SELF SUPPLY

Progress in accelerating Self-supply

# Supported Self-supply – learning from 15 years of experiences

Type: **Background / Input Paper**

### Authors

André Olschewski, Skat Foundation, Switzerland

### Abstract/Summary

Evidence from the field shows the huge relevance of Self-supply water sources and the broad benefits of household investments in own water sources. Supported Self-supply as a service delivery approach might not be applicable in all regions. However, in many countries and for millions of people, Self-supply sources will be the only access to water for many decades as there is not sufficient funding to establish community supplies for all. Learnings from different case studies show which support services are needed and which roles governments and other actors need to take on to ensure that access to safe water is achieved. In many rural areas, a complementary approach using communal supplies and Supported Self-supply will be the only way to achieve SDGs.

## 1 Background

### 1.1 What is “Self-supply”?

**Self-supply** can be defined as incremental improvements in the supply of WASH products and services, e.g. water supply and sanitation structures, by a household or a small group of households, chiefly financed by themselves. Self-supply is an extensive and inclusive way of providing water. It has been practised by people for centuries and can be found all over the world, as many households have built and improved their own water sources, e.g. hand-dug wells or rainwater harvesting tanks by their own means. In most cases, such Self-supply sources are used for different purposes, such as for drinking water, food processing, brick making as well as for agricultural purposes without any external support programme.

Self-supply is not necessarily a “pro poor” or an “inferior” approach. Still today, millions of people in countries like the USA, the UK or Switzerland rely on Self-supply sources as the only source of drinking water (<http://water.usgs.gov/watuse/wudo.html>, WHO 2011). In these countries, specific regulation has been established for private supplies to ensure good practice of water source protection, adapted water safety plans and regular self-control of water quality (e.g. from Scotland <http://www.gov.scot/Topics/Environment/Water/17670/pws> and <http://dwqr.scot/private-supply/pws-owners-and-users/>). Such examples show that Self-supply is not linked to a particular socio-economic status, rather that it is based on strategic choice of a cost effective service delivery approach which considers the context-specific needs and opportunities for a given period of time.

In contrary, people usually strive for better options, and Self-supply can be a starting point to improve the level of service of communal supplies. For example, in rural areas of Mali, better-off families and parts of the communities are using own funds including remittances to improve and extend existing public supplies to have a better level of service as the existing communal supplies do not always provide adequate level of service (see input by Daniel Maizama: <https://vimeo.com/121332803>). In rural Ethiopia, several families group together to pool funding to purchase a group Rope pump. Moreover, for millions of people in Eastern Europe such as in Ukraine, Moldova or Albania, Self-Supply sources are currently the only fall-back option, as public supplies have collapsed in rural areas to a large extent. Even in EU Member States such as Romania, where coverage through public water supplies is increasing, not all citizens are served, particularly in the rural regions. In such areas, Self-supply will continue to be a highly relevant supply approach for years.

## ACCELERATING SELF SUPPLY

### Progress in accelerating Self-supply

Country	Ukraine	Moldova	Romania	Albania
Population (2013):	45.49 million	3.559 million	19.964 million	2.774 million
% of people using Self-supply	35%	57%	38%	22%

Source : [www.danubis.org](http://www.danubis.org)

Currently, the World Bank is looking for more detailed data in that region to better understand the scale of Self-supply and how to best support the level of service provided.

In developed countries with high levels of operational reliability in public supply, Self-supply is mostly limited to those areas where people are so dispersed that it is not cost effective to link them to the public service. Remote householders provide their own supplies, initially at their own cost but with opportunities to access grants or loans to up-grade them. In the USA, Self-supply withdrawls provided water to more about 44 million people in 2010, mainly using groundwater sources (<http://water.usgs.gov/watuse/wudo.html>). In Ireland, 10% of households do so through small group or household investment (Brady and Gray 2010).

Global patterns suggest that achieving universal coverage almost always requires a level of household investment. However for many households in remote rural areas, e.g. in Sub-Saharan Africa Self-supply will remain the only water supply for many years to come.

### What are particular characteristics of “Self-supply”?

From the point of view of water supply provision, Self-supply has some particular characteristics and faces some challenges which need to be addressed to improve quality of service and to change attitudes and practices within the sector. Particular characteristics and challenges include:

- In Self-supply, the households are sitting in the driving seat for planning on when and how to improve the level of service, they take the decision on how they can mobilise sufficient resources for investments and for covering running costs, and they have to manage the supply and care for maintenance and follow-up. This is different from other services approaches such as community managed supplies, where the planning is done mostly by local government authorities or NGOs and investments are heavily subsidised as they come from outside the community.
- Self-supply is not linked to any specific technology such as the Rope pump or manual drilling. However, some low cost technologies are more often found with Self-supply than with other approaches. For Self-Supply affordability of upfront investments, capacities for operation and maintenance and viable supply chains are decisive factors for deciding on a specific technology and level of service.
- Measures for improving quality of own water sources by households mostly follow incremental improvements along the water ladder (Figure 1). This means that improvements in supply and quality might not be achieved in one big leap but in several small steps depending also on the aspirations and needs of households and the resources available to them (Sutton 2011). However, even technologies at the lower part of the ladder might provide services 24/7 all year round.
- Self-supply is a demand-driven approach. To achieve progress, households need sufficient funding, or access to affordable financing mechanisms and to a viable private sector which can provide technologies and services which fit the context, as well as a viable supply chain.
- Self-supply sources are often shared with neighbours, frequently at no costs for them. In many countries, such as Zambia, Zimbabwe or Sierra Leone, well owners and users confirmed that Self-supply sources were often shared by more than 30-40 persons or more, so that Self-supply actually became an almost semi-public supply.
- For elderly and disabled persons, shared Self-supply sources are often the only sources which are easily accessible in rural areas, making Self-supply an inclusive approach.

## ACCELERATING SELF SUPPLY

### Progress in accelerating Self-supply

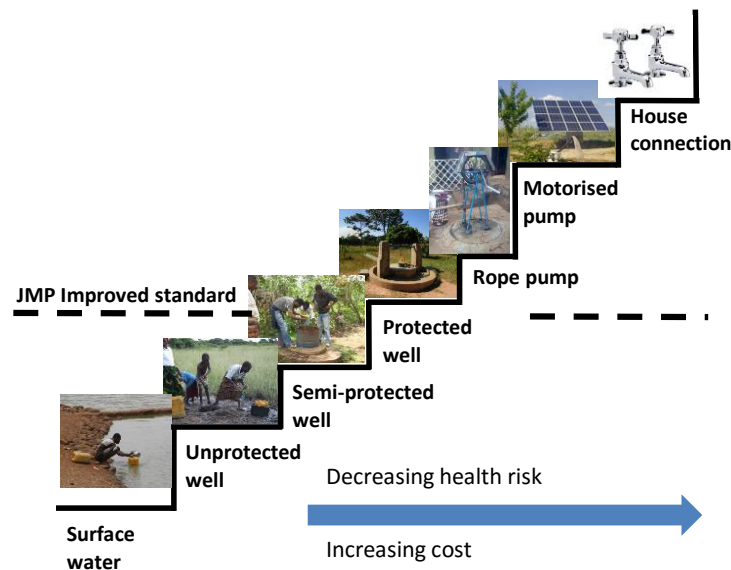

Figure 1: Self-supply – incremental improvements along the water ladder

- Self-supply might happen even without intervention of NGOs, governments or donors. In Nigeria or Chad, thousands of domestic wells have been drilled by independent drillers who were funded 100% by households without any guidance or supervision of any local government (Danert, Adékile and Gesti, 2014). Particularly in urban areas, there is a big potential challenge, with water quality originating from uncontrolled drilling activities.

Thus, we can summarise these points in stating that Self-Supply is:

- technology-neutral
- incremental
- demand-driven
- often benefiting more people than the users/owners
- inclusive
- happening already in most of the world.

Looking at the development of water supply delivery in a particular area over time, it is important to emphasise that Self-supply moves people just one step up on the ladder but does not automatically lead to universal coverage of all with safe drinking water. An even higher level of service might be achieved by more advanced Self-supply solutions, e.g. the submersible pump. However, it is important to highlight that for millions of people, Self-supply will remain the only approach at least for the next two or three decades. This is particularly true for millions of families in the South, especially in remote rural areas of Sub-Saharan Africa (SSA), where progress in terms of increasing coverage and approaching the SDGs by 2030 through public supplies alone will be very slow if at all feasible.

### Relevance of Self-supply and domestic investments in WASH

According to the GLAAS report 2013/2014<sup>120</sup>, 19 countries indicated that nearly 75% of their WASH financing was derived from household contributions (as tariffs and for Self-supply). Only 25% came from government and donors. However, at the moment, hardly any detailed data is available at national level on the extent of Self-supply in many countries, as hardly any national monitoring and evaluation systems have included Self-supply water sources such as hand dug wells in their regular procedures and data collection systems.

One positive example is Zimbabwe, where the national monitoring system includes both unimproved and improved traditional wells. Currently, the ongoing GLAAS report survey 2016/2017 is collecting even more

<sup>120</sup> [http://www.who.int/water\\_sanitation\\_health/glaas/2014/en/](http://www.who.int/water_sanitation_health/glaas/2014/en/)

## ACCELERATING SELF SUPPLY

### Progress in accelerating Self-supply

detailed data on household’s investments for Self-supply which will provide very useful information to showcase the relevance of household investments in the water sector already today.

However there are a couple of data which indicate that Self-supply is an extensive form of water supply:

- In Africa, millions of hand dug wells are used as Self-supply wells, and the number is still increasing, which stresses the fact that there is need and demand for Self-supply (Sutton and Olschewski 2016).
- Also in various emerging economies such as in South Asia, where full coverage has been reached, Self-supply sources were major steps on the water ladder to achieve full coverage. For example, Thailand’s mainly household-financed rain water harvesting initiative was crucial for the country on its way to universal access in the past 20 years (Saladin 2016).
- There are also middle-income countries in Latin America, such as Colombia (rural coverage 74% according to WHO/JMP figures), or countries like Malawi in Africa, where coverage in rural areas has reached a high level with 89% struggling to further increase the level of coverage and improve the level of services using centralised approaches and where Self-supply in some rural areas is used intensively (for an example of Self-supply in Colombia<sup>121</sup>).

### 2 Why do households invest in own sources?

Self- supply is practised where no other services are in place which provide sufficient, reliable and affordable supply for the water needs of households. It is practised in rural areas as well as in peri-urban areas where public entities fail to provide an adequate level of service, or in informal settlements where public supplies are often completely absent.

Even in remote rural area where people depend on little cash income and subsistence farming, households invest up to 200-300 US\$/well to dig and improve an own well. These costs are huge compared to the income, so the expected benefits have to be significant. In various household surveys, households reported on various factors which are key to their investing in own supplies. Apart from many other key aspects, there is one which is clearly ranked highest in almost all surveys: **Convenience** (e.g. Sutton, Ngoma, Olschewski 2016).

---

<sup>121</sup> <http://revistas.javeriana.edu.co/index.php/iyu/article/view/12223/12533>

## ACCELERATING SELF SUPPLY

### Progress in accelerating Self-supply

**Table 1: Key benefits and motivation for households to invest in improving Self-supply sources**

Key feature	Particular impact
Convenience Convenience Convenience!	<ul style="list-style-type: none"> <li>First of all, there is the aspect of saving time and effort for fetching water and having less of a burden. Further benefits include having more water available for income generation and improving food security, more water with better quality, a high level of service (24/7), reliability, privacy and security.</li> </ul>
Strong ownership	<ul style="list-style-type: none"> <li>Self-supply is based on household initiative. It is fully demand-driven. As almost all investments are covered by households, there is strong ownership.</li> </ul>
High potential for sustainability	<ul style="list-style-type: none"> <li>There is widespread knowledge on how to operate Self-supply sources or where to go to ask for support.</li> <li>Households care for their assets and do proper maintenance, so that the functionality of their supply is very high. Sustainability of Self-supply is very high as long as resources are managed properly.</li> </ul>
Self-supply sources as shared supply / Inclusion	<ul style="list-style-type: none"> <li>In most regions, Self-supply sources are shared with neighbours at no additional cost for the well owner and no cost for sharer. These sources serve several families, including the most vulnerable and poorest ones. For countries such as Uganda, Mali and Zimbabwe, we know that some sources are shared with up to 50-70 people, thus becoming almost communal supplies (Sutton 2015).</li> </ul>
Multiple uses of water	<ul style="list-style-type: none"> <li>Self-supply sources are mostly used for domestic purposes. In many areas, there is a huge potential to expand the use of water also for productive purposes, such as gardening, cattle, or brick making, which provide opportunities for income generation. Self-supply sources have a huge role to play in terms of water security. Example: Households in Njombe area, Tanzania, reported that thanks to their Self-supply water sources, which are provided with a Rope pump, they can generate an additional income of several 100 US\$/year, which helps them to pay back loans which were taken for the investments (Maltha 2016).</li> </ul>
Demand driven / empowerment	<ul style="list-style-type: none"> <li>The number of Self-supply systems is growing in many countries as people see the benefit and start investing in their own sources.</li> </ul>

### 3 Supporting Self-supply – why it is needed and how it works

#### 3.1 What is “Supported Self-supply”?

**Supported Self-supply** is a service delivery approach which enables households and local actors to improve the quality and quantity of water delivery service by providing **specific support mechanisms**. Such support mechanisms could include services such as information of key actors (e.g. local leaders), promotional activities, technical development and piloting of technologies and products, developing capacities of the local private sector, support of households and providers in financing, as well as coordination and sharing.

Supported Self-supply is a powerful service delivery approach which can help government and other key stakeholders to improve access for those communities which might not be covered through communal supply in the medium term (IRC 2012). In the past 5-10 years, Supported Self-supply has received more attention and recognition within the rural water supply sector as being a viable complementary service delivery approach besides the communal and centralised water supply approaches. However, there still is need for establishing a better understanding of the concept and its performance, potentials and limitations. Ultimately, there is need for wider acknowledgement and adoption of the approach by donors and government.

## ACCELERATING SELF SUPPLY

### Progress in accelerating Self-supply

#### 3.2 Need for providing support services to improve Self-supply

To achieve a higher level of service by household investments and to improve quality of water service, specific coordinated external support is needed. Without targeted external support, particularly in remote rural areas, the households will lack access to information on suitable technical options and to affordable financing mechanisms, and there will be insufficient capacity of the local private sector, which has the potential and skills to offer appropriate products and services and to establish a viable business. The need for support of Self-supply is particularly high in remote rural areas, e.g. in SSA, where at the moment, the population density is rather low and the level of socio-economic activities is insufficient to build up the critical mass to kick-start development of a market. However in economically more vibrant regions, e.g. in Latin America or South Asia, where the economy is better developed or there is a very high population density, there is more potential for the local private sector to pick up the opportunity even with little or no external support. Apart from population density and level of economy, the level of water scarcity will also largely influence the demand for Self-supply and the need to provide support services (see Figure 4).

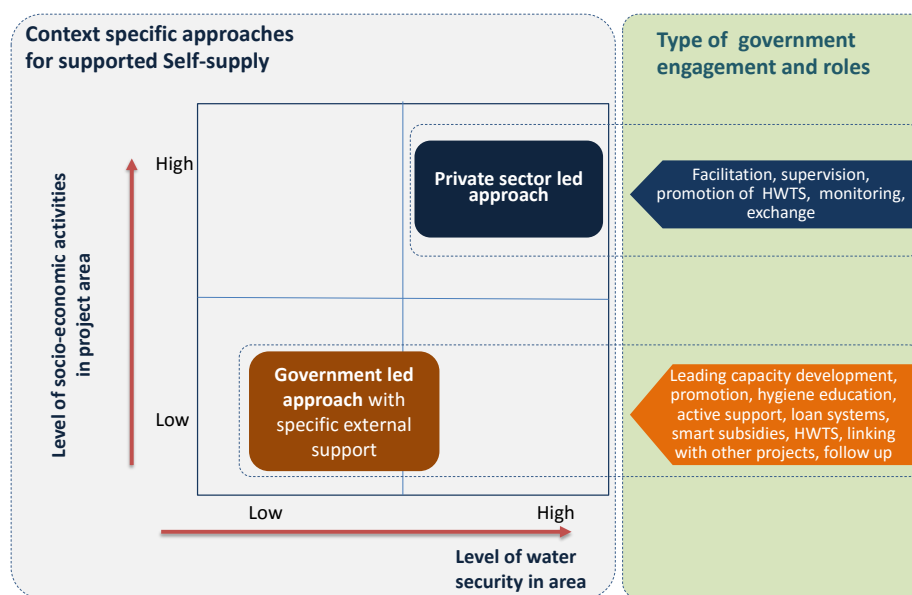

Figure 2: Different approaches used for supporting Self-supply

#### 4 Uptake of “Supported Self-supply” as a service delivery approach so far

As yet, Supported Self-supply has been taken up by some actors and some countries. However it still is not adopted on a large scale and is not integrated in many national strategies. This is one key reason why Self-supply water sources have not been considered in national monitoring systems so far. Little is still known at national level on numbers, sites, type and condition of Self-supply water sources. Furthermore, systematic monitoring of water quality, sharing and learning and follow-up are hardly done. However, despite the lack of detailed data on Self-supply sources and on the level of Supported Self-supply, there are some indications and inspiring examples where governments or other stakeholders have decided to support Self-supply actively by including specific support services in their water supply strategies and related financing plans and budgets:

- In Ethiopia, Self-supply is rolled out at national level as one formally endorsed service delivery model for rural water (see [www.ircwash.org](http://www.ircwash.org); MoWE 2014). Support services provided include promotion of the approach, capacity development of local producers of the rope pump, support of a loan scheme to allow families to purchase a Rope pump or facilitation of exchange meetings<sup>122</sup>.
- In Zimbabwe, the Upgraded Family Well (UFW) programme has been launched as a government approach for improving access to water in rural areas. Support services included promotion and information of the approach, capacity development of local masons and some in-kind subsidies for

<sup>122</sup> <http://www.jica.go.jp/project/english/ethiopia/004/index.htm>

## ACCELERATING SELF SUPPLY

### Progress in accelerating Self-supply

those families who have dug their well using their own investments of up to 300 US\$/well. Between 2000, when the subsidy scheme and external support stopped, and today, up to 130,000 wells have been improved, providing water to more than 3 million people in rural areas. This example shows real large scaling up of the approach at national level.

- In Sierra Leone, according to official national strategies for water supply, communities with less than 150 people actually have to rely on Self-supply to improve access to water<sup>123</sup> as public investments are not sufficient to improve access in the mid-term future. Currently, several international NGOs (e.g. Welthungerhilfe) and national entities are developing approaches to improve capacities for Self-supply at local level.
- More governments in SSA have formally included Self-supply in national strategies, such as Uganda and Mali but have not started bigger implementation projects (MWE 2010, Sutton 2011, Sutton 2015).

In other countries, such as Tanzania or Malawi, government has just started to acknowledge some low-cost technologies such as Rope pumps. There, the local private sector and NGOs are actively driving activities which aim to foster the capacities of the local private sector for providing low-cost WASH services e.g. in manual drilling of boreholes, in producing rope pumps, and in selling household water treatment products.

- Recent research on the impact of the SMART Centre SHIPO in Njombe, Tanzania shows that through the trained workshops, up to 5,000 Rope pumps have been produced and sold to households already. The functionality rate of household owned rope pumps is 92%, which is thanks to strong ownership by users, good maintenance and availability of local supply chain. One triggering factor for the large uptake of Rope pumps in that region is the fact that most pumps are used for domestic and productive purposes. The national agency for vocational training VETA just has adopted the Rope Pump and will include the Rope Pump in its curriculum.
- The SMART Centre approach ([www.smartcentregroup.com](http://www.smartcentregroup.com)) offers capacity development and acts as a business incubator. Specific training is provided for the local private sector, and certification systems have been introduced to ensure quality of products and services. To allow rural families to purchase the service provided by the trained masons, specific financing schemes are offered (see [www.shipo-tz.org](http://www.shipo-tz.org)). So far, the SMART Centre approach has focused on rural areas with some small towns where there is sufficient demand and capacity to establish a viable supply chain. Similar approaches are followed by other NGOs such as Welthungerhilfe and EMAS.
- In Kenya, specific WASH credits were successfully provided offering tailor-made microfinance products which are linked with purchasing specific affordable WASH products, e.g. plastic tanks provided by the local private sector (Gupta and Labh, 2016).

It needs to be emphasised that Self-supply solutions and related support services might not be applicable in all contexts due to physical and hydrogeological limitations. However, in many countries in SSA, e.g. in Zambia or Zimbabwe, about 50-70% of the people living in rural areas could be served by Self-supply sources.

### How can Self-supply be supported, and what are roles of actors involved?

#### Roles of actors in supported Self-supply

Self-supply and its support services should follow the logic of a market-based approach. The support services strive to strengthen the demand and the supply side as well as the enabling environment (see figure 3).

<sup>123</sup> <http://www.washlearningsl.org/rural-water-supply-and-small-towns-strategy-document/>

## ACCELERATING SELF SUPPLY

Progress in accelerating Self-supply

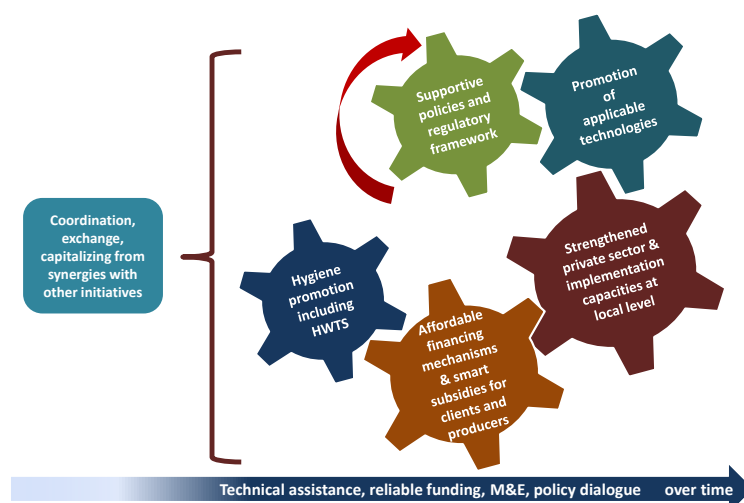

Figure 3: Core elements required to support Self-supply

It is important to realise that supporting Self-supply, as is the case with any other market development activity, needs time to establish and requires reliable funding (Olschewski, van Donk, Maillo, 2015). Monitoring and steering of programmes need to consider that decisions for investments and performance of service delivery are driven by households and the local private sector, hence more adaptive M&E and management approaches are needed.

Compared to conventional communal supply approaches where water infrastructure is often planned, provided and funded fully by government agencies or donors, the planning process and funding flows and roles in Supported Self-supply are different as the improvements are demand-driven and based on a market interaction between owners and the local private sector. Support organisations such as local NGOs or local utilities play an important role as facilitators in the initial stages of this acceleration process as they provide e.g. capacity development of the local private sector and offer financing services for rural households to invest in WASH (see Figure 4).

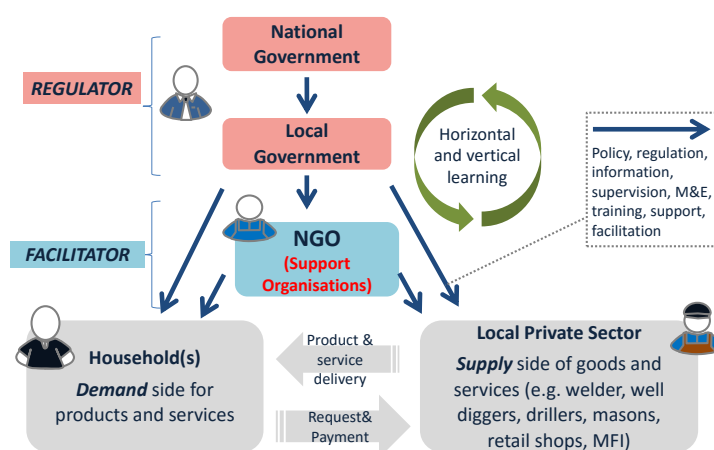

Figure 4: Roles of actors involved in supported Self-supply

Table 2: Example of principal stakeholder roles in supported Self-supply

	Government roles	Government/ NGO roles	Civil society/community	Private sector (p/s)	Owner / User
<b>Organisation</b>	- Ministries for water, health, community development, agriculture, & local government - (Local Government)		- Communities, households - WASH committees	- Area pump menders, well diggers, masons,	- Households, families, persons



## ACCELERATING SELF SUPPLY

### Progress in accelerating Self-supply

				pump manufacturers	
<b>Technical Elements</b>	-Prioritising areas -Setting standards -Technical research -Advisory services	-Training materials -Training. -Ensuring supply chain	-Technology choice -Maintaining supplies -Seeking better service -Adopting HWTS	-Offering new technologies -improved services/skills -Quality spares provision	-Informed choice on options
<b>Financial</b>	-Budgeting indirect support services -Seed funds for MFIs	-Establishing or incorporating local MFIs	-Community savings schemes -Investment in water	-Business development -Credit systems	-Owning means or borrowed means to pay for products and services
<b>Private sector</b>	-Entrepreneur accreditation -Social marketing	-training LG -training p/s -marketing strategies	-Using qualified artisans -leading by example	-Service association -Creating competition	-Client of local private sector
<b>Policy</b>	-Enabling policies, -Expanding staff roles -Subsidy rules -Tax incentives to p/s -Law and Order	-Advocacy to politicians -Strategies for marginalised /vulnerable	-Lobbying councillors for support	-Lobbying councillors for support	-Access to safe water / Human Right to Water
<b>M+E</b>	-WP Inventories including Self-supply -Policy re-evaluation	-Monitoring -Progress analysis -Strategy evaluation	-Information exchange	-Recording progress/problems	-Quality checks, communicating satisfaction level

The roles of actors in Self-supply are very different from the communal supply approach, e.g. government is no longer in the implementing role but acts as facilitator and regulator. To take Self-supply forward, it is important that all actors involved in providing support services take on the specific roles. This is particularly crucial to avoid competing approaches of government and other actors, as well as poor water quality and over-abstraction of water resources.

Whereas the roles of actors in supporting Self-supply might be quite clear, the way of triggering the uptake will differ very much depending from case to case and context. The process of planning and implementing programmes for Self-supply will take key stakeholders through a couple of steps which are very specific and different from planning communal water supplies (Smits and Sutton 2015). Within government, different Ministries might take on the initiative to trigger Self-supply, such as the Ministries of Health, of Water, or of Water Resources (Sutton 2015; <http://www.rural-water-supply.net/en/resources/details/662>). Implementation modalities for Supported Self-supply very much depend on the context, in particular hydrogeology, the situation concerning water security as well as the socio-economic conditions. There is no global blueprint for the setup of a Self-supply support programme.

### Potential synergies with other initiatives

To increase the impact of support services for Self-supply and to make best use of limited resources, the potential of synergies by linking closer with initiatives and programmers in the field of food security, health and hygiene promotion or employment or microfinance should be assessed and utilised. In particular, initiatives in the field of Multiple Use of Water Services (MUS) offer a great potential to offer synergies for promotion and establishing a viable supply chain for Self-supply for domestic and productive use. Support services provided for Community-approaches to Total Sanitation (CATS) should be assessed in detail, as they have similarities with water-related Self-supply. Following former research (Harvey 2011), more options are currently being explored in Zambia on how CATS and Self-supply for water could be combined.

### What are the costs for supporting Self-supply?

In a recent review on Supported Self-supply in Zambia and Zimbabwe, the costs for government to provide support services for Self-supply were calculated (Olschewski 2016). Using the cost figures of the so-called Life Cycle Cost Method the costs for achieving universal access in rural areas were calculated and compared by following the Communal Water supply approach (CWP) alone and by following a mixed approach (CWP

## ACCELERATING SELF SUPPLY

### Progress in accelerating Self-supply

and supported Self-supply where feasible). Based on the actual cost figures in these countries, the specific costs for government are about 40 US\$/cap for CWP if 250 persons are served per water point and about 10 US\$/cap for support services for Self-supply.

Another example comes from Zimbabwe, where for the Upgraded Family Wells the investment costs for the family are about 250-300 US\$/well. Only if families had dug and fully lined their well up to the top did they become eligible to access the in-kind subsidy (mostly cement, a lid and windlass), which was worth 50-60 US\$/well. This level of public investments is low (around 10 US\$/cap in Zimbabwe) compared to community water supplies (about 40 US\$/cap for the example of Zimbabwe). As shown in Figure 5, the government needs to spend less than 50% of LCC if a mixed approach is followed to achieve the SDGs in rural areas, compared to the costs if only CWP approach is followed. Parts of the reduced costs for government are covered by the households as they invest in the wells; however, the biggest parts of the reduced costs are due to the fact that in rural areas with low population density, Self-supply solutions are much more cost effective than CWP solutions which are imposed to all contexts. In remote rural areas, the costs per capita will increase exponentially where the number of population served per community water point is decreasing (see Sutton and Olschewski 2016).

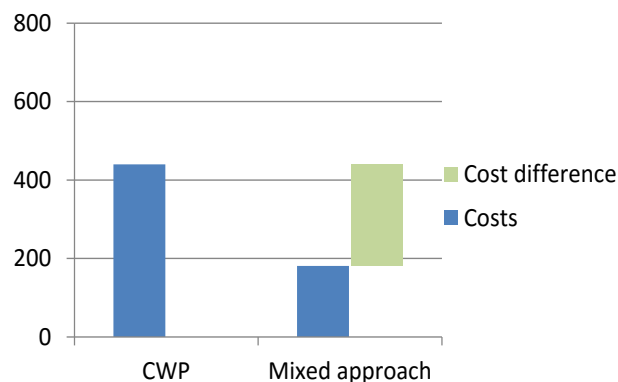

Figure 5: Costs in [million US\$] for government for achieving SDG by following two different approaches (data for Zimbabwe)

## 7 Supported Self-supply and the Human Right to Water

Readers may ask: How does the Supported Self-supply approach align with the Human Rights approach, considering the fact that domestic finances through households are quite substantial? Does Supported Self-supply exempt government from its duties to provide safe water? The short answer is: No – not at all! According to the UN Special Rapporteur on Human Right to Water and Sanitation, Dr. Leo Heller, supported Self-supply is one of the service delivery approaches which can support achieving the Human Right to Water as the Human Right to Water can also be achieved by progressive realisation (Heller 2015). In particular, the UN Special Rapporteur clarified that government does not necessarily have to provide water directly but that it has clear roles to take on to ensure universal access to safe water for all.

In the area of regulation, government might need to develop specific standards for services and technologies used at household level which may be different from standards for communal supplies. Support services provided by government might also include financial support through targeted subsidies to ensure that the very poor can also benefit from the Supported Self-supply approach. Smart subsidies may include in-kind contribution of input materials for the construction and also to stimulate market development in rural areas, as was shown in Zimbabwe. However, subsidies need to be targeted in terms of audience and purpose as well and limited in scope in order not to lead to market distortions.

### Which technologies fit the Self-supply approach?

It is important to understand that Supported Self-supply is a service delivery model and is not linked to a specific technology. Specific technologies such as manual drilling can be used for any service delivery model. Just like manual drilling is often used instead of mechanical drilling to cut costs for drilling boreholes, this could also suggest itself in Self-supply or for communal supply schemes.

## ACCELERATING SELF SUPPLY

### Progress in accelerating Self-supply

The choices of technologies which are applicable for Self-supply depend very much on the hydrogeological context, and only some technologies may be suitable in all contexts. In countries such as Zambia or Zimbabwe, where the level of use of improved sources for rural population is still very low (51% improved sources and 67 %, respectively), Self-supply could be a viable option in about 40-60% of the rural areas.

Self-supply and the technologies used in this approach are not a silver bullet which works in all contexts and might not be sufficient to provide service for all in an increasing rural population. However, apart from criteria such as applicability, there are more factors influencing uptake of technologies by households. Context specific assessments should be conducted to identify the adequate choice of technologies which are suitable as a basis of the service envisaged (see [www.washtechologies.net](http://www.washtechologies.net)).

Depending on the context, a wide range of technical options could potentially be applied in Self-supply. As most rural areas depend on subsistence farming, they have irregular incomes which might not be available as cash throughout the year. Affordability is a challenge, and social infrastructure such as MFI services are often not available. Due to lack of regular incomes, rural families are often not eligible to access loans (see for Sierra Leone: <http://www.washlearningsl.org/wp-content/uploads/2015/07/Self-supply-Financing-Report-Final.pdf>). Therefore, households mostly tend invest in low cost technologies, which can be upgraded gradually, such as:

- improving traditional wells e.g. by putting cover on or providing additional lining,
- fixing simple pumps on wells,
- installing rainwater harvesting systems and small storage tanks,
- implementing self-funded extensions of piped systems or
- using household water treatment.



*From left to right: EMAS overhead tank for shower; upgraded family well; rope pump working for 6 years; solar pump for multiple use of water*

Self-supply is not limited to a particular socio-economic context. However as some regions will benefit from social economic development, households might strive to move up the ladder faster. They will be investing in more aspirational products which provide more convenience or more benefits, e.g. solar-powered pumps for irrigation which also produce energy for housing. In these areas the local private sector will develop stronger. As in most areas, Self-supply is linked to market-based approaches, the support services will include components of market research, documentation and shared learning. In most areas, some support for

## **ACCELERATING SELF SUPPLY**

### **Progress in accelerating Self-supply**

establishing affordable financing mechanisms e.g. loan schemes will also be needed as households often struggle to pay for investment costs in one go.

### **How to deal with potential issues around water quality**

Many Self-supply water sources, particularly in SSA, use shallow groundwater. The quality of water in shallow groundwater wells can be threatened by impact of uncontrolled waste disposal, leakages from latrines or inappropriate discharge of other wastewater, and in particular by poor hygienic conditions around the well, e.g. cracks in slabs and aprons. Water sources at the lower level of the water ladder are expected to have poorer water quality than at the higher end of the ladder. Findings from recent studies actually show that unprotected shallow wells do have mixed water quality which is often of poorer quality than in so-called “improved” sources. However, these studies also confirmed that even smaller improvements of the well heads of hand dug wells lead to a major increase in water quality (Sutton, Butterworth, Mekonta, 2012).

Nevertheless, there is increasing evidence that almost all rural water supply options might be prone to risk of contamination and not all “improved” sources provide safe water. Data from a recently published review (Bain et al 2014) showed that in 38% of 191 studies > 25% of samples of improved systems, including from piped systems, exceeded the WHO standard (Bain et al 2014). The study results indicate that there is a high risk that, even in improved sources, the assumed level of safe water quality is overestimated. These findings also highlight the fact that the principle of the water ladder is valid to a certain extent (Clasen et al 2015), and that improved sources show better water quality in general than “unimproved” sources. However, the study results furthermore indicate that reaching the “improved” level is not sufficient to ensure safe water. These findings highlight the fact that, to ensure safe water, good hygiene behaviour and good management of the water source according to the principles of the “Water Safety Plan” are needed for all supplies, no matter what type of water source is involved. Hygiene education also needs to address the risks of contamination between well and point of use. The containers used and hygiene behaviour of persons involved in transportation seem to be among the major contamination sources (Wright et al 2004).

Consequently, WHO recommends including the promotion of HWTS and hygiene promotion in any rural water supply system (WHO 2015). These findings support the need to foster a multi-pronged approach for achieving access to safe water (Bain et al 2014). Future water supply strategies also have to strengthen quality measurement measures (monitoring) as well as sanitary status inspection as proposed in the Water Safety Plans and comprehensive hygiene education, e.g. along the principles of the Community Health Club (CHC) (Waterkeyn and Cairncross 2005). These soft measures are a necessary prerequisite and component of any investment project targeted to achieve SDGs. Monitoring procedures need to be adapted to include Self-supply water sources in national monitoring systems, which should allow for better follow-up progress and status of water quality.

### **Conclusion and recommendations**

There is ample evidence that Supported Self-supply offers a large potential as a complementary service delivery mechanisms and as a powerful approach to achieve full coverage to drinking water, as well as to other targets of the SDGs. Self-supply is not applicable in all regions. However, in those areas where Supported Self-supply is an option, following a mixed approach using both communal supply and Supported Self-supply will allow stakeholders to reduce costs by almost 50%. Moreover, such a mixed approach is probably the only technically and financially feasible way to gain access to the hard-to-reach, the people living in sparsely populated rural locations. However, stakeholders (in particular government entities, donor agencies and NGOs) need to take on clear roles and invest sufficient resources to ensure that Human Right principles are adhered to, e.g. to ensure that all people have access to safe water. There is no global blueprint on how to trigger and develop Self-supply, but a growing body of positive experiences is emerging, and inspiring initiatives are underway. So far, there is little understanding in the sector on the potential of Supported Self-supply and how it may be implemented. Government, donors and the local private sector should start building up more evidence-based knowhow and establish learning mechanisms to assess the context-specific potential for Self-supply and to understand how Self-supply in the different regions could be best supported and monitored. With the evidence at hand, we do not see how the SDGs can be achieved without Supported Self-supply.

## ACCELERATING SELF SUPPLY

### Progress in accelerating Self-supply

#### Acknowledgements

We would like to thank Matthias Saladin and all unknown reviewers for their thorough proofreading and for providing valuable comments.

#### References

- Alberts, H.J.H., and van der Zee, J.J. (2002): A multispectral approach to sustainable rural water supply: the role of the rope pump in Nicaragua: for: International Symposium on Water, Poverty and Productive uses of water at the household level; 21-23 January 2002, Muldersdrift, South Africa.
- Bain R, Cronk R, Wright J, Yang H, Slaymaker T, et al. (2014): Faecal Contamination of Drinking-Water in Low- and Middle-Income Countries: A Systematic Review and Meta-Analysis. PLoS Med 11(5): e1001644. doi:10.1371/journal.pmed.1001644
- Brady J, Gray NF (2010) Group Water Schemes in Ireland – Their Role within the Irish Water Sector. European Water 29:39–58
- Clasen, T.F., Alexander K.T., Sinclair D., Boisson, S., Peletz, R., Chang, H.H., Majorin, F. and Sandy Cairncross (2015) Interventions to improve water quality for preventing diarrhoea (Review); [www.theconchranelibrary.com](http://www.theconchranelibrary.com)
- Coloru, B., Mgya, S., and Rebecca Pozzi Taubert (2012) Appropriate technologies for rural water supply - A comparative study between “Rope pumps” and conventional piston pumps on water quality and other sustainability parameters <http://www.rural-water-supply.net/en/resources/details/753>
- Danert, K; Adekile, D and Gesti Canuto, J. (2014): Manually Drilled Boreholes: Providing water in Nigeria’s Megacity of Lagos and beyond; <http://www.rural-water-supply.net/en/resources/details/618>
- Gutpa, S. K., and Labh, Pr. (2016): Financing WaterCredit to enhance access to water and sanitation for attainment of SDGs; Paper submitted for the 7th RWSN Forum, Abidjan.
- Harvey P. (2011); RWSN Forum 2011. Parallels between Self Supply and CLTS: Lessons from Zambia (<https://rwsnforum.files.wordpress.com/2011/11/162-parallels-between-self-supply-and-clts-lessons-from-zambia.pdf>)
- Heller Leo: Self-supply and Human Rights – Potential and challenges; in RWSN Webinar 24.11.2015 <https://vimeo.com/147012798> <https://vimeo.com/147012798> and <http://www.rural-water-supply.net/resources/documents/default/1-748-2-1456497064.pdf>
- Hutton, G. and M. Varughese (2016) The costs of meeting the 2030 Sustainable Development Goal Targets on Drinking Water, Sanitation and Hygiene, World Bank. <http://documents.worldbank.org/curated/en/2016/02/25886252/costs-meeting-2030-sustainable-development-goal-targets-drinking-water-sanitation-hygiene-summary-report>
- Maltha, A (2016): Accelerating Scale up of SMARTechs for water in Tanzania, using a market based approach; 30.1.3016. ([http://www.shipo-tz.org/files/scale\\_up\\_of\\_smartechs\\_tanzania\\_jan2016.pdf](http://www.shipo-tz.org/files/scale_up_of_smartechs_tanzania_jan2016.pdf))
- MWE (2010): Strategic Framework on accelerating Self-supply, Uganda.
- MoWE (2014): Manual for Accelerating Self Supply. Water Supply & Sanitation Directorate, Ministry of Water, Irrigation and Energy, Addis Ababa, Ethiopia ([http://www.rural-water-supply.net/\\_ressources/documents/default/1-628-2-1413877896.pdf](http://www.rural-water-supply.net/_ressources/documents/default/1-628-2-1413877896.pdf))
- Olschewski, A. (2016) Synthesis report - Review of support Self-supply; for UNICEF ESARO <http://www.rural-water-supply.net/en/resources/details/753>
- Olschewski A., van Donk M., Mallio J. (2015): Innovative mechanisms for improving Self-supply services: <http://wedc.lboro.ac.uk/resources/conference/38/Olschewski-2287.pdf>
- RWSN (2015): Webinar series on Self-supply and Human Right to water (<http://www.rural-water-supply.net/en/resources/details/670>; <https://vimeo.com/147012798>)
- Saladin, M (2016): Rainwater harvesting in Thailand: Learning from the World Champions. RWSN field note 1-2016. <http://rural-water-supply.net/en/resources/details/759>

## ACCELERATING SELF SUPPLY

### Progress in accelerating Self-supply

- Shields, K., Bain, R., Cronk, R., Wright, J. and Bartram, J. (2015): Association of supply type with fecal contamination of source water and household stored drinking water in developing countries: a bivariate Meta-analysis; in: Environmental Health Perspectives; Vol 123, No 12, December 2015.
- Smits, S and Sally Sutton (2015) the case for leveraging greater household investment in water supply [http://www.ircwash.org/sites/default/files/084-201502triple-s\\_bn03defweb\\_1.pdf](http://www.ircwash.org/sites/default/files/084-201502triple-s_bn03defweb_1.pdf)
- Sutton, S. (2011) Accelerating Self Supply –Summary of progress in introducing a new approach; RWSN fieldnote 2011-2 ([http://www.rural-water-supply.net/\\_ressources/documents/default/241.pdf](http://www.rural-water-supply.net/_ressources/documents/default/241.pdf))
- Sutton, S., Butterworth, J. and Mekonta, L. (2012): A hidden resource: household-led rural water supply in Ethiopia. IRC International Water and Sanitation Centre, The Netherlands.
- Sutton, S. (2015): Towards universal coverage – Self-supply as part of the solution for the hard-to-reach in Zambia; paper presented at 39<sup>th</sup> WEDC 2016, Kumasi, Ghana.
- Sutton, S. and Olschewski, A. (2016): **Supported Self-supply – the option to achieve SDGs**; Paper submitted for the 7th RWSN Forum, Abidjan.
- Waterkeyn, J. & Cairncross, S. (2005). Creating demand for sanitation and hygiene through Community Health Clubs: a cost-effective intervention in two districts of Zimbabwe. 61. Social Science & Medicine.1958-1970
- WHO (2011): Small-scale water supplies in the pan-European region [http://www.euro.who.int/\\_data/assets/pdf\\_file/0018/140355/e94968.pdf](http://www.euro.who.int/_data/assets/pdf_file/0018/140355/e94968.pdf)
- WHO (2015): WHO Ethiopia (2015): Is household water treatment and storage part of the answer to safe water supplies? YES! [http://www.rural-water-supply.net/\\_ressources/documents/default/1-662-2-1428938050.pdf](http://www.rural-water-supply.net/_ressources/documents/default/1-662-2-1428938050.pdf)
- Wright, J; Gundry, St. and Conroy, C. (2004): Household drinking water in developing countries: a systematic review of microbiological contamination between source and point-of use; in: Tropical Medicine and International Health; Vol. 9 No 1 pp 106-117.

## Annex

### Practical field tested resources exist to support future Self-supply initiatives

There are already quite a lot of resources available in the public domain or at low cost which can be used to plan and guide through a programme for supporting Self-supply. A set of guiding blocks is presented for both contexts which are suitable in different contexts, the more government- led approach and the more business-led approach (Olschewski 2016). Apart from this there is a wealth of literature on specific technologies, on financing approaches and, increasingly, on business models. Three particular tools are shared here which were developed or updated recently:

- Ethiopia: manual for Accelerating Self-supply (Ministry of Water and Energy, 2014): [http://www.rural-water-supply.net/\\_ressources/documents/default/1-628-2-1413877896.pdf](http://www.rural-water-supply.net/_ressources/documents/default/1-628-2-1413877896.pdf)  
(guidance for different steps of scaling up Self-supply)
- WASHTech (2013): Technology Applicability Framework (TAF): [www.washtechtechnologies.net](http://www.washtechtechnologies.net) (field-tested method to assess applicability and scalability of specific WASH technologies) including guidance document on Technology Introduction TIP)
- Sutton, S. and Nkoloma, H. (2003): Encouraging Change –Practical guidelines for fieldworkers (TALC Publishing)  
<http://www.talcuk.org/books/encouraging-change-sustainable-steps-in-water-supply-sanitation-and-hygiene-2nd-edition.htm>  
(practical guidelines on basic technologies suitable for low cost Self-supply interventions)

## ACCELERATING SELF SUPPLY

### Progress in accelerating Self-supply

More documentation on self-supply and support services e.g. case studies is available on [www.rural-water-supply.net](http://www.rural-water-supply.net) or in the library of the RWSN Dgroup for “Accelerating Self-supply”.

## ACCELERATING SELF SUPPLY

Progress in accelerating Self-supply

---

# Establishing a baseline for Self-supply Acceleration in seven Ethiopian woredas

---

Type: Long Paper

**Authors** John Butterworth (Country Director, IRC Ethiopia, [butterworth@ircwash.org](mailto:butterworth@ircwash.org), +251969119395), Lemessa Mekonta and Bethel Terefe

### Abstract/Summary

*This paper discusses research to establish a baseline for a Millennium Water Alliance-supported pilot to test approaches to Self-supply Acceleration in rural Ethiopia. Key findings from the baseline study which covered seven targeted woredas (districts) in Amhara and Oromia regions are summarised, and recommendations for implementation and follow-up monitoring are discussed. A key recommendation is to focus on promoting the upgrading of existing family wells. These are typically unprotected and provide poor water quality for drinking. The first assessment of an alternative group-led model to Self-supply raises important questions with respect to utilisation and cost-effectiveness of this approach, which is being widely implemented by government.*

### Introduction

Self-supply Acceleration involves public (and NGO) investment in a set of activities that are intended to trigger private household investments in new and improved water supply facilities. These facilities are typically privately-owned but often shared with neighbours. Hand-dug wells that provide access to shallow groundwater are the most common type of facility, but Self-supply technologies can also include the development and construction of other water supply sources such as springs and rainwater harvesting as well as household water treatment and storage.

Self-supply facilities may be used for drinking but are also commonly used for a range of other uses including bulk water supply for washing and sanitary purposes, watering of livestock and irrigation. They may be used by some households as the sole water supply, or in conjunction with other water sources such as community water supplies. Characteristics of existing Self-supply facilities in rural Ethiopia are described in more detail by Sutton *et al.* (2012) and Butterworth *et al.* (2013).

The Ethiopian government set out its policy to support Self-supply in 2012 (MoWIE, 2012) and the One WASH National Programme (OWNP) includes Self-supply projects as one of its four service delivery models for rural water supply (MoWE, 2011). Two kinds of Self-supply are recognized. Group-led Self-supply involves small groups of households coming together to develop a joint facility, and these may be subsidized up to 50% of the capital investment costs. Household-led Self-supply involves individual private investment in water supply facilities and the capital investment costs are not to be subsidized.

The Millennium Water Alliance (MWA) is supporting the development of improved water supplies through both the group-led and household-led investment models. While the original intention was to give more emphasis to piloting and providing a proof of concept of a Self-supply Acceleration approach to help drive household investment, the early focus of MWA implementing partners was put on the group-led Self-supply model. This is rather similar to existing forms of community water supply so is easier for NGOs and government to implement within their existing capacities. However, supporting household-led investment requires market-orientated interventions to build supply and demand that are more similar to aspects of sanitation marketing or household water treatment. Such approaches are novel within the rural water sector which lacks a tradition of working directly with individual households.



## ACCELERATING SELF SUPPLY

### Progress in accelerating Self-supply

The Self-supply Acceleration approach being tested by the MWA is set out in a series of guidelines developed with the participation of MoWIEs Self-supply task force and consistent with MOWIEs Self-supply manual (IRC, 2013; MoWIE, 2014). The aims of the MWA pilot are:

- 1) To provide proof-of-concept of a Self-supply Acceleration approach to trigger and support household-led investments in improved water supplies
- 2) Active water credit programs in each of the seven woredas, with at least 1100 loans extended to support Self-supply investments
- 3) A strengthened local private sector servicing Self-supply, with at least 2 businesses in each woreda providing new or improved products or services
- 4) To reach 35000 people with improved water supplies<sup>124</sup> through household-led Self-supply (investments in 1400 new or upgraded wells).

### Context, aims and activities undertaken

This paper discusses research to establish a baseline for the MWA pilot in the seven targeted woredas in Amhara and Oromia regions (see Figure 1). The objectives were:

- 1) To provide a baseline of existing Self-supply facilities and their performance against which the achievements of the Self-supply Acceleration pilot can be assessed.
- 2) To provide information for the planning of Self-supply Acceleration activities in the pilot woredas.
- 3) To encourage engagement of critical stakeholders in Self-supply Acceleration and to strengthen their skills and knowledge.

Initially the focus was on household-led investments, although the baseline was extended to address the group-led model as it emerged that this was becoming an important area of programming for the partners. The objective here was:

- 4) to document how the group-led approach was being implemented by MWA partners and to assess its cost effectiveness and service levels.

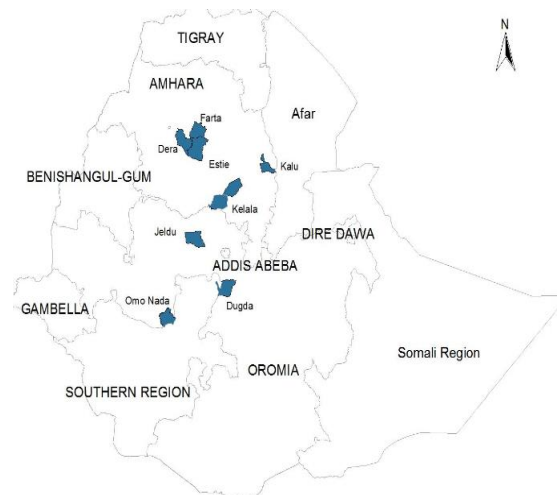

Figure 1: Location of woredas for MWA-EP pilot Self-supply acceleration activities

The baseline survey was intended to provide a basis to be able to answer the following questions at the end of the Self-supply Acceleration pilot i.e. in mid-2017.

- How many privately owned Self-supply facilities were constructed or improved during the project timeframe, and how many people benefited? To what degree (level of technology, level of protection)

<sup>124</sup> Through the group-led model it is also expected that 20000 additional people will be provided with access to improved water supplies.

## ACCELERATING SELF SUPPLY

### Progress in accelerating Self-supply

- were facilities built or improved? *The revised target is to trigger improvement of 1400 sources serving 35,000 people (i.e. assumption that wells are shared by on average by 25 people).*
- How has microbial water quality (E coli) changed during the project timeframe and can this be related to project interventions? *The target is ultimately zero or low risk water supplies, but the interest is to show whether Self-supply Acceleration can achieve progressive improvements and narrow the gap in water quality performance with communal supplies.*
  - How much public/NGO investment has been made in Self-supply Acceleration, and how much household investment has been leveraged by this investment? *Anticipated investment might be in the range USD10-20 per capita within the targeted kebeles, and be expected to leverage double that investment by households.*
  - How many households have taken MFI loans or used other sources of finance to make these investments? *The target is uptake of 1100 loans.*
  - What is the degree of engagement of private sector businesses in providing products and services for Self-supply? *The pilot aims to increase the number of businesses offering goods and services of different types related to Self-supply (well digging/ drilling, protection, pumps, HWTS etc.), and support the growth of these businesses and the markets served. The target is at least 2 strengthened businesses operating in each woreda.*

Five data collection instruments were developed: 1) a household survey for households with existing Self-supply facilities with questions on well characteristics, lifting devices, hygiene & sanitation, well performance/reliability, use, satisfaction, sharing and interest to improve, with water quality assessments using the compartment bag test for E.coli contamination for a sub-sample of facilities, 2) an enterprise survey for businesses providing WASH products and services, 3) a financial institution survey for MFIs, 4) key informant interviews guided by a checklist with questions on water supply, local businesses and finance, and a wealth ranking assessment to identify locally relevant categories for relative wealth ranking of households responding to the household survey, and 5) a group-led Self-supply survey.

Data was collected using smartphones and the Akvo Flow data collection app, using the monitoring functions available to design the surveys to facilitate easy repeat survey of the same facilities. The surveys used are available at [www.ircwash.org](http://www.ircwash.org).

In each woreda (district), priority kebeles (a sub-district unit) for Self-supply Acceleration had already been identified by partners on the basis of their potential (including availability of shallow groundwater resources). The numbers of prioritised kebeles was in the range 1- 6 for the different woredas. Where the number of existing household level facilities in these kebeles was considered manageable e.g. up to 50-100 per kebele, all facilities were then visited, mapped and the household survey administered. Where the number of existing sources was too high in a prioritised kebele (this was only the case in Dera), village(s) with the most potential for Self-supply were selected and all facilities in those villages were surveyed. However, this sampling procedure was not followed in the case of Kalu woreda where all the Self-supply facilities were household rainwater harvesting ponds. In the selected kebeles, the survey was stopped when 500 ponds had been surveyed.

Water quality tests were taken for every 10<sup>th</sup> Self-supply facility surveyed, using the next facility as a replacement in cases where water could not be obtained from the source.

The total number of household self-supply facilities surveyed was 2161, with 209 samples taken for water quality tests.

Key informant interviews with local officials and professionals were used to collect information on the estimated number of Self-supply facilities as well as the presence of relevant business types and financial institutions active in the woreda. A snowballing approach was then used to extend the list of businesses and financial institutions with the simple survey administered to each.

## ACCELERATING SELF SUPPLY

### Progress in accelerating Self-supply

The survey of group-led facilities included 25 facilities constructed in Dera, Este and Dugda woredas by CARE and MCS/CRS. Follow-up assessment on costs of construction and sharing of investments however used data from 58 group-led Self-supply facilities implemented by MWA partners, including those not included in the survey, from Farta, Dera, Este and Dugda woredas.

As far as possible, data collection was undertaken by woreda officials with relevant roles in water supply. The intention was to promote ownership and understanding of the data collected, support development of their skills and knowledge and encourage further involvement in Self-supply planning. In each woreda, the lead NGO partner set up the survey with local government officials with the support of IRC and the MWA. There was some variation between woredas in the way the survey was implemented and recruited enumerators were used instead of government staff in two woredas.

The next sections of the paper present some of the key findings of the baseline survey, and discusses lessons learned and experiences in monitoring Self-supply that are potentially relevant to other countries and efforts, as well as monitoring Self-supply nationally.

### Main results and lessons learnt

#### *Investors in Self-supply*

The survey assessed the profile of households owing Self-supply facilities with respect to wealth, education and gender. This is a major concern of government and agencies supporting Self-supply as an approach. Households in all wealth categories have wells or other facilities, although the majority of the households (80%) in the survey categorized themselves as belonging to the middle wealth group. Education levels amongst facility owners are generally low. Well ownership amongst female-headed households is very low. Only 9% of the facilities (194) are owned by women or female-headed households, which is 2.5 times less than would be expected extrapolating from statistics on expected numbers of female-headed households. Compared to male-headed households, more female-headed households also fall in the poorer wealth category and less belong to the richer households.

Investment in Self-supply facilities is influenced by wealth. Taking the level of well protection as a proxy indicator for total investment and excluding those households who have received subsidy, ownership of a better protected well (semi-protected) is more common among the better off households (Figure 2). Compared to poorer households, better off households have also made more investments in construction materials, simple lifting devices and lining for ponds, while poor households invested more in local materials and labour. Ongoing improvement of wells is also slightly more common among the richer households.

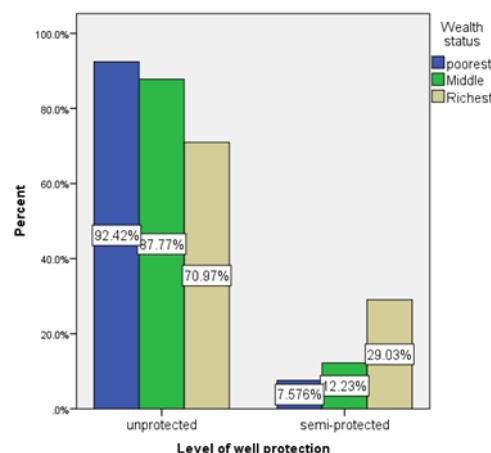

Figure 2: Level of well protection by wealth category

## ACCELERATING SELF SUPPLY

### Progress in accelerating Self-supply

Only 23% of the wells owned by female-headed households fell into the semi-protected category, while the corresponding figure was 36% for wells owned by male headed households, indicating a bigger gap in investment and improved management of wells among female headed households.

Levels of mobile phone ownership amongst well owners are high and phone numbers were collected during the survey so there is potential to contact owners by phone or messaging e.g. to send promotional messages or ask follow-up questions.

#### *Investments in Self-supply*

Although households have all made some investment in construction of their wells or other facilities, these are generally low-cost facilities requiring limited capital. Most of the facilities (70%) were constructed by households using their own labor or the support of friends and neighbors without payment. Less than one fifth (18%) hired skilled local artisans. Where households purchased products during construction of the facilities, which was true for 82% of the cases, half of the products purchased are locally available materials like a rope and bucket or simple lifting devices, such as pulley or windlass. Very few, purchased construction materials like cement, or low-cost pumps like rope pumps. Kalu is the only exception where households commonly paid for the lining (a specialised material) of ponds used for irrigation.

Ongoing improvement and maintenance and of Self-supply facilities also involve low capital investments. The most common ongoing maintenance across the woredas was the cleaning of wells and ponds (44%), while very few cases of maintenance of lifting devices and pond linings are reported. About a third (36%) of the households have not made any maintenance at all. Some 30% of well owners made improvements to their Self-supply facilities, mostly in Dera and Omonda. The most common type of improvement is deepening of wells in Dera driven by expanding irrigation for chat production and increasing demand for water, and upgrading of lifting devices in Omonada.

The survey indicates a significant proportion of the households 76% have aspirations for future improvement of wells, which might also indicate willingness to invest. Most want to improve the head work of their wells including well mouth cover and slab; upgrade lifting devices to higher levels of technology and some want to improve well lining.

#### *Use*

Self-supply facilities are used for multiple purposes by households. Domestic sanitation and hygiene uses (cleaning, washing and bathing) and livestock watering appear are the most common uses. Many wells (but not the ponds) are also used for drinking water supply. 37% of hand dug wells (i.e. excluding ponds) are used for drinking and family wells are the main source of drinking water supply for about 36% of the households surveyed (other households rely on community water supplies). About 45% out of the total hand dug wells are used for irrigation. Irrigation use is more prominent in woredas like Dera and Kalu (where ponds are the main Self-supply facilities) and is less common in other woredas like Omonada and Dugda. In the former, most households grow cash crops like khat, coffee or fruits and vegetables using water from household wells or ponds to bolster their household income. The highest annual cash benefits from irrigation are obtained by households in Dugda, Kalu and Dera woredas.

Although Self-supply facilities are privately owned, the benefits are often spread wider. Out of the sample, 58% of well owners share their Self-supply facilities with other households. Most share with less than 5 households while about 35% may share with up to 10 other households. Sharing is more common in Omonada, Kelela and Dugda, while it is less practiced in Dera where individual well ownership is very high and many households have more than one well. Sharing households mostly use the water for drinking water supply or sanitation and hygiene uses.

Overall, the majority of Self-supply facility owners (88%) are satisfied with their facilities. Satisfaction levels are highest in Dera, Kelela and Kalu woredas. Satisfaction with Self-supply facilities appears to be highest in cases where households are able to use the water for irrigation.

## ACCELERATING SELF SUPPLY

### Progress in accelerating Self-supply

#### *Safety*

Latrines are relevant since they help families maintain good hygiene and they are constructed through similar promotion and household investment mechanisms as Self-supply. They may also present risks if located too close to wells. Amongst Self-supply facility owners, ownership of latrines is high overall, with about 84% of households in the survey having access to latrines. However, there are differences across woredas and relatively a higher proportion of households are without access in Dera and Dugda woredas. Most (74%) of the latrines owned by households are basic being pits without a cleanable slab. Open defecation is used by households without latrines. Given large distances between households, sharing is not common.

Household water treatment is practiced by very few households. From households that use their Self-supply facility for drinking water, only 12% use a filter, chemical treatment or boiling before drinking. This is consistent with other studies such as for the National Hygiene and Sanitation Strategic Action Plan (2011- 2015) where 8% is the estimated level of HWTS practice in the country.

Water quality tests (for E.Coli contamination) showed the majority (76%) to be contaminated with unsafe levels of E.coli, more than 10MPN/100ml [Figure 3]. This is consistent with other water quality surveys of traditional wells. Sutton et al. (2012) reported 80% of unprotected wells to exceed 10 TTC/ 100 ml (a slightly different indicator) and 69% of semi-protected wells with a drum (a common form of wellhead protection). The highest water quality risks are observed in Dera and Dugda woredas followed by Este and Farta. Lower levels of contamination are observed in Kelela. Here, all of the wells sampled were semi-protected (rope pumps), having been built by NGOs. However, overall the risk profile of semi-protected and unprotected wells is similar. Other studies (Sutton et al., 2012) have shown noticeable improvements in quality even with limited protection.

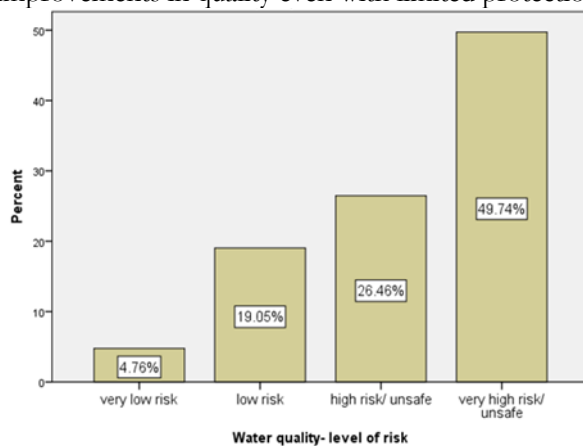

## ACCELERATING SELF SUPPLY

### Progress in accelerating Self-supply

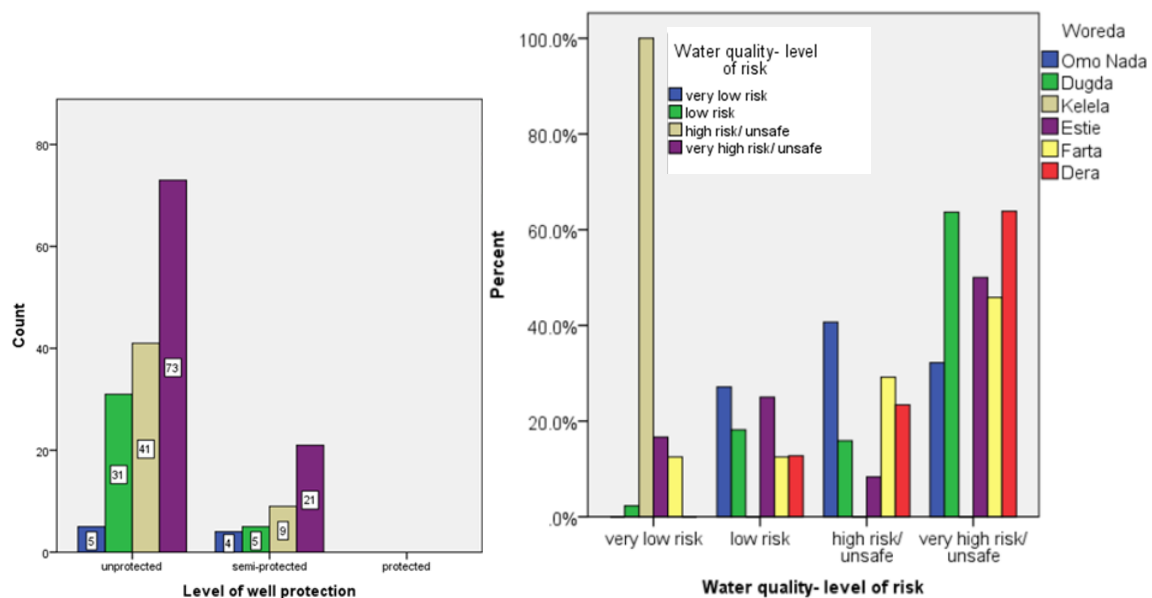

Figure 3: Microbial contamination (*E. coli*) levels for hand-dug wells a) all wells by risk group (very low risk = 0 MPN/100ml, low risk 0-10, high risk 10-100, very high risk >100), b) numbers of wells by category of protection and risk group, and c) risk group by woreda.

#### Local markets

As discussed above, there is an existing market for the products and services needed by households to develop their Self-supply facilities. However, use of own labour is preferred and investments are typically in low-cost and locally-available items. There is clearly potential to grow the size of the market for improved services and products from its current level if these can be made available and marketed. The survey also examined the presence and status of local enterprises that currently service this market or are engaged in related business sectors.

The number of enterprises identified in the targeted areas was fairly limited and most are informal enterprises. In most of the woredas there were a few businesses (1-3) engaged in relevant business sectors such as local fabrication of steel products (so they could make pumps, or windlasses) but generally they are not making Self-supply related products. This was the case in Kelela for example. In other woredas there are enterprises servicing pumps (treadle pumps in Kalu, engine pumps in Estie and Dera). In Dugda, 19 business enterprises were identified that provide services and or products related to WASH, most of them informal or unregistered. These include businesses supplying well construction materials and latrine slabs, some selling water treatment products, some supplying storage tanks and other manufactured lifting devices such as pulleys and rope pumps. The pharmacies (selling point of use treatment products) and metal works are registered businesses but all others are informal. In Omo Nada, eight enterprises were identified. Most of these are servicing community water supplies such as providing spring development and hand pump installation services.

According to the baseline survey, lack of investment capital, working space, equipment, locally available spare parts, communication about their products and /or services and administrative issues such as licensing are among the major challenges of the private sector and its development.

#### Financing

External financing for household Self-supply investments is virtually absent in the seven woredas. The majority of households (93%) have used their own resources for investment in construction and upgrading of facilities. Very few (3%) have received subsidies from government or NGOs (the rope pumps in Kelala was one exception) working in the woreda, and almost no households (0.4%) report they have received loans from either Micro Finance Institutions (MFIs) or rural saving and credit cooperatives

## ACCELERATING SELF SUPPLY

### Progress in accelerating Self-supply

for Self-supply investments. The share of informal saving and credit groups in financing household Self-supply is equally very low. The results are similar across different wealth groups and female and male headed households. Comparing results across the seven woredas, subsidies appear to be higher in Kelela, reaching up to 55% and in Este 13% of households. Subsidies may be higher in Dugda, where the households partial contribution for rope pumps provided by an NGO was not well captured in the survey.

Despite the currently low level of financing to household Self-supply, there are opportunities that can be tapped. In all the woredas, micro-finance institutions are present and providing loans to households. One MFI, Amhara Credit and Saving institution (ACSI) has opened several offices in four of the woredas: Dera, Farta, Este, Kalu and Kelela. In Dugda there are 4 privately owned MFIs and one government MFI, while in Omonada there are 1 government and 1 private MFI. While the majority of MFIs lack experience in provision of water loans, ACSI has been providing water loans, mainly for motor pumps and pipes used for irrigation. The conditions of loan provision by ACSI have slight differences across woredas. The maximum loan size provided for rural households is up to Birr 50,000 depending on the applicants loan history. The conditions required for loans are usually either group guarantee or guarantee by woreda government and the profitability of the venture. Farmland is sometimes also taken as collateral. Loans are provided on annual interest rates ranging from 13-18%, with a total loan repayment period with in 2 or 3 years.

Overall there is interest by the MFIs to engage in loan provision for Self-supply, though some caution is also observed. In Dugda and Omonada, the MFIs have not entered into water loan provision because they consider it as a risky investment, though they have shown interest in the survey. In Amhara region, ACSI, while it has experience in water loans is cautious about loan provision to Self-supply which doesn't include engagement in productive use of water.

#### *Group-led 'Self-supply'*

According to national policy guidelines, the group-led Self-supply model is expected to be driven by households with at least 10 or more households coming together in a group to qualify for a subsidy. However, in the case of the three woredas concerned (Dera, Estie and Dugda), the initiative for the group investment has commonly come from the woreda government or NGOs operating in the woreda some of the time, while only in a few cases have the group members made a request. The groups' involvement in managing the finance and construction is weak in almost all cases.

The system of management, tariff setting and fee collection, as well as size of the group members varies according to the type of technology used: Afridev hand pumps in Dugda, rope pumps in Este and pulleys in Dera. A managing committee is set up for Afridev hand pumps, while one person is assigned to manage rope pumps. No management arrangement is made for upgraded facilities with pulley. Flat household tariffs are set for facilities with Afridev hand pumps, while there is no regular fee collection system for facilities where a rope pump or a pulley is used. The size of the group varies from 21 households on average for Afridev hand pumps in Dugda to less than 5 households for rope pumps and pulleys.

Most of the group-led facilities have been constructed in the past two years by NGOs with contributions of group members in the form of labor, local construction materials such as sand and stone, and in some cases money for purchase of construction materials or a deposit for future maintenance (amounting to up to 500 birr per group). NGO contributions included construction materials such as cement, purchase of pumps and skilled labor for construction and installation. In the case of Dugda, Afridev hand pumps are freely distributed by the woreda water office for the group-led facilities.

For the dug-wells fitted with rope pump or pulley, group members are estimated to cover more than 62 and 53% of the total cost of construction, respectively, through in-kind contributions, such as gravel, sand, stone, wood and well digging. For dug-wells fitted with hand pump, the group members' in-kind contribution amount to only 40% of the total construction cost.

## ACCELERATING SELF SUPPLY

### Progress in accelerating Self-supply

A comparison of the unit costs of group-led facilities constructed by MWA partners and the regional Self-Supply standards within OWINP, shows a disparity. The figures suggest that group-led Self-supply facilities constructed by MWA partners in South Gonder are much more expensive than national standards, raising questions about cost effectiveness and equity. On the other hand, group-led Self-supply facilities in Dugda are below national cost standards, raising questions potentially on standards of the construction. The unit and per capita costs of hand dug wells fitted with rope pumps for groups in the MWA woredas are almost double the OWINP standard set for Amhara region, while the hand dug-well with pulleys cost 40% more. On the other hand, the unit prices for Afridev hand pumps in Dugda are much lower (about half) than the standard set in OWINP for Oromia region.

Figure 4. Costs of group Self-supply facilities (in birr) and proportion covered by members and NGOs/government

Figure 5: Unit costs of group-led Self-supply facilities constructed by MWA partners and OWINP standard costs

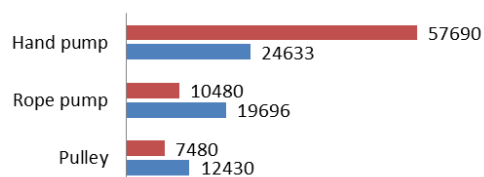
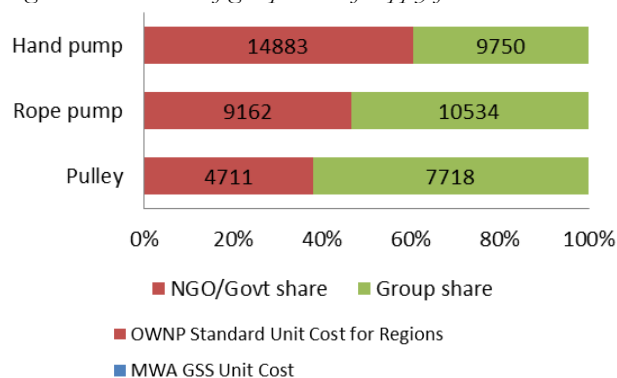

Similarly, the average per capita cost of group-led facilities shows major differences with the per capita cost standards used for OWINP planning. The per capita cost of dug-wells with rope pumps is more than double the standard per capita cost in the OWINP set for Amhara region. The difference in unit cost coupled with the difference in number of beneficiaries, which is lower for group Self-supply facilities constructed by MWA partners, has resulted in higher per capita costs. Although the costs of the hand pump schemes in Dugda was relatively low, the numbers of beneficiaries is also reduced so the actual per capita costs of these schemes is close to the proposed standard.

Figure 6: Per capita costs of Group-led Self-supply facilities constructed by MWA and OWINP standards

Figure 7: Beneficiary numbers for MWA group-led facilities and OWINP standards

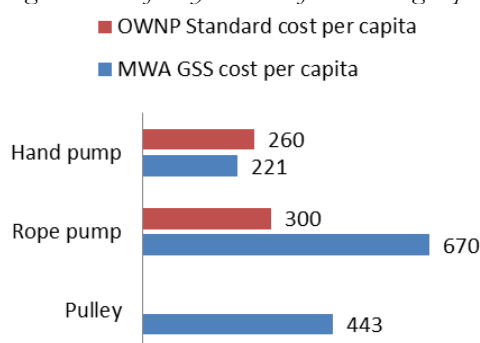



## ACCELERATING SELF SUPPLY

### Progress in accelerating Self-supply

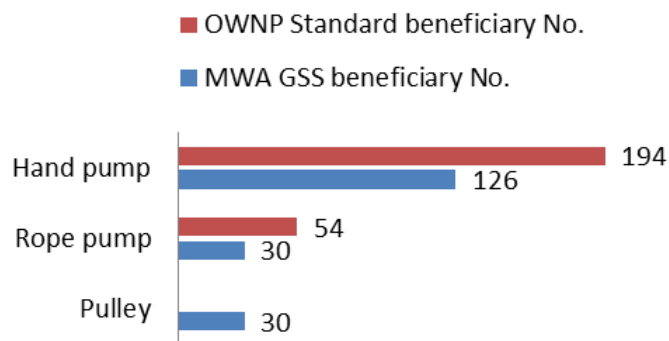

All the 25 group-led Self-supply wells surveyed were semi-protected wells with some protection intended to prevent external contamination of the well. However, unhygienic handling of rope and bucket in some cases and contamination of the immediate area around the well with solid and faecal waste are observed problems. Most of the wells are functional all year round, providing adequate water for group members and those outside of the group sharing the facility. The depth of the majority of the wells is between 10-15 meters.

The main use of water from the group-led facilities is for drinking (100%) and sanitation and hygiene purposes (96%). For more than half of the group members, the facility is their main source of drinking water. However, others favour alternative community water supplies, perhaps due to their better levels of protection. The water from group-led wells is also used for livestock (64%) and 24% of the users also use some for irrigation. Irrigation users are mostly households on whose land the facility is constructed. Half of the group-led facilities are shared with other households outside the group who mainly use it for drinking and cleaning and sometimes for livestock.

The majority of the households are very satisfied with their group facility. In more than half of the cases, there is no limit to the amount of water households can collect. However, 62% on average collect less than 15 litres of water per head per day, while 25% collect more than 15 litres but less than 25 litres per head per day. Only 12% were able to collect 25 or above litres per head per day. Waiting times at the source to collect water is very low being less than 5 minutes for 76% of the households. Very few families had to wait for above 10 minutes. Most of the respondents rated the quality of water as good for human consumption and the majority don't have any concerns about the water quality.

### Conclusions and Recommendations

- The numbers of facilities identified in the survey generally surprised local officials. Given large numbers of existing facilities, which are generally poorly protected and could be relatively simply improved, it is recommended that the MWA pilot specifically prioritises upgrading of facilities. Given the limited period available for interventions within a project approach, this offers more potential for quick wins than longer-term but still necessary interventions to introduce new technologies or build local manufacturing capacity etc. Upgrading and promoting improved management of facilities (ensuring cleanliness and safe use of lifting devices etc.) has strong potential to demonstrate improvements in water quality and reduced risk to households.
- Based on knowledge of the existing owners (investors) in household-led Self-supply facilities, it is recommended that supporting Self-supply Acceleration interventions should pay specific attention to targeting the needs of women and female-headed and poorer households to help them upgrade their Self-supply facilities.
- Most wells are used for multiple purposes including productive and domestic uses. The most common uses of water are related to hygiene and sanitation (washing). These benefits should be considered when promoting investment in wells, and strategies developed with participation of agriculture, health and other sectors.
- Levels of mobile phone ownership are high amongst well owners which could be used support promotion of upgrading.

## ACCELERATING SELF SUPPLY

### Progress in accelerating Self-supply

- Although it was originally intended, the survey did not embed the capacity within the wordas to add new facilities to the database of Self-supply facilities that were mapped during the survey, or to update the status of facilities (e.g. where they were upgraded or new water quality tests undertaken). This will now be done through the end line survey in MWA wordas. It might be possible to encourage Self-supply facility owners to register their facilities with the worda if this was related to some sort of incentive such as access to information or advisory support. This could support monitoring in the longer-term if linked to implementation activities by the wordas.
- Private sector development in all the wordas is an early stage. Supply chains for products and services related to Self-supply are not well developed but they do exist. Interventions should build on what already exists in these wordas. These service providers receive little attention or support from professionals and agencies, so there is a gap in business development services to fill. One practical step is to engage business representatives in the planning of Self-supply Acceleration interventions. Most businesses are informal and with limited capacity. Formal registration could bring advantages but also presents risks for such enterprises and individuals. Carefully designed business development strategies are needed that focus on both informal and formal businesses and try to create an improved enabling environment for the informal ones (e.g. towards registration and licensing)
- Availability of finance is not the most critical constraint to getting on the Self-supply ladder, but more finance could help owners to upgrade and improve their facilities, or construct to a higher standard. Finance might also be used to extend access by poorer households, women and women-headed households but only if interventions are designed to this objective. There is potential - if convinced about the potential viability of the market - for MFIs to support household-led investments through loans which they currently only do for ‘productive’ irrigation wells. This needs engagement with MFIs to encourage, and support to design loans and follow-up. There is also potential for MFIs to lend to businesses servicing the Self-supply market.
- Implementation of the group-led Self-supply approach among MWA partners is found to be variable. In some cases it is not in line with national standards that require 10 or more households to be in a group to qualify for a subsidy. In other cases, the partial subsidy provided by NGO and Government has exceeded the mandated limit. The type of technology promoted seems to be a critical factor in influencing the number of households in a group or the proportion of households’ contribution to the total cost. Looking at how services are initiated and implemented, Group-led Self-supply has more characteristics of community Self-supply than what is known elsewhere as Self-supply. The initiative is not strongly bottom-up and there are low financial contributions from the group members compared to household-led Self-supply. To avoid confusion, the name might be changed to something like ‘Group-led subsidised schemes’.
- Of concern, slightly more than half of the users of the group-led schemes use the the water as their main drinking source.
- With respect to cost effectiveness, the unit and per capita costs of construction of the group facilities are much higher for hand-dug wells with rope pumps and pulleys compared to national standards set for conventional community water supply. The survey raises questions on the costs of the MWA Group-led model which could be further investigated. The study did not examine government implemented group-led Self-supply schemes. A study is recommended of the government-led schemes utilising the experience that MWA now development in the assessment of the group-led approach i.e. using the same survey questions etc.
- Critically we have not yet identified any strategy on how both group-led and household-led approaches are (or can be) implemented together as part of a strategy towards universal coverage together with community water supply. This is an area where MWA also has a comparable advantage and could lead the development of practical approaches.

### Acknowledgements

The baseline survey reported on in this paper was led by IRC Ethiopia on behalf of the Millennium Water Alliance Ethiopia Programme (MWA-EP), with surveys locally facilitated by NGOs Care, CRS, MCS, Water Action, and World Vision. Aqua for All and water.org who support the pilot in business development and financing issues also provided supporting inputs. Self-supply Acceleration pilot

## ACCELERATING SELF SUPPLY

### Progress in accelerating Self-supply

activities within the MWA-EP are funded by the Conrad N. Hilton Foundation and the activity partners. The baseline data collection was undertaken largely by woreda government officials.

#### References

- Butterworth, J., Sutton, S., Mekonta, L. (2013) Self-supply as a complementary water services delivery model in Ethiopia. *Water Alternatives*, 6(3): 405-423
- FDRE (2011). *The national WASH implementation framework*. Addis Ababa: FDRE. [online] Available at [www.cmpethiopia.org/media/full\\_wash\\_implementation\\_framework\\_wif/\(language\)/eng-GB](http://www.cmpethiopia.org/media/full_wash_implementation_framework_wif/(language)/eng-GB) (accessed 5 May 2016).
- Sutton, S., Butterworth, J. & Mekonta, L. (2012) *A hidden resource: household-led rural water supply in Ethiopia*. IRC International Water and Sanitation Centre, The Hague. [online] Available at <http://www.ircwash.org/resources/hidden-resource-household-led-rural-water-supply-ethiopia> (accessed 5 May 2016).

## ACCELERATING SELF SUPPLY

### Financing & scaling-up affordable rural water technologies

#### 3.4.2 Financing & scaling-up affordable rural water technologies

---

## Les technologies eau à faible coût dans le nord du Mali: des leçons apprises dans un contexte complexe (2006-2015)

---

Type: Article long

**Auteurs :** Abdoul Hamid Abdou, consultant independent WASH, Mali, [alhanafi52@gmail.com](mailto:alhanafi52@gmail.com), telephone: (00223)76213381; Michael F. MacCarthy, Mercer University

### Abstract/Résumé

Les technologies de Pompe à Corde et de la forage à la tarière manuelle pour l'approvisionnement en eau potable ont été introduites dans la région de Gao au nord du Mali en 2006, dans un contexte complexe qui comprend un climat désertique du Sahel et des crises humanitaires fréquentes. Ces technologies ont été effectivement transférées entre les années 2006 et 2009. Le soutien à long-terme suite à l'introduction de ces technologies a ensuite été considérablement entravé par la dégradation des conditions humanitaires dans la région. Cette étude décrit en premier lieu le contexte local dans lequel les technologies de l'eau à faible coût ont été introduites, et évalue l'état actuel des Pompes à Corde installées sur des forages manuels dans les zones d'intervention primaires par le biais d'une méthode mixte (constituée d'une enquête sur le terrain avec des entretiens semi-structurés et inspections techniques). Les résultats de l'étude montrent que plus de soixante pour cent des Pompes à Corde sont encore fonctionnelles après plus de 6 ans, en dépit du fait qu'un nombre important d'entre elles aient été abandonnées pendant un certain temps en situation de crise. La discussion est focalisée sur la façon de soutenir davantage la technologie de la Pompe à Corde et le marché du forage manuel à Gao, et les leçons apprises.

### Introduction

L'introduction des technologies de Pompes à Corde et la forage à la tarière manuelle pour les sources d'eau potable en milieu rural au nord du Mali remonte à 2006, avec le soutien principal du projet jusqu'en 2009. Le transfert de ces technologies dans la Région de Gao a été soutenu par des projets initiés par Oxfam Grande Bretagne (Oxfam GB) dans le cadre d'une réponse à la demande croissante en eau de boisson des populations en zone rurale, notamment dans les communes de Bamba et Téméra (cercle de Bourem dans la région de Gao au Mali). En 2015, on dénombre 90 pompes à corde installées avec des fabricants formés par Oxfam GB.

Suite aux conflits armés dans les régions nord du Mali depuis 2012, la mise en œuvre de ce plan a été stoppée dû au déplacements de population, ainsi que la fuite des services techniques et des ouvriers qualifiés. A cause de cette situation chaotique au nord du Mali, les infrastructures hydrauliques ont été dégradées ou vandalisées, et le service public de l'eau a été perturbé, ce qui a entraîné la baisse du taux de couverture en eau potable.

La conduite de cette étude permet de faire l'état de fonctionnalité des Pompes à Corde et de diagnostiquer les problèmes auxquels elles sont confrontés, tant sur le plan technique que social. Les résultats présentés sont issus de l'enquête sur l'état de fonctionnalité des Pompes à Corde installées sur des forages manuels dans les communes de Bamba et de Temera. Cette enquête s'est déroulée pendant une semaine en septembre 2015. La présente enquête fournit un aperçu général sur l'état de fonctionnement des pompes à corde au nord du Mali et les difficultés auxquelles les communautés sont confrontées.

## ACCELERATING SELF SUPPLY

### Financing & scaling-up affordable rural water technologies

#### Contexte, objectifs et activités

##### Objectifs de l'étude

L'objectif général de cette étude est d'évaluer l'état actuel de fonctionnement des Pompes à Corde et des forages manuels dans les communes de Bamba et Temera, cercle de Bourem dans la région de Gao au Mali.

Il y avait trois objectifs spécifiques pour cette étude, qui sont:

- (1) Etablir un état des lieux des Pompes à Corde et forages manuels installés,
- (2) Identifier les facteurs de risques d'utilisation de ce type d'équipement et en tirer les leçons, et
- (3) Formuler des recommandations pour une amélioration du fonctionnement de ces pompes.

L'exercice était fait de façon à suivre par étape la méthodologie de collecte des données constituée d'entrevues semi-structurées et d'inspections techniques. Si le questionnaire a permis de cadrer l'étude, l'impossibilité d'accéder à certains sites à cause de l'insécurité a posé problème. La critique générale qu'on peut formuler à ce niveau est que le contexte sécuritaire n'a pas permis de mener l'enquête sur les 34 ouvrages identifiés, mais sur 26 ouvrages dans les communes de Bamba et Temera. Cela reste néanmoins une méthodologie satisfaisante.

##### Sources d'eau souterraines au Mali

L'approvisionnement en eau potable des populations rurales et semi-urbaines utilise exclusivement les eaux souterraines qui sont, en général, de bonne qualité et disponibles presque partout au Mali mais en quantités très variables selon les conditions locales. Ces ressources sont renouvelables lors des saisons pluvieuses ou représentent des réserves fossiles. Les aquifères semi profonds sont essentiellement exploités par les forages et par un faible pourcentage de puits modernes. Des aquifères superficiels sont localisés dans les formations d'altération et les dépôts alluviaux et sont en liaison hydraulique avec les aquifères du substratum. Les eaux souterraines sont exploitées pour l'alimentation en eau par les puisards, les puits traditionnels, les puits modernes, les puits citernes et les forages.

##### Moyens d'exhaure conventionnels

L'utilisation généralisée des différentes technologies est soumise à un agrément délivré par les services de l'administration. En effet, la Stratégie Nationale de Développement de l'Alimentation en Eau Potable au Mali (SNDAEP) stipule : « Afin de mieux faciliter la maintenance, l'administration de l'eau fixera des modèles et types d'équipement admis par région et zone ». Ce choix technologique est normalement guidé par différents critères dont l'efficacité, la durabilité, le rapport qualité / prix et la garantie d'un service après vente. La Direction Nationale de l'Hydraulique (DNH) a donc retenu (par l'arrêté du Conseil des Ministres du 28 novembre 2007) certains types de pompes à motricité humaine par région, dont les marques India Mark II et Duba pour la région de Gao. Pour les forages profonds (dépassant 50 mètres), c'est la pompe Duba qui est utilisée, alors que la pompe India Mark II est utilisée pour les forages de moindre profondeur. La pompe India Mark II est importée directement de l'Inde, ce qui explique son prix élevé. En même temps, le taux de fonctionnalité de cette pompe est seulement de 56% dans la région de Gao selon un rapport d'évaluation du cluster WASH au Mali en 2012 (Cluster WASH au Mali, 2012). Cela en raison de la complexité de la pompe qui nécessite une réparation par des réparateurs plus spécialisés et basés au niveau de la ville de Gao, et non dans les villages, et aussi à cause d'un problème de disponibilité des pièces de rechange qui doivent être achetées à Bamako.

Par conséquent, les technologies disponibles et adoptées par l'Etat malien en matière d'eau ne sont pas toujours très appropriées dans un tel contexte de pauvreté et de sous-développement. Etant donné la cherté de ces ouvrages, l'investissement dans les agglomérations de moyenne et grande taille est généralement privilégié pour rentabiliser les coûts. De nombreux petits villages maliens (de moins de 400 habitants) en zone rurale se retrouvent donc sans point d'eau potable.

##### La Pompe à Corde au Mali

## ACCELERATING SELF SUPPLY

### Financing & scaling-up affordable rural water technologies

La Pompe à Corde est un type de pompe à eau efficace, simple à fabriquer et à entretenir, même localement, peu onéreux et utilisable de diverses façons, manuellement ou avec différentes sources d'énergie (traction animale, thermique, solaire). Il permet de pomper l'eau de 7m à 35m, voire 60 m pour certains modèles.

La Pompe à Corde est considérée comme une technologie à faible coût qui utilise des moyens appropriés et adaptés aux réalités locales et ayant un impact rapide sur le terrain. Elle est fabriquée localement par un nombre réduit d'opérateurs ou d'ateliers privés et peut être réparée localement au niveau du village où les compétences et pièces détachées peuvent être trouvées. Le nombre d'utilisateurs varie de 50 à 250 qui ne sont pas pris en compte dans la politique nationale de l'eau, qui indique comme norme 400 personnes par point d'eau moderne (DNH, 2007).

À la mi-2006, dans le cadre d'un projet visant à améliorer l'eau, l'assainissement et les conditions d'hygiène dans de nombreuses écoles primaires dans la région de Gao, Oxfam GB a eu l'occasion de tester des pompes à corde et les techniques de forage à la tarière manuelle, se fondant sur l'expérience récente de membre de l'équipe avec ces technologies en Afrique du Sud (Still et al., 2004; MacCarthy, 2004). Pour apprendre des succès précédents avec ces technologies dans le pays voisin du Niger (Naugle, 1996; Danert, 2006), l'équipe du projet a pris contact avec les principaux acteurs impliqués dans des travaux similaires, lors du 5e Forum RWSN à Accra, au Ghana en Novembre 2006. (RWSN, 2006).

En tant que «preuve de concept», pour aider à convaincre les différents acteurs de la faisabilité des techniques de forage manuel et des Pompes à Corde dans certaines zones de Gao, un kit de forage à la tarière manuelle et deux Pompes à Corde ont été préalablement importés du Niger. Un forage foré à la main a été réalisé dans une école primaire dans la ville de Ménaka (Cercle de Menaka), et équipé d'une Pompe à Corde. La deuxième Pompe à Corde importée a été installée sur un puits à grand diamètre existant dans une école primaire dans le village de Tabangout (Commune de Tessit, cercle d'Ansongo). Le forage foré manuellement a réussi, et les deux pompes ont été installées pour être appréciées des utilisateurs.

Après cette période de test, l'initiative de promotion de la Pompe à Corde comme moyen d'exhaure au nord du Mali a été prise par Oxfam GB en 2007 dans la région de Gao, afin de contribuer à l'amélioration de l'accès à l'eau potable, suite à la demande croissante en eau potable des populations en zone rurale. Avec l'appui d'Oxfam GB et la collaboration avec EnterpriseWorks/VITA, deux (02) ateliers de fabrication de Pompe à Corde du secteur privé ont été organisés à travers des projets pilotes dans les communes de Bamba et Téméra. Ainsi, deux entreprises ont été formées dans les techniques de la forage à la tarière manuelle.

En plus de l'introduction de la Pompe à Corde dans le nord du Mali, Oxfam GB a ensuite poursuivi les activités avec le développement du marché de la Pompe à Corde au niveau national. Dans le cadre de la promotion et le plaidoyer de la Pompe à Corde au Mali, la société civile en charge des questions de l'accès à l'eau potable au Mali (CN – CIEPA) a été engagée par Oxfam pour faire un plaidoyer en vue de l'homologation de la Pompe à Corde dans la stratégie nationale de l'approvisionnement en eau potable au Mali. Cette organisation s'est appuyée sur l'atelier Djékafo qui a déjà une expérience dans les technologies d'eau à faible coût depuis 2009 grâce à un appui technique et financier de WINROCK International. Cet atelier a reçu en février 2012 un renforcement de capacités sur la fabrication des pompes grâce à un appui technique et financier d'Oxfam dans le cadre d'un projet « Eau, hygiène et assainissement dans les écoles » financé par la fondation Dubai Cares. Il a ensuite été doté en matériel de fabrication des Pompes à Corde qui a vu la capacité technique améliorée. De 2011 à mars 2012, l'atelier Djékafo a installé une trentaine de pompes à corde dont 13 pour Oxfam. Il est en train de gagner sa vie dans les technologies à faible coût (forages manuels et Pompes à Corde) et est devenu une référence dans la promotion des technologies à faible coût au Mali.

## ACCELERATING SELF SUPPLY

### Financing & scaling-up affordable rural water technologies

A la fin du projet ECHO en 2009, l'entreprise LABATY a interrompu la fabrication des Pompes à Corde malgré l'accompagnement et l'encouragement d'Oxfam. Vu qu'il n'avait plus d'intérêt pour la Pompe à Corde, finalement il a transporté son atelier vers la frontière d'Algérie pour évoluer vers d'autres secteurs plus lucratifs.

La Pompe à Corde est utilisée au Mali pour une profondeur comprise entre 15 et 20m avec un niveau statique (NS) moyen de 5 à 10m. La Pompe à Corde présente un potentiel important pour une utilisation avec un niveau statique ne dépassant pas 15 m de profondeur.

Non seulement la Pompe à Corde a l'avantage d'être fabriquée entièrement localement créant ainsi des emplois dans le secteur privé, mais elle répond aux besoins des populations de part son utilisation simple, son faible coût de maintenance et l'enthousiasme qu'elle suscite. Le besoin des communautés rurales n'est plus à démontrer. Plusieurs communautés ne disposant pas encore d'un point d'eau moderne conventionnel souhaitent pouvoir bénéficier de cette technologie vue chez leurs voisins.

Depuis 6 ans l'atelier de fabrication Djekafo de Kati constate un nombre croissant de commandes venant de particuliers (souvent des notables) qui payent pour cette technologie sur fonds propres.

#### Zone d'intervention

La zone d'intervention du projet dans les communes de Bamba et Temera (Région de Gao) est composée de villages le long du fleuve Niger. Cette zone avait le taux de malnutrition le plus élevé de la région de Gao, avec la conviction que cela était dû en partie au fait qu'une grande partie de la population prennent leur eau de boisson directement du fleuve Niger. A l'époque, le choléra était endémique dans la zone d'intervention. Considérant l'hydrogéologie de la zone, on a déterminé que la zone d'intervention était appropriée aux forages manuels, avec un aquifère peu profond près des rives du fleuve Niger, et une formation de sables alluviaux.

#### **Résultats principaux et leçons tirées**

##### Méthodologie

L'enquête a été réalisée sur 26 pompes à corde installées sur des forages manuels. On a procédé d'abord à l'identification des responsables des pompes et des membres des comités de gestion des points d'eau concernés. Cette démarche a permis de recueillir le feedback de ces usagers sur l'ouvrage avant même d'aller diagnostiquer la pompe sur le terrain.

Concernant les entrevues, elles se sont déroulées dans les différentes localités concernées par l'enquête et auprès des personnes qui utilisent actuellement la Pompe à Corde. Ces entrevues ont été suivies par une visite de l'ouvrage pour constater et peaufiner les informations fournies par les personnes rencontrées dans chacun de ces localités.

##### Résultats principaux

Les résultats principaux sont divisés en partie selon: (1) l'état de fonctionnement des pompes, (2) la durée de vie des pompes, (3) la nature des pannes, (4) la fréquence des pannes, et (5) la perception des usagers sur la Pompe à Corde.

##### *Etat de fonctionnement des Pompes à Corde et forages manuel*

Selon le constat effectué, 62% des pompes à corde visitées fonctionnent contre 38% qui sont en état d'arrêt (*Figure 1*). La maintenance et l'entretien des pompes sont faibles en comparaison avec d'autres pompes manuelles à faible coût et en raison de la simplicité de la conception. A titre de rappel, selon une évaluation de 2012 du cluster WASH du Mali, c'est seulement 56% des pompes India Mark II qui fonctionnent dans le Nord du Mali (Cluster WASH au Mali, 2012). La maintenance et l'entretien des pompes à corde sont directement faites par les responsables des pompes eux-mêmes, avec les quelques pannes et pièces détachées disponibles localement dans le secteur privé local selon le constat effectué.

## ACCELERATING SELF SUPPLY

### Financing & scaling-up affordable rural water technologies

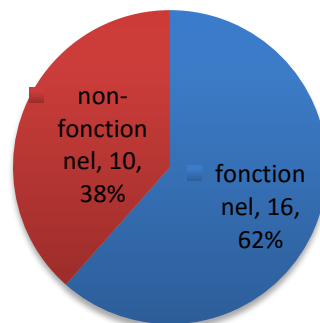

Figure 1: Etat de fonctionnalité des Pompes à Corde

Tous les forages ont des niveaux d'eau adéquats. Il n'a été constaté aucune corrélation entre la profondeur initiale des forages manuels et les profondeurs actuelles de ces mêmes forages. On pensait avant le début de l'étude que ces deux variables pourraient avoir une incidence sur la cote d'installation des pompes à corde. Vu que l'écart entre la cote d'installation de la pompe et le fond du forage n'atteint pas 1 metre, cette situation pourrait augmenter la pression sur les cordes et les rondelles. Aussi elle pourrait causer un endommagement de la colonne fontante à cause du fond qui pourrait être rempli de sable.

Ainsi, cela ne s'est pas avéré être le cas: la mauvaise manipulation de la pompe et le manque des pièces de rechange pourraient être responsable de l'usure des pièces de la pompe, bien que cela n'a pas été étudié.

Selon le constat effectué, l'argent de la caisse mobilisée par les comités de gestion des points d'eau à travers les cotisations des communautés a été utilisé pour payer les frais de réparation, de maintenance et d'entretien des pompes. Les dépenses effectuées par communauté varient d'un village à l'autre et elles sont comprises entre 5000 FCFA et 50,000 FCFA depuis leur installation. Cette différence est fonction de la taille du village et de la durée de vie de la pompe. A titre d'exemple, le village de Kalansar a dépensé 50,000 FCFA pour réparer les pannes de leur pompe; c'est un village qui comptabilise 600 personnes et la Pompe à Corde est installée depuis 2007. *Figure 2* montre deux Pompes à Corde de l'enquete.



## ACCELERATING SELF SUPPLY

Financing & scaling-up affordable rural water technologies

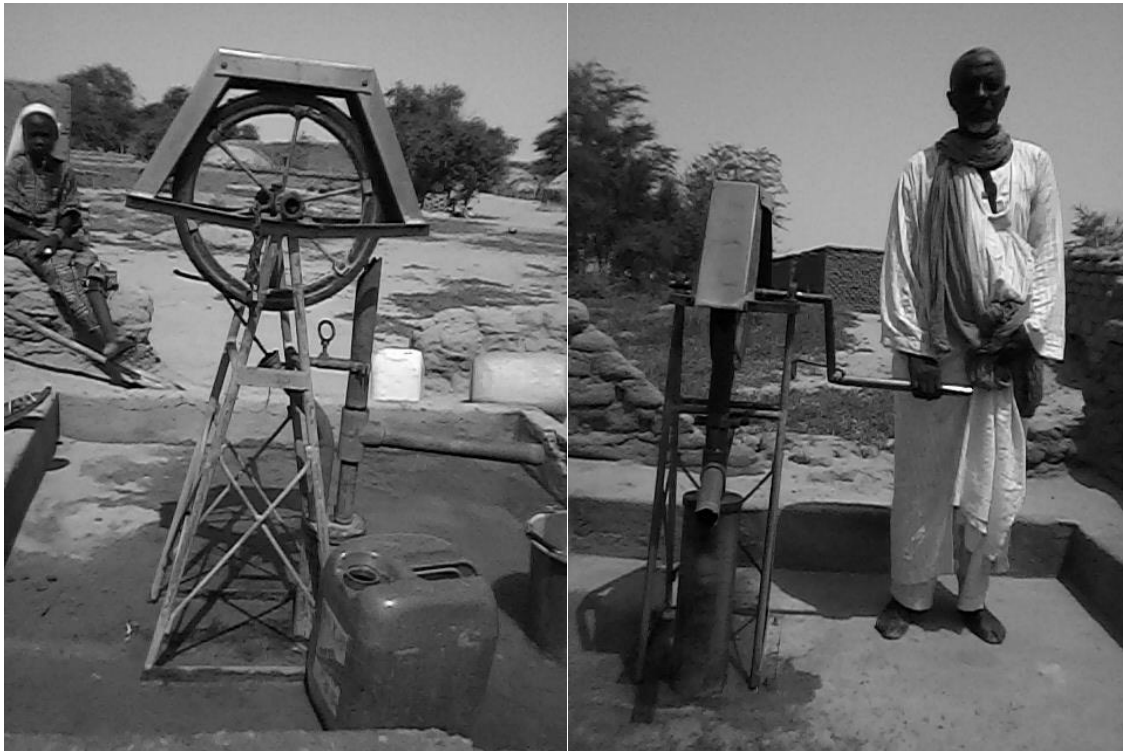

Figure 2: (a) Point d'eau à Temera, forage à faible coût équipé avec une Pompe à Corde (gauche); (b) Point d'eau à Temera, forage à faible coût équipé avec une Pompe à Corde installée en déc. 2007 (droite)

### *Durée de vie des Pompes à Corde*

Selon le constat effectué, 35% des pompes visitées ont une durée de vie de plus de 6 ans et 65% ont une durée de vie de 6 ans (Figure 3). On pensait avant le début de l'enquête que la durée de vie des pompes pourrait avoir une incidence sur l'usure des pièces de rechange et l'arrêt des Pompes à Corde. Cela ne s'est pas avéré être le cas puisque sur 10 pompes installées entre 2007 et 2008, 7 pompes fonctionnent normalement, soit un taux de fonctionnement de 70% malgré le fait que les structures de ces pompes aient besoin de renouvellement. Ces pompes ont environ une durée de vie d'environ 8 ans, ce qui témoigne de leur durabilité et de leur performance comparativement à la durée de vie d'une pompe manuelle conventionnelle au Mali qui a une durée de vie de 7 ans, selon une évaluation socioéconomique des pompes manuelles sur la GIRE menée au Mali en 2005 (DNH, 2005).

### *Nature des pannes*

Selon le constat effectué, les raisons principales des pannes sont à 30% l'usure des cordes et à 22% - une cassure de roulement. Selon les informations recueillies auprès de certains responsables des pompes, 28% des pannes résultent à la fois de l'usure de la corde et de la cassure des roulements. 76% des pompes en panne sont non fonctionnelles depuis plus de 3 mois alors que 12% des pompes en panne sont non fonctionnelles depuis plus de 2 ans, ce qui laisse à penser qu'elles sont rapidement abandonnées par défaut de suivi de l'entretien et la maintenance des points d'eau. Nous avons constaté aussi que certains villages dont les pompes sont non fonctionnelles ont bénéficié de puits à grand diamètre par des projets d'eau et d'assainissement de l'Etat ou d'autres intervenants; d'autres vivant à proximité (moins de 100 m) consomment directement l'eau du fleuve malgré le programme de promotion de l'hygiène qui a accompagné l'installation des pompes à corde par Oxfam GB.

Figure 3 explique les causes de non réparation des Pompes à Corde. Selon le constat effectué, les raisons de non – réparation sont à 59% financières, 20% dû au manque de compétences, 14% mécaniques et 7% d'insuffisances d'eau dans le forage manuel surtout en période de saison sèche.

## ACCELERATING SELF SUPPLY

Financing & scaling-up affordable rural water technologies

### Causes de non-reparation des Pompes a Corde

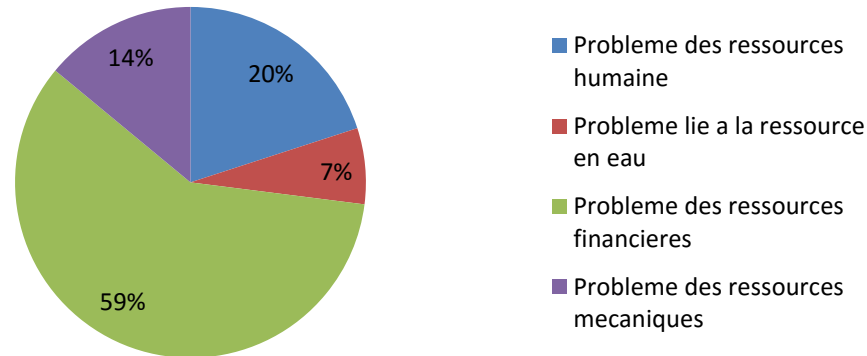

Figure 3: Causes de non-reparation des Pompes a Corde

Selon les informations recueillies auprès de certains responsables de pompes, la plupart des pompes non fonctionnelles ont été abandonnées à cause de l'occupation des régions du Nord par les groupes islamistes armés de 2012, ce qui a entraîné le déplacement des populations dans d'autres zones plus sécurisées. L'occupation des régions nord du Mali par les groupes armés a entraîné le déplacement de près d'un demi-million de personnes sur le territoire malien mais aussi vers les pays limitrophes. C'est à la suite de l'intervention française « SERVVAL » au Mali en janvier 2013 que les populations sont retournées dans leurs villages/localités trouvant leurs biens pillés et vandalisés y compris les points d'eau. Certaines communautés ont repris leurs activités y compris la gestion des points d'eau mais d'autres peinent à se relever. Selon la Matrice de Suivi des Déplacements de l'Organisation Internationale pour la Migration (OIM) dont l'objectif majeur est de fournir des données actualisées sur les populations déplacées ainsi que sur l'ensemble des personnes affectées par le conflit (communautés hôtes, personnes retournées), 334 550 déplacées sont dénombrés en juillet 2013 et 283 726 en octobre 2013, ce qui démontrerait le retour progressif des déplacés dans leurs zones d'origine. 105,533 personnes (dont 57% d'enfants soit 60,603) ont été comptabilisées de retour dans la région de Gao depuis mai 2013 (OIM, 2014).

Au retour de ces populations, il n'y a pas eu d'appui financier et technique pour mettre en état de marche ces pompes qui sont restés finalement dans cette situation. *Figure 4* montre trois Pompes a Corde différentes en état de non-fonctionnement.

## ACCELERATING SELF SUPPLY

Financing & scaling-up affordable rural water technologies



Figure 4: (a) Point d'eau à Temera, Forage manuel dont la Pompe à Corde est emporté et vandalisée (gauche); (b) Point d'eau à Temera, Pompe à Corde dont la corde et les roulements sont cassée (milieu), Point d'eau à Bamba, Pompe à Corde vandalisée (gauche)

### *Fréquence des pannes*

Selon le constat effectué, les pannes les plus fréquentes sont principalement dues à l'usure de la corde (41%), la cassure des roulements (26%) et la cassure des tuyaux (23%) (Figure 5). Les réparateurs villageois arrivent à réparer la pompe en cas de panne. Les principales pièces d'usure (la corde et le roulement) sont disponibles localement et coûtent respectivement 200 FCFA le mètre pour la corde et 750 FCFA pour le roulement. A la fin du projet financé par ECHO en 2009, Oxfam avait identifié dans chaque commune (Communes de Bamba et Temera) un commerçant fournisseur de pièces de rechange de Pompes à Corde. Ces fournisseurs ont reçu une dotation en pièces de rechange grâce à l'appui financier du projet pour développer le marché. Cette activité a été accompagnée de séances d'information auprès des communautés sur la présence de ces fournisseurs de pièces de rechange dans les chefs-lieu de communes.

## ACCELERATING SELF SUPPLY

### Financing & scaling-up affordable rural water technologies

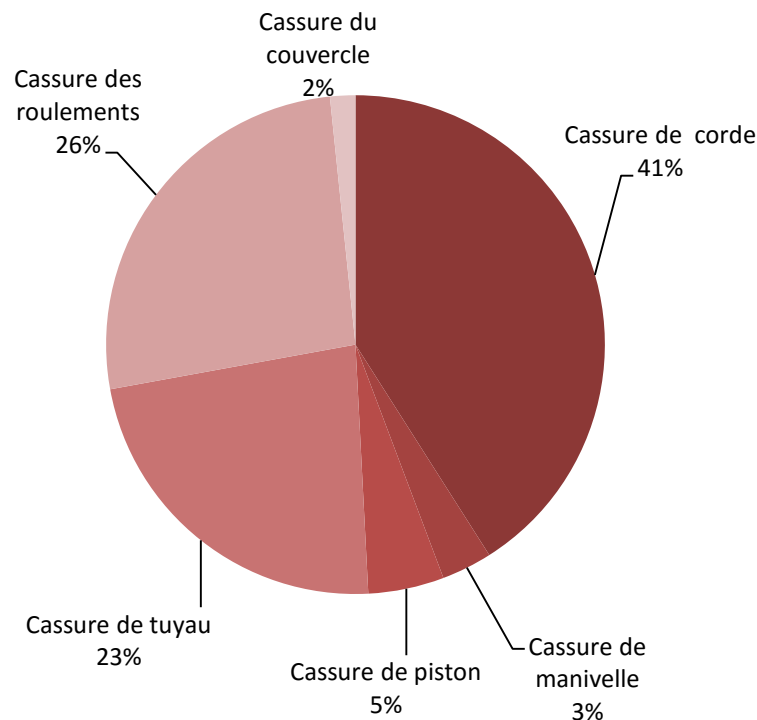

Figure 5: Causes des pannes des Pompes à Corde

#### Perception des usagers sur la Pompe à Corde

La plupart des personnes interrogées ont affirmé qu'elles étaient satisfaites de la Pompe à Corde compte tenu qu'elle est facile à entretenir par les usagers eux-mêmes à un faible coût, comparé à la pompe India Mark II dont les pièces de rechanges ne sont pas disponibles localement et dont les réparations sont difficiles à effectuer dû au manque des ressources humaines locales. Selon un responsable de Pompe à Corde du village Bamba Ile « notre pompe donne une bonne eau, quand elle tombe en panne, nous appelons le réparateur qui vient réparer le jour même et les pièces de rechange sont disponibles localement. Je me souviens en 2012 pendant l'occupation du Nord Mali par les groupes armés, il y a eu une crise de choléra mais toute la commune de Bamba y a échappé miraculeusement en partie grâce à ces forages manuels équipés de Pompes à Corde que la population a bien compris étaient dans leur intérêts »

Lors du passage à Bamba pour l'enquête, il a été constaté que certains individus ont déjà installé leur propre Pompe à Corde au sein de leur concession. Dans le cadre de l'installation des artisans foreurs au niveau local, Oxfam GB a recruté 2 équipes de forages manuels dont 1 à Temera et 1 à Bamba. Ces équipes de forages ont été formés par un spécialiste des forages manuels venant du Niger (contracté par EnterpriseWorks/Vita) sur la technique de forage à la tarière. L'équipe de Temera n'a pas survécu à la fin du projet mais celle de Bamba a continué avec les forages manuels dans la commune de Bamba. C'est ainsi qu'à la demande des particuliers, elle a réalisé une vingtaine des forages manuels soit dans des jardins maraichers, soit pour des particuliers qui ont été équipés de Pompes à Corde.

#### Conclusions et Recommandations

Aujourd'hui, on dénombre environ 90 pompes à corde installées dans les communes de Bamba et Temera grâce à l'appui des projets initiés par Oxfam GB qui remonte à 2007 avec un taux de fonctionnalité de 62 % sur 26 pompes concernées par cette enquête. Comparativement aux pompes conventionnelles (India Mark II, Duba et Vergnet), le taux de fonctionnalité est appréciable. En ce qui concerne les forages forés manuellement, 100% des forages visités avaient de l'eau, et les usagers ont indiqué que tous les forages avec des pompes fonctionnelles avaient de l'eau en quantité suffisante.

## ACCELERATING SELF SUPPLY

### Financing & scaling-up affordable rural water technologies

L'attrait de la Pompe à Corde est dû à son faible coût d'acquisition par rapport aux pompes conventionnelles (India Mark II, Duba et Vergnet) et à la possibilité de réparation simpliste sans nécessité de pièces de rechanges manufacturées. Cependant 38% de ces pompes, installées depuis environ 7 ans, sont en panne en raison de l'usure des certaines pièces (cordes, roulements, tuyaux, etc.), ou dû à une mauvaise application ou à l'absence de mesures d'appropriation des populations garantes de la pérennité du point d'eau. Des efforts devront pourtant continuer afin de consolider les acquis (le taux de fonctionnalité est de 62%) et de mettre en application les recommandations de l'enquête.

Bien que les bénéfices sur leur état de santé ne peuvent pas être attribués à l'utilisation de ces points d'eau directement, les utilisateurs le perçoivent comme tel, comme en témoigne le responsable de la pompe à Bamba Ile. La Pompe à Corde peut être facilement entretenue et réparée par les utilisateurs, les pièces de rechange sont disponibles localement et sont produites dans la région. Tous les répondants ont trouvé que la Pompe à Corde est plus facile à utiliser que leur ancienne méthode de collecte de l'eau.

L'enquête sur les pompes en panne a montré qu'une pluralité de facteurs impacte la fonctionnalité des ouvrages, dont certains facteurs externes à la gestion, tel que l'occupation des régions Nord du Mali qui a entraîné le déplacement des populations dans certaines localités. La bonne gestion et l'entretien de l'ouvrage restent quand même parmi les facteurs clé, ainsi que l'usure de la corde et l'entretien préventif qui n'est pas effectué dans beaucoup de cas, associé à une mauvaise gestion financière. La majorité des personnes rencontrées évoquent le manque de ressource comme principale cause de non-reparation d'où l'importance d'encourager les efforts du fabricant des pompes à corde de Kati (à côté de Bamako) dans ces initiatives de renforcer la qualité de la Pompe à Corde.

De ce qui précède il est formulé les principales recommandations suivantes :

- Améliorer la fabrication et le choix des matériaux à travers une version plus robuste (comme le modèle en cours de fabrication par le fabricant de Kati au Mali),
- Recycler et former un nombre suffisant d'ateliers aux techniques de fabrication de la Pompe à Corde avec la prise en compte des modifications apportées par le fabricant de Kati,
- Améliorer la disponibilité des pièces de rechange,
- Accompagner et recycler les bénéficiaires sur les opérations de maintenance réalisables à leur niveau (ex : démontage pompe et changement de la corde),

Les résultats de l'étude montrent que, malgré une période extrême d'insécurité dans la région, qui a duré plusieurs années et est toujours en cours, la majorité des Pompes à Corde examinées étaient encore fonctionnelles. Les recommandations ci-dessus peuvent être mises en œuvre par les acteurs locaux pour aider à augmenter les taux de fonctionnalité des systèmes de Pompes à Corde existants, et aider à renforcer le marché pour les systèmes d'eau à faible coût durable dans le nord du Mali. Les enseignements tirés de cette étude ne sont pas seulement précieux pour l'amélioration de l'existant, mais aussi à l'introduction et l'amélioration des technologies à faible coût dans des contextes de développement humanitaire similaires complexes.

### Mentions

Les auteurs remercient Oxfam GB et ECHO pour financer les activités de mise en œuvre (2006-2009), ainsi que Ibrahim Mamadou et Jonathan Naugle (anciennement de EnterpriseWorks / Vita) et Dr Kerstin Danert (RWSN) pour leur soutien. Mohamed Idrissa Touré et Ibrahim Mahamadou sont remerciés pour la collecte des données de l'enquête, et les habitants de Bamba et Temera communes sont remerciés pour leur collaboration.

### Références

- Cluster WASH au Mali (2012). *Rapport d'évaluation, cluster WASH Mali*.
- Danert, K. (2006). *A brief history of hand-drilled wells in Niger*. *Waterlines*, 25(1), pp.4-6.
- DNH (2005). *Module 5 des études thématiques de la GIRE : Aspects économiques et financiers des ressources en eau*, juillet 2005 (par SOFRECO au compte de la DNH).

## ACCELERATING SELF SUPPLY

### Financing & scaling-up affordable rural water technologies

- DNH (2007). *Stratégie nationale d'approvisionnement en eau potable au Mali*. Direction National de l'Hydraulique.
- MacCarthy, M.F. (2004). *The Development of the Rope and Washer Pump for use with Tubewells in Maputaland, South Africa*. University of Southampton.
- Naugle, J. (1996). *Hand Augered Garden Wells*. 3<sup>rd</sup> Edition. Lutheran World Relief.
- OIM (2014). *Matrice de suivi des déplacements - Mali (Displacement Tracking Matrix DTM), 2013*. Organisation Internationale pour la Migration, February 2014.
- RWSN (2006). *Proceedings of the 5th RWSN Forum 2006 Ghana. Scaling up Local Entrepreneurship in Rural Water Supply to meet the MDGs*, Skat Foundation, MWRWH, RWSN, St Gallen, Switzerland
- Still, D.A., Nash, S.R. and MacCarthy, M.F. (2004). South African experience with hand-augered shallow wells in coastal aquifers. In *IWA/WAMDEC Conference, Victoria Falls, Zimbabwe* (pp. 28-30).

## ACCELERATING SELF SUPPLY

Financing & scaling-up affordable rural water technologies

# Low-Cost Household Groundwater Supply Systems: Pitcher Pump Systems and EMAS Technologies

Type: Long Paper

**Authors** Michael F. MacCarthy, Assistant Professor, Mercer University, USA, [maccarthy\\_m@mercer.edu](mailto:maccarthy_m@mercer.edu), tel: +1 478 301 5480; Jacob D. Carpenter, Independent WASH Consultant; Jonathan E. Annis, Tetra Tech ; James W. Buckingham, Independent Engineer; James R. Mihelcic, University of South Florida

### Abstract/Summary

Self-supply is common throughout the world, filling service gaps left by other forms of water supply provision. This research assesses low-cost household groundwater supply technologies in developing country contexts in sub-Saharan Africa and Latin America, with a focus on the potential for improving Self-supply technology implementation in sub-Saharan Africa. Specifically, a Self-supply market for Pitcher Pump systems is studied in eastern Madagascar, EMAS low-cost water supply technologies are assessed in Bolivia, and a technical comparison is completed with the EMAS Pump and a family version of the Rope Pump in Uganda. Primarily technical and financial elements of sustainability are assessed. In Madagascar, the Pitcher Pump system market is found to be mature, unsubsidized, and sustainable, while there are some issues with the delivered water quality. In Bolivia, EMAS manually drilled well and pump systems are found to have a high rate of functionality. The pump comparison study concluded that, based on its relative low-cost, similar pumping rates to common versions of the Rope Pump from depths less than 20 m, and the minimal resources needed to construct it, the EMAS Pump has potential for success as a Self-supply technology in sub-Saharan Africa.

### Introduction

Private household and small-group water supplies offer the potential to complement community water supply systems, either in their place (when public systems are non-existent or not accessible), or as secondary sources for households to use alongside community systems. When used in combination with community systems, household systems can offer several advantages, including reducing demand on community systems that struggle to supply sufficient quantities of water to all users.

The past decade has seen an increased interest in household water supply as a means of improving access to drinking water in developing countries. ‘Self-supply’ is a term that is commonly used, and is defined as “the improvement to household or community water supply through user investment in water treatment, supply construction and upgrading, and rainwater harvesting” (Sutton, 2009).

Self-supply encourages users to make affordable, incremental improvements to their private family or neighborhood (i.e. small group) water supply systems. Where it is possible implementation of Self-supply can result in “the obstacles to sustainability created by a lack of trust, cohesion, and co-operation within communities” being greatly reduced (Harvey and Reed, 2007). Self-supply can be complementary to community water supply systems, and has great potential as part of wider national strategies to reach the Sustainable Development Goal (SDG) target for safe and affordable drinking water for all and contribute to other SDG objectives related to health and livelihoods.

Low-cost household water supply technologies often make use of either groundwater in the immediate vicinity around a household, or rainwater that falls in a similar area. Common low-cost household water supply technologies include: (1) family wells, which can be either hand-dug or manually drilled; (2) water-lifting devices, which can range from being as simple as a rope attached to a bucket, to a manually-operated pump; and (3) rainwater harvesting systems. Low-cost water supply technologies are increasingly being promoted as sustainable solutions when implementing water supply projects at the small-

## ACCELERATING SELF SUPPLY

### Financing & scaling-up affordable rural water technologies

community or household level in developing areas. Some low-cost technologies used in Self-supply are based on concepts that were originally developed in China over a thousand years ago (Missen, 2003; Sutton and Gomme, 2009).

#### **Context, aims and activities undertaken**

This research explores sustainable implementation of low-cost household groundwater supply systems in developing communities, with a focus on functional sustainability and primarily assessing technical and financial elements of sustainability. Different such technologies are investigated at two primary study locations (i.e., Bolivia and Madagascar) and one secondary study location (Uganda). Through these studies (each published separately), possibilities for improvements to household water supply technologies for developing communities are recommended, including further research, with an emphasis on the wider applicability of such technologies in sub-Saharan Africa.

*Case Study 1* assesses the sustainability of a low-cost groundwater supply system, the Pitcher Pump system, which has been produced and sold in Madagascar for more than five decades. The Pitcher Pump, which is manufactured independently by many small businesses in eastern Madagascar and sold to private users at unsubsidized market prices, provides an example of a mature Self-supply market in a sub-Saharan African context that has proven to be sustainable over many years. Mixed methods are used to assess the Pitcher Pump technology and market in eastern Madagascar, including Pitcher Pump system construction practices, pump performance, system management, water quality, and household drinking water treatment practices. The scope of ongoing research is also discussed, and recommendations for potential improvements are provided.

*Case Study 2* provides a brief overview of three types of low-cost household water supply technologies appropriate to Self-supply (manual water pumps, manual well drilling techniques, and rainwater harvesting systems), in the context in which specific models of these types of technologies have been developed by EMAS and implemented in Bolivia. Through assessing the technical capabilities and the context in which these technologies have proven to be effective, the research provides insight into the potential for introducing these technologies in other developing community contexts.

*Case Study 3* offers a technical comparison between the EMAS Pump and the family Rope Pump, which has been introduced in many developing countries in recent years and most successfully marketed as a household-level pump in Nicaragua (Sutton and Gomme, 2009). The study allows development practitioners and researchers to better understand the technical attributes and capabilities of the EMAS Pump compared with the family Rope Pump (as well as other documented low-cost pumping devices) as a Self-supply option for developing communities and emphasizes the potential for the EMAS Pump in sub-Saharan Africa.

The lessons learned from the three case studies help to form recommendations for improving and introducing the studied low-cost water supply technologies in new contexts, and for further research.

#### Research Questions

The overall goal of the research is to assess low-cost household groundwater supply options for their suitability to sustainable use in developing communities, particularly in sub-Saharan Africa, and evaluate possibilities for improving and/or introducing household water supply technologies to such contexts. The research aims to address the following research questions:

1. What improvements can be made to the Pitcher Pump system in Madagascar to improve the quality of the product (including reliability, pumping rates, and/or quality of extracted water)?
2. Are low-cost water supply systems developed in Bolivia (EMAS technologies) suitable, affordable options for household water supply (Self-supply) for developing communities in sub-Saharan Africa?



## ACCELERATING SELF SUPPLY

### Financing & scaling-up affordable rural water technologies

3. Would the EMAS Pump be an effective, less-costly alternative to the family Rope Pump, potentially offering new opportunities for households or small groups of families in sub-Saharan Africa to improve their private water supplies?

4. Based on the results of Research Questions 1 through 3, what recommendations can be offered to improve sustainable low-cost water supply systems for use at the household level in developing contexts in sub-Saharan Africa?

#### Main results and lessons learnt

##### Case Study 1: Pitcher Pump Systems in Madagascar

This study highlights research carried out by the University of South Florida and the USAID-funded RANO HP project managed by CRS and CARE (see Akers, 2014; Akers et al., 2015; Akers et al., 2016; MacCarthy et al., 2013a; MacCarthy, 2014; Wahlstrom-Ramler, 2014). Further information on this case study can be found in *Unsubsidised Self-Supply in Eastern Madagascar* (MacCarthy et al., 2013a).

##### Context

According to the most recent Joint Monitoring Program (JMP) update, improved drinking water coverage in Madagascar in 2015 was estimated to be 35% in rural areas and 82% in urban areas (JMP, 2015). The national parastatal water and electric company, JIRIMA, who manages piped schemes that supply water to 65 urban municipalities, suffers from operational inefficiencies and lacks the capacity to upgrade aging infrastructure (USAID, 2010). In rural areas of Madagascar, coverage remains very low, with various challenges to maintaining existing systems and expanding services to the majority who are unserved.

Traditional Self-supply practices in Madagascar include household wells and household rainwater harvesting systems (to a more limited extent). Hand-dug wells using rope-and-bucket water-lifting systems are common at the household level in many parts of the high plateau region of central Madagascar. In coastal areas with sandy soils and shallow water table depths, manually drilled wells and suction handpump systems are prevalent in family compounds in many communities. This type of low-cost system, the Pitcher Pump system (locally called “Pompe Tany”), shown in *Figure 1*, was reportedly first introduced in Madagascar over five decades ago.

As shown in *Figure 1(b)*, the Pitcher Pump has two check valves (one on the lower end of the pump head, and a second one on a piston that attaches to the pump handle via a rod) and the pump is installed directly on a drilled well. In Madagascar, the check valves are usually made of leather and weighted with lead (Pb). The well is installed by manually boring (coring) down to near the water table, then hammering into the ground a permanent galvanized iron casing pipe that includes a well screen and a pointed drill bit (well-point) at its lower end.

## ACCELERATING SELF SUPPLY

### Financing & scaling-up affordable rural water technologies

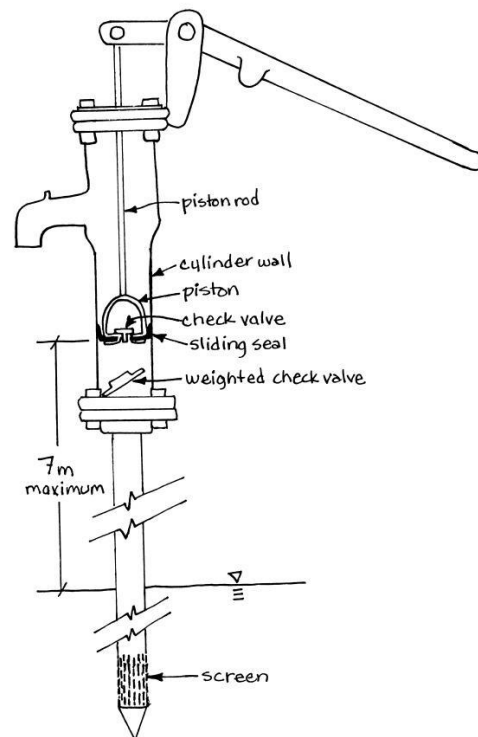

Figure 1: (a) Pitcher Pump in use in Tamatave, Madagascar [left] (Photo: M. MacCarthy); (b) Diagram of Pitcher Pump system [right] (Source: Artwork by Linda Phillips. Reproduced from Mihelcic et al. (2009); with permission from ASCE.)

### Methodology

Data related to Pitcher Pump systems were collected in the city of Tamatave (estimated population of 280,000) and the nearby town of Foulpointe (estimated population of 15,000) in the Antsinanana Region of eastern Madagascar. The field research made use of mixed methods, consisting primarily of a quantitative survey of households that owned Pitcher Pump systems, semi-structured interviews with pump manufacturers, inspection/observation of household water and sanitation infrastructure, and testing of water quality (faecal coliforms, lead, nitrate, etc.). Supplementary methods consisted of focus group interviews with owners of Pitcher Pump systems. Primary field data were gathered over a four-week period in August-September 2011, and a local research assistant gathered additional data in 2012 and early-2013.

### Main Results and Discussion

The primary findings of the research study include:

#### *1) Strong evidence of a robust, sustainable market for Pitcher Pump systems in Tamatave, Madagascar*

There are an estimated 9,000 Pitcher Pump systems in use throughout the city of Tamatave (and an estimated 12,000 total in Madagascar). 94% (50 of 53) of households surveyed reported that their Pitcher Pump system wells provide water throughout the entire year, with the other respondents saying that their wells provide water 10-11 months per year. It is estimated that more than 50 separate local small businesses in Tamatave (usually small welding workshops) manufacture Pitcher Pumps. This market is believed to be the most significant documented example of an unsubsidized household handpump market in sub-Saharan Africa.

#### *2) Pitcher Pump systems built locally at an affordable price*

Complete Pitcher Pump systems are commonly sold in Tamatave and Foulpointe at unsubsidized prices of \$35-100. This price includes system construction and installation, with the variance in cost largely dependent on well depth. The price of the Pitcher Pump itself is typically US\$15-25, with system

## ACCELERATING SELF SUPPLY

### Financing & scaling-up affordable rural water technologies

components and installation costing an additional US\$5-7 per metre of depth. All households surveyed reported paying the full purchase price of their Pitcher Pump system themselves, without subsidy.

#### *3) System maintenance and repair effectively managed by local technicians*

Pitcher Pump systems were shown to provide reliable and convenient access to water at a low cost relative to household connections to the piped water system. Owners commonly share maintenance and repair costs with their tenants and/or neighbors. System maintenance is done by local technicians or family members, with more significant repairs undertaken by local technicians or manufacturers.

#### *4) Concerns with drinking water quality*

There are, however, concerns with the quality of water supplied through these systems (i.e. its suitability for drinking and cooking), specifically microbiological and lead contamination. Only 55% of wells sampled provided water associated with low-risk of microbial contamination for household systems (i.e. 10 or less thermotolerant coliforms per 100 ml), and four out of a small sample of ten wells contained lead (Pb) in excess of guidelines set by the World Health Organization. Measured nitrite levels were below WHO guidelines, but suggest some impact on the groundwater supply by anthropogenic activities associated with waste disposal.

#### *5) Users commonly drink Pitcher Pump system water, with water heating/boiling being common*

75% of surveyed families reported drinking water from Pitcher Pump systems, with 15% of these families first chlorinating the water, and 58% boiling it prior to drinking (including two families reporting doing both). Considering the local practice of drinking heated rice water, it is unclear if proper boiling is being done to provide sufficient treatment against bacteriological contamination. In focus group discussions, a small number of Pitcher Pump system owners insisted that the water from their systems was potable (and of no risk to their health) without any treatment, while the great majority understood that the water from their systems was likely contaminated, yet said they commonly drink it without treating it. A minority of focus group participants reported the water from Pitcher Pump systems to be not of potable quality and reported either treating the water (through boiling) prior to drinking, or collecting drinking water from an alternative source.

### Further Research

Further research is needed to determine potential improvements to Pitcher Pump systems, to understand how to create synergies between the Pitcher Pump market and utility piped water system, as well as to determine the feasibility of household water treatment and rainwater harvesting Self-supply options to improve access to drinking water.

To this point, continued research led by the University of South Florida and Mercer University has focused on the following aspects:

#### *1) Technical Improvements to the Pitcher Pump system*

(a) The identification of lead (Pb) contamination in Pitcher Pump systems in this study has been followed up with a more in-depth study, which confirmed Pb contamination in Pitcher Pump systems to be a significant issue, and identified the major source of this contamination as the Pb valve weights used by most system manufacturers. Secondary sources are lead in commonly used brass well screens, as well as lead-tin solder used to attach the screen to the well pipe (Akers, 2014; Akers et al., 2015; Akers et al., 2016). Recommendations include replacement of leaded valves with iron valves, and, in the absence of valve replacement, flushing of the well prior to using water for drinking, cooking, or bathing.

(b) A second follow-up study investigated fecal contamination in Pitcher Pump systems in Tamatave, Madagascar (Wahlstrom-Ramler, 2014). This study did not find any link between Pitcher Pump system well depth and level of contamination (which was a suggested possibility from the Madagascar case study analysis). However, the fecal contamination study found that Pitcher Pump priming (needed when pump valves don't seal properly) was a significant factor in microbiological water quality in these systems, due to priming with apparently contaminated water.

## ACCELERATING SELF SUPPLY

### Financing & scaling-up affordable rural water technologies

(c) An ongoing manual drilling study for Madagascar is exploring: (i) ways of improving water quality through use of alternative well-lining materials and drilling methods that reduce/eliminate the use of Pb-containing components in the well screen drilling (Wohlrabe, 2015); and (ii) expanding the household groundwater supply market to areas with more diverse hydrogeological conditions (i.e. deeper water tables, harder soils) through the use of alternative manual well drilling and water pumping technologies.

(d) A current study in Tamatave is exploring options for low-cost well-head protection (i.e. sanitary aprons) for the Pitcher Pump system as a measure to improve bacteriological water quality.

#### *2) Formative Research in Social Marketing*

Ongoing research is identifying the factors that Pitcher Pump users and Pitcher Pump manufacturers find important about Pitcher Pump systems (i.e. why do consumers continue to buy, use them; why do manufacturers keep making, selling them).

#### *3) Development of the Self-Supply Market in Madagascar beyond Pitcher Pump systems*

Ongoing research is focusing on assessing other traditional Self-supply practices in areas of Madagascar (e.g. hand-dug wells in the south-central highlands, rainwater harvesting systems in the south of the country, etc.). Field data has been collected during four field “rapid assessments”, and will contribute to a future field note publication on the potential for accelerating Self-supply in Madagascar, aimed at disseminating the acquired knowledge to local stakeholders in Madagascar (and beyond).

## Case Study 2: EMAS Water Supply Technologies in Bolivia

This study highlights research carried out by the University of South Florida. Further information can be found in *Increasing Access to Low-Cost Water Supplies in Rural Areas: EMAS Household Water Supply Technologies in Bolivia* (MacCarthy et al., 2013b).

### Context

The most recent JMP estimate shows that, as of 2015, 76% of the rural population of Bolivia have access to improved drinking water sources. This rural water supply coverage statistic has increased significantly since 1990, when the percentage of rural users with improved drinking water sources was estimated at 40%. (JMP, 2015).

Bolivia has a significant recent history of developing low-cost water supply technologies, particularly of manual drilling and handpumps. The organisation EMAS ([www.emas-international.de](http://www.emas-international.de)) has worked to develop manual drilling and handpump technologies in Bolivia, and it is estimated that over 20,000 manually-drilled well systems have been installed in households throughout Bolivia using their methods (Danert, 2009). Additionally, hand-auger drilling techniques have been largely promoted by a Mennonite missionary organization for several decades, and ‘Water for All International’ developed the ‘Baptist’ drilling technique and a low-cost water pump in Bolivia. EMAS Pumps (and variations) and Baptist Pumps are commonly used at the household level in numerous regions across the country.

### *EMAS Technologies in Bolivia*

To encourage families to use EMAS water and sanitation technologies, and to incrementally improve their household infrastructure, EMAS has adopted a strategy which focuses on the ‘added value’ of EMAS technologies towards improving household living conditions and lifestyles. This added value comes from the higher level of service that is provided largely through having a reliable water system and water piped to taps in the house. EMAS implements its strategy primarily through the training of local independent technicians from various parts of Bolivia (subsidized by EMAS), as well as through the broadcasting of EMAS training videos on Bolivian television and on the internet. In their work outside of Bolivia, EMAS typically partners with other organisations and local/national governments for implementation, and promotes the same strategy through trainings and assessment trips.

## ACCELERATING SELF SUPPLY

### Financing & scaling-up affordable rural water technologies

**EMAS manual water pumps** are used to lift either groundwater from wells or rainwater from underground storage tanks. The EMAS Pump (also known as the Flexi-Pump, or ‘Bomba Flexi’ in Spanish) is a manually-operated pump capable of lifting water from depths of more than 30 metres (Buchner, 2006). Originally developed in the 1980s by Wolfgang Buchner, the EMAS Pump has been marketed extensively for local construction and use at the household level in Bolivia, and to a lesser extent in other developing countries, mostly in South and Central America (Akvo, 2012). The EMAS Pump has also been introduced on a relatively small-scale in several countries in sub-Saharan Africa, including recently in Sierra Leone (Bunduka, 2013).

The EMAS Pump consists of an outer PVC pipe (‘pump cylinder’ - typically of 20-40mm diameter) with a one-way foot valve on its lower end, and a smaller-diameter inner PVC pipe (‘piston pipe’ – typically of 16mm diameter) with a one-way piston valve on its low-er end. A rubber gasket on the outside of the piston valve provides a seal with the pump cylinder. The upper end of the piston pipe attaches to a handle, which is commonly made of galvanized iron. The pump is installed in a well or tank so that the piston valve and foot valve are below water. The pump cylinder remains static, and when the handle (piston pipe) is lifted, suction force causes the foot valve to open (while the piston valve remains closed), and water enters from the well into the pump cylinder. When the handle is then lowered, the foot valve closes and compression pressure causes the piston valve to open, and water flows into the piston pipe. *Figure 2(a)* shows how the EMAS pump valves function. *Figure 2(b)* and *Figure 2(c)* show EMAS Pumps installed on groundwater sources.

The simple design of the EMAS Pump, using materials commonly available in developing countries (e.g. PVC pipes, glass play marbles in the pump valves, and rubber cut from a used car tire) and basic tools, allows for the pumps to be fabricated by trained technicians in many developing communities. The ability of the EMAS Pump to lift water from significant depths to heights above the pump head (e.g. for pumping to elevated household tanks, reservoirs at higher elevations, or for installing multiple pumps on wells) adds to the pump’s value. The EMAS Pump is designed for use on household systems (up to 5-6 families, or 30 users maximum), and is not meant to be used as a community pump.

**EMAS manually-drilled well systems** are primarily promoted for domestic water use. EMAS teaches a few different methods for manually drilling wells, with the most common (the ‘Standard EMAS’ method) incorporating percussion, jetting, and rotation drilling techniques. The standard EMAS method is capable of drilling to depths of up to 100m, through sand, clay, and thin layers of soft rock, with a team drilling with a trained technician commonly able to drill 20-30 metres per day (Buchner, 2011).

Additionally, EMAS promotes household rainwater harvesting systems (RWHS). **EMAS household RWHS** consists of a catchment area, which is commonly the roof of a house, to which a gutter/drainage system is attached, which guides the rainwater that falls onto the roof to a simple filter (to catch debris) and onwards to a storage tank. EMAS storage tanks can either be below-ground or above-ground. Where conditions permit, it is generally preferred to construct a below-ground tank, as the material costs are considerably less due to the walls of the underground tank being supported by the surrounding soil. From an underground tank, water can then be pumped to the surface (or above, to household or other elevated tanks) using a manual EMAS Pump.

## ACCELERATING SELF SUPPLY

### Financing & scaling-up affordable rural water technologies



Figure 2: (a) Mode of operation of EMAS Pump: Valves function on pump upstroke [far left] and pump downstroke [left] (adapted from Buchner, 2006); EMAS Pump installed on a manually drilled well [middle, Photo: EMAS]; EMAS Pump in use, as one of several installed on a hand-dug well [right, Photo: M. MacCarthy]

#### Methodology

The research included an overview of EMAS low-cost water supply technologies and EMAS's approach to improving water supply, and provides an independent assessment of select EMAS water supply technologies as implemented at the household level in rural areas of Bolivia. Field data were gathered during two trips to Bolivia, in March-April 2011 and June-July 2011.

Qualitative data collection involved mixed methods, consisting of surveys, semi-structured interviews, and observation/inspection. Research was carried out in 3 regions of Bolivia (Santa Cruz, Beni, and La Paz). Surveys at the household level of users of EMAS water supply technologies provided the primary data, with questions focused on water and sanitation infrastructure/technologies used by the household; water usage; and costs and responsibilities for installation and repair of EMAS technologies. Semi-structured interviews were conducted with rural water supply technicians and organisations involved in the promotion, construction, installation, and/or repair of EMAS household water supply systems. Household water and sanitation infrastructure was inspected for all surveyed households, including a sanitary risk inspection of the water system, and installed manual pumps were tested to determine state of functionality.

#### Main Results and Discussion

The primary findings of the study (MacCarthy et al., 2013b) include:

1) *EMAS Pumps have a high rate of functionality, and low capital, maintenance costs.* A very high percentage of households in the studied contexts in Bolivia were found to have functional EMAS Pumps. Visits to almost eighty households that use EMAS Pumps in their primary water supply systems (manually-drilled wells or RWHS) showed nearly all pumps to be operational (78 out of 79). As shown in *Figure 3*, 84% of the EMAS Pumps surveyed were found to be functioning normally (i.e. without significant issues, and with water discharging normally), including 72% of pumps (13 out of 18) that were reported to have been installed 11 or more years ago. The cost of a new EMAS Pump, to be installed to 15 metres depth, was reported by local technicians to be US\$ 30-45 (for pump material and construction costs only, i.e. not including well drilling).

2) *A majority of EMAS household water systems are unsubsidized.* 62% (53 out of 86) of EMAS water supply systems surveyed were reported to have been paid for fully by the household, without any subsidy or

## ACCELERATING SELF SUPPLY

### Financing & scaling-up affordable rural water technologies

loan. Loans were reported to have been used to help pay for systems by 5% of households (4/86), with 3 households having received a loan from a bank or official lender, and 1 household having received a loan from a relative. 28% of households reported receiving subsidies to partially fund their EMAS water systems, and 6% reported not knowing specifically how their water system was financed.

3) *Considerable potential for RWHS.* The use of EMAS-style RWHS in Bolivia was very limited at the time of the field research, with the only area with significant uptake of the technology being the villages surrounding the EMAS training center in La Paz region. However, in surveyed areas where EMAS-type RWHS are not in existence there was evidence of potential for household RWHS, as it is commonly practiced in very basic form (e.g. catching rainfall off of roofs using buckets or larger containers). Most (80%) of the houses surveyed without EMAS RWHS had either corrugated metal or clay shingle roofing, both of which are very suitable surfaces for rainwater catchment.

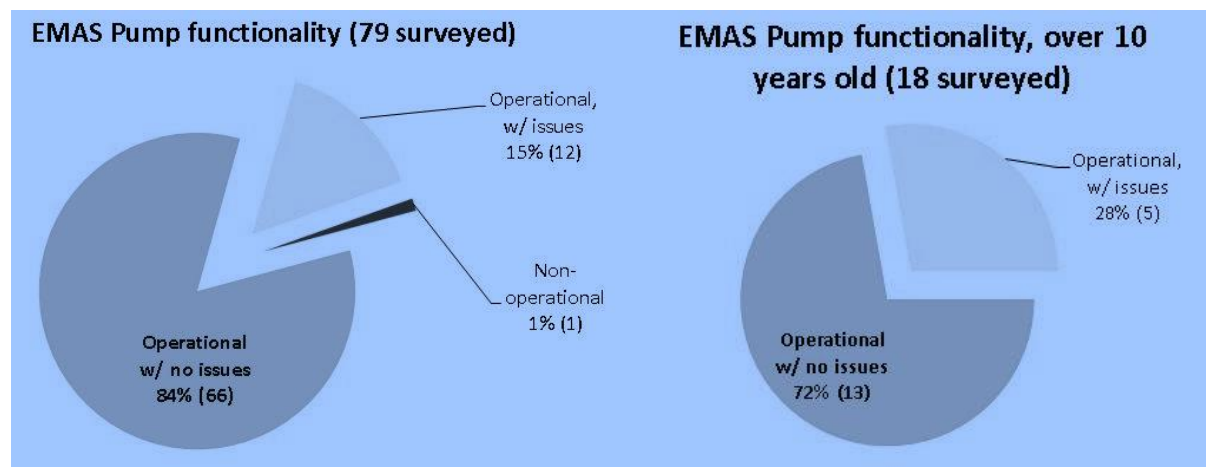

**Figure 3: (a) Operational state of all EMAS Pumps surveyed [left]; (b) Operational state of subset of EMAS Pumps installed 11 or more years ago [right]**

### Case Study 3: EMAS Pump Technical Comparison with Rope Pump

This study highlights research carried out by the University of South Florida. Further information can be found in MacCarthy et al., 2016 (*in review as of May 2016*) and Carpenter, 2014.

#### Context

A comparative analysis was carried out in Uganda with two versions of the EMAS Pump (*Figure 4(a)*) and two versions of the Rope Pump. The Rope Pump (*Figure 4(b)*), which has been most successfully marketed as a household-level pump in Nicaragua, was selected for comparison with the EMAS Pump because the Rope Pump is very well-known in the international rural water supply sector. It has also been introduced in many other developing countries over the past fifteen years, with some success in Tanzania (ACRA, 2012) and varying degrees of success in other countries (Sutton and Gomme, 2009).

Over the past decade, there has been considerable attention paid to the Rope Pump as a low-cost water supply option for developing communities (e.g. Alberts, 2004; MacCarthy 2004; Harvey and Drouin, 2006; Sutton and Gomme, 2009), while little independent documentation has been published related to the EMAS Pump. A 2004 World Bank study compared and summarized experiences with the Rope Pump and the EMAS Pump in Honduras (Brand, 2004). However, while providing a comparison of various attributes of the EMAS Pump and Rope Pump, including initial cost, function and reliability, and overall sustainability, that publication did not present any scientific data on the technical performance of the two pumps. The Honduras study and the Bolivia study (*Case Study 2*) highlight multiple positive qualities of the EMAS Pump (e.g. low-cost, feasibility of local-manufacture in developing communities, and an ability for households to maintain its operation) that lend it to potentially be suitable as a Self-supply water-lifting option in sub-Saharan Africa.

ACCELERATING SELF SUPPLY

Financing & scaling-up affordable rural water technologies

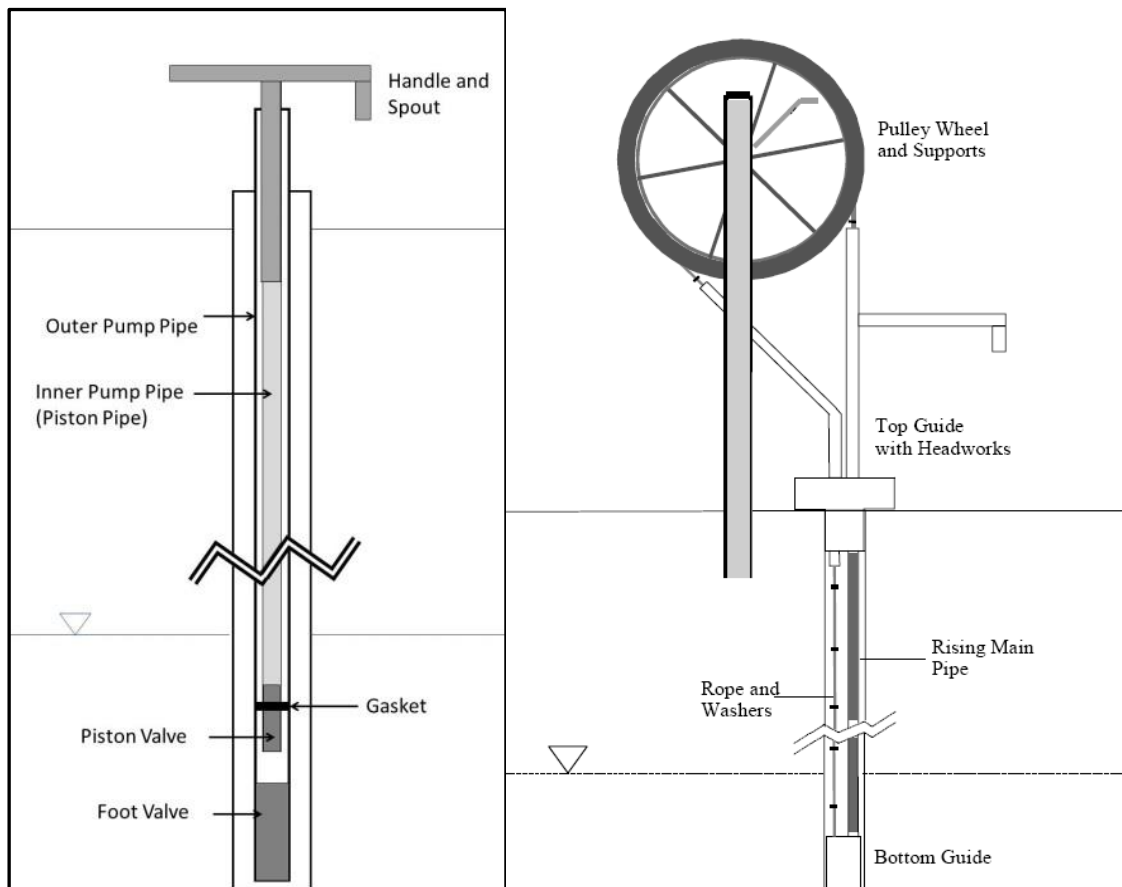

Figure 4: (a) Components of an EMAS Pump, installed on a drilled well (MacCarthy et al., 2016) [left], (b) Rope Pump components installed on a drilled well (MacCarthy, 2004) [right].

Methodology

Two variants of each pump were tested by a male and female user. Pumping trials took place at five separate locations in northern Uganda (in Kitgum and Gulu Districts) over a one-month period in September-October 2013, on wells with static water depths ranging from 5m to 28m. Pumping rates were averaged based on two trials, and normalized to take account for the amount of energy expended by the users during pumping (which was calculated using measured heartrate and established energy expenditure equations). Material costs for each pump are based on retail prices in Kampala, Uganda, in late-2013.

Main Results and Discussion

1) *The EMAS Pump had similar pumping rates as the Rope Pump at depths of less than 20 m, for the most common versions of the pumps, and lower pumping rates at deeper depths*

Results demonstrated that the EMAS Pump with a 20-mm diameter pumping pump can perform similarly to the Rope Pump with a 20-mm pipe, in terms of pumping rate at depths less than 20 m, but less so at deeper depths. For the versions of the EMAS Pump and Rope Pump with 25-mm diameter pipes, the pumping rates for the EMAS Pump were significantly less than for the Rope Pump. Normalized pumping rates accentuated differences between the EMAS Pump and Rope Pump, as shown in Figure 5.



## ACCELERATING SELF SUPPLY

### Financing & scaling-up affordable rural water technologies

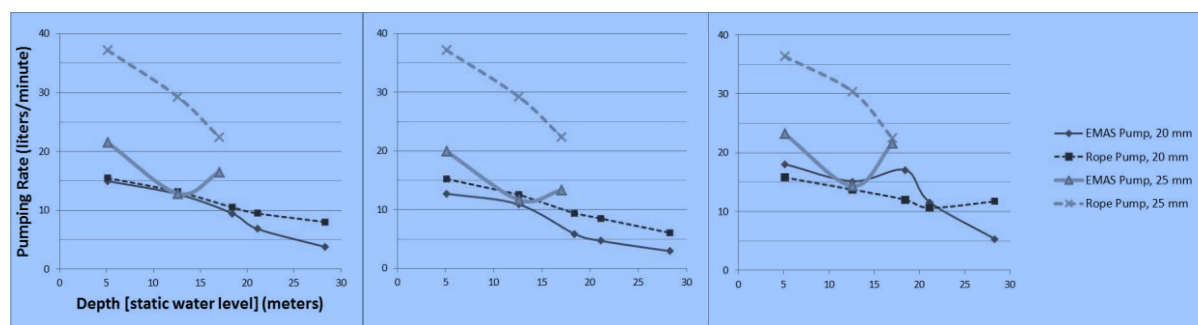

Figure 5. Average pumping rates at various depths with EMAS Pump pumping rates normalized for energy expenditure, for: (a) adult female and adult male subjects; (b) adult female subject, and (c) adult male subject. (MacCarthy et al., 2016)

### 2) EMAS Pump materials cost significantly less than Rope Pump

Cost of materials to construct the EMAS Pump were 21 to 60 percent lower than for the Rope Pump (Table 1).

Table 1: Material costs for EMAS Pump compared to the Rope Pump in Uganda (costs in US\$, based on retail prices in Kampala in late-2013).

Static Water Level (m)	EMAS 20-mm	Rope Pump 20-mm	EMAS 25-mm	Rope Pump 25-mm
5	\$9.10	\$44.2	\$12.5	\$44.7
10	\$13.6	\$46.9	\$19.5	\$47.9
15	\$18.2	\$49.7	\$26.0	\$51.9
20	\$22.7	\$52.4	\$32.8	\$54.5
25	\$27.2	\$55.1	-	-
30	\$31.8	\$57.8	-	-

### 3) Construction requirements for the EMAS Pump are considerably less than for the Rope Pump

If costs for pump fabrication were to be assessed and added to pump material costs, the total difference in costs between the Rope Pump and the EMAS Pump would certainly increase because the Rope Pump requires extensive welding and cutting that takes time, specialized skill, and incurs electricity costs. In contrast, the EMAS Pump can be constructed with a few simple hand tools such as a hand saw, files, wrenches, files, and PVC glue, and a heat source such as a gas flame or a charcoal stove.

## Conclusions and Recommendations

Conclusions and recommendations are summarized through revisiting the studies' four research questions:

### 1. What improvements can be made to the Pitcher Pump system in Madagascar to improve the quality of the product (including reliability, pumping rates, and/or quality of extracted water)?

It was found that Pitcher Pump systems are widely used in the research area, and are shown to provide reliable and convenient access to water at a low cost relative to household connections to the piped water system. The Madagascar Pitcher Pump market is believed to be the most significant documented example of an unsubsidized household handpump market in sub-Saharan Africa (MacCarthy et al., 2013a). As the systems are easily maintained/repared by families or local technicians, recommendations for improvement focus on improving the quality of the extracted water. It is recommended that leaded components not be used in pump construction. Additionally, it is recommended that wellhead protection is installed around the wells, and further research is exploring options for low-cost well aprons.

### 2. Are low-cost water supply systems developed in Bolivia (EMAS technologies) suitable, affordable options for household water supply (Self-supply) for developing communities in sub-Saharan Africa?

## ACCELERATING SELF SUPPLY

### Financing & scaling-up affordable rural water technologies

Households are able to maintain low-cost EMAS Pumps, with repairs commonly done by local technicians or household members, and in some cases the same EMAS Pumps have been used for more than a decade.

Given their low cost and conduciveness to construction and repair by local technicians, these technologies offer considerable potential for success in accelerating self-supply in sub-Saharan Africa. The potential includes using the EMAS Pump on existing or new household manually drilled or hand-dug wells (with the possibility of installing multiple pumps on the same hand-dug well), manual drilling of wells using EMAS methods, upgrading of such systems as appropriate/feasible (e.g. pumping through hoses or pipes to a tank/reservoir), and RWHS.

*3. Would the EMAS Pump be an effective, less-costly alternative to the family Rope Pump, potentially offering new opportunities for households or small groups of families in sub-Saharan Africa to improve their private water supplies?*

The technical comparison of the EMAS Pump and the Rope Pump concluded that, based on its relative low-cost, similar pumping rates to common versions of the Rope Pump when pumping from depths less than 20m, and the minimal resources needed to construct it, the EMAS Pump has potential for success in household water supply systems in sub-Saharan Africa. Combined with the conclusion from the EMAS study in Bolivia (*Case Study 1*), which showed a high rate of functionality among surveyed household EMAS Pumps in rural areas of Bolivia, it is believed that there is considerable potential to introduce the EMAS Pump as a very low-cost option for sustainable Self-supply systems in sub-Saharan Africa.

*4. Based on the results of Research Questions 1 through 3, what recommendations can be offered to improve sustainable low-cost water supply systems for use at the household level in developing contexts in sub-Saharan Africa?*

Further research, much of which is now in progress, is needed to maximize the potential improvements to Pitcher Pump systems, determine the key factors of the systems that Pitcher Pump consumers and producers value, and determine the feasibility of household water treatment and rainwater harvesting Self-supply options to improve access to drinking water. As the research advances, more information on the success and sustainability of this market will be valuable to developing and supporting household water supply markets in other sub-Saharan African environments.

The EMAS Pump, which was shown to be sustainable over the medium- to long-term in the studied Latin American context, offers key attributes (i.e. lower-cost, easier to construct) that may allow it to have success as an unsubsidised household pumping option in a wider range of contexts than the Rope Pump has in sub-Saharan Africa.

### Acknowledgements

The Pitcher Pump study was conducted as part of a partnership between the University of South Florida (Tampa) and RANO HamPivoatra (Water for Progress), a past USAID-funded project in Madagascar implemented by a consortium led by the NGOs CRS and CARE. A portion of that work was supported by the National Science Foundation under Grant No. 0965743. The authors thank Ms. Marie Onnie Razafikalo for assistance with field data collection in Madagascar. The EMAS-Bolivia study is based upon work supported by the National Science Foundation under Grant No. 0851910. Thanks to Wolfgang Buchner (EMAS) and Patricia Vargas (Universidad Tecnológica Boliviana) for their support. For the EMAS Pump – Rope Pump study the authors thank Patrick Woodson and Dustin Bales for their support in field data collection, as well as Mercy Corps and Peace Corps for logistical support. That study is based upon work supported by the National Science Foundation under Grant No. DUE 0965743. Most importantly, the authors wish to thank all of the local communities members in Madagascar, Bolivia, and Uganda that graciously participated in the research.

### References

- Akers, D.B. (2014). *Lead (Pb) contamination of water drawn from pitcher pumps in eastern Madagascar*. Master's Thesis. University of South Florida, Tampa, Florida, USA. <http://scholarcommons.usf.edu/etd/4975>
- Akers, D.B.; MacCarthy, M.F.; Cunningham, J.A.; Annis, J.; Mihelcic, J.R. (2015). *Lead (Pb) contamination of self-supply groundwater systems in coastal Madagascar and predictions of blood lead levels in exposed children*. Environ. Sci. Technol., 49 (5), 2685–2693.
- Akers, D.B.; MacCarthy, M.F.; Cunningham, J.A.; Mihelcic, J.R. (2016) (*In review*). *Estimates of blood lead levels (BLLs) for children in coastal Madagascar: Accounting for dietary uptake of lead (Pb) from contaminated cooking water*.

## ACCELERATING SELF SUPPLY

### Financing & scaling-up affordable rural water technologies

- Akvo (2012). *EMAS*, Akvopedia. <http://www.akvo.org/wiki/index.php/EMAS>
- Alberts, J.H. (2004). *The rope pump: An example of technology transfer*, Waterlines. 22(3): pp. 22–25.
- Buchner, W. (2006). *EMAS: Water for everybody: A selection of appropriate technologies to be used for drinkable water*. 5th Ed. EMAS, La Paz, Bolivia.
- Buchner, W. (2011). *EMAS-Bolivia*, Personal conversations, Puerto Perez, Bolivia, March 2011.
- Bunduka, E. (2013a). *Sierra Leone pilots EMAS technologies – Welt Hunger Hilfe*, Welt Hunger Hilfe. Briefing Paper.
- Carpenter, J.D. (2014). *An assessment of the EMAS Pump and its potential for use in household groundwater systems in Uganda*. Master's Thesis. University of South Florida, Tampa, Florida, USA. <http://scholarcommons.usf.edu/etd/4996>
- Coloru, B, Mgay, S, and Pozzi-Taubert, R. (2012). *A comparative study between “Rope pumps” and conventional piston pumps on water quality and other sustainability parameters*. Appropriate technologies for rural water supply, Fondazione ACRA-CCS, SHIPO.
- Danert, K. (2009). *Hand drilling directory*. Rural Water Supply Network Field Note No. 2010-4. Available on <http://www.rural-water-supply.net/en/resources/details/156>
- Harvey, P.A. and Drouin, T. (2006). *The case for the rope-pump in Africa : A comparative performance analysis*. *Journal of Water and Health*. 04 (4). pp. 499–510.
- Harvey, P., and R. Reed (2007). *Community-managed water supplies in Africa: Sustainable or dispensable?* *Community Dev. J.* 42(3), 365.
- MacCarthy, M.F. (2004). *The Development of the Rope and Washer Pump for use with tubewells in Maputaland, South Africa*. Master's Thesis. University of Southampton, Southampton, England.
- MacCarthy, M.F., Annis, J.E. and Mihelcic, J.R. (2013a). *Unsubsidised self-supply in Eastern Madagascar*. *Water Alternatives*, 6(3): 424–438. <http://www.water-alternatives.org/index.php/alldoc/articles/vol6/v6issue3/226-a6-3-6/file>
- MacCarthy, M.F., Buckingham, J.W., and Mihelcic, J.R. (2013b). *Increasing access to low-cost water supplies in rural areas: EMAS household water supply technologies in Bolivia 2013-4*. St. Gallen. <http://www.rural-water-supply.net/en/resources/details/518>
- MacCarthy, M.F. (2014). *Low-cost household groundwater supply systems for developing communities*. University of South Florida, Tampa, Florida, USA. <http://scholarcommons.usf.edu/etd/5261>
- MacCarthy, M.F., Carpenter, J.C., and Mihelcic, J.R. (2016) (*In press*). *Low-cost water-lifting from groundwater sources: A comparison of the EMAS Pump with the Rope Pump*. *Hydrogeol. J.*
- Mihelcic, J.R.; Fry, L.M.; Myre, E.A.; Phillips, L.D. and Barkdoll, B.D. (2009). *Field guide in environmental engineering for development workers: Water, sanitation, indoor air*. Reston, VA: ASCE Press.
- Missen, C. (2003). *Drilling wells by hand*, Wellspring Africa. <http://www.wellspringafrica.org/WebManual/default.htm>
- JMP (2015). *Progress on sanitation and drinking water. 2015 update and MDG assessment*. New York. [http://www.wssinfo.org/fileadmin/user\\_upload/resources/JMP-Update-report-2015\\_English.pdf](http://www.wssinfo.org/fileadmin/user_upload/resources/JMP-Update-report-2015_English.pdf)
- Sutton, S. (2009). *An introduction to Self supply: A case study from Ethiopia 2010*. Rural Water Supply Series Field Note No 2010-2. WSP and RWSN.
- Sutton, S. and Gomme, J. (2009). *Transferring the rope pump to Africa: A long and winding road?* *Waterlines*. 28 (2). pp. 144–160.
- USAID (2010). *Madagascar water and sanitation profile*. [www.washplus.org/sites/default/files/madagascar2010.pdf](http://www.washplus.org/sites/default/files/madagascar2010.pdf)
- Wahlstrom-Ramler, M. (2014). *Drinking water in the developing world: Sources of fecal contamination in Pitcher Pump systems and measurement alternatives*. Master's Thesis. University of South Florida, Tampa, Florida, USA. <http://scholarcommons.usf.edu/etd/5146>
- Wohlraabe, A.A. (2015). *The development of a low-cost, lead free wellpoint drilling system for use in household well systems in coastal areas of Madagascar*. Master's thesis. Mercer University, Macon, Georgia, USA.

## ACCELERATING SELF SUPPLY

Financing & scaling-up affordable rural water technologies

# Multiple Use of water Services (MUS) – water for the home and for farming

Type: Short Paper

**Authors :** *Dr. Lakhdar Boukerrou, Regional Director, USAID WA-WASH; Research Associate Professor, Florida International University, lboukerr@fiu.edu, +226 25 37 53 08, Edouard Tiendrebeogo, Assistant Coordinator, USAID WA-WASH Program, + 226 25 37 53 08*

### Abstract/Summary

Access to water remains a big challenge for rural populations in Burkina Faso and to address this challenge, the USAID WA-WASH Program focused its efforts on low cost water technologies in 21 villages. These water technologies including, rope and bicycle pumps are human operated. They are simple, reliable, and manufactured locally. They can be used for both domestic water consumption and productive activities including gardening, agricultural production, and livestock. Most importantly, they are made locally, use local materials, provide clean and safe water, and are affordable to rural households. A low cost water technology system consists of a pump and a well. The depth of the well can reach up to 40 meter and the pump is equipped with a rope, a pulley wheel, and a piston. This paper provides insights and solutions for water technologies which aim to be dependable, easy to operate, cost effective, and with a high probability of ensuring a sustainable access to water in rural areas.

Keywords: Low cost water technologies; Baseline survey; Rope pump; Bicycle pump; Beneficiaries; Sustainability; Clean and safe water

### Introduction

Access to water remains a big challenge for rural populations in Burkina Faso. Despite efforts from the government and non-government organizations (NGOs), the rate of access to water in urban and rural areas remains low. As of December 2011, 26% of the urban population had taps on their premises, 70% were relying on other improved facilities, and 4% on unimproved facilities. In rural areas, 74% of the population were relying on improved facilities, 21% on unimproved facilities, and 5% on surface water (JMP report, 2013). Low access rates to drinking water are the result of inadequate investments, lack of human capacity, increases in large scale and irrigated agriculture, and limited water resources. These major challenges are exacerbated by climate change effects and an increased deterioration of watersheds.

In most West African countries including Burkina Faso, the MDG goals for water and sanitation have not been reached. Thus, it became necessary to include water and sanitation in the SGDs. Most importantly, it is crucial to think about a different approach which could bring clean water to the rural populations at a low cost and within a short period of time. Some of these populations have been waiting for years to have access to water and despite the planning for the next 15 years, it might take a long period of time before they have access to clean water.

To address this issue, the USAID West Africa Water Supply, Sanitation, and Hygiene Program (USAID WA-WASH) introduced in 2011 the low cost water technologies whilst taking into account the aspect of multiple use of water services in rural areas. The cost per unit of wells with rope pumps and bicycle pumps is between 600 000 and 700 000 CFA Franc and they were subsidized by the Program to the tune of 80%. The main features of these technologies is that the pumps equipped with a rope is placed over the well. In some instances, the wells have been deepened and an apron was installed before the installation of the pump. These low cost technologies were introduced in a total of 28 villages spread across three regions in Burkina Faso (Centre, Centre-Ouest, and Boucle du Mouhoun).

## ACCELERATING SELF SUPPLY

### Financing & scaling-up affordable rural water technologies

Through this low cost water technologies initiative, the main objective of the USAID WA-WASH Program was to increase sustainable access to clean and safe water in the rural areas of Burkina Faso.

#### Description of the Case Study – Approach or technology

On September, 2015, the member States of the United Nations has committed to achieve universal and equitable access to safe and affordable drinking water for all by 2030 (United Nations General Assembly, 2015) through the newly adopted Sustainable Development Goals (SDGs). For the USAID WA-WASH Program, low cost water technologies are a great opportunity to help achieve this goal and will provide clean and safe water right away until rural population have access to more permanent infrastructure. With an average depth of 20 meters, an upgraded traditional well with a rope pump can serve up to 75 people. The depth of the well can reach up to 40 meter. Rope and bicycle pumps are human operated. These pumps are simple, reliable, and manufactured locally. They can be used for both domestic water consumption and productive activities – such activities include gardening, agricultural production, and livestock - (USAID WA-WASH, 2013). Most importantly, the pumps are made of local materials, they are close and affordable to rural households, and provide clean and safe water; thus, eliminating not only the need to transport and store water but also drinking water contamination risks.

Prior to introducing the low cost water technologies in the selected communities, a baseline survey was conducted in nine villages in September 2012 and a second baseline survey was conducted in 12 additional villages in November 2014. Both baseline surveys showed that households rely on different water sources for their domestic needs depending on the seasons (dry versus rainy season). Despite the existence of some improved water points, most households prefer to use the hand-dug wells within their compounds. Consequently, the main water sources used during the rainy season are unprotected traditional wells (54.5% of the surveyed households), boreholes with hand pumps (37.1%) and unprotected large-diameter wells (11.6%). When most of the unimproved water points dry up during the dry season, the main water sources used are boreholes with hand-pumps (57.4%), followed by unprotected traditional wells (39.2%), and unprotected large-diameter wells (11.6%). Within the nine villages, the community water points include 63 traditional wells (51 functional and 12 non-functional), two protected large-diameter wells, and 42 unprotected large-diameter wells.

Based on the baseline survey findings detailing how people were actually using water, USAID WA-WASH decided to focus on a household/self-supply approach rather than a community approach to provide water. The solution adopted includes the upgrading of existing private hand-dug wells by equipping them with rope pumps and the construction of brand new wells with rope and bicycle pumps.

In installing water facilities in rural areas, proper siting matters. Thus, to pinpoint the right place to dig a well equipped with a rope or bicycle pump, the Program conducted an assessment of potential pollution sources in the surrounding areas and ensured that all water facilities were installed away from polluted areas. During the assessments, the community members were invited to help delineate sacred areas, open defecation zones, and existing water point locations. This information was used to site rope and bicycle pumps in the most appropriate locations. The water facilities were sited at least 15 meters from potential pollutant sources including landfill areas, latrines, and animal pens. In the siting process, the Program also opted not to locate the water facilities within wetlands or protected areas.

To manufacture, maintain, and repair the low cost water facilities, the Program trained local drillers, pumps manufacturers and repairers on how to properly construct low cost water pumps and integrate quality standards and safety measures. To ensure that the pumps manufacturing activities meet program standards, the Program trained the selected craftsmen on business development services and equipped them with pump manufacturing tools. The Program also conducted trainings for community members on water facilities maintenance and formal agreements were made with landlords and traditional authorities in Burkina Faso to prevent dispute over the lands and the water facilities installed by the Program. To maintain proper hygiene around water points, USAID WA-WASH constructed platforms

## ACCELERATING SELF SUPPLY

### Financing & scaling-up affordable rural water technologies

to drain excess water into cesspools. Per the sustainability check recommendations and water quality assurance plan, the water facilities were protected by installing a fence or constructing a small wall around the facilities. Public outreach on drinking water handling at the household level was also provided to prevent pollution around the water facility which could lead to contamination of the water point.

### Main results and lessons learned

Since its inception, USAID WA-WASH and its partners including the municipalities of the target districts have worked hard to promote low cost water technologies across Burkina Faso during the Phase I of the Program which ran from 2012 to 2015. This joined effort has permitted the construction of 197 brand new low-cost water facilities and the upgrading of 12 conventional boreholes within the multiple use of water services communities in Burkina Faso. As a result, 16,589 people gained access to an improved drinking water source. Per USAID WA-WASH sustainability strategy, 134 water points were fenced and water point management committees consisted of hygienists, treasurers, and repairers were established for all water points constructed in order to ensure proper operation and maintenance of the facilities. Since then, the hygienists have been raising awareness on good sanitation practices around the water points and the treasurers have been collecting water user’s monthly financial contributions. In the event of a breakdown the money collected by the treasurers is used to repair the pumps. Through this activity, the Program increased the percentage of households using an improved drinking water source in the target areas by 26 percent as compared to the baseline survey. As part of the promotion of the multiple use of water services activities, USAID WA-WASH strengthened the capacity of three local non-governmental organizations (NGOs). The Program worked with Organisation Catholique pour le Development et la Solidarité (OCADES) and Action Micro Barrage (AMB) to install low-cost boreholes in their intervention areas and a technical assistance was provided to BARKA Foundation to install four conventional boreholes in the Eastern region of Burkina Faso. As a result of the support provided to the three local partner NGOs, 21 additional low-cost water facilities were installed across six communities. This increased to 197 the total number of low cost drinking water facilities installed under the multiple use of water services activities in Burkina Faso.

Lessons learned from the implementation of the low cost water technologies approach during the Program Phase I activities include good timing in the improvements of traditional wells. The construction of brand new wells equipped with rope or bicycle pumps during the rainy season is likely to lead to a wrong depth because of the high water table. Therefore to have long lasting water points and ensure water availability, the dry season is the appropriate period to improve traditional wells. For the beneficiaries to take ownership of new technologies, it is also essential to use the ones which parts are cheap and easy to find. Most importantly, the cultural and socio-economic context of the target country must be considered in order to ensure a wide buy-in of the selected technologies.

As part of its Phase II (2016 – 2017) activities, USAID WA-WASH is monitoring its past activities in 32 villages of Burkina Faso in order to ensure sustainability. This monitoring activities include the performance of the rope and bicycle pumps installed as well as the quality of the water they provide. From March 10 – 19, 2016 and April 20 – 29, 2016 the monitoring and evaluation (M&E) team went to 18 villages in three regions (Boucle du Mouhoun, Centre, and Centre-Ouest) of Burkina Faso. During these field visits, the M&E team checked 63 water points of which 54 were functional (functionality rate of 86%) after more than one year of operation. Water samples have been also taken and they are being analyzed by a laboratory in Ouagadougou.

The monitoring field visits also revealed that the demand for rope and bicycle pumps continued since the end of Phase I. Between 2012 and 2015, the USAID WA-WASH Program encouraged water point improvements in various communities by subsidizing boreholes (digging, aprons, etc.); and urged the beneficiaries to purchase the rope pump (approximate cost of 75,000 F CFA) fabricated by manufacturers in four cities of Burkina Faso – the manufacturer in Ouagadougou sold 117 pumps (46 sold directly by the manufacturer), the one in Boromo sold 55 pumps (3 sold directly by the manufacturer), and the manufacturer from Koudougou sold 76 pumps (2 sold directly by the manufacturer). Since July 30, 2015,

## **ACCELERATING SELF SUPPLY**

### **Financing & scaling-up affordable rural water technologies**

the end of the Program's subsidies, the pump manufacturers sold 51 pumps (Ouagadougou = 24; Boromo = 1; Koudougou = 7). A new pump manufacturer located in Dedougou started operations in December 2014 and since then, he sold 19 pumps without the Program support, another example of the sustainability of the USAID WA-WASH approach.

One of the problems observed during the monitoring field visits concerns the break of the rope itself. It appears that the rubbing of the rope against the metal is damaging the rope. As a result of this problem, out of 63 water points visited, the rope of 52 pumps have been already replaced. From May 4 – 5, 2016, USAID WA-WASH organized a brainstorming session between the pumps manufacturers, repairers, and the beneficiaries to find a solution to this problem.

### **Conclusions and Recommendations**

Since its inception in 2011, USAID WA-WASH has designed and implemented its activities with sustainability in mind. On the basis of the two baseline studies conducted in Burkina Faso, the USAID WA-WASH Program and its partners have opted to rely on low cost water technologies to ensure sustainable access to water in 28 villages located in the Centre, Centre-Ouest, and Boucle du Mouhoun regions. This option paid off despite the numerous challenges faced by the Program during the implementation of the low cost water technologies strategy. The Program met or exceeded most of its life-of-project targets in water supply, as evidenced by the installation of 197 low cost water facilities and the upgrading of 12 conventional boreholes across Burkina Faso. On top of that, the low cost water technologies initiative allowed 16,589 people living in the Program intervention regions to have access to clean and safe water. However, to ensure the sustainability of these water facilities, it is necessary to continue to monitor them, record lessons learned and share them with relevant public and private WASH stakeholders. Most importantly, to ensure that the WASH sector as a whole addresses the need of the rural and urban populations it is critical that the capacity of the major WASH regional institutions be strengthened.

### **References**

- United Nations General Assembly (October 2015). Transforming our world: the 2030 Agenda for Sustainable Development report. Retrieved from [http://www.un.org/ga/search/view\\_doc.asp?symbol=A/RES/70/1&Lang=E](http://www.un.org/ga/search/view_doc.asp?symbol=A/RES/70/1&Lang=E)
- USAID WA-WASH (February 2016). Briefing notes on USAID WASH Phase I accomplishments in Burkina Faso. Performance period: August 2011 –December 2015
- USAID WA-WASH (June 2016). Briefing notes on USAID WA-WASH Phase II accomplishments. Performance period: January 1– June 30, 2016
- USAID WA-WASH (June, 2016). Workshop on the technical sustainability of WASH technologies introduced during the Phase I of the USAID WA-WASH Program report.
- USAID WA-WASH (March 2013). Description of identified promising technologies/options for increasing domestic and productive water supply in Burkina Faso report.
- USAID WA-WASH (October 2015). Annual report. Performance Period: October 1, 2014 – September 30, 2015
- WHO & UNICEF (2013). Rapport sur le progrès en matière d'assainissement et d'alimentation en eau. Retrieved from [http://www.wssinfo.org/fileadmin/user\\_upload/resources/JMP2013-French\\_web.pdf](http://www.wssinfo.org/fileadmin/user_upload/resources/JMP2013-French_web.pdf)

## ACCELERATING SELF SUPPLY

### Technology Applicability Framework (TAF) experiences

#### 3.4.3 Technology Applicability Framework (TAF) experiences

---

## Supporting service delivery and business innovation through TAF application

---

Type: Short Paper

**Authors** André Olschewski, Skat Foundation, Switzerland, [andre.olschewski@skat.ch](mailto:andre.olschewski@skat.ch); +41 71 228 54 54; Vincent Casey, WaterAid, UK, [vincentcasey@wateraid.org](mailto:vincentcasey@wateraid.org) +44 207 793 4932

### Abstract/Summary

The Technology Applicability Framework (TAF) is a participatory, decision support tool for assessing the sustainability, scalability and relevance of water, sanitation and hygiene (WASH) technologies in a specific context. After 2013 when WASHTech project had ended the TAF has been promoted widely and applied without much external support in different contexts to a wide range of WASH technologies and service delivery models. Experiences show that the TAF is very much appreciated as a comprehensive framework which supports transparency and accountability. However as the TAF is a generic tool it needs contextualisation for each application. Being quite a complex tool the application of the TAF needs sufficient resources and capacities for proper preparation and facilitation to achieve expected outcomes. More cases and follow up are needed to further develop the tool for business development and to assess its impact on innovation in the WASH sector.

### Introduction

Numerous blockages stand in the way of WASH technologies reaching their full potential and being taken to scale. Whilst some technologies are widely used, others languish in a zone of endless piloting. Weak feedback loops between service users and implementers mean that problems can persist for decades without any resolution. Implementers can sometimes hold very different views about the merits of a particular technology to the people who use them as part of a service. This means that changes are necessary to improve a technology can go unimplemented for long periods of time. The overall result is poor service levels for users.

Progress towards universal access for water and sanitation in rural areas of developing countries will only be feasible through a mix of sustainable service delivery approaches and technologies which fit a specific context. Still there are huge challenges in progress towards universal access which come from limited availability and scalability of proven or new technologies.

Introducing a technology in a market or an area requires significant financial resources and engagement of many actors with different agendas, many activities need to be coordinated and accomplished such as market research. The process of introduction and scaling up of WASH technologies in a specific context can be described by an S-shaped curve which passes three key phases (see Figure 1, Olschewski and Casey 2013).



## ACCELERATING SELF SUPPLY

### Technology Applicability Framework (TAF) experiences

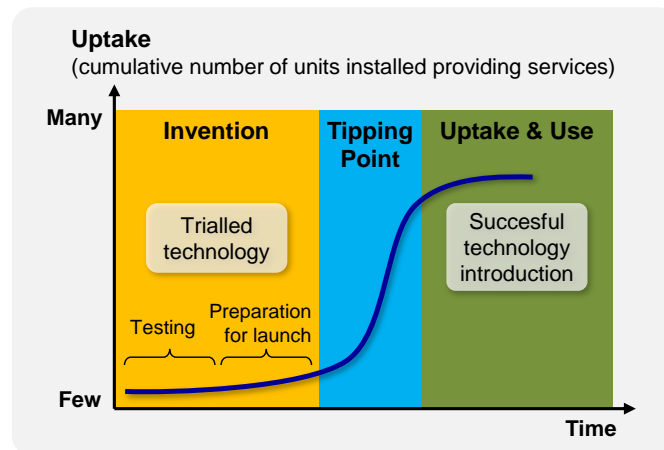

Figure 1: Phases of uptake of technology over time

One particular concern is the fact that in the beginning of the introduction process there will be only costs e.g. for piloting, but little or no revenues. This will lead to a “valley of death” (see figure 2).

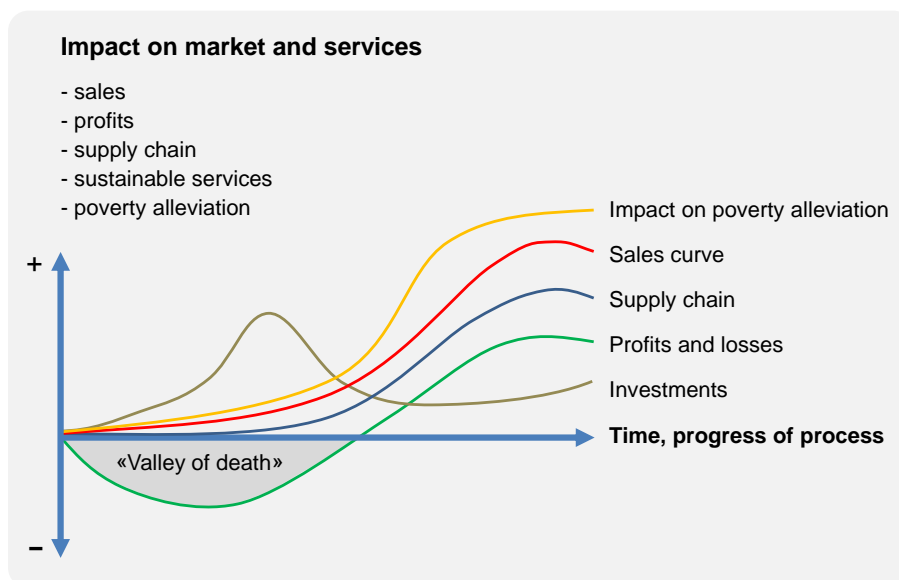

Figure 2: Introduction of technologies and the “Valley of death“

Therefore for any institution interested to introduce a WASH technology it is vital to know as early as possible if a specific WASH technology might be applicable and scalable in a certain context or not and what to do for supporting further scaling up. However so far there was no such tool which provides a simple and efficient assessment of applicability and scalability of a WASH technology in a specific context, which considers the service delivery approach, its scalability and involves users, technology developers, technology promoters, government and academia in assessments (Schweitzer et al, 2014). To fill this gap the Technology Applicability Framework (TAF) was developed as part of the WASHTech project in 2013 and promoted through knowledge networks and social media, e.g. webinars. The TAF is linked to a generic guidance tool, the Technology Introduction Process (TIP), which is based on the concept of “technology road mapping” (Moehrle et al 2013). Both tools are available and later uploaded in the public domain ([www.washtechnologies.net](http://www.washtechnologies.net)).

Since the end of WASHTech project in December 2013 several organisations have applied the TAF to various WASH technologies in different cultural contexts, most of them without much external support. This paper discusses the performance and uptake of the TAF so far, some findings on applicability and

## ACCELERATING SELF SUPPLY

### Technology Applicability Framework (TAF) experiences

potential for supporting business development for WASH services and gives an outlook on potential developments of the TAF.

#### Context, aims and activities undertaken

The TAF is a participatory decision support tool for assessing applicability and scalability of WASH technologies in specific contexts (Olschewski & Casey 2013). The TAF uses a comprehensive set of 18 indicators to capture the factors describing applicability of a technology, the potential for sustainable services as well as factors needed to be in place for taking the technology and service to scale. The 18 indicators cover six sustainability dimensions and the perspectives of three key actor groups involved in technology introduction (see figure 3).









Perspective / Sustainability Dimension	User / buyer 	Producer / provider 	Regulator investor facilitator 
<b>Social</b> 	(1) Demand for the technology	(2) Need for promotion and market research	(3) Need for behavioural change and social marketing
<b>Economic</b> 	(4) Affordability	(5) Profitability	(6) Supportive Financial Mechanisms
<b>Environmental</b> 	(7) Potential for benefits or negative impacts for user	(8) Potential for local production of product or spares	(9) Potential for negative impacts or benefits for natural resources on a larger scale
<b>Legal, institutional, organisational</b> 	(10) Legal structures for management of technology and accountability	(11) Legal regulation and requirements for registration of producers	(12) Alignment with national strategies and validation procedures
<b>Skill and knowledge</b> 	(13) Skill set of user or operator to manage technology including O&M	(14) Level of technical and business skills needed	(15) Sector capacity for validation, introduction of technologies and follow up
<b>Technological</b> 	(16) Reliability of technology and user satisfaction	(17) Viable supply chains for product, spares and services	(18) Support mechanisms for upscaling technology

Figure 3: TAF indicators using 18 indicators in 3 perspectives

Between 2014-2016 feedback on more than 15 TAF applications were received from 10 different institutions:

#### On water related technologies:

Technology	Focus of Service delivery approach	Region	Institution/contact
Handpump water meter	To be defined	Uganda	Appropriate Technology Centre (ATC) Uganda
Household Water treatment	Business	India	Tara India / Antenna Technologies Geneva
India Mark Pump	Community	South Sudan	IRC
Household water filter	Household	Nicaragua	WaterAid Nicaragua
Rope Pump	Household	Nicaragua	WaterAid Nicaragua
Community supply using handpump, diesel engine with piped scheme or solar powered piped scheme	Community	Tanzania	WaterAid Tanzania

## ACCELERATING SELF SUPPLY

### Technology Applicability Framework (TAF) experiences

Planning WASH services <sup>125</sup>	Community	Tanzania	WaterAid Tanzania/Government of Tanzania
BluePump	Community	Kenya	Oxford University UK

#### On sanitation related technologies:

Technology	Focus of Service delivery approach	Region	Institution/contact
Biofil toilet	Business	Ghana	Biofilcom/TREND
Desludging device	Business	Zimbabwe	Welthungerhilfe / IRC
DEWAT System	Community	Afghanistan	GIZ
Pour flush latrine	Community	Nicaragua	WaterAid Nicaragua
VIP latrine	Business	Tanzania	WaterAid Tanzania

#### On technologies outside the WASH sector and service approaches:

Focus	Focus of Service delivery approach	Region	Institution/contact
Reconstruction of housing	Emergency	Philippines	Welthungerhilfe
Self-supply as service delivery approach	Community	Sierra Leone	Technical University of Cologne / Wuppertal Institute
Biogas digester	Community	Colombia	Technical University of Cologne

For most of the case studies some documentation of the result of the evaluation is available and shared through the web resource [www.washtechologies.net](http://www.washtechologies.net). Unfortunately there is only little information available on the process of TAF application or on how results were used afterwards. Each TAF application and results are very context specific, e.g. different technologies and stages of development were considered, there are different levels of capacities in the sector to apply the TAF and not all application are well documented in terms of meta data. Despite all these limitations some findings should be shared which might inform those who consider applying the TAF in future.

### Main results and lessons learnt

#### Conceptual and strategic aspects:

- The TAF is a decision support tool. TAF users should therefore understand well what questions they want to ask and if the TAF is the right tool to answer these questions. However apart from thematic answers one key benefit of the TAF is that as a process it triggers exchange, discussion and learning between everyone involved in introduction, management, financing and use of technology.
- Due to the qualitative methodology it provides a qualitative result, which should be fleshed up with some semi-quantitative data. The results should allow well grounded "YES", "NO" or "YES IF" decisions on how a technology can support sustainable service delivery. The TAF is not designed to allow directly the selection of technologies and it is not supposed to be an evaluation tool for programmes or projects.
- The TAF is designed as a generic tool, therefore it should not be taken and applied “just from the shelf” without any customization. The challenge is that many organisations are pressed for time and have resource constraints meaning they might push hard to reduce upfront preparation. There is the risk that the quality of findings and trust in the methodology will be compromised if adequate efforts are not made to customise the tool up front.
- For each TAF application sufficient upfront preparation and contextualisation through skilled and experienced personnel are needed. In particular it is key to have a strong, experienced facilitator who will lead through the entire process from preparation up to facilitation of the work-

<sup>125</sup> . In Tanzania the TAF is a voluntary planning tool featured in the Project Implementation Manual for the Water and Sanitation Development Programme II. A training of trainers was provided for more than 30 regional water officers of the Ministry including NGO partners.

## ACCELERATING SELF SUPPLY

### Technology Applicability Framework (TAF) experiences

- shop.
- The TAF concept offers a flexible framework which can be further developed to different technologies and purposes such as for monitoring of programmes (Nicaragua) or assessment of various ICT tools. More organisations are interested in developing specific tools based on the TAF methodology, e.g. for promoting ICT (by IRC) or for supporting the scaling up of technologies (GIZ).
  - As the TAF requires a certain level of capacity, skills and facilitation. Sufficient time and appropriate selection of facilitators are needed to get the best out of site visits and workshops. If language skills (English) and capacities within the sector are weak such as in parts of South Sudan, applying the TAF becomes a major challenge and needs particular preparation and support e.g. translation of materials into local languages. However where there are sufficient resources and already a certain level of understanding, the TAF becomes a standard process and can be applied without major external support such as in Nicaragua.
  - The TAF uses a joint workshop for the scoring involving all stakeholders as a catalytic moment in the process. This approach works in many social economic and cultural contexts. However in India due to cultural norms (not all people are allowed to sit in the same meeting. Therefore the workshop had to be split up in a series of workshops which made exchange and learning more challenging. In Nicaragua, when assessing sanitation, participants split up into gender specific groups to discuss sensitive issues separately. In Afghanistan the TAF application was split into three workshops because of unavailability of personal due to the time of year and security concerns.
  - Almost all users of the TAF appreciated the exchange and joint learning which was created through the process, e.g. in Nicaragua where the TAF combined for the first time technology assessment and participation of users, NGOs, service providers and government agencies.
  - One of the key indicators for all assessments is “affordability” (indicator no4). Experiences show that is a challenge to collect valid data to figure out the lifecycle cost components. However in many cases “affordability” is an issue, which is relevant considering the SDG targets.
  - The scoring is based on qualitative scoring questions which should be answered in the workshop. Some workshops managed to apply scores even with no hard facts, other groups struggled and were looking for more “objective” methods. As the indicators are limited to keep the TAF manageable they are somehow aggregated and need qualitative data. Therefore there is a limit on how far a participatory process doing scoring can be designed in a more transparent process. In Tanzania participants struggled to give “red” scores e.g. to indicators at government perspective as this would mean that the own staff would score its own government as “red”. This story shows that apart from “thematic “discussions and exchange the process of going through the steps of the TAF by all participants together triggers joint learning and strengthens accountability which is a very valuable achievement as well.
  - So far there were too few TAF applications in one country to assess the impact of the TAF on the level of innovation and the capacity within the sector of that country.

#### Operational aspects:

- As the TAF is a participatory tool and most of its benefits are generated through the open discussion of issues and on accountability, it is key to have a strong independent facilitator, who can lead through the entire TAF process. This person needs strong facilitation and social mobilisation skills as well as some background in the area of WASH technologies and services delivery. She/he needs good language skills to translate the wording and concept of the TAF into any local languages. The facilitator must also ensure that technology/service users participate in the discussion. In Nicaragua the preparation process went a step further as the TAF questionnaires have been translated in a local language (Misquito) considering local socio-cultural context. The facilitator needs to be an experienced and respected person as she/he has to deal with strong voices that might interfere with the discussion and bring in a hidden agenda. For big group workshops such as for the training of 35 Regional Water Officers in Tanzania on TAF two facilitators were involved.
- Upfront preparation for the TAF, e.g. data collection on the lifecycle cost of the technology

## ACCELERATING SELF SUPPLY

### Technology Applicability Framework (TAF) experiences

and facilitation of the process need time and resources and is a precondition for a meaningful TAF process.

- Rough cost figures for one TAF application can be estimated based on several TAF applications which were conducted in different contexts: Once the team applying the TAF is acquainted with the TAF methodology and context one TAF application takes about 6-8 working days in total including preparation, field trip for data collection and for the workshop with the local team. Out of the 6-8 days at least 2 days are needed for contextualisation of questionnaires and desk research (data reported from Nicaragua and Kenya). Average costs for transport venue, per diem of participants are about US\$ 2,000.

The costs for preparation and facilitation might increase up to US\$3-5,000 if team members are not familiar with the methodology and need more time and support for contextualisation and preparation. If producer or retailer is not present in the region, there might be additional costs to bring them into the region for the workshop. However even under these conditions the costs for applying the TAF are still small compared to much higher opportunity costs if one considers the costs e.g. for one borehole and handpump which are installed in vain of about US\$15,000.

In contexts where the local private sector should fund the TAF application e.g. in Ghana if a private business wants to launch a new product this investment can be a major hurdle. Here donors could come in to support joint learning and innovation.

Potential of TAF for informing design of business development process:

- In the TAF framework scalability of technologies and related services and business aspects are not presented explicitly in one single indicator, but reflected in various indicators. The key indicators for scaling up can be found in the column of “producer/provider”, but also in the two other columns as all actors influence the scaling up process. Based on the experiences so far the most important factors apart from those in 2<sup>nd</sup> column for producer include No 1, 3, 4, 6, 11, 15, 16 and 18.
- Looking at the components of the Business Canvas Model ([www.businessmodelgeneration.com](http://www.businessmodelgeneration.com)), a widely used framework for describing business concepts, the TAF indicators cover all aspects which are used within the Canvas approach. However the TAF is designed for decision making in an early phase of technology introduction and business development (planning and feasibility stage). Therefore for supporting the uptake of technologies in later stages it is necessary to further develop and apply more specific tools.

## Conclusions and Recommendations

The TAF has been applied by various institutions and there plans to further establish it for monitoring and supporting scaling up of services. Users appreciate the TAF to be a robust and flexible tool for assessing applicability and scalability of technologies. Challenges for TAF applications include the need to invest sufficient time and resources in upfront preparation and contextualisation of the tool. It is necessary to use an experienced and independent facilitator and have at least one participant who is well informed about the technology under review. In some countries the TAF has become a monitoring tool for routine appraisal of technologies. Further research could explore the usefulness of the TAF in shaping business models for different technologies. When the TAF is used better efforts must be made to document experiences, particularly in relation to impact sustainability of services at a sector level and on innovation.

## Acknowledgements

*The interest and enthusiasm of all TAF users, who have shared their experiences, ideas and have contributed to the development of the TAF are gratefully acknowledged. Jo Smet (IRC) who led the consortium of partners that developed the TAF.*

## References

## ACCELERATING SELF SUPPLY

### Technology Applicability Framework (TAF) experiences

- Schweitzer, R., Grayson C. and H. Lockwood (May 2014) Mapping of WASH sustainability tools (IA)://www.waterservicesthatlast.org/content/download/3222/30450/version/5/file/Triple-S-WP+10+Mapping+of+WASH+sustainability+tools.pdf
- Moehrle, M., G., Isermann, R. and Phaal, R. (2013) Technology Roadmapping for Strategy and Innovation – Charting the Route to Success; Springer.
- Olschewski A. and Casey, V (2013) Research Report Processes for strengthening the sustainability and scalability of WASH services Development of the Technology Applicability Framework and Guidance for Technology Introduction — Research Report; 2013: <http://washtechnologies.net/en/taf/documentation/details/547>
- Olschewski A. and Casey, V (2015) The Technology Applicability Framework — a participatory tool to validate water, sanitation and hygiene technologies for low-income urban areas; in S. Hostettler et al: Technologies for Development — what is essential? Springer Publisher.
- Web-resource for the TAF and TIP: [www.washtechnologies.net](http://www.washtechnologies.net)

## ACCELERATING SELF SUPPLY

Technology Applicability Framework (TAF) experiences

# Technology Applicability Framework: Cases from Uganda for WASH Technology validation and uptake

Type: Long Paper

**Authors** Paul Kimera, Senior Research Officer, Appropriate Technology Centre for Water & Sanitation (ATC), [kampkim2001@yahoo.co.uk](mailto:kampkim2001@yahoo.co.uk), +256772685053

Kenan Okurut, Coordinator, ATC

Asha Bamutaze, Senior Training & Development Officer, ATC

### Abstract/Summary

This briefing paper reflects on the Technology Applicability Framework which was developed by the WASHTech project in Uganda as a tool to help validate the appropriateness of WASH technologies in specific local contexts. Three years after the end of the project, the tool is playing a crucial role in identifying blockages to sustainability and scalability of WASH technologies in Uganda. Through continued application of the tool, stakeholders are gaining a better understanding of the technology introduction process and learning is documented and shared within the sector. The TAF has provided valuable lessons on the context into which WASH technologies may do well. Particularly, this paper considers lessons learned from its application on the Urine Diversion Dry Toilet (UDDT) and the metered hand pump. Results of using TAF on the UDDT have shaped ecological sanitation research and promotion of the technology country-wide. Through application on the metered hand pump, the TAF reveals how technology innovations may introduce new operation and maintenance management models that promise to deliver more sustainable rural water supply services. The TAF, together with the Technology Introduction Process (TIP) a commitment to improved documentation of learning about WASH technologies, represent an organized technology introduction process and validation procedure available to the WASH sector in Uganda.

### Introduction

The WASHTech project was a 3-year project funded by European Union's Research and Innovation funding programme for 2007 – 2013 (EU-FP7) and implemented by a consortium that included IRC, TREND, NETWAS (U), Cranfield University, Skat Foundation, WaterAid and KNUST. WASHTech was listed among the 13 most remarkable projects out of 85 projects evaluated under the EU-FP7-Environment Programme (European Commission, 2014). The project ran from 2011-2013.

The Technology Applicability Framework (TAF) was one of the outputs of WASHTech. The TAF was developed through action research in Burkina Faso, Ghana and Uganda as a tool to validate new or existing WASH technologies on their appropriateness within a specific context to contribute to water or sanitation service delivery. It held the promise of enabling decision makers to make informed decisions on WASH technologies (Skat, 2013, p.5). The TAF is a participatory tool that brings together the perspectives of diverse sector actors through field data collection and a validation and scoring workshop. This paper particularly looks at how the TAF is being applied in Uganda to contribute to improved water and sanitation service delivery.

During WASHTech, efforts were made to find a host for the TAF in each of the 3 countries. In Uganda the host is the Appropriate Technology Centre for Water & Sanitation (ATC), the research arm of the Ministry of Water & Environment (MWE). The MWE has traditionally been seen as the entry point for those who wish to introduce or promote WASH technologies in the country and they have delegated the role of validating such technologies to the ATC. A researcher from the ATC was involved in testing the TAF and participated in consortium meetings during the WASHTech project.

## ACCELERATING SELF SUPPLY

### Technology Applicability Framework (TAF) experiences

The ATC has relied on the Technology Introduction Process (TIP) to prescribe a procedure for those who wish to have technologies introduced or validated. The TIP, also an output of WASHTech, outlines the steps for introducing a WASH technology including steps to manage uptake and take a technology to scale. With the TIP and the TAF, a technical working committee developed the ‘Guidelines to WASH Technology Introduction in Uganda (GTI)’. The TAF is viewed as an essential tool in understanding a WASH technology and the context in which it may be applicable, but also enabling appreciation for barriers to introduction. Its participatory nature has been key in promoting understanding of the issues amongst the key stakeholders: users, regulators and producers/providers of technologies. It has also promoted understanding of the importance of six sustainability indicators to the success of a technology in a given context. These are institutional/legal, skills & knowhow, technological, environmental, social and economic.

The results obtained during the testing of the TAF have informed decisions on whether and how to scale up specific WASH technologies. Application of the TAF has continued in Uganda since the end of WASHTech, including on Solar Disinfection (SODIS), inclusive toilet facilities and the metered hand pump. The documentation of assessed technologies has improved so that lessons learned can be shared with those who wish to take these technologies to scale. As Uganda grapples with improving water and sanitation coverage the TAF remains highly relevant as a tool to understand the context (geographical, social, and economic) in which promising technologies are introduced. The TAF has influenced the perception of some technologies both positively and negatively and remains an effective tool for evaluation of WASH technologies in a transparent way, as well as for monitoring.

#### Context, aims and activities undertaken

##### Context

In 2011, Uganda’s water sector framework was guided by the National Water Policy (1997) and the Water Statute (1995). These provided for the use of appropriate low cost technologies that offer community participation in decision making, implementation and operation and maintenance. These documents also required that only well-known and tested technologies should be used. However, there was no established procedure for testing and validating such technologies (Kimera & Achiro, 2011). Furthermore, there was no clear technology introduction procedure. Documentation of introduced technologies was seldom done as there was no particular organization responsible for this. Lessons learned from the introduction of technologies were often lost as a result. Even for a technology such as the U2 pump which had gone to scale in the country at that time, most stakeholders were unaware of any tests being done. The WASHTech project, which examined both the technology introduction process and a technology validation tool, has therefore added much value to the sector.

During its development and testing, the TAF was applied to five technologies in Uganda: the Urine Diversion Dry Toilet (UDDT), the ferrocement tank, the solar pump, the rope pump and the U2 pump. The different technologies were assessed on a district basis and the results were considered to be representative for the entire district. In selecting the districts, the research team relied on a Knowledge, Attitudes and Practice (KAP) study done for each of the different technologies. A TAF analysis for each technology was done in two districts; one district representing an area in which the technology was considered to be successful and the other in an area where it was considered unsuccessful. The two contexts were expected to provide an accurate national perspective into the kind of contexts and enabling environments that make a particular technology successful or not and determine what considerations are necessary to take the technology to scale.

The WASHTech project ended in December 2013. Since then the TAF has been taken up by the ATC as a tool for validation of WASH technologies in Uganda. Together with the TAF, a National technical working committee developed the ‘Guidelines to WASH technology Introduction in Uganda’ (GTI). It prescribes a step-by-step process for managing the process of technology introduction and uptake with roles of the actors clearly spelt out for each stage of the process. The ATC uses both the GTI and the



## ACCELERATING SELF SUPPLY

### Technology Applicability Framework (TAF) experiences

TAF to aid technology introduction and validation. The GTI and TAF have been used to introduce: inclusive household toilets, inclusive U2 hand pumps, metered hand pumps, and an indicator for solar disinfection of water. Typically whenever the TAF and GTI has been applied in Uganda, the research team has comprised the TAF host (ATC), a District Water Officer, a private sector actor and NGOs that may be involved in technology promotion.

#### Aims

The overall aims of the activities undertaken both during the WASHTech project and afterwards are espoused within the GTI and the TAF. Specifically, they are to:

- Stimulate discussion about a WASH technology
- Assess the potential of a particular WASH technology in a specific geographical and socio-economic context
- Assess the readiness of the sector to scale up a technology
- Support monitoring and evaluation systems for the technology introduction
- Document and formalize technology introduction procedures and processes
- Guide the sector on the technology introduction procedures

#### Activities

##### *TAF Assessment of the Urine Diversion Dry Toilet*

The evaluation on the UDDT was done in July 2012 in Pader, Agago and Kabale districts of Uganda. Kabale is located in Western Uganda while the other two are in Northern Uganda. It was thought that the two areas would provide a rich mix of experiences, particularly because the Northern districts were in a process of post conflict recovery and Kabale was believed to be a beacon of success of the technology (NETWAS & WATERAID, 2013). The cost of the assessment for the two different geographical areas was a combined total of 24, 956,000/- (USD 7,340) The ecological sanitation approach was seen as an approach that could extend sanitation services at household and institutional levels. A number of demonstration facilities were built at health centres, district and sub county offices to promote knowledge of the ecological sanitation approach and stimulate demand for the technology.

*Table 1: Cost of carrying out assessments using the TAF on the UDDT in two regions*

No.	Description	Cost (USD)
1.	Transport costs	2,160
2.	Stationery and Printing	100
3.	Refreshments & meals for participants	440
4.	Allowances for researchers/ participants	4,640
	<b>Total</b>	<b>7,340</b>

The design of the program provided for smaller study teams to collect user data and a larger workshop team to carry out assessment based on information gathered that took into account user, regulator and producer perspectives. Two study teams were dispersed to the two study areas of Kabale and Pader/Agago. Both teams had Team Leaders from the respective Technical Support Units (TSUs) of MWE, local contractors involved in construction of the UDDT, NGOs, a number of district officials responsible for water & sanitation, education and health sectors. In Pajule and Agago the sites visited were located at a health centre, sub county headquarters, schools, a town council, a market and a primary school. In Kabale, the sites were located at primary schools, a health centre and at individual households.

The field study took into account condition of the facilities, their usage, how well users understood the proper use of the UDDT, as well as perceptions and challenges they had. Focus group discussions were used for community toilets to obtain the perspective of the users, while key informant interviews were used to capture the perspectives of the regulators (DLG, MWE) and providers (local contractors, NGOs). All these contributed to the answers sought by the ‘TAF Sanitation Assessment’ tool.

## ACCELERATING SELF SUPPLY

### Technology Applicability Framework (TAF) experiences

#### *TAF Assessment of the Metered Hand Pump*

The assessment of the metered hand pump was taken up by the ATC after the WASHTech project. The assessment was done in October 2015 at a cost of 11,000,000/- (USD 3,000). The costs shared equally between the NGO Water for People and the ATC.

The addition of the water meter to the U2 hand pump was an innovation introduced by Water for People and the ATC. The addition of the water meter makes it more convenient to operate the pump in a business model with easy monitoring by a private operator (ATC, 2015, p.1). The U2 model is the most widely used water lifting technology in Uganda. It is one of only 2 standardized hand pumps in Uganda (Kimera & Achiro, 2010). The metered hand pump was developed to provide a business platform for management of rural water resources, a move away from the model of relying on water user committees (Keesiga and Kimera, 2014), a management model which has contributed to a low level of functionality for hand pumps (Nimanya et al, 2011). It was hoped that the metered hand pump would transform the management of hand pumps into a viable business model and reduce break-down times of boreholes.

There are now 30 boreholes fitted with the metered hand pump in Kamwenge, a district in Western Uganda, serving an estimated 9000 people. There are another 10 such boreholes in Kyegegwa district. The TAF assessment focused in Kamwenge. It sought to determine if the metered hand pump meets user’s needs, is likely to be sustainable and scalable, and to capture valuable learning and experiences with regard to the technology.

Researchers were drawn from international and local NGOs, the national government, local government, hand pump mechanics and users. The 3-day exercise included visits to three sites where the metered hand pump was installed, sharing of findings by the different study teams and then scoring the technology in a workshop attended by all the researchers and other stakeholders.

The scoring was done using six sustainability dimensions (social, economic, environmental, institutional and legal, skills and knowhow, technical) and three stakeholder perspectives (user/buyer, producer/provider and regulator/investor/facilitator). During the scoring exercise, participants tried to reach consensus on a given score for each category by justifying reasons for each score. Whenever consensus was not reached, a vote was taken. Figure 1 shows a graphical profile of the results.

#### **Main results and lessons learnt**

##### **The UDDT**

From a user perspective, the UDDT was considered unaffordable. Unsurprisingly the UDDT was not adopted at a household level in Pader and Agago. The UDDT was adopted, to some extent, in Kabale, utilizing locally available materials such as logs, mud and grass thatch. The logs were generally used for the slab, while the grass thatch was for the roof. The lack of funds for operation and maintenance in all institutions meant that toilets were poorly maintained. Institutions, such as sub county and town council offices, were unable to ensure that ash, a necessary input for proper use of the UDDT, was available. As a result, the institutional facilitates where beset by many challenges including misuse, and simultaneous use of chambers. Schools had a better record with regard to the availability of ash as pupils were encouraged to bring ashes from home. Some facilities especially those used as demonstrations at district, town council and sub county offices were abandoned. Overall, community toilets in Kabale performed better than those in Agago/Pader. There was a clear information gap in Pader/Agago with regard to the proper use of the UDDT technology. Researches attributed this to the war situation where internally displaced peoples returned to find a toilet infrastructure they knew little or nothing about. Generally, UDDT users were unable to manage the technology appropriately based on the current level of skills and capacity. In Pader and Agago, urine from the UDDT was not used.

The level of supportive structures for this technology and funding for further innovations and development to enable successful scaling up were wanting.

## ACCELERATING SELF SUPPLY

### Technology Applicability Framework (TAF) experiences

The TAF evaluation of the UDDT revealed that providers of the technology were not promoting the UDDT nor sensitization on its proper use. Producers/providers of the technology lacked effective mechanisms to carry out targeted market research and much needed follow up. They were also in need of marketing skills.

The lack of demand for the compost from the UDDT, even where the toilets were functioning well, was a barrier because people generally had no intention to use the compost. On a positive note, the TAF evaluation has shaped the national sanitation research agenda to focus on more options for reuse of human waste including manufacture of briquettes for cooking from faecal sludge and composting human waste using worms. In response to the high cost of the UDDT, the fossa alterna (alternating pits composting toilet) has been promoted.

From the observations above, prospects for scalability in the Northern districts of Pader and Agago were low. Prospects were better for Kabale due to difficulty in excavations for traditional or VIP toilets but further sensitization was still necessary.

#### The Metered Hand pump

TAF analysis result in a “traffic light” profile, seen in Figure 1 below. Green represents positive impact, yellow is neutral/potential impact, red represents negative or hindering characteristics, and black is an unclear impact that needs to be clarified (Skat, 2013).

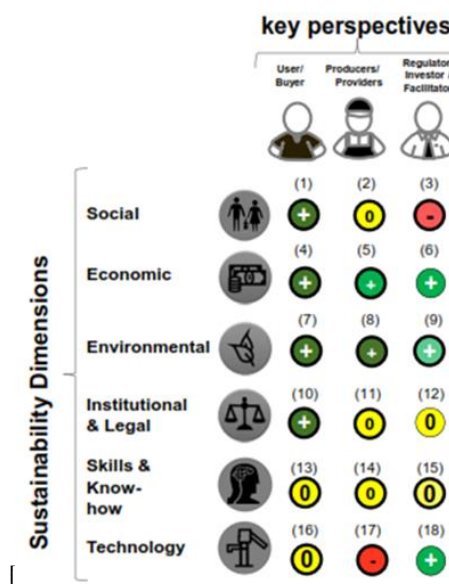

Figure 1 – Graphical Profile of TAF Results for metered hand pump

Source: ATC/Water for People

In the case of the Metered Hand Pump, the profile shows that communities expressed a high demand for the services provided by the technology. They understood that although they had to pay at the point of collection for each jerry can, they were assured of a more reliable service and were thus willing to pay.

#### Social

Social indicator 1 which examines demand was scored positive because users were willing to pay for a reliable service. It was also considered a more equitable system compared to flat monthly household fees that did not take into account the number of users in a household or the volume of water consumed. Social indicator 2 was scored neutral because although there is a team of extension workers in place to do follow ups and the private operators have received some training on marketing, they are yet applying those marketing skills. Social indicator 3 was scored negative because there is a need for behaviour change

## ACCELERATING SELF SUPPLY

### Technology Applicability Framework (TAF) experiences

at the national and local level and it may require policy changes to scale up this model as a viable alternative to water user committees which are provided for nationally.

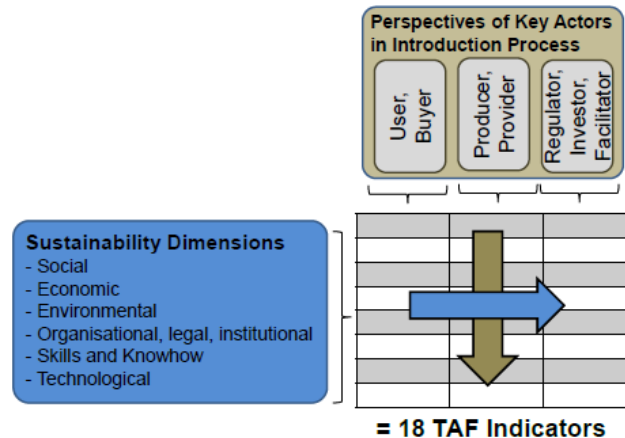

Figure 2: Combining 3 perspectives on 6 dimensions results in 18 dimensions

Source: TAF Manual, 2012

#### *Economic*

Although users were engaged in determining the tariffs, some still find them unaffordable and instead opt for unprotected sources. A small proportion of boreholes have insufficient demand to meet the costs for the caretaker. Economic indicator 4 was scored positive because, in most cases, user fees users cover capital maintenance costs, as well as operational costs thus ensuring sustainability. Economic indicator 5 which addresses whether the private operator can generate sufficient revenues to cover costs was scored positive because with the cluster of 10 boreholes the operators can cover costs and make a profit and the user numbers are growing. Economic indicator 6 was scored positive because there is supportive funding available for operators and hand pump mechanics (HIPMs) to adopt this model. There are also WASH loans available from Post Bank.

#### *Environmental*

The metered hand pump does not present risks to the community or environment. The process used to make the hand pumps also does not pose risks to the environment. Environmental indicators 7 and 8 were scored positive because no negative impacts result from the use of this hand pump. Environmental indicator 9 was scored positive because the abstraction levels possible with this borehole do not constitute negative impacts on the environment. On the contrary, because it is metered, it can monitor abstraction quantities with accuracy.

#### *Institutional and Legal*

The district, through a council meeting minutes, recognized water as a business (WAB) as one of the accepted models for promoting sustainable water coverage. In this model, caretakers are paid a monthly stipend and ensure good care for the borehole surroundings and collect user fees. Legal & institutional indicator 10 was scored positive because the current O&M structure is properly managed and good governance and accountability is practiced. In contrast with the Water User Committee management model, fund collection has greatly improved. There is transparency and records are readily available. The community is aware that the collections contribute to the caretaker's salary, the escrow account and the water boards. Indicator 11 was scored neutral because there are hindering factors at the national level with regard to regulation of the quality of spares of the U2 pump in general. This was however countered by a mechanism at the local level to specify the required standards of materials. Indicator 12 was scored neutral because although the U2 pump is a standardized hand pump for boreholes in Uganda, the water meter it is not. Notably though, the Kamwenge district government is highly supportive of the metered model.

## ACCELERATING SELF SUPPLY

### Technology Applicability Framework (TAF) experiences

#### *Skills and Knowhow*

Users, caretakers and local mechanics are familiar with the metered hand pump. The caretakers are trained and are able to read the meters well and keep records of the daily usage and monies collected. Indicator 13 had a neutral score because the hand pump mechanics lacked the tools and knowhow to handle the U3 modified hand pump which was used at some sources. Indicator 14 assesses the level of business and technical skills. This had a neutral score because the entrepreneurs still need to hone their marketing skills, while the HPMs also had some skills gaps. The sector capacity for validation, scale up and follow up of the metered hand pump considered under indicator 15 and was average at best. This was the case because although technical capacity in country was considered to be adequate, it is not matched by the necessary financial resources to do monitoring and market research needed to scale the technology.

#### *Technological*

Users appreciate the level of service provided by the hand pump. The design has not taken into account accessibility for elderly and disabled people. Hand pump mechanics are available to do repairs and this is manageable for the U2 pump. However, there are challenges with the U3 modified model both with regard to skills and availability of tools. Technology indicator 16 looking at user satisfaction with the performance of the technology was scored neutral due to the high pumping effort required for some pumps. An earlier field test however indicated only an 8% increase in collection time owing to the meter. Pregnant women in particular found it difficult to operate the pump. Technological indicator 17 which examines the viability of the supply chains for spares in the district was considered to have negative hindering characteristics as it was not established. Technological indicator 18 was scored on the basis of support mechanisms for upscaling the technology. This was scored positive because the technology promises sustainability and which is attractive to development partners. However it is still a little known technology outside of the district.

## Conclusions and Recommendations

### *Recommendations for the sustainability and scaling up of the Urine Diversion Dry Toilet in Uganda:*

- There is need to design a UDDT management model at institutional and community levels to ensure misuse is minimised.
- Private sector involvement in purchase, trade and use of compost must be encouraged and stimulated as there is currently very weak demand.
- Further studies on cultural barriers to use of the UDDT and compost should be carried out in different parts of the country.

### *Recommendations for the sustainability and scaling up of the metered hand pump in Uganda:*

- Awareness raising should be done at the National level to promote the metered hand pump as a viable option for increasing the sustainability of hand pumps.
- Some users decry the high tariffs, often reflected by low user numbers for some borehole. Sustained sensitization and marketing is necessary to promote the services provided by this model. The costs for users when boreholes break down if well documented and should enhance willingness to pay
- Behaviour change is required at all levels (including users and national level stakeholders) to face up to the reality that lax models of payment have failed to deliver sustainable WASH services. The metered hand pump business model should be considered for some rural areas, particularly where populations are high

## Conclusions about the TAF

The TAF fills the gap of a tool to monitor or validate specific WASH technologies within a given context. It is highly regarded by the Ministry of Water and Environment and it is actively being applied to validate new technologies in Uganda. The TAF creates ownership about the decisions made with regard to scalability of particular technologies and identifies bottlenecks around WASH technologies.

## ACCELERATING SELF SUPPLY

### Technology Applicability Framework (TAF) experiences

The TAF presents a locally grounded perspective because various stakeholders are involved in the field assessments where they gain a better understanding of grassroots issues and interact with users, producers/providers and regulators, thereby embracing a wider view of the issues. More importantly, through the TAF process stakeholders understand their role in enhancing WASH service delivery as the barriers are identified and the group makes recommendations to enhance sustainability and scalability. The TAF creates a systematic process for documenting WASH technologies that are tested, allowing lessons learned to be shared amongst sector actors and archived for the future.

The Ugandan government, private sector and NGOs have demonstrated the willingness to adopt the GTI and subject their innovations to the TAF analysis. Some have also demonstrated the readiness to fund the costs of the validation, while the costs of the TAF (typically about \$ 3,500 for a single technology in one district) are prohibitive to others.

### Acknowledgements

I acknowledge the important role of Water for People in developing the water meter and selecting a suitable model in which to deploy it, together with their willingness to have it assessed using the TAF. I particularly extend my thanks to Cate Nimanya, Brenda Achiro and Diana Keesiga. I am also grateful for the roles played by WaterAid Uganda and NETWAS in various assessments using the TAF and in efforts to embed the TAF.

Special thanks to Sean Furey of Skat Foundation who kindly accepted to review this paper and provided useful insights to enrich it.

### References

- ATC 2013, *Guidelines to WASH Technology Introduction in Uganda*, p.25
- Cranfield University, Skat, IRC and WaterAid 2011 *Africa wide, water, sanitation and hygiene technology review*, WASHTech
- EUROPEAN COMMISSION 2014, *Ex-post evaluation of FP7 cooperation programme theme “Environment (including Climate Change)”*
- KEESIGA D. and KIMERA P. 2014 *Metered hand-pumps: Privately operated hand pumps as a way to improve sustainability and service delivery*, 37<sup>th</sup> WEDC Conference
- KIMERA, P. and ACHIRO B. 2012, *Baseline survey on Knowledge, Attitudes and Practices*, WASHTech
- NETWAS and WATERAID 2013 *Technology Recommendations for the Rope Pump in Uganda*, WASHTech
- SKAT 2013, *The Technology Applicability Framework Manual*, WASHTech

## ACCELERATING SELF SUPPLY

### Technology Applicability Framework (TAF) experiences

# Using the Technology Applicability Framework (TAF) to improve sustainability of rural WASH supplies in Nicaragua

Type: Short paper

**Authors:** Briemberg, Joshua; WaterAid Nicaragua Country Programme Manager, Nicaragua; [JoshuaBriemberg@wateraidamerica.org](mailto:JoshuaBriemberg@wateraidamerica.org); +505 001-212-683-0430. Denis Le Seve, Miriam; WaterAid UK Consultant, UK; [miriamdenisleseve@wateraid.org](mailto:miriamdenisleseve@wateraid.org); +44(0)7981474639. Casey, Vincent; WaterAid Senior WASH Advisor, UK, [vincentcasey@wateraid.org](mailto:vincentcasey@wateraid.org); +44 (0) 207 793 4932.

### Abstract/ Summary

Developed and trialled by a consortium of partners between 2011 and 2013, the rationale of the Technology Applicability Framework (TAF) stems from an understanding that often water and sanitation technologies introduced are not sustainable in a given context (Olschewski and Casey, 2013). The framework, by providing a participatory process that examines a number of conditions in a given context from three perspectives (i. users/buyers, ii. manufacturers/suppliers and iii. regulators/investors/facilitators), aims to help identify which innovations are good and how to take them to scale sustainably. This paper captures the practical experiences of employing the TAF in WaterAid's Country Programme in Nicaragua. Initially employed to understand more about the Inodoro Ecologico Popular (a pour flush toilet) the TAF has been successfully used to examine three different technologies and is being integrated into broader programme design and monitoring and evaluation processes.

### Introduction

Since 2012, WaterAid's Country Programme in Nicaragua has been applying the TAF, primarily in the remote North Atlantic Autonomous Region. Identified as a robust decision tool that helps determine the match or mismatch of contextual conditions with a certain technology being considered and the key requirements for successful introduction, the framework was initially used to increase understanding of the strengths, weaknesses and potential of the Inodoro Ecologico Popular pour flush toilet. Having since been adopted to assess two other technologies - the rope pump and bio-sand filters - as well as being integrated into programme design, monitoring and evaluation processes, the TAF continues to be an invaluable tool that triggers dialogue between all actors including those at the local and national level.

As the drive to develop innovative and potentially cheaper, more adapted, appropriate and better sustained WASH technologies to serve the poorest is expected to accelerate, so too must the ability to assess the need for a certain technology, the context in which it is to be applied in and the challenges that may be faced. Without such analysis, even so-called 'appropriate' technologies will continue to fail, when the expectations of the users are not met and determining factors to sustain the technology are lacking.

Developed by a consortium of partners, including WaterAid, the International Water and Sanitation Centre (IRC), the Swiss Centre for Appropriate Technology (SKAT), Training, Research and Networking for Development (TREND), the Kwame Nkrumah University of Science and Technology (KNUST), Water and Sanitation for Africa (WSA), the Network for Water and Sanitation (Netwas), the Appropriate Technology Centre Uganda and Cranfield University, the TAF was trialled in Burkina Faso, Ghana and Uganda from 2011 to 2013, examining the suitability of 13 different technologies. Since then, in addition to Nicaragua, it has been used in Tanzania, South Sudan, Afghanistan, Kenya, DRC, India and identified as a useful tool in Colombia.

### Context, aims and activities undertaken

In 2012, WaterAid Nicaragua started to apply the TAF in a remote area in the North-east region of the country. The TAF was chosen for the following reasons:

## ACCELERATING SELF SUPPLY

### Technology Applicability Framework (TAF) experiences

1. It is easy and low cost to apply
2. It is easy to understand and promotes multi-sector engagement
3. It can be adapted and applied to a wide range of technologies.

Initially the aim was to use the framework to have an open discussion about a pour flush toilet option that had been promoted nationally as a sanitation solution in 1997. Following a donor-led survey that drew attention to the weaknesses of the ‘Inodoro Ecologico Popular’, the toilet fell into disfavour and the project was deemed a failure, leading to a high degree of paralysis in the sanitation sector. However, despite these weaknesses, WaterAid Nicaragua had recognised that certain aspects of the technology were positive, especially relating to its social acceptability. The TAF emerged as a useful tool to question where exactly the weaknesses lay and how they could be remedied.

The TAF has since been carried out for other technologies including bio-sand filters and rope pumps, to analyse the approaches or decisions that are being made throughout the implementation process. WaterAid Nicaragua is striving to institutionalise the framework further, into programme design and monitoring and evaluation processes. For example, the TAF is being used in new municipalities to draw together communities, government representatives and service providers to discuss the potential and certain elements (such as water treatment options) and gravity fed water systems. It will be carried out once a year to evaluate progress and scope out the possibility for a municipal wide approach.

The TAF promotes bringing together the perspectives of three groups: (i) users/buyers (ii) manufacturers/suppliers, and (iii) regulators/investors/facilitators. To achieve this, in each case WaterAid holds three separate half day sessions which cumulate in a final session with all participants to discuss the findings and recommendations together.

Generally each group is made up of six to ten people. The users tend to be the largest group, with around ten people. To reflect the groups’ heterogeneity, often male/female or young/old subgroups are created. The group of regulators (which, in Nicaragua has included representatives from the municipal government WASH units, delegates from the Ministry of Health, the Social Investment Fund Programme (FISE) or representatives from the Ministry of Education at the municipal and regional levels) tend to involve six to eight people. WaterAid found that, when different components and materials make up a technology, defining a group of suppliers becomes problematic. In the case of many technologies, such as the pour flush toilet and the bio-sand filters, the number of genuine private-sector suppliers has been limited. Currently local NGOs aiming to create an enabling environment for private sector suppliers to establish themselves fulfil the role of supplier. With independent small businesses manufacturing and supplying rope pumps, it is easier to find private sector suppliers.

The sessions rely on a group of facilitators to guide the discussions. Usually three or four facilitators attend each TAF session having received training on the process in advance. This is in order to facilitate each focus group (i.e. women, men, youth) simultaneously and to ensure the facilitation of the whole process. Each group discusses 18 indicators, including the financial, social, institutional, legal, environmental, technical and capacity conditions in a given context which are crucial for sustainability. Each of these indicators receives a score (based on the technology’s positive, negative or potential impact) which is recorded on a poster. The facilitators are trained to be attentive to other, smaller but important observations that emerge out of the specific questions. In some cases answers to these secondary questions could be critical to the evaluation so they are often scored too.

The cost of the TAF is essentially limited to the focus group sessions so the process is very cost effective. All participation is voluntary so the costs are mainly implicated in the transport to and from the session location or to the field if necessary.

### Main results and lessons learnt



## ACCELERATING SELF SUPPLY

### Technology Applicability Framework (TAF) experiences

Although there are similar frameworks for analysing sustainability, they are often desk-based and rarely present a dynamic mechanism for participative engagement. A key benefit of the TAF therefore, is its capacity to create a space for the voices of different actors to listen, be heard and to recognise roles- both theirs and others. These aspects have come to light in various ways.

The process has highlighted that when environmental and financial issues arise relating to different technologies there is a lack of knowledge on regulatory standards, especially among government delegations. Three examples of where knowledge of the established legal frameworks and standards were lacking include:

1. Health regulations regarding the handling, extraction and final disposal of fecal sludge
2. Drinking water quality parameters in relation to household water treatment technologies, such as biosand filters
3. Well drilling permits and concessions.

Consequently, it has become clear that reviewing and refreshing knowledge on these areas is necessary. The WaterAid team itself has recognised that they need to understand these protocols and legal frameworks, so now ensure that they discuss an innovation or decision with a representative from the national level or review it with the agencies that manage the frameworks. In addition, they have noted the importance of strengthening knowledge in the field of financial aspects, including monitoring the lifecycle costs of a technology- crucial to achieve sustainability.

In such a way, the TAF helps break down barriers between different groups. In Nicaragua, it was realised that suppliers often do not receive feedback on the quality or satisfaction of their products from end-users. At the same time, users often do not have a platform to share their experiences of a product, or willingness to do so, especially when a product has been subsidized. This disconnect is apparent when technologies have been installed by third parties and not the supplier. The rope pumps, for example, were installed by local mechanics after being sold to intermediaries. The supplier would be unaware of any weaknesses in installation but the market for their product would be affected as users, unsatisfied by the end product would be discouraged to purchase the technology themselves again. In this way, the TAF has highlighted that while on the technology side, there are a large number of high quality options, weaknesses are apparent relating to maintenance duties, responsibilities and knowledge of the costs of replacement parts.

With regards to the technology itself, the TAF helps draw attention to aspects of the design or components that would otherwise remain unapparent. Examples include a component of the bio-sand filters that in some cases attracted ants, or fibreglass liners for pit latrines that drove worms to the surface. With the supplier or provider oblivious to these impacts, the TAF became critical to improving the service.

The TAF creates a space for communities to express to the government their demands that go beyond the implementation model. For example, in the case of the pour flush toilets, it became apparent that there were segments of the community that did not have the financial resources to access the technology, despite subsidies being available. During the final discussion session, the community was able to speak directly to government representatives, drawing on rights based frameworks and could bypass the NGO as an intermediary. This was an outcome that could not have been predicted. This also demonstrates the potential when people use concrete issues (e.g. the appraisal of technologies) to confidently bring out concerns around service levels, rights, responsibilities and inequalities.

Lastly, the TAF has resulted in very tangible changes in the approaches of partner organisations. In the case of the bio-sand filters, the partner that was supplying this technology as the only option, realised that there were various financial challenges and consequently chose to expand their product line to include other technologies. As a result of the TAF, this partner also established a successful revolving fund and a no subsidy scheme. They continue to use the framework to address various issues and to increase the awareness of users to use and maintain the products correctly.

## ACCELERATING SELF SUPPLY

### Technology Applicability Framework (TAF) experiences

WaterAid Nicaragua are now working to build the TAF framework into their broader monitoring and evaluation processes. They aim to apply the TAF at the beginning of a project to identify the contextual weaknesses that threaten the sustainability of a certain technology options and service models, then reapply it on a periodic basis to see where progress is being made and if the intervention is working or not. They are seeking ways to further integrate the approach into programme design and have identified two new projects- gravity-fed water systems in a new municipality in Nicaragua and in La Guajira, Colombia - where the framework will be used from the start.

### Conclusions and recommendations

To achieve universal access by 2030, it is vital to approach WASH interventions holistically, understanding the complex financial, social and environmental aspects from a number of different perspectives. Without such analysis, even so-called ‘appropriate’ technologies will continue to fail, when the expectations of the users are not met and determining factors to sustain the technology are lacking. Experiences of the TAF in Nicaragua highlights the benefits of applying an approach that creates a neutral space to generate this information.

This year (2016), WaterAid Nicaragua will be establishing a SMART centre for technologies near Managua. The aim for the centre is to gather small scale, affordable and repairable technologies to be complemented with inputs from the private sector, the government and regulatory bodies. Each stakeholder would be urged to apply the TAF to understand the potential for a technology before implementation in a specific context. This illustrates the growing popularity of the TAF framework as a valuable tool to improve the lifespan of an innovation.

Arising from feedback from the process, one recommendation has been to develop a simple, digital application to create a report on the sessions to quickly demonstrate the results. Ideally, this could be used to create an online platform to capture experiences from all over the world, relating to a number of different technologies so identify wider trends, general weakness or how certain problems have been solved.

### References

Olschewski, A. and Casey, V. (2013). *Technology Applicability Framework and Guidance to Technology Introduction (Research Report)*. SKAT Foundation, Switzerland.

## ACCELERATING SELF SUPPLY

### Entrepreneur professionalisation and capacity development

#### 3.4.4 Entrepreneur professionalisation and capacity development

---

## The SHIPO and Mzuzu drill method. Two low cost and locally produced hand drilling technologies for tube wells to 50 metres deep.

---

Type: Long paper

### Authors:

Henk Holtslag. Free lance advisor low cost technologies

[Henkholtslag49@gmail.com](mailto:Henkholtslag49@gmail.com) 0031555414156

Walter Mgina Advisor SHIPO SMART Centre Tanzania

### Abstract/Summary

To reach the SDG6, some 3.3 million water jobs are needed in developing countries. (IWA 2016) A large part of these jobs are pump mechanics and well drillers. An important tool to reach the SDG6 (safe and affordable water for all), is reducing the cost of tube wells and one way to do that is to scale up manual drilling options. Manual drilling of wells can provide low-cost, but high quality water supplies and organisations like UNICEF and others are now promoting manual drilling at global level. The cost of manual drilling is significantly lower than for machine drilled wells, at 10 to 25% of the cost. (Danert. RWSN. 2015) An example of an innovative and low cost option is the SHIPO drill method which was adapted to the situation in southern Tanzania where groundwater levels range from 10 to 45 meters deep. The SHIPO drill combines sludging, percussion and jetting and with tungsten drill bits it can drill in hard layers like sandstone and laterite. Some 800 tube wells in East Africa have now been drilled with this and similar methods with depths to 45 meters deep. The drill sets are made by a local metal workshop and a complete SHIPO drill toolset for 45 metres deep cost ca 700US\$ (Kaduma. 2016). The cost of a tube well made with this option, including a 4 inch PVC casing, is 500 – 1500 US\$ depending on geology and depth.

Another low cost option is the so called Mzuzu drill. This is a combination of a “Soil punch” and a “Tube bailer”. No tripod, pulley or drill pipes are needed. Some 60 tube wells till 18 metres deep have been made with this method. The cost of a Mzuzu drill tool set is around 80 US\$ and can be made with local materials. The Mzuzu drill is also used to deepen hand dug wells that have dried up. Both the SHIPO drill and Mzuzu drill methods are disseminated by SMART Centres in Tanzania, Malawi, Mozambique and Zambia and are considered SMARTechs.

SMART Centres are WASH training centres and SMART is an abbreviation of Simple, Market-based, Affordable, Repairable Technologies. With large scale capacity building on this and other low cost drilling technologies there is much potential to reach the SDG6.

### Introduction

Hand dug wells are a common water source in rural and peri urban areas and there are probably 3 to 5 million hand dug wells in sub Saharan Africa. The advantages and disadvantages compared to drilled tube wells are described in technical notes made by Enterprise Works (EW) and Practica foundation.(UNICEF 2009). An advantage of hand dug wells is that they are simple to make with local skills, have a low cost and in less permeable aquifers they have a storage capacity because water seeps in during the night. A disadvantage is that in general they less hygienic, cannot go deep into the aquifer (the ground water layer) and often dry up in the dry season. Making hand dug wells can be dangerous in soft soils because of collapsing of the wall. This can be avoided by using cement well rings but in general this is costly. Another option To deepen hand dug wells is using “Underlining”, a technique that uses bricks to make well rings inside the well. A problem with hand digging is the lack of fresh air in wells deeper than 5

## ACCELERATING SELF SUPPLY

### Entrepreneur professionalisation and capacity development

meters. (To solve this problem hand powered well ventilators were developed by the SMART Centres in Tanzania and Malawi.)

The other option to reach ground water layers are Tube wells also called boreholes. In general boreholes for communal water supply are made with drilling machines and cost from 3000US\$ to 15000 US\$ (UNICEF, EW, Practica 2009). However in areas with water levels of 50 meters or less and without hard bedrock layers, tube wells can also be drilled with manual drilling. It has now been proven that, if done well and in similar situations, manual drilled tube wells have the same quality and the same pump capacity as machine drilled wells. The advantage of manual drilled wells is that, for the same depth range, they can be 2 to 5 times cheaper than machine drilled wells. (Practica. 2015)

Options like augering and jetting for sandy soils were successfully introduced by EW in countries like Niger. They were mainly used in areas with shallow (3 to 8 meters) ground water levels and a well cost 150 - 250 US\$ including a Treadle pump. Rotary jetting became very popular in Nigeria where a large part of the water supply of Lagos comes from thousands of wells made with this technology. (Danert, 2015), The Rota-sludge technology was with success introduced in Chad and other countries by the Practica foundation. The EMAS method, a simple jetting technique, was introduced in Bolivia and other countries and tens of thousands of mainly householdwells were drilled by local companies at a cost of 7- 10US\$ per meter, including casing and an EMAS pump. (Buchner). Another and similar technique developed in Bolivia by Water for All international is the Baptist drilling method which combines sludging and percussion and instead of metal drill pipes uses only one heavy drill pipe of metal at the lower end and all other pipes are PVC pipes. (Waller). Both these technologies can drill down to 80 meters or more, can be locally produced and cost 100 to 300US\$ for a complete well of 10 to 30 meter deep including casing and a hand pump like the EMAS pump.

Another innovation is the Rota-sludge, a technology based on the Indian sludge method, developed by Practica in Nicaragua in 1995 and later on introduced in countries like Chad and Tanzania. Different from the Baptist method, the Rota-sludge does not use a valve at the bottom but the drill pipe at the top is closed by hand, which can be a bit muddy for the driller. The options mentioned have scaled up and there are thousands of wells drilled by local private companies. There are also technologies that have not scaled up like the Vonder rig that was introduced some 40 years ago in Zimbabwe and Malawi but is hardly used anymore.

Reasons for not scaling up seem to include that the technology was heavy to use and was not seen by companies as an interesting business.

Besides cost reduction for Communal wells, manual drilled wells also have much potential to increase Self-supply (family wells). A recent study in Zambia and Zimbabwe indicates that Self-supply is essential to reach the remote living families where machine drilled communal wells are too expensive. By improving existing and making new Self-supply wells the cost of reaching 100% coverage can be even less than conventional communal supply and can result in cost savings of 330 million US\$ in Zambia and more than 260 million US\$ in Zimbabwe. (Olschewski 2016)

Besides access to an improved water source, Self-supply wells can help to reduce rural poverty. Studies in Malawi and Tanzania indicate that the effect of Self-supply is increased family incomes of between 50 and 500 US\$ per year (Maltha 2015).

### Context, aims and activities undertaken

In 2003 the Rota-sludge drill method was introduced in Tanzania by the organization SHIPO in Njombe with training from the Practica foundation and funded by the Dutch organization Connect International. In the so called TAZAMO project some 1500 tube wells were drilled with this technology. Since the weight of the 2 inch diameter metal drill pipes becomes quite heavy for wells deeper than 20 meters SHIPO became interested in the Baptist method from Bolivia. This method uses a heavy metal drill pipe of 3 meter length with a valve drill bit at the bottom. The rest of the drill pipes are 4 mm thick walled 1¼” PVC pipes so the total weight is low and even at depths of 40 meters all drill pipes can still be lifted by two people. Another advantage of the PVC pipes is that the percussion impact is not on the joints (sockets) of the drill pipes but on top of the drill bit where it has most effect. The result is less pipe or joint breakage than with metal drill pipes. The Baptist drill method was adapted to the local situation with different drill bits and larger diameters. To drill hard ground layers like laterite, drill bits with tungsten tips

## ACCELERATING SELF SUPPLY

### Entrepreneur professionalisation and capacity development

were made. The SHIPO method is now also combined with jetting using locally available standard engine pumps with a 2 inch outlet. The limitation of a standard pump as compared to a special mud pump is that the pump seal has to be changed every 3 to 5 wells depending the soil type. The advantage however is that these pumps are widely available at a cost of around 150US\$. Experiences in Malawi indicate that the fuel cost to drill 20 meters is 5 to 10 US\$ per well.

#### Master driller in Tanzania

Creating skilled drillers in Tanzania has been a long and winding road. For instance of the 20 people trained by SHIPO in the years 2005 to 2010 only a few became successful in starting a commercial drilling company. One company is the so called Uvino group who now employs 10 to 20 people, including drillers that were trained by SHIPO. There are 2 to 5 drilling teams working in the field to do the drilling and a person trained by SHIPO who now is master driller, does supervision but also the management, making contracts etc.

Because of his experience and skills, this masterdriller now also gives drilling training to others. In cooperation with the SHIPO SMART Centre he has trained drillers from 8 different regions in Tanzania and trained drillers in Malawi, Uganda, Mozambique and Kenya.

#### The SHIPO drill, how it works

With a tripod, a pulley and a rope the drill pipes are pulled up by 2 to 4 people. At the bottom of the lower 30 kg metal drill pipe there is a valve bit which closes when going up and opens when going down. The drill mud lifts sand, clay or stone particles to the surface. The particles stay in settling pits and 'clean' drilling mud is flowing back in the tube well. In hard soils first a 2 inch hole is drilled and later on reamed to the desired hole diameter which can be 3 to 8 inch. When the well is deep enough in the aquifer, a filter screen and gravel pack is installed. The casing is made of standard thick walled (3mm) PVC pipes with diameters of 2 to 6 Inch. After installation of a gravel pack and cleaning of the well, a pump is installed. With this and similar methods some 800 tube wells have been made in Tanzania, Malawi and Mozambique. The knowledge of this method is disseminated via SMART Centres in these countries. The tube wells drilled with this technology can be combined with piston pumps like Afridev, Indian Mark 2 or submersible pumps. In most cases the tube wells are combined with locally produced Rope pumps and used by schools and small communities of maximum 150 users per pump. Because of its low cost, Rope pumps are also purchased by families (Self-supply) for domestic use or irrigation as is proven in Tanzania where some 5000 families paid for a Rope pump.

The cost of 30 metre tube well for Communal supply and made with this option, is 500 – 1500 US\$ depending the casing diameter, geology and depth. If combined with a Rope pump, apron and soak pit, total cost are 700 – 2000 US\$. For Self-supply cost in general are lower because of shallow wells, smaller casings, smaller aprons and the installation of an economy model.



Drilling a tube well of 30 meters deep with the SHIPO drill method  
The SHIPO drill combined with jetting

## ACCELERATING SELF SUPPLY

### Entrepreneur professionalisation and capacity development



One of the drill bits used for SHIPO drilling. It uses shafts of a bicycle as drill teeth and a ‘floating valve’ as foot valve.

New drill bit using tungsten tips. These drill bits can drill hard layers like sand stone and laterite without getting blunt.

#### **Advantages of the SHIPO drill compared to the Rota-sludge drill method**

1. 40 to 60% lighter in weight for the same depth so easier to transport
2. 30 to 50% cheaper; a complete drill set and 4 drill bits cost 500 - 800 US\$ for 30 meter
3. Drilling is a “cleaner” job since the valve is at the bottom
4. Less breakage of pipe threads since the drill pipes are PVC
5. Can be combined with an engine pump so used for jetting
6. The new SHIPO drill sets have tungsten drill bits so can drill in hard layers
7. The light weight, low cost and high efficiency make it attractive for small businesses

#### **Disadvantages of the SHIPO drill compared to the Rota-sludge drill method**

1. Less indication of the material that is pumped up
2. Slower in clay layers. (The Rota sludge can pump up big chunks of clay)
3. Less well known

#### **Mzuzu drill**

Another and very low cost drill technology is the so called Mzuzu drill which was developed by the CCAP SMART Centre in Mzuzu (Malawi). It consist of a “Soil punch” and a “Tube bailer”. No tripod, pulley or drill pipes are needed. The soil punch is made of a pipe with slot and a hard drill bit welded to a pipe of 1.5 inch which is partly filled with sand. In this way the weight of the soil punch is some 15 kg and it can crush hard layers like sandstone and bring up small boulders up to 6 cm. With extensions the Soil punch can make holes to 7 meters deep with diameters of 2 to 8 inch. Than an open PVC pipe with a filter screen (the casing) is placed in the well and is lowered by bailing (pumping) inside the pipe with the Tube bailer, a pipe of 2 to 3 inch with a bottom valve. Instead of a rope the Tube bailer uses a Poly tube. In this way it can be forced up and down and fills up with clay, sand or small gravel. Each time the casing lowers 1 meter a new casing pipe of 1 meter is added. A weight can be connected to the casing to force it downwards. When the casing with filter screen (2 to 6 meters) is in the aquifer, a pump and apron can be installed.

## ACCELERATING SELF SUPPLY

### Entrepreneur professionalisation and capacity development



Making a Tube well with the Mzuzu drill Method, The first 3 to 7 meters is made with a Soil punch  
The Soil punch can be emptied by hammering the 2 inch pipe.



Making a Tube well with the Mzuzu drill. After a first hole with the Soil punch the casing is placed and lowered by using a Tube bailer which pumps out sand inside the casing.  
In this case in Maputo the 6 meters deep Tube was made in 1 day and a Rope pump is installed on a prefabricated slab

Some 60 tube wells have been made with the Mzuzu drill in Mozambique, Tanzania and Malawi with depths till 18 metres deep. The cost of a complete Mzuzu drill set is 60-100 US\$ and can be made with local materials. Both technologies are promoted by the SMART Centres.

#### **Well deepening**

Besides making new wells, the Mzuzu drill can also be used for deepening existing hand dug wells. If a well dries up and there is the danger of collapsing of the wall when it is made deeper than the Mzuzu drill can be used in the following way. A PVC pipe with a filter screen is placed on the bottom of the well and inside the pipe sand is taken out with the Tube bailer. This can be done either from the top of the well or inside the well. Deepening wells with a Tube bailer is safer, faster and often cheaper than placing concrete well rings under in a well.

#### **Main results /lessons learned**

1. With the SHIPO drill type of drilling some 800 tube wells (depths 20 - 48 m) have been drilled in Tanzania Malawi and Mozambique.
2. The cost of a SHIPO drill set to 30 meters has reduced to ca 700 US\$ in Tanzania
3. The cost of tube wells in areas like in Njombe has reduced from 4000US\$ to ca 1500 US\$ by shifting from machine drilled boreholes to SHIPO drilled boreholes.
4. With the Mzuzu drill some 60 wells were made ranging from 6 to 18 meters deep

## ACCELERATING SELF SUPPLY

### Entrepreneur professionalisation and capacity development

5. The cost of a Mzuzu drill set is 60 – 100 US\$
6. The cost of tube wells drilled with the Mzuzu drill are 100 to 500 US\$ depending on cost of transport, depth type of casing.
7. There is much misunderstanding about manual drilling and new options are hardly known by Governments, NGOs or local entrepreneurs in Africa.
8. If well done and in similar geological conditions, the quality (Pump capacity, water quality etc.) of manual drilled wells is similar to machine drilled wells.
9. Good drillers are not necessarily good businessmen.
10. Simpler drilling technology and cheap drillssets increase the interest to make it a business.
11. Even for a low cost 700US\$ drill set often a loan is needed.
12. The SHIPO drill with jetting goes 20 to 50% faster than without jetting.
13. The cost of an engine pump is earned back with 3 to 5 drillings because of less cost for labor. Another advantage of Jetting is that the drill company looks “more professional”.
14. Although manual drilling seems simple, a hard lesson learned is. ‘Simple is not easy’ It takes a long time and good follow up training before local well diggers understand the underground, the hydrogeology which is essential to make a good quality tube well.
15. In general it takes 20 wells with good quality before a driller can be considered as a qualified driller.

### Conclusions

1. New manual drilling technologies can reduce average cost of tube wells by 50% or more
2. A challenge now is massive capacity building and dissemination of this knowledge.
3. Because of the lower cost of wells for Communal water supply, more wells can be drilled with the same budget which should be interesting for Governments and NGOs
4. Manual well drilling has tremendous potential to reach “the last mile” (SDG6), the yet unserved, and make wells where machine drilled wells are too expensive.
5. More local drilling companies results in increased local employment including youth.
6. Because of the income generated by drilling wells there is a “profit based sustainability”, because drillers will go on after training and projects stop.
7. The simple drilling options like the Mzuzu method can be a first step for a driller to start drilling shallow wells and wells for Self-supply. Lateron he can learn more, invest more and drill deeper wells for communal supply.
8. The new drilling options make tube wells affordable for (some) families, (Self-supply)
9. Scaling up Self-supply, has positive impact on food production and reduction of rural poverty. (Mekonta. 2015, Maltha. 2015, Holtslag, 2015)

### Recommendations

10. NGOs and others interested in reaching the SDG6 should invest in large scale capacity building, installing examples in real situations, and create critical mass in each district.
11. Those interested in reaching SDG6 should invest in WASH Training centres like WET Centres (CAWST), SMART Centres ( MetaMeta) or others.
12. The WASH Training centres should include their knowledge in national vocational training
13. Compare different drilling options in similar geological situation to see which option is the most cost-effective and has the potential as a business for the local private sector
14. More funds are needed for R&D to further improve low cost drilling technologies. Each dollar less in the cost of a drill set, each detail that results in simplifying the technology increases the market for these technologies.
15. Explore the possibility for manual drilling by making ‘drillability’ maps for each country

### References

- Buchner, W.* EMAS drilling. Personal discussions. See website EMAS  
<http://www.emas-international.de/> <https://www.youtube.com/watch?v=duv6CVWNNLs>
- Danert, K, Adekile, D., Canuto J.* 2015. Manually Drilled Boreholes  
Providing water in Nigeria’s Megacity of Lagos and beyond Drilling sector in Nigeria.  
Consultancy Report



## ACCELERATING SELF SUPPLY

### Entrepreneur professionalisation and capacity development

*Danert, K.* RWSN. Manual drilling compendium 2015.

<http://www.rural-water-supply.net/en/resources/details/653>

*Holtslag, H, Mc Gill, J.* (2015). Improving self-supply water sources as a key to reach the water related SDG. 38th WEDC International Conference, Loughborough University.

IWA 2016. Stockholm Water Week 2016. Sessions Water and job opportunities seminar. Seminar Report S. Traubel.

*Kaduma, L.* (2016) Personal communication. Meeting of 5 SMART Centres and field trip in Tanzania in May 2016

*Mekonta, L, Butterworth, J, Holtslag, H* (2015). Great expectations: self-supply as a formal service delivery model for rural water in Ethiopia. 38th WEDC International Conference, Loughborough University.

*Naugle J.* WEDC 2009 Sustainable Transfer of Manual Well Drilling Technology

UNICEF, *EW, Practica*, Technical note 3 Manual drilling 2009

*Olschewski, A.* 2016. Review of Self-supply and its support services in African countries

*Maltha, A.* 2015. Assessment of SHIPO Tanzania

<http://www.smartcentretanzania.com/wp-content/uploads/2016/03>

*Waller, T* Personal communication. [https://www.youtube.com/watch?v=eMY11DdE\\_MI](https://www.youtube.com/watch?v=eMY11DdE_MI)

See website Water for All <http://www.waterforallinternational.org/>

Information; [www.smartcentregroup.com](http://www.smartcentregroup.com), [www.smartcentretanzania.com](http://www.smartcentretanzania.com),

[www.smartcentremalawi.com](http://www.smartcentremalawi.com), [www.smartcentrezambia.com](http://www.smartcentrezambia.com) .

## ACCELERATING SELF SUPPLY

Entrepreneur professionalisation and capacity development

# The SMART Centre Approach: training the private sector and scaling-up Self-supply via through a sustainable business model.

**Type:** Short Paper

**Authors:**

Morten van Donk. Tanzania. Annemarieke Maltha. The Netherlands.

Morten.shipo@gmail.com. +255 768019413

### Abstract/Summary

The SDG 6 promises water and sanitation for all but how to reach ‘the last mile’, the small remote rural communities? How to increase functionality of water points, how to scale up Self-supply (family water systems) and reach water related goals like reduction of rural poverty and increased food production? One option is the SMART Centre approach which includes the promotion of SMARTechs; Simple, Market-based, Affordable, Repairable Technologies by innovation, knowledge transfer and training of local entrepreneurs. This paper describes possible solutions through the SMART Centre approach.

### Introduction

#### Self-supply and SDG 6

Of the 660 million people without an improved water source, 80% live in rural areas where piped systems or machine-drilled boreholes often are not possible or too expensive.

Many of the yet unserved households collect water from hand dug wells, often made by (groups of) families at their own expense. This is called Self-supply. Open wells can become improved water sources by low cost technologies such as installing a well cover and an EMAS-, Rope- or other hand pump. To ensure that the well has water all year round a 10 US\$ recharge system can be installed, and to make water safe to drink, a 20 US\$ water filter can be used. The government of Ethiopia promotes Self-supply with Rope pumps to reach 10 million rural families, seeing a number of advantages, such as less maintenance problems and families taking care of their own pump. (Holtslag, 2015, Mekonta, 2015). Self-supply can also increase family incomes by 100 to 500 US\$/year (Maltha, 2015, Roosendahl, 2015) and contributes to food security.

#### The SMART Centre approach

One way to reach people with Self-supply is to use the SMART Centre approach. A SMART Centre is a knowledge and innovation centre that demonstrates and trains (entrepreneurs, technicians and other trainers) in the production of conventional and new rural technologies. Currently, there are centres in Tanzania, Malawi, Mozambique and Zambia and starting-up in Ethiopia, Kenya and Nicaragua. The Centres are all part of local NGOs or education institutes, and at the same time member of the SMART Centre Group to share knowledge and coordinate fund raising to scale up. The group is coordinated by the Dutch Social Enterprise MetaMeta and partly supported by Aqua for All and the Skat Foundation.

Focus is on the following topics:

#### *1 Innovation*

Introduction of new technologies (SMARTechs) that can be produced locally. Examples of SMARTechs are Rope pumps, EMAS pumps, manually drilled Tube wells, Wire cement rainwater harvesting tanks,



## ACCELERATING SELF SUPPLY

### Entrepreneur professionalisation and capacity development

By means of the business model Canvas, the ‘business’ of the SHIPO SMART Centre could be visualised: who are the customers, what is their value proposition and in which way are they reached (Maltha A., 2015; PPPLab Food & Water, 2016)?

The following customer segments were identified:

1. Local entrepreneurs and technicians.
2. NGOs or government, buying training for entrepreneurs and technicians.
3. NGOs, impact investors and others who want to assist in reaching SDG6 and related SDGs such as poverty reduction, food security and job creation.
4. National vocational training institutes

In Tanzania and Malawi the SMART Centre revenue comes from:

1. **Selling training:** Although entrepreneurs increasingly pay for a part of the training, the main financiers of training are NGOs
2. **Contracting:** Implementing rural water points and subcontracting welders to make the pumps and drillers to make the wells. In this way the Centre generates income and can ‘guarantee’ the quality by guiding the companies. Now many pumps are also sold by the companies without the intervention of the Centre (spin-off).

Some of the encouraging results that have been achieved to date include:

1. Introduction of 15 new and cost reducing water technologies (SMARTechs)
2. Over 35 new local companies trained and functioning
3. Over 10,000 Rope pumps produced by these companies
4. Proven market based concept to scale up water access
5. In Tanzania the National vocational training institute VETA, now includes Rope pumps in the curriculum; a major step forward and an official acceptance of the Rope pump.
6. NGOs and government in general positive which resulted in new training.

A SWOT analysis has been carried out to identify the strengths and challenges for the SMART Centre Tanzania in order to learn and to improve processes:

Strengths	Challenges
<ul style="list-style-type: none"> <li>• In-house training capacity, quality manuals and training material of (new) water technologies</li> <li>• Capacity for facilitating Wow visits (Visitors say “wow” seeing the SMARTechs)</li> <li>• Proven market based concept to scale up water access</li> <li>• Demonstration field with new options</li> <li>• Trained technicians now are trainers themselves</li> <li>• Certification in progress to guarantee quality</li> <li>• Support to loans program for companies and users</li> <li>• Follow up support to entrepreneurs</li> <li>• International donor support</li> <li>• Support from specialist with over 25 years of field experience</li> </ul>	<ul style="list-style-type: none"> <li>• Financial dependence on Customer Segment 4 (vocational training centres)</li> <li>• More training skills on business and marketing needed</li> <li>• More skills, insight needed how to scale up the market for SMARTechs</li> <li>• Monitoring insufficient, e.g. mapping, functionality of water points</li> <li>• Network and dialogue with policy makers needs improvement</li> <li>• Small teams, frequent changes in management and trainers limit the building up of experience.</li> </ul>

### Lessons

## ACCELERATING SELF SUPPLY

### Entrepreneur professionalisation and capacity development

There are satisfied customers due to strong value propositions, a proven concept and good customer relationships. The number of customers, however, is relatively small and new customers (entrepreneurs and NGOs) are needed to increase income and scale up.

While the revenue model of training entrepreneurs is sustainable, the revenue model of the SMART Centres is still dependent on donors and impact investors at this stage.

The SMART Centre approach needs more promotion among donors, impact investors and government.

If the SMART Centre wants to decrease its dependency on external funding, focus needs to shift to Customer Segments 1 and 2.

It may also be argued that the current model will create suppliers of SMARTechs who increasingly become able and willing to pay for training services.

### Conclusions

- It has been shown that scaling up the use of SMARTechs and services is possible via the market-based approach and that it decreases the cost of rural water supply.
- Guarantee for sustainability: by anchoring the Centre to a local institute and building the capacity of private sector, embedded in local structures, the dissemination of SMARTechs continues even after intervention of the Centre
- The SMART Centres have successfully introduced a range of SMARTechs in 5 countries and can expand to many more countries via the SMART Centre Group.
- Similar initiatives have shown interest in cooperation and there is strong scope for creating synergy. Cooperation would result in efficient use of scarce global funding resources.
- External funding from international customer segments plays an important role in the first stages of scaling up because training of entrepreneurs is needed to establish a functional supply chain and a critical mass of users. After a critical mass has been reached, entrepreneurs can work independently to grow their business.

### Recommendations

1. Create a solid basis for further scale up: follow up on all trained entrepreneurs and identified imitators, to assess the current size of their business in SMARTechs and to support them with technical and business skills.
2. Certify good quality entrepreneurs preferably together with a government body.
3. Explore the market for SMARTechs in the country of operation and in new countries and train new entrepreneurs by approaching WASH NGOs in those areas
4. Expand social marketing and realization of a critical mass.
5. Improve monitoring. Check installed SMARTechs on functionality, water quality, social and economic impact. A good mapping system is a good tool to attract larger donors active in WASH.
6. Undertake active advocacy and involve governments, WASH umbrella organisations and more policy-related NGOs to get more official support for SMART Centre approach.
7. Set a clear strategy and targets about the approach of each Customer Segment.
8. Continuously discuss the dependency on and availability of donated funds and slowly adjust the business model towards less dependency on donated funds. Explore additional income generating streams such as bulk acquisition of SMARTechs

### References

- A. Maltha. 2015, Study Tanzania  
<http://www.smartcentretanzania.com/index.php/category/highlights/>
- R. Roosendahl, Study impact Rope pumps Malawi
- H. Holtslag, J. M. G. (2015). Improving self-supply water sources as a key to reach the water related SDG. 38th WEDC International Conference, Loughborough, Loughborough University.
- L. Mekonta, J. A. B. H. H. (2015). Great expectations: self-supply as a formal service delivery model for rural water in Ethiopia. 38th WEDC International Conference, Loughborough, Loughborough University.
- M.P. Lammerink, et al. (1995). EVALUATION REPORT. NICARAGUAN EXPERIENCES WITH ROPE PUMP. Measuring the efficiency, the technological, socio-economic and institutional

## ACCELERATING SELF SUPPLY

### Entrepreneur professionalisation and capacity development

sustainability, the affordability, the acceptance and replicability of a specific groundwater lifting technology. The Hague, IRC International Water and Sanitation Centre.

PPPLab Food & Water (2016). [Interactive User Guide for the PPPCanvas](http://www.ppplab.org/wordpress/wp-content/uploads/2016/03/PPPLab-Explorations-02-2.pdf). Presented by Aqua for All and at <http://www.ppplab.org/wordpress/wp-content/uploads/2016/03/PPPLab-Explorations-02-2.pdf> and <http://www.ppplab.org/the-pppcanvas/>

## ACCELERATING SELF SUPPLY

Entrepreneur professionalisation and capacity development

# Impact of SMART Centres to accelerate Self-supply in rural water services. An example from Tanzania

Type: Short Paper

**Authors** Annemariëke Maltha and Morten van Donk. SMART Centre Group, Netherlands / Tanzania  
[ama2048@icloud.com](mailto:ama2048@icloud.com), +31 618863280

### Abstract/Summary

A market-based approach with affordable products such as Rope pumps and hand-drilled wells can increase access to functional water supply. It is an efficient approach to accelerate Self-supply at lower-income households in peri-urban and rural areas and to provide small communities with a reliable water source. Self-supply may result in increased income.

Requirements for accelerating Self-supply are a developed supply chain and well-trained local entrepreneurs. For a complete national distribution and sales network, new local companies need to be found and trained continuously.

In this study, the best marketing seems to be a bottom-up approach. Good-working examples with a certain critical mass, and clearly showing the socio-economic advantages for the user, seem to be an efficient way to create demand and to realize a shift in the customers' decision making in favour of affordable private service-delivery. To avoid risks, consumers prefer to choose the same technology and supplier as their neighbour.

### Introduction

By the year 2030, Tanzania should achieve universal and equitable access to safe and affordable drinking water for all (SDG 6). One way to reach the yet un-served and to improve rural and peri-urban water supply is to use a market-based approach as promoted by the SHIPO SMART Centre. Focus is to improve livelihoods of low-income groups by the use of innovative, low cost and repairable technologies (the so-called SMARTechs) that are produced and sold by the local private sector. Examples of SMARTechs for water supply are manually drilled wells and Rope pumps, but also affordable and efficient drip irrigation sets and locally produced water filters.

The SMART Centre, as a training and knowledge centre, aims to strengthen the local entrepreneurs in production, maintenance, business management and quality control. Main customers of the entrepreneurs are private households (Self-supply) in semi-urban and rural areas, and NGOs or government (communal use).

Several literature studies show that the per capita investment and maintenance costs of a Rope pump are significantly lower than those of a conventional piston pump such as an Afridev pump or India Mark II (P.A. Harvey and Drouin 2006, Acra 2012, iWASH 2013). In small communities, NGOs or government can install Rope pumps or a similar type of pump, combined with manual drilling, to reduce cost. In general the initial investment costs for communal water supply are for 80 to 100% funded by NGOs or government (A. Olschewski 2015, H. Holtslag 2015, RWSN 2015). Low-maintenance costs and local supply can contribute to increased sustainability of the communal water supply.

The lower costs also allow certain households to purchase an own well and pump. Self-supply can further increase water supply sustainability, and private purchase of a hand pump may result in a substantial increase of the family income, as they are often used for multiple purposes, such as drinking, washing, cooking, animals and irrigation.

## ACCELERATING SELF SUPPLY

### Entrepreneur professionalisation and capacity development

In order to increase sustainable rural water supply, it is therefore important to accelerate scale-up of this approach, both for Self-supply and communal use. This paper describes the results of a study how to accelerate Self-supply by looking at two parts of the supply chain: (1) the business of the local entrepreneur and (2) the motivations, needs and demands of his Self-supply customers.

### Description of the Case Study – Approach or technology

The study was carried out at the SHIPO SMART Centre in Njombe. SHIPO introduced the Rope pump in Tanzania 10 years ago. Information about the business of the local entrepreneur was acquired by open interviews with employees of the SHIPO SMART Centre and twelve trained local entrepreneurs in Njombe, Iringa and Morogoro region, who have a business in manually drilled / hand-dug wells and/or Rope pumps. Needs and demands of the Rope pump user (the direct or indirect customer of the local entrepreneur) were studied by interviewing 71 Rope pump users (65% private use and 35% communal use), in Njombe and villages around Njombe, Songea and Mafinga. From the interviews, an approach to accelerate Self-supply was developed.

### Main results and lessons learnt

#### The business of the local entrepreneur and how to increase Self-supply

The local entrepreneurs interviewed served two types of customers:

- (1) the Self-supply customer, mostly one family or a small group of households in peri-urban and rural areas. 95% of the interviewed households indicated they had fully financed the well and Rope pump themselves, the remaining 5% had used a low interest microcredit fund.
- (2) NGOs and government, who aim to supply communities, health clinics and schools with communal wells and Rope pumps. Important for this second segment is to ensure sustainable access to safe drinking water for as many people as possible. Entrepreneurs indicated that they do not supply communities directly: the financial risk is too high and initiatives from the community to purchase a water point by themselves are low. Supply normally goes via NGOs, who can at the same time fulfil an important role in social marketing and awareness creation.

In the period between 2005 and 2010, Self-supply in Tanzania was mainly a spin-off from communal supply. In this period some 1500 Hand-drilled wells and Rope pumps were funded by DGIS funds, and a supply chain was built up. After 2010, SHIPO SMART Centre and other organizations in Tanzania started to train more local companies and stimulated the private sector to also sell to consumers directly. This resulted in a further increase in sales of private wells and Rope pumps. In total, around 10.000 Rope pumps are now known to be sold in Tanzania (number derived from SHIPO reports and former surveys, and interviews with the entrepreneurs). Currently, the SMART Centre has a list of 33 trained small companies which are active in the production and sales of quality Rope pumps and/or hand-drilled wells in Tanzania. In 2015 only, these 33 companies together produced and sold around 900 Rope pumps of which 600 were for Self-supply. Next to the known entrepreneurs, there are some other companies around which copied the Rope pump technology. These companies could be potential candidates for future training programs to increase quality because giving entrepreneurs a good technical training and support afterwards (certification, monitoring, repeated trainings, etc.) is essential to ensure sustainability and quality of the SMARTechs. A broken pump or dry well is bad publicity and will inhibit further scale up.

As incubators, the SMART Centre and other NGOs give newly trained entrepreneurs the opportunity to start their business by supplying wells and Rope pumps to NGOs for communal supply. More established companies, with a few years experience in producing safe wells and quality Rope pumps, are supposed to run their business more independently. Increase in the number of experienced entrepreneurs is therefore expected to lead to a further scale up of Self-supply in rural and peri-urban water services, when they are indeed able to make a living with the sales of SMARTechs. For that reason, twelve companies were assessed how they perceive their business.



## ACCELERATING SELF SUPPLY

### Entrepreneur professionalisation and capacity development

For most of the interviewees, SMARTechs became a significant part of their business (50-80%) after the training and this resulted in an increase in income and job creation. The entrepreneurs did not seem to face heavy competition, they had their own geographical area or had a good long-lasting relationship with their ‘competitors’.

The supply chain seemed to have developed reasonably well: entrepreneurs indicated that all materials to produce a Rope pump were available in Tanzania. In few cases where the local markets were not yet well developed, entrepreneurs travelled to Dar es Salaam for bulk supplies.

Most local companies not only had Self-supply customers in their own region, but also far outside their region. This may have to do with the way they find their customers, or actually, how the customers find them: by good working examples at neighbours, health clinics and other public places. Self-supply customers did not seem to shop around to find the cheapest supplier, but selected the ones they know. One of the entrepreneurs installed a Rope pump as demonstration model next to his office, which was a good marketing tool. Announcements on the radio, on the contrary, did not seem to be very effective.

The business strategy of most entrepreneurs is to expand the customer base with new products like hand pumps and or manually drilled wells. They want to grow by opening a branch office, changing the workshop location, increasing promotion of the products, investing in more advanced equipment or arranging a loan to be able to purchase more material. In reality, however, not all workshops are growing. Sales of products sometimes stagnate or even decrease. The discrepancy in ideas about growth and reality is caused by several factors: a lack of financial means, insufficient business and marketing skills, not enough insight in the market, no detailed strategic planning and, according to Ugula (Ugula, 2015), attitude: people are responsible for their own business, not SHIPO or somebody else.

#### Motivations, needs and demands of Self-supply customers

Knowing the motivations of the consumer can support the local entrepreneur in scaling up his business more efficiently, thus accelerating Self-supply.

The study showed that Self-supply customers invest in an own well and Rope pump to have a reliable and protected water source and abundant water nearby, which is affordable and easy to maintain. With their own water supply, they do not depend on neighbours, on irregular functioning of a communal hand pump or unreliable piped water. *The Danida pump (Afridev pump, ed.) gives limited water, it is old and needs repair. It is a crisis' (family in Mtili, who chose for a private Rope pump).*

From the interviews on household level, it was seen that most Self-supply families have a higher economic status than the communal water users: they had improved housing, more capital goods and often a job outside agriculture, such as teacher, shopkeeper or factory owner.

Interviewees indicated that Self-supply led in most cases to an increase in income. Due to the reliable and abundant water supply, the water was not only used for domestic use such as cooking, cleaning, drinking and washing, but also for commercial use such as construction, keeping animals, gardening, car wash, selling water. On basis of the interviews it was estimated that investing in an own Rope pump could bring a family an annual additional income between 90 and 1350 USD or even more. This is in accordance with other studies: Haanen and Kaduma showed that the Rope pump resulted in additional income for 89% of the households studied (Rik Haanen and Kaduma 2011). An extensive study in Nicaragua showed that annual income of Rope pumps for Self-supply increased yearly family incomes with US \$225 (J.H. Alberts and Zee 2002). A recent study on Rope pump users in Malawi showed an estimated increase in annual income of 180 USD (Rosendahl 2015).

Market-based Self-supply can lead to increased sustainability and functionality of the water point for two reasons: (1) supply by local companies without the need or interference of NGOs and (2) low maintenance and repair costs. The private water points in this study showed a functionality of 92% (compared to 80% of communal supply), with the remark that 40% of the pumps investigated during the study was installed in the last year.

## ACCELERATING SELF SUPPLY

### Entrepreneur professionalisation and capacity development

Although the Rope pump in the case of Self-supply users was bought for private use, the number of households using one Rope pump varied between 1 and 35 households (5 to 175 people), compared to 6 and 40 households (30 to 200 people) in case of communal supply. Thus, even when one family purchased a Rope pump, many households used it. Most owners provided the water for free to neighbouring families, a minority sold the water for 50 to 200 TShs / 20 l bucket. Reasons to provide the water for free was that (1) it was a favour for the neighbours, (2) a habit in the village to share, or (3) fear for the neighbours.

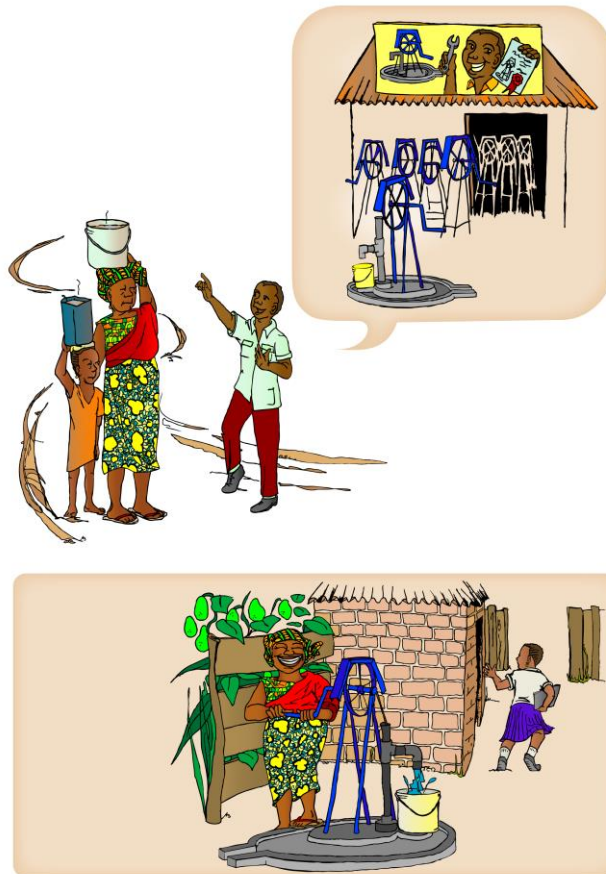

Picture 1. The supply chain of SMARTechs as described in this paper. A local entrepreneur explains the Rope pump, which results in a satisfied customer.

### Conclusions and Recommendations

It has been shown in this study that, when certain conditions are fulfilled, a market-based approach can accelerate Self-supply of rural water services. This may lead to increased access to improved water sources, and ultimately reaching the SDG6 Goals.

There is a sizeable group of customers from middle income and upper low-income groups in both (peri) urban and rural areas, who can afford to purchase the pump for own use. This gives them a.o. convenience and often increase of income. It was seen in the study that Self-supply can increase sustainability of water supply, due to low maintenance costs and ownership.

One of the ways to accelerate Self-supply is to expand the number of entrepreneurs producing and selling low cost water supply

technologies. Continuous training of new entrepreneurs on technical and business skills, including the ones that have copied the technology, should be carried out until a complete national distribution network has been reached.

At the same time, it is important that existing entrepreneurs are supported in sustaining and growing their business. It will help when government and NGOs facilitate them more in several aspects of their business: ensuring that there are enough raw material suppliers, training in all kinds of business aspects, facilitating loans for equipment and material, and providing tools for efficient marketing, taking into account the needs and motivations of the consumer.

The market for Self-supply, thus reaching a larger group of households, can be enhanced by adding other inclusive business models. These are for example innovative financial support solutions, lower cost pump models, partial funding etc. When lower income households can afford a pump themselves, both sustainability and income may increase.

In this study, most effective marketing appeared to be showing good working examples and creating a critical mass, clearly showing the advantage for the users and thus derisking their purchase. The bottom-

## ACCELERATING SELF SUPPLY

### Entrepreneur professionalisation and capacity development

up approach, also described in earlier studies (Hystra 2013, Viswanathan 2015), is therefore one of the more efficient ways to create demand from low income customers. As most local entrepreneurs do not have sufficient capital or knowledge to do extensive (social) marketing, it may be a supporting task for NGOs and government to raise awareness and install low-cost water points for communal use in new areas where the SMART approach is not yet known. After a critical mass has been reached, well-trained entrepreneurs can work independently to create their customer base and sustainably grow their business and thus accelerate Self-supply.

#### References

- A. Olschewski, van Donk, M., Maillo J. (2015). 'Innovative mechanisms for improving self-supply services'. 38th WEDC International Conference, Loughborough, Loughborough University.
- Acra (2012). 'Appropriate Technologies for Rural Water Supply. The Conference on Rope pumps Technology'. SHIPO, Njombe, Acra.
- H. Holtslag, J. McGill (2015). 'Improving self-supply water sources as a key to reach the water related SDG'. 38th WEDC International Conference, Loughborough, Loughborough University.
- Hystra (2013). 'Marketing innovative devices for the base of the pyramid'.
- Alberts, J.H. and v. d. Zee, J.J. (2002). 'A multi sectoral approach to sustainable rural water supply in Nicaragua. Role of the rope handpump'.
- Harvey, P.A. and Drouin, P. (2006). 'The case for the rope-pump in Africa: a comparative Performance Analysis'. *Journal of Water and Health* 04(4): 12.
- Haanen, R. and Kaduma, L. (2011). 'Low Cost Water Solutions (sharing six year experience in private sector and sponsored programme)'. 6th Rural Water Supply Network Forum 2011. Uganda: 4.
- Rosendahl, R. (2015). 'The impact of Rope Pumps on Household Income in Mzuzu, Malawi'. Water Resource Management Group. Wageningen, Wageningen University. BSc.
- RWSN (2015). 'Accelerating self supply (ACCESS)'. Retrieved October 20, 2015, from <http://www.rural-water-supply.net/en/self-supply>.
- Ugula, P. P. (2015). personal communication. Iringa.
- Viswanathan, M. (2015) 'Section I Summary. A Bottom-up Approach to Understanding Subsistence Marketplaces'. Coursera.

## MAPPING AND MONITORING

### Monitoring Systems

## 3.5 MAPPING AND MONITORING

### 3.5.1 Monitoring Systems

---

## WaterAid’s approach to support national and subnational WASH service monitoring processes: lessons learned to inform future work

---

Type: Long Paper

#### Authors

Ellen Greggio, Programme Advisor - Monitoring & Mapping, Programme Support Unit  
WaterAid, UK, EllenGreggio@wateraid.org, +44 (0) 207 793 5070

#### Abstract/Summary

Information relating to the status of water supply services is critical for planning and financing increases in coverage, improvements to existing service levels and post implementation service management. However, as many other authors have previously documented, major challenges still persist in establishing country-led monitoring processes, particularly around data harmonisation, data updating, institutionalisation of monitoring mechanisms and actual use of information collected to inform policy, planning and financing of services. In an effort to guide WaterAid’s future work in support of national WASH service monitoring, a review of previous assistance programmes has been carried out, focusing on 5 countries (Liberia, Malawi, Swaziland, Mali and Kenya). This review has been combined with research on the use of ICT tools for national WASH monitoring and a WaterAid led country survey examining the extent to which WASH monitoring processes have been institutionalised in different countries.

#### Introduction and background

Key decisions in policy-making, planning, budgeting and managing rural water services are reliant on regular information about access, coverage, and service levels. Service users and civil society groups also need this information to hold service providers to account and to advocate for equity in service provision.

For this reason, effective processes for rural water service level data collection, data flow, analysis and information use at national and local level are required. However, data on WASH services is currently not regularly collected and therefore does not consistently inform decisions on service planning, financial allocation and service delivery prioritisation. This is due to a number of reasons, including governments’ resource constraints, fragmented funding, unclear roles and responsibility, emphasis on data collection tools and innovations rather than processes. This couples with limited focus on development of sustainable mechanisms for regular data updating, on use of data to improve service levels and strong donor dominance and the lack of voice of rural dwellers<sup>ii</sup> (Schouten et al, 2015).

To support addressing the above challenges, and strengthening sector monitoring to contribute to sustainable services provision, WaterAid has recently performed a review of past and current organisational approaches and has identified key challenges to inform and shape future work and projects methodology.

#### Country-led monitoring - Current trends

## MAPPING AND MONITORING

### Monitoring Systems

Recognising the need for consistent updated information on water (and on smaller scale on sanitation) services, national and sub-national WASH governments or agencies have recently demonstrated on-going efforts to develop systematic water services monitoring and performance measurement processes and systems (i.e. Uganda, Malawi, Timor Leste, Ethiopia). This includes activities for coordinating different country monitoring processes, developing management information systems - MIS (often including online databases, dashboards and maps), supporting data reconciliation and harmonising indicators (WaterAid, 2010 & WaterAid 2011). In some instances, by progressive testing and adapting different systems methodologies, national rural water monitoring processes have been developed and institutionalised, for example the SIBS system in Timor Leste. Some have evolved into regional monitoring initiatives such as the Rural Water and Sanitation Information System (SIASAR) including Central and South America countries. These systems include regular data collection (although with some gaps and challenges) to inform local and national planning and resource allocations. Several other countries have completed national rural water service inventories (i.e. Liberia), however these have often been one-off donor funded processes which have not evolved into long-term services monitoring systems and processes.

In addition, WASH sector NGOs such as WaterAid, Water for People have initiated regular monitoring initiatives to different extents; however these initiatives and the data collected is often limited to project objectives or is donor-led, and rarely aligns or integrates with broader national or sub-national monitoring processes or contributes to existing services inventories. The presence of multiple stakeholders' monitoring processes leads to fragmented monitoring, duplication of efforts and presence of parallel M&E processes in place. All this goes against the Paris Declaration on Aid Effectiveness, which articulates the need for ownership of development priorities by developing countries themselves, including monitoring processes.

Some efforts to overcome this situation are present:

- the development of country-wide NGO coordination forums accountable to report consolidated information to national government (i.e. UWASNET in Uganda)
- different NGOs sharing project monitoring data through the AKVO SRS platform for examples
- sector stakeholders developing initiatives to support data sharing and aggregation, for example the WPDx platform for harmonisation of indicators and consolidation of available data across several countries (although contributions to this have been limited by data accessibility and governments' willingness to share).

Additional drivers are further influencing sector monitoring activities and processes, in particular:

- Endorsement of human right to water and sanitation by UN and sector recognition of monitoring processes as key building blocks of sustainable services delivery provision and maintenance (Schouten et al, 2015 and Moriarty et al. 2013) also leading to a shift in indicators used for data collection from infrastructure coverage monitoring to inclusion of financial, management, technical information needed to ensure long-term maintenance of services.
- The global water and sanitation Joint Monitoring Programme (JMP), which has been a key instrument in providing comparable information from across the globe on the achievement of the global goals, and has played an important role in influencing the sector's monitoring initiatives. However it is also recognised that the survey-based JMP lacked data disaggregation, and had inconsistent indicator definition across countries which resulted in discrepancies with the national data. The JMP therefore has had limited use in informing country-level decision making and sector planning. The recent definition of the new SDG targets and related monitoring indicators aims at overcoming this limit by increasing data disaggregation analysis and including water quantity, quality, reliability, accessibility and affordability information. JMP has also underlined the need for strengthening countries' national government / regulatory-led sector monitoring processes to inform on quality of services and overall sector performance (JMP, 2015)

## MAPPING AND MONITORING

### Monitoring Systems

- Recent expansion of ICT offering (i.e. survey data collection and analysis tools), coupled with increased presence and investment of private sector in this area, have led to the developments and adoption of ICT-based WASH services monitoring by organisations and governments. Benefits of ICT-based include acceleration of information flow, increased possibility for citizens’ participation in service monitoring (through crowdsourcing), a (relative) data collection cost reduction, improved data consistency and quality and also easier data elaboration, analysis and visualisation. However, too often these initiatives are not fully institutionalised within existing sector monitoring processes, are one-off donor-led initiatives and develop into incongruent databases, accessible only by restricted stakeholders and not widely used by the sector to inform planning, therefore often leading to duplication of efforts.

### Gaps and challenges

Despite the recent development in country-led national and sub-national WASH monitoring, sector performance monitoring is still characterised by:

- Duplication of efforts due to uncoordinated and non-institutionalised monitoring processes by different sector stakeholders (i.e. global monitoring initiatives, services provider monitoring and NGOs donor-led monitoring initiatives)
- Short-term monitoring initiatives (often programme-related) with no associated data updating processes
- Inconsistent and scarce use of data to inform corrective action, planning and policy making at all levels

Furthermore, until now data collection has focused on coverage of services, and major gaps exist in data collection, analysis of data on services quality, reliability, frequency, financing, management and other water service level information, weakening evidence-based decision making needed for services sustainability.

To address the above issues and develop informed decision-making, initiatives that strengthen and coordinate national and sub-national monitoring practices are imperative to achieve ultimately improvement and sustainability of WASH supply services.

### Context, aims and activities undertaken

To further define the potential support role that WaterAid, like other NGOs, can play to institutionalised rural water services monitoring and to develop a suitable approach, a review identifying best practices, gaps and challenges of sector monitoring has been performed, particularly based on previous and current WaterAid experiences.

The review included the following activities:

- Water Point Mapping experience review and identification of lessons learnt.** Review of past experiences and outcomes of water point mapping initiatives, with emphasis on an evaluation of the type of processes and conditions required for mapping initiatives to develop or feed into a broader regular services monitoring process. Learnings have been identified to inform future initiatives.
- Research on role of ICT in support of rural water monitoring (MAVC).** Through a collaborative research with IRCWASH and IDS, the Making All Voices Count research aimed at understanding how ICTs can support rural water points’ breakdowns reporting, and how this information can be used to make governments more accountable and responsive when supplies fail. Using in depth case-studies, the project reviewed existing innovations, investigated their success factors, and examined governance dynamics that affect both reporting and action on rural water service sustainability.

## MAPPING AND MONITORING

### Monitoring Systems

- iii. **WaterAid perspective of state of play regarding sector monitoring in different countries:**  
Survey across WaterAid's country programme to identify current state of country-led sector monitoring, main gaps and challenges to inform future support projects.

### Main results and lessons learnt

- i. **Water Point Mapping experience: lessons learnt and challenges**

Water point and sanitation infrastructure mapping is a process that aims to provide water service providers, policy makers and regulators evidence for decision-making and planning. It includes the combination of geographical positions of water and sanitation infrastructures with information on its technical, management status and demographical data, and its analysis within political administrative areas. The geographical distribution of information on water and sanitation coverage can highlight issues of inequality and functionality levels across a region.

Water point mapping initiatives were introduced in different countries (Tanzania, Ethiopia, Malawi, Mali, Rwanda, Kenya, Nepal and others) to respond to:

- Lack of reliable and updated water services data availability to local governments and other service providers, limiting decision making and planning
- Uncoordinated sector: non-prioritised and uncoordinated planning and resources allocations by multiple stakeholders
- Observed lack of equitable provision
- Poor levels of sustainability of rural water supply

Services mapping initiatives have been entry points for supporting development of processes for service monitoring. Mapping has also been used as an advocacy tool, providing citizens and local governments with information and arguments to demand improved services and, on an operational level, as a tool to provide water service providers, policy makers and regulators with information to improve evidence-based decision making, sustainability and equity of service delivery.

In particular, water point mapping processes, when including more services level indicators, have provided evidence on:

- Service sustainability: identifying water sources or sanitation facilities that are no longer functional, WP with inadequate service or require maintenance, O&M costs
- Equity and inclusion: showing the distribution of improved water sources so that inequalities in services can be identified
- Accessibility: showing the distance communities must travel to find the nearest improved water source or sanitation facility
- Finance and planning needs: identifying areas where investments is needed

WaterAid has worked in several countries with local and national governments and local partners to demonstrate the benefits of water point mapping processes and use of data, starting from Malawi in 2002. WaterAid also developed and provided training on the use of Water Point Mapper, a specific tool to facilitate and simplify data analysis and mapping processes and responding to the observed technical capacity difficulties, particularly at local government. The organisation, through the work with local partners, has played therefore played an important triggering role in introducing and supporting water point mapping processes, which in some occasion have led to the development of broader country-led water services monitoring systems and processes.

Previous mapping initiatives have generated significant evidence for decision making (for NGOs, local and national government) and have also provided important learning on data collection and analysis processes. Most significantly, some mapping initiatives have led to development of country-wide service monitoring processes (i.e. Malawi) and also informed policy changes and resources re-allocation (i.e. Swa-

## MAPPING AND MONITORING

### Monitoring Systems

ziland). Nevertheless, as seen in several services monitoring initiatives, many challenges have been identified throughout, particularly around process institutionalisation, development of data updating mechanism to ensure long-term data representability and ensuring data analysis capacity for information use.

A recent review of 5 different water point mapping case initiatives (Malawi, Swaziland, Liberia, Mali, Kenya\*), which WaterAid had initiated or supported, has highlighted a number of **key common challenges** and important lessons which can inform future monitoring and mapping initiatives, in particular when attempting to develop these into broader and long-term services monitoring processes.

Some key common challenges or limitations encountered by WaterAid when developing and establishing water point mapping initiatives included:

1. **Incomplete decentralisation of service delivery responsibilities and capacity** leading to insufficient resources availability and capacity for decision making at local level including:
  - limited governmental staff human resources with allocated time and responsibility to sustain services monitoring and planning processes and frequent staff turnover
  - limited financial resources allocated to sustain a regularly updated monitoring process at local level
  - limited technical capacity and expertise for data analysis and processing within local government staff)

*In Malawi, decentralisation of water services planning and implementation processes occurred slowly, particularly in the allocation of financial resources. This affected local government capacity to regularly monitor water services and respond to services delivery and maintenance needs. Unclear roles and responsibilities and low resource availability at the local level delayed the uptake of monitoring and mapping processes (i.e. data collection, analysis and use) to inform sector planning. Only with the achievement of institutionalised monitoring process (national led but built on local capacity), clear definition of roles and responsibilities and alignment with sector policies, was a substantial improvement to the availability of data both at district and national level observed, enabling better decision making and service delivery in the WASH sector (EWB, 2014).*

- **Weak sector coordination and unclear roles and responsibilities:** the fragmented and uncoordinated sector with multiple parallel stakeholders acting in service delivery and maintenance often yields non-harmonised and fragmented service monitoring and planning processes, and occasionally duplication of efforts. Unclear roles and responsibilities for services monitoring and data sharing within national, local government and other sector stakeholders reduce the effectiveness and ownership of country-led monitoring processes to inform sector planning.

*In Swaziland, the presence of over 15 implementing partners in the rural water supply and sanitation sector, and the absence of a coordinated monitoring and evaluation process and clear roles and responsibilities for sector monitoring, led to many water supply schemes being constructed without the district staff having the means to influence scheme locations or to monitor their continuous service provision. Political, budget or time pressures strongly influenced service delivery, leading to a lack of equitable provision. Furthermore, lack of collaboration and coordinated planning between implementing partners caused duplication of efforts in service delivery and an observed poor level of sustainability of water supplies.*

- **Weak technical capacity to maintain monitoring systems and processes and use data to inform decision making,** particularly at local level where technical capacity and skills are often limited and require regular capacity building for data collection, analysis, management and use, often lost also due to the high staff turnover observed. In addition, a number of technical limitations for data collection processes have been observed including limited mobile network in the



## MAPPING AND MONITORING

### Monitoring Systems

most remote areas, limiting the automatic transfer of data collected with mobile phones (which need offline systems adaptations).

*In Mali the mapping process was linked with the Localising Millennium Development Goal initiative (LMDG-I) programme aimed at supporting decentralisation processes and focusing on decentralised service delivery. WA initiated water point mapping initiatives at local level to support local capacity for monitoring and data analysis. The small size of the decentralised administrative units, given responsibility for services monitoring, limited the availability of technical capacity and resources, particularly when data analysis involved use of more complex GIS tools.*

*In Liberia, the selection of GIS based data analysis and the lack of capacity of sub-national staff to perform advanced data analysis and use GIS tools determined a loss of engagement in the data analysis process and limited the data use for service planning at local level. The use of Water Point Mapper tool was therefore introduced to facilitate local level data management, analysis and use.*

- **Lack of prioritisation to continuous data use and updating and engagement focused on data collection processes and tools** rather than on development of overall long-term monitoring processes and systems, including data analysis for use to inform policy and planning and regular data updating.

*In Mali the lack of a clear objective and plan for data use at start of the mapping process reduced the impact and overall use of the mapping process generated data to inform local policies and planning.*

*In Kenya data generated from mapping process use was limited and occurred mostly only where strong external technical and coordination support was provided.*

*In Liberia the national inventory was performed with use of mobile phone application, AKVO FLOW and with strong technical and coordination support from external organisations, however with little attention to the long terms sustainability of the monitoring approach, updating mechanisms and use of data for planning.*

From the above past experiences of WaterAid’s supported water point mapping and services monitoring initiatives and the MAVC research outcome, **key lessons** have been identified which can inform future approaches and principles to support rural water point mapping and broader sector monitoring processes:

#### 1. Institutionalised monitoring process

Rural water services monitoring and mapping initiatives should be institutionalised through continuous involvement, engagement and seeking where possible, leadership of government (at national and local level) in coordination with other sector stakeholders responsible for service delivery. Process institutionalisation allows for:

- Build on or contribute to existing information flows for planning (i.e. existing data collection, analysis process etc.) addressing gaps rather than introducing new processes
- Increase engagement, data acceptability and use of the information provided
- Increase long-term sustainability and ownership of the monitoring and mapping process, leading to definition and allocation of clear roles, resources and responsibilities

Through process institutionalisation, policies, clear roles and responsibilities definition for regular data updating mechanisms, data analysis and use could also be developed and defined, with clear financial, human and technical capacity allocation. This should be comprised also when monitoring processes are funded with support from external donors, NGOs or other actors.

*In Malawi, the roll-out of country-wide rural water M&E process (although with some limits) has been achieved through strong national level government and stakeholders’ engagement and buy-in which ensured definition of clear leadership and governance roles. EWB, who played an important role in supporting the development of this process and*

## MAPPING AND MONITORING

### Monitoring Systems

*coordinating and harmonising the different emerging monitoring initiatives, has recognised from the outset the need for a coordinated leadership of the Ministries offices and an alignment of National governments requirements with local government’s capacity.*

*In Swaziland, the scale up of a pilot mapping initiative to a country-wide mapping process was ensured by the strong institutional leadership and engagement of the Swaziland Rural Water Supply Section of the Ministry of Natural Resources and Energy. The recognition and ownership of the mapping process by national and local governmental office promoted process by-in and data use by different stakeholders*

### 2. Context –related process, adapted to local capacity

Water points monitoring processes design, including data collection and analysis, should be context-specific to ensure local capacity to uptake, maintain and sustain the process. The process design should therefore:

- Build on existing information flow, responsibilities and accountability dynamics
- Align with local technical capability of stakeholders involved in data collection, analysis and use. Tools and systems should be acceptable and adequate to local capacity and willingness to use and process should be appropriate to the local political, social context
- Include indicators for data collection relevant to local context, understandable by local stakeholders involved in sector monitoring and providing information of use at different decision-makers levels

*In Malawi an iterative process of reviewing and adapting the data collection, analysis and mapping procedures and tools, simplifying the original georeferenced data mapping to a simpler community-based information aggregation, allowed to identify and develop a regular monitoring process suited to local capacities (therefore with increased likelihoods to be used and maintained) and which also aligned with core information needed by district government for planning (therefore providing information of actual use).*

*In Mali the use of data analysis tools not suited to local capacity (particularly GIS for data analysis and maps generation and inclusion of complex hydrogeological indicators) led to dis-engagement of local governments from data analysis and mapping processes. A simplification of the indicators and tools used for data analysis led to increased ownership and use of the information derived by local government.*

### 3. Participated & coordinated processes

When introducing or developing/improving monitoring or mapping processes, seek and ensure strong sector players’ co-ordination and collaboration at all levels throughout the process, in combination with clearly defined roles and responsibilities. This includes national and local governments (WASH related but also associated agencies such as for health and agriculture), regulators, NGOs, other sector agencies, handpump mechanics associations (if existent), private sector etc. This is required to ensure:

- Definition and agreement on common and harmonised indicators, data collection, strategy and objectives responding to different information needs and allowing for increased data consistency across the sector
- Closed feedback-loop of information to local stakeholders to inform services planning
- Reduce indicators inconsistency and non –aligned duplication of monitoring processes by different actors

*In Mali, the monitoring initiative was conceptualised at local level within small decentralised administrative units without involvement and buy-in from of national government and national hydraulic agencies. This reduced the capacity to institutionalise the local mapping process within the national water services monitoring initiatives (i.e. link with SIGMA database), reduced the buy-in of the information derived and did not profit of the technical support available from national agencies, overall reducing the long-term sustainability of the process.*

## MAPPING AND MONITORING

### Monitoring Systems

*In Liberia, the national water point mapping inventory, although funded by external agencies was led primarily by three government ministries and had defined clear roles and responsibilities at start. The strong stakeholder coordination and collaboration allowed to fasten the inventory completion process, however did not achieve development of a long-term data updating strategy.*

#### 4. Continuously adapting and improving processes

Monitoring and mapping processes need regular review of indicators, processes and systems used for continuous improvement and adaptations to observed challenges and requirements changes.

*In Malawi the iterative critical review of monitoring and mapping indicators, processes and tools allowed identification of challenges and bottlenecks of the process and through iterative progressive changes and adaptation, evolved into a process which permits regular rural water services monitoring through use of local capacities and existing information flow and resources (therefore with increased likelihoods to be used and maintained).*

#### ii. ICT & innovative tools for monitoring are enablers and means to an end

The recent collaborative research Making All Voices Count (MAVC) with IRC and itad, analysed how ICT can support information flow on water supply and lead to increase duty bearers' response. ICT has been identified as a catalyst to encourage citizens' reporting on services faults, receive information on service quality and overall to increase accountability relations between citizens, service providers and policymakers. The MAVC research aimed to understand the factors and conditions which actually empower citizens' voice to consequently achieve improved service delivery through successful ICT-based reporting and processing data. A Qualitative Comparative Analysis (QCA) was performed on 8 different initiatives to evaluate the key factors for success or failure in achieving functionality of the ICT mechanism (successful ICT reporting), processing of ICT reports by governments or service providers and service improvements (i.e. water scheme repairs) as a result of the reports. From this analysis a number of important learnings were identified (Williams et al. 2015).

- To ensure functionality of the overall ICT-based reporting process the **social and technical process design needs to be adequate for the specific end-users** (i.e. selection of preferred communication system: SMS/ phone calls, ensure users trust and willingness to engage etc.) and in alignment with available technical capacity (mobile phones availability, re-charging and internet connection).
- The main condition for successful information processing is the **responsiveness of the service provider** to any ICT-based communication: the urban-based ICT initiatives which had clear roles and responsibilities for service provision were more successful that crowdsourcing initiatives reporting on rural water point's breakdown.
- Key factors for successful service improvement are dependent on the **service delivery model** and depend on availability of sufficient funds, spare parts, access to a mechanic and clarity about operation and maintenance procedures among all actors.
- A key differentiator between successful and unsuccessful initiatives was whether the **operational costs for data collection and reporting were largely met** by the service provider, government agency or NGO supporting the initiative rather than relying on volunteer contributions of communities and end-users.

Overall it was concluded that successful ICT initiatives – Smart Handpumps, MajiVoice and Next Drop – were all characterised by a **leading role of the service provider**. This concludes that to ensure successful use of rural water supply ICT-monitoring a demonstrated commitment to responsiveness from the service provider to ensure maintenance services is required. On the contrary crowdsourcing reporting initiatives based on the social accountability model, where citizens hold the service provider or policymaker to account via reporting water point breakdowns, service interrup-

## MAPPING AND MONITORING

### Monitoring Systems

tions or poor quality, do not autonomously lead to successful changes in services levels (Williams et al. 2016)

#### iii. WaterAid’s current view of sector monitoring status

A recent survey\*\* was carried out across the countries where WaterAid is currently operating to understand the organisation understanding and view of the current trends and challenges of sector monitoring at country level. The received responses have confirmed that increasing number of countries are introducing or developing national water services databased or Management Information Systems to support sector decision making however it was identified that some important challenges of sector performance monitoring still persist and need addressing, particularly:

- **Presence of multiple and uncoordinated parallel water services monitoring systems** and processes, often run by different agencies and organisations, including INGOs and donors. Many non-governmental implementing agencies perform project monitoring for funders’ reporting purpose and rarely contribute to broader national monitoring processes or ensure data sharing. This leads to fragmented datasets, duplication of efforts, and ineffective use of resources and finally causes inconsistent access and use of sector information to inform interventions.

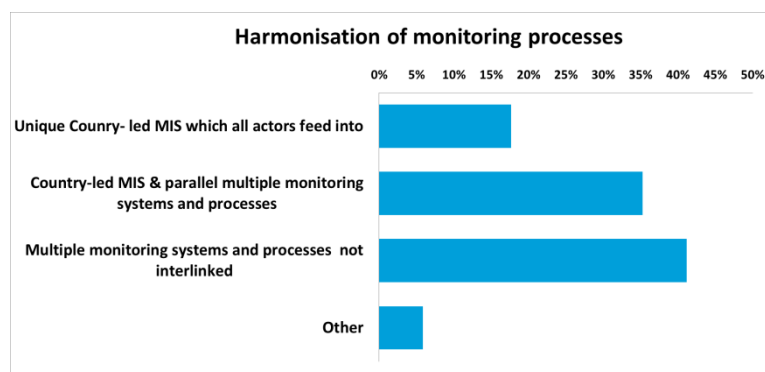

**Figure 1. WaterAid Country Programmes’ assessment of monitoring processes harmonisation**

- **Low access to water services data by rural local governments** mostly due to poor connectivity as most developed rural water services databases are web-based or because they sit in central offices (**Error! Reference source not found.**) Indicating limited presence of data feedback loops and ownership of information from local governments. This **limits local government’s use** of the information for local water services planning, management, maintenance and resources allocation (**Error! Reference source not found.**). This is often a result of incomplete decentralisation of responsibilities, capacity and financial allocation, repeatedly observed in the WASH sector.

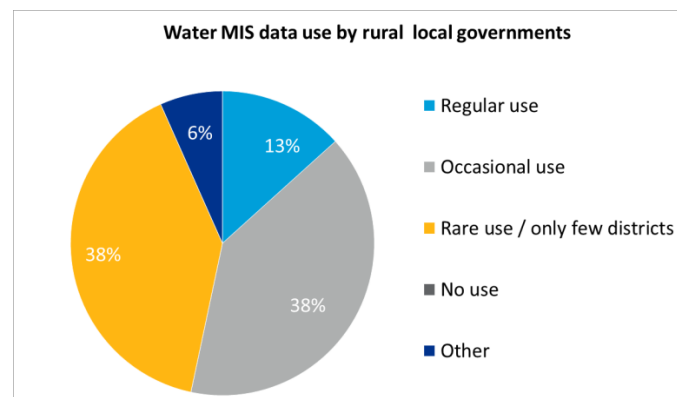
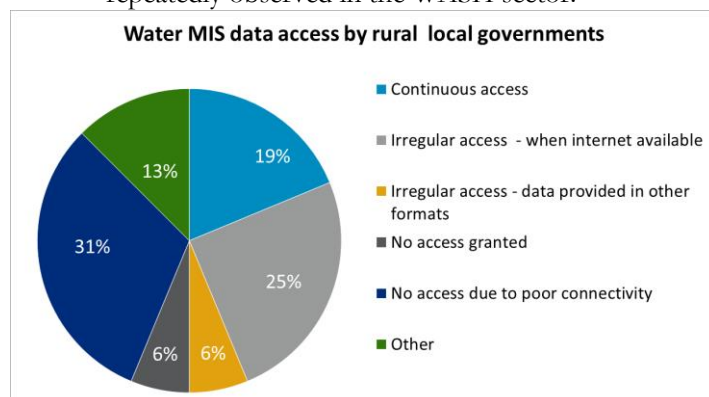

## MAPPING AND MONITORING

### Monitoring Systems

Figure 2. WaterAid CPs assessment of data access by rural local governments

- The current **main challenges and limitations for sustaining the national and sub-national monitoring & MIS** identified include insufficient harmonisation and coordination of the sector, resources constraints (both financial and human resources) for data collection and updating, insufficient capacity for data collection, updating and analysis and the impact of high staff turnover in local governments offices and the lack of incentives for reporting

Figure 3. WaterAid CPs assessment of data access by rural local governments

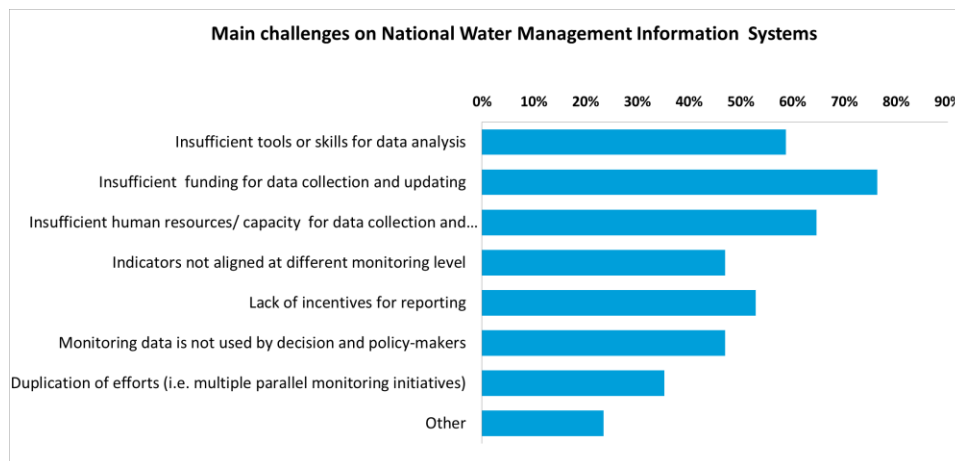

Figure 4. WaterAid CPs assessment of challenges of National / Country-led water monitoring

## Conclusions and Recommendations

### Proposed approach to support sector monitoring

In this paper we have reviewed lessons learned from a variety of experiences and contexts. Based on these the following approach to support sector monitoring through three phases is being recommended (also summarised in the building block diagram below)

#### Phase 1- Analysis of current sector performance monitoring status and gaps to identify:

- Current status and gaps in staff capacity; monitoring practices; how data is collected and how information flows around the sector (and also in related sectors) and is being used at different levels (national and subnational);
- Current national government framework and policy which regulates and controls services monitoring practices (resources, roles and responsibility)
- Opportunities to strengthen the overall monitoring process from data collection to data use at local and national level.

#### Phase 2 - Develop and test context related and sustainable approaches and processes for regular monitoring that support addressing gaps identified in Phase 1

- Identify and test institutionalised, context-related, scalable and sustainable (financially, capacity etc.) models based on and building on existing resources and data collection processes. These should aim to address key monitoring processes gaps particularly for data analysis and regular data updating. In alignment with district wide approach and decentralisation policies, efforts should focus on sub-national level processes (led by local governments), although in alignment with National M&E framework and policies.

Support development of monitoring building blocks:

- Presence of infrastructure inventories

## MAPPING AND MONITORING

### Monitoring Systems

- Selection of context related and meaningful indicators to inform service level status. These should be aligned with broad sector and national indicators
  - Regular monitoring processes to be sustained with existing or minimal costs (based on enumerators, citizens’ feedback or existing data collection processes)
  - Context and local capacity–suited tools to support data collection and analysis processes
  - Develop processes for data dissemination across the sector
- b. Ensure processes above are institutionalized and uptaken by local governments and other service provider
- c. Assess opportunity to use data sharing platforms to ensure data is being disseminated and used by all sector actors.

### Phase 3 - Support the presentation, dissemination, interpretation and use of WASH service data so that more evidence-based decision-making is done.

1. Support processes for data use for informed decision making, particular at sub-national level and dissemination to sector stakeholders
2. Ensure data is accessible and understandable by those who needed it all levels. In particular at local level, support government with data storage, analysis and use.

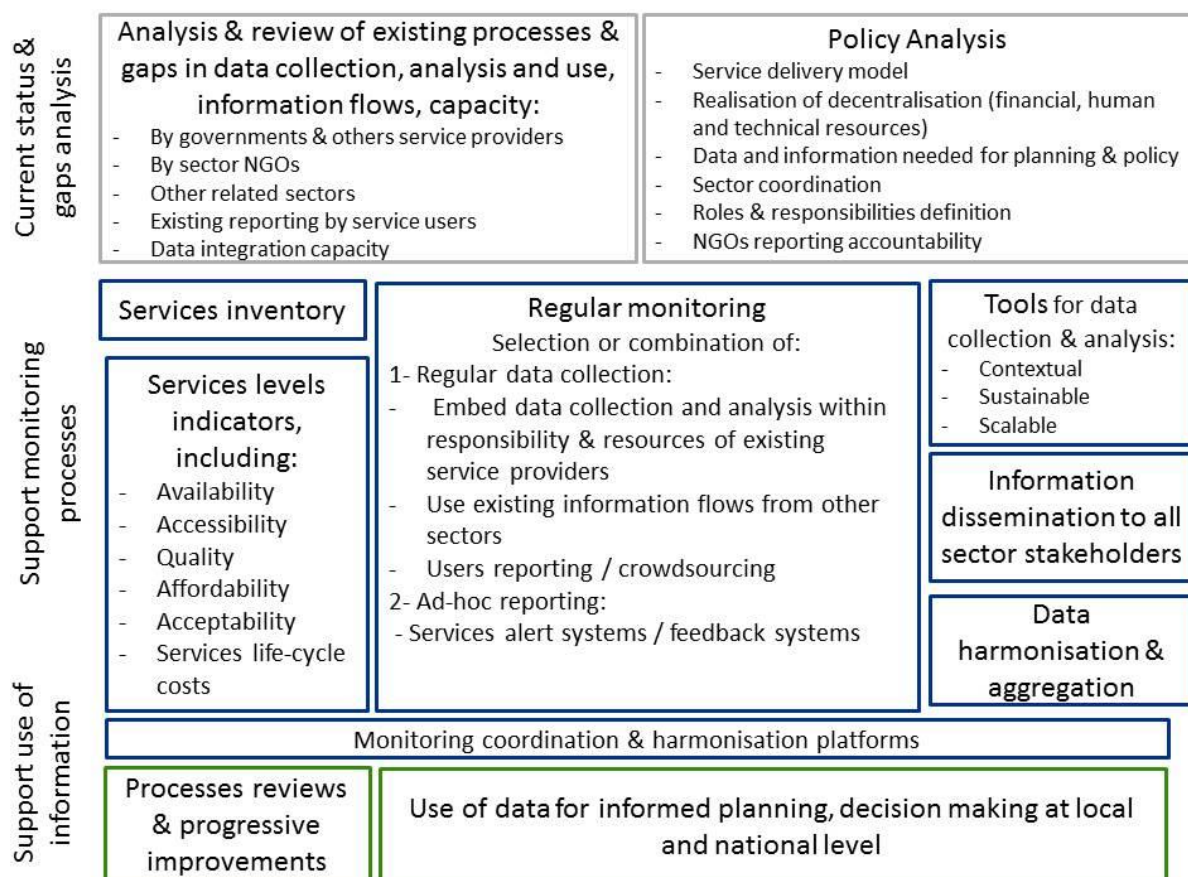

In addition, internal WaterAid organisational monitoring initiatives, as other NGOs, could support identifying good practices and approaches for monitoring processes, particularly at district level. In WaterAid some learning around service level monitoring could be derived from the findings of the organisational internal sustainability monitoring initiative, PIMS (Post Implementation Monitoring Survey). A number of water, sanitation and hygiene indicators and survey questions have been developed and tested to ensure significant data is being collected and can be analysed. Furthermore, WaterAid

## MAPPING AND MONITORING

### Monitoring Systems

internal use of mobile based data collection through the mWater platform, has demonstrate the benefits of accelerating information flow, improving data quality and facilitating data analysis and reporting.

### Moving forward – WaterAid support priorities for strengthening sector monitoring

While a number of WaterAid country teams are supporting national monitoring processes- Joint Sector Reviews, sector coordination, sharing monitoring data with national or district governments the main support functions performed by WaterAid’s country programmes (based on the above described survey) have focused on:

- Data collection / survey tools training (65% of WaterAid Country Programmes)
- Funding data collection on WASH services in certain districts (53% of WaterAid Country Programmes)

To address the gaps in services monitoring informing the delivery and maintenance of sustainable services, WaterAid’s country programmes have now highlighted the need to shift the support provided towards supporting gaps and challenges of country-led (at national and local level) services monitoring processes and particularly updating mechanisms and use of data to inform evidence-based planning.

These priority areas will be addressed by building on past experience and learnings and ensuring sustainable systems and processes are introduced.

### Acknowledgements

*Vincent Casey, Claire Grayson*

### References

- EWB (2014) , Engineers Without Borders, Water & Sanitation - Malawi,  
[http://my2.ewb.ca/site\\_media/static/library/files/1241/a-national-monitoring-system-for-rural-water-supply-and-sanitation.pdf](http://my2.ewb.ca/site_media/static/library/files/1241/a-national-monitoring-system-for-rural-water-supply-and-sanitation.pdf)
- JMP (2015) WASH Post-2015 Proposed indicators for drinking water, sanitation and hygiene
- Moriarty P., Smiths S., Butterworth J., Franceys R (2013) Trends in rural water supply: towards a service delivery approach. *Water Alternatives* 6(3):329-349
- Schouten T and Smith S (eds) (2015) From Infrastructure to Services: trends in monitoring sustainable water, sanitation and hygiene services, UK: Practical Action Publishing
- WaterAid - Ian Ross and Kristof Bostoen (2010) Data reconciliation in Southern Africa, Report on a regional workshop looking at monitoring approaches in the water and sanitation sector
- WaterAid in Tanzania, Hucks L & Axwesco F (2011) East Africa data reconciliation workshop, WaterAid, WHO, UNICEF.
- Williams, J.; Welle, K.; and Pearce, J. (2015) Testing the Waters. A Qualitative Comparative Analysis of the Factors Affecting Success in Rendering Water Services More Sustainable Based on ICT Reporting. Brighton: Making All Voices Count. <http://www.makingallvoicescount.org/project/closing-the-knowledge-gap-in-using-icts-to-improve-rural-water-supply-sustainability/>
- Williams, J.; Welle, K.; and Pearce, J. (2016) How can ICT initiatives be designed to improve rural water supply? Brighton: IDS and WaterAid.
- \*The referred country case studies will be available as appendix to this paper.
- \*\* Further details and information on WaterAid survey can be provided if necessary

## MAPPING AND MONITORING

### Monitoring Systems

---

# Introducing ICTs for WASH monitoring in Ethiopia

---

Type: Long Paper (up to 6,000 words)

**Authors** Tamene Hailu Debela (Rural WASH Coordinator, Ministry of Water, Irrigation and Electricity, Ethiopia, tamenehd@yahoo.com, +251 911434154), John Butterworth, Joseph Pearce, Desta Dimtse and Henok Getachew

### Abstract/Summary

This paper reviews national WASH sector monitoring in Ethiopia, and recent experiences seeking to improve the related monitoring capacities, processes and systems with a focus on the introduction of new information and communications technology (ICT). The complex enabling environment for WASH monitoring that spans multiple key institutions is mapped, capacity constraints summarised, and recommendations made to promote greater coordination and collaboration across government and wider sector efforts. Two recent federally-initiated initiatives to introduce ICT technologies in the WASH sector are assessed – the development of a management information system for national WASH and the use of mobile-based data collection tools in National WASH Inventory in Somali region – with lessons learned on using ICTs to better update datasets, sustain national monitoring capacities and make full use of the data collected. Finally the paper reviews the current landscape of WASH ICT experimentation, particularly by NGOs, identifying possible strategies to harness capacities across the WASH sectors in support of government-led monitoring processes.

### Introduction

Government-led nationwide WASH monitoring is a critical component of the necessary enabling environment to achieve the Sustainable Development Goals. The Sanitation and Water for All (SWA) partnership, for example, emphasises the need for a good evidence base and strengthened government-led planning processes as current top priority issues together with higher political prioritisation (SWA, 2016). This paper discusses national Water, Sanitation and Hygiene (WASH) sector monitoring in Ethiopia, and recent experiences seeking to improve WASH monitoring capacities, processes and systems with a focus on the introduction of new information and communications technology (ICT). ICT is creating new opportunities and possibilities for WASH monitoring linked to new mobile phone and internet technologies (Welle *et al.*, 2015; Fisher *et al.*, 2016) that a wide range of sector actors are seeking to capitalise on within the country.

WASH services in Ethiopia are gradually being transformed through a series of innovations and reforms under the umbrella of the One WASH National Programme (OWNP). The OWP is a sector-wide approach to WASH involving four key government ministries and their related sub-sectors to improve the way WASH services are delivered to people (FDRE, 2013). This combines the efforts of the Ministry of Water, Irrigation and Electricity (MoWIE), Ministry of Health (MoH), Ministry of Education (MoE) and the Ministry of Finance & Economic Cooperation (MoFEC). Coordinated by the National WASH Coordination Office (NWCO) it brings together government, development partners and Non-Governmental (NGO) activities in WASH in a coordinated programme with total planned programme investments exceeding USD 2.4 billion (2013-2020).

The aims of the OWP are to improve the health and well-being of communities in rural and urban areas by increasing equitable and sustainable access to water supply and sanitation, and the adoption of good hygiene practices. The programme combines a comprehensive range of water, sanitation and hygiene



## MAPPING AND MONITORING

### Monitoring Systems

interventions that include capital investments to extend first-time access to water and sanitation as well as investments focused on developing the enabling environment, building capacity, ensuring the sustainability of service delivery, and behavioural change. The scope includes WASH provision for households, rural and urban communities, and schools, health and other institutions.

So that results can be tracked, and ultimately improved, the OWNPs plans include strengthening national WASH monitoring and evaluation (M&E) systems. OWNPs M&E objectives include: 1) to measure and report progress towards the intended OWNPs results, and 2) to strengthen accountability of the WASH sector at all levels (i.e., federal, regional, town and Woreda) through the use of data and information from the WASH M&E system.

### Description of the Case Study

This paper summarises the current status and enabling environment for national-scale WASH M&E and reviews experiences and initiatives to introduce ICT in WASH monitoring. The paper is largely based upon the findings of an inception phase of managerial and technical support provided by IRC to NWCO on behalf of Coffey International Development and with funding from the UK Department for International Development. Further information is provided in the diagnostic review of OWNPs M&E (Coffey/IRC, 2015) and assessments of M&E capacity (IRC, 2015a) and the WASH M&E Management Information System (MIS) (IRC, 2015b).

The paper reviews three issues in WASH monitoring:

- The current enabling environment in Ethiopia for country-led WASH monitoring
- Recent federally-initiated initiatives to introduce ICT technologies
- Other ICT introduction efforts, particularly by Non-governmental organisations (NGOs), and possible strategies to harness capacities across the WASH sectors

### Main results and lessons learnt

#### *Existing practices and the enabling environment for country-led WASH monitoring*

##### *Coordinating to link sectoral and fragmented processes*

Under the OWNPs, the WASH sectors are working towards ‘one plan, one budget, and one report’. Such streamlining aims to reduce the administrative and reporting burden on critical staff and improve efficiency, but at the same time, should enable the telling of a full and complete story about WASH, and actions to address implementation issues (using evidence) to improve coordination. However, the existing WASH landscape is rather fragmented and complex, with numerous programmes, plans, financing channels and reports across the WASH sectors. Table 1 summarises the key monitoring reporting processes within government related to WASH including the three main implementing sectors and finance as a supporting ministry. Further data is collected through the household surveys administered by the Central Statistical Agency. M&E responsibilities and efforts are typically fragmented (even within government) because of the complex financing arrangements in WASH sectors and the many different Ministries, Departments, Offices, Processes, Subprocesses and Case Teams involved. Fragmented responsibilities result from the many different funding modalities, for example the block grant, consolidated WASH account, bilateral and multilateral (UN) programmes and projects, NGO projects and emergency WASH interventions. Integrated WASH monitoring through combined data collection processes is a fairly recent development, through for example the National WASH Inventory in 2010/11. There have to date also only been occasional integrated reporting efforts, at largely federal level, that have not been fully successful or sustained and a comprehensive annual sector report remains a major gap at national as well as lower levels.

**Table 1: Governmental monitoring processes related to WaSH**

Processes	Water	Health	Education	Finance	CSA	Integrated WASH
-----------	-------	--------	-----------	---------	-----	-----------------

## MAPPING AND MONITORING

### Monitoring Systems

Processes	Water	Health	Education	Finance	CSA	Integrated WASH
Data collection (and reporting frequency)	Critical coverage and functionality indicators are calculated based upon data that is reported by woreda water offices (rural water) and urban water supply utilities. Quarterly reporting processes are extensive, but based upon none standard indicators and variable definitions.	Data is collected frequently (monthly, quarterly and annually) by health extension workers and reported through health centres to woredas.	Annually from all schools under supervision of supervisors.	Quarterly from WoFED, BoFED, etc.	Household surveys employing trained enumerators. Generally survey designs with sampling to provide nationally-representative data.	Not routine. Major recent examples of integrated data collection were NWI 2010/11 (NWI in Somali excluded the household sanitation components) and collection of data from regions through standard formats for the (Consolidated WASH account) CWA annual report.
Data processing	Generally done manually with desktop software, e.g. Excel.	Managed by diploma-holding expert at Woreda level who transcribes paper-based submissions and generates CDs with results. Their computer is highly regulated to prevent viruses and reduce maintenance requirements.	Regions aggregate results from paper forms using Excel and submit this to MoE who manage the data in an Access database.	Data processing occurs in IBEX.	Centralised in CSA	NWI data was entered into a custom-made Access database. Most analysis in Excel. Some data from 2010 has been imported into the WaSH M&E MIS by PUT.
MIS/ analysis	Rural and urban water supply included in WaSH M&E MIS but this is not yet operational. Excel is standard for analysis.	HMIS only allows calculations for the limited indicators included.	EMIS data is analysed on an annual basis.	IBEX is currently used to generate reports. MoFED is currently piloting a new Integrated Financial Management Information System (IFMIS).	There are a number of web platforms to generate indicators from CSA, e.g. CountryStat Ethiopia. Many datasets are created by CSA analysts	WASH M&E MIS not yet operational but under implementation.
Reporting	Annual reports are prepared by Planning Department (MoWIE wide) and by Water Supply and Sanitation Directorate for various donor projects and programmes. Reports disseminated in sector meetings such as the Multi-Stakeholder Forum (MSF).	MoH publishes HMIS indicator results on an annual basis in its annual performance report. However, the key sanitation indicators have not yet been included.	An Education Statistics Annual Abstract is produced. A new National School WaSH Strategy and Guideline is expected to support improved reporting.	Budgets are published annually and financial information can be accessed through IBEX.	The CSA website provides access to publications and a number of web platforms for downloading analysis and datasets published on a regular basis. The naming and coding publication, critical for integrated reporting is not yet regularly updated (last updated in 2012)	The first OWN-P-CWA report was prepared in August 2015. However this was only integrated at federal level, and does not cover the whole country. Integrated reporting is not yet underway at regional or woreda levels.

Cooperation between the units managing information systems across WASH ministries and alignment of data from the different MIS systems across the WASH sectors is currently limited, and this hampers efforts to produce WASH sector wide reporting, for example to combine health data on sanitation and

## MAPPING AND MONITORING

### Monitoring Systems

education data on school WASH with water sector data on rural and urban water supply. Ministries do not yet cooperate sufficiently to ensure data sets are complementary, to avoid overlaps and to ensure timely sharing. A further challenge is presented by the decentralised nature of the country. Regions and woredas have substantial powers and a strong stake in what data shows. A typical gap (affecting financial expenditure data for example) is that as data flows up the system it loses value due to aggregation at the different levels (regions reporting consolidated woredas data to the federal level for example). More modern MIS systems have potential to make a major impact in this area.

Major surveys by the Central Statistical Agency (CSA) with WASH questions include the Demographic and Health Survey (every 5 years), Welfare Monitoring Survey (every 5 years), Household Consumption Expenditure Survey (5 years), and Census (10 years). Strong links have not yet been established between the wider WASH sector and the National Statistical System led by the CSA and there is potential for wider use of household survey data within the OWP if these links are strengthened, as well as learning from developments in M&E in other sectors. There are established governance arrangements to link NGO reporting to the OWP such as the consolidated reporting of the Christian Relief and Development Association (CCRDA) Water and Sanitation Forum, in addition to the agreement-related reporting requirements on NGOs to report to Finance and Economic Development at woreda, region or federal level. Efforts are also underway to strengthen this reporting.

In this context - a complicated grouping of subsectors involving numerous agencies - integrated WASH M&E could facilitate improved information flows and support coordination, with the OWP being able to more quickly monitor, evaluate and communicate its successes and failures. It could also help to realise the strengths of a multi-sectoral approach helping make links between water supply, sanitation provision and hygiene behaviours in decision-making.

#### *Capacity constraints*

Within MoWIE there are critical constraints with respect to human Resources development, resourcing more broadly including the physical and logistic resources needed to do M&E tasks, and the current supply of training and broader capacity building support (IRC, 2015a). M&E is perceived to have a lower priority than other core processes, and M&E staffing and training is not prioritised. There is high turnover of staff, numerous vacant positions (managerial, technical, expert and support) related to WASH M&E, limited or no financial resources and opportunities to build staff M&E capacity, and a generally low levels of skills in M&E and IT. There is relatively better capacity in health and education M&E, but WASH is not a focus or core competence in these sectors.

Resource gaps (physical, financial and human) between regions and woredas are also significant. Two regions, Tigray and Amhara, are mobilising kebele (sub-district) level water staffing and bringing the water supply sector into a position more similar to the health (with its health extension workers) and education sectors. Woredas with larger donor investments have generally higher capacity and are better equipped. Physical capacity relevant to M&E includes equipment and transport logistics. Although considerable ICT equipment are available at regional level, its use is hindered by a significant shortage of skills to manage and use it effectively. A lack of ICT facilities and equipment is notable from woreda level downwards although there are projects underway to roll out the supply of new computers. There are clear IT skills and systems constraints at all levels. A lack of transport facilities further hinders M&E.

Although the health sector has the strongest of the WASH sector monitoring systems, there is high turnover of HMIS experts who focus on a facilitating a flow of information rather than interpreting or responding to WASH data signals. Limited knowledge of sanitation and hygiene significantly impacts on health staff's ability to gather and analyse monitoring data and to compile accurate reports. Similarly, education departments are primarily concerned with education-related targets, and the positive correlation between improved WASH and achieving education targets is not foregrounded.

On the supply side, Technical and Vocational Education and Training Centres and Health Science Colleges train water technicians and health officers with M&E related content but overall training supply

## MAPPING AND MONITORING

### Monitoring Systems

is ad-hoc and there is a lack of continuity in training courses and no central coordinating body. There is also no system to monitor the efficacy or impact of training. The MoWIE Capacity Building Unit aims to tackle these issues but is not yet fully functional. Training on WASH M&E is limited, and where training exists it's on M&E generally and theoretically, plus there is a general bias towards water over sanitation and hygiene monitoring. Courses also tend to be one-off without a mechanism in place to update training when M&E systems are updated in keeping with sector changes, or when new staff arrive. Training materials are usually not available in local languages and are either not provided or not commensurate with the level of trainee groups. The availability of training materials after completing training courses is a key issue given the high turnover and attrition of M&E and sector personnel.

#### *National initiatives to introduce ICT technologies in WASH monitoring*

There are a large number of existing MIS systems that hold WASH related data at both national and local levels. These systems include, in health firstly, the Health MIS or HMIS (with 3 household sanitation indicators and 2 health institution indicators; located within the Health System Special Support Directorate) which is complemented by the Hygiene and Environmental Health directorates programme monitoring system (with four additional WASH indicators proposed). The Education sector also has an existing national level management information system in place known as EMIS (within the EMIS directorate) with School WASH indicators (3 key indicators) and annual reports include reporting on these indicators. Finance has the national Integrated Budget and Expenditure System (IBEX) system to manage public expenditure according to standard budget codes. All of these systems have gaps with respect to WASH indicators and the quality of data collected (see for example, Jones, 2015). However, these are all functioning national scale data collection and reporting systems within OWP implementing ministries.

The introduction of Information and Communications Technologies (ICT) to support M&E across the WASH sectors is however at an early stage. The Health and Education reporting systems are largely paper based (data becomes digital at woreda level in the HMIS and at regional level in the EMIS). There is no use at scale of internet and mobile communications technologies within these systems although pilots are underway with mobile data collection technologies in the health sector. IBEX is a series of standalone databases at regional level and is not networked. Data is sent to federal level by hardcopy official letter and sometimes by email. There is some variation in regions with data entry being done at woreda levels where infrastructure is better. Currently at federal level it is only possible to access consolidated regional data, so analysis possibilities are limited (Prat, et al. 2014). It is only possible to access woreda level data at the regional or lower levels. Data is re-entered at federal level. When IBEX is networked, starting in Tigray, woreda level data will be available up to federal level. Staff may then be able to dedicate more time to data analysis rather than data entry.

While IT-enabled MIS systems at national level are operational within the education, health and finance sectors, there is not yet a comparable national system in use in the water supply sector. Federal ministries, led by water, have taken important initiatives to improve WASH monitoring over recent years including through the deployment of new ICTs as these have become available. Success has been mixed to date, but there are critical lessons that can be drawn and used to help ensure further successful utilisation of newer generation ICTs, databases and visualisation solutions that offer ever improving capabilities.

#### *The development of the WASH M&E MIS using proprietary software*

A national system known as the WASH M&E MIS has been in development since 2008 with software handed over to MoWIE in 2015. The system was developed by local consultants Professionals Unite Together (PUT) and is based upon proprietary software applications (IRC, 2015b).

The WASH M&E MIS has been assessed to be functional with key functions possible as originally intended, but it is not operational i.e. is not in use. Most basic functions such as entering and editing data, generating analysis and outputting results are possible, despite a few bugs. Despite a large-scale roll out of training (to over 300 woredas which is about a third of the total) significant use of the system has not yet been triggered. A telephone survey in September 2015 of 24 regional, zonal and woreda offices found

## MAPPING AND MONITORING

### Monitoring Systems

that all had knowledge of the WASH M&E MIS database, and had received training but none reported using the MIS. These findings are consistent with interviews undertaken during a series of regional visits. The database at national level contains only 2010/11 NWI data that has been manually imported and new data is not yet being entered. The hardware and training roll-out (300 staff trained) have not as yet led to use of the system. Many of the 800 computers bought are still being distributed. Further hardware roll-out and training (500 more woredas staff) is currently being provided to other woredas that have not yet received support to use the system.

In its current status, the WASH M&E MIS lacks some characteristics considered necessary for operationalization, for example training and other support activities are not likely to be sufficient for widespread use of the system. There are also significant technical and operational challenges with the system and the testing processes that have been undertaken have not been sufficient to ensure that the system has met user requirements and capabilities. Critically the software is not yet user friendly (easy to use, meaning it is not difficult to learn or understand, and that it is simple, intuitive and reliable), or easy to reconfigure which is challenging given that it is now necessary to fully update the indicators with new requirements. For example, the Second Growth and Transformation Plan (GTP2) requires some new indicators to be adopted within the OWINP and others to be modified.

MoWIE have, until recently, received limited support in ICT procurement and weaknesses in the contracting of the WASH M&E MIS have proved a major headache. To address the current gaps in the system, plans to make use of the system now focus on its use for critical data archiving and reporting functions, with alternative solutions found for woreda-level data entry that are based on the use of mobile phone technologies.

#### *The National WASH Inventory and deployment of mobile-based data collection technologies*

A key achievement in WASH monitoring over the recent past has been the undertaking of the National WASH Inventory. In 2010/11, a huge and focused effort ensured the collection of basic data from all 93000 ‘improved’ rural water supply systems in the country (now there are estimated to be 160,000) as well as 50,000 schools and health institutions and 1600 towns (Welle, 2013). At that time, the Somali region was left out for logistical reasons, but good advantage was taken of this in 2014 when the survey was extended to the Somali region. By this time, new new mobile data collection technologies were available. The Somali inventory, under the leadership of MoWIE and with UNICEF support, used the Akvo FLOW app on smartphones to greatly improve the time to availability and the quality of data collection compared to paper-based data collection in other regions. Data entry, which was a major burden for regions following the 2010/11 exercise, was also eliminated as all details are logged using the phones in the field and data directly submitted to a database.

A major success of the NWI was an improved national estimate of access to improved water supplies, and the results were accepted and used by both the parliament and later the World Health Organisation (WHO)-United Nations Children’s Emergency Fund (UNICEF) Joint Monitoring Programme (JMP) in determining that Ethiopia had successfully met the MDG water target.

Nevertheless, even more use could have been made of the data. Limited investments were made in the analysis and dissemination of data either in the 2010/11 or 2014 Somali exercise. Future plans aim to invest resources in analysis and reporting to produce an accessible WASH atlas, and publish results as part of an annual OWINP report.

While the NWI was multi-sectoral in its WASH scope, and engaged health extension workers and teachers in data collection, it has not achieved the same level of ownership in the health and education sectors as in water who led the process. Going forwards the need has been identified to ensure that the NWI is further integrated into the ongoing monitoring efforts of all sectors, with duplication avoided.

Capacities or processes to update the NWI have also not yet been put in place. However, the intention is that as the NWI is repeated in 2016 to provide the baseline for future ongoing monitoring activities,

## MAPPING AND MONITORING

### Monitoring Systems

approximately 5 years after the previous nationwide data collection, capacities (both skills and tools such as the phones and applications) will be built at all levels, and especially the woreda level, to ensure that in future new systems are systematically added to the database and the changing status of existing systems (e.g. functionality) is properly tracked. This should make the need for any similar future NWI redundant. Rather it will be possible to focus on validating data for a sample of schemes, or collecting additional in-depth information through the survey since a basic, up-to-date database will already be maintained.

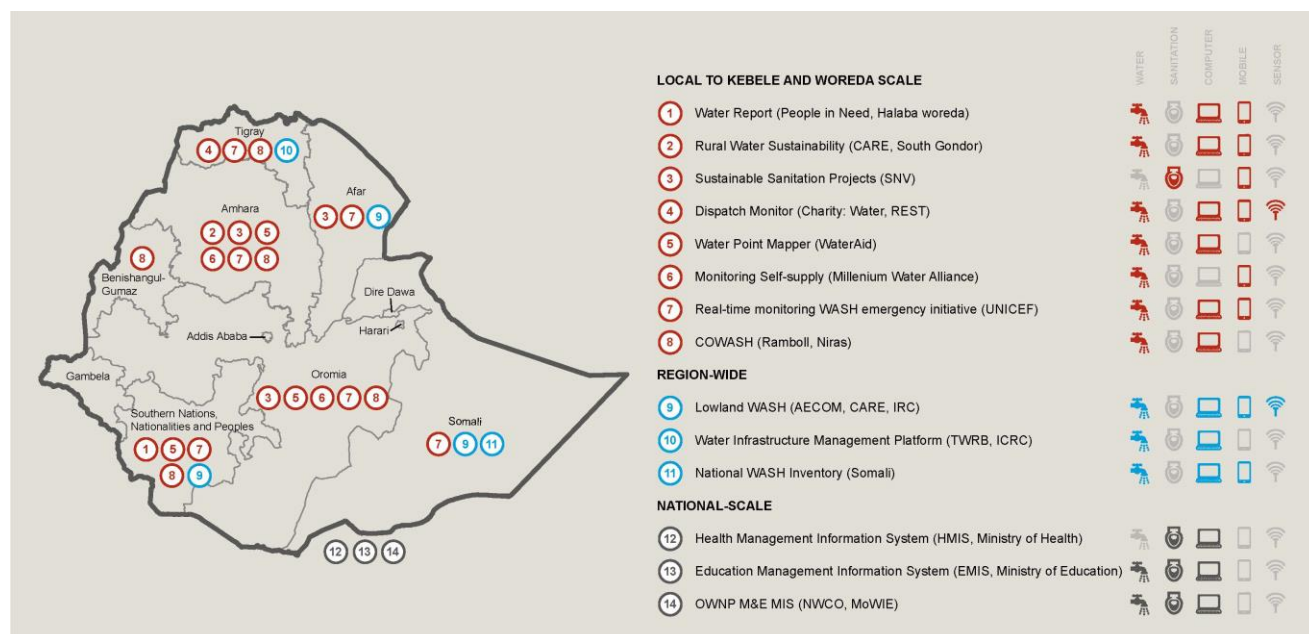

Figure 1: Some current initiatives introducing ICTs into rural WASH monitoring

### Other ICT initiatives in WASH monitoring

Figure 1 and Table 2 presents a first effort to map current and recent initiatives to introduce ICTs in rural WASH monitoring. The criteria for including initiatives were that they 1) focus on an aspect of rural WASH monitoring, 2) involve ongoing monitoring and reporting with government or local organisations rather than a one-off baseline, impact evaluation or short-term research effort (where tools such as Akvo FLOW and M-water are also widely used) and 3) include an ICT component. The initiatives cover a range of scales from a relatively small number of water points in a single woreda to whole regions. Figure 1 illustrates were initiatives focus on water or sanitation, the deployment of a computerised database or dashboard and the use of mobile phone and sensor technology.

Table 2: Some current initiatives utilising ICTs in rural WASH monitoring

Title	Location	Description
<i>Local to kebele and woreda scale</i>		
Water Report	Halaba, SNNPR	SMS based fault reporting system set up by NGO People In Need, with Woreda Water Office staff responding.
Rural Water Sustainability	South Gondor, Amhara	In 2015, Care supported local governments in South Gondor zone to map all the 2505 water supply schemes (and 195 institutional latrines) in 9 woredas using the mWater smartphone app.
Sustainable Sanitation Transformation	Amhara, Afar, Oromia	SNV use the Akvo FLOW system for M&E purposes within their sanitation programmes, Sustainable Sanitation Transformation in Urban and Peri urban areas (SSTPU) and Sustainable Sanitation & Hygiene for All (SSH4A).

## MAPPING AND MONITORING

### Monitoring Systems

<i>Title</i>	<i>Location</i>	<i>Description</i>
Dispatch Monitor EST	31 woredas in Tigray	Charity: Water/ REST's 'Dispatch Monitor' system logs and displays the water point status (functioning or needing repair) as reported by in-coming calls on free call line, AKVO FLOW spot-check surveys filed by program circuit riders, and sensors. There are currently over 3000 water points in the database, but these are only CW/REST schemes. Almost 1000 of these water points are fitted with sensors providing real-time data.
Water Point Mapper	Amara, Oromia, SNNPR and BSG	WaterAid Ethiopia is supporting use of its excel-based Water Point Mapper tool in 14 woredas in 4 regions (Amhara, Oromia, SNNPR and BG) by regional and woreda governments.
Monitoring Self-supply	Focus kebeles in 7 woredas in Amhara and Oromia	The Millenium Water Alliance are monitoring existing and new household-level water supply facilities that are constructed and improved through private investment. Akvo FLOW is used for surveys led by woreda government staff.
Real-time monitoring WASH emergency initiative	Woredas in Somali, Oromia, Amhara, Tigray, Afar, SNNPR	In 7 regions and in a total 70 priority woredas Akvo FLOW is being used for monitoring features to collect weekly data at all water points in the identified woredas. An automatic linkage has been setup between the Akvo FLOW system an the prototype online dashboard for data visualisations.
COWASH	CMP (Community Managed Project) woredas in Amhara, Oromia, SNNPR, Beninshangul, and Tigray.	COWASH uses handheld GPS devices and open source software (OpenOffice, QGIS). Capacity has been built at woreda-, zone-, and region-levels but the data is still mainly used at federal level. A1-size maps are generated for all COWASH woredas with an estimated 90% of water point data available for these woredas (in total 7827 waterpoint in the federal database).
<i>Region-wide</i>		
Lowland WASH	Afar, Somali, SNNPR	New project (AECOM/ Care/IRC/USAID) supporting the strengthening of WASH Management Information Systems in 3 regions, promoting the use of data for planning in 24 woredas, and involving installation of sensors on new and rehabilitated water supply schemes.
Water Infrastructure Management Platform	Tigray	The Tigray Water Resources Bureau (TWRB) manages WIMP which was developed with the support of ICRC on a web-based (Majella) platform. Rolled out to 34 rural woredas and working well in 18. These woreda water offices manage information on 15,279 water supply schemes. This system has been used regionally for official coverage calculations.
National WASH Inventory (Somali)	Somali region	The regional water bureau mapped a total of all 2914 rural community water supply systems, 22 urban facilities and 2386 institutional facilities within 22 actual days, with a total of 5696 records collected using Akvo FLOW app on mobile phones. Initiative led by MoWIE with UNICEF support.
<i>National-scale</i>		
Health Management Information System (HMIS)	Nationwide	National database including sanitation and hygiene indicators fed local health centres nationwide with data sent upwards to woredas, zones and regions by CD and internet.
Education Management Information System (EMIS)	Nationwide	National database including school WASH indicators with data entered at woredas and sent upwards to zones and regions (Access database). Aggregated data used to produce the Regional and National Education report.
OWNP M&E MIS (PUT)	Nationwide	National WASH database developed by consultants PUT for MoWIE. Based on proprietary software housed on servers at the National Data Centre connecting woredas by internet. Holds imported data from the 2010/11 National WASH Inventory.

## MAPPING AND MONITORING

### Monitoring Systems

The mapping illustrates the high level of interest and activity in the introduction of new ICTs for WASH monitoring. While it is challenging to generalise across such a wide range of initiatives at different scales, some identified trends are:

- NGOs are particularly active and a source of innovation in WASH monitoring. Examples include large International NGOs like Care and ICRC, water specialists like WaterAid or Charity: Water, small NGOs like People in Need and Ethiopian NGOs such as the Relief Society of Tigray (REST). WASH alliances, including the Millenium Water Alliance and the WASH Alliance International, are working to to promote standardised monitoring approaches across their NGO memberships and there is potential to use their scale to get NGOs behind government-led monitoring systems, and to learn valuable lessons from piloting in different areas.
- A shift from project monitoring by NGOs and projects towards supporting woreda-wide monitoring by regional and woreda governments is quite advanced. Examples include WaterAid, Care and ICRC. Others still have to make or support this step, and it is a recommended strategy.
- There is considerable use of leading sector applications such as Akvo FLOW and mWater apps for mobile-based data collection, and the country is developing substantial experience in the use of such tools. Care for example have used M-Water at zonal scale, and the government used Akvo FLOW at regional scale in the Somali NWI in 2014.
- A fairly recent and exciting new area of innovation is linking monitoring and messaging tools to the development and deployment of capacities to maintain water supply schemes. Examples include Charity: Water/REST's system where local teams will respond to breakdowns if existing government systems are unable to fix the problem, and SNVs initiative in Tigray to develop private sector capacities to repair water supply schemes with messages channelled from WASHCOs.
- Using new sensor technologies, some organisations are innovating to fit sensors to water pumps to provide real-time monitoring data. Charity; Water/ REST have been an early pioneer in the use of such technologies, with sensors now in use on almost 1000 schemes, and the Lowland WASH Activity are working with the company SweetSense to fit sensors to remote water supply systems in pastoral areas.

### Conclusions and Recommendations

At the outset, our analysis highlighted the huge scale of the challenge to build coherent WASH M&E processes and systems in a context of fragmentation and capacity constraints. The introduction of new ICTs clearly has potential to drive improvements. This is more likely to be the case if lessons are learned from existing ICT introduction efforts such as the development of the WASH M&E MIS and the NWI in Somali region. The final section on ICT initiatives highlights another side of the capacity coin. While government may have some capacity gaps for WASH monitoring and use of data in reporting and planning, there are significant additional capacities within NGOs, private companies and UN agencies. Many organisations are innovating and finding better ways to do WASH monitoring. To build on these initiatives and innovations and the related capacity that is being developed, it is recommended:

- To develop agreed standards, definitions and a minimum set of indicators that all are expected to adopt in order to promote alignment and synergies, rather than duplication, in WASH monitoring.
- To actively promote collaboration to harness the capacities of NGOs, UN agencies and others to support government such as encouraging moves towards support for woreda-wide rather than project or institutional-based monitoring. On its own, the latter is not enough and is unlikely to promote coordination.
- To promote use of data for all purposes at all levels, but particularly to promote use of data at the local level for operational purposes.
- To explore opportunities to drive improvements in the use of WASH M&E data through results-based payments, improved incentives or the commercialisation of some data use.
- To develop a network or community of practice to regularly share expertise and promote lesson learning and synergies between different efforts in WASH monitoring in Ethiopia.



## MAPPING AND MONITORING

### Monitoring Systems

#### References

- Coffey/IRC (2015) *Inception Report: Technical and Managerial Support for OWNPN M&E*. Coffey, Reading
- FDRE, Federal Democratic Republic of Ethiopia (2013) *One WASH National Program: A Multi-Sectoral SWAp*. FDRE, Addis Ababa.
- Fisher, M.B., Mann, B.H., Cronk, R.D., Shields, K.F., Klug, T.L., and Ramaswamy, R. (2016) Evaluating Mobile Survey Tools (MSTs) for Field-Level Monitoring and Data Collection: Development of a Novel Evaluation Framework, and Application to MSTs for Rural Water and Sanitation Monitoring. *International Journal of Environmental Research and Public Health*, 13, 840.
- Jones, Oliver (2015) *Monitoring Sanitation and Hygiene in Rural Ethiopia: A Diagnostic Analysis of Systems, Tools and Capacity*. Water and Sanitation Programme Technical Paper, World Bank, Addis Ababa.
- Welle, Katharina, Williams, J., and Pearce, J. (2015) *Testing the Waters: A qualitative comparative analysis of the factors affecting success in rendering water services sustainable based on ICT reporting*. IRC/ WaterAid/ ITAD report.
- Prat, M.A., Ross, I. & Kebede, S. (2014) *Value for Money and Sustainability in WASH Programmes: Assessing the VFM of DFID's contribution to the Water Supply and Sanitation Programme (WSSP) in Ethiopia*. Oxford Policy Management, Oxford.
- SWA, Sanitation and Water for All (2016) *Priority Areas*. Available at <http://sanitationandwaterforall.org/priority-areas/> [Accessed 26 August 2016].
- IRC (2015a) *WaSH M&E Systems: Existing Capacity Constraints*. Discussion Paper prepared by IRC/One WASH National Programme M&E Support Team. IRC Ethiopia, Addis Ababa.
- IRC (2015b) *Assessment of the WaSH M&E MIS*. Discussion Paper prepared by IRC/One WASH National Programme M&E Support Team. IRC Ethiopia, Addis Ababa.
- Welle, Katharina (2013) *Ethiopia National WASH Inventory: lessons learned and maximising value*. Seminar report. IRC, Addis Ababa.

## MAPPING AND MONITORING

### Monitoring Systems

---

# Implication des élus dans le suivi de la gestion du service public d'eau potable au Sénégal

---

Type: Article court

#### Auteurs

Daouda Sanon; Responsable institutionnel, Fondation ACRA, Sénégal, [daoudasanon@acra.it](mailto:daoudasanon@acra.it)  
Mario Milanesi; International Development Manager Water and Sanitation – Fondazione ACRA  
[mariomilanesi@acra.it](mailto:mariomilanesi@acra.it)

#### Abstract/Résumé

L'implication des élus locaux dans le service public de l'eau potable et de l'assainissement dans quatre communes de l'Arrondissement de Tenghory, région de Ziguinchor a été possible grâce à un projet pilote conduit par l'ONG ACRA la Communauté Urbaine de Cherbourg-Octeville (CUC) en France et des partenaires techniques et financiers notamment l'Union Européenne « *gestion durable, concertée et intégrée des sous-secteurs de l'eau et de l'assainissement ruraux dans le Département de Bignona via le renforcement des compétences locales* ». Pour la première fois au Sénégal en milieu rural, il a été possible de mener avec des élus locaux des actions pilotes de gouvernance du secteur eau potable et assainissement bien que la compétence ne soit pas encore transférée :

- Création formelle de commissions eau et assainissement ;
- Renforcement des capacités des élus locaux sur des thématiques du secteur ;
- Appropriation et mise à jour de l'outil de planification PLHA<sup>126</sup> dédié aux collectivités locales ;
- Signature d'un pacte d'intégrité sur la gestion et le suivi du service public de l'eau potable ;
- Implication des élus dans l'élaboration des plans de gestion de la sécurité sanitaire de l'eau ;
- Participation des élus aux cadres de concertations nationaux sur la problématique du sous secteur de l'eau potable et de l'assainissement en milieu rural.

Aujourd'hui grâce à ces actions d'appui et de renforcement de capacités des élus locaux, les questions d'eau potable et d'assainissement font l'objet d'une attention particulière lors des conseils municipaux sous le leadership des commissions communales eau et assainissement.

#### Introduction

Au Sénégal, la compétence eau et assainissement n'est pas encore transférée aux collectivités locales même si des textes, dont la Loi SPEPA<sup>127</sup>, n'en excluent pas la possibilité sous conditions. Avec le nouveau code des collectivités locales adopté le 28 décembre 2013, L'Etat ambitionne, avec l'Acte III de la décentralisation, organiser le Sénégal en territoires viables, compétitifs et porteurs de développement durable. Malgré cette situation institutionnelle et réglementaire non encore aboutie, les collectivités locales en milieu rural jouent un rôle important dans le service public d'eau potable et d'assainissement au niveau de la planification et la recherche de financement via le PLHA.

Depuis 2006, dans le cadre d'un programme d'eau potable et d'assainissement dans l'Arrondissement de Tenghory, région de Ziguinchor, l'ONG ACRA, la Communauté Urbaine de Cherbourg-Octeville (CUC) en France et les partenaires techniques et financiers notamment l'Union Européenne avec la facilité eau ont mis en œuvre un projet dénommé « *gestion durable, concertée et intégrée des sous-secteurs de l'eau et de l'assainissement ruraux dans le Département de Bignona via le renforcement des compétences locales* ». Dans son volet Gouvernance, ce projet a permis de poser les prémices du futur rôle des collectivités locales à travers des actions concrètes sur une période de trois ans (2012-2015).

---

<sup>126</sup> PLHA : Plan local d'hydraulique et d'assainissement

<sup>127</sup> Loi no 2008-59 Portant organisation du Service public de l'eau potable et de l'assainissement collectif des eaux usées domestiques.

## MAPPING AND MONITORING

### Monitoring Systems

#### Contexte, objectifs et activités

Dans le cadre des OMD 2005-2015, la cible 10, relative à l'objectif 7 pour le Sénégal en matière d'eau potable en milieu rural était de passer de 62 à 82% pour le taux d'accès. Si cet objectif a été globalement atteint voire dépassé à la fin des OMD avec 86,6% au plan national, il existe cependant de nombreuses disparités entre régions, départements et surtout communes du Sénégal.

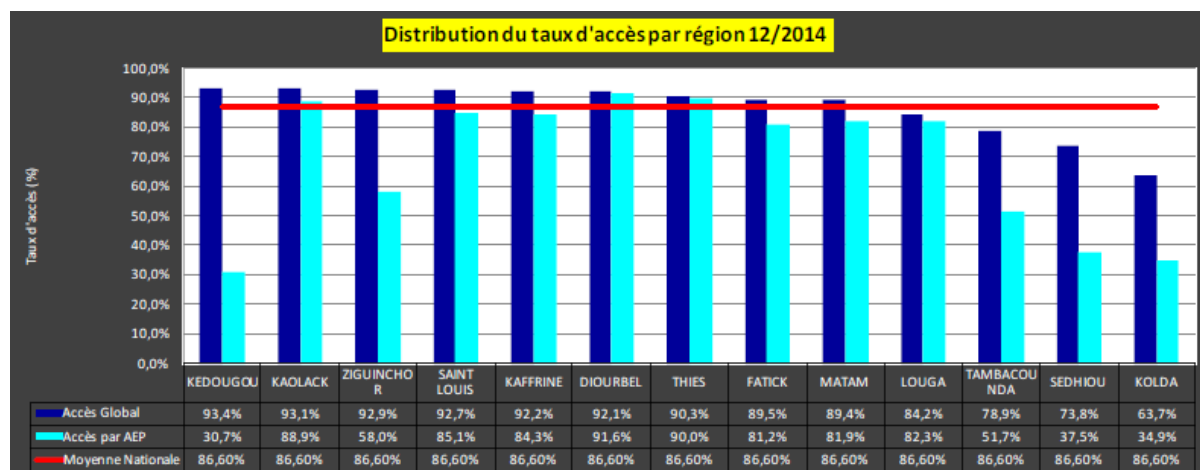

Figure 58

En effet, pendant que la moyenne du taux d'accès du pays est de 86,6% , les régions du Sud (Casamance naturelle) ont respectivement : Ziguinchor 58% ; Sédhiou 37,5% et Kolda 34,9%.

L'ONG ACRA a donc développé le projet dans la région de Ziguinchor I où le taux d'accès se pose avec acuité du fait de son enclavement et du conflit de trois décennies qui a contribué à freiner les investissements.

C'est dans ce contexte que le projet « gestion durable, concertée et intégrée des sous-secteurs de l'eau et de l'assainissement ruraux dans le Département de Bignona via le renforcement des compétences locales » a été conduit de 2012 à 2015 dans l'Arrondissement de Ténghory qui regroupe quatre communes.

Le volet Bonne gouvernance et implication des élus dans le suivi de la gestion du service de l'eau potable et de l'assainissement avait pour objectifs de tester la capacité des collectivités à s'approprier leur mission de planification et de suivi dans le cadre du PLHA mais aussi faire des plaidoyers auprès des autorités nationales et partenaires techniques et financiers.

Cela a donné lieu à la mise en œuvre de plusieurs activités, dont les principales ont été :

- Création des commissions communales eau et assainissement

A l'instar des autres commissions du conseil municipal, la Commission eau et assainissement (CEA) a été constituée conformément aux dispositions du code des collectivités locales. Elle est chargée de suivre toutes les questions relatives à l'eau et l'assainissement sur l'étendu du territoire communal, informer les autres élus au cours des sessions du conseils et éventuellement proposer des textes en vue de délibération. Elles sont composées d'une moyenne de 8 personnes sous l'égide d'un président. Avant leur création, toutes les questions eau étaient directement gérées et traitées par le Maire.

- Renforcement des capacités des élus sur des thématiques eau et assainissement

Pour agir de façon plus efficace, les élus des CEA avec l'équipe du projet ont participé à l'identification des thèmes de formation en vue du renforcement de leur capacité.

Les différents modules de formations qui ont été dispensés par les experts nationaux ont portés sur :

- ✓ La maîtrise d'ouvrage et la bonne gouvernance ;
- ✓ La présentation d'un exemple de coopération décentralisé dans le sous secteur de l'eau et l'assainissement Cherbourg et Coubalan ;

## MAPPING AND MONITORING

### Monitoring Systems

- ✓ Le code des marchés publics ;
- ✓ La loi sur le Service public d'eau potable et d'assainissement du Sénégal (Loi SPEPA) ;
- ✓ Les codes de l'eau, de l'assainissement et de l'environnement ;
- ✓ Le code général des collectivités locales.

#### - Appropriation et mise à jour des PLHA

Le plan local d'hydraulique et d'assainissement est un outil de planification qui a été élaboré de manière inclusive sur une période de cinq ans pour l'atteinte des OMD volet eau potable et assainissement par les communes. Malheureusement très peu d'élus dans les collectivités locales du Sénégal l'ont utilisé. C'est la raison pour laquelle le projet a accompagné les quatre communes de l'Arrondissement de Tenghory pour une meilleure appropriation de l'outil d'une part mais aussi et surtout sa mise à jour d'autre part. A ce jour chaque élu dans la collectivité locale connaît les besoins en eau et en assainissement de sa commune grâce aux échanges sur la question au cours des sessions du conseil municipal.

#### - Signature du pacte d'intégrité sur l'eau avec les acteurs de l'Arrondissement

La bonne gouvernance est subordonnée à la transparence, la participation, la lutte contre la corruption et la rédevabilité. Cet outil TPAR a été développé pour le réseau WIN (Water Intégrité Network) en plusieurs séances et a permis d'aboutir à la signature d'un pacte d'intégrité sur l'eau entre acteurs impliqués dans le service de l'eau sous l'égide de l'autorité administrative de l'Arrondissement le Sous-Préfet. Ce pacte constitue une expérience originale au Sénégal. Son but est de créer une confiance dans les procédures avec le TPAR et garantir le respect des règles de jeu par toutes les parties prenantes.

#### - Implication des élus dans l'élaboration des plans de gestion de la sécurité sanitaire de l'eau

La fondation ACRA a développé un volet qualité de l'eau dans le cadre du même projet dénommé PGSSE. En raison de son caractère inclusif, les élus des CEA et les Maires ont été fortement impliqués dans le processus depuis la formation sur l'outil PGSSE jusqu'à la signature et le suivi de la mise en œuvre.

Les résultats des analyses des eaux par le laboratoire d'analyse et de traitement des eaux sont régulièrement partagés avec les élus locaux notamment les commissions eau et assainissement et le Sous-Préfet.

#### - Voyages d'échanges des élus des collectivités

Des voyages d'échanges à l'intérieur du Sénégal, au Burkina Faso et en France ont été organisés par le projet afin permettre aux élus et d'autres acteurs locaux du projet de connaître d'autres expériences de gestion du service public de l'eau potable dans les milieux similaires. Une formation a été organisée en France par la CUC, notamment sur le rôle de élus locaux, les mécanismes de planification et la prise de décision.

Une approche comparative a permis aux élus de voir les dynamiques des autres collectivités en fonction des réalités sociales, économiques et politiques.

#### - Participations des élus aux cadres de concertations nationaux

Pour donner plus de visibilité aux activités du projet, des cadres de concertation nationaux ont été organisés au plan national pour partager les actions pilotes mises en œuvre. Les élus des quatre collectivités locales y ont régulièrement participé et ont partagé leurs expériences en termes de défis et d'innovations dans le secteur de l'eau potable et de l'assainissement au Sénégal. Ces cadres qui ont enregistré les responsables nationaux du Ministère en charge de l'hydraulique et de l'assainissement, les partenaires techniques et financiers, l'association des collectivités locales, les universités ont servi de tremplin pour des propositions dans le secteur de l'eau sur la gestion du service, la tarification et la qualité de l'eau en milieu rural. Il est ressorti aussi que certains pays de la sous région comme le Bénin, le Burkina Faso, le Mali ont déjà franchi certaines étapes dans le processus de transfert de la compétence eau potable et assainissement aux collectivités locales avec des réussites même si des efforts restent à fournir.

## MAPPING AND MONITORING

### Monitoring Systems

#### Résultats principaux et leçons tirées

Ce projet pilote a permis d’atteindre les principaux résultats suivants :

- Formalisation de commissions eau et assainissement au sein des conseils municipaux concernés ;
- Formation, renforcement de capacité et voyages d’échanges des membres des commissions eau et assainissement sur les problématiques liés à l’eau et à l’assainissement ;
- Appropriation des PLHA par les commissions eau et assainissement à travers leur mise à jour ;
- Signature d’un pacte d’intégrité par les différentes parties prenantes sur la gestion des réseaux d’eau potable
- Validation et suivi de l’outil PGSSE par les autorités locales ;
- Nécessité désormais pour les ASUFOR de rendre compte de la gestion du service de l’eau à la commune son rapport d’exploitation périodique ;
- Implication de la commune dans les décisions de fixer ou de modifier le prix de l’eau
- Suivi de la qualité de l’eau par les autorités locales PGSSE et résultats des analyses d’eau des réseaux d’adduction d’eau potable produit par le laboratoire de l’université Assane Seck ;
- Possibilité des recours des usagers auprès de la commune en cas de problème ou de non satisfaction du service de l’eau

En ce qui concerne les leçons tirées, ce projet pilote a surtout permis :

- D’animer un cadre de concertation sur l’eau et l’assainissement avec les acteurs au plan national sur les innovations du projet et les défis du secteur ;
- De responsabiliser les élus locaux dans leur rôle de planification local à travers le PLHA ;
- De donner l’opportunité aux collectivités locales de lever des fonds d’investissement au plan local mais aussi par le biais de la coopération décentralisée ;
- De mesurer la capacité des élus à suivre les activités de l’exploitant ( ASUFOR) et de l’interpeller en cas de besoin ;
- De préparer les élus locaux dans le cadre global de la nouvelle réforme avec l’OFOR.

#### Conclusions et Recommendations

Les activités de bonne gouvernance dans le service public de l’eau réalisées par l’ONG ACRA dans le cadre du partenariat entre la CUC et les Collectivités Locales de l’Arrondissement de Tenghory dans la région de Ziguinchor , représentent une expérience pilote qui essaie de valoriser les espaces donnés par le cadre de loi aux acteurs locaux pour stimuler l’émergence d’organismes démocratiques et d’envergure de régulation et contrôle du service de l’eau à travers un transfert de compétence par le biais de la coopération décentralisée (entre municipalités).

Le gouvernement du Sénégal a bénéficié d’un retour d’expériences sur les besoins en formation et les capacités existantes dans les municipalités en matière de régulation du service de l’eau.

L’expérience pilote de l’ONG ACRA et de la CUC pourra être améliorée dans le cadre d’un partenariat entre l’Etat central et les collectivités locales avec la réforme dite de nouvelle génération sous l’égide de l’OFOR.

En raison de la faiblesse des services techniques déconcentrés du ministère en charge de l’hydraulique , il faudra réfléchir sur la mise en place progressive de services techniques municipaux. Cela pourra contribuer à aider les collectivités à un meilleur suivi et des prises de décisions plus avisées.

#### Mentions

Union Européenne- Facilité eau no 2012 /256 424 Europaid 129510/C/ACT/multi

Commune de Cherbourg-en – Cotentin, France

Commune de Coubalan- Sénégal

Commune de Niamone - Sénégal

## MAPPING AND MONITORING

### Monitoring Systems

Commune de Ouonck- Sénégal

Commune de Tenghory- Sénégal

### Références

JC Magalbaes et al. (2012) « Renforcer la gestion communautaire de l'eau en Afrique: un modèle de partenariat décentralisé multiple au Sénégal » Pour plus de détails voir

<https://www.tni.org/en/article/strengthening-community-water-management-africa>

## MAPPING AND MONITORING

### Monitoring Systems

# The “Rural Water Supply and Sanitation Information System” (SIASAR) – Addressing Sustainability Gaps Through Visual Data in Latin America

Type: Long Paper

Authors: Antonio Rodriguez, Lilian Pena P. Weiss - *The World Bank, Washington DC, United States*

## Abstract

Understanding the various factors that drive sustainability, systematically collecting and updating data, and making it open and available to water and sanitation sector institutions at the national and local levels is helping Latin American countries trigger sector policies, planning processes and undertake concrete actions to address existing sustainability gaps. This paper presents preliminary findings of the data gathered through the Rural Water Supply and Sanitation Information System (SIASAR) from over 23,000 rural communities across eight Latin American countries. It further describes how countries are putting these data to work in their policy making and planning processes to improve the sustainability of rural water and sanitation services, and provides an overview of the initiative going forward.

## Introduction

One of the main challenges faced by the rural water supply and sanitation (RWSS) sector in the Latin America and the Caribbean region is the poor quality of service delivery as well as its limited sustainability over time. Water and sanitation services lay at the root of many other development challenges as they impact public health, education, household income, and the environment.

Today, 21 out of the 33 million people without access to an improved drinking water source in the Latin America and the Caribbean region live in rural areas ([JMP LAC Update 2015](#)). While a number of studies show the limited capacity of rural communities to operate and maintain the water systems, which often results in their collapse, RWSS investments continue to focus on building infrastructure, undervaluing the need for continuous support and reconstructing over time.<sup>128</sup> The lack of accurate, up- to-date and comprehensive data on the status of WSS service provision in the region compounds this issue, since little information is available for policy makers to identify needs and priorities, as well as to plan investment interventions as well as institutional strengthening measures. This has often results in investments that are biased toward new infrastructure, with little consideration for the costs of long-term operation and maintenance, the quality and coverage of the water service, or the capacity of local or municipal service providers to deliver water and sanitation services in a sustainable manner.

Central America encompasses a set of low to middle income countries with a total population of 44 million people. Some 42 percent of the population lives in rural areas, where there are some 50,000 rural communities. Official data show WSS service coverage in rural communities ticking upward over time, despite a persistent lag between urban areas and today some 84 percent of rural Central Americans have access to an improved water source. Existing coverage data, however, do not tell the entire story. Many residents who are purportedly covered by WSS services still lack reliable access to water that is safe to drink. An even greater proportion lives in areas with deficient sanitation that endangers public health and damages ecosystems. National figures do not capture the current status of WSS systems in rural communities, though a significant but previously unmeasured number of these systems are not operated in a sustainable manner and require outside assistance to maintain or regain working status

## Sector Structure

<sup>128</sup> For the purposes of this report, a rural community refers to a human settlement with up to 1,000 inhabitants.

## MAPPING AND MONITORING

### Monitoring Systems

In rural areas in Latin America, similar to many other developing regions, community management predominates the water and sanitation sector. The model varies in degree from one country to another, though in general a community-managed WSS service provider are tasked with two key functions for WSS infrastructure: (i) Management (registration of the CWB, tariff setting, billing, etc) (ii) Operation (day to day work of running, cleaning, and maintaining treatment plants). Successfully carrying out this dual role can be a challenge for some service provider staff—many are volunteers with limited training in the operation and management of WSS systems, and, in many cases, limited formal education. In light of this challenging environment, technical assistance seeks to support the community management of WSS services and the providers that deliver them.

### Technical Assistance

Technical assistance, as defined by McMahon, entails “the transfer or adaptation of ideas, knowledge, practices, technologies, or skills to foster economic development.”<sup>129</sup> In the context of the WSS sector at the community service provider level, technical assistance is considered to be external to the service provider and generally takes one of two forms: (i) Capacity building: formal or informal coaching, training, study tours, or other activities that strengthen the ability of an individual or institution to carry out its designated functions (for instance, leadership or accounting training that service provider staff will apply on an on-going basis, or maintenance training for a plan operator); or (ii) On-call support: tools, knowledge, and knowhow to address a discrete issue (for instance, drawing up legal documents, promoting a handwashing campaign, or fixing a broken pump). In many instances these are complimentary and mutually reinforcing. For the purposes of this report, the SIASAR initiative encompasses both variants—capacity building and on-call support—of technical assistance.

### Overview and Conceptual Model

#### Background

Quality and sustainability of WSS services are relatively limited in the rural areas of the Latin America and the Caribbean region, particularly in Central America. Public investment in the sector has been generally biased toward the construction of new infrastructure while little attention has been paid to the long-term operations and maintenance, or the capacity of local service providers to sustainably deliver water and sanitation services. Understanding the factors that compound these sustainability and quality gaps is critical for addressing them and improving the use of resources in the rural WSS sector through better and more efficient priority setting, policy development, project planning, budget allocation and technical assistance provision. The need for a comprehensive platform for having reliable and updated information for managing the rural WSS sector had been expressed by a number of countries, donors and water institutions in the region.

In 2011, the governments of Nicaragua, Honduras and Panama, with support from the World Bank, started developing the “Rural Water Supply and Sanitation Information System” (SIASAR), an ICT-based monitoring and decision-making system aimed to strengthen the knowledge base of the rural WSS sector and make this critical information accessible for policy makers, national and local planners, and sector practitioners. This effort ultimately intends to build an agenda for sustainability while putting rural communities on the map so they are considered in planning processes and able to access the outside resources they need to deliver sustainable WSS services.

Since the system was launched in 2011, SIASAR has been developed collaboratively, based on the work of local officials and experts from participating countries and on the technical knowledge and scalability support from sector partners including the Swiss Agency for Development and Cooperation, the Inter-American Development Bank (IDB), the Spanish Agency for International Development Cooperation

---

<sup>129</sup> “Applying Economic Analysis to Technical Assistance Projects,” Gary McMahon, <http://elibrary.worldbank.org/doi/abs/10.1596/1813-9450-1749>.



## MAPPING AND MONITORING

### Monitoring Systems

(AECID), IRC Wash, United Nations Children’s Fund (UNICEF), and Water for People. All these actors have supported SIASAR through active participation, dissemination of results and commitment of funds for training and system maintenance.



Shortly after SIASAR was successfully piloted, other countries within and beyond Central America joined the initiative, starting with the Dominican Republic in early 2013. In April 2014, the Central American and Dominican Republic Forum for Potable Water and Sanitation (FOCARD-APS) formally adopted SIASAR as its regional information system for the rural WSS sector by signing a regional accord. The initiative then expanded to Costa Rica, the Mexican State of Oaxaca, and Peru in 2015. Based on the successful experiences and engagement through 2015, Bolivia, Colombia, Paraguay, and the State of Ceará in Northeast Brazil joined in early 2016, scaling knowledge from lower to middle income countries. Sector authorities in Central America were instrumental in providing knowhow to facilitate the smooth entry of new member countries. Further interest has been expressed by other countries in the region, such as Ecuador.

### Conceptual Model

Poor sustainability is not exclusively related to infrastructure, the capacity of service providers, hygienic or organizational habits, and the quality of the technical assistance provide, among other factors also play a critical role in the sustainability of water and sanitation services, making the monitoring of all these variables essential for this complex decision-making process.

This idea led countries to design an information system that could in the simplest way assess the quality of service delivery and sustainability (in addition to traditional issues as water coverage, infrastructure, etc.) allowing institutions to anticipate problems and improving efficiency in investments. This “sustainability diagnostic” requires the definition of a general index that integrates all elements involved in the sustainability of the service. These four elements of analysis corresponding to four key dimensions of sustainable service provision in rural area are Community, System, Service Provider and Technical Assistance Provider.

## MAPPING AND MONITORING

### Monitoring Systems



Data related to each element of analysis is collected in the field through specific questionnaires by the entity responsible of SIASAR in each country, and is then verified by municipal or national authorities before being published on the public web site. Based on data entered and validated, the system automatically generates indicators, reports, maps, and graphs that allow for the characterization of the actual WSS services as well as for decision-making.

Each SIASAR element of analysis provides several indicators, classified in six categories, according to important issues in the rural water and sanitation services: Water Service Level, Community Sanitation and Hygiene Level, State of Infrastructure, Service Provision, Technical Assistance Provision and Schools and Health Centres. Combination among those indicators has as result the IAS: Water, Sanitation and Hygiene Index.

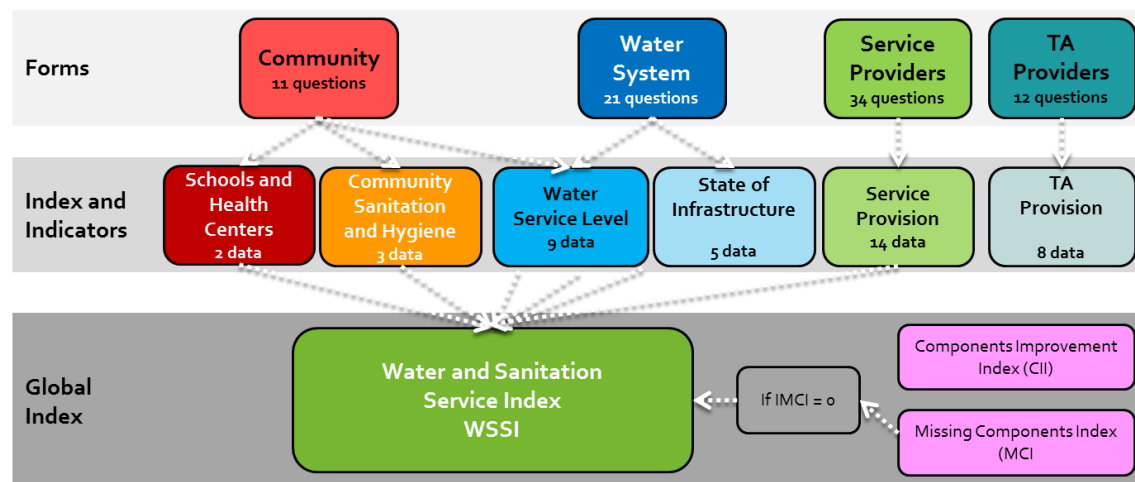

Finally, sustainability is evaluated in a four level metric, “the sustainability metric”, applied over all SIASAR elements or index. These levels, called ABCD qualifications, are determined when each indicator or index reaches a certain score:

- “A” corresponds to an optimum service level. This is the usual score in new infrastructures or services, and is the appropriate level for population and it should be maintained.
- “B” corresponds to an acceptable level of performance but there are some issues with certain problems. The service requires attention but problems can be solved by the community.

## MAPPING AND MONITORING

### Monitoring Systems

- “C” means an inadequate operational level that must be corrected, or rehabilitated. In this case, the community needs external support in order to solve the problem.
- “D” is the worst level and in this case the service does not exist or is offline and needs full recovery. The community needs external financial and technical support. This level is undesirable.

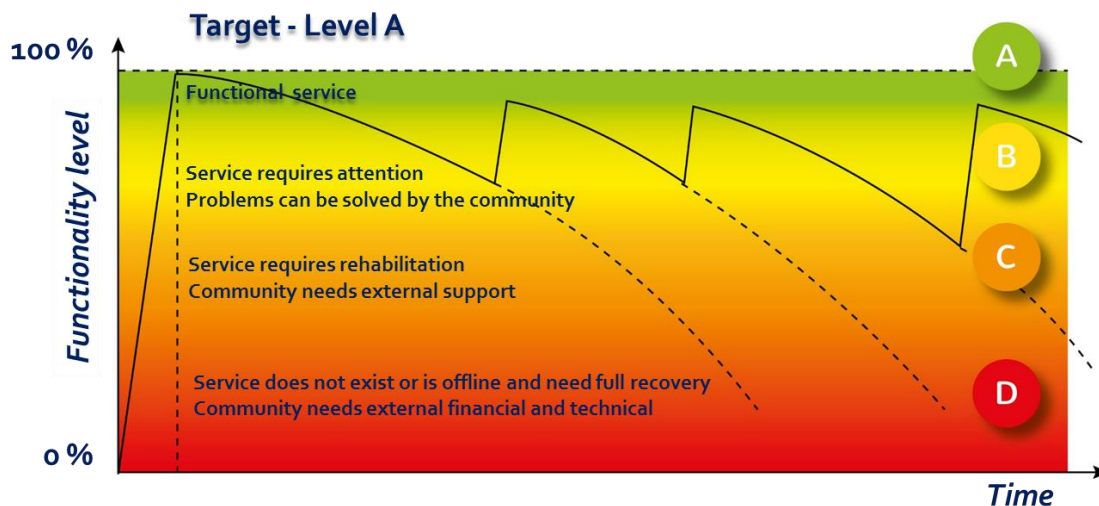

#### Box: Example of the Consequences of a System in Disrepair

A WSS system has been installed in rural community using local, national, or donor funds. The system is based on groundwater extraction: a pump lifts water out of the ground, transfers it to a filtration system, and eventually to a tank before it is distributed to homes. A backflow prevention valve has been installed between the pump and the aquifer to ensure that the flow of water does not reverse and push water the wrong way through the pump, which would damage the motor.

- **Level “A”:** The system functioning as intended.
- **Level “B”:** The valve begins to leak and water occasionally flows toward the pump. Nevertheless, local technicians are familiar with how the value works, have necessary tools and spare parts on hand, and are able to fix the valve before damage is done to the pump.
- **Level “C”:** The valve leak intensifies and reverse water flows begin to damage the pump. Outside technical assistance providers are able to support the community with tools, spare parts, and knowhow to fix the valve and ensure that the pump continues to work properly.
- **Level “D”:** The valve has broken completely, unleashing a flow of water backwards into the pump that ultimately causes the motor to burn out. The pump can no longer bring groundwater to the surface and the community is left without drinking water service. The pump must be replaced at great cost in order to restore drinking water service to the community.

### Data Collection and Analytics—what are the data telling us for far?

#### Data Collected to Date

SIASAR is currently implemented in eight Latin America countries and states, including Costa Rica, Dominican Republic, Honduras, Nicaragua, Panama, Peru, the State of Ceará in northeast Brazil, and the southern Mexican State of Oaxaca, where it is supported by more than 200 national and municipal partner institutions. There are over 23,000 rural communities entered in the system, covering approximately 19,000 systems across 17,000 service providers, as detailed in

Table 18. SIASAR coverage data reaches approximately 30 percent of targeted rural communities, amounting to 54 percent of the rural population of the member countries and states, or some 11 million people. Data collection remains underway and the 2016 target is to reach a total of 45,000 communities. Several interesting trends have emerges from the initial analysis of the data gathered to date.

## MAPPING AND MONITORING

### Monitoring Systems

Table 18. Data Collection – September 2016

Country	Validated communities	Country target	Percentage of progress to target	Estimated number of communities in the country
Costa Rica	5	5,000	0.10%	5,000
Dominican Republic	932	10,600	8.79%	10,600
Honduras	3,613	7,000	51.61%	28,000
Nicaragua	7,418	7,334	101.15%	7,334
Oaxaca	26	4,500	0.58%	10,306
Panama	1,037	4,598	22.55%	11,580
Peru	10,097	35,000	28.85%	85,000
<b>TOTAL</b>	<b>23,132</b>	<b>74,032</b>	<b>31.25%</b>	<b>157,820</b>

Source: Author’s calculations from SIASAR data.

### Descriptive Statistics and Initial Findings

Looking across data from all the communities registered in the system provides insights on two levels to complement existing coverage data: (i) a snapshot of the current status of WSS systems, providers, and communities; and (ii) factors that contribute positively or negatively to the sustainability of WSS services over time.

### WSS Systems

Data gathered through the SIASAR initiative offer a disconcerting picture of rural WSS systems: just 22 percent of the systems that have been built are classified as category “A” and thus fully functional and considered sustainable. A further 59 percent of systems have been assessed as category “B” systems—encompassing those in need of repairs within the community’s abilities. Conversely, some 18 percent of systems have been assessed as category “C” or “D,” suggesting that the system is on the verge of failure or is completely offline, and repairs are beyond the community’s abilities. The corresponding maps show us where systems are failing and where they are performing well, and point to spatial trends that inform policy making.

## MAPPING AND MONITORING

### Monitoring Systems

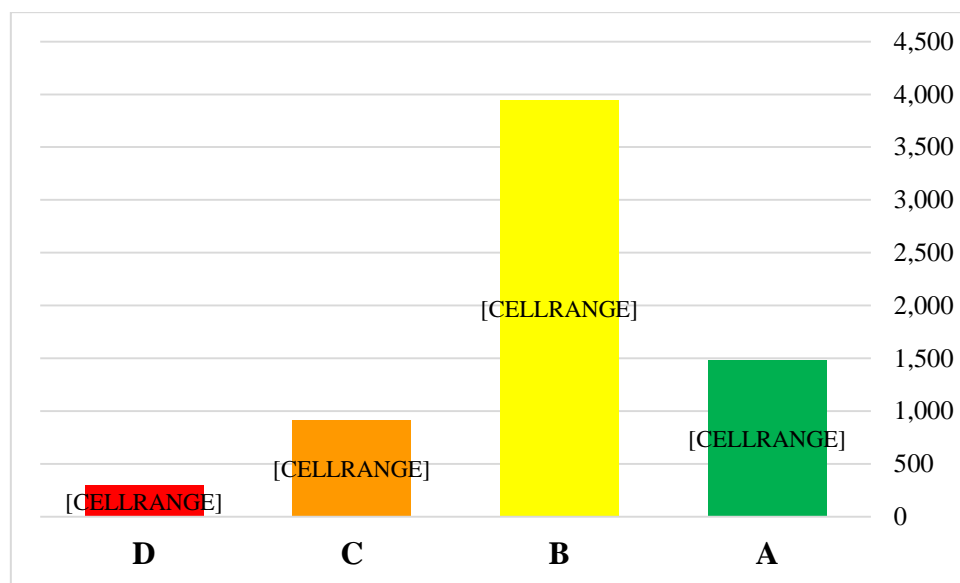

Figure 59. Systems by Sustainability Index  
 Source: Author's calculations from SIASAR data.

These figures bring with the headline figures for access to drinking water services into perspective. Coverage data reported in the [JMP LAC Update 2015](#) figures indicate that approximately 84 percent of rural residents in SIASAR countries have access to an improved water source. Of that 84 percent, however, SIASAR data indicate that only 45 percent of the systems they rely on deliver sustainable services. Thus, without effective maintenance, technical assistance, and financing, the gains made to expand WSS service coverage are at stake.

### Service Providers

Meanwhile, Figure 60 indicates that only 7 percent of service providers are in the “A” bracket, while 44 percent face issues that they can resolve on their own, landing them in category “B.” On the other hand nearly 60 percent of service providers have been assessed to need outside technical assistance or financial support. 11 percent of rural communities lack a service provider, those in category “D,” and 37 percent have a service provider face problems that exceed their capacities. Taken together with the data above on WSS systems, this suggests that there is not only a need for technical assistance for the maintenance and upkeep of systems, but, moreover, there a need exists to provide support to service providers to ensure that they can sustainability manage those existing systems.

## MAPPING AND MONITORING

### Monitoring Systems

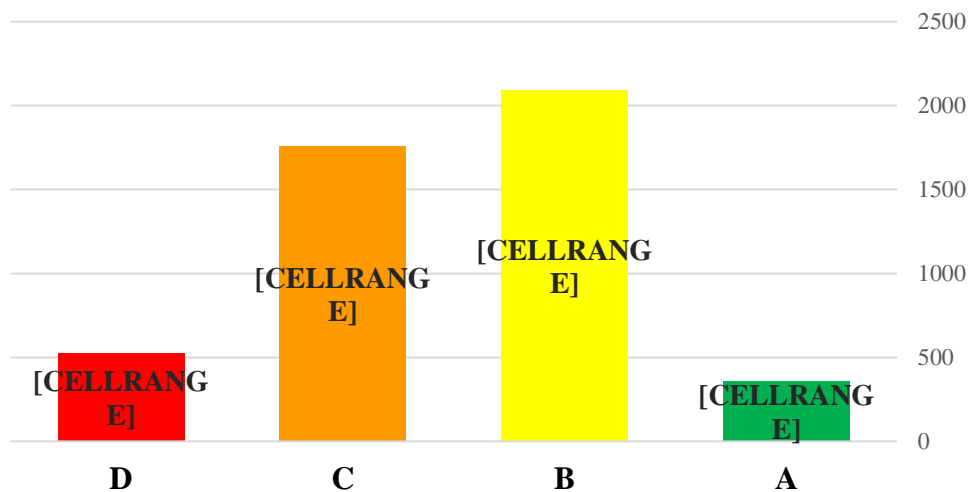

Figure 60. Service Providers by Sustainability Classification  
 Source: Author’s calculations from SIASAR data.

### Communities

Then looking at the community level index, which aggregates indicators from the system and service provider level, we observe a similarity of the community level classification distribution with that of service providers. Only 8 percent of communities have achieved a classification of “A” as shown in Figure 61. Fully 60 percent of communities fall in categories “C” or “D,” suggesting a relationship between the sustainability of the service providers and of the WSS service they are tasked with delivering—stronger service providers deliver more sustainable service.

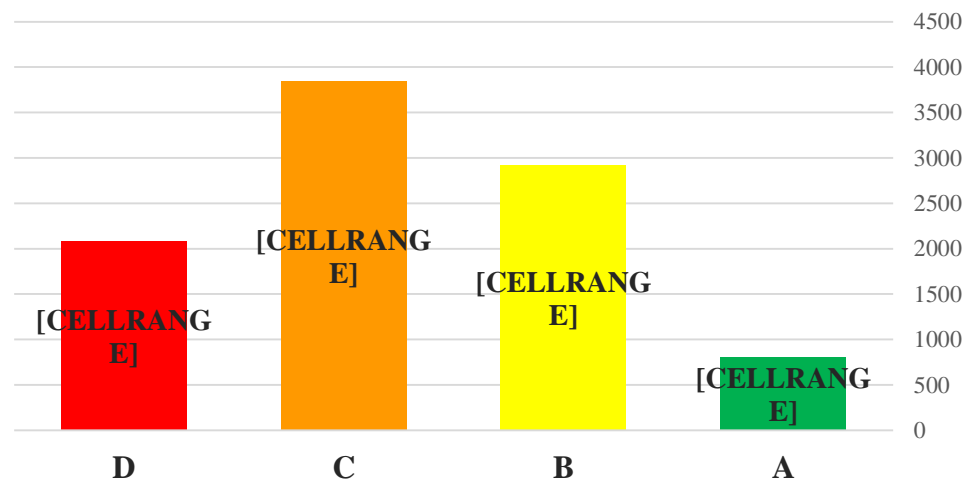

Figure 61. Communities by Sustainability Classification  
 Source: Author’s calculations from SIASAR data.

### Leveraging SIASAR Data for Sustainable Service Provision

Digging deeper into the single and cross-country data, factors that contribute to sustainability of WSS systems have begun to emerge and inform the policy making process. This section presents a series of findings from analysis undertaken by the SIASAR team. The open source database enables citizens, policy makers, researchers and academics, the media, NGOs, and others to build custom analytical work and in doing so expand the knowledge base.

## MAPPING AND MONITORING

### Monitoring Systems

#### Gender

Female participation in the administration of public services is thought to improve service quality. Data in the SIASAR system allows us to begin to test this hypothesis in the WSS service context.<sup>130</sup> At this point we cannot state that having women participating in community WSS service provider administrative boards guarantees service sustainability. Data from the SIASAR system indicate no substantial difference in sustainability between service providers with a male or a female president. Nevertheless, Figure 62 shows a positive correlation between the number of women on the board and service sustainability: Category “A” service providers have higher percentages of women board members. In sum, greater female participation in water board management appears to translate to more sustainable service. Further analytical work is underway to better understand how the different roles of female board members factor into sustainability.

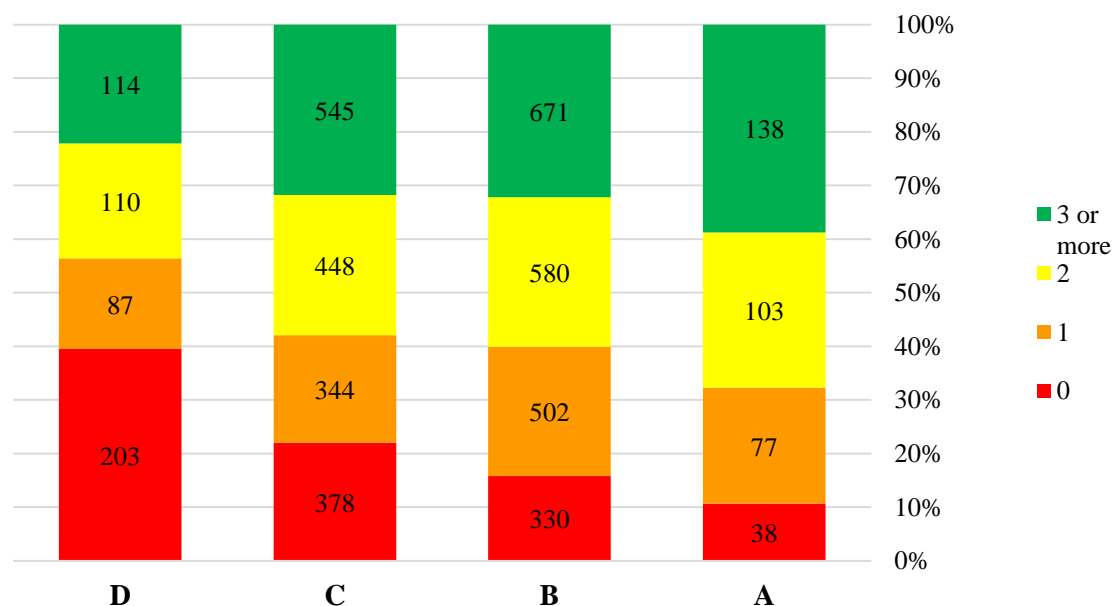

Figure 62. Service Provider Sustainability and Female Participation  
 Source: Author’s calculations from SIASAR data.

#### Legal Status

Attaining and maintaining legal status—that is, a formal registration with relevant local or national authorities in accordance with the norms and requirements of the jurisdiction—can improve a service provider’s ability to access funding that could be used for capital investments needed to expand service coverage or ability to establish partnerships with other institutions including NGOs or donors. Similarly, legal status can facilitate access to technical assistance. The benefits deriving from legal status should translate to more sustainable service provision.

Indeed, Figure 63 shows a positive correlation between the service provider classification and their legal status: legalized service providers tend to have higher sustainability scores. SIASAR data also highlight that the majority of service providers lack legal status. In many cases, the bureaucratic process of attaining legal status can be complex and many service providers lack the resources and specialized skills to complete the requisite paperwork on their own. Governments or donors can thus use the data and maps in the SIASAR system to better target specific technical assistance needed, often in the form of consulting or legal services, to help service providers overcome procedural barriers to attaining legal status.

<sup>130</sup> See, for instance, “Impact of women’s participation and leadership on outcomes,” Rosa Linda T. Miranda, [http://www.un.org/womenwatch/daw/egm/eql-men/docs/EP.7\\_rev.pdf](http://www.un.org/womenwatch/daw/egm/eql-men/docs/EP.7_rev.pdf).

## MAPPING AND MONITORING

### Monitoring Systems

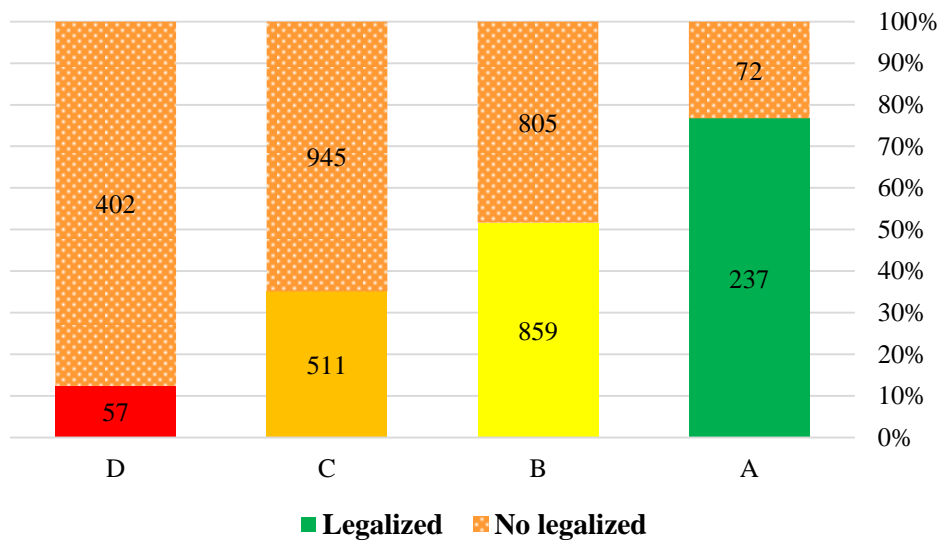

Figure 63. Service Provider Sustainability by Legal Status  
 Source: Author’s calculations from SIASAR data.

Alternatively, legal status can serve as a proxy for management and organization development at a community WSS service provider. The process involving in attaining legal status—including making management and accounting arrangements—requires service providers to ensure that the requisite management practices are in place. Thus, attaining legal status can catalyze a service provider to establish such mechanisms. At the same time, by reaching legal status, a service provider has demonstrated that it has a basic structure in place for sustainable service provision.

### Effectives of Technical Assistance Provision

Governments, donors, NGOs, and others have provided technical assistance in the WSS sector for decades and coverage and quality indicator suggest that much room for improvement remains. SIASAR data can serve as a tool to identify the effectiveness of technical service provision. Figure 64 measures communities that were visited by a technical assistance provider and that later moved from category “C” to categories “A” or “B.” This is intended to begin to encompass the effectiveness of the decision of what type of provider to send to a community (e.g., a social specialist to promote handwashing, a lawyer to process paperwork, or a mechanic to fix a pump) In the case depicted below, from Nicaragua, less than 30 percent of technical assistance provider visits resulted in an improvement in the community’s category in SIASAR. This reiterates not only the need for routine technical assistance, but also suggests that more work remains to be done to get communities the right kinds of targeted support at the times they need it most.



## MAPPING AND MONITORING

### Monitoring Systems

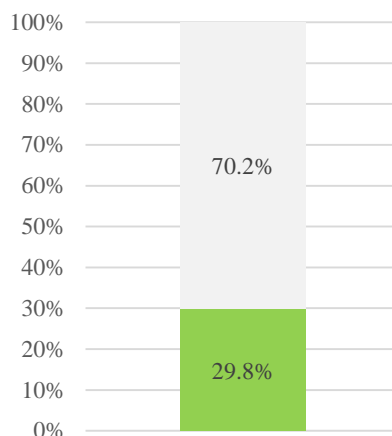

Figure 64. Communities Effectively Supported by a Technical Assistance Provider in Nicaragua  
 Source: Author’s calculations from 2015 Nicaragua SLASAR data.

### Indigenous Communities

WSS coverage data across Latin America show marked differences in access to services across ethnic groups, with indigenous and Afro-descendent communities often exhibiting the lowest levels of coverage in their respective countries. The Government of Peru has sought to go beyond coverage statistics to better understand the drivers WSS service provision in indigenous communities (Peru boasts one of the largest concentrations of indigenous peoples in the Americas). To that end, it has disaggregated SIASAR community level data by language to compare Spanish and Quechua speaking communities (a language native to the Andes mountains). Quechua-speaking communities fare better than their Spanish-speaking counterparts, as shown in Figure 65. It This finding speaks to the relevance of cultural factors to the sustainability of service provision. Nevertheless, both groups face important challenges as neither group contains any communities in category “A.”

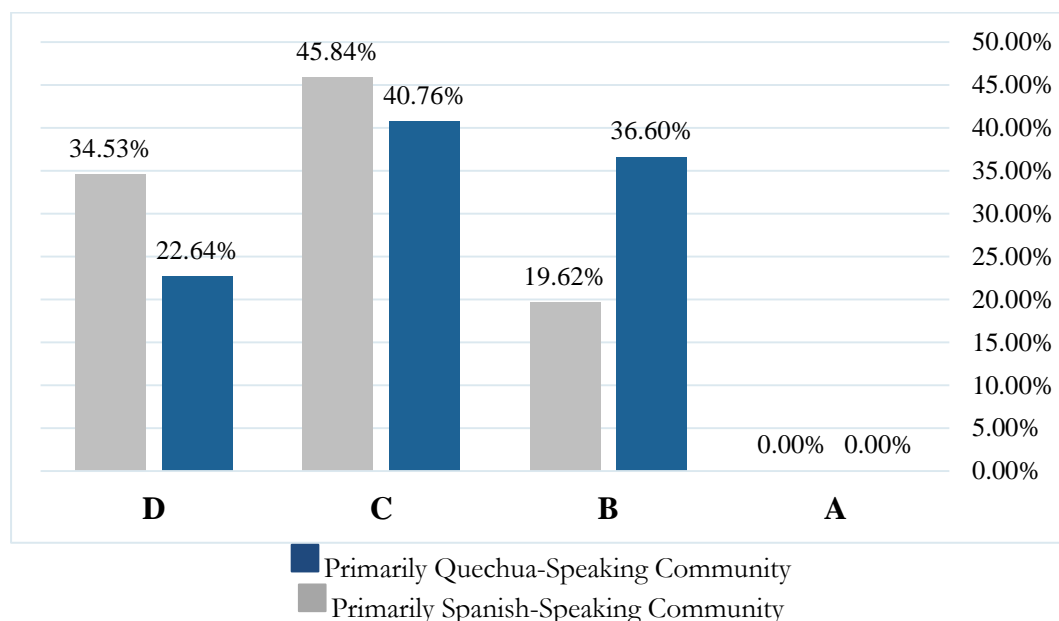

Figure 65. Classification of Communities by Primary Language in Peru  
 Source: Author’s calculations from SLASAR data.

### Handwashing

## MAPPING AND MONITORING

### Monitoring Systems

Data from the SIASAR system have been used to inform hygiene promotion initiatives as well. Data from indigenous communities in Panama drawn from the SIASAR system indicated a lack of handwashing practices, as Figure 66 shows, which could be attributed to a combination of a lack of infrastructure and cultural norms. Based on these findings, targeted technical assistance could help support hygiene practices in the communities where good practices are currently least prevalent. A deeper dive into the data could explore questions around whether infrastructure provision alone would be sufficient to increase handwashing behavior in indigenous communities.

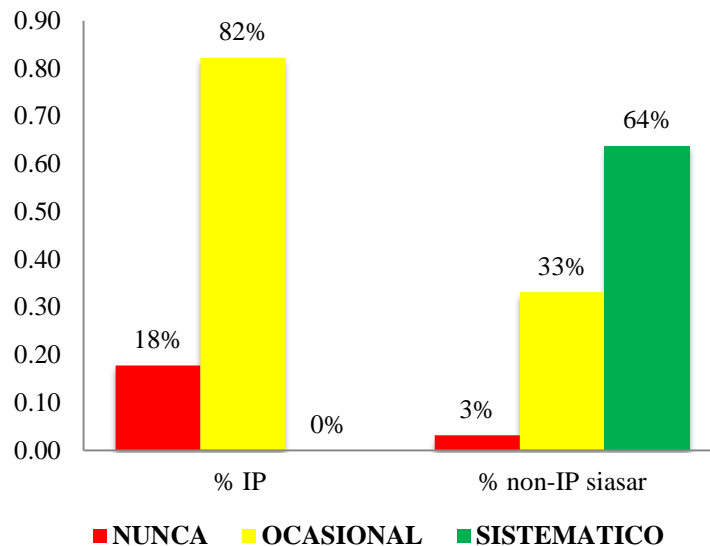
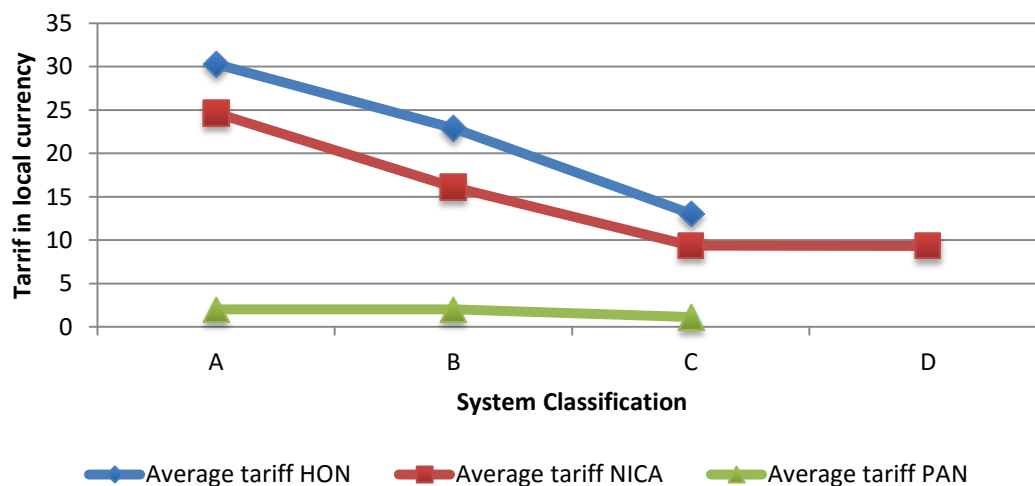

Figure 66. Handwashing in Rural Indigenous and Non-Indigenous Communities in Panama  
 Source: Author's calculations from SIASAR data.

### Tariffs and Sustainability

Charging tariffs to cover the operation and maintenance costs of a service is considered to be an important factor in ensuring system sustainability. This seems to be borne out in the SIASAR data, which indicate that in Panama, Nicaragua and Honduras, the amount charged declines with the WSS system classification. Communities that charge for services are more likely to have systems in classification “A.” In those communities with systems classified as “D,” there is often no charge for service whatsoever. This finding suggests that targeted technical assistance to support service providers in the development and application of a tariff structure that covers costs can help increase sustainability of the community’s WSS services.



## MAPPING AND MONITORING

### Monitoring Systems

Figure 67. Average Tariffs by System Classification in Honduras, Nicaragua, and Panama  
 Source: Author’s calculations from SIASAR data.

#### System Type

SIASAR data allow us to begin examining the relationship between different types of technologies and sustainability in a given context. Rural drinking water systems in Central America generally follow one of four schemes: (i) pumping, (ii) gravity, (iii) rainwater harvesting, or (iv) borehole with a hand pump. Figure 68 indicates that gravity fed systems have a higher percentage of systems in category “A” than pumping schemes, suggesting that the relative complexity added by pumps reduces sustainability. This finding sheds light on the communities and systems that will most frequently be in need of technical assistance, and gathers data that can be analyzed to the inform the types of systems to be built going forward with a interest in constructing infrastructure that is appropriate to local conditions.

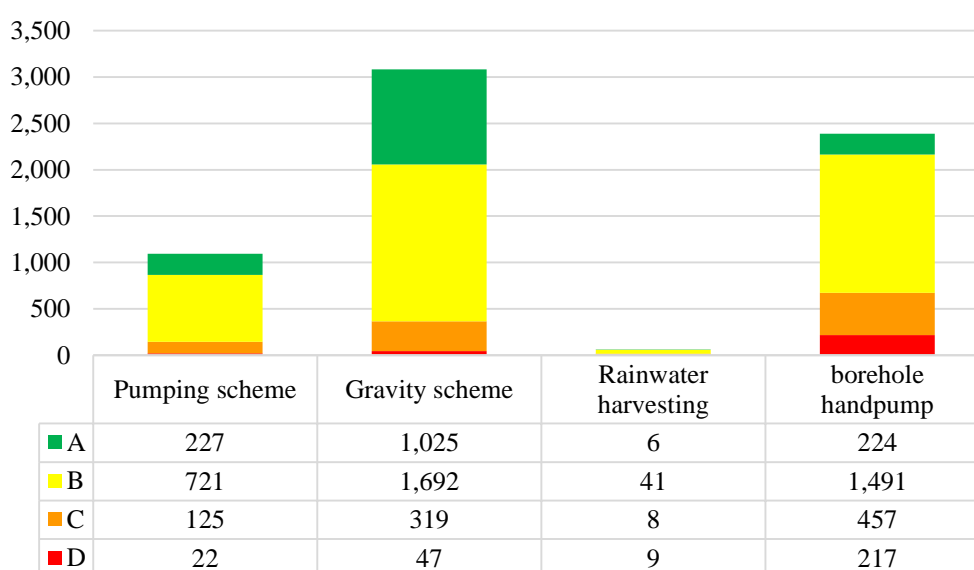

Figure 68. Drinking Water Systems by Type of Technology Used  
 Source: Author’s calculations from SIASAR data.

#### Embedding SIASAR Data in the Policy Making Process

As data collection grows, local and national policy makers have increasingly embedded SIASAR data in the policy making process. This section presents examples from Nicaragua, Honduras, the Dominican Republic, Panama, and Peru.

##### Nicaragua

In Nicaragua, where the implementation of SIASAR is most widespread, 64 rural water supply and sanitation municipal plans were developed using data from the system. These municipal plans have been a key tool for prioritizing the most vulnerable communities to receive investments and technical assistance. The selection criteria for municipal investments have been adjusted based on SIASAR data, and communities have started to receive targeted technical assistance based on system information. SIASAR classification (“A”, “B”, “C”, “D”) also served as the main source for developing the municipality eligibility and fund allocation criteria of the Sustainable Rural Water Supply and Sanitation Sector Program, for which municipalities where communities classified as “C” or “D” prevail were prioritized. Finally, SIASAR has been also used by sector institutions and development agencies to provide targeted technical assistance to local technicians on water and sanitation, focusing on those local water boards that rank last (“D” classification) in SIASAR.

##### Honduras

## MAPPING AND MONITORING

### Monitoring Systems

The government of Honduras has developed profiles on the status of rural WSS services in 28 municipalities based on SIASAR information to target technical assistance activities and inform the development of Municipal Development Plans. These municipal Development Plans are an instrument by which Honduran municipalities formally request the transfer of national funds for local investments. By incorporating data from the SIASAR system, municipalities are able to provide evidence and strengthen their case before the national government for capital to invest in WSS services. Additionally, SIASAR data is being used to develop so-called chlorine banks (“*Bancos de cloro*”) that make chlorine available to community water service providers in a particular region.

#### Dominican Republic

Dominican Republic has a number practice examples of using SIASAR data. In one instance, SIASAR data alerted authorities at INAPA (Dominican Republic national water utility) to the fact that pumps were offline in five rural communities, rendering their drinking water systems inoperable. Once aware of the situation, INAPA dispatched a mechanic to provide targeted technical assistance to fix the pumps, and the five communities’ drinking water systems have been brought back online. Additionally, three communities that were selected following SIASAR classification benefited from grant funds from the Turkish Cooperation and Coordination Agency. SIASAR data also helped reveal that water communities were facing important administrative weaknesses, which led INAPA to develop a program for regular training and supervision.

#### Panama

The Government of Panama is using SIASAR data to better target investments and technical assistance in indigenous communities. The National Indigenous People Development Plan guides the transfer of national resources from the Ministry of Governance to indigenous communities in Panama. Traditionally, the development of the Plan has been carried out by the longstanding Indigenous Roundtable. The government has used SIASAR to collect a representative sample of WSS services from 150 indigenous communities. It is in the process of analyzing this data to generate evidence about the status of service, investment needs, and TA requirements in these areas. This data will facilitate evidence-based dialogue at the Indigenous Roundtable.

#### Peru

Peru offers an instructive example of linking use of the SIASAR system to fiscal incentives at the municipal level. The country’s recently created Ministry of Development and Social Inclusion has been experimenting with various approaches to tie national transfers to municipal government performance. One incentive scheme entails transfers to municipalities based on municipal collection of data to be included in the SIASAR system. Within four months of the launch of the scheme, some 40,000 communities collected data for inclusion in the SIASAR system. At this time data is still being validated and cleaned before publication in the system, though once published this will represent the single largest concentration of communities to date. This innovative approach to data collection sidesteps the traditional model of sending consultants from community to community to gather data, resulting in a potentially significant reduction in costs per community. At the same time, the incentive structure places a greater burden for quality control on the national government to ensure that municipalities accurately report data.

### Looking Ahead

#### Operationalize the data for decision making

- The SIASAR initiative will continue to dive into the data to identify factors that contribute to the sustainability of rural WSS services. Similarly, engaging stakeholders—from local communities to service provider associations to NGOs to universities to hackathons—to conduct deep dives into the growing dataset will help to quantify factors that contribute to sustainable service and disseminate these findings to decision makers.

## MAPPING AND MONITORING

### Monitoring Systems

- In the near term, the SIASAR initiative intends to build a ‘technical assistance roadmap’ that indicates regular checkpoints, much in the way a new car comes with a maintenance schedule. The schedule could indicate what kinds of technical assistance would benefit a particular type of community, and at what intervals to dispatch the technical assistance provider. By following the technical assistance roadmap, service providers—and the governments and donors who support them—can reduce long-term costs by providing technical assistance systematically, rather than on an ad hoc basis.

### Increase community coverage data and maintain existing data up to date

- Putting communities on the map is proving to be an effective way to ensure that they are included in the planning process.
- Refine mechanisms to make the data relevant to policy makers, and in turn to encourage sector authorities to gather and maintain up-to-date data for use in decisions making processes to improve WSS service sustainability, particularly in the furthest afield communities.
- The Peruvian model of linking national government transfers to the collection and reporting of data for the SIASAR system creates an interesting incentive for local authorities to report data on WSS systems in their jurisdictions. This model could be taken a step further to ‘transfer for results.’ In this scheme, national governments could use the change in SIASAR indicators—for instance from category “C” to “A” as a trigger to allocate fiscal resources to a given municipality.
- Conversely, it is instructive to recognize where data collection has yet to meet expectations. The Mexican state of Oaxaca joined the SIASAR initiative in 2015 as part of a World Bank supported water sector strengthening program. The Government of Oaxaca envisioned including data from some 4,500 communities in the system. As of mid 2016, however, only 16 communities in Oaxaca have been reported in the SIASAR system. The World Bank program was changed at the request of the Government of Mexico, and the shift in priorities deemphasized data collection in rural areas. Once incentives to report data in the SIASAR system were lessened, data collection ground to a stop. This example highlights the importance of building and maintaining active monitoring of rural WSS systems in the local and national framework.

### Refine the model to best capture factors that contribute to sustainable WSS services

- The SIASAR initiative can help governments monitor progress toward achieving the United Nation’s 2030 Sustainable Development Goals (SDGs). To that end, there is an ongoing review of the SIASAR conceptual model to ensure that it is aligned with the monitoring framework for Goal 6: Ensure access to water and sanitation for all.
- SIASAR can grow into a tool to help rural communities adapt their WSS systems to increasing water variability brought about by climate change. Data could be incorporated in the SIASAR system to provide a visual representation of the spatial alignment of communities and the water they rely on.
- Little is known about the quality of water provided in rural areas. As modeling work progresses to better assess water quality, this data could be incorporated in the SIASAR system. Similarly, work is underway to link household and community level data, especially in the field of sanitation.

## MAPPING AND MONITORING

### Water Point Mapping

#### 3.5.2 Water Point Mapping

---

## Water Point Mapping in Tanzania: Making the voices of data collectors audible

---

Yola Georgiadou<sup>1</sup>, Jeroen Verplanke<sup>1</sup>, Juma Hemed Lungo<sup>2</sup>, Mercy Mbise<sup>2</sup>

(1) University Twente, The Netherlands

(2) University Dar es Salaam, Tanzania

### Abstract

Any attempt to develop mobile-phone based platforms that allow citizens themselves to report data on near-by rural water points and update the Water Point Mapping System (WPMS) baseline in Tanzania depends on an understanding of reporting practices of water users or their representatives within the local context. The aim of this paper is to describe such reporting practices to official data collectors during the nation-wide baseline data collection for the WPMS project (May 2011 to April 2013). We draw on field-work for a five-year action research project (2012-2017) titled [Sensors, Empowerment and Accountability in Tanzania \(SEMA\)](#), and funded by NWO-WOTRO Science for Global Development. Our conclusion is that working with the grain of actual information flows between local institutions may be a clumsy solution to rural water services, but it makes elegant failures less probable.

### Introduction

Several studies have compared mobile phone-based ICT platforms for improving water supply in the past few years. Welle et al. (2016) conducted the most recent cross-national comparison, which included eight such platforms, in three continents. Some rely on crowdsourcing—water users or their institutional representatives reporting water service failures. Others rely on either the government provider or NGOs collecting data regularly. These authors saw three related essential building blocks to achieving water service sustainability: (1) successful reporting, (2) successful report processing, and (3) successful service improvements through water scheme repairs. Obviously, steps (2) and (3) are contingent on the success of the first step—the successful reporting of the status of a water point, which is the focus of this paper.

Some authors attribute unsuccessful reporting to citizens’ distrust in government (McCall, Martinez and Verplanke 2013) or to the apathy of rural citizens (Daraja 2012). Others attribute the failure to a culture that cannot yet cope with the principle of documentation (Rottenburg 2009), a view frequently echoed in unpublished reports of consultants, who complain that “*there is no monitoring culture*” in the rural water supply sector. But while distrust, apathy or a lack of a monitoring culture may be plausible explanations of unsuccessful reporting, it is not clear how their opposites (trust, citizen engagement and a flourishing monitoring culture) can be created *in a specific context* except by stating the obvious: people will report failures if water officials are responsive to these reports and repair the water points.

One of the eight platforms evaluated by Welle et al (2016) was the human sensor web, implemented in 2010 in Zanzibar by University Twente, the Zanzibar Water Authority, a local mobile telephone company and a local internet service provider. Anyone could report the status of a water point, ‘no water’ or ‘bad water’, by sending a coded SMS to the database. Eventually, few people successfully reported and the human sensor web failed to provide continuous data on the quality of service provision in Zanzibar. Since 2012, the University of Dar es Salaam in cooperation with the University Twente are working on a new mobile phone-based platform, called SEMA, which means ‘tell me’ in Kiswahili. Currently, the SEMA software comprises an Unstructured Supplementary Service Data (USSD) client for standard mobile phones, and an Android client for smart mobile phones. Water users or Community Owned Water Supply Organization (COWSO) leaders with mobile phones may use it in rural Tanzania to report to local government authorities (LGAs) specific information about their water points. But this time, the

## MAPPING AND MONITORING

### Water Point Mapping

design and deployment of the new platform is part of a five year research project (2012-2017), called Sensors, Empowerment and Accountability in Tanzania (SEMA), and funded by NWO-WOTRO Science for Global Development. In our extensive fieldwork, we used the SEMA platform as a research tool that enabled us to collect meaningful information on the reporting behavior of citizens and the responsiveness of water officials to the reports. Additional funding by the Department for International Development (DFID), through the Human Development Innovation Fund (2015-2017), allowed us to scale the SEMA platform to four Tanzanian districts and to about 2000 rural water users and COWSO members, who are currently reporting regularly the status of rural water points in their villages.

In our research project, instead of engaging in cross-national comparisons of platforms which may hide patterns of local variation (Fox 2015), we focused on reporting practices within a single institutional context—rural water supply in Tanzania. Analytically, we distinguish between two related concepts: ‘*giving a report*’ and ‘*reporting*,’ or according to Pritchett (2013), ‘*giving an account*’ and ‘*accounting*.’ Empirically, we collected data on how the *same* individual, whether a rural Tanzanian water user, or a COWSO member, or a ward councilor or a district water official, is ‘giving a report’ of his actions and how she is ‘reporting’. Following Pritchett (2013), we define these two concepts thus: A **report** (or an account) on my duties as a rural Tanzanian water user, or as a COWSO member, or as a ward councilor or as a district water official is a justificatory narrative of my actions that I give to people whose opinion of me I value and whose esteem I seek. These people “*include myself, but also family and kinsmen, friends, co-workers, co-religionists, and people in my profession*” (p. 18). **Reporting** (or accounting) is that small part of my report which includes a few objective facts regarding my actions and communicates them to my hierarchical superior upon demand. As Pritchett argues, for my ‘reporting’ to be successful, it must converge with my ‘report’. The more my ‘report’ and my ‘reporting’ diverge, the more fictional are the ‘facts’ that I communicate in my reporting.

These two concepts allow us to reduce the problem of creating trust, or citizen engagement or a flourishing monitoring culture to the empirically-grounded problem of how to make ‘*giving a report*’ and ‘*reporting*’ by the *same* individual converge. During our fieldwork in rural Tanzania we collected ‘reports’ of water users, COWSO members, district water officials and ward councilors in focus group discussions, interviews and participant observation in the village market, on the street and in citizen assemblies as they interacted with each other. We found substantial evidence in rural Tanzania of a rich culture of ‘giving a report’, as defined above, and we documented it elsewhere (Nganyanyuka et al 2016a,b, c).

In this paper, we examine ‘reporting’ practices of village leaders to official collectors of rural water point data. The empirical setting is the nation-wide data collection for the Water Point Mapping System (WPMS), a massive and unprecedented project in Tanzania, and for all we know, in sub-Saharan Africa. The lessons learnt are essential when designing mobile-phone based platforms that allow water users or their representatives to act as data collectors and update the baseline data *themselves* (Georgiadou et al 2011, 2014).

### Description of the Case Study & Approach

The WPMS is an innovative web-based information system that aims to make rural water point data accessible to the public and easily updateable by local government authorities (LGAs). It provides in digital form the status of all rural water points in the country to inform national planning and budgeting. The blueprint for the WPMS was negotiated between the financier (World Bank) and the recipient (Ministry of Water) and carried out by the project implementer (a local company) in the period 2010-2013. Implementation included four activities: (1) nation-wide baseline data collection of all rural water point data, (2) development of the web-based Water Point Mapping System (WPMS), (3) provision of recommendations for the integration of WPMS into the monitoring systems and practices of LGAs, (4) support capacity building on the use and updating of the WPMS. Table 1 summarises the water point data collected during the nation-wide survey. At the time of writing, setting up a cost-effective updating platform still remains a significant challenge, while the WPMS baseline is constantly evolving.

## MAPPING AND MONITORING

### Water Point Mapping

	WPMS baseline data
<b>Baseline data describing the status at time T</b>	<b>Capturing the Water Point status</b> (1) Local time, (2) GPS time, (3) Functionality of Water Point (WP) in 7 STATUS classes, (4) Aggregation of STATUS in 2 classes, (5) Water quantity of WP, (6) Water Quality of WP, (7) Type of WP hardware problem, (8) Reason for hardware problem, (9) General comment, (10) Whether and when payment is received for water, (11) Amount of payment received for water use, (12) Whether a public meeting was held in the village about WP management
<b>Data describing the collective user</b>	<b>Collective User ID</b> (1) LGA name, (2) Ward name, (3) Village name, (4) Sub-village name, (5) Village population, (6) Population served by WP, (7) Village registration nr, (8) Village photo ID (9) Who is responsible for water scheme, (10) Who is responsible for WP
<b>Data describing the physical water point</b>	<b>Rural Water Point ID</b> (1) GPS location, (2) Water point code, (3) WP photo ID number, (4) Water scheme name, (5) Water permit issued for scheme from catchment, (6) Name of catchment, (7) WP local name, (8) Description of water source, (9) Type of extraction, (10) Type of WP technology, (11) Name of WP funder, (12) Name WP Installer, (13) Year of WP construction, (14) Year of WP breakdown, (15) Description of water source, (16) Type of extraction, (17) Type of WP technology

Table 1: WPMS Baseline data collected in the nation-wide survey (May 2011- April 2013)

At first sight, the idea of an ‘*evolving baseline*’ is puzzling. Even the total number of water points—the most basic aggregate fact of the baseline data—has been evolving since May 2013, as the baseline is being reviewed, verified, corrected, by the ministry and a series of consultants (Table 2).

WPMS Baseline	May 2013	August 2014	October 2014	September 2015
<b>Total number of water points</b>	75777	74250	58514	84945
<b>Online and official sources</b>	<a href="#">WSSR 2013 (GoT)</a>	MoW - <a href="#">WPM Technical Workshop</a>	<a href="#">Annual Review, 2015 DFID</a>	<a href="#">Annual Review, 2015 DFID</a>

Table 2: Evolution of the total number of water points in the WPMS baseline after May 2013

The WPMS baseline must represent the status of the WP infrastructure at time T0 and is a list of all mapped water points (e.g. 100,000 WPs) with their attributes. At a later time, T1, the list may feature 105,000 WPs either because 5,000 new WPs were constructed, or because 5,000 old (unmapped) WPs were “discovered.” But this is not a new baseline at time T1. It is the status of the WP infrastructure at time T1. Having a baseline at T0 allows us to make a credible claim at T1 that the WP infrastructure has improved or deteriorated during the period T1-T0.

#### What the approach is trying to achieve

First, there is a need to halt the “evolution” of the WPMS baseline and agree on what will constitute a single, authoritative baseline for all future comparisons. This matters because of the tight coupling between the WPMS and the Payment-by-Results (PbR) pilot proposed by DFID in Tanzania in 2013. The PbR pilot is a £78million incentive to central and local government to maintain and expand access to rural water points within each one of the 50 pilot districts. £1,500 will be paid for each functioning water point but not for new ones. Thus local government will have a strong incentive “*to maintain existing water points in a sustainable manner and to fix broken water points instead of simply building new ones [...] Payments will be*



## MAPPING AND MONITORING

### Water Point Mapping

*made upon an independent verification of results, building on the existing Water Point Mapping System.”* (Janus and Keijzer 2015, p. 12).

Second, there is a need to make audible the voices of actors—like data collectors—that are normally silenced in the literature of development cooperation. Data collectors have been central figures only in high literature so far, and then only as hapless victims of village bureaucrats. For instance *K*, the land surveyor and protagonist in Franz Kafka’s *The Castle* (1926) was lectured thus by the village mayor when he expressed his wish to collect data in the village: “*As you have noticed, Mr Land Surveyor, I knew all about this affair [...] But now that you have been kind enough to come and see me yourself, I have to tell you the whole, if unwelcome, truth. You have been engaged, you say, as a land surveyor, but unfortunately we don’t need a land surveyor. There wouldn’t be any work for you here at all. The boundary markings of our little farms are all established, everything has been duly recorded. Property hardly ever changes hands, and we settle any little arguments about the boundaries ourselves. So why would we need a land surveyor?*” (p.55). Silencing data collectors’ voices is unfortunate at a time when the so-called “crowd” is supposed to be the ultimate source of any online data and work, from tedious micro-tasks performed by large, paid crowds (e.g. Amazon Mechanical Turk) to developing common goods (e.g. Wikipedia), to reporting potholes to government (e.g. FixMyStreet).

#### How the work was undertaken – Four concepts

**Elementary data:** Ideally, baseline data collected in the field should be *elementary*. Elementary data are either facts or figures for which a consensus between the data collector and the villagers can be easily established on the ground, in the real world. Elementary *facts* have an indisputable referent in the field. Examples are: “*the users of this water point refer to it as Kwa Juma Popo*”, “*this water point is a shallow well*”. For villagers, the local name *Kwa Juma Popo* means that the water point is next to the house of Juma Popo, or next to his farm, or within his farm. Elementary *figures* are numbers that refer to a countable reality in the field. An example of an elementary figure could be “*the water quantity at local time T at this water point is the amount of time it takes to fill a 20-litre bucket as witnessed by the data collector and the villagers.*”

**Elementary administrative procedures:** A set of elementary data collected in the field constitutes a valid baseline for a country when *elementary administrative procedures* are in place to link the collected data with their administrative representations at the local government authority (LGA) office and the Ministry of Water. An example of such a procedure is the mapping between *Kwa Juma Popo* and a unique identifier generated by the National Bureau of Statistics, e.g. 05023043181WP50 meaning (05 – Region code, 02 – District code, 3043 – LGA code, 181 – Ward code, and WP50 – water point number). The elementary administrative procedure creates a solid link between the local name of the water point (*Kwa Juma Popo*), which has a meaning for the villagers, and its administrative representation—the unique water point identifier 05023043181WP50—at the LGA office. A water engineer at the local government authority (LGA) office or the ministry of water would experience the solid link between *Kwa Juma Popo* and 05023043181WP50 as two entries next to each other in a row of an excel sheet that contains all the elementary data of the water point.

**Transaction-intensiveness:** The collection of baseline data is a transaction-intensive activity. It requires a large number of interactions, always involving face-to-face contact, between the data collectors and informants: the local water technician, the village executive officer, the traditional village chief, members of the village water committee, individual villagers and other non-resident water users such as pastoralists. 70% per cent of the Tanzanian population of 44 million is settled in thousands of villages, and population increases by 1.2 million people annually, one of the fastest growth rates in the world (UNDP 2014). The country covers an area almost twice as large as France, variation in rainfall and water resources is considerable, and transportation is often slow, unreliable and costly. The daily schedule of a data collector can be excruciating. Data collection commences early in the morning and terminates at sunset. During the rainy season, reaching villages even with a four-wheel drive vehicle is impossible and a canoe or a motor bike must be used instead. Walking on foot for up to eight hours in order to reach a WP and collect data is common.

## MAPPING AND MONITORING

### Water Point Mapping

**Discretion:** The collection of baseline data is also a discretionary activity because the data collector must make decisions on the basis of information supplied by informants that “*is important but inherently imperfectly specified and incomplete, and entails extensive professional or informal context-specific knowledge*” (Prichett and Woolcock, 2004, p. 194). The data collector depends on the ward executive officer for village populations of villages and registration numbers. He depends on the village executive officer (VEO) to walk him to each existing water point. He depends on the village water technician, the water committee and water users for answers to questions such as the type of water extraction, the status (functional, non-functional, needs repair) of the water point, specific hardware problems and (seasonal) water quantity. Only water committee members, the technician and users may remember the year and technical reasons for breakdown as well as non-technical reasons (e.g. theft) for a non-functional pump. Finally, only water committee members and residents know which amount a citizen pays as service fee when he/she draws water.

### Main results - Capturing WPMS baseline data from villagers

The local company contracted by the Ministry of Water captured the rural water point data from May 2011 to April 2013. It trained data collectors in digital techniques of data capture, including GPS equipment, tablets, and digital cameras. Each data collector capturing a water point in a village had to position the water point with GPS coordinates, photograph it and inscribe on it the official code described earlier, using a special pen with indelible ink. The idea was to establish a *solid physical link* between the local name of the water point (e.g. *Kwa Juma Popo*) and its administrative representation—the unique water point identifier 05023043181WP50—at the LGA office. The data collector was accompanied by the district water engineer (DWE) or his representative. He depended on the local knowledge and willingness of village leaders to be interviewed and to provide him with a host of other data—functionality of the water point, the perceived quality and quantity of water, time of latest breakdown, name of original constructor, among many others (see Table 1) that would uniquely identify the condition and infrastructural history of each water point. Last but not least, the data collector depended on the willingness of village leaders (either indigenous local chiefs, or local appointees of the district government) to walk him to each water point. Our in-depth interviews with one of the data collectors (here referred to as M<sup>131</sup>) and the inspection of the May 2013 WP baseline revealed a number of issues, of which we list four:

**Only a few of the collected data were elementary** (e.g. “*the village name is Fukwe*”, “*the users of this water point refer to it as Kwa Juma Popo*”). Other data (e.g. the population served by the water point) were *aggregated* estimates either guessed or extracted from paper records often of dubious quality. Yet other data (e.g. water point functionality) were not only discretionary in terms of how the collector and the village leader perceive the water point status, but also fluctuating over time due to fluctuating official definitions of functionality, different methods to aggregate functionality, as well as due to changes of official names of administrative units during the period of data collection. The official ID—the string of digits and numbers derived from the administrative hierarchy region/district/ward/village/sub-village and an arbitrary integer—assigned to each water point by the data collector, was particularly vulnerable, as villages ended up in newly formed wards and districts with different names. As a result, the solid link between the ‘field’ and office representation of the WP was broken for those villages and wards.

**The WP database consumed itself from the inside**, a phenomenon called *autophagy*<sup>132</sup>. To capture the water point functionality in the field, the data collector assigned a ‘status’ to each water point by choosing one out of several predefined status categories of ‘functionality’. These categories ranged from ‘functional’ to ‘needs repair’, to ‘service interruptions for less than 3 months’ up to ‘more than six months’, and finally ‘non-functional’. During data processing the original ‘status’ was aggregated into a ‘status II’, by combing all service interruptions of more than three months into the category ‘non-functional.’ All water points that had less than 3 months of interruption or required simple repairs were

<sup>131</sup>We call the data collector *M* due to the eerie similarity of his experience to that of *K*, Franz Kafka’s land surveyor in *The Castle* (1926).

<sup>132</sup>Rottenburg (2009) defines *autophagy* (from the [Greek](#) *auto*, “self” and *phagein*, “to eat”) as the phenomenon in which paper lists, databases and maps consume each other (through inconsistency) and themselves from the inside (through invalidity) and attributes it to a culture “*that cannot yet cope with the principle of [bureaucratic] documentation.*” (p. 108).

## MAPPING AND MONITORING

### Water Point Mapping

labelled ‘functional’. Apparently, there was an informal agreement between the local water committees and the DWEs that “*small repairs usually take up to three months to fix*” and therefore labelling such water points as ‘non-functional’ was not expedient. However, when the first version of the rural WMS was published in 2013, the database was full of water points that were recorded more than three years earlier and no updates were made to see whether the points needing repair had been actually in the meantime. In order to correct for this, elementary data had to be consistently linked to the IDs inscribed on the water points. But the official ID changed when villages ended up in newly formed wards and districts with different names, and the written ID labels themselves disappeared. On top of this about 5% of the recorded water points in the rural WMS displayed inconsistencies with regards to their numbering (unique identifiers that were not unique) or location. This meant that many water points would be impossible to update, because it is impossible to link them to the database unless the full records are available to the village water committee and cooperation from the village leaders is guaranteed. All these records therefore technically became outdated and irreparable, consuming themselves from inside.

**Water points were occluded** and therefore not captured because of the outright refusal of the village leader to cooperate. We quote a characteristic example of a dialogue between our data collector and a village leader:

*“We arrived at the village in the evening and were immediately confronted by the village leader. He was a traditional chief elected by the villagers according to ancient traditions. To his question about the purpose of our visit I answered:*

*M: We come from the [national water authority] and want to map the water points in your village.*

*Village Chief: What is the benefit of your work for us?*

*M: All we want to do is take the inventory of the water points, because the government wants to construct water points in every village.*

*Village Chief: Others like you came here with the same stories in the past and they did nothing. Go away!*

*I explained that this time was different. And my proof was the DWE’s presence. Unfortunately this made things even worse.*

*Village Chief: What are you talking about? We have not seen a DWE here since the construction of the water well [many years ago]. The DWE is paid to help us and he and the government have abandoned us. I don’t believe you. Go away!”*

In other instances, M was met with (what he perceived as acts of) wilful *deception* by village leaders, for example: “*The village leaders [appointees of the district] often lied to me when I asked where the water points are. They reported having fewer water points than they actually did. They did not report water points that could be reached only by walking many hours. They also hoped that by lying about existing water points (especially those far away) I would construct more water points closer to them. Obviously, they over-estimated my powers. I am only a data collector.*”

**Beliefs in magic** were common in the western world from classical times to the enlightenment, especially in times of rapid change and urbanization, and are still widespread in Tanzania (Pew Research Centre 2010). Beliefs in magic and witchcraft should not be dismissed as irrational attitudes that need to be eradicated but as means for resolving conflicts and defining and affirming social boundaries in communities (Douglas 1970). We quote a characteristic excerpt from an interview with M, the data collector, on such beliefs in rural water supply: “*Some of the elders of the villagers (e.g. traditional chiefs) do not want their water point to be mapped and marked because they believe that once I map and mark the water point the water may disappear or dry up. In one village the leader walked us to the water point where several pastoralists were fetching water. I told the people that I wanted to take a picture of the water point. Some fled, and some hid their faces. I took the photo nevertheless, and when the time came to write the official ID of the water with the special pen they protested vehemently: ‘The water will disappear if you write on the water point.’*”

Early in 2014, DFID hired a consultant to formally assess whether the WPMS baseline was good enough for the Payment by Results pilot. The consultant discovered that the baseline data of May 2013 “*was far worse than the GoT and donors had expected. This was an unexpected challenge to both GoT improving delivery of functional water points, and GoT and DFID monitoring outcomes to make PbR payments.*” (DFID Annual Review, 2015). About 75% of the official IDs inscribed on the water points had disappeared, although the special pen inscription was designed to last. It is difficult to tell whether the inscriptions are worn off due to exposure to the sun and rain or whether they were intentionally removed after the data collector’s departure

## MAPPING AND MONITORING

### Water Point Mapping

to remove the magic spell. The consequence is the same. The physical link between the water point on the ground and the corresponding entry in the WPMS baseline has been severed. The consultant made the sensible recommendation to update the baseline with new rigorous procedures rather than to repeat the whole data collection from scratch. In August 2014, the World Bank and the Ministry of Water invited all stakeholders to a technical workshop in which “*technical people should have technical discussions, share our experiences in rural water management systems and agree on a way forward*” (senior ministry official). The baseline has been evolving ever since and setting up an updating platform remains a significant challenge.

In this section, we examined characteristic ‘reporting’ practices of village leaders to official collectors of rural water point data. The divergence between these ‘reporting’ practices and ‘reports’ (Nganyanyuka 2016b, c) can be explained by the long history of mutual by-passing of villagers and the state. On the one hand, the donors and the state have chronically by-passed local institutions and villagers in the shaping of rural water schemes (Therkildsen 1988). On the other hand, the peasants have persistently resisted being ‘captured’ by the state (Hyden 1980), ever since the Ujamaa period, which promised peasants ambitious rural water supply schemes if they resettled in new villages. The peasant ethic of mutuality and reciprocity eventually saved the peasants from the heaviest burdens of forced resettlement, which was eventually abandoned, while the water schemes rapidly deteriorated. The peasants' uncanny ability to opt out of resettlement via covert resistance (e.g. foot-dragging) and their tenacity in preserving their way of life prevailed. Their resilience to forceful state interventions “*comes as no surprise if one bears in mind that the institutional order in Tanzania and its colonial and postcolonial legacy never really demonstrated their superiority in providing justice and prosperity.*” (Rottenburg 2009, p. 141). The occlusion of water points, the (perceived) acts of deception and even the beliefs in magic in rural water supply may be seen under the light of a continuing covert peasant resistance to the state and its data collectors.

### Lessons learned

An adaptive approach is needed to design a mobile-phone based updating platform that “*goes with the grain*” (Kelsall 2008) of local culture. It should include: **(1)** mapping of the actual tasks and information flow between the LGA and rural citizens (see e.g. Figure 1), **(2)** clustering the tasks into major steps (e.g. detecting, reporting, diagnosing, mobilising funds, purchasing, fixing) and depending on whether these unfold outside or inside local (village and district) institutions, **(3)** classifying the micro tasks based on degrees of discretion and, finally, **(4)** digitising steps incrementally and based on the priorities in Table 3. See Nganyanyuka et al (2016b) for further details.

**Tasks outside the village and district institutions:** These are tasks in steps I (detecting), II (reporting), III (diagnosing the water point breakdown), V (purchasing spare parts) and VI (fixing) and have a mix of low and medium discretion. Tasks in steps I (detecting) and II (reporting) are low-discretion, and easily amenable to digitization, but only if a village official, willing to be assimilated in the hierarchical monitoring process, carries them out. Tasks in step III (diagnosis) require the physical presence of a skilled individual at the village and can be transformed by non-technological solutions e.g. by building the capacity of COWSOs to effectively monitor and repair broken water points without depending on the district council. Tasks in steps V and VI are amenable to digital transformation. Information about breakdowns and possible solutions that is available transparently and in a timely fashion may provide external market parties with the opportunity to stockpile spare parts efficiently and dispatch technicians to the right locations. A social enterprise could probably provide this service under a business model that would benefit a network of warehouses and technicians down to village level.

Table 3: Digitizing task and information flows (Nganyanyuka et al 2016b)

Steps	Low Discretion # tasks	Medium Discretion # tasks	High Discretion #tasks	Amenability to digital transformation	Priorities
I: Detection & reporting at village	2			High	1 <sup>st</sup> priority - Mobile phone based

## MAPPING AND MONITORING

### Water Point Mapping

II: Reporting to the district	1				updating platform – SEMA platform
III: Problem diagnosis		4		Medium	<b>2<sup>nd</sup> priority</b> - Social enterprise
V: Purchase of spare parts		2			
VI: Fixing	2	2			
IV-A: Village mobilizes funds by withdrawal	9	3	1	Low	<b>3<sup>rd</sup> priority</b> - Simplifying rules and proce- dures in collabora- tion with actors, then digitizing
IV-B: Village mobilizes funds by collecting contributions	11	2	3		
IV-C: Village mobilizes funds at district council	33	10	3		

**Tasks inside village and district institutions:** Tasks in step IV-A (mobilize funds at village level through withdrawing money from bank), IV-B (mobilize funds at village level through contributions), and IV-C (seek financial assistance from the district) include a mix of all three levels of discretion-low, medium and high. Medium discretion tasks in step IV-A, IV-B and IV-C include attendance to meetings, travelling to carry letters to the district council and withdrawing funds from the bank. High discretion tasks include approval of the COWSO steering committee to request funds from the DED or the district treasurer. All these tasks unfold within local (COWSO and village government) and district institutions and are infused with an incredible amount of rules and procedures, both formal and informal. While some of these procedures may appear to be absurdly complex to an outsider, they reflect a deeply embedded bureaucratic culture that should not be dislodged with technological means. Thus while non-discretionary tasks in step IV-A, IV-B and IV-C might seem to be easy candidates for digitization we strongly recommend to refrain from expediting them with technology, before new rules and procedures are deliberated upon and agreed by all concerned actors.

MAPPING AND MONITORING

Water Point Mapping

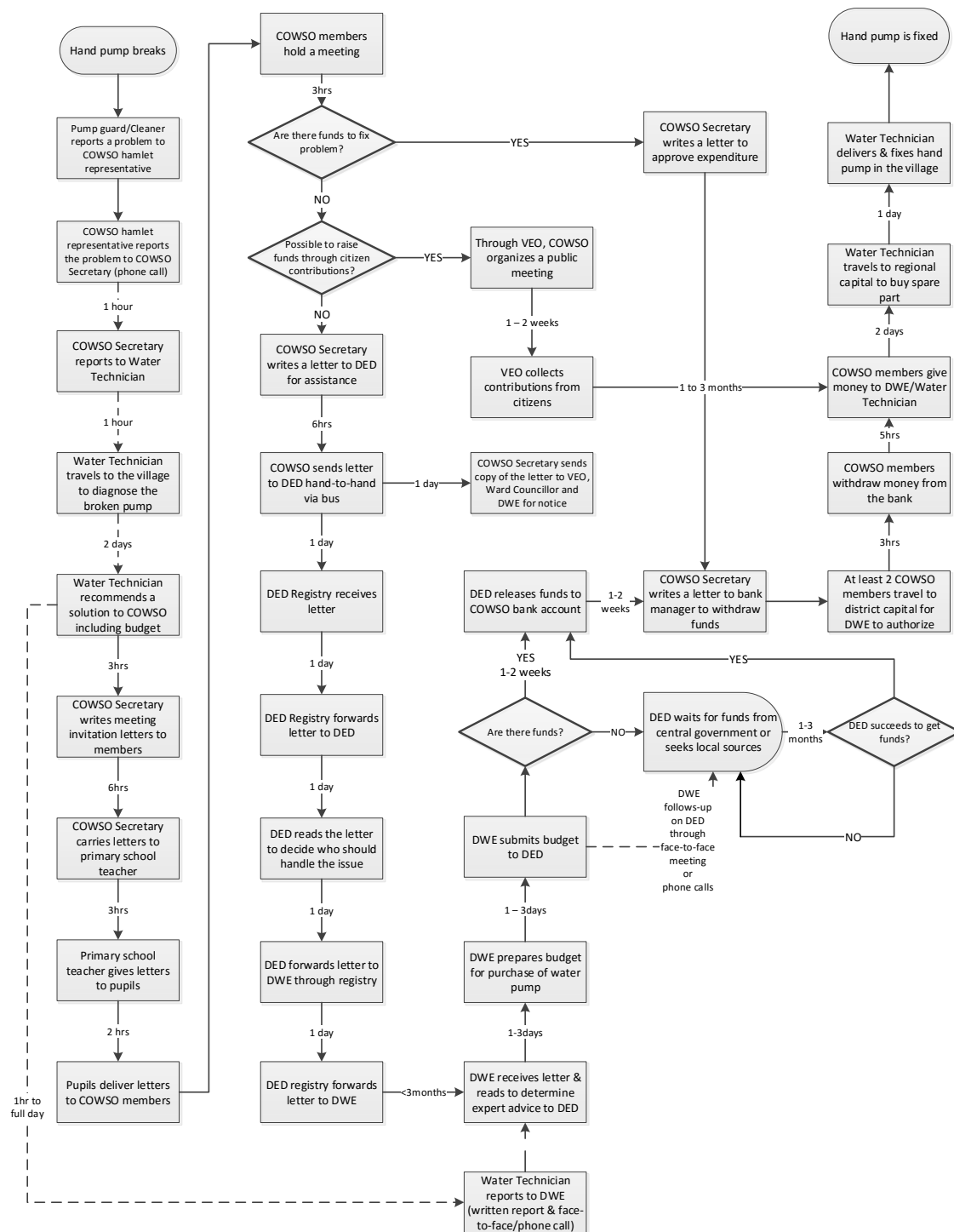

**Characters**

- Community Owned Water Supply Organisation (COWSO) Secretary
- District Executive Director (DED)
- Water Technician
- District Water Engineer (DWE)
- Teachers and Pupils
- Bank

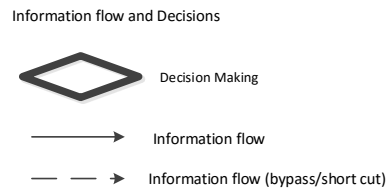

Figure 1: Typical task and information flow of the monitoring and repairing a rural water point - Nganyanyuka et al (2016b)

References

## MAPPING AND MONITORING

### Water Point Mapping

- Daraja (2012) Why did Maji Matone Fail? 3. Citizens Engagement, Risk and Apathy, *Daraja Blog*, <http://blog.daraja.org/2012/02/why-did-maji-matone-fail-3-citizens.html> (accessed 29 August 2016)
- Douglas, M. (1970) *Witchcraft Confessions and Accusations*, Tavistock. 387 pp.
- Fox, J. A. (2015) *Social Accountability: What Does the Evidence Really Say?* World Development Vol. 72, pp. 346–361, 2015
- Georgiadou, Y. et al. (2011) Sensors, empowerment and accountability : a digital earth view from East Africa. In: *International Journal of Digital Earth*, 4 (2011) 4 pp. 285-304.
- Georgiadou, Y., Lungo, J.H. and C. Richter (2014) Citizen sensors or extreme publics? Transparency and accountability interventions on the mobile geoweb. *International Journal of Digital Earth*, 7 (2014)7 pp. 516-533.
- Government of Tanzania (2013) [BIG RESULTS NOW! \(BRN\) Presentation to PER Annual Review Meeting](#), Julius Nyerere International Convention Centre, 4th October 2013
- Hyden, G. (1980) *Beyond Ujamaa in Tanzania: Underdevelopment and an uncaptured peasantry*. Heineman Educational Books Ltd. ISBN 0 435 96301 5
- Janus, H. and N. Keijzer (2015) *Big Results Now? Emerging Lessons from Results-Based Aid in Tanzania*. Discussion Paper / Deutsches Institut für Entwicklungspolitik, ISSN 1860-0441, Bonn
- Kafka, Franz (1926) *The Castle*. Oxford University Press, Oxford World's Classics. 318 pages
- Kelsall, Tim 2008 *Going with the grain of African Development?* Africa Power and Politics Programme (APPP), Overseas Development Institute, 111 Westminster Bridge Road, London SE1 7JD, UK
- McCall, M.K., Martínez, J.A. and J. Verplanke (2015) Shifting boundaries of volunteered geographic information systems and modalities : learning from PGIS. In: *ACME : an international e - journal for critical geographies*, 14 (2015)3 pp. 791-826.
- Nganyanyuka, K., J. Martinez, J.H. Lungo, Y. Georgiadou (2016a) If citizens protest, do water providers listen? Water woes in a Tanzanian town, Submitted to *Habitat International Journal*
- Nganyanyuka, K., J. Martinez, J.H. Lungo, J. Verplanke, Y. Georgiadou (2016b) Working with the grain: How amenable to digital transformation is the monitoring and repair of rural water points in Tanzania? Submitted to *ITID Journal*
- Nganyanyuka, K., J. Martinez, J.H. Lungo, J. Verplanke, M. Mbise, Y. Georgiadou (2016c) Formality and informality in rural water supply in Tanzania: Implications for mobile-phone based platforms? In preparation.
- Pritchett, L. and M. Woolcock (2004) Solutions When the Solution is the Problem: Arraying the Disarray in Development. *World Development* Vol. 32, No. 2, pp. 191–212
- Pew Research Centre (2010) *Tolerance and Tension: Islam and Christianity in Sub-Saharan Africa* <http://www.pewforum.org/2010/04/15/executive-summary-islam-and-christianity-in-sub-saharan-africa/>, 15 April 2015
- Rottenburg, R. (2009) *Far-Fetched Facts. A Parable of Development Aid*. Cambridge (Mass): MIT Press
- Therkildsen, Ole (1988) *Watering White Elephants? Lessons from Donor Funded Planning and Implementation of Water Supplies in Tanzania*. Uppsala: Scandinavian Institute of African Studies
- UNDP (2015) [Tanzania Human Development Report 2014](#). Economic Transformation for Human Development. Government of the United Republic of Tanzania

## MAPPING AND MONITORING

### Water Point Mapping

---

# Bigger Data : Water For People's Lessons, Doubts and Experience of Mapping Rural Water Supply Systems In Malawi

---

Type: Short Paper

**Authors:** *Muthi Nhlema, Communication and Monitoring Specialist, Water For People Malawi, Malawi, [mnhlema@waterforpeople.org](mailto:mnhlema@waterforpeople.org), +265 (0) 1 830 499*

### Abstract/Summary

In the last 20 years or so, as mobile technology evolved and big data became more accessible than ever, monitoring and evaluation (M&E) has grown in prominence as a distinct discipline (Nhlema,2014). Rather than being an add-on at the end of the traditional project cycle, M&E is now a central tool, not just for assessment of achievement or progress, but also for long-term planning, resource allocation, and improvements and innovation in program design. And M&E isn't just for data crunchers who spend their days hunched over Excel spreadsheets— everyone from graphic designers, communicators, educators, and program officers are using numbers to tell or show a story, teach a concept, or achieve strategic organizational or business goals. This paper will share Water For People's 6 years' worth of experience, successes, lessons and doubts around using the monitoring application, AkvoFLOW, to collect over 40000 lines of WASH data since 2010 in Malawi.

### Introduction

Traditionally, international development organizations and other nonprofits have stuck to a select set of data to report on to their donors, board, and community, based on their mission. They're tracking dollars raised, vaccines purchased, schools built, or lives saved. But as donors have become more critical of the philanthropy sector and demand more data to explain their progress, nonprofits, including Water For People, have realized they need to step up their M&E game.

In the last couple of years as we shaped our mission to provide access to clean water for Everyone Forever, Water For People has made monitoring and evaluation a top priority, in line with our promise to be transparent about our work and our financials. To that end, data and reporting has become integrated into nearly everything we touch—from our Head Quarters and field office operations and program planning, to marketing campaigns and events and fundraisers. We're not just looking at data for data's sake; we're using it to make decisions about whom we support, why, and how we do it. The numbers are our foundation, but the real innovation comes with how we use them to change the game. Our Malawi country office is a great example of how data is being used to inform decision-making around investment allocation at local government level.

Malawi is a Southern African country nestled between Zambia, Tanzania and Mozambique and has a population of close of 16 million people. Even though, government records show a national coverage figure of between 83% - 85%, making it one of the few Sub-Saharan African countries to achieve the MDG target for water supply before the 2015 deadline, such statistics belie a dire non-functionality situation whereby 30% of water supply systems are not functioning at any one time (Ministry of Agriculture, Irrigation and Water Development, 2012). More systematic M&E processes are vital to isolating and addressing such bottlenecks, prioritizing efforts and tracking progress toward better WASH



## MAPPING AND MONITORING

### Water Point Mapping

services for communities. Though there are both institutional frameworks to guide M&E on paper and political acknowledgment of the importance of M&E for informing decision making and investment, this has not translated into increased production and use of development data. This has been mostly due to inadequate financing, bureaucracy, human resource gaps and poor institutional capacity which have hampered the collection, analysis and effective use of WASH data resulting to erratic/protracted data collection, inaccurate/outdated records and waste. In a post-2015 era, where timely and easily accessible data is “*an indispensable element of the development agenda*” (United Nations, 2015), more emphasis, commitment and increased resources will be needed to meet the data demand for the new development agenda: the SDGs; but such an essential endeavor must be a joint responsibility and collaboration between governments, non-governmental organizations, the private sector and civil society, where possible.

It is within this context that Water For People Malawi partnered with the local government in the districts of Chikhwawa, in the south, and Rumphu, in the north, and the public utility company, Blantyre Water Board in the commercial city of Blantyre, to implement the AkvoFLOW monitoring application to help fill the data collection gap to guide problem-solving and development planning.

### Description of the Case Study – Approach or technology

There are currently a number of open source monitoring platforms designed to capture and analyse WASH and health data from the field, these include, to name a few, [www.mwater.co](http://www.mwater.co) and a Malawi-based platform still at beta stage, [madzialipo.org](http://madzialipo.org), which are all free and accessible to sector practitioners.

The AkvoFLOW system has been the primary monitoring platform since Water For People first developed and introduced it in 2010. Initially developed to address errors and problems inherent in paper-based surveys, AkvoFLOW has been proven in use around the world to be easy to use, adaptable and makes it easier to gather, store and share data.

For the past six years Water For People Malawi has been using AkvoFLOW as its primary tool for assessing its impact in reaching Everyone with water and sanitation services Forever in all the target locations we work in. AkvoFLOW is a smartphone app that collects, manages, analyses and displays geographically-referenced data by using:

- Internet-based management tools: design surveys and manage how they are distributed to smartphones
- Akvo FLOW app: field staff can conduct surveys using the app on smartphones and submit the data to online databases;
- Maps and dashboards: make it easy to manage phone users, create surveys and generate online maps to view, explore and share survey data

With an institutional commitment to carry out annual mapping exercises for up to 10 years, Water For People Malawi has worked with local governments in rural districts of Chikhwawa and Rumphu and the public utility in Blantyre City to successfully collect and analyze data.

With AkvoFLOW’s adaptability and flexibility, surveys range from basics on WASH conditions at the household level to customized surveys gauging consumer satisfaction with more desirable sanitation products, e.g. ceramic toilet pans, and pit latrine emptying services. We initially employed a team of expat volunteers from the United States called World Water Corp© to collect the survey data, but this proved an unsustainable model that undermined the capacities of local institutions. So in 2012, the data collection responsibility was shifted to local partners, i.e. local government and NGOs, in the target areas. Since then, Water For People has consistently worked with the same team of enumerators which has helped

## MAPPING AND MONITORING

### Water Point Mapping

strengthen the capacity of local institutions, reduces the need for technical training on the technology which saves valuable time to focus on the survey questions and what they require.

Additionally, rather than offering a remuneration based on number of days in the field i.e. a per-day rate, Water For People Malawi introduced a merit-based payment system based on number of quality surveys collected, as an incentive for enumerators to collect data quickly. To ensure quality control, the data is meticulously reviewed to search for outliers, errors and logical mistakes; any bad dataset found is not paid for which further incentivizes enumerators to collect as much quality data as possible. To inform quality control, a Data Clean-Up Guide is used whereby outliers, errors or logical mistakes are isolated, deleted or re-verified and any major changes to data are recorded for future reference. Depending on the type and quantity of surveys required as per sampling plan, the cost per survey ranges from US\$0.50 to US\$3.00. Comparatively, a mapping assignment in the District of Chikhwawa, covering 2000 waterpoint, 1800 households and 151 schools or clinics, would cost US\$7,140 if a per-day rate was used, while, with the per-survey rate, such an assignment would cost US\$ 7,951, which 11% more expensive than the former payment option. This is the inherent trade-off regarding incentivized data collection: collecting more data in the least amount of time costs more money.

Another plus for the AkvoFLOW system is that by using mobile phones to collect data in the field, the teams save time and reduce errors and bias risk usually associated manual data collation (paper-based). Despite these positive outcomes, there are still challenges with this type of data collection process in Malawi, and we continue to conduct our own surveys and analysis for the most efficient process possible for the districts we work in.

### Main results and lessons learnt

The main result of our mapping model has been the significant increase in the quantity and quality of surveys collected between 2012 to date, standing at 43460 lines of data at the time of abstract submission (see figure 1 below). This volume of data has helped provide a comprehensive picture of the state of WASH in the areas we are working and has helped inform and improve development planning for local governments in Rumphi and Chikhwawa. Annually, Water For People Malawi brings together state and non-state actors in the WASH sector to share the results of the field mapping in an open forum. Besides critiquing the validity of the data, the forum helps stakeholders:

- Gain an understanding of the district-level WASH situation and deliberate on potential causes of problems; ,
- Identify emerging trends in key performance indicators, e.g. level of infrastructure functionality, to inform prioritisation of
- Plan for future interventions to address emerging trends/problems

Rather than showing Water For People's impact, the data illustrates the district-wide progress, thus emphasizing the cumulative impact of incumbent WASH players and approaches.

Another example of how the data has been used to inform planning was in Rumphi district, where the local government previously assumed they had approximately 1000 water supply systems and the district was undersupplied. However, following the mapping, over 3000 water supply systems were discovered and the district was over-supplied, despite a non-functionality rate of 35%. Added to this, it was discovered there were still small pockets of remote communities without any access to an improved water supply system within walkable distance. This data was later shared with local leaders and local government officials as a focus of a productive discussion that brought to question the process of investment planning, data management and infrastructure maintenance. Using a simple GIS maps showing location and functionality of water systems, the district water office re-allocated and altered the number and allocation of 80 new water points scheduled under a an African Development Bank project slated for the district. Additionally, the Rumphi data has been utilised to trigger conversation around enhancing

## MAPPING AND MONITORING

### Water Point Mapping

coordination between the various stakeholder interests around the water resources in the districts; thus the data has provided an objective and apolitical basis for the local government to engage and challenge destructive behaviours around water infrastructure allocation that has proven difficult in the past.

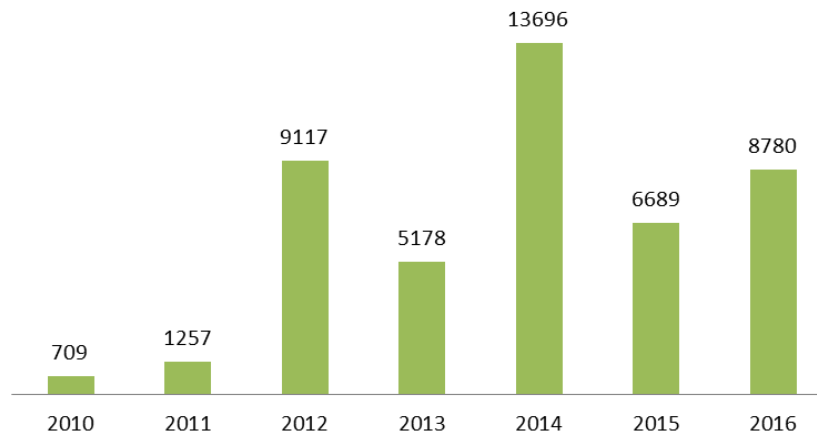

Figure 1: Number of surveys collected by year

Some summarised lessons learnt of our experience include:

- Investing in good enumerators means investing in good data: working with the same team of enumerators has helped instil confidence in use of AkvoFLOW, which was a challenge in the initial stages, and strengthen critical competence for the local institutions we work with to depend on. With each passing year, concerns have shifted from the technology to understanding the questions and what they require. Recently, as part of the mapping methodology, enumerators are brought together to review, critique and revise the questions prior to data collection to alleviate any ambiguity pertaining to what the questions require.
- Good data isn't cheap. As previously highlighted the per-survey rate method costs considerably more money though it generates more quality data more quickly.
- Don't ignore the outliers in your data set. As part of quality control process, all data sets are checked and re-verified for errors, outliers and mistakes before subsequent trend analysis. As part of re-verification, enumerators are re-engaged in open discussion to clarify their data-sets before deletion and subsequent payment adjustments. However, enumerators have, on occasion, challenged the outcome of this verification process, especially when it was not in their favour. One specific case, a field verification team was deployed to validate a data-set that suggested an impossibly low water point yield of 0.003 litres per seconds which was tagged as an outlier. After field verification, it was confirmed that the dataset was accurate and a community, which would have otherwise been disregarded, was included for system rehabilitation the following year.
- Keep it relevant, visual and simple. By using recognisable WASH indicators and simple GIS maps showing water coverage and system functionality, we have seen marked difference in level of engagement with the data from government stakeholders. Particularly, this improved level of engagement has generated meaningful debate around the state of coordination within the WASH sector, as in the Rumphi example, and how best to improve it.
- Don't collect data for data's sake. You have to know, in advance of collecting the data, what you are going to use the data for.
- More thought has to be put into developing a more cost-effective, field-focussed and systematic data validation process.. Ideally, having a secondary source for comparison would be the easiest and fastest method for validating data. However, such a secondary source does not currently exist in the areas we work and those that come close are either inaccurate or outdated. Furthermore, the data-check process in-hand remains desk-based with occasional field

## MAPPING AND MONITORING

### Water Point Mapping

verifications when the data quality justifies field validation. More field verifications are required that are informed by randomised samples of collected data-sets that could be assessed for validation. The trade-off of this approach would be added cost to an already costly mapping process and more time thus defeating the one of the reasons why mobile applications, like AkvoFLOW, were created in the first place: to save time.

- Lastly, but not least, with the increase in the volume and scope of data comes an added layer of complexity in terms of data analysis and interpretation. As such, more skills development is required in the areas of statistical analysis through the use of existing packages, e.g. SPSS and GIS, to enrich the level and quality of analysis beyond the standard water coverage and functionality across a district to understanding the granular water access issues at household level. Such added skills would also help further validate certain aspects of the data, e.g. GPS accuracy, which will help guide improvements to AkvoFLOW.

### Conclusions and Recommendations

There is a growing movement within the WASH sector that is pushing for the integration of mobile technology within government monitoring information systems to help optimise the data collection and analyses portion of development planning. Though the goal of our 6 years’ experience was not primarily to integrate AkvoFLOW within the government, this experience, and the lessons gained thereof, are relevant to providing a wealth of knowledge to this emerging development endeavour.

It is without question, more resources and commitment will be required, if Malawi is to meet the data demands of the Sustainable Development Goals. However, though NGO support is necessary in the medium term, the production and use of WASH data is, and should be, the responsibility of governments. The generation of actionable WASH data in Malawi’s case was a result of external financing and backstopping support to the local government through Water For People. With the low resource environment of local government, this calls to question whether such value-adding applications, like AkvoFLOW, can be sustainably integrated, owned, and paid for by local government themselves; especially when such platforms come at a cost which most local, or even national, governments would not be keen to pay for out of their already stretched budgets and amidst other pressing priorities.

The value-addition furthered by mobile phone innovations such as AkvoFLOW is evident due to the ease of use, efficient analysis and time-saving benefits as proven in use. That said, the cost of installing and implementing such innovations cannot be ignored and, in Malawi’s case, could outweigh the benefits. As such, any attempts aimed at integrating mobile-based monitoring systems/applications within governments must understand what the cost implications will be for governments and further concentrate on addressing the system-finance repercussions. Additionally, institutional inefficiencies, political self-interest and a laissez-faire culture, attributes of most local and national governments, have made existing lower-cost M&E frameworks in Malawi ineffectual, despite some notable attempts to re-invigorate their use. Again, integrating mobile-based monitoring systems/applications within governments must take these into account and, where practicable, address them.

Consequent to this, we would suggest that mobile phone innovations, including AkvoFLOW, must play a more complementary role to the national M&E system of the national government; and not be a stand-alone system operating in isolation. In line with this, the volume of data generated has been shared through AkvoFLOW has been shared with local government to help update existing paper-based monitoring systems which local government are using to inform decision-making and improve service delivery for the rural poor. Until the caveats with AkvoFLOW, abovementioned, are addressed, the use of mobile-based systems/applications to generate big data for development planning will remain limited.

### References

Ministry of Agriculture, Irrigation and Water Development (2012), *Malawi Sector Performance Report 2011*

## MAPPING AND MONITORING

### Water Point Mapping

Nhlema, Muthi (2014), *More is More: Why We Need Monitoring & Evaluation for Long-Term Impact* , Water For People Report

The United Nations, (2015), *Measure what we treasure: sustainable data for sustainable development* , MDG Report

## RAINWATER HARVESTING & SAND DAMS

### Rainwater Harvesting

## 3.6 RAINWATER HARVESTING & SAND DAMS

### 3.6.1 Rainwater Harvesting

---

## Difficulties in replicating success stories: The case of Domestic Rainwater Harvesting

---

Type: Short Paper (up to 2,000 words)

**Authors** *Matthias Saladin (Skat Consulting, Switzerland, [Matthias.saladin@skat.ch](mailto:Matthias.saladin@skat.ch), 0041 71 228 54 54), Ramesh C. Bohara (Swiss Water and Sanitation Consortium, South Asia)*

### Abstract/Summary

A desk study - based on previous field work - was undertaken to compare the experiences and results of promoting the technology of Domestic Rainwater Harvesting (DRWH) in Thailand and Nepal. DRWH comprises a set of technologies and products used to store and use rainwater for domestic purposes, including drinking. Whereas DRWH has been successfully implemented for single households in both countries, only in Thailand this practice reached massive scale and mainstream practice. Using the tool of the Technology Application Framework (TAF) for a rapid assessment of the situation in these two countries, the following key factors were identified to have hindered scaling up in Nepal: user's perceptions and habits, affordability and profitability, and provider capacity. The comparison at hand clearly demonstrates the key importance of contextual factors. Even though similar technologies were used in the two countries, the outcomes were very different. More research on enabling and hindering factors for diffusion of innovations is needed.

### Introduction

Domestic Rainwater Harvesting (DRWH) comprises a set of technologies and products used to store and use rainwater for domestic purposes, including drinking. In rural Thailand, DRWH is extensively used as source of drinking water, and it has been an important factor which allowed the country to reach almost universal coverage - even of the poorest 20% of the population in Thailand, 97% have access to an improved source of drinking water (ESCAP 2009). This success was made possible through massive promotion of this technology in the 1980s under the leadership of Thai government agencies (mainly the Department for Rural Development) followed by a private sector-led phase of diffusion, which allowed for a decentralized mass production of storage vessels and the development of effective supply chains. At the peak use of DRWH around the year 2000, more than 50% of the rural population of Thailand were using rainwater as their main source of drinking water (JMP 2015), which is equivalent to about 21 million people. The widespread use of DRWH in rural Thailand is considered a success story and the historic development of this initiative has been documented elsewhere (EWV 2009, Saladin 2016).

Many people and organizations around the world have tried to replicate this approach in other contexts. One such initiative took place (and continues to evolve) in Nepal. Around 16.4% of the total population lack access to clean and potable water supplies (NMIP, 2014), and rainwater harvesting is considered as an appropriate solution for the households situated on hilltops and along the ridges where gravity flow systems are not feasible and lifting water through pumps is economically not viable. This technology is equally considered feasible in parts of the foot hill zone, commonly known as the bolder belt. In spite of this potential and a seemingly obvious need, DRWH so far only had limited impact: In 2012 there were around 11,000 DRWH systems in use, most of them in the hilly regions of Nepal (NEWAH, 2012).

### Context, aims and activities undertaken

In this article, we summarize the efforts of promoting DRWH in Thailand and in Nepal over the past three decades and reflect on the differences of the two contexts, based on the experience of key stakeholders involved in the process. A retrospective comparison of the two initiatives is carried out, using the tool of the Technology Application Framework (TAF), which has been documented elsewhere (Olschewski and Casey, 2103). We applied the TAF in a theoretical setting, where we used information

## RAINWATER HARVESTING & SAND DAMS

### Rainwater Harvesting

from previous research (Saladin 2016, Bohara 2015) to compile the key information needed for each key stakeholder (interviews with several individuals were summarized in a generic profil for each stakeholder). In this article, we are pointing out the main factors which made the promotion of DRWH in Thailand successful and only partially successful in Nepal and make some general recommendations for promoting DRWH in different contexts.

#### Main results and lessons learnt

The experience of Thailand in getting the collection and use of rainwater for domestic purposes (including drinking) into mainstream provided an example of how DRWH can contribute to increased access to improved water sources, also for the rural sector and also for low-income households. This process evolved over a period of more than 30 years and can be summarized as follows (the following is a simplification of the process which involved dozens of key players in a complex and dynamic process – more comprehensive descriptions of this process have been provided by EWV 2009 and Saladin 2016):

1. 1980s: National government agencies take the lead: setting policies, defining goals, making plans.
2. Developing the design of adequate products (jars, gutters, plumbing, roofing) and training of thousands of artisans to fabricate the products and deliver services (maintenance and repairation of jars).
3. Stimulate demand and support mechanisms for demand satisfaction (including group credit schemes). During this first phase, materials were subsidized by government agencies.
4. In a second phase (1990s), subsidies stopped and the private sector took over the lead from government agencies. Fierce competition set in and brought the prices further down. Mass production capacities in several locations (clusters of producers), combined with a functioning transport sector, allowed for mainstreaming of DRWH.
5. In a next phase, DRWH reached its maximum outreach (around 50% of rural population around the year 2000) and now is slowly being pushed out by solutions which allow for an even higher service level (piped networks, bottled water, etc.). However, people continue to collect and use drinking water for domestic purposes. Government, through the Ministry of Health, focuses its role on water quality surveillance of the different DRWH systems (as well as other water sources).

This is a very rough description of the experience of DRWH promotion in Thailand, also referred to as the “Thai Experience”, which was a strong inspiration for many people and organizations around the world. Here, we describe the example of Nepal, where efforts were undertaken to replicate or simulate the Thai Experience. The experience can be summarized as follows:

1. Pilot demonstration projects (to harvest rainwater systematically at household level) by pioneer organizations (namely the Rural Water –Supply and Sanitation Programme financed by FINNIDA) started in 1996
2. Acceptance by local authorities, inclusion of DRWH into national policies in 2009
3. Promotion by government agencies, supporting the installation of more demonstration units
4. Replication by other donors on a small scale

In 2009, to ensure proper utilization and conservation of water resources, the Government of Nepal, Ministry of Physical Planning and Works (MoPPW) prepared a working policy on rainwater harvesting to promote suitable developments in rainwater harvesting for human consumption and domestic use, and facilitate guidance and capacity building (MoPPW, 2009). Nevertheless, DRWH is considered a low-priority intervention by government agencies at most levels, which clearly contrasts with the strong backing up of DRWH promotion observed in Thailand.

Overall, it can be stated that there is sustained use of DRWH in some pockets of the rural population of Nepal (typically houses on hilltops where the gravity driven supply systems can not reach), but no “ripple effect” and no scaling up was observed until now. This is likely due to a series of factors which are related to the local context. In order to analyse and illustrate these factors, we used the tool of the Technology

## RAINWATER HARVESTING & SAND DAMS

### Rainwater Harvesting

Applicability Framework (TAF), which is described in more detail elsewhere (Olschewski and Casey, 2103).

The following illustration summarizes the situation in the two countries, looking back at the situation over the past 20-30 years.

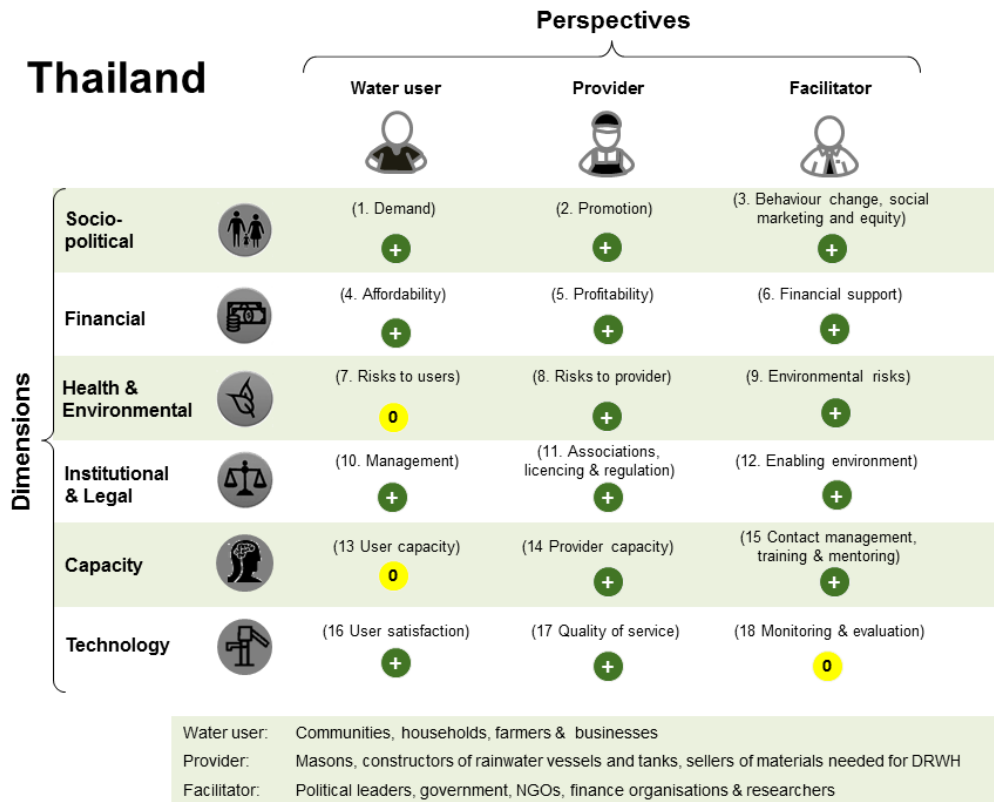

Fig 1: TAF Scorecard of DRWH in Thailand



RAINWATER HARVESTING & SAND DAMS

Rainwater Harvesting

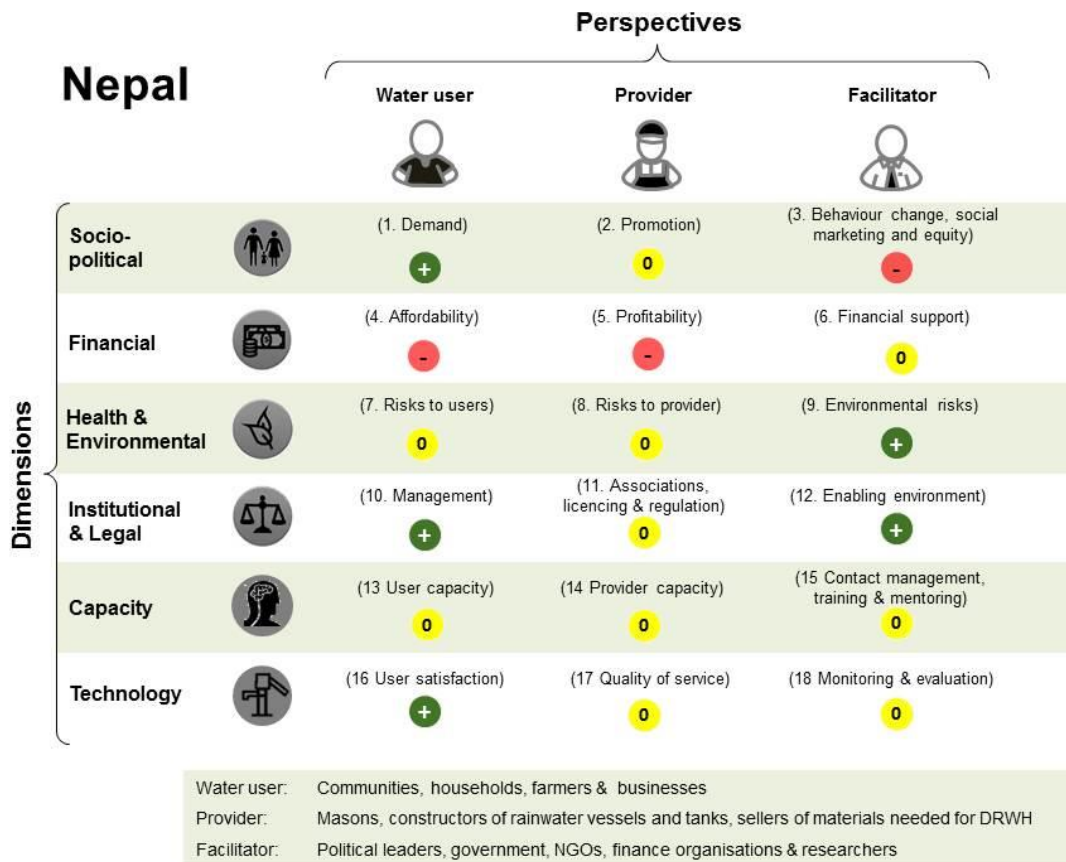

Fig. 2: TAF Scorecard of DRWH in Nepal

As can be seen from the figures, the overall picture for Thailand looks much more positive (more positive and neutral factors, no negative factors) than for Nepal. The overview allows to quickly identify the main factors which hindered a widespread use of DRWH in Nepal, which will be further described here:

*a. Behaviour change*

Rainwater harvesting and its consumption is a tradition which goes back centuries and even millennia in Thailand – for people living in rural Thailand in the 1980s, it was very common – and indeed desirable – to drink rainwater. Due to cultural factors (including religion), rainwater was considered the purest form of drinking water. Even before the consumption of rainwater was promoted by state agencies and NGOs in the 1980, the habit already existed.

This is quite different in rural Nepal: many people - especially the ones in the hills who are used to drink spring water – have doubts about the quality of rainwater. Several Government agencies actually support and promote DRWH, but culturally, there is a popular myth in Nepal that "flowing water is the purest water and stored water becomes impure (baasi paani)" (Bohara 2015). They have to be convinced that drinking rainwater is acceptable and not harmful. This different perception and habit makes the promotion of DRWH in Nepal much more difficult and resource consuming in comparison to Thailand. People generally accept to use rainwater for domestic purposes but when it comes to drinking they prefer walking a long distance to fetch spring water for drinking. Nevertheless, some hardship areas that are devoid of springs in a reasonable vicinity do use rainwater for drinking. Thus, convincing people to accept it as the prime source for drinking water is an uphill battle – it is possible, but it takes more time and resources than in other contexts.

*b. Affordability*

While the 1,500-2,000 litre cement mortar jars in Thailand were sold in the 1990s at 20 USD per unit, the price of ferro-cement tanks in Nepal in the last 15 years was much higher. Costs of a typical 6,500 litre jar

## RAINWATER HARVESTING & SAND DAMS

### Rainwater Harvesting

are around 375 USD per unit. This has to do with the fact that materials (cement, sand, etc.) are more expensive in Nepal and transportation of these construction materials in the remote hills, often by headload, makes it even more expensive, but also with the fact that in Thailand mass production was established, which was not possible in Nepal because of a different market structure (a few customers living scattered in hard-to-reach areas) and because less space is available around most houses in hilly parts of Nepal, thus allowing for only one jar (whereas multiple jars per household are very common in Thailand). High material costs and high transportation costs, combined with artisanal production (compared to mass production) make DRWH systems very costly to build in Nepal – and there are other competing technologies which are more affordable or more attractive from a user's perspective.

Another factor related to affordability is the fact that in Thailand in 1980, more than 80% of women were participating in the labour economy (Bauer 2001). This meant that every hour not spent on fetching drinking water could be invested into financially productive work, thus creating a strong incentive for investing in DRWH systems and for continuously increasing the storage volume. In short – DRWH paid off for the family financially in Thailand whereas the time savings gained by Nepalese women could not be directly converted into financial gains. Nevertheless, the time savings in the Nepal study were estimated at 6.35 hours per family per day, which are very important and allowed the women and girls who usually are in charge of fetching water to dedicate more time to other activities, which they perceived as a great relief.

#### *c. Profitability*

Profitability is closely related to affordability, but it focuses more on the producer/provider: where there only is a small market to be served, with only the poorest as potential customers, the producers and providers will always rely on external funding to be able to sell their product. This reduces profitability and does not foster competition, which in turn would allow for prices to come down over time.

Because of the high costs of DRWH systems in Nepal, most of these have been constructed by NGOs with substantial subsidies (either direct or indirect subsidies). Private sector has played a relatively minor role, partly because the profitability of the technology is limited but also because the strong position of the NGOs and the policies implemented by them, often bypassing local delivery channels and thus hindering an adequate development of local entrepreneurs and supply chains.

The low profitability of DRWH also is a factor which limits the capacity of the providers: Even if many people would have been trained in providing professional services related to DRWH, the chances are high that they would end up in doing something else because in the Nepali context, other professions and activities offer better earning opportunities. Therefore, in the scorecard, “Profitability” was marked negative for being a bottleneck, whereas “Provider Capacity” was marked neutral, indicating a potential hindering factor but in the current setting not being a bottleneck.

### Conclusions and Recommendations

Various studies regarding RWH in Nepal revealed that the technology has a potential and can be implemented adequately in various settings. However, when it comes to bringing the technology and the implementing mechanisms to scale, there are a number of hindering factors which need to be addressed. In particular, more attention needs to be paid to cultural aspects (e.g. the perception of current water quality from springs and the perception of quality of rainwater), and a more thorough analysis of the potential market needs to be carried out prior to setting up demonstrations modules or pilot projects. The point of view of the final users as well as of the producers/providers are crucial factors to take into account by government entities, NGOs and funding agencies when planning projects and initiatives.

The success story of DRWH promotion and use in Thailand proved difficult to replicate in other contexts – here we highlight the case of Nepal. The main hindering factors were not of technological nature but related to context – most importantly cultural aspects (acceptability of drinking rainwater and its perceived quality) and market factors (price and availability of the materials, competition, and labour force participation of women). When promoting novel technologies in a given settings, such factors need to be taken into account from the onset of an initiative, and more effort needs to be undertaken to link live-saving technologies with productivity (which, like the case of Thailand showed, can happen through time savings for not having to fetch water).

## RAINWATER HARVESTING & SAND DAMS

### Rainwater Harvesting

Our study is not a general evaluation of the success or failure of DRWH, but rather a comparative study on two different settings and their impact on the proliferation of a specific technology (DRWH) therein. Using a relatively simple tool for analysis and illustration, we were able to identify key factors which hindered DRWH to become a mainstream technology in Nepal up to date. With the same tools, other technologies and other context can be analysed in a fast and cost-effective way in order to optimize diffusion strategies and make best use of the resources available. The tool also makes sure that due importance is given to different points of view. We recommend its further use, both at the planning stage of a project/initiative but also during its implementation, given that its holistic focus allows to quickly focus on bottlenecks, which then can be addressed properly.

For the specific case of DRWH promotion in Nepal, we propose to pay more attention to the three factors which most hinder its proliferation: common perceptions of the quality and adequacy of rainwater as a source of drinking water, the affordability and profitability of the technology, and the capacity of the providers.

We invite researchers, implementers and promoters of DRWH and other technologies to further investigate cases like the ones presented here – both successful and not - to shed more light on the importance of different contextual factors.

### Acknowledgements

We herewith thank RAIN Foundation, SDC and Skat Foundation for supporting the work which lead to this article.

### References

- Bauer, J 2001, 'Demographic Change, Development and the Economic Status of Women in East Asia', in Population Change and Economic Development in Asia, Andrew Mason (Ed.), Stanford University Press, Stanford, USA p.361
- Economic and Social Commission of Asia and the Pacific 2009, *Statistic Yearbook for Asia and the Pacific*, United Nations Publication, ISBN: 978-92-1-120606-7, Bangkok, Thailand, pp.75-77, viewed on 20.04.2016 <http://www.unescap.org/stat/data/syb2009>
- Bohara RC (2015), 'Sustainability of Rainwater Harvesting for the Domestic Needs - A Case Study of Daugha VDC, Gulmi, Nepal', MSc Thesis, Pokhara University, Pokhara, Nepal.
- EnterpriseWorks/Vita 2008, *Domestic Rainwater Harvesting, Field Study Report*, 2008, viewed on 22.08.2015, <http://www.rural-water-supply.net/en/resources/details/716>
- MoPPW, 2009, *Working Policy on Rainwater Harvesting*. Kathmandu: Ministry of Physical Planning and Works Government of Nepal.
- [Joint Monitoring Programme 2015, Data sheet Thailand, viewed on 30.04.2016, http://www.wssinfo.org/documents/?tx\\_displaycontroller\[type\]=country\\_files](http://www.wssinfo.org/documents/?tx_displaycontroller[type]=country_files)
- Olschewski, A. and Casey, V. [TAF: Processes for strengthening the sustainability and scalability of WASH services. Development of the Technology Applicability Framework and Guidance for Technology Introduction - Research Report](#). WASHTech Project, 2013.
- Saladin, M 2016: Rainwater Harvesting in Thailand: Learning from the World Champions. RWSN Field Note, RAIN/RWSN, St. Gallen, Switzerland.

## RAINWATER HARVESTING & SAND DAMS

### Rainwater Harvesting

---

# Using the Revolving Fund Approach to Scale-Up Rainwater Harvesting in Uganda

---

Type: Short Paper

**Authors Names:** Walugendo Kyesa Sulaiman

*Position:* National Coordinator

*Institution:* Uganda Muslim Rural Development Association (UMURDA)

*Country:* Uganda

*email address:* [walugendos@gmail.com](mailto:walugendos@gmail.com)

*Telephone number:* +256 772 604 449

### Abstract/Summary

Rainwater harvesting is a component of Self-Supply and its financing has been the wide spread desire for people. With challenges associated with Conventional approaches and the sense of ownership and control bestowed to rainwater harvesting many individuals, private companies and Institutions value the technology for its convenience. In order to promote Rainwater Harvesting in water stressed areas in the country, the Government of Uganda through NGOs nationwide using subsidies of 60%. Lessons from this type of financing have been that: the biggest percentage of funding is external and demand is externally driven; high subsidies make it difficult for the beneficiaries to judge which tank size they can afford. The project failed to scale up beyond the pilot areas due to: Poor advocacy and marketing; Limited public funding of 60% subsidy; inability of rural beneficiaries to raise the huge cost of the tank at once and the high cost of credit financing from Financial Institutions. Rainwater Harvesting using a Revolving Fund Approach is a proposed solution to contribute to SDG 6 where beneficiaries in rural areas are empowered to choose technology type they can afford to finance at affordable terms.

### Introduction

This paper is intended to focus on challenges faced by donors and Governments as far as Rural Water Supply is concerned. The lessons derived from the challenges and the step of using a Revolving Fund Approach as a possible solution to rural water financing, which Uganda Muslim Rural Development Association (UMURDA) is implementing at the moment lessons learnt, the challenges faced, recommendations and conclusion.

In Uganda Rural Water Coverage had stagnated at 64%<sup>133</sup> over the last three years. This calls for innovative initiatives to close the gap.

A Self-Supply Study conducted in 2005 in 9 districts in Uganda found that the conventional protected supplies were not sustainable in all situations and the apparent continued popularity of the traditional sources they were designed to replace continued to flourish. The study found plenty of evidence that 75%<sup>134</sup> of water sources were of Private and Community initiatives shared with not charge. There was also barriers to encouraging self-supply source improvement such as official discouragement off what are regarded as poor quality supplies; lack of mechanisms to support individual ventures and generally lack of awareness by Professionals in what people already do for themselves

The study proposed support to: low cost incremental source improvement technologies ; private sector supply owners to develop water sources for the common good; Private Sector Operators for management and maintenance dealing with households directly not through committees ; Artisans be given training, equipment and access to credit.

---

<sup>133</sup> Sector Performance Report 2014

<sup>134</sup> Carter et al 2005

## RAINWATER HARVESTING & SAND DAMS

### Rainwater Harvesting

The findings stimulated debate amongst stakeholders at National Workshop organised by UWASNET in November 2005. This increased awareness that both ground water and rainwater harvesting could offer household level solutions.

After the Study, the Ministry of Water and Environment and African Development Bank (ADB) Piloted Self-Supply in (2006-2008) Nationwide using NGOs (NETWAS, UMURDA, Busoga Trust, ACORD, COWESER and WEDA)<sup>135</sup>

This was a demonstration of what can be done. The NGOs encouraged households to improve their own water supplies, with no, or very low subsidies. UMURDA worked mainly on communal sources, with a particular emphasis on springs, whilst WEDA worked more with privately owned supplies, especially shallow wells<sup>136</sup>.

A study for Enterprise Works<sup>137</sup> in 2009 identified about 30 distinct rainwater harvesting products<sup>138</sup> ranging from 20 litres to 10,000 litres.

Government supported this technology and in 2006, District Local Governments were allowed to construct demonstration RWH facilities and train masons from their Water and Sanitation Conditional Grant. RWH was first included in national safe water coverage estimates in 2006. In 2008, a rainwater harvesting training centre was opened in Kabaale. This centre trained 8 UMURDA masons in Tank construction in 2008 and UMURDA has since trained 28 local masons in the districts of Kamuli, Iganga, Bududa, Manafwa and Namayingo.

The pilot was successful and the Ministry of Water and Environment established an *Appropriate Technology Reference and Development Centre* in Mukono district to promote rainwater harvesting alongside other technologies. Indeed, the popularity of DWH as a viable technology option for rural water supplies continued to grow within institutions and among individuals.

However, the Pilot failed to be scaled up because of a number of reasons: There was limited public funding of 60% subsidy to trigger its up-scaling; inability of beneficiaries to raise 100% cost of the facility at once; high cost of credit financing from Financial Institutions; poor advocacy and marketing for RWHs; limited capacity at Local Governments and community levels to embrace the technology.

After preparing for implementation of 60:40 ratio, the President of the Republic of Uganda directed the review of the strategy of subsidy and donations of RWH because it was not sustainable. The conditional grant that was being used on RWH was stopped forthwith.

The Rain Water Harvesting financing was reviewed in order to address the gaps in the strategy. The positives of the review were that RWH has been on practice for quite long, a wide choice and types of tanks is available, yet Operation and Maintenance of tanks is perfect; there was a number of NGOs that were capacity built in the technology also SACCOs<sup>139</sup> were becoming popular and could manage the Revolving Fund. The challenges of the technology that it required a huge initial pre-finance that the rural people could not afford; the Government and Development Partners do not have enough resources to finance 60% subsidy for each deserving household across the country.

The proposed solution was to use NGOs to promote Rainwater Harvesting using a “**REVOLVING FUND APPROACH**” The tank beneficiaries are empowered to choose a technology type they can afford to finance at affordable terms. The re-payment period is spread out for a minimum period of one year.

### Context, aims and activities undertaken.

<sup>135</sup> Network for Water and Sanitation, Uganda Muslim Rural Development Association; Agency for Cooperation and Research in Development; Wera Development Association

<sup>136</sup> Accelerating Self Supply (A Case Study from Uganda 2010) Kerstin Danert and Sall Sutton

<sup>137</sup> Danert and Motts 2009

<sup>138</sup> Jerricans (20), moulded plastic drums, steel drums; cement jars; plastic tanks; above and ground lined tanks; above and ground ferro-cement tanks and flexible membranes.

<sup>139</sup> Savings, Credit and Cooperative Organisations

## RAINWATER HARVESTING & SAND DAMS

### Rainwater Harvesting

UMURDA is one of the 4 NGOs<sup>140</sup> that entered into partnership with the Ministry of Water and Environment (MWE) to promote the RWH project using a Revolving Fund Approach in 4 districts<sup>141</sup> respectively.

The MOUs were signed spelling out the roles and responsibilities of each party in the implementation of the project and to introduce the concept of how the project will be planned, implemented, managed and operated.

#### 2 Project Financing

The project started in 2015 when the Ministry of Water and Environment (MWE) contributed UGX<sup>142</sup> 77,000,000 (USD<sup>143</sup> 22,000) and UMURDA contributed UGX 25, 000,000 ( USD 7,140)<sup>144</sup> . 85% of the funds is for Tank Construction, 10 % for operational cost and 5% to construct tanks for the vulnerable ones. UMURDA is providing tanks of capacity 6,000- 20,000L to beneficiaries on “credit” and the credit repayments are to be returned and given to other community beneficiaries.

UMURDA developed a Rainwater Harvesting Credit Policy to guide in Provision and management of the Revolving Fund effectively without **Riba**<sup>145</sup>

Application Forms and Loan Agreement for both households and Institutions to acquire the credit were designed.

#### ACHIEVEMENTS

After the National project Launch in Mukono in April, 2015, UMURDA has carried out a number of activities including Stakeholders Planning meeting in Namayingo district which resolved the project be implemented on the mainland and Sigulu Islands was to be considered later because of the high costs of local material and transportation. The project was launched in the district with the main objective of carrying out advocacy for the Revolving Fund Approach.

Six local Masons were selected and trained in Ferro-cement tank construction to capacity build the community in practical skills of construction, Maintenance and marketing of the tanks. There is a continuous sensitisation of communities using the Mass media and Local Leadership about the approach and to show to them that it is intended to promote access of WASH for all including those in water stressed areas.

**Tank Construction:** The exercise of Tank construction started with the issuance of Application Forms to the would be beneficiaries to understand the terms, fill them in and return them for verification. The assessment include:

- i) Whether the Applicant is recommended by Local Council one and is a bonafide resident of the area.
- ii) Next of keen in the family has witnessed the signing of the Applicant.
- iii) Has Iron roofed house that can attract a tank of 6,000L and above depending on the number of family members.
- iv) Whether the house has a Facier Board.

After verification the Application Form is forwarded to UMURDA Management for Approval /Disapproval. When approved the Applicant is invited to discuss the Terms of the Agreement and then sign.

#### Revolving Fund Management.

<sup>140</sup> 1. Busoga Trust,2, Katosi Women Development Trust 3. Sheema Development Agency and 4.Uganda Muslim Rural Development Association

<sup>141</sup> 1.Luuka 2. Mukono 3. Sheema and 4. Namayingo

<sup>142</sup> Uganda Shillings

<sup>143</sup> 1USD= 3,500 UGX

<sup>144</sup> UMURDA contribution (a Motorcycle, labour and training of Masons).

<sup>145</sup> Free money received without working for it in Islam.

## RAINWATER HARVESTING & SAND DAMS

### Rainwater Harvesting

After signing the Loan Agreement a File is opened up and a Client is issued with an invoice showing the total loan and a Ledger Account is opened to track repayments. Acknowledgement receipts are issued from the Office on every repayment made. The Agreement outlines the Loan amount (Cost of the tank including 5% operational cost), duration of the Loan and repayment schedule. Periodically funds collected is banked by the Administrative Assistant and banking Slips submitted to the Finance Office.

The funds collected from clients is for re-cycling to operationalise the Revolving Fund strategy.

#### **Tank Construction.**

When Applicant avails local material and confirmed by the Field Officer the external material are delivered to the site and arrangement is made to start work.

The technology being promoted by UMURDA is Ferro cement tanks and the external material a part from cement no single hardware stockist can have all the assorted items and they are not common in the district and other material need fabrication. So procurement is done by UMURDA’s experienced Project Officer who is conversant with specifications with support from the Coordinator.

### **MAIN RESULTS.**

- 1) The district stakeholders have contributed to the dissemination of information about RFA differentiating it from the conventional and subsidy methods.
- 2) There is increased awareness about the RFA as a result of using Radio Talk Shows reflected from calls requesting for Application Forms and more information.
- 3) Six Local Artisans were selected from within the district and trained in skills of Ferro cement construction.
- 4) There is demand for RWH tanks in the district resulting from advocacy and marketing of Ferro cement tanks.
- 5) Over 100 people picked Forms and 70 Applicants returned the forms, 26 Applicants fulfilled the minimum requirements and 22 have received tanks on credit payable in periods of 12 months.
- 6) More applicants are in the process of fulfilling the minimum requirements tank construction.
- 7) 22 Tank beneficiaries have been trained in O&M of the tanks, hygiene and sanitation at household levels.
- 8) Clients are re-paying the credit to UMURDA according to the schedule agreed up on in the Loan Agreement and so far UGX 7,136,200 has been paid and it is being recycled.
- 9) 5 Tanks for the vulnerable ones have been constructed
- 10) More Application forms are being picked and others brought back requesting for Loan Agreements for Revolving fund

The **external** or **internal** factors that have significantly influenced the achievements include:

- i) Willingness by beneficiaries to purchase tanks on credit because of the challenges they have in accessing water in the district.
- ii) Commitment and experience of UMURDA in constructing quality tanks.
- iii) Support from district Local Leadership to participate in promotional activities such as Radio Talk Show and launch.
- iv) MWE released funds to UMURDA to start giving Tanks on credit to clients.

#### **Main results and lessons learnt.**

The external or internal factors that have significantly influenced the achievements of these outputs positively include:

- i) Willingness by beneficiaries to purchase tanks on credit because of the challenges they have in accessing water in the district.
- ii) Commitment by UMURDA
- iii) Experience in Rainwater tank construction by UMURDA

## **RAINWATER HARVESTING & SAND DAMS**

### **Rainwater Harvesting**

Support from ATC, TSU4 and district Local Leadership.

#### **Lessons Learnt**

##### **a) Grass thatched houses and Rural Growth Centres**

The Revolving Fund Approach only targets individual households that have iron roofed houses and have the capacity to pay; it ignores communities’ capacity to pay for a larger capacity tank of 250,000 Litres or more.

##### **b) Training of Masons in Kenya:**

UMURDA and Busoga Trust sponsored their masons to go and train in Kenya so that they can be able to construct tanks of 250,000 and 500,000 L. This would enable Institutions, households in rural growth Centres and those with grass thatched houses to get tanks that can supply them with water and they pay as they use the water.

##### **c) Demand for RWH Tanks.**

Many house-holds are now aware of the advantages of RWH tanks and are able and willing to invest in them to make improvements to their own water supplies as reflected from the number of Application forms picked and the requests from other districts where UMURDA is operating with different programmes.

##### **d) Income Generating Activity**

Those who got tanks use them as an income generating activity by selling water to get money to pay the credit and for attaining food security thereby improving their lives.

##### **e) Lake Victoria Shores**

People near Lake Victoria are the ones demanding highly for the tanks because are some of the pockets of the district which are particularly difficult to serve with the main conventional technologies. Many boreholes which UMURDA constructed with support from GOAL have been submerged and abandoned. Water is salty and hitting dry wells is very common.

##### **f) Donations Culture**

Water users are used to conventional water facilities which in most cases are put in place with high subsidies or as a donation and they think the tanks are also for free.

##### **g) Economic Activities.**

Many of the clients of RWH tanks are those that have economic activities that need water such as Brewers of alcohol, bars and hotel owners, poultry and animal rearing.

##### **h) Happy Clients**

Those who got the tanks are happy because they have access to safe and clean water and they seriously guard it under key and lock.

##### **i) UMURDA Accessibility**

It is easy for people who need tanks to approach UMURDA for a credit for the tanks than going to the Financial Institutions to get cash loans to finance the construction of tanks.

#### **CHALLENGES**

1. Rain Water Harvesting tanks using a Revolving Fund Approach is considered that it is for those who are well off because 80% of those who have got the tanks have solar in their homes.
2. Many of the tank clients claimed the money is got from farming and were requesting the re-payment period of 12 months to be increased to 24 months to include the farming seasons.
3. The project is not focusing on RWH tanks of bigger capacities that can cater for people in Rural Growth Centers and schools of more than 400 persons.
4. There is lack of a GPS to capture the tank codes.
5. The Work plan is not followed as funds are not released timely and as requested.



## **RAINWATER HARVESTING & SAND DAMS**

### **Rainwater Harvesting**

6. The project has no funds to construct a 250,000 and 500,000 L tanks for the Communities and Institutions even for piloting them in Uganda.

### **Recommendations**

1. There is need of investing more in marketing of tanks through Massa media and advocacy.
2. There is need providing of large scale tanks of 250,000 – 500,000 Litres at Institutional and community levels in the district and they pay as they use.
3. The Government should support UPE schools to get rainwater harvesting tanks or come up with guidelines for UPE schools to contribute to the construction.

### **Conclusion**

Given the poverty levels in Uganda Revolving Fund Approach is one of the strategies to be used to promote RWH which is the future solution to tackling water crisis in rural areas especially in water stressed areas

### **Acknowledgements**

I extend my sincere appreciation to Engineer **Ian Arebahona** who without any reservation provided me with a wealth of knowledge regarding a Revolving Fund Approach in relation to Rural Water Supply and also for reading the draft of the Short Paper for presentation.

I would like to especially mention **Professor Richard Carter of Cranfield University** for the guidance he gave us to understand deeply the concept of self-supply during the study of Self-supply in Uganda and the piloting of the first project of self-supply.

**Dr. Moses Musitwa** Rotary Club of Ntinda is appreciated for giving me the opportunity to participate in Rotary WASH Rag International Summit 2016 that was held in Uganda where I presented a paper on Rainwater Harvesting Technologies and it has inspired me to write this Short Paper for presentation in RWSN Forum

The Technical Support Unit 4 Team Leader **M/S Opira Rita** is acknowledged for providing information regarding documentation regarding the Management of the Revolving Fund by involving

The opinions expressed herein are mine and do not necessarily reflect the views of UMURDA or the Ministry of Water and Environment.

Finally, I wish to acknowledge **Engineer Mwandha Christopher** the District Water Officer for his participation in the project right from the beginning of the project up to date the continued guidance to the project in his areas of expertise.

### **References**

1. Accelerating Self Supply (A Case Study from Uganda 2010) Kerstin Danert and Sally Sutton.
2. Self-Supply: A Fresh Approach to Water for Rural Populations (Water and Sanitation Programme (WSP) and Department for International Development (DFID)).
3. Strategy for Up-Scaling Domestic and Institutional Rainwater Harvesting Using A Revolving Fund Approach In Uganda ( A paper presented by UMURDA in ROTARY WASH INTERNATIONAL SUMMIT 2016 District 9211) in Uganda

## RAINWATER HARVESTING & SAND DAMS

### Rainwater Harvesting

---

# Transformation with technology- The story of a pilot rainwater-harvesting and Community-Based Climate Change Adaptation project in Rwanda.

---

Type: Long Paper (up to 6,000 words)

#### Authors

**Lead Author:** *Karulinda, Emmanuel, Programme Officer, Sustainable Livelihoods and Environmental Justice, Trocaire Rwanda.*

#### Other Authors

*Hogan, Rose, Bizimana, Xavier ; Gasasira, Claudien ; Ngabo, Janvier and Safari, Jean Baptist*

#### Abstract/Summary

This short paper describes an 18-month pilot project in 9 villages in upland Rwanda in which provision of technologies for rainwater harvesting from rooves and ground catchments was combined with whole-community engagement in Water Resources Management. The purpose was to increase smallscale farmers' resilience to climate change with a particular focus on homestead vegetable gardening using harvested water. The physical aspects of the location are briefly described with information compiled from hydrological studies to ascertain best technologies to fit the circumstances. The technologies and their installation are described. The processes and resulting water resources management plans made by village communities are also described. The development of human capital – training for maintenance and management and organisational capacity is also described. Reflections are made on the householder and community reactions and achievements. Lessons learnt are listed and recommendations are made for follow-on support and for start-ups elsewhere throughout Rwanda or further afield

#### Introduction

Rwanda faces food insecurity and high population pressure on resources, increasing its vulnerability to the impact of climate change. Currently, the average family landholding is 0.5 ha and the population growth rate is 2.76%. The situation is compounded by over 87% of the population being dependent on agriculture, with limited capacity to manage the impact of seasonal droughts and floods.

Although Rwanda has two rainfall seasons, which produce sufficient rainfall in all regions, seasonally and due to more erratic seasonal distribution, there is insufficient water to support agricultural production. Precipitation is the main source of water for agricultural production in Rwanda but its distribution in time and space with about half of the precipitation occurring in one quarter of the year is critical. Less than 2% of its available water resource is used for agricultural purposes, whilst the rest is lost due to poor management. The drought of 2013 greatly reduced yields and affected the poorest households most seriously.

From World Bank Agricultural progress report 2014, **Hillside irrigation** was developed during PSTA 2 on 2,490 ha compared with the target of 13,000 ha. A major reason for this gap was its high cost of up to US\$23,000 per ha. This compares with the cost of small-scale irrigation schemes of about US\$1,500. Cost recovery requires high-value horticultural or other high income crops. Additional **Land area under consolidated use** was established for increased land area for cultivation. It was an important focus of the government crop intensification program by improving the efficiency of land use and facilitating extension. Actual results were significant. From 28,788 ha of total area under consolidated use in 2007, it rose to 502,916 ha in 2012. Although farmers had some reservations in the beginning, most became willing converts once the benefits were established of achieving economies of scale in securing inputs and marketing production.

## RAINWATER HARVESTING & SAND DAMS

### Rainwater Harvesting

Given this challenging context, the Integrated Water Resources Management (IWRM) approach is promoted as a potential solution to some of Rwanda’s development challenges (REMA, 2014). Indeed the IWRM approach was identified by the Water Resources Management Sub-sector Strategic Plan (2011-2015) (Republic of Rwanda, 2011) with three objectives:

- Protect, conserve, sustainably manage and develop Rwanda’s water resources in an integrated and sustainable manner;
- Ensure adequate quality and quantity of water resources are available to facilitate socio-economic development; and
- Ensure that decisions affecting water resources’ management are made in a coordinated manner and with the participation of all stakeholders, at national and trans-boundary levels.

The Water Resources Management Sub-sector Strategic Plan (2011 – 2015) has supported the rehabilitation of water catchments, the development of rainwater harvesting initiatives and improved storm water management, climate change mitigation and improved energy efficiency. These innovations, however, must be scaled up, consolidated and shared as lessons learned across the country. The main challenge is to protect catchments and utilise water much more efficiently, in the context of declining water resources due to environmental degradation, climate change and an increasing population. Community-led catchment management has not previously been applied in Rwanda where whole-community participatory processes are uncommon and skills in Participatory Rural Appraisal and planning are not well developed. Demonstration rainwater harvesting (RWH) technologies have been installed in schools and on roadsides but are not widespread throughout the country. Skills in installation of plastic, ferrocement, bamboo and poly-lined ponds and semi-underground tanks are available in a few locations. A national Rainwater Harvesting Network had previously been established but was found to be inactive.

### Project Area Profile

The Project geographical focus is nine villages from three Districts of the Southern Province of Rwanda namely **Nyanza, Nyamagabe and Kamonyi** as follows: Rubanga and Nyarusange villages in Kamonyi District, Gikomero, Gatara, Nyarugeti, Ngororero and Uwinyana in Nyamagabe District and Bweru and Mpaza villages in Nyanza District. The altitude ranges between 1300 meters and 2700 meters, Nyamagabe being the highest. All villages have steeply sloping topography, although there are differences between the four areas (*See topographical maps 1,2 & 3 showing hydrological features*). All areas experience a short rainy season from September to November and a long rainy season from February to May. The short dry season runs from December to January and the long dry season from June to mid-September. The annual rainfall varies from 1200 to 1450 mm and average temperature ranges between 17 and 20 °C, Nyamagabe being the coolest and Kamonyi the hottest. Vegetable farming and animal husbandry are the main economic activities. Other activities such as commercial activities and construction manpower are done by a small number of households. During the baseline study of 122 households (HH) using the Ministry of finance’s *ubudehe* system of six poverty classifications, no household was classified as ‘resourceful poor’, ‘food rich’ or ‘money rich’ which are the three richest categories. Approximately half of the sampled households are classified as ‘poor’ and are in category 1 of national *ubudehe* classification, while 38% are ‘very poor’ and 10% are in ‘abject poverty’ and are in category 2 of national *ubudehe* categorization done by the community members in a participatory manner. The majority of plot sizes per household are in the range of 0.61-0.85 hectares. Approximately 75% of households possess either poultry or other livestock. The most common source of energy for cooking is wood. Although government statistics show that Rwanda has turned around the trends in deforestation (REMA 2015), there is evidence of water resources degradation due to the removal of woody species. Trees and shrubs are cut and crop residues are used for fuel such that soil is exposed to erosion due to extreme shortage of fuelwood especially in Kamonyi. Changes to cropping such as the substitution of bananas by root crops such as Irish potatoes and cassava/manioc have led to a comparatively higher level of soil disturbance at harvest of the root crops which has increased erosion in agricultural lands. Pressure to produce adequate food and cash crops means that three cultivations of the land take place each year thus loosening soil structure, increasing evaporation and increasing vulnerability to erosion.

## RAINWATER HARVESTING & SAND DAMS

### Rainwater Harvesting

During a baseline survey done by Trocaire in January 2015 across 8 villages among 9 targeted by the project most (85.%) of the 122 respondent households (60% Female Headed Households (FHH) and 40% Male Headed households (MHH) testified that they know about the climate change phenomenon. A proportionate stratified sampling technique was used to collect information on water resources and climate change from households within the study areas. Using a sample frame a sample size of 15% households was drawn from the total target population of 802 households. A large number of residents (73%) cited observation of nature as their source of information on the climate change phenomenon. More than half (58 %) attribute climate change to religious reasons “God’s wish, or God’s punishment due to human being sins”. 30% of the respondents could not explain what causes climate change, and a few respondents (11%) attribute the climate change phenomenon to deforestation, ozone destruction and industrial pollution. The respondents said unanimously that the climate change phenomenon is illustrated by change in rainfall patterns, unpredictability of rainfall patterns, change of seasons, unpredictable decrease/increase of amount of precipitation and periodic dryness. The respondents cited starvation, poverty, water shortage and natural catastrophes (floods, erosion) as the main consequences of the climate change phenomenon. For climate change adaptation the majority of respondents (92%) claimed to have done anti-erosion terraces and planted anti-erosion trees and bushes. Our baseline survey found that some traditional rainwater harvesting is practiced. For example in Kirambi it was found that the traditional rainwater harvesting technique is very poor in both the catchment (roof) and the storage system (no conveyance system such as gutters and conveyance pipes). This practice consists on manually collecting rainwater from roof using small and removable home containers such as pans, drums, bowls and pots. The absence of a conveyance system does not allow the collection of a sufficient amount of rainwater. Mostly households were not aware of the phenomenon storing big volumes of water to be used for an extended period. However, for daily usage, rainwater is stored into domestic containers such as jerricans, pans, pots, bowls and drums. As indicated before, wastewater is not well managed and used except some household which use kitchen waste water for watering pigs and for gardening.

### The catchments

The 9 villages are located in four catchment areas which comprise agricultural land (over 75%), forests (approximately 16%)<sup>146</sup>, human settlements (less than 6%), and water bodies (over 3%). Like most of cases in Rwanda, in these catchments, rainfall is distributed seasonally in two long rainfall periods and 2 short periods. The amount of rainfall collected in these catchments area is big enough for both agriculture and domestic uses. However, for domestic use, rooftops are not big enough and not good quality (poor runoff coefficient) to collect enough volume of water and in some case there is no suitable technique for harvesting. For agriculture purposes, runoff is not well directed and collected in the structures which could keep it in the soil and participate on soil moisture content efficiency. Most of cases where runoff is not well harvested, it causes erosion and therefore environmental degradation. However, some practices such as bench and progressive terracing, tree planting, road canals have been introduced to handle this issue. Human activities such as natural resources exploitation (farming, mining and quarrying, human settlement, deforestation) have caused natural resources degradation when there not well designed. Generally we have identified that there is a presence of green areas (forest and vegetation) in these catchments and there serious regulation for its protection by local authorities exists.

### District Profiles

The relief of Nyanza District is inclined from West to East. Its highest point is in Nyagisozi Sector on Shyunda hill situated at 2,112 meters of altitude. The lowest point is located at 1,300 metres of altitude in the Akanyaru valley. More precisely, the Sectors of Busoro, Muyira, Kigoma, Ntyazo and Kibirizi, are located in the lowest altitudes whereas those of Nyagisozi, Mukingo, Rwabicuma, Cyabakamyi and Busasamana, lie on an altitude between 1,300 and 1,800 metres. Nyanza District is situated within a tropical region and has a humid climate. This region experiences four seasons, two dry seasons from January to February and from July to mid-September and two rainy seasons from September to December and from March to June. The Western part which is mountainous registers relatively low temperatures and plenty of rainfall. The two project villages, Bweru and Mpaza Villages, are located in the

<sup>146</sup> Estimates made using maps and direct field observation (Trocaire , 2015 b)

## RAINWATER HARVESTING & SAND DAMS

### Rainwater Harvesting

western part of Nyanza district , precisely in Kirambi cell of Nyagisozi sector with an altitude ranging between 1550 meters and 1706 meters.

Nyamagabe District has an average altitude varying from 1800 to 2700 meters. It has uneven altitude with some summits at times going beyond 3000 meters high. The altitude and rains increase as and when one approaches Congo-Nile Crater. Nyamagabe District relief is characterized by jagged and irregular slopes ranging from 60° to 120° making soils susceptible to soil erosion and degradation. The climate of Nyamagabe District is humid tropical and moderated by the effect of high altitude. Nyamagabe District is among the regions in the country with the highest rainfall. The annual rainfall varies from 1300 to 1450 mm with average temperature of 18°C. Like Nyanza District the climate comprises four seasons spread throughout the year as follows: two dry seasons stretching from January to February and from July to mid-September and two rainy seasons from mid-September to December and from March to June. The project villages are Gikomero and Gatare villages of Kiyumbo cell in Cyanika sector. The two villages are located in the eastern part of Nyamagabe district with an altitude ranging between 1690 meters and 1910 meters.

The District of Kamonyi lies between 1500 and 2000m of altitude. Its relief is made of low lying plateau, except in the western part which is more mountainous. The District of Kamonyi enjoys a moderate climate. The frequency of rainfall is sufficient and varies between 1.200 and 1.400 mm. The District experiences a short rainy season from September to November and a long rainy season from February to May. The short dry season runs from December to January and the long dry season from June to mid-September. The average temperature is 20°C. The project villages are Rubanga and Nyarusange villages of Karengera cell in Musambira sector. The two villages are located in the western part of Kamonyi district, with an altitude ranging between 1570 meters and 1790 meters.

Recent government water access data is available for each district under the Integrated Household Living Conditions Survey Enquête Intégrale sur les Conditions de Vie des ménages (EICV3) (National Institute of Statistics of Rwanda, 2012). For example Nyamagabe, which is ranked worst in terms of poverty with 73% of its population identified as poor (including extreme-poor), is 17% below the Economic Development and Poverty reduction Strategy (EDPRS) national target requirement for the water and sanitation sector, which aims to increase access to safe drinking water to 85%. The EICV3 results indicate that 68% of Nyamagabe district households use an improved drinking water source (protected springs, public standpipes, water piped into dwelling/yard, boreholes, protected wells and rainwater collection, as defined by the World Health Organisation). In Nyamagabe district the majority of households use protected spring water (51%), followed by a public standpipe (8.5%) and protected well (6.5%). It is important to note that 32% of households still use unimproved water sources. More than a third (36.5%) of households in Nyamagabe district are within 15 minutes' walking distance of an improved water source and it is also important to note that 16% of households still walk 30 minutes and above to reach an improved water source.

Baseline survey in the project areas, found that over 13% households have their nearest source of water at a distance less than 100 meters; 28% households have their nearest source of water between 100 meters and 500 meters, and more than 59% households have their nearest water source at a distance greater than 500 meters. Water sources included groundwater aquifers / springs, wetland/marshland, rivers/streams and limited piped networks before project implementation. Only 7.4% of surveyed households have an improved water source. Rainwater harvesting was introduced at the project's inception (**See Table1: Domestic water sources. Trocaire a, 2015**).

#### **Description of the Approach or technology**

The immediate aim was to address intermittent water shortages, especially during the dry season and to promote the use of rainwater for cropping, especially vegetable production. This will address some of the water shortages caused by climate change and environmental destruction including tree removal and over-cultivation of unprotected slopes. The long-term aim is that water resources are restored, enhanced and well managed by the village communities. This will in turn strengthen the people's resilience to extreme weather conditions.

## RAINWATER HARVESTING & SAND DAMS

### Rainwater Harvesting

A two-pronged approach was taken in which the process of IWRM was introduced to the communities alongside the introduction of rainwater harvesting technologies. The project's overall aim is: *Targeted Male Headed Households (MHHs) and Female Headed Households (FHHs) have resilient livelihoods as a result of increased knowledge and capacity in water resources management, technologies and practices.*

Five project outputs were planned and are underway:-

1. *Households in 9 communities are educated in climate change adaptation practices and planning.*
2. *Roof water harvested and used for vegetable production by 180 FHHs and 120 MHHs.*
3. *Run-off water harvested and used for agricultural production by 182 FHHs and 120 MHHs.*
4. *Household wastewater recycled and used for vegetable production by 110 FHHs and 90 FHHs.*
5. *Climate Change adaptation technologies and practices in 9 communities are documented for internal and external learnings.*

The project activities included the identification of most vulnerable households and groups for runoff ponds; a whole-village water resources survey; a rainwater harvesting survey to match houses and sites to appropriate technologies; community education and organisational skilling about water resources and climate change.

The whole village water resources survey (Trocaire,2015b) profiled the study villages in terms of their demography and economy, climate change adaptation knowledge and attitudes, water resources management practices, agricultural activities and the communities' expectations from the water project. The rainwater survey studied the 406 individual household situations of the most needy households which were identified. It made measurements of their roof sizes (0 to 25m<sup>2</sup>, 25 m<sup>2</sup> to 70 m<sup>2</sup> or over 70 m<sup>2</sup>), their roofing materials (tiled or ironsheet), negative interaction with the surrounding environment (erosion, flooding, structures destruction), availability of rainwater tanks, water need, source of potable water, possible contribution to rainwater harvesting project implementation, accessibility to the site and land suitability for construction. In designing tanks two methods were used the “method of scarcity period” and the “cumulative method”. Seasonal rainfall data and the runoff coefficient, which determines how much water will flow from the catchment surface when it rains and how much gets lost, were used in calculating the potential volumes which could be collected. Potential demand for domestic and irrigation needs were calculated and tank type and size matched to that need. In situations of small tiled roofs where low volumes could be collected, it was decided to provide semi-underground tanks which have their own iron-roofed catchment in order to boost volume collected. Three types of tanks were chosen for individual households semi-underground tank (**Photo 1**), bamboo tank (**Photo 2**) and plastic tank (**Photo 3**). Ferrocement tanks were not chosen because they were as expensive as plastic tanks and could be replaced by bamboo tanks for a much lower cost. Runoff sites were also identified to provide group farms with poly-lined irrigation ponds (**Photo 4**). In total **131** bamboo tanks of 5,000 litres volume, **22** plastic tanks of 5,000 litres volume and **443** semi-underground tanks of 6,000 litres volume were installed at **596** households. Ten poly-lined ponds with 480,000 and 250,000 Liters litres capacity were constructed at cooperatives farms. The project covered all external material costs while the householders and groups contributed labour and local materials. Delivery from the bamboo and plastic tanks is by gravity but various manual/foot pumping systems have been tested for use with the semi-underground tanks and the ponds (**Photo 5**). Community members were trained in construction and maintenance of their technologies and provided with tools for maintenance. Training was also given in gardening (**Photo 6**) using irrigation water.

The community education and organisational skilling components comprised training for Water Field Officers, who would act as facilitators; formation of village level organisations (Village Water and Climate Change Committees (**Photo 7**); participatory landscape vulnerability analysis and mapping; stakeholder analysis and prioritisation of issues and necessary actions. A vulnerability matrix which covered bio-physical and socio-economic risks and threats was framed and used during transect walks and community discussions. (Trocaire, 2015 c) (**Photo 8**).

Village water committees have been supported to keep files about their water resources and about the project. The durable maps, printed by the project, also belong to the villages. Eight communities were

## RAINWATER HARVESTING & SAND DAMS

### Rainwater Harvesting

facilitated to carry out their own Integrated Water Resources Management Planning processes and to make presentations of Village Water Resource Action Plans (*Photo 1 & 4*) and maps to higher level Local Government stakeholders. These community actions plans contain some activities that can be implemented by community without any external help which need a direct collaboration between the community and other external stakeholder and others which need advocacy for fund mobilization.

Guidance manuals were drafted throughout all the processes, including the construction of tanks, performing community water resources planning processes, and are scheduled for publication and wider use throughout Rwanda.

#### Main results and lessons learnt

Nine communities participated and successfully tested the technologies. As a result, 596 households (230 MHHs & 366 FHHs) installed one or two technologies and are now harvesting and storing the rain water for their farming activities, mainly dry season vegetable production. Of those who installed roof rainwater systems, **(a)** 443 Households installed semi-underground tanks technology with 6,000 litres capacity, **(b)** 131 Households installed bamboo tanks technology with 5,000 litres capacity and **(c)** 22 installed plastic tanks technology with 5,000 litres capacity. Additionally, **(d)** 352 Households (215 FHHs & 137) grouped into farmers' cooperatives installed 10 run-off water ponds with 480,000 and 250,000 Liters capacity to irrigate their group plots (14.5 ha). Finally, eight communities have developed village climate change adaptation plans and established Village Water and Climate Change Committees (VWCCs). The VWCCs have presented the findings of their village water resources investigations to higher authorities. Having brought various issues to the attention of the authorities (e.g. broken piped systems, pollution by mining, severe erosion) they have received some immediate responses from higher government. Formal mining has been suspended in one village and budgetary provisions will be made for repairing a piped water system in another village.

Mind-set change has been achieved at both village and higher governance levels. Villagers realise that they have power to change the management of communal water resources and factors affecting them. Higher government has opened its eyes to some very serious problems relating to water resources and are willing to act. Higher authorities are grateful to villagers and to the project for forming and training VWCCs and for making IWRM Action Plans. Higher authorities are very happy at the speed, quantity of infrastructures in place and quality of their installation to promote the rainwater harvesting systems as this is part of the government's plan and priorities.

Participants are making the direct connection between climate change and water resources status. They also recognise direct human impacts which raise or reduce risks to climate hazards. People feel more empowered to do something and that they are not just exposed to a far away abstract concept. Other NGOs have copied technologies in other villages within the same Districts. Local authorities are already in processing of copying all aspects of this pilot project elsewhere in their districts and have included them in their annual action plans. The national government is also interested in copying the project innovations and processes more widely across the country. Examples from Kamonyi District are that the district is going to copy the project in 12 other sectors using the national climate change fund, FONERWA administered by REMA, which receives international donor contributions. The Musambira Sector is interested in the village plans and wants to discuss the responsibility for implementing them and where the resources will come from.

#### Lessons

1. Success was possible because of:-

- Trocaire and partner staffs' openness to the new whole-village, catchment -wide approach. They had previously focussed on on-farm and cooperative activities with individual households selected for their household vulnerability and poverty. This was a new approach which went wider than farm and considered whole village communities and their catchments.
- Strong trusting relationships between the partners and the villagers and between Trocaire and the partners.

## RAINWATER HARVESTING & SAND DAMS

### Rainwater Harvesting

- The placing of water technologists in partner organisations and with responsibility for facilitating only two villages each. The technologists were able to provide day-to-day technical and organisational advice and support to the householders and the village community. This ensured clear understanding and uninterrupted project activity.
  - Excellence and efficiency of engineering and technical teams. Deadlines and targets were met and community time was not wasted. Also trust between the construction contractors and the householders was at a high level because of this efficiency.
  - Use of participatory methodologies which were newly introduced to the field workers and the communities. There is need to provide participatory skills training and guided practice experience to communities, extension workers and NGO managers in Rwanda because such skills are not as widespread in as in other developing countries. Such skills can make a contribution to community cohesion and governance beyond natural resources management.
  - The combination of granting of water technologies simultaneously with the community planning processes. This meant that a large proportion of householders could see immediate results from the rainwater harvesting technologies while being requested to participate in the wider and slower community process of analysing water resources and planning for their management. There is a fund established by the community members in each of 9 villages for the maintenance and reparation of the technologies. Additionally, each village has finalised the action plan toward the climate change adaptation and the implementation of some activities has already started with minor external support.
  - All players, especially villagers, were interested and committed to participating – no sitting allowances involved!
  - Close collaboration with government at village, cell, sector and district levels. Fully transparent collaboration with government is obligatory for NGOs in Rwanda. Done well it leads to government support to and adoption of project innovations. It thus can lead to action above the village level and to elevation of innovation to higher levels, even the national level.
  - Simple local materials and low technology facilitate automatic local adoption. For example four households have copied the semi-underground tank technology without material assistance from the project.
2. When going from a households’ targeting approach to a whole-village approach it was important to explain why the level of benefits varies and to justify the selection of specific households for grants of technology e.g. household vulnerability criteria relating to nutritional insecurity and poverty. The criteria used were those normally for identification of the most vulnerable households in community, including people living with HIV, Child Headed Households, Female Headed Households, elderly, etc.. This is because those who do not get free grants of technology may feel less enthusiastic to engage in community efforts.
  3. Non-confrontational presentation of facts, such as villagers making public presentations of water resources issues through maps and the individual village vulnerability matrices, is an effective advocacy tool in Rwanda. It gives communities a framework for expressing the specific bio-physical and socio-economic risks and threats which they are facing in their particular environments. All villages became more aware of soil erosion and its siltation impacts on the valley bottoms and the water quality. The impacts of mining on the water quality was specifically exposed by one village.
  4. Women gain confidence when given their own space for expression and are then ready to take up leadership and representation roles. Of the 84 committee members, there are more women (47) than men (37) and the women are active and vocal in meetings in the villages and elsewhere.
  5. Better management of water from homes and yards reduces conflict with downslope neighbours. Before the project interventions for rainwater capture there were cases of conflict with downslope neighbours because the runoff from upslope compounds was eroding their land. Once the rainwater harvesting systems were installed the erosion stopped and the conflicts were resolved.
  6. Reasonably cheap rainwater harvesting solutions are available and some technical expertise exists in Rwanda. However, they are not widely disseminated. For example the semi-underground tank building expertise was found in northern Province of Rwanda and the bamboo tank skills are a core capacity within the national NGO ANA. However, these technologies were not available in 9 villages



## RAINWATER HARVESTING & SAND DAMS

### Rainwater Harvesting

- before the project support and this expertise needs to be tapped and funding invested in order to bring it to all rural areas.
7. There is a huge opportunity and need for spreading both the RWH technologies and the Community IWRM methodologies across Rwanda. This has been expressed by senior government officials and gives hope that multiplication of the innovations will be given government support.
  8. Semi-underground tanks can be made more accessible, safer and hygienic by installing simple hand pumps. No pumps were being provided for semi-underground tanks in the northern areas of Rwanda from which this project sourced the construction expertise. Therefore a very simple suction pump for each tank was constructed the first time on site with simple and available material at local level. It is made by telescoping two sizes of pvc piping and inserted into the tank through a wall. **(Photo 3)** Pumping is done from externally, therefore obviating the need to open the tank door and immerse a bucket into the water. This is a new innovation for semi-underground tanks in Rwanda.
  9. Time needs to be dedicated to adaptations and repairs of equipment for the site and the gender needs. For example the pump height in the wall of the semi-underground tank needs to be adjusted to suit the user such as elevation of the pump. Also, in order to avoid spillage, the height of the water spout needs to be set to suit the vessel into which it is to be poured.
  10. The greatest problem in all eight communities is the soil erosion within the farm fields resulting in production losses, gully formation, land slippage and siltation of wetlands. Although this pilot project has identified the problem, further experimentation with solutions to this problem on very small parcels of land with constant (three times per year) cultivation is needed.
  11. There is very high value in engaging communities in water resources analysis and planning. This value supports community cohesion, agricultural production and overall environmental resilience.

### Conclusions and Recommendations

The pilot project has been very successful and there is huge demand by villagers and by local and higher government to replicate the Community IWRM processes and the RWH technologies. In order to do this, much further investment is needed in training for both the community watershed catchment planning processes and the RWH technology installations and maintenance. The government of Rwanda has identified the RWH as an important strategy for the country and recommendations have been formulated in this manner. However, national and district levels should clarify more the roles of Village level committees for water and natural resources management, strengthen their mandate, and commit to providing training to these nationwide committees including in the legal and funding instruments at their disposal. Credit institutions should consider provision of credit for RWH installations and the government and donors should consider such interventions for grants under their Climate Change Adaptation strategies and budgets. Technological interventions should provide budgets and time for experimentation with adaptations which best suit users especially women and girls.

### Mentions

The project was implemented by four local NGOs (COCOF, IPFG, MMM Kirambi & UNICOOPAGI) who have been long-term partners of Trocaire's livelihoods programme. None of the partner organisations had specialist expertise in water and therefore each partner engaged a water technician to guide the project implementation and to provide the technical support to beneficiaries. Further water engineering, hydrological and installation expertise was sourced in Rwanda. Overall project technical and managerial supervision was done by Trocaire which managed the funds contributed by the Scottish Government Climate Justice Fund via the Scottish Catholic International Aid Fund (SCIAF).

### References

- National Institute of Statistics of Rwanda, 2012. EICV3 District Profile South –Nyanza,  
National Institute of Statistics of Rwanda, 2012. EICV3 District Profile South –Kamonyi, ,  
National Institute of Statistics of Rwanda, 2012. EICV3 District Profile South –Nyamagabe,  
Republic of Rwanda, 2011. Ministry of Natural Resources. Water Resources Management I Sub-Sector Strategic Plan (2011 – 2015).

## RAINWATER HARVESTING & SAND DAMS

### Rainwater Harvesting

Trocaire , 2015 a. “Roof and runoff rain water harvesting & Waste Water use: Technologies need assessment in

8 villages of Nyanza, Kamonyi and Nyamagabe Districts” Trocaire. Kigali.

Trocaire, 2015b. Baseline survey on water resources assessment and recommendation. Internal study performed

by SOCOSE Ltd. Trocaire, Kigali.

Trocaire 2015 c (in draft ).Manual for the Preparation of a Community-Based Adaptation Plan with a focus on

Water Resources.

REMA 2015. State of the Environment Report 2015.

World Bank 2013. Rwanda Economic Update- Maintianing Momentum With a special focus on Rwanda’s pathway out of poverty.

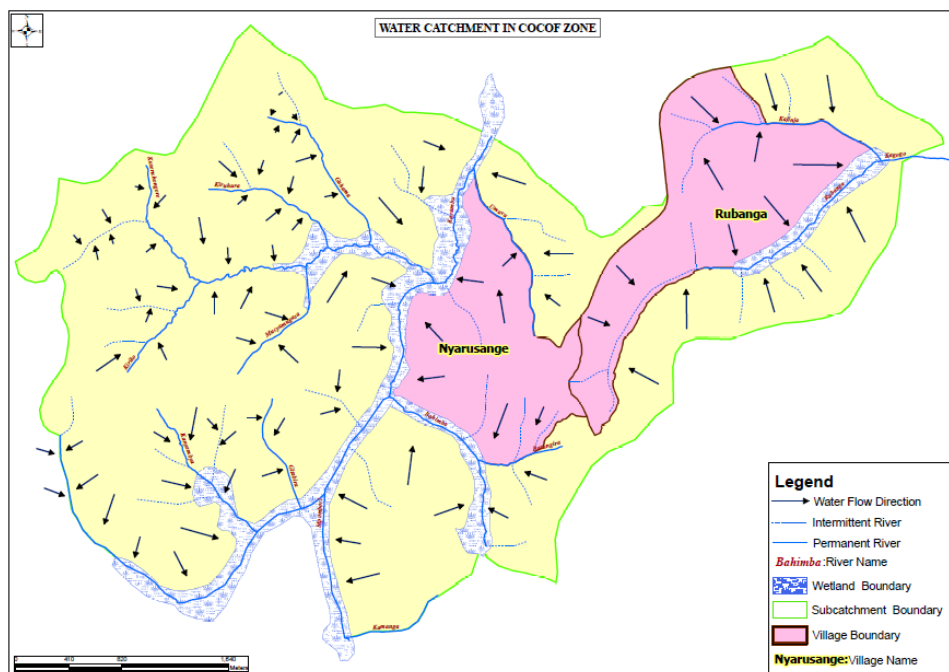

Map 1: Topographical map showing hydrological features in Rubanga & Nyarusange Villages of Kamonyi District.

RAINWATER HARVESTING & SAND DAMS

Rainwater Harvesting

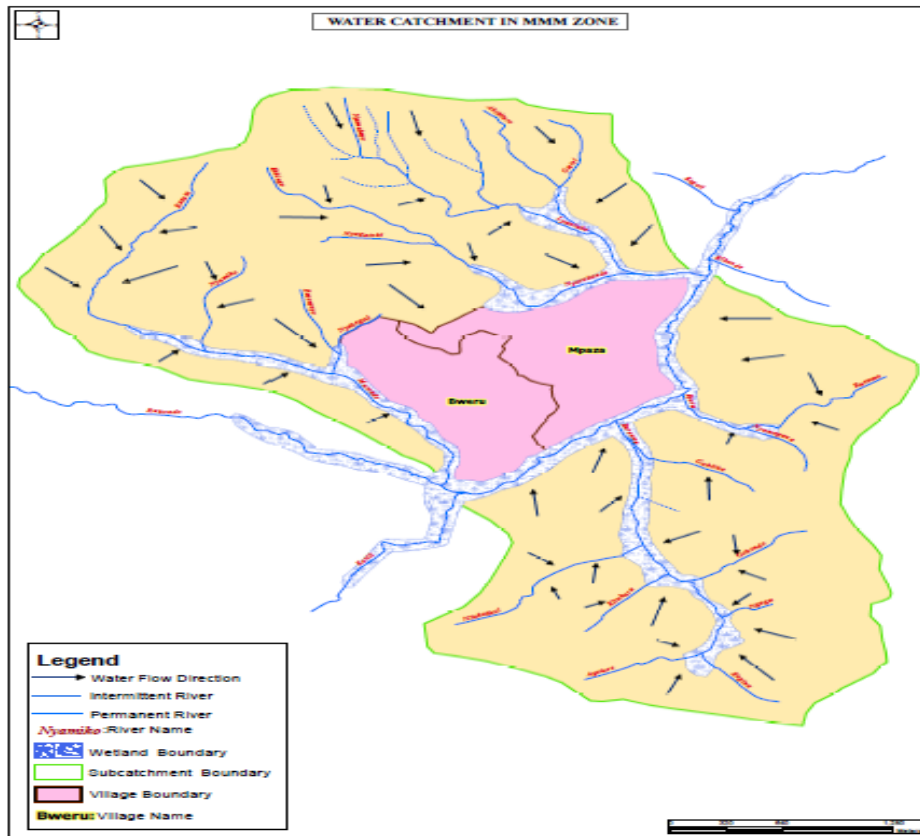

Map 2: Topographical map showing hydrological features in Bweru & Mpaɛza Villages of Nyanza District.

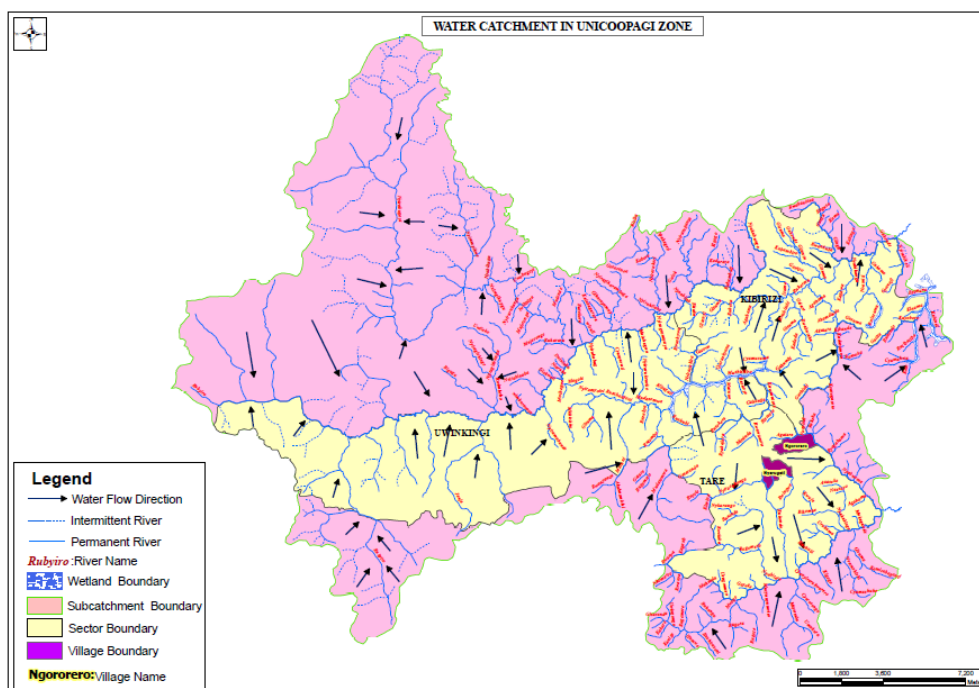

Map 3: Topographical map showing hydrological features in Nyarugeti & Ngororero Villages of Kamonyi District.

RAINWATER HARVESTING & SAND DAMS

Rainwater Harvesting



*Photo 1: Semi under-ground tank technology, Nyanza District.*



*Photo 2: Bamboo tank technology, Kamonyi District*



*Photo 3: Plastic tank technology, Nyanza District*

## RAINWATER HARVESTING & SAND DAMS

### Rainwater Harvesting



*Photo 4: Runoff of Poly-lined pond technology on groups' farms, Nyamagabe District.*



*Photo 6: Gardening following the technical training*



*Photo 7: Training for water field officers in IWRM, Nyanza District*

## RAINWATER HARVESTING & SAND DAMS

### Rainwater Harvesting



Photo 8: Village water committee presenting the findings from the vulnerability analysis/Transect Walk for their village, Nyanza District



Photo 9: Village water committee presenting the village maps and action plans, Kamonyi District.

**Table 1:** Domestic water sources in project geographical areas as per the survey (Trócaire, 2015).

Project geographical area		Water sources					
Villages/Districts	Sample size	Precipitation	Groundwater aquifers / springs	Marshland	Rivers / streams	Network of potable water	
Rubanga and Nyarusange Village in Kamonyi District.	FHHs	13	9	8	6	1	3
	MHHs	10	9	7	6	0	5
Gikomero and Gatare villages in Nyamagabe District	FHHs	14	13	8	10	7	0
	MHHs	10	10	6	9	5	0
Uwinyana & Nyarugeti villages of Nyamagabe District.	FHHs	27	22	21	11	0	1
	MHHs	19	15	16	7	0	0
Bweru and	FHHs	19	19	10	14	11	0

**RAINWATER HARVESTING & SAND DAMS**

**Rainwater Harvesting**

Mpaza villages of Nyanza District.	FHHs	10	10	4	6	7	0
Total in percentage			87,70%	65,57%	56,56%	25,41%	7,38%

## RAINWATER HARVESTING & SAND DAMS

### Rainwater Harvesting

---

# Water Catchment management through a 3R approach- Case of RWAMBU Catchment-Western Uganda

---

Type: Short Paper

**Lead Author;**

**Name;** *Rugumayo Godfrey Mulinda,*

**Position;** *Program Manager, Water and Sanitation,*

**Institution;** *Joint Effort to Save the Environment (JESE),*

**Country;** *Uganda,*

**Email;** [godfrey.mulinda@jese.org](mailto:godfrey.mulinda@jese.org),

**Telephone;** *+256772315433*

**Co-Author**

**Name;** *Patrick Baguma,*

**Position;** *Team Leader,*

**Institution;** *Joint Effort to Save the Environment (JESE),*

**Country;** *Uganda,*

**Email;** [jpbaguma@jese.org](mailto:jpbaguma@jese.org),

**Telephone;** *+256772492109*

### Abstract/Summary

This paper demonstrates a case in which environmental landscaping through a 3-R approach which is an acronym for Retention, Recharge and Reuse can result into regeneration and restoration of ground water resources and increasing access to water whilst improving the natural environment. This landscaping was done on the Rwambu catchment a trans-boundary water catchment bordering the districts of Kamwenge and Ibanda in Western Uganda; it's made up of a wetland situated in the valley and surrounding hilly areas. The 3R approach in essence is to manage natural recharge and to store water within the landscape so that it becomes usable in periods of water scarcity. This is done via: **Recharge i.e** optimizing the infiltration of rainfall and runoff water and improving groundwater recharge for example by planting trees, **Retention i.e** keeping water in the area and slowing down the outflow, for example by creating stone barriers and **Reuse i.e** making the recharged and retained water available for consumption, production or ecologic services, for example through recycling water multiple times.

Rwambu catchment is faced a multiplicity of ecological challenges, uphill of the wetland there is visible soil loss through erosion/surface run off and lack of viable sources of water given that the water table dropped drastically. The existing water sources mainly shallow-wells and boreholes were drying rapidly, in the downstream there was high rate of water contamination as a result of surface run off from poorly constructed and maintained pit latrines and open defecation in the rocky uphill around the wetland. The wetland itself was under constant threat of encroachment by the nearby community for purposes of agriculture and settlement. JESE in partnership with Rain Foundation, Kamwenge district local government and the local community piloted out a 4 year (2012-2015) environmental landscaping and sustainability program that emphasises integrating 3R approach (recharge, retention and reuse) and wetland management in a catchment and placing WASH interventions in the wider context of the natural environment and implementing an approach of integrated and sustainable management of water and waste(-water) flows and resources. The program was implemented in the Rwambu catchment, a trans boundary wetland covering the districts of Kamwenge and Ibanda Districts in Western Uganda. It was implemented in 5 communities and the wetland covers 5kilometres in stretch. A total of 300 households/1200 people (small holder farmers) participated and benefited in this program.

### Introduction



## RAINWATER HARVESTING & SAND DAMS

### Rainwater Harvesting

Uganda's “National Policy for the Conservation and Management of Wetland Resources” was launched in 1995 to promote the protection of Uganda's wetlands in order to sustain their ecological and socioeconomic functions. Despite the formal policy, wetlands continue to be drained and converted. However, a policy is only the first step in successful environmental management. In order for a policy to become a reality, it must be implemented.

In Uganda wetlands cover 13% of Uganda's surface area<sup>147</sup>; Wetlands are an integral part of Uganda's geography and constitute an important resource for development. Their ecological functions include the maintenance of the water table, prevention of erosion, flood control, micro-climate regulation, toxin retention, sediment traps and water purification. Wetlands provide habitats for wildlife, notably waterfowl. In addition, wetlands help regulate the micro-climate. Wetlands also provide socio-economic benefits to the community. Plant products, such as papyrus, are used for handcrafts and roof thatching. Wetlands provide: fish for consumption and sale, clean water and grass for cattle-grazing, areas for beekeeping, sitatunga (waterbuck) for hunting, and opportunities for tourist enterprises. Wetlands contribute to the nation's health by purifying water. In rural areas, the economic valuation of this natural water purification is approximately US\$25 million a year<sup>148</sup>.

This short paper introduces a case in which local environmental landscaping approaches piloted on Rwambu wetland in Western Uganda resulted into regeneration and restoration of ground water resources as well as a general appreciation of the importance of wetland resources to the social economic wellbeing of the community surrounding the wetland.

#### **Context, aims and activities undertaken**

Initially, JESE commissioned an investigation purposed to have a better insight into the hydrological balance in the area, relevant socio-economic aspects, such as population size, local income generating activities, water needs and access to WASH, this helped design and develop appropriate technologies, structures and interventions.

JESE facilitated the building of cascade check dams, valley dams and sand/stone bands to control water run-off. The bands help reduce on evaporation and retain soil moisture. Bands were placed in vicinity of the boreholes to check evaporation as to allow the water to sink into the ground for recharging. As a result boreholes that had dried have been put back to functioning through reparation and in combination with increased water table in the area, they are now serving water to the community around the catchment. The borehole management has been let out to an entrepreneur as a water as a business initiative.

JESE has also promoted multiple use of water through construction of cattle troughs and tapping run-off water from constructed water points. Because of the rocky nature of the landscape, JESE piloted the construction and use of ecological sanitation as an option to controlling surface and underground water contamination. We also constructed fanya ju's and Fanya chini's to prevent run off and retain soil moisture with in banana and coffee plantations.

To avert sustained encroachment of the Rwambu wetland, JESE facilitated a process of demarcating the wetland through consultation and participation of the local community and the local government. 15 meters from wetland were reserved as a buffer zone and all households affected by the zoning exercise were compensated with alternative livelihood options; in this case they were granted environmental friendly enterprises such as zero grazing cows, fish ponds, coffee and bee hives. At the uphill, JESE engaged the community to plant environmental friendly tree to act as carbon sinks as well as holding soils against uncontrolled erosion.

#### **Main results, outputs and lessons**

---

<sup>147</sup> Sector performance report ministry of water & environment 2014

<sup>148</sup> Enhancing Wetlands' Contribution to Growth, Employment and Prosperity in Uganda, Environment and natural resources series report, UNDP 2009

## RAINWATER HARVESTING & SAND DAMS

### Rainwater Harvesting

- Regeneration of the catchment boundaries that had been encroached upon, 5Km of Rwambu wetland restored and demarcated,
- Restoration of the ecological functions of the Rwambu Wetland, animal such as monkeys and rare birds have regained their habitats. 12 different species of birds, 3 species of monkeys have returned to the wetland,
- The water table is stabilising, and the water recharge rate for boreholes and shallow wells in adequate as evidenced increase in water table for shallow well in Kinagamukono village from 37m to 34.6m (2.4 m rise), yield at 0.51m<sup>3</sup>/hr, draw down at 21.51m, dynamic water level after 120 minutes at 56.40m.
- Promotion of environmental friendly enterprises has boosted household incomes and improved livelihoods. As a result of the empowered communities, 04 wetland management groups have established commercially viable apiary units of 100 bee hives, a 1000 m<sup>2</sup> fish pond with a carrying capacity of 2000 catfish and 1000 tilapia fish, coffee cultivation and heifer project for diary milk production.
- Incidences of crop failure due to prolonged droughts have reduced as a result of improved soil moisture. From field testimonies, it was seen that in-situ water harvesting caused a 40 – 66 % increase in crop yields and productivity.

### Pictorial;

1. **Increased water table:** This borehole in question was rehabilitated after so many years of non functionality due to low water tables. The 3R approach was integrated to Retain and Recharge water upstream so that it could be Re-used downstream. Indeed monitoring tests showed an increment of about 1.6m depth in ground water tables! The borehole that had never pumped water for years, now supplies the community with water throughout the year. This technology created employment for the caretaker who is paid 10% of the proceeds, O&M Improved and community started perceiving water as an economic good. When this borehole is compared to a similar one about 10km away, the other one still dries up at some seasons of the year. If this case is taken as a control, it is a sure way to think that the 3R interventions are a success for Rwambu



**Pic 1: Recharged Borehole**

2. **Stone lines:** This labor intensive intervention is worth the effort. The once abandoned infertile land regained its productivity. Communities which had resorted to encroaching on the wetland in search for fertile land downstream, once again started cultivating on their previously infertile hill slopes. This intervention checks soil erosion and improves soil depth by creating “soil benches” allowing time for water Retention and Recharge.

## RAINWATER HARVESTING & SAND DAMS

### Rainwater Harvesting



**Pic 2: Stone Piles**

3. **Fanya chini:** Fanya Chini” is a word from the Kiswahili dialect to mean “working down” This intervention is best suited in steep slopes. The soil dug from the trench is thrown on the lower side of the slope as opposed to its counterpart “fanya juu” to mean working up which is best suited in gentler slopes where the soil is dug and thrown up hill. Both are intended to check the speed of runoff and hence increase water Retention and Recharge.



**Pic 3: Fanya Chini**

4. **Check dams:** This is a more permanent structure built of stone and concrete-the check dam. It was constructed to close up the V-shaped Gully that was created as a result of an advanced stage of soil erosion. Aside rehabilitating degraded hill slopes, it also reduces the speed of runoff hence, increasing water Retention and therefore encouraging water Recharge.



**Pic 4: Check Dams**

### Key Lessons:

- Water recharge is long term and difficult to predict, this sometimes discouraged community participation however, through various 3R trainings, the community came to appreciate the benefits of recharge to their water needs for both domestic and agricultural production.

## RAINWATER HARVESTING & SAND DAMS

### Rainwater Harvesting

- During project implementation, it was learnt that community members are dynamic once sensitized about an intervention and its advantages. They are willing to adopt, for example the willingness to take up the pay as you fetch model on their water points as way of sustaining them using the collected fees, the use of available stones to construct stone bunds for soil conservation, the excavation of a fish pond to boost their household incomes and the construction of a community access bridge to ease communication and enhance development.

### Conclusions and Recommendations

Its possible to implement wetland related laws, but this should be done in comprehensive and participatory manner and developing sustainable solutions that addresses community's social and economic needs.

### Acknowledgements

*Joint Efforts to Save the Environment (JESE) as a lead facilitator of this process,  
Rain and wetland international for funding the project of Rwambu-e-sustainability,  
The local government of Kamwenge District in western Uganda,  
The community and local leaders around Rwambu Wetland,*

### References

<http://www.washalliance.nl/2014/08/26/uganda-commits-to-providing-safe-drinking-water;>  
[www.jese.org;](http://www.jese.org;)  
<http://www.rainbowcollection.eu/rain-best-practice/index.php?practice;>

## RAINWATER HARVESTING & SAND DAMS

### Sand Dams

#### 3.6.2 Sand Dams

---

# Mainstreaming Water Security through Rainwater Harvesting (Sand dam)

---

Type: **Short Paper**

**Author:** Gloria Berochan  
Senior Programme Coordinator, Rural Water, Sanitation and Hygiene  
WaterAid Uganda  
**Contact:** [GloriaBerochan@wateraid.org](mailto:GloriaBerochan@wateraid.org)  
+ 256-773-303992  
+ 256-759-389610

### Abstract / Summary

In Uganda, the rural population accounts for 82% (28.4million) of the Country's total population (34.8 million). The rural water coverage has stagnated for over five years at 65%. This has been attributed to inadequate technologies to reach those in water stressed areas. The project's targeted district of Napak has water coverage of 59.83%. The district population is predominantly pastoralist in a semi-arid region and affected by a mix of disasters ranging from long spell drought, floods and water insecurity. WaterAid demonstrated a Sand dam technology in Napak district (Karamoja sub-region). This has increased water security for the vulnerable people in eleven villages. To achieve this, a wide range of comprehensive activities were implemented prior to the introduction of the dam; community water needs assessment, feasibility studies, learning visits, stakeholders' dialogues, Community involvement and capacity building. Our recommendation to the sector is to explore major innovations in technologies in order to achieve human right to water.

### Introduction

Uganda is challenged with uneven spatial and temporal distribution of its fresh water resources coupled with the ever increasing pressure on the limited resource due to rapid population growth, uncontrolled environmental degradation and pollution. This affects sustainable management and development of the country's fresh water resources. The country has for over years witnessed declined in water levels and also increased water treatment costs. There are considerable variations in the onset of rain seasons as well as significant differences between wet and dry years.

Data from the National Census 2014 provided by Uganda Bureau of Statistics (UBOS) indicates that the population of Uganda by August 2014 was 34.8 million. 28.4 million (82%) are living in rural areas. The national rural water coverage has stagnated for over five years at only 65%<sup>149</sup>. The stagnation is contributed by inappropriate technologies to reach the population especially those settling in water stressed areas and also to meet the competing demand coupled with the increasing population growth. Service fails most often due to high pressure on the limited resources. Majority of the population (35%) with no access to safe water are residing in areas characterized as water stressed.

The year 2003 saw significant advances in the development of the Sector wide approach focussing on water for production and water resources management. But deciding where to invest which technology, how to develop services in an integrated manner has been a challenge requiring data, analysis and successful demonstrations like sand dams.

---

<sup>149</sup> Sector performance report, 2015, Ministry of Water and Environment

## RAINWATER HARVESTING & SAND DAMS

### Sand Dams

Sand dams are “*partially subsurface dam build in a dry and sandy riverbed onto bedrock or an impermeable layer. It is constructed across a river to block the subsurface flow of water, hence creating a reservoir upstream of the dam within the riverbed Material*<sup>150</sup>”. The reservoir is filled due to percolation of water during flood events. The water within the riverbed stands out for both domestic use and livestock especially during dry seasons. Hence, providing water security for the different water users and building resilience to climate change.

### Context, aims and activities undertaken

The sub-region targeted by this project (Karamoja) is a semi-arid region. Karamoja sub-region has seven districts (Napak, Nakapiripirit, Moroto, Amudat, Abim, Kotido, and Kaabong) with a total population of 988,149 people (478,672 male and 509,477 females)<sup>151</sup>. The population is predominantly pastoralists. The Communities that reside in the sub-region practice small-scale agriculture and livestock farming. Over the past years, the sub-region has experienced a reduction in productivity yields, declined water levels, long drought leading to drying up of some water sources, floods and deteriorating water quality. The sub-region has perennial rivers and with rainfall varying highly, both spatially and temporally, water dries up quickly after the seasonal rains, leaving few sources of water pressurized. The current situation in which there is, perpetually growing water demands and competition from different water users is leading to deepen water insecurity in the region. The situation calls for innovative way of harvesting water during rainy season.

It is in this context that, WaterAid implemented a Sand dam (demonstration) technology in Napak district in Karamoja. The district's total Population was 145,219 people (69,086 males and 76,133 females)<sup>3</sup>, the water coverage stands at 59.83% which is lower than the National Coverage of 65%. The sector has been largely investing in point water sources (Boreholes). The depth of boreholes drilled in district ranges from 70m-120m against an average depth of 60m in Uganda. This implies that, the ground water table in the district is low and service fails shortly. The functionality rate is at only 78% again lower than the National figure of 88%. Experience has showed that Boreholes (Hand pumps) are not very technically feasible for sustained water service in such areas. Provision of structures which increase water security for the vulnerable groups residing in water stressed and hard to reach areas has been a challenge. Hence, the need for Water professionals to play an important role in exploring other technological options to build resilience and improve access to water for the different water users. Water being a fundamental right.

### Aims

The project was aimed at improving water security for vulnerable people living in post conflict affected areas. These areas previously suffered from insurgencies and are recovering from wars, IDP camps (internally displaced persons)

### Activities and how they were done

The project applied a demand responsive approach and supported a comprehensive package of activities as seen below.

**Feasibility study:** The feasibility study was not only limited to technical (technology) aspect but focused on the wider elements beyond pure technical feasibility i.e. PESTLE Analysis (Political, Economic, Social, Technical, Legal and Environmental). The study found out that, there was bedrock near the river bed; the River sediment largely had fine sand and low silt content in some areas. However, there was evidence that this would not affect the ability to abstract water from scoop holes. Interview with the communities suggested that there were high flows during rainy seasons. The community water needs were for domestic, livestock and food production. There was a strong cultural need to appease the ancestral spirits before introduction of the sand dams. It was also clear that the Council of Elders was the most appropriate entry point into the communities. One area we identified as being critical was ensuring the project processes differentiate between ‘community consultation and participation’ and true community

<sup>150</sup> Manual on Sand dam construction by Ethiopian rainwater harvesting association

<sup>151</sup> Uganda Bureau of Statistics (UBOS) census report, August 2014

## RAINWATER HARVESTING & SAND DAMS

### Sand Dams

ownership. Overall, the study established that, the sand dam technology was very effective in the sub-region.

**Stakeholders' learning visit:** To enhance stakeholders' capacity to design, construct and manage the technology, WaterAid did a learning journey in 2013 to ASDF (African Sand Dam Foundation) in Kenya involving the key stakeholders from the government and partners to implement a sand dam demonstration project. Following the visit, series of engagement and dialogue were held with political wing, Social and Water Professionals, and local leaders (Elders). As a cultural requirement, the community sacrificed a white he-goat to appease the ancestral spirits as a way to cleanse the construction site. These then led to a buy-in at all levels. However, where knowledge and capacity already exists one may not need to consider learning visits but rather utilize and manage the knowledge.

**Community involvement:** The local communities actively participated in site selection, provision of local materials and labour. This was very critical to insight sense of ownership in the communities but also to enhance local capacity which is vital for sustainability.

**Technical Supervision:** Intensive technical supervision was provided during designs, site selection and in constructing other key dam components such as the basement, spillway, foundation ensuring adequate strength and diversion of flow, retention /wing walls to withstand the longitudinal load exerted by both the water and sand was another area for key attention.

### Main results and lessons learnt

Before interventions, communities testified of over flooding from Omaniman River and there was no Rainwater harvesting of any kind, limited access to water especially during dry season, communities and animals could share water from the same point, migration and loss of lives in the rivers as a result of high flows during rainy seasons. Today, the stories are totally different;

- **Evidence of plan to up-scale the innovation by the Government of Uganda:** A learning journey was held by Directorate of Water Resources Management, Technical support Unit of Ministry of Water and Environment and the Napak District Water supply Coordination committee (the sector) on the sand dam. Reports from the different visits concluded that the sand dam project was successful. This led to incorporation of the technology in Awoja catchment management (Government) plan for wider uptake.
- **Increased water access for domestic, livestock and food production:** The dam has a storage capacity of about 10,000m<sup>3</sup> and has increased access to water to eleven villages with a population of 3,245 people. During dry seasons, the communities now have access to water for domestic use, livestock and food production. Since the dam construction, local farmers have been irrigating crops using water from the shallow well. This saves especially women and girls' times to other productive activities including school attendance. .
- **Increased Water reliability,** All the Community members(women and men) interviewed said they now have water throughout the year as opposed to the one month retention period before the dam was constructed.
- **Increased Water levels:** The water table has risen and as a result water availability has increased. This is supported by the presence of water within the river sediment at a depth of half a meter compared to the 3m water level during the dam's construction.
- **Permanent settlement:** Majority of the men and women interviewed, testified of significant reduction in migration in search of water especially during dry seasons. This is because there is assured water in the dry season; people no longer migrate to other places in search of water.
- **Significant reduction in water speed;** the construction of the sand dam has slowed the flow of water in the river and saved both human and animals' lives. “Previously, livestock and people used to die crossing the river each rainy season which is not the case now” voices from the community members.

### Lessons learnt;

## RAINWATER HARVESTING & SAND DAMS

### Sand Dams

We learnt a couple of lessons from this project. some of these include;

- When introducing a new technology in a community it's important to respect their cultures and beliefs to get social acceptance. In this case, the community buy-in was sought after sacrificing a white he-goat to appease the ancestral spirits.
- The involvement of key stakeholders<sup>152</sup> in both project design and implementation is very vital for the success of the project. Additionally, ensuring the project processes differentiate between 'community consultation and participation' and true community ownership is very critical.
- Enabling environment attributed to positive response and embracement of the Project by the Community and District Local Government was very key for the achievement
- Appropriate site selection is the most vital for the sand dam technical sustainability.

Illustration of voices of the beneficiary community members

### Conclusions and Recommendations

In conclusion, Sand dams need not to be viewed only as a means of extending improved drinking water coverage as they may add more value by taking the strain off existing water supply interventions thereby bringing about sustained coverage rather than extended coverage. Water harvesting is crucial for communities with long dry spells, seasonal rains, and low ground water potential but also for building resilience to climate change. In this way, sand dams are a more appropriate source for achieving equity and inclusion in such context.

We therefore recommend that; Water professionals should examine collectively the entire range of elements, needs and to design innovations which respects the human right to water and other competing and complimentary water needs as these are critical for sustained service. Specifically to this;

- Sand dam is an appropriate solution for areas with seasonal channel rivers, low ground water potential as the dams are aquifer re-chargers.
- To introduce sand dams, significant buy-in has to be sought from political leaders, professionals and community members.
- Appropriate sites for the sand dam should consider both technical and social aspects. These include;
  - ✓ Real demand from the community for water for production and domestic use as well
  - ✓ Best constructed where there is a tradition of mass community participation in construction but also provision of local materials and labour. This creates a sense of ownership.
  - ✓ Proximity to communities where water will be used
  - ✓ Sites where the bedrock is at or close to the river bed are preferred since this keeps construction costs to a minimum.
  - ✓ There should be Coarse sand grand sediment
  - ✓ Large dimensions and high flows during rainy season, facilitating big storage.
  - ✓ Low silt content.
- The technology requires intensive supervision during construction of the basement, foundation, spillway, retention /wing walls to withstand the longitudinal load exerted by Water and the Sand. The spillways should be designed to accommodate the peak floods and the annual floods.
- It is also important to take into account the impact of sand deposition onto the flood plain as this reduces its water holding capacity. This can be done by introducing contour bunds which helps to deposit the sediment more evenly.

### Acknowledgements

---

<sup>152</sup> Government, CSOs, communities and private sector



## RAINWATER HARVESTING & SAND DAMS

### Sand Dams

We do acknowledge the contribution from the following stakeholders;

- European Union (EU-Water Facility) for the financial support
- Napak District Local Government for provision of enabling environment
- The beneficiary community members for contributing materials and taking charge of Operation and Maintenance.
- The Programme support unit of WaterAid-UK for technical support and African Sand Dam Foundation, Kenya for allowing us learn from them.

### References

*Manual on Sand dam construction by Ethiopian rainwater harvesting association*

*Napak District annual report, 2015.*

*Feasibility studies report, WaterAid*

*Ministry of water and environment sector performance reports, 2015*

*Awoja Catchment Management plan, 2015 - Ministry of Water and Environment*

### Annex 1: What communities say



**Lomoe Peter** 48 years old a resident of Lomuria village, Lopeei parish tells how the sand dam is transforming human and livestock lives in the community. “I was there from the beginning and I took part in the construction of the dam. Most people in my village had never seen this technology and many were not supportive at the beginning because they believed River Omaniman was sold, others were worried that the river would dry up because it would annoy the ancestral spirits”. It really took serious discussion with the elders to make them understand how sand dams work and how beneficial it will be to the community.

After sacrificing a white he-goat to appease the ancestors, the elders accepted the construction to commence and many people (men and women) from the village participated in the construction,” says Lomoe Peter.

“Today, the story is totally different, the sand dam has become the darling of the village, and we no longer have any fears that the dam will dry our river. We have also come up with a local name for the sand dam technology -“Ethimit” which can be loosely translated as the “Cement of the bridge.” All people in the community and nearby villages appreciate this technology because they know it keeps water beneath the sand throughout the dry season.

## RAINWATER HARVESTING & SAND DAMS

### Sand Dams

Before the dam was constructed, the river was made up of big rocks, there was no sand to cover these big stones. Today, one side of the river is full of sand which store water in the rainy season for use in the dry season. We used to dig deep to reach water, today its just half a metre. The sand dam is very good; we did not have any water problems for both our homes and animals in the previous dry season. Because there is assured water in the dry season, people no longer migrate to other places in search for water.

The dam has also reduced the speed of water, people and animals used to die in the river during raining seasons. Today, we have not heard any one dying after the construction. In the dry season people have started growing vegetables on the banks of the river to sell in the market for an income.”

**Nicholas Lomilo 61, Parish Chief of Lopeei had this to say:**

“During construction of the dam I held the role of supervision and monitoring the construction. Before, it would take only one month of dry season for the river to run out of water. People and animals used to migrate in search for water, however this time the river has provided us with water kept below the sand throughout the dry season. We are now able to access water from the dam during dry season. We do not allow animals to drink from the same point where we get water for domestic use but rather from troughs by the side. People no longer have to live with fears of no access to water because they have seen the goodness of the sand dam.”

**Nawogo Jacob 70 years,** “Water from the sand dam is safe for drinking because it has already been distilled. My wish is to raise the wall so that more sand is protected from going to the other side of the river.”



**Adeun Madelena, 35,** a mother of six

## RAINWATER HARVESTING & SAND DAMS

### Sand Dams



“This dry season we did not have to migrate anywhere in search of water. We could just make shallow scoops in the sand and water came. This dry season, I planted some vegetables by the banks of the river to eat at home as well as sell in the market for an income. We use the water from the sand dam for cooking, feeding our livestock and even drinking because it is safe, already distilled by sand.”

*Iriama Robert, 68*, a father of 20 children, married with four wives



“The construction of the sand dam on our river has slowed the flow of water in the river. Before, livestock and people used to die crossing the river each rainy season, since the dam construction, we have not heard of anyone who died in the river. The speedy running water used to carry all the sand along with it and we could see the river bedrock all the time. Now the river has accumulated sand which stores water for use during dry seasons.”

## RAINWATER HARVESTING & SAND DAMS

### Sand Dams

# Practical recommendations to prevent, restore and rehabilitate silted-up sand storage dams in arid and semi-arid areas

Type: Long Paper

### Authors

De Trincheria, Josep\*; Wibbing, Jan; Leal Filho, Walter; Otterpohl, Ralf

\*PhD candidate

Hamburg University of Technology, Hamburg, Germany

josepm.trincheria@gmail.com

Tel.: +49-40-42875-6107

### Abstract

Siltation dramatically reduces the performance, cost-efficiency and positive impacts of sand storage dams and it is affecting thousands of sand reservoirs in arid and semi-arid areas. Therefore, the main goal of this study was to showcase scientifically-based practical strategies that can systematically reduce the number of silted-up sand storage dams. In order to minimise siltation, a multi-stage spillway construction process is always strictly required. This is crucial to successfully replicate, transfer and upscale this technology to other arid and semi-arid areas. The stage height should be designed on a case-by-case basis by analysing historical bedload transport over a multi-year period. If this is not feasible, it is recommended to use a range of precautionary fixed stage heights from 20 cm to 60 cm on a case-by-case basis. These stage heights are applicable to all arid and semi-arid regions due to the inherent inter- and intra-annual variability of the bedload transport in these areas. In addition, the large reported shares of silted-up sand storage dams makes relevant that attention is focused on desilting these reservoirs by means of mechanical and hydraulic techniques. Further, silted-up sand storage dams can be cost-effectively rehabilitated for riverbed and/or riverbank reclamation activities.

### 1. Introduction

A sand storage dam is an artificial sand reservoir on a seasonal sandy riverbed in arid and semi-arid areas. The key working principle of this rural water supply technology revolves around maximising the exclusive accumulation of the coarsest grain-size sediments in the runoff (i.e. bedload). This is meant to create a deposit of high-permeability sediments that can continuously fulfil the water needs of local communities during dry periods.

If a sand storage dam performs optimally, it has high potential to benefit rural communities, and therefore, to contribute to food security and poverty alleviation in arid and semi-arid areas (Lasage et al., 2008). Thus, the water yielded by a sand storage dam can be used for domestic purposes and livestock during the dry season, while a smaller share can usually also be used for small-scale irrigation and/or other income-generating activities (Hut et al., 2008). In addition, sand storage dams also offer other benefits, like reduction of evaporation losses (Wipplinger, 1958; Hellwig, 1973) and production of significant volumes of high-quality water (Hut et al., 2008) at low costs (Lasage and Verburg, 2015), among others.

Sand storage dams have been implemented in arid and semi-arid areas at a global level, with a special predominance in sub-Saharan Africa. Kenya has been a hot spot for the implementation of sand storage dams and shows by far the highest implementation rate globally (Viducich, 2015). Sand storage dams originated as a counter-technology to surface dams in order to specifically avoid the characteristic siltation problems associated with open-surface storage of water in arid and semi-arid areas (Wipplinger, 1958). Yet, estimates suggest that siltation may be affecting between 40-60% of sand storage dams implemented in arid and semi-arid areas (Viducich, 2015; De Trincheria et al., 2016). Siltation is caused by the

## RAINWATER HARVESTING & SAND DAMS

### Sand Dams

accumulation of large volumes of low-permeability fine grain-size sediments in the reservoir (Fan and Morris, 1992; Brandt, 1999; Stephens, 2010) and dramatically reduces the performance, cost-efficiency, and associated multi-dimensional benefits of sand storage dams (Wipplinger, 1958; Nissen-Petersen, 2011; De Trincheria et al., 2015, 2016). In addition, silted-up reservoirs present high vulnerability to evaporation (Wipplinger, 1958; Hellwig, 1973) and are unable to meet local community needs during dry periods (De Trincheria et al., 2015, 2016).

Nissen-Petersen (2011) and De Trincheria et al. (2015, 2016) argued that the major cause for siltation in sand storage dams is associated to the design of the spillway. Currently, the final spillway height of most sand storage dams, which is usually between 1-5 m, is built in one stage. Due to the stage height and the high inter- and intra-annual variability of the bedload transport in arid and semi-arid areas, the one-stage spillway design has an inherent high vulnerability to accumulate large volumes of fine grain-size sediments which are transported as part of the suspended load in the runoff, and therefore induce the siltation of the reservoir. The universal replication of this design across arid and semi-arid areas implies that the large number of silted-up sand storage dams in Kenya may be highly representative of other arid and semi-arid areas.

While alternative spillway designs which minimise siltation have been in existence at least since the 1950s (Wipplinger, 1958; Baurne, 1984; Nilsson, 1988; Nissen-Petersen, 2000, 2006, 2011; Ochieng et al., 2008; De Trincheria et al., 2015, 2016), there is currently no consensus on a universal design to systematically minimise siltation in sand storage dams. In addition, the estimated high shares of silted-up sand storage dams in arid and semi-arid areas imply that there may be thousands of silted-up reservoirs globally (Viducich, 2015). However, there is currently no strategy in place to systematically restore or rehabilitate silted-up sand storage dams.

## 2. Aims

The main goal of this study was to showcase scientifically-based practical recommendations that can systematically reduce the number of silted-up sand storage dams in arid and semi-arid areas. In order to achieve this goal, the following specific objectives were pursued:

- To analyse the engineering and hydrogeological factors that cause siltation in sand storage dams.
- To showcase practical strategies that can systematically minimise siltation.
- To showcase practical strategies to restore silted-up sand storage dams.
- To showcase practical strategies to rehabilitate silted-up sand storage dams for riverbed and riverbank reclamation activities.

The methodology of this study coupled the lessons learnt from a hydrogeological evaluation of 45 sand storage dams in Kenya and Zimbabwe with an exhaustive and comprehensive review of relevant scientific literature.

## 3. Main results

### 3.1 Engineering and hydrogeological factors that cause siltation in sand storage dams

#### **3.1.1 Sand storage dams are vulnerable to siltation**

Runoff transports eroded materials that deposit when the flow energy cannot continue transporting them. After the construction of a sand storage dam, the flow energy will decrease behind the spillway and the capability of the water flow to carry sediments will also decrease (Wipplinger, 1958; Brandt, 1999). Thus, Wipplinger (1958) proved that the spillway height of a sand storage dam increased the deposition of fine grain-size sediments behind the spillway. Therefore, the spillway of sand storage dams acts as sediment traps, as any other spillway of a conventional surface reservoir, because it interrupts fluvial sediment transport and allows inflowing solids to deposit (Fan and Morris, 1992). In addition, high levels of erosion are ubiquitous and characterised by a strong dominance of fine-grained material fluxes (i.e.

## RAINWATER HARVESTING & SAND DAMS

### Sand Dams

suspended load) in arid and semi-arid areas (Alexandrov et al., 2009; Billi, 2011). Thus, Powell et al. (1996) and Alexandrov et al. (2009) found that bedload transport accounts for a minimum portion (5-8%) of the total sediments transported in the runoff in different multi-year record analyses. Therefore, without adequate measures to balance the inflow of coarse grain-size sediments with the outflow of fine grain-size sediments, sand storage dams are inherently vulnerable to accumulate large volumes of fine grain-size sediments, and eventually face siltation (Fan and Morris, 1992). Figure 1 shows a silted-up sand storage dam and a small-scale sand reservoir.

### 3.1.2 The high variability of bedload transport increases the vulnerability to siltation

Powell et al. (1996), Alexandrov et al. (2003, 2009), Cantalice et al. (2013) and Lucia et al. (2013) clearly showed that bedload transport in arid and semi-arid regions is highly variable, both for individual storms, and for seasonal and/or annual totals. Furthermore, bedload transport is highly scattered due to the existence of unrecognised miniature bedforms, which contribute to the high spatial variability of the bedload flux (Lucia et al., 2013). Also, the clear trend towards increased variability of rainfall events in sub-Saharan Africa (Pachauri et al., 2014) may further exacerbate the variability of the bedload transport. Low-energy runoff events and/or temporal low-intensity flow energy conditions during a specific runoff event produce bedload transport rates which are very low or inexistent inter- and intra-annually. Thus, Alexandrov et al. (2009) and Powell et al. (1996) proved that bedload transport depended on a well-defined entrainment threshold. That is, when the intensity of the flow does not reach this minimum threshold, the bedload yield tends to be zero and the flood transports only suspended sediments, which happened in 1 out of 3 runoff events evaluated in several multi-year record analyses (Powell et al., 1996; Alexandrov et al., 2009). In addition, Reid and Frostick (2011) found that runoff generally consists of only fine grain-size sediments during the last stages of flood flows. Further, Gichuki (2000) found that 40-60% of the years on a decadal scale are poor rainfall years in arid and semi-arid areas, which may increase the frequency of low-intensity runoffs and low bedload transport rates (Wipplinger, 1958).



**Figure 1:** A successful small-scale sand storage dam (left) and a silted-up reservoir (right), in Kenya.

### 3.2 Practical recommendations to systematically minimise siltation in sand storage dams

#### 3.2.1 The spillway should always be raised by stages of reduced height

As has been previously mentioned, the bedload transport is highly variable and often inexistent inter- and intra-annually in arid and semi-arid areas corresponding to a minority fraction of the total sediment yield. In addition, the height of the spillway increases the deposition of fine grain-size sediments in the reservoir. These hydrogeological arguments are also true for sites with the geological potential to produce coarse sand sediments (Alexandrov et al., 2003, 2009; Lucia et al., 2013). Therefore, the lower the stage height, the lower the vulnerability to siltation, and the higher the probability to maximise the exclusive accumulation of the bedload transport. Thus, a multi-stage construction process, with stages of reduced height, maximises performance, cost-efficiency and positive impacts across many different environmental settings and/or in spite of the variability of rainfall, runoff and bedload transport in arid and semi-arid areas (De Trinchieria et al., 2015, 2016).

## RAINWATER HARVESTING & SAND DAMS

### Sand Dams

In addition, to build by stages of reduced height maximises the accumulation of the coarsest sediments in the runoff during low-intensity rainfall, runoff and sediment transport conditions, and also in sites with low geological potential to produce sand sediments (De Trinchieria et al., 2015, 2016). This is because the low height of the spillway regularly allows flow energies which are high enough to maximise the exclusive deposition of the bedload transport. This increases the number of suitable sites where sand storage dams can perform optimally, thereby providing a strategic advantage. On the contrary, by increasing the stage height, the natural capacity of a suitable site to perform optimally is reduced since the flow energy behind the spillway regularly allows the deposition of volumes of fine grain-size sediments which would otherwise not occur naturally.

Further, the velocity and height from which runoff falls is reduced using a multi-stage spillway design, which prevents scour and undercutting of the wall that may lead to damage of the dam wall (Hussey, 2007). Also, this construction process allows monitoring and evaluation of the reservoir's performance on a regular basis, both between stages and at the end of the construction process. Thus, corrective measures can be implemented in order to ensure maximisation of performance and lifetime of the sand storage dam depending on rainfall, runoff and sediment transport conditions during the filling up of the reservoir.

According to Nissen-Petersen (2006) and Viducich (2015), the most cost-efficient method to raise the spillway by stages is to initially construct the underground section and wing walls to their final height, and only raise a smaller part of the dam in the centre of the channel in order to subsequently raise the spillway stage by stage. Figure 2 illustrates this process in Kenya. In addition, further research is required to assess the suitability and effects on the stage height and total construction time with regard to the use of V-shaped or rectangular notches (Baurne, 1984), siphons (Wipplinger, 1958) and flushing devices on the spillway (Viducich, 2015).



**Figure 2:** A sand storage dam was raised 3m in 6 stages of 0.50 m in one rainy season, in Kenya. Source: (Nissen-Petersen, 2006).

### 3.2.2 Reasons for the predominance of one-stage sand storage dams

Building by stages of reduced height has been proposed by several authors at least since the late 1950s (Wipplinger, 1958; Baurne, 1984; Nilsson, 1988; Nissen-Petersen, 2000, 2006; Ochieng et al., 2008; De Trinchieria et al., 2015, 2016). However, there is currently an absolute predominance of sand storage dams built in one stage. This may be due to a combination of lack of adequate understanding of the benefits and disadvantages of building by stages (Viducich, 2015), misconceptions with regard to the factors affecting the performance of one-stage sand storage dams, which have been analysed by De Trinchieria et al. (2015), and the donor-dependency of self-funded implementing agencies, which dictates to show successful results within short reporting periods so as to be able to effectively finance current and future activities (De Trinchieria et al., 2015; Viducich, 2015).

### 3.2.3 Determining the stage height on a case-by-case basis by analysing historical bedload transport

## RAINWATER HARVESTING & SAND DAMS

### Sand Dams

To determine a stage height that can systematically minimise siltation at the same time as the exclusive accumulation of the coarsest sediments in the runoff is maximised, in spite of the bedload transport variability, is the most challenging design criteria of a multi-stage sand storage dam. Ideally, the best possible practice is to determine the specific stage height on a case-by-case basis through a long-term analysis of the bedload transport. This is to obtain the minimum and average historical flux of sand sediments in a specific site. In addition, this should be coupled with the predicted incidence and magnitude of rainfall, runoff and sediment transport during the construction process, and empirical information with regard to the historical magnitude and incidence of rainfall and runoff from local communities (De Trincheria et al., 2015). Practically, however, to be able to ascertain accurately these variables with certainty is almost impossible (Alexandrov et al., 2009). In addition, the data collected should reflect a multi-year period in order to be valid. Yet, this data is often lacking in arid and semi-arid areas (Billi, 2011), which increases the complexity, high-costs and time required to obtain this information (Cantalice et al., 2003; Lucia et al., 2013). Thus, further research is required to develop a simple and low-cost methodology which can accurately predict on a case-by-case basis the historical bedload transport of seasonal rivers in arid and semi-arid areas.

#### 3.2.4 Using precautionary fixed stage heights on a case-by-case basis

If it is not feasible to carry out a multi-year analysis of the bedload transport in a specific site, this study proposes to use a range of fixed stage heights from 20 cm to 60 cm on a case-by-case basis. These heights have been obtained from relevant literature focusing on long-term scientific and empirical analysis of sedimentation in sand storage dams in arid and semi-arid areas (Wipplinger, 1958; Nissen-Petersen, 2000, 2006, 2011; Ochieng et al., 2008).

The range of proposed fixed stage heights are given in Table 1 and the methodology to use them on a case-by-case basis is further elaborated in Figure 3. The recommendations take into account key hydrogeological variables which have the strongest influence on the bedload transport in arid and semi-arid areas, and the total construction time of the final spillway. Among others, the predominant particle grain-size of the original riverbed and artificial sand reservoir, and the number of rainfall events during the wet season. In addition, the recommendations also take into account some trade-offs between the stage height and the vulnerability to siltation which can be considered if the total construction time of the final spillway height is higher than the project period. However, the main objective of this methodology is to maximise performance, cost-efficiency and positive impacts in as many different environmental settings as possible and/or in spite of the variability in bedload transport inter- and intra-annually. Thus, even though the stage heights may be conservative under some conditions or imply total construction times higher than expected, the vulnerability to siltation is always minimised.

Stage heights of 20 cm are generally recommended for ephemeral streams because under conservative assumptions final spillway heights between 1.5 and 5 m can be raised in 1-3 years for unimodal rainfall seasons during good and/or normal rainfall years (Table 2). Therefore, there is no need to increase the vulnerability to siltation because the total construction time is within conventional project cycles of 3-5 years (Viducich, 2015), as it may not be the case under some circumstances for intermittent streams. In any case, as increasing the stage height necessarily implies a higher vulnerability to siltation, it is always recommended to use a stage height of 20 cm if this stage facilitates reaching the required final spillway height within the project period. If this is not possible, higher stage heights can be used according to Table 1 and Figure 3, but always accepting a higher vulnerability to siltation and risk of failure. In this regard, it is always recommended to use the lowest stage height of the given ranges.

In addition, due to the high risk of siltation, and the corresponding effects on the stage height and total construction time, to build a sand storage dam during poor rainfall years should be avoided, if possible. In sites where there is a predominant presence of fine grain-size particles (i.e. silty and clayey sediments) and/or during exceptionally poor rainfall years or droughts, the construction of a sand storage dam should not take place under any circumstance because it is not possible to satisfactorily minimise the risk of siltation.



## RAINWATER HARVESTING & SAND DAMS

### Sand Dams

**Table 1: Recommended stage heights to be used on a case-by-case basis:** CA= Predominant particle grain-size of the original riverbed (C=Coarse, M=Medium, F= Fine); R= Type of seasonal river (I=Intermittent, i.e. continuous flow of water during wet periods; E=Ephemeral, i.e. flow of water only after a rainfall event); S= Number of rainy seasons/year; GR= Predominant particle grain-size of the reservoir created by the sand storage dam; H= Height of stage height in exceptionally good, good and normal rainfall years (m); H(P)= H during poor rainfall years (m).

#	CA	R	S	GR	H	H(P)
1	C	I	1	C,M	0.3-0.5	0.2
2	C	I	1	F	0.6	0.3
3	M	I	1	M	0.3	0.2
4	M	I	1	F	0.6	0.3
5	F	I	1	F	0.2	0.2
6	C	I	2	C, M	0.3-0.5	0.2
7	C	I	2	F	0.6	0.3
8	M	I	2	M	0.3	0.2
9	M	I	2	F	0.6	0.3
10	F	I	2	F	0.2	0.2
11	C	E	1	C	0.2-0.3	0.2
12	C	E	1	F,M	0.3	0.3
13	M	E	1	M	0.2	0.2
14	M	E	1	F	0.3	0.3
15	F	E	1	F	0.2	0.2
16	C	E	2	C	0.2-0.3	0.2
17	C	E	2	F,M	0.3	0.3
18	M	E	2	M	0.2	0.2
19	M	E	2	F	0.3	0.3
20	F	E	2	F	0.2	0.2

Prior to the design of the stage height, some considerations are always strictly required in order to maximise the cost-efficiency of a water supply intervention that is based on a seasonal sandy riverbed. Thus, if the natural capacity of the riverbed suffices to adequately meet the water needs of the beneficiaries, to build a sand storage dam is not cost-efficient. Instead, the intervention and investment should be redirected to improve the water access of the beneficiaries by means of upgraded water abstraction systems from the original sand reservoir (Nissen-Petersen, 2006; Hussey, 2007). Similarly, if the natural capacity of the riverbed is not satisfactory but the implementation of a subsurface dam suffices to meet the water needs of the local communities, implementing a sand storage dam is not cost-efficient. In addition, due to its underground position, subsurface dams are robust to siltation, and show a higher lifespan and lower construction costs than sand storage dams (Nissen-Petersen, 2014; De Trinchieria et al., 2015).

### 3.2.5 Recommendations to minimise constraints associated to building by stages of reduced height

Viducich (2015) stated that the main disadvantages of a multi-stage sand storage dam are that the total construction time is significantly higher than the conventional 3- or 5-year project cycles, higher costs and materials, and difficulties to mobilise local communities. In addition, Wipplinger (1958) points out the increased time required for development and a reduced infiltration capacity of the reservoir. Below some considerations and recommendations:

- **Total construction time**

Even though the time required to reach the final spillway is obviously higher than one-stage sand storage dams, the conventional total construction time for a multi-stage sand storage dam is within

## RAINWATER HARVESTING & SAND DAMS

### Sand Dams

conventional project cycles. In fact, with the exception of intermittent streams with a unimodal rainfall season, a maximum construction period between 1 to 5 years would be enough to reach any final spillway height which is generally used in one-stage sand storage dams (cases 6-20, Table 2). Thus, a minimum 5-year project cycle should be advocated with donor agencies. The systematic minimisation of the vulnerability to siltation coupled with the universalisation of optimal performance levels, cost-efficiency and positive impacts to local communities, and the possibility to include a multi-year monitoring and evaluation of the sand reservoir, should serve as good catalysts.

For intermittent streams under a unimodal rainfall season (cases 1-5, Table 2), a final spillway height between 1.5-3 m is conservatively estimated to be reached in 5 years. However, even in these cases, this should not always necessarily be an issue. Thus, the final spillway height of a sand storage dam should not only be designed on the basis of what is technically and economically feasible, but also taking into account the actual water needs of the beneficiaries and the original water yield capacity of the riverbed. When these factors are taken into account, the maximum spillway height that is able to satisfy local communities may be lower than 1.5-3 m in many cases. Thus, sand storage dams with spillway heights between 0.5-3 m have been found to fulfil local community needs, especially if other key performance factors different than the spillway height are also taken into account (Nissen-Petersen, 2006; De Trincheria et al., 2015; Nissen-Petersen and De Trincheria, 2015).

If it is not possible to reach a final spillway height that meets local communities within the project period, the project cycle should be accordingly increased. If this is not possible, the site should not be considered suitable as it is not possible to ensure that the reservoir will not become silted-up, and therefore, to invest in a failed sand storage dam that does not meet local community needs and/or performs deficiently.

#### ▪ Construction costs

Viducich (2015) stated that a multi-stage spillway sand storage dam entails higher costs as a result of the transport costs for materials and personnel, and the need to use more concrete between stages. However, most of the materials and human resources are used at one time, as it is the case for one-stage sand storage dams, because the underground section and the wing walls do not have to be built by stages. In addition, the materials to raise the spillway do not necessarily need to be transported several times to the construction site and can be stored in a safe place nearby the site, like a government building. Furthermore, as implementing agencies usually work in several projects per year, the transport costs for personnel can be covered as part of these activities. Also, these costs could be included as part of monitoring and evaluation activities of the performance of the sand storage dam during the project period.

The costs for the extra concrete are negligible as compared to the total construction costs of the sand storage dam, and it is always better to bear these costs rather than invest in a silted-up reservoir which does not yield water. In this regard, De Trincheria et al. (2015) and Nissen-Petersen and De Trincheria (2015) give practical recommendations to reduce the conventional capital investment costs of a sand storage dam. If these recommendations are taken into account, a multi-stage spillway construction process can be less expensive than building in one stage using current construction procedures.

**Table 2: Time required for development of the final spillway height in a multi-stage sand storage dam:** EG= Exceptionally good rainfall years, G= Good and normal rainfall years, P=Poor rainfall years; R= Type of seasonal river (I=Intermittent, E=Ephemeral); S= Number of rainy seasons/year; ER= Runoff events which can be used to raise one stage; H/y= Maximum height of the spillway in 1 year (m), H/3y= H in 3 years (m), H/5y= H in 5 years (m). The calculations are made with the lowest H in the range (Table 1).

#	R	S	ER(EG)	H/y	H/3y	H/5y	ER(G)	H/y	H/3y	H/5y	ER(P)	H/y	H/3y	H/5y
---	---	---	--------	-----	------	------	-------	-----	------	------	-------	-----	------	------

## RAINWATER HARVESTING & SAND DAMS

### Sand Dams

				(EG)	(EG)	(EG)		(G)	(G)	(G)		(P)	(P)	(P)
1	I	1	1	0.3	0.9	1.5	1	0.3	0.9	1.5	1	0.2	0.6	1
2	I	1	1	0.6	1.8	3	1	0.6	1.8	3	1	0.3	0.9	1.5
3	I	1	1	0.3	0.9	1.5	1	0.3	0.9	1.5	1	0.2	0.6	1
4	I	1	1	0.6	1.8	3	1	0.6	1.8	3	1	0.3	0.9	1.5
5	I	1	1	0.2	0.6	1	1	0.2	0.6	1	1	0.2	0.6	1
6	I	2	2	0.6	1.8	3	2	0.6	1.8	3	2	0.4	1.2	2
7	I	2	2	1.2	3.6	6	2	1.2	3.6	6	2	0.6	1.8	3
8	I	2	2	0.6	1.8	3	2	0.6	1.8	3	2	0.4	1.2	2
9	I	2	2	1.2	3.6	6	2	1.2	3.6	6	2	0.6	1.8	3
10	I	2	2	0.4	1.2	2	2	0.4	1.2	2	2	0.4	1.2	2
11	E	1	12	2.4	7.2	12	8	1.6	4.8	8	4	0.8	2.4	4
12	E	1	12	3.6	10.8	18	8	2.4	7.2	12	4	1.2	3.6	6
13	E	1	12	2.4	7.2	12	8	1.6	4.8	8	4	0.8	2.4	4
14	E	1	12	3.6	10.8	18	8	2.4	7.2	12	4	1.2	3.6	6
15	E	1	12	2.4	7.2	12	8	1.6	4.8	8	4	0.8	2.4	4
16	E	2	18	3.6	10.8	18	12	2.4	7.2	12	4	0.8	2.4	4
17	E	2	18	5.4	16.2	27	12	3.6	10.8	18	4	1.2	3.6	6
18	E	2	18	3.6	10.8	18	12	2.4	7.2	12	4	0.8	2.4	4
19	E	2	18	5.4	16.2	27	12	3.6	10.8	18	4	1.2	3.6	6
20	E	2	18	3.6	10.8	18	12	2.4	7.2	12	4	0.8	2.4	4

#### Community mobilisation during wet periods

Viducich (2015) stated that it is difficult to mobilise local communities multiples times for the same project, especially if the benefits are not immediately apparent. However, by adequately informing local communities the benefits of building by stages, this involvement can be catalysed. In addition, taking into account the underground section of the sand reservoir, a sand storage dam can produce apparent benefits since the first stage. In this regard, there are several examples in Kenya and Zimbabwe which illustrate that successfully involving local communities in a multi-stage sand storage dam is possible. In cases where there are severe problems to mobilise local communities, the spillway should be raised using 1 or 2 paid-skilled workers, or the sand storage dam should not be implemented at all.

#### Reduced infiltration capacity of the reservoir

Wipplinger (1958) stated that floods pass over the sand reservoir without sufficient absorption. As sites with predominant fine sand sediments will be more severely affected by this as a result of their low hydraulic conductivity, these sites should be considered to have low suitability (De Trinchieria et al., 2015). In addition, stage heights between 0.2 m and 0.3 m should always be prioritised, so as to maximise the accumulation of coarse and medium sand sediments in the reservoir. Further, as soon as the final spillway height is reached, smart-agroforestry systems coupled with integrated water and soil conservation practices should be implemented in order to increase the retention of floodwater (section 3.4.3).

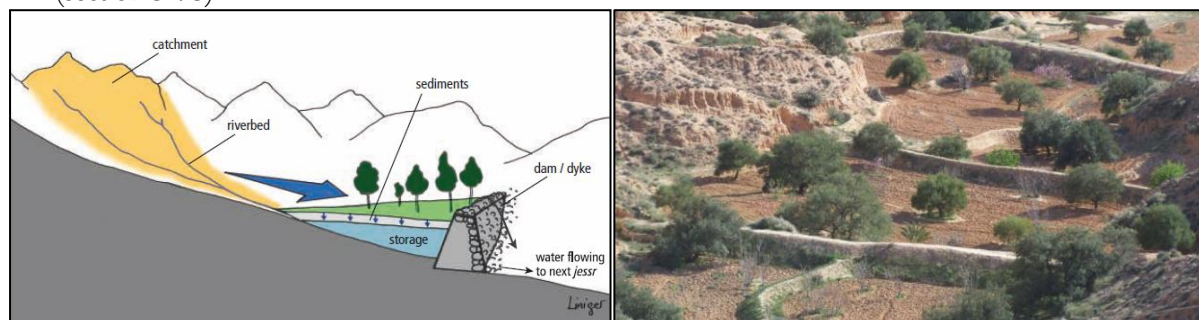

Figure 3: Practical recommendations to use a fixed stage height on a case-by-case basis.

## RAINWATER HARVESTING & SAND DAMS

### Sand Dams

#### 3.3. Practical recommendations to restore silted-up sand storage dams

The water yield and supply capacity of a silted-up sand storage dam can be restored through removal of previously accumulated sediments using hydraulic and/or mechanical desilting techniques. The desilting activities are to be connected with new accumulation of sand sediments during prospective wet periods following a multi-stage spillway construction process. Even though building a new sand storage dam may be more economic and/or simpler than removing the deposited material (Wipplinger, 1958; Qian, 1982 cited in Brandt, 1999), the large number of silted-up sand storage dams (section 1), the declining inventory and high specificity of suitable sites for sand storage dams (De Trinchieria et al., 2015, 2016), and cases where the maintenance of the sand reservoir is imperative, make it inefficient and/or increasingly difficult to replace silted-up reservoirs by implementing new sand storage dams (Fan and Morris, 1992). Therefore, it is relevant that attention is focused on restoring silted-up reservoirs.

Hydraulic flushing allows to remobilize, scour and flush out previously deposited sediments until the reservoir is washed up (Fan and Morris, 1992). In order to do so, the spillway needs to be totally or partially removed. In the latter case, by making a V-shaped or rectangular notch (Baurne, 1984). Thus, the water flow during wet periods is used to erode previously deposited materials (Brandt, 1999). This method shows a high suitability for the restoration of silted-up sand storage dams because it is the cheapest way to desilt a reservoir (Brandt, 1999) and shows high efficiency in small reservoirs (Fan and Morris, 1992). In addition, floods in arid and semi-arid areas have regularly strong erosive energy (Billi, 2011), which may accelerate the washing up of the reservoir. However, the efficiency of flushing is dependent on the reservoir morphology and the characteristics of the flow and deposited sediments (Brandt, 1999). In addition, a specific challenge for silted-up sand storage dams is the large tractive force required to re-entrain dry clayey and silty layers (Brandt, 1999). Other options of hydraulic flushing show low potential for silted-up sand storage dams because of their technical complexity and high costs (Brandt, 1999).

Dredging is a mechanical desilting method that can be used as an alternative or complement to hydraulic flushing (Morris and Fan, 1997 cited in Brandt, 1999). Especially, because flushing may not always solve all sediment-related problems (Morris and Fan, 1997 cited in Brandt, 1999). Dredging can be implemented using manual labour but requires a substantial amount of time and effort (Fan and Morris, 1992). A strategic advantage is that the sediments dredged can be reused for agricultural and construction purposes. Alternatively, making good use of the effect of silting can be to build a new multi-stage sand storage dam on top of the silted-up reservoir (Wipplinger, 1958). However, in order to minimise seepage losses, a layer of at least 1 m of fine grain-size sediments with specific yield lower than 1% would be required.

#### 3.4 Practical recommendations to rehabilitate silted-up sand storage dams for riverbed and/or riverbank reclamation activities

##### **3.4.1 Agricultural and land reclamation potential of silted-up sand storage dams**

Riverbed and/or riverbank reclamation activities for the cultivation of high-value annual or seasonal crops and multi-functional trees can produce significant yields and economic benefits (Studer and Liniger, 2013). In addition, it allows the development of pasture and/or forest land (Studer and Liniger, 2013).

Silted-up sand storage dams have an inherent potential for holistic agricultural and land reclamation activities. This is because the reservoirs have accumulated large fractions of the total sediment yield that is transported in the runoff, which would otherwise have not been accumulated. In addition, these sediments can also include organic materials like leaves and branches. This organic matter can increase humus levels and enhance the biological activity and fertility of the soil (Bot and Benites, 2005). In addition, this is complemented with large volumes of runoff which are regularly available during wet periods. However, flooding and high water flow velocities, as well as periodic water logging of the soil, can harm any agricultural system which is not specifically adapted to these circumstances. Further, the reclamation activities will benefit from the reduction of the gradient of the original riverbed, and the

## RAINWATER HARVESTING & SAND DAMS

### Sand Dams

associated reduction of the flood energy and erosion, which is caused by the accumulation of sediments behind the spillway (De Trincheria et al., 2015).

Another key advantage is to redirect the failed investment in a silted-up sand storage dam towards the implementation of riverbed and/or riverbank reclamation activities. This can decrease the capital investment costs of the reclamation activities, since the structural basis of the interventions has already been facilitated as a result of the construction of the spillway, wing walls and the underground section of the silted-up sand storage dam, as shown in Figure 4.

#### 3.4.2 Riverbed reclamation activities

The low permeability of the sediments accumulated in a silted-up reservoir may not allow for a cost-efficient water supply during the dry season. However, the water fraction that is stored in these sediments coupled with a higher infiltration of floodwater during the rainy season, which is caused by the reduction of the riverbed slope, can be used to support the growth of trees, bushes or fodder crops on the riverbed. In addition, the sediments accumulated may contribute to an increase in the fertility of the riverbed, and therefore, allow planting high-value fruit trees and/or crops under smart-agroforestry systems. This is a good opportunity to tap into regularly available floodwater and the accumulated sediments in the silted-up reservoir so as to carry out agricultural activities on the riverbed, at the same time that erosion downstream can be partially controlled (Studer and Liniger, 2013). However, this type of activities should be coupled with other integrated water and soil conservation practices in order to enhance the agricultural potential of the silted-up reservoir (section 3.4.3). Several technologies and practices to reclaim the riverbed for agriculture are already in use in arid and semi-arid areas (e.g. jessours in Tunisia and gavias in loess plateau of China) (Figure 4).

**Figure 4:** Schematic diagram of the working principles of riverbed reclamation (left) and jessours in Tunisia (right). Source: (Studer and Liniger, 2013).

#### 3.4.3 Enhancement of the agricultural potential of silted-up sand storage dams

The agricultural potential of the sediments accumulated by a silted-up sand storage dam can be enhanced through smart-agroforestry activities. Thus, through careful selection and management of matching perennial plants, the water availability and fertility of the sediments accumulated in the reservoir can be enhanced while erosion is effectively controlled (Young, 1989; Ramachandran Nair, 1993). In addition, from the increased water retention by perennial trees and grasses, which further reduces water flow velocities, and therefore surface runoff and ultimately soil erosion, follows an enhancement of the water availability for crops and trees in the riverbed and riverbanks (Liniger et al., 2011).

Further, deep rooting trees and grasses arranged along the contour line of the reservoir slope and against the water flow can serve for multiple beneficial functions (Gutteridge and Shelton, 1998). Thus, the introduction of adequate deep rooting crop plants and trees have the potential to improve the percolation capacity of the reservoir because their roots can contribute to breaking the compacted sediment layers of the silted-up reservoir (Nichols, 2008). In addition, by using plants or trees with spacious root systems, the silted-up reservoir can also be stabilised horizontally (Daynes et al., 2012). Furthermore, due to litter fall and root decay, the organic matter of the reservoir can be increased. From that follows an increase of the biological activity in the silted-up reservoir, which enhances the decomposition of organic matter and therefore, can facilitate the formation of fertile humus (Bot and Benites, 2005). The activated biological activity in the silted-up reservoir can further contribute to the mixture of sediment layers along the thickness of the reservoir by bioturbation, leaving voids open for improved soil respiration and higher water infiltration rates (Ruiz et al., 2015).

In addition, the permanent canopy of trees can shade the interspace, preventing extreme temperatures, UV radiation and sealing of the top soil, which can benefit plant growth and also the biological activity of the soil and its fertility (Liniger et al., 2011). Further, wind velocities can be effectively reduced using tree rows or hedgerows of plants, which can decrease evaporation rates of the residual floodwater in the silted-up reservoir (Liniger et al., 2011).

## RAINWATER HARVESTING & SAND DAMS

### Sand Dams

Plants resistant to drought and waterlogging should be used for the establishment of the agroforestry system on the riverbed. Easy cultivation by stem cuttings or root splitting should be favoured in order to increase the speed of implementation and shorten transition times (Liniger and Critchley, 2007). In addition, soil fertility can also be increased by the fixation of nitrogen which is carried out by leguminous plants (Palm, 1995; Liniger et al., 2011). This type of plants can also be used as substitute for artificial nitrogen fertilizer (Palm, 1995). Among others, *Gliricidia sepium*, *Sesbania sesban* and *Sesbania grandiflora* are fast growing pioneer trees resistant to water logging which may show a high suitability in a silted-up sand storage dam (Gutteridge and Shelton, 1998). In addition, *Chrysopogon zizanioides* (syn. *Vetiveria zizanioides*), which is commonly known as Vetiver grass, is resistant to drought and water logging as well as suitable for intercropping as a deep rooting fodder grass (Truong, 2000). Further, plants and trees can be cut regularly in an integrated crop-livestock management system such as silvopasture (Liniger et al., 2011), in which livestock animals feed on the cuttings of trees and the pasture in the field, and leave their manure to further fertilize the silted-up reservoir and close nutrient cycles (Liniger et al., 2011).

Tree rows which are intercropped with ground covering grasses along the contour line of the slope of the riverbed and in orthogonal direction to the water flow can act as a physical barrier to slow down water flow velocities. Thereby, enhancing the storage of floodwater for agricultural purposes. Thus, through specific arrangements of alternating tree rows supported by stones, runoff can be directed into a meandering state in order to increase water retention and simultaneously reduce erosion, as shown in Figure 5. Hence, the runoff water storage capacity of the silted-up reservoir and the water availability for agricultural purposes can be further increased.

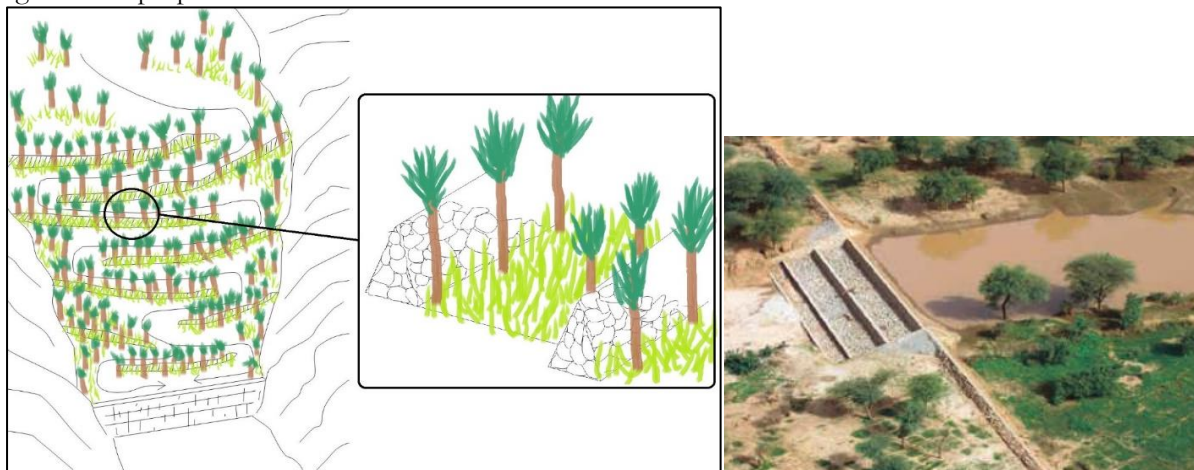

Figure 5: Alternating rows of trees and grasses supported by stone walls can cause the runoff to meander.

### 3.4.4 Riverbank reclamation activities

A potential rehabilitation of silted-up sand storage dams can be in the form of water spreading weirs for spate irrigation in areas with low riverbanks, or after the corresponding extension of the spillway and the wing walls in areas with higher riverbanks. In this regard, Studer and Liniger (2013) state that water spreading weirs slow the water flow and increase the area which is regularly flooded. Thus, crops and pasture growing on the riverbanks along ephemeral riverbeds could profit from flooding and make use of residual moisture after flood retreat (Studer and Liniger, 2013). As the structural basis of a silted-up sand storage dam already spans the entire width of the riverbed and part of the riverbanks by means of the spillway and wing walls, runoff can be spread over the adjacent riverbank area with little intervention. Figure 6 shows a water spreading weir in Chad.

RAINWATER HARVESTING & SAND DAMS

Sand Dams

Figure 6: A water spreading weir in Chad: Source: (Studer and Liniger, 2013).

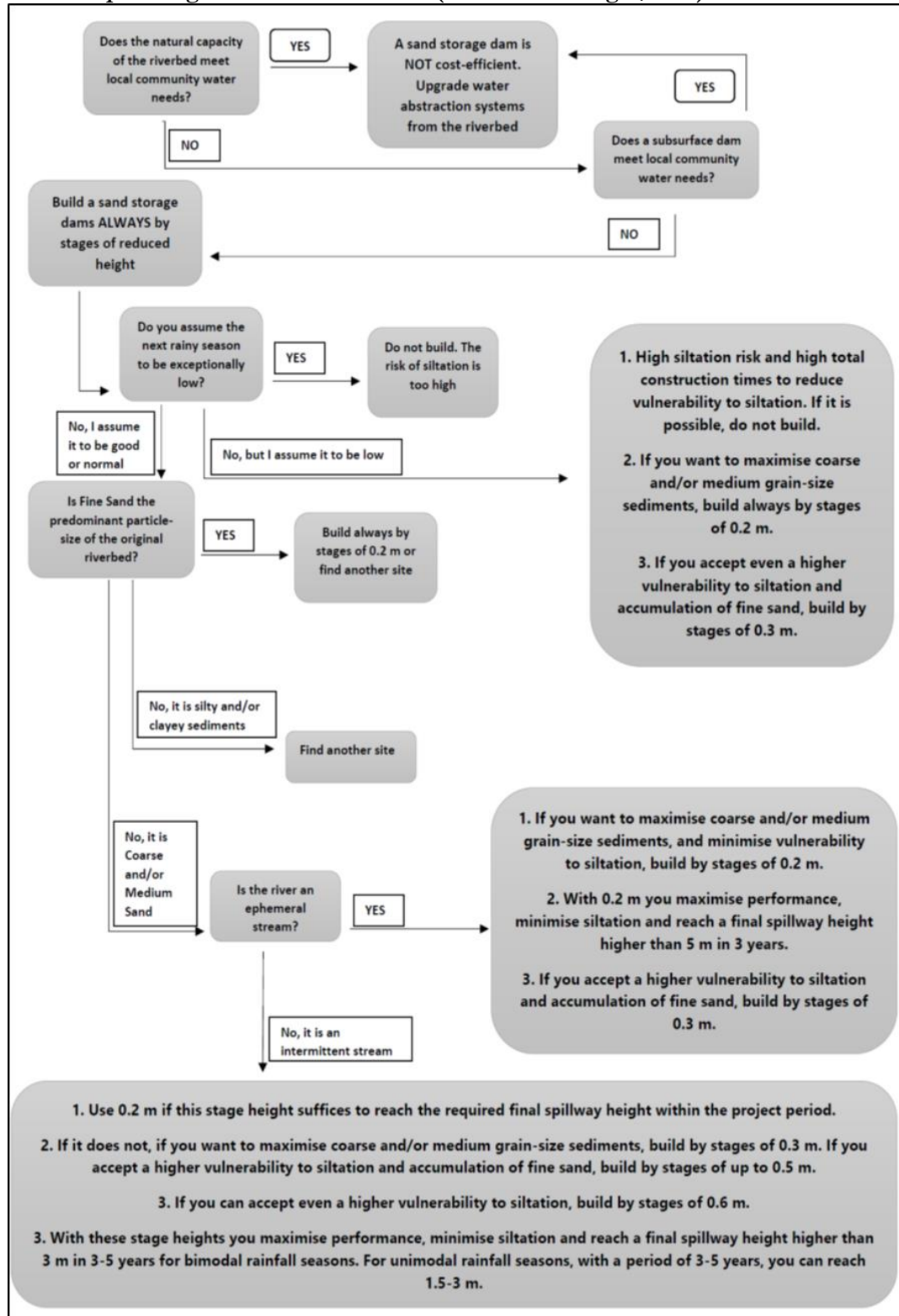

## RAINWATER HARVESTING & SAND DAMS

### Sand Dams

#### 4. Conclusions and Recommendations

Siltation dramatically reduces the performance, cost-efficiency and positive impacts of sand storage dams and it is affecting thousands of sand reservoirs in arid and semi-arid areas. In order to minimise siltation, a universal multi-stage spillway construction process is required. The stage height should be designed on a case-by-case basis by analysing historical bedload transport over a multi-year period. If this is not feasible, it is recommended to use a range of precautionary fixed stage heights on a case-by-case basis. The recommended stage heights are highly applicable to all arid and semi-arid regions due to the inherent variability of the bedload transport in these areas.

The large number of silted-up reservoirs coupled with a high specificity of suitable sites for sand storage dams makes relevant that attention is focused on restoring silted-up sand storage dams through hydraulic and/or mechanical desiltation technologies. Alternatively, silted-up sand storage dams provide an opportunity for holistic riverbed and riverbank reclamation activities, both for agriculture and landscape restoration, by means of smart-agroforestry systems, and integrated water and soil conservation activities.

#### 5. Acknowledgements

This research has not been funded by any organisation. We encourage donor organisations to contact us to scale up this research. The contribution of Jan Wibbing to section 3.4.3 has been funded by Olin gGmbH.

#### 6. References

- Alexandrov, Y., Laronne, J. B., & Reid, I. (2003). Suspended sediment transport in flash floods of the semi-arid northern Negev, Israel. *International Association of Hydrological Sciences, Publication*, (278), 346-352.
- Alexandrov, Y., Cohen, H., Laronne, J.B. and Reid, I. (2009). Suspended sediment load, bed load, and dissolved load yields from a semiarid drainage basin: A 15-year study. *Water Resources Research*, vol. 45, no. 8.
- Barzilai, R., Laronne, J. B., & Reid, I. (2013). Effect of changes in fine-grained matrix on bedload sediment transport in a gravel-bed river. *Earth Surface Processes and Landforms*, 38(5), 441-448.
- Billi, P. (2011). Flash flood sediment transport in a steep sand-bed ephemeral stream. *International Journal of Sediment Research*, 26(2), 193-209.
- Bot, A., Benites, J. (2005). The importance of soil organic matter: A key to drought-resistant soil and sustained food production. *FAO Soils Bulletin* 80, 2005.
- Brandt, S. A. (1999). Reservoir desiltation by means of hydraulic flushing: sedimentological and geomorphological effects in reservoirs and downstream reaches as illustrated by the Cachí Reservoir and the Reventazon River, Costa Rica (No. Thesis B821r). University of Copenhagen, Copenhagen (Denmark).
- Cantalice, J.R.B., Cunha Filho, M., Stosic, B.D., Piscocoy, V.C., Guerra, S.M. and Singh, V.P. (2013). Relationship between bedload and suspended sediment in the sand-bed Exu River, in the semi-arid region of Brazil. *Hydrological Sciences Journal*, 58(8), pp. 1789-1802.
- Daynes, C. N., Field, D.J., Saleeba, J.A., Cole, M.A., McGee, P.A. (2012). Development and stabilisation of soil structure via interactions between organic matter, arbuscular mycorrhizal fungi and plant roots. *Soil Biology and Biochemistry*, 57, pp. 683-694.
- De Trinchiera, J., Nissen-Petersen, E., Leal Filho, W., Otterpohl R. (2015). Factors affecting the performance and cost-efficiency of sand storage dams in south-eastern Kenya [conference paper]. E-proceedings of the 36th IAHR World Congress, The Hague, the Netherlands, 28 June – 3 July, 2015.
- De Trinchiera, J., Leal Filho, W., Otterpohl, R. (2016). Towards achieving universal levels of optimal performance by minimising siltation in sand storage dams. Manuscript under review submitted for publication.
- Fan, J., & Morris, G. L. (1992). Reservoir sedimentation. II: Reservoir desiltation and long-term storage capacity. *Journal of Hydraulic Engineering*, 118(3), 370-384.
- Gichuki, F.N. (2000). Makueni District Profile: Rainfall Variability, 1950–1997. Dryland Research Working Paper, no. 2. Somerset, England: Drylands Research.
- Gutteridge, R. C., Shelton, H. M. (1998). Forage tree legumes in tropical agriculture. Tropical Grassland Society of Australia Inc. Queensland, Australia.
- Lasage, R., Aerts, J., Mutiso, G., De Vries, A. (2008). Potential for community based adaptation to droughts: Sand dams in Kitui, Kenya. *Physics and Chemistry of the Earth, Parts A/B/C*, 33(1), 67-73.
- Lasage, R. and Verburg, P.H. (2015). Evaluation of small scale water harvesting techniques for semi-arid environments. *Journal of Arid Environments*, vol. 118, pp. 48-57.
- Liniger, H.P., Critchley, W. (2007). Where the land is greener. Case Studies and Analysis of Soil and Water Conservation Initiatives Worldwide. *World Overview of Conservation Approaches and Technologies*, 2007.
- Liniger, H.P., Mekdaschi Studer, R., Hauert, C., Gurtner, M. (2011). Sustainable Land Management in Practice – Guidelines and Best Practices for Sub-Saharan Africa. *TerrAfrica, World Overview of Conservation Approaches and Technologies (WOCAT) and Food and Agriculture Organization of the United Nations (FAO)*, 2011.



## RAINWATER HARVESTING & SAND DAMS

### Sand Dams

- Lucia, A., Recking, A., Martín-Duque, J. F., Storz-Peretz, Y., & Laronne, J. B. (2013). Continuous monitoring of bedload discharge in a small, steep sandy channel. *Journal of Hydrology*, 497, 37-50.
- Nichols, K. A. (2008). Indirect Contributions of AM Fungi and Soil Aggregation to Plant Growth and Protection. In *Mycorrhizae: Sustainable Agriculture and Forestry*, pp. 177-194. Springer, The Netherlands.
- Nilsson, A. (1988). Groundwater dams for small-scale water supply. London, U.K: Intermediate Technology Publications, 64 pp.
- Nissen-Petersen, E. (2000). Water from sand rivers. A manual on site survey, design, construction and maintenance of seven types of water structures in riverbeds. RELMA. Technical Handbook No. 23. Nairobi.
- Nissen-Petersen, E. (2006). Water from Dry Riverbeds. How dry and sandy riverbeds can be turned into water sources by hand-dug wells, subsurface dams, weirs and sand dams. ASAL Consultants Limited for the Danish International Development Assistance.
- Nissen-Petersen, E. (2011): Sand dams or silt traps?. In *Miti: The Tree Business Magazine for Africa*, n° 10, April-June. Nairobi, Kenya. Available at [http://betterglobefforestry.com/index.php/free-downloads/doc\\_download/82-sand-dams-or-silt-traps.html](http://betterglobefforestry.com/index.php/free-downloads/doc_download/82-sand-dams-or-silt-traps.html) [Accessed on 15th August 2016].
- Nissen-Petersen, E., De Trincheria, J. (2015) [conference presentation]. How to get more water from sand dams –For half the cost. International Rainwater Harvesting and Resilience Symposium, Addis Ababa, Ethiopia, 1st-12th June 2015. Available at [https://www.researchgate.net/publication/280303963\\_HOW\\_TO\\_GET\\_MORE\\_WATER\\_FROM\\_SAND\\_DAMS\\_-\\_FOR\\_HALF\\_THE\\_COST](https://www.researchgate.net/publication/280303963_HOW_TO_GET_MORE_WATER_FROM_SAND_DAMS_-_FOR_HALF_THE_COST) [Accessed on 15<sup>th</sup> August 2016].
- Ochieng, G. M., Otieno, F. A., Shitote, S. M., Sitters, C. C. (2008). Investigating the effect of step height increment, channel slope, and flow rate on specific yield of sand dams. Available at <http://www.evisa.co.za/literature/files/ID56%20Paper84%20Ochieng%20G.pdf> [Accessed on 15th August 2016].
- Pachauri, R. K. et al. (2014): Climate Change 2014: Synthesis Report. Contribution of Working Groups I, II and III to the Fifth Assessment Report of the Intergovernmental Panel on Climate Change / R. Pachauri and L. Meyer (editors) , Geneva, Switzerland, IPCC, 151 p., ISBN: 978-92-9169-143-2 ].
- Palm, C.A. (1995). Contribution of agroforestry trees to nutrient requirements of intercropped plants. *Agroforestry Systems* 30: 105-124. Kluwer Academic Publishers, 1995.
- Powell, D. M., Reid, I., Laronne, J. B., & Frostick, L. (1996). Bed load as a component of sediment yield from a semiarid watershed of the northern Negev. *IAHS Publications-Series of Proceedings and Reports-Intern Assoc. Hydrological Sciences*, 236, 389-398.
- Ramachandran Nair, P.K. (1993). *An Introduction to Agroforestry*. Kluwer Academic Publishers in cooperation with International Centre for Research in Agroforestry, 1993.
- Reid, I. and Frostick, L. E. (2011) Channel Form, Flows and Sediments of Endogenous Ephemeral Rivers in Deserts, in *Arid Zone Geomorphology: Process, Form and Change in Drylands*, Third Edition (ed. D. S. G. Thomas), John Wiley & Sons, Ltd, Chichester, UK.
- Ruiz, S., Or, D., Schymanski, S.J. (2015). Soil Penetration by Earthworms and Plant Roots— Mechanical Energetics of Bioturbation of Compacted Soils. *PLoS ONE* 10(6): e0128914. Doi: 10.1371/ journal.pone.0128914, 2015.
- Stephens, T. (2010). Manual on small earth dams: a guide to siting, design and construction. No. 64. Food and Agriculture Organization of the United Nations (FAO). Rome, Italy.
- Studer, M. and Liniger, H. (2013). *Water Harvesting: Guidelines to Good Practice*. Centre for Development and Environment (CDE), Bern; Rainwater Harvesting Implementation Network (RAIN), Amsterdam; MetaMeta, Wageningen; The International Fund for Agricultural Development (IFAD), Rome.
- Truong, P. (2000). Vetiver grass system: Potential applications for soil and water conservation in northern California [conference paper]. Stiff Grass Technology Seminar, Brisbane, Australia.
- Vidulich, J. (2015). Spillway staging and selective sediment deposition in sand storage dams. MSc Thesis, Oregon State University, Oregon, U.S.
- Wipplinger, O. (1958). Storage of water in sand. South West Africa Administration Water Affairs Branch. Windhoek, Namibia.
- Young, A. (1989). *Agroforestry for Soil Conservation*. CAB International. International Council for Research in Agroforestry, 1989.

## RAINWATER HARVESTING & SAND DAMS

### Sand Dams

# The potential for sand dams to increase the adaptive capacity of East African drylands to climate change

Type: Long Paper (up to 6,000 words)

**Authors** Catherine Ryan, Birkebeck College, University of London, United Kingdom, [cate\\_is@yahoo.com](mailto:cate_is@yahoo.com), ++44 7981 818 329

### Abstract/Summary

Drylands are home to more than two billion people and are characterised by frequent, severe droughts which are expected to be exacerbated by climate change. A potentially simple and cost-effective mitigation measure against drought are sand dams. This little-known technology promotes subsoil rainwater storage to support dryland agroecosystems. This study analyses multi-year satellite imagery to compare vegetation at sand dam sites and control sites over selected drought periods, using the normalised difference vegetation index. The results show that vegetation biomass was consistently and significantly higher at sand dam sites during periods of extended droughts. It is also shown that vegetation at sand dam sites recovers more quickly from drought. The observed findings corroborate other modelling-based and socio-economic research. Using past periods of drought as an analogue to climate change conditions, this study indicates that sand dams have the potential to increase adaptive capacity and resilience to climate change in drylands.

### Introduction

Drylands cover more than 41 % of the world’s surface (Safriel and Adeel 2005), and they are home to 2.3 billion people, or nearly 30 % of the world’s population (UNDP 2014). Over one billion people from the developing world rely on dryland natural resources for their livelihoods (UNDP 2014).

Drylands are characterised by frequent, severe drought and climate extremes. Climate change is expected to increase the frequency and exacerbate the impacts of these, resulting in increased water scarcity. For most dryland regions, climate models predict higher temperatures, decreased precipitation, and an increase in intensity and frequency of extreme events such as droughts and heavy rainfall (Sorenson et al. 2008). Observational data suggests East African drylands are getting warmer with less rainfall, resulting in a drying effect that will increase with further climate change (Funk 2010). This threatens the ecosystems and people who depend on them, particularly agroecosystems where humans are heavily reliant on ecosystem resources for their livelihoods (Boko et al. 2007; Fischlin et al. 2007; Speranza 2012; Kilroy 2015). There is therefore an urgent need for appropriate and sustainable technologies that improve the ability of dryland communities and ecosystems to be resilient in the face of such challenges (Tucker et al. 2015).

In recent years the international community has turned its attention to adaptation responses to climate change (Boko et al. 2007; Schipper and Burton 2009). Sand dams are an example of such a potential response but are currently only promoted by a small number of national and international non-governmental organisations (NGO’s). Sand dams are rain water harvesting structures which are already being used as a response to conditions of water scarcity in drylands. They are common to south-east Kenya only, and little systematic research has been done on them. However, the small number of studies that have been carried out suggest positive, sustainable, environmental and social impacts that could increase adaptive capacity to climate change conditions (Lasage et al. 2008; Pauw et al. 2008; Quilis et al. 2009).

It is timely to consider the usefulness of the wider application of sand dams as an appropriate technology for drylands in this policy environment. The first sand dam projects were implemented [50 years ago, with

## RAINWATER HARVESTING & SAND DAMS

### Sand Dams

the majority built in the last 15 years, so there is now the opportunity to empirically test the effectiveness of sand dams during drought periods using remote sensing approaches. This paper describes such a research project. We will do this by first introducing the basic principles of the sand dam concept and contextualise its potential to improve climate change-related drought resilience. The methods section will then introduce data sources, the locations of case study dams and analytical approaches. This is then followed by a presentation of the results and a discussion of their significance for climate change adaptation and mitigation.

### Principles of the sand dam concept

A sand dam is a reinforced concrete wall built across a seasonal riverbed to harvest rainwater (Fig. 1). Its objective is to support multiple uses, including water for human consumption, small-scale irrigation and livestock watering (Foster and Tuinhof 2004; Hut et al. 2008).

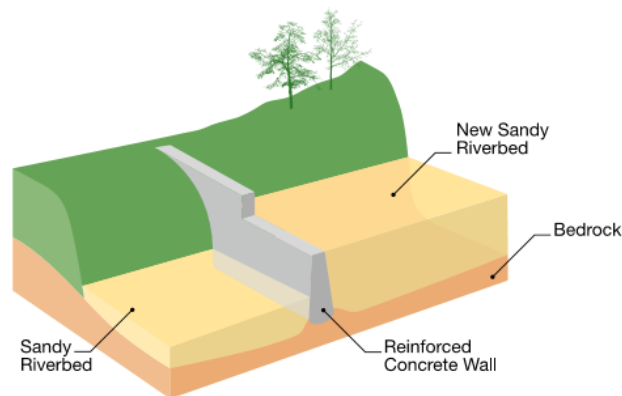
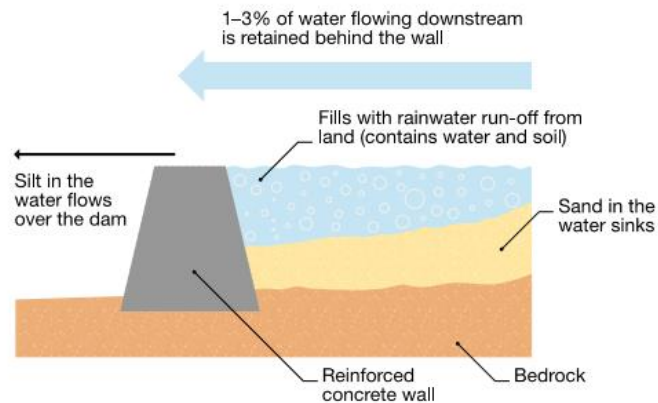

**Fig. 1** Placement of a sand dam in a river bed. *Source* Excellent Development (2011)

After construction, the first seasonal rains fill the dam area with water, silt and sand in both upstream and downstream directions. The coarser sand has the highest settling velocity and deposits upstream of the dam. The newly deposited sand provides additional water storage capacity. Suspended material with smaller grain sizes, such as silt, will wash over the top of the dam and continue downstream (Fig. 2).

## RAINWATER HARVESTING & SAND DAMS

### Sand Dams



**Fig. 2** Conceptual illustration of how a sand dam works. *Source* Excellent Development (2011)

Sand dams are carefully designed so that the natural flow of the river is not altered, so as to avoid erosion downstream of the dam. For example, dams are placed on long straight stretches of river rather than before a bend. A secondary spillway centres the water within the river bed and wing walls are built to keep the flood waters from going around the sand dam, causing erosion and eventually undercutting the dam walls. Good land management practices accompany any sand dam build. Terracing and plantings occur in the catchment area to prevent run off, erosion and siltation. This is important because silt reduces the dams' ability to store water. Small rills or gullies are blocked to prevent soil erosion with plantings, sand bags or smaller sand dams (Maddrell and Neal 2012).

With each rainfall event, the size of the sand reservoir increases allowing more water to be stored. When mature, the dam comprises between 25 and 40 % water (Maddrell and Neal 2012). The dam also obstructs groundwater naturally flowing through the permeable riverbed. This creates higher upstream groundwater levels that subsequently infiltrate into the adjacent riverbanks, thus also raising groundwater levels in those riverbanks (Hoogmoed 2007). The subsurface groundwater flows and seasonal rains recharge the groundwater aquifer (Hoogmoed 2007).

Water can then be extracted by the local population by using wells, pumps or scoop holes in the riverbed or banks upstream of the dam (Quilis et al. 2009). The saturated sand material will also shield water from evaporation and contamination from animals. Additionally, sand acts as a natural slow filter, purifying the water and making it safer for humans to drink (Avis 2014).

### The potential for sand dams to increase adaptive capacity to climate change

Adaptive capacity can be understood as the capability of a system to respond to climate variability by reducing vulnerability or enhancing resilience (Adger et al. 2007). These two elements, vulnerability and resilience are further defined: vulnerability as the ability or inability of individuals and systems to respond to external stress placed on livelihoods (Kelly and Adger 2000); resilience as the capacity to absorb such disturbances so as to retain function, structure, identity and feedbacks (Walker et al. 2004).

In general, agro-ecosystems in the drylands of Africa have low adaptive capacity and high inherent exposure to climate change. Subsequently, subsistence farmers and ecosystems currently have low resilience to climate shocks such as droughts (Boko et al. 2007). Their high vulnerability is due to the reliance on rainfall for economic and social development. Makueni District in south-east Kenya is an example of such an agro-ecosystem. Makueni has experienced frequent and severe droughts in recent decades; such conditions are analogous to those projected under climate change (Christensen et al. 2007; Fischlin et al. 2007). Makueni has also experienced increasing population and population density since 1950, when it was barely inhabited. Before 1950, the dominant arid and semiarid areas served as extensive

## RAINWATER HARVESTING & SAND DAMS

### Sand Dams

grazing grounds, but these areas are now permanent croplands (Speranza 2010) with an average population density in 2009 of 110 people per square km (Kenya National Bureau of Statistics 2013). The main issues facing the county are population growth (1.4 % per year), high levels of poverty (64.3 %), inadequate water supplies and population pressure on arable land affecting agricultural productivity (Republic of Kenya 2013). It is clear that anthropogenic pressures in the region have increased substantially in past decades, providing an added need for more sustainable water management that increases resilience to drought.

There is substantial concern that the adaptive capacity of the dryland pastoralists, smallholder and subsistence farmers may be overstretched by climate change, leading to increased poverty and unsustainable coping strategies (Soerensen et al. 2008). This is reflected by a renewed interest in ambitious schemes such as the Great Green Wall where large-scale tree planting means aims to reduce desertification in the Sahel region (O'Connor and Ford 2014). Smaller-scale technologies such as sand dams are an alternative way to increase resilience and decrease vulnerability of natural and human systems, and to increase their adaptive capacity (Boko et al. 2007; Adger et al. 2007). In south-east Kenya sand dams have proved to be relatively cheap and easy to build. Most of the cost is in construction, and thereafter they require low or no maintenance over their lifetime of 50 years or more. In Kenya the community provides much of the labour voluntarily, but siting expertise and coordination is provided by a handful of local NGO's. Steel and cement are bought in (Ertsen and Hut 2009). The average cost per m<sup>3</sup> of water stored is around US\$1.15. (Akvopedia 2016). This makes them a cost-effective and accessible adaptation technology for the most vulnerable in society.

Vegetation plays an important role in drylands through valuable provisioning, regulating, supporting and cultural services to humans. Resilience to drought in drylands is key to the continuation of these services under climate change conditions. Hydro-geological models suggest sand dams are a way to increase groundwater due to a c. 40 % increase of storage in riverbanks (Borst and de Haas 2006; Jansen 2007; Hoogmoed 2007). Moreover, modelling suggests the sand reservoir fills within days of the first rains, remaining through the season and river banks then fill within a month of the first rains. Groundwater is maintained throughout dry seasons and drought (Borst and de Haas 2006; Hut et al. 2008; Quilis et al. 2009) increasing the length of time communities have water reserves by up to 2.5 months (Pauw et al. 2008). These features enhance the resilience of vegetation to drought at sand dam sites.

### Context, aims and activities undertaken

Previous studies have not empirically demonstrated this enhanced resilience, but land cover change detection studies on the impact of sand dams go some way to validate modelling assumptions. Manzi and Kuria (2011) found that sand dams have a positive relation to land cover type; the presence of sand dams can create a shift in land cover from bare soils, before sand dams were built, to vegetated cover types afterwards. However, the study did not use control sites and the observed increase in vegetation may instead reflect the reported general greening in the region over the period studied (Conway et al. 2008).

The aim of this research is therefore to empirically test the hypothesis that sand dams increase the adaptive capacity of drylands by increasing the resilience of vegetation through times of water scarcity. This research tests the findings and assumptions from hydro-geological modelling studies (Borst and de Haas 2006; Hut et al. 2008; Quilis et al. 2009). A key indicator for this will be vegetation health, as it can be expected to improve at sand dam sites due to the additional water stored in sand dam reservoirs and riverbanks. Vegetation growth is frequently limited by lack of water, thus the relative density of vegetation is a good indicator of drought (Weier and Herring 2000).

Normalised difference vegetation index (NDVI) is the most commonly used index for vegetation density. Changes in vegetation can therefore be measured by differences in the NDVI calculated from satellite images. Furthermore, indications of the impact of sand dams on vulnerability can be identified from changes in NDVI. Specific objectives for this study include:

## RAINWATER HARVESTING & SAND DAMS

### Sand Dams

1. to measure and compare vegetation at sand dam and control sites over selected periods of drought using NDVI;
2. to draw inferences from results on the impact of sand dams on vegetation in periods of water scarcity;
- and 3. to draw inference from results on the potential of sand dams as an adaptation response to climate change in drylands.

### Main results and lessons learnt

Throughout the 7-year observation period, NDVI was consistently higher at sand dam sites.

**Fig. 4** Comparison of mean NDVI between 2005 and 2012. Periods of extreme drought are indicated by red shading, periods of drought by yellow shading and periods of relative greening by green shading

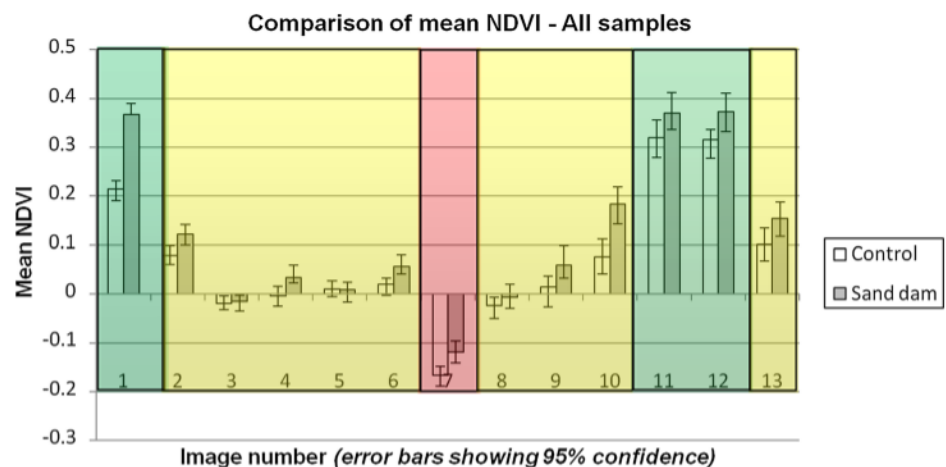

The results of this research project demonstrate that sand dams substantially increased the ability of drylands to buffer extended periods of water scarcity. NDVI is a proxy for plant health, productivity, and biomass. A relative increase in NDVI at sand dam sites compared to non-sand dam indicates an improved resilience to adverse conditions. Mean NDVI at all sand dam sites was consistently significantly higher than at control sites during periods of water scarcity. Even during ‘Drought’ and ‘Extreme Drought’ conditions, NDVI values at sand dam sites were consistently higher than controls.

It was also demonstrated that vegetation at sand dam sites recovered more quickly from drought. After showers occurred within a drought period, a ‘Relative Greening’ effect was more substantial at sand dam sites.

### Conclusions and Recommendations

This study provides the first robust empirical quantification that sand dams have a substantial potential to mitigate drought events and addresses the need for more rigorous evidence base that can inform decision-making in climate change adaptation (De Souza et al. 2015). Sand dam sites show consistently, statistically significantly higher mean NDVI throughout the 7-year observation period.

We also observed a buffering effect of sand dams due to a slower drying out of vegetation at sand dam sites at the onset of droughts, and faster, more sustained recovery after precipitation. These findings support the hypothesis that sand dams are an effective approach to increase the adaptive capacity of drylands by increasing the resilience of vegetation through times of water scarcity. Increased resilience increases the adaptive capacity of drylands to climate change. The satellite-based observations of this study agree well with the literature on modelled groundwater flows and storage around sand dams, as well as impacts on land cover and socio-economic indicators. It can therefore be concluded that the relatively simple sand dam technology is highly appropriate as an adaptation response to climate change in

## RAINWATER HARVESTING & SAND DAMS

### Sand Dams

drylands. Due to their simple design and construction, sand dams are therefore a useful and cost-effective development approach. They also provide an interesting tool for mitigating the future effects of climate change.

### Acknowledgements

Acknowledgments go to the communities that built the sand dams in the study and for sharing information about them, including Makuta Mwea and Nzyaa Muiyso Self Help Groups. Sincere appreciation goes to the NGO's that gave their time and expertise in the preparation of this research including the Africa Sand Dam Foundation, Utooni Development Group and Excellent Development UK. Many thanks to Emma Newcombe and Steve GoreSmith for support.

### References

- Adeel Z, Safriel U, Niemeijer D, White R (2005) Ecosystems and Human Well-Being. Desertification Synthesis, Millennium Ecosystem Assessment. <http://www.millenniumassessment.org/documents/document.355.aspx.pdf>. Accessed 16 September, 2012
- Adger WN, Agrawala S, Mirza MMQ, Conde C, O'Brien K, Pulhin J, Pulwarty R, Smit B, Takahashi K (2007) Assessment of adaptation practices, options, constraints and capacity. In: Parry ML, Canziani OF, Palutikof JP, van der Linden PJ, Hanson CE (eds) (2007) *Climate Change 2007: Impacts, Adaptation and Vulnerability. Contribution of Working Group II to the Fourth Assessment Report of the Intergovernmental Panel on Climate Change*. Cambridge University Press, Cambridge
- Aerts J, Lasage R, Beets W, de Moel H, Mutiso G, Mutiso S, de Vries A (2007) Robustness of Sand Storage Dams under Climate Change. *Vadose Zone Journal* 6, 3: 572–580. doi: 10.2136/vzj2006.0097
- Akwopedia, (2016) Sand dam. <http://goo.gl/wChz61>. Accessed 31 January, 2016
- Anyamba A, Tucker CJ (2005) Analysis of Sahelian vegetation dynamics using NOAA-AVHRR NDV data from 1981-2003. *J Arid Environ* 63:596-614. doi: 10.1016/j.jaridenv.2005.03.007
- Avis O (2014) A Microbial Analysis of Water in Sand Dams and Associated Abstraction Methods. Masters thesis, London School of Hygiene and Tropical Medicine
- Boko M, Niang I, Nyong A, Vogel C, Githeko A, Medany M, Osman-Elasha B, Tabo R, Yanda P (2007) Africa. In: Parry, M.L., Canziani, O.F., Palutikof, J.P., van der Linden, P.J., Hanson C.E. (eds) (2007) *Climate Change 2007: Impacts, Adaptation and Vulnerability. Contribution of Working Group II to the Fourth Assessment Report of the Intergovernmental Panel on Climate Change*. Cambridge University Press, Cambridge, pp. 433-467
- Borst L, de Haas SA (2006) Hydrology of Sand Storage Dams. A case study in the Kiindu catchment, Kitui district, Kenya. M.Sc. thesis, Vrije Universiteit, Amsterdam
- Brown ME, Pinzon JE, Prince SD (2006) The Effect of Vegetation Productivity on Millet Prices in the Informal Markets of Mali, Burkina Faso and Niger. *Climatic Change* 78, 1: 181-202. doi:10.1007/s10584-006-9096-4
- Carlson TN, Ripley DA (1997) On the relation between NDVI, fractional vegetation cover and leaf area index. *Remote Sens Environ* 62: 241-252. doi:10.1016/S0034-4257(97)00104-1
- Christensen JH, Hewitson B, Busuioc A, Chen A, Gao X, Held I, Jones R, Kolli RK, Kwon WT, Laprise R, Magaña Rueda V, Mearns L, Menéndez CG, Räisänen J, Rinke A, Sarr A, Whetton P (2007) Regional Climate Projections. In: Solomon S, Qin D, Manning Z, Chen Z, Marquis M, Avery KB, Tignor M, Miller HL (eds) (2007) *Climate Change 2007: The Physical Science Basis. Contribution of Working Group I to the Fourth Assessment Report of the Intergovernmental Panel on Climate Change*. Cambridge University Press, Cambridge
- Claessens L, Antle JM, Stoorvogel JJ, Valdivia RO, Thornton PK, Herrero M (2012) A method for evaluating climate change adaptation strategies for small-scale farmers using survey, experimental and modeled data. *Agr Syst* 111:85-95. doi:10.1016/j.agsy.2012.05.003
- Conway D, Persechino A, Ardoin-Bardin S, Hamandawana H, Dickson M, Dieulin C, Mahe G (2008) Rainfall and water resources variability in sub-Saharan Africa during the 20th century, Norwich: Tyndall Centre Working Paper. <http://www.tyndall.ac.uk/sites/default/files/wp119.pdf>. Accessed 01 September, 2012
- De Fries R, Hansen M, Townshend J (1995). Global Discrimination of Land Cover Types from Metrics Derived from AVHRR Pathfinder Data. *Remote Sens Environ* 54: 209-222. doi:10.1016/0034-4257(95)00142-5
- De Fries RS, Hansen M, Townshend JRG, Sohlberg R (1998). Global land cover classifications at 8 km spatial resolution: the use of training data derived from Landsat imagery in decision tree classifiers, *Int. J Remote Sens* 19,16: 3141-3168. doi:10.1080/014311698214235
- De Souza K, Kituyi E, Harvey B, Leone M, Murali KS, Ford JD (2015). Vulnerability to climate change in three hot spots in Africa and Asia: key issues for policy-relevant adaptation and resilience-building research. *Regional Environmental Change*, 15,5: 747-753. doi:10.1007/s10113-015-0755-8
- Ertsen M, Hut R (2009) Two waterfalls do not hear each other. Sand-storage dams, science and sustainable development in Kenya. *Phys Chem Earth* 34: 14-22. doi:10.1016/j.pce.2008.03.009
- Excellent Development (2011) Pioneers of Sand Dams. <http://www.excellentdevelopment.com/site-assets/files/resources/publications/pioneers-of-sand-dams.pdf>. Accessed 07 October, 2012

## RAINWATER HARVESTING & SAND DAMS

### Sand Dams

- FEWSNET (2011) East Africa: Past year one of the driest on record in the eastern Horn. USAID  
[http://www.fews.net/docs/Publications/FEWS%20NET%20EA\\_Historical%20drought%20context\\_061411.pdf](http://www.fews.net/docs/Publications/FEWS%20NET%20EA_Historical%20drought%20context_061411.pdf). Accessed 07 May, 2012
- FEWSNET (2012) East Africa, Kenya. Archive: Drought and Flood Hazards Assessment. USAID.  
<http://www.fews.net/pages/countryarchive.aspx?pid=300&gb=ke&l=en>. Accessed 01 May, 2012
- FEWSNET (2012) Famine Early Warning System Network. USAID. <http://www.fews.net/pages/country.aspx?gb=ke&l=en>. Accessed 15 April, 2012
- Field A (2005) *Discovering statistics with SPSS, 2nd Edition*. Sage Publications, London
- Fischlin A, Midgley GF, Price JT, Leemans R, Gopal B, Turley C, Rounsevell MDA, Dube OP, Tarazona J, Velichko AA (2007) Ecosystems, their properties, goods, and services. In: Parry ML, Canziani OF, Palutikof JP, van der Linden PJ, Hanson CE (eds) (2007) *Climate Change 2007: Impacts, Adaptation and Vulnerability. Contribution of Working Group II to the Fourth Assessment Report of the Intergovernmental Panel on Climate Change*, Cambridge University Press, Cambridge, p.211-272
- Food and Agriculture Organisation (FAO) (2005) *New\_LocClim. Local Climate Estimator*.  
[http://www.fao.org/nr/climpag/pub/en0201\\_en.asp](http://www.fao.org/nr/climpag/pub/en0201_en.asp). Accessed July - September, 2012
- Food and Agriculture Organisation (FAO) (2007) *FAO Climpag. FAOClim-Net*.  
[http://geonetwork3.fao.org/climpag/agroclimdb\\_en.php](http://geonetwork3.fao.org/climpag/agroclimdb_en.php). Accessed July - September, 2012
- Foster S, Tuinhof A (2004) *Sustainable Groundwater Management. Lessons from Practice. Case Profile Collection Number 5. Brazil, Kenya*. [http://siteresources.worldbank.org/INTWRD/Resources/GWMATE\\_English\\_CP\\_05.pdf](http://siteresources.worldbank.org/INTWRD/Resources/GWMATE_English_CP_05.pdf). Accessed 15 September, 2012
- Funk C (2010) *A Climate Trend Analysis of Kenya, Famine Early Warning Systems Network - Informing Climate Change Adaptation Series*. <http://pubs.usgs.gov/fs/2010/3074/>. Accessed, 10 July, 2012
- Holling CS (1973) Resilience and Stability of Ecological Systems. *Ann Rev Ecol Syst* 4:1-23. doi: 10.1146/annurev.es.04.110173.000245
- Hoogmoed M (2007) *Analyses of impacts of a sand storage dam on groundwater flow and storage. Groundwater flow modelling in Kitui District Kenya*. MSc. thesis, Vrije Universiteit, Amsterdam
- Hut R, Ertsen M, Joeman N, Vergeer N, Winsemius H, van de Giesen N (2008) Effects of sand storage dams on groundwater levels with examples from Kenya. *Phys Chem Earth* 33, 1: 56-66. doi:10.1016/j.pce.2007.04.006
- International Livestock Research Institute (2010) *An assessment of the response to the 2008 -2009 drought in Kenya. A report to the European Union Delegation to the Republic of Kenya, Nairobi*.  
[http://ceas.europa.eu/delegations/kenya/documents/more\\_info/assessment\\_of\\_the\\_response\\_2008\\_en.pdf](http://ceas.europa.eu/delegations/kenya/documents/more_info/assessment_of_the_response_2008_en.pdf). Accessed 27 August, 2012
- Jaetzold R, Schmidt H, Hornetz B, Shisanya C (2006) *Farm Management Handbook of Kenya, Vol II, East Kenya, Eastern Province, 2nd Edition*. Ministry of agriculture, Nairobi, Kenya
- Jansen J (2007) *The influence of sand dams on rainfall-runoff response and water availability in the semi-arid Kiindu catchment, Kitui District, Kenya*. M.Sc. thesis, Vrije Universiteit, Amsterdam
- Johnson N, Wambile A (eds) (2011) *The Impacts of the Arid Lands Resource Management Project (ALRMP II) on Livelihoods and Vulnerability in the Arid and Semi-Arid Lands of Kenya*. ILRI Research Report 25, Nairobi, Kenya.  
<http://www.ilri.org/ilrinews/index.php/archives/tag/alrmpii>. Accessed 21 April, 2012
- Kelly PM, Adger WN (2000) Theory and practice in assessing vulnerability to climate change and facilitating adaptation. *Climatic Change* 47, 4: 325 -352. In: Schipper, E.L.F and Burton, I.(eds), (2009) *The Earthscan Reader on Adaptation to Climate Change*. Earthscan, London
- Kenya Food Security Steering Group (2011) *The 2011 long rains season assessment report*. Government of Kenya.  
<http://home.wfp.org/stellent/groups/public/documents/ena/wfp240180.pdf>. Accessed 16 August, 2015
- Kenya National Bureau of Statistics (2013) *Statistical Abstract 2013*.  
[http://www.knbs.or.ke/index.php?option=com\\_phocadownload&view=category&id=106&Itemid=1177](http://www.knbs.or.ke/index.php?option=com_phocadownload&view=category&id=106&Itemid=1177). Accessed 03 January 2016
- Kilroy G (2015) A review of the biophysical impacts of climate change in three hotspot regions in Africa and Asia. *Regional Environmental Change*, 15,5: 771-782. doi:10.1007/s10113-014-0709-6
- Lasage R, Aerts J, Mutiso GCM, De Vries A (2008) Potential for community based adaptation to droughts: Sand Dams in Kitui, Kenya. *Phys Chem Earth Vol. 33, 1-2: 67-73*. doi:10.1016/j.pce.2007.04.009
- Maddrell S, Neal I (2012) *Sand dams: a Practical Guide*. Excellent Development, London.  
<http://www.excellentdevelopment.com/resources/publications>. Accessed 15 September, 2012
- Manzi H, Kuria D (2011) The use of satellite images to monitor the effect of sand dams on stream bank land cover changes in Kitui District. *Journal of Agriculture, Science, and Technology*, Vol 13 No2:133 -150.  
<http://www.ajol.info/index.php/jagst/article/view/113207>
- Markham BL, Helder DL (2012) Forty-year calibrated record of earth-reflected radiance from Landsat: A review. *Remote Sens Environ* 122: 30-40. doi:10.1016/j.rse.2011.06.026
- Mutuku NB (2012) *Impact of Sand Dams on Social Economic Status of the Local Inhabitants. A case of Kitui Central Division, Kenya*. LAP LAMBERT Academic Publishing, Germany
- O'Connor D, Ford J (2014) Increasing the Effectiveness of the “Great Green Wall” as an Adaptation to the Effects of Climate Change and Desertification in the Sahel. *Sustainability* 6, 10:7142-7154. doi:10.3390/su6107142
- Orient Quilis R (2007) *Modelling sand storage dams systems in seasonal rivers in arid regions. Application to Kitui district (Kenya)*. Masters thesis, Delft University Technology, UNESCO-IHE. Delft, Netherlands
- Pauw WP, Mutiso S, Mutiso G, Manzi HK, Lasage R, Aerts JCJH (2008) *An Assessment of the Social and Economic Effects of the Kitui Sand Dams Community based Adaptation to Climate Change*, SASOL Foundation and IVM Institute for



## RAINWATER HARVESTING & SAND DAMS

### Sand Dams

- Environmental studies Vrije University, Amsterdam. <http://dare.uvu.vu.nl/bitstream/1871/20935/2/R-08-08.pdf>. Accessed 21 August, 2012
- Quilis RO, Hoogmoed M, Ertsen M, Foppen JW, Hut R, de Vries A (2009) Measuring and modeling hydrological processes of sand-storage dams on different spatial scales. *Phys and Chem Earth* 34: 289–298. doi:10.1016/j.pce.2008.06.057
- Republic of Kenya (2013) Makueni County First County Integrated Development Plan 2013-2017. <http://www.makueni.go.ke/sites/default/files/documents/MAKUENI%20CIDP%205TH%20APRIL%202014.compressed.pdf>. Accessed 03 January, 2016
- Running SW, Nemani RR, Heinsch FA, Zhao M, Reeves M, Hashimotoa H (2004) Continuous Satellite-Derived Measure of Global Terrestrial Primary Production. *BioScience*, 54,6: 547-560. doi:10.1641/0006-3568(2004)054[0547:acsmog]2.0.co;2
- Safriel U, Adeel Z (2005) Dryland systems, Chapter 22, p. 623-662 In: Hassan R, Scholes R, Ash N (eds) (2005) *Ecosystems and human well-being: current state and trends. The Millennium Ecosystem Assessment, Vol. 1.* Washington, D.C: Island Press. <http://www.maweb.org/documents/document.291.aspx.pdf>. Accessed 04 August, 2012
- Sahin V, Hall MJ (1996) The effects of afforestation and deforestation on water yields. *J Hydrol* 178: 293-309. doi:10.1016/0022-1694(95)02825-0
- Schipper ELF, Burton I (2009) *The Earthscan Reader on Adaptation to Climate Change.* Earthscan, London
- Sørensen L, Trx A, Duchrow A (2008) Sustainable land management in drylands – challenges for adaptation to climate change. In: Kamotho S, Strahm W, Wolfangel C (eds) (2008) *The nature of drylands, diverse ecosystems, diverse solutions.* IUCN World Conservation Congress Barcelona 2008. <http://data.iucn.org/dbtw-wpd/edocs/2008-023.pdf>. Accessed 10 July, 2012
- Speranza CI (2010) Drought Coping and Adaptation Strategies: Understanding Adaptations to Climate Change in Agro-pastoral Livestock Production in Makueni, District, Kenya. *European Journal of Development Research*, 22, 5:623-642. doi:10.1057/ejdr.2010.39
- Speranza CI (2012) Buffer capacity: capturing a dimension of resilience to climate change in African smallholder agriculture. *Regional Environmental Change* 13, 3: 521-535. doi:10.1007/s10113-012-0391-5
- Tucker CJ, Townshend JRG, Goff TE (1985) African Land-Cover Classification Using Satellite Data. *Science, New Series*, 227,4685: 369-375. Doi:10.1126/science.227.4685.369
- Tucker J, Daoud M, Oates N, Few R, Conway D, Mtisi S, Matheson S (2015) Social vulnerability in three high-poverty climate change hot spots: What does the climate change literature tell us? *Regional Environmental Change*, 15,5: 783-800. doi:10.1007/s10113-014-0741-6
- UNDP (2014) *Environment and Energy, Drylands Development Centre, Where We Work.* <http://web.undp.org/drylands/where.html>. Accessed 19 January, 2014
- Unganai LS, Kogan FN (1998) Drought monitoring and corn yield estimation in Southern Africa from AVHRR data. *Remote Sens Environ* 63, 3: 219 -232. doi:10.1016/S0034-4257(97)00132-6
- United States Geological Survey (2012a) *Earth Explorer.* <http://earthexplorer.usgs.gov/>. Accessed February - September, 2012
- United States Geological Survey (2012b) *USGS Global Visualisation Viewer.* <http://glovis.usgs.gov/>. Accessed February-September, 2012
- Walker B, Holling CS, Carpenter SR, Kinzig A (2004) Resilience, adaptability and transformability in social–ecological systems. *Ecol Soc* 9, 2:5
- World Resources Institute (2012) *Drylands, People, and Ecosystem Goods and Services: A Web-Based Geospatial Analysis* <http://www.wri.org/publication/drylands-people-and-ecosystem-goods-and-services>. Accessed 10 July, 2012

## WATER QUALITY, SAFETY AND TREATMENT

### Water Quality & Water Safety

## 3.7 WATER QUALITY, SAFETY AND TREATMENT

### 3.7.1 Water Quality & Water Safety

---

## A Microbial Analysis of Water in Sand Dams and Associated Abstraction Methods

---

Type: Long Paper (up to 6,000 words)

**Authors:** *Orlando Avis, Excellent Development*

#### Abstract/Summary

Drylands support the lives over 2 billion people, 90% of whom live in developing countries. Sand dams are a cost effective rain water harvesting solution for use in rural drylands with capacity to bring water security to some of the most marginalised communities in the world. Limited understanding of sand dam water quality has been a major barrier to mass adoption. This novel research, carried out with support from London School of Hygiene and Tropical Medicine, is the first scientific study of sand dam water quality. 83% of dams sampled were free from contamination; the remainder presented very low risk to human health based on the WHO sample risk classification scheme. Of the two abstraction methods tested shallow wells fitted with Afridev pumps were significantly safer than scoop holes. Further research, underway in Kenya and Zimbabwe support these findings.

#### Introduction

##### Water As a Right

*“the human right to water is indispensable for leading a life in human dignity. It is a prerequisite for the realization of other human rights”.*

General comments 15 (UN, 2002 )

In 2002 the UN committee on economic, social and cultural rights recognised access to sufficient, safe, acceptable, affordable, and physically accessible water as a human right (UN 2014a). This was reflected in the millennium development goals (MDGs) target 7C, to “halve the number of people without access to safe drinking water by 2015 (UN 2014b)”. Despite global success this target was not realized regionally in Sub-Saharan Africa. Major Barriers included, access in rural areas, increasing desertification and population growth (UN, 2012) The current UN objective, outlined in sustainable development goal 6.1, aims to “By 2030, achieve universal and equitable access to safe and affordable drinking water for all”. This will be a major challenge. Only 68% of people on the continent have access to improved water sources (UN, 2015).

Makueni County, Kenya, is a semi-arid region with very low and erratic annual precipitation and frequent droughts (PAI 2011). Water shortages in the region are the result of physical and economic scarcity (ibid.). As such, a low cost solution with the capacity to store water safe for human consumption is in high demand. One potential solution is the sand dam.

##### Sand Dams

A sand dam is an impermeable wall built during the dry season across an ephemeral riverbed (excellent development 2013). During the wet season, sand collects upriver of the wall. Water is stored within this sand and can be abstracted during the following dry season (Lasage et al., 2008). Though there are a

## WATER QUALITY, SAFETY AND TREATMENT

### Water Quality & Water Safety

number of abstraction methods, the two most frequently employed in this study area are scoop holes and wide bore shallow wells. These will be the focus of this research paper.

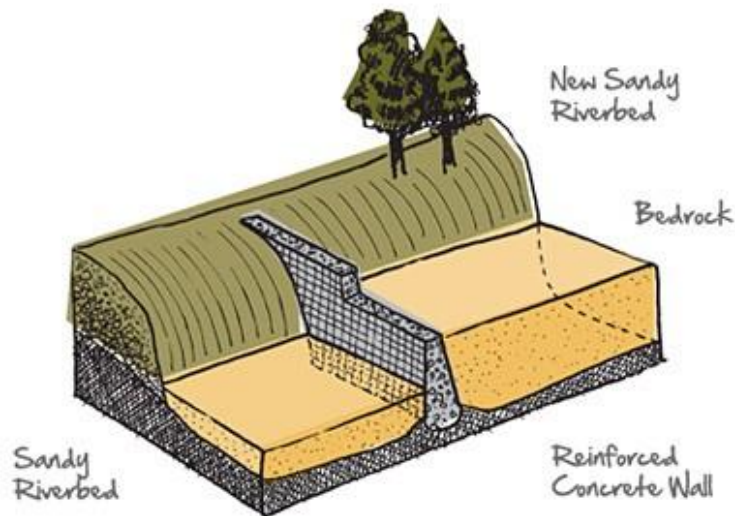

**Figure 1: Sand Dam diagram**

Scoop holes are created by digging into the dam surface until the water table is reached: at which point water is abstracted with a bowl. The wide-bore shallow well is usually located to one side of the sand dam. Before the sediment collects, a perforated pipe is laid and covered with gravel. The pipe leads to a small, protected reservoir on top of which a hand pump is installed. Once the dam is filled with sediment the water collects in the reservoir and may be pumped out (excellent development, 2013).

This study was supported by Africa Sand Dam Foundation, who have built 241 sand dams since 2010, and Excellent Development, who enabled 897 sand dams since 2000.

**Figure 2: A Scoop Hole. Note animal spores and lack of protection.**



**Figure 3: Abstraction From a Wide Bore Shallow Well. The donkey is standing on the sand dam surface.**

Sand dams have been shown to improve access to water during the dry seasons, reduce collection times and result in higher incomes and farm yields for those living in proximity to them (Lasage et al., 2008). However the microbial quality of the water held within them has yet to be assessed.

## WATER QUALITY, SAFETY AND TREATMENT

### Water Quality & Water Safety

#### WHO guidelines for drinking water

*“Safe drinking-water, as defined by the guidelines, does not represent any significant risk to health over a lifetime of consumption, including different sensitivities that may occur between life stages.” (WHO, 2004. pg 1).*

The WHO guidelines detail the water parameters of public health importance focusing on microbial, chemical, radiological and acceptability aspects. This research will focus on microbiological aspects of safe drinking water and use the above guidelines as a reference to assess risks associated with water in sand dams and methods employed for its abstraction. Turbidity was also measured as it can affect the sensitivity of membrane filtration.

The principal health risk associated with microbial contamination of water comes from faecal bacteria (ibid.). Those most at risk of developing illness from ingestion of contaminated water are young children and immunologically compromised individuals (ibid.). High levels of microbial contamination do not always result in sickness due to variation in immune competency (ibid.). Numerous pathogenic organisms can be transmitted through drinking water- as shown in table 1 (taken directly from Demena et. al. 2003 pg 17)

## WATER QUALITY, SAFETY AND TREATMENT

### Water Quality & Water Safety

Table 1: Etiologies of Common Waterborne Diseases, Demena et al 2003 pg 17

“Category of causative agent	Diseases	Causative organism	Common transmission route
<b>Bacterial</b>	Shigellosis	Shigella species	Man-faeces-flies water and food-man
	Typhoid fever	Salmonella typhi and para-typhi	Man-faeces-food and water-man
	Cholera	Vibrio cholerae	Man-faeces-water and food-man
	Acute gastroenteritis	E. coli	Man-faeces-water-man
<b>Viral</b>	Infectious hepatitis	Hepatitis A virus Hepatitis E virus	Man-faeces-water and food-man
	Poliomyelitis	Polio virus	Man-faeces-water-man
	Acute gastroenteritis	Rota Virus	Man-faeces-water-man
<b>Protozoal</b>	Amebiasis	Entameoba hystolitica	Man-faeces-water and food-man
	Giardiasis	Giardia lamblia	Man-water-man”

### Indicator bacteria

It is not practical to test for each pathogenic waterborne organism specifically (WHO, 2004) due to the unique methods needed for their isolation, the fact they are often found in lower numbers than other faecal bacteria (Bartram ed. 1996) and because of their variety. Instead, indicator organisms are used. Indicator organisms are bacteria which fit the following criteria (taken directly from the EPA volunteer estuary monitoring manual 2006, chapter 17, p.g. 17.4)

1. “The organism should be present whenever enteric (intestinal) pathogens are present.
2. The organism should be useful for all types of water.
3. The organism should have a longer survival time than the hardiest enteric pathogen.
4. The organism should not grow in water.
5. The organism should be found in warm-blooded animals’ intestines.
6. The testing method should be easy to perform.
7. The density of indicator organisms should have some direct relationship to the degree of faecal pollution.” (ibid.).

Using indicator bacteria allows one to approximate the level of faecal contamination in a water sample. The indicator bacteria used in this study are thermotolerant coliforms (TTC). TTC are “members of genera or species within the family enterobacterice capable of growth at 44-45°C that possess  $\beta$ -galactosidase.” (Hachich et al., 2012, pg 675) The vast majority of TTC are *Escherichia coli* (ibid.). TTC concentration levels are expressed in TTC/100ml. The WHO guidelines suggest there should be no TTC in drinking water (WHO, 2004). However these guidelines have been considered overly stringent and not applicable to many rural water supplies.

### Context, aims and activities undertaken

#### Aims and Objectives

**Primary aim:** To evaluate the microbiological content of water held within sand dams.

The first objective was to carry out microbial analysis of water held within 29 sand dams, identifying levels of TTC held within them and compare results to WHO guidelines of 0TTC/100ml.

**WATER QUALITY, SAFETY AND TREATMENT**

**Water Quality & Water Safety**

If samples test positive for thermotolerant coliforms, the potential risk associated with contamination levels was indicated based on a WHO sample classification scheme for TTC in water supplies (WHO, 1997)

**Secondary aim:** *To inform practitioners which abstraction method is at the least risk of microbial contamination.*

The same microbial analysis and risk classification carried out on dam water will be used on samples taken at abstraction points. Contamination levels in samples from abstraction points will be compared to contamination levels found in the dam they were abstracting from.

The aim is to illustrate which abstraction method of the two examined shows the least risk of contamination.

**Materials and Methods**

**Study area**

Makueni county is a semi-arid region in eastern Kenya subject to erratic rainfall and long periods of water scarcity (Kenyan government, 2011).

**Sample dam selection**

The depth of the water table in many dams made stratified random sampling impossible. Instead The dams were chosen based on the local knowledge of field co-ordinators who were provided with the following selection criteria

- *Water within three meters of the dam surface.*
- *Only one dam tested per cascade (where more than one dam is built in succession on the same river bed within 2km).*
- *The dam must have been built by the Africa Sand Dam federation. Due to access to user groups and research funding.*
- *Dam surface should not be obscured by water.*

29 dams were selected in total (fig. 4)

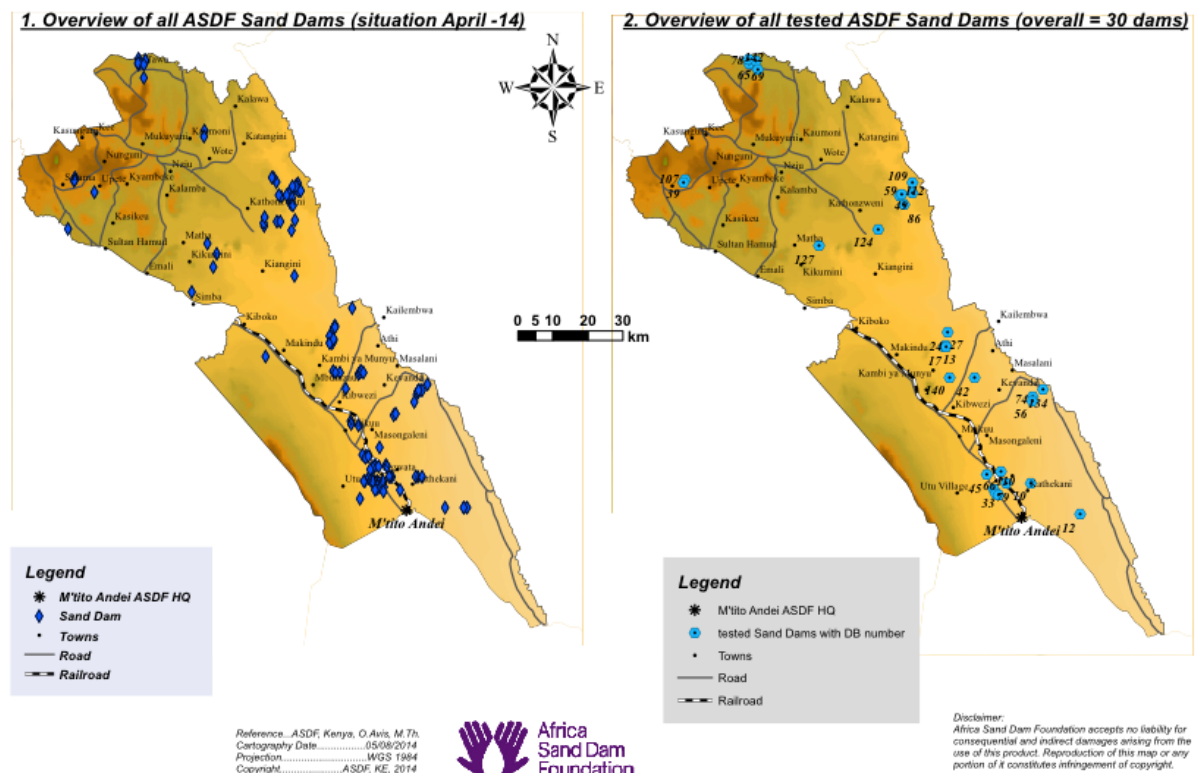

Figure 4 GIS comparing existing dams with those tested

## WATER QUALITY, SAFETY AND TREATMENT

### Water Quality & Water Safety

#### Water sampling methodology

**Test hole** Once the dam was reached a test hole was excavated 50m upstream of the dam wall. 8cm of topsoil was removed from a square of 16m<sup>2</sup> to avoid contamination. A test hole with a circumference of 1.5m was excavated until the water table was reached.

The test hole was dug in a stepped manner, alternating sides as the excavation progressed. This was done so that when water was reached the researcher would be standing on a sand step; avoiding contamination of the sample with shoes.

Upon reaching the water, the digging team cleaned and dried their hands. 20 litres were then abstracted from the test hole using a sterilized bowl and a bucket. Then a 50ml sample was taken for microbial analysis using the sterilised sample cup included in the test kit. A second sample was taken in a jug for testing turbidity.

#### Testing of abstraction methods

**Scoop holes** 25 of the dams tested had scoop holes.

Samples were taken in the same manner that sand dam users would abstract drinking water. At least 20 litres of water were abstracted using a sterile bowl or until the water appeared clear. Then a sample was taken for bacterial analysis using the sterilised cup from the testing kit. A second sample was abstracted to test turbidity.

100ml volumes were filtered for the first three samples, after which 10ml volumes were taken to allow for more accurate enumeration of TTC levels as per test kit guidelines (ibid.).

**Wide bore shallow well with hand pump** Before taking a sample the pump nozzle was flamed with a touch and water was pumped from the well for thirty seconds. Then two samples were taken, in the same manner as above, for microbial analysis and testing of other turbidity levels.

#### Microbial analysis

Microbiological analysis of the sampled water was carried out onsite with the membrane filtration component of the DelAgua™ water testing kit (ibid). The procedure was completed within 15 minutes of the sample being taken.

Firstly, an absorbent pad was placed within a sterilised petri dish and saturated with 2ml of membrane lauryl sulphate broth (MLSB) liquid growth medium. The petri dish was closed, labelled and set aside. The sterilised filtration apparatus was assembled with a 0.45µm cellulose filter membrane in place. The sample was drawn through the membrane using the vacuum pump. The filter membrane was then removed and placed on the absorbent pad in the prepared petri dish.

**Incubation** At least one hour was allowed before incubation for bacterial resuscitation (ibid). No more than 4 hours can elapse between membrane filtration and incubation. If the time between sampling of multiple dams, including one hour for resuscitation, exceeded four hours a second incubator was used. Samples then were incubated for 18 hours at 44°C (± 0.5 °C).

**Enumeration** Samples were removed from the incubator and yellow bacterial colonies were counted (fig:5). The count from a 50ml sample was multiplied by two to give a thermotolerant coliform (TTC) value per 100ml. Similarly, the count from a 10ml sample was multiplied by 10.

## WATER QUALITY, SAFETY AND TREATMENT

### Water Quality & Water Safety



Figure 5

Counts of colony forming units on the filter membrane above 80-100 can only be estimated due to competition for nutrients and the overlapping of colonies. Because of this, scoop hole samples were generally 10ml (ibid).

### Other indicators of water quality

Turbidity was measured in nephelometric turbidity units (NTU) using the turbidity tube provided in the test kit (ibid.).

### Data analysis

Results from water abstracted from test holes, scoop holes and shallow wells were assessed using the analytical tests as those detailed below.

### Comparison with WHO guidelines

**TTC** Microbial water quality was assessed based on a WHO example classification for TTC in drinking water, which matches numbers of TTC per 100ml with their associated risk (table 1). The original WHO classifications were modified to avoid overlapping categories (WHO, 1997, pg 78).

Table 2: WHO Microbiological Risk Classification (1997)

TTC per 100ml	Level of Risk
0	None: in conformity with WHO guidelines
1-10	Low risk
11-100	Intermediate risk
101-1000	High risk
1000	Very high risk

**Turbidity** Results expressed using descriptive statistics were used to demonstrate the proportion of samples meeting the WHO criteria of <1NTU (WHO, 2004).

### Comparison of abstracted water with test hole water.

The secondary research aim was to test which abstraction technique best maintained the water quality of the dam. Two abstraction methods were assessed, scoop holes and shallow wells.

Results from TTC, turbidity tests are skewed and specific tests were needed.

Separate tests were carried out that compared samples from each abstraction point with its corresponding test hole sample from the same dam. Results from each were converted into binary variables based on values falling above each WHO risk associated cut-off points of 0, 10, 100, and 1000TTC/100ml.

McNemar's test assesses the probability that the difference between proportions in each category falling above or below the cut-off point is due to chance (Armitage et al., 2005).

### Main results and lessons learnt

#### Results



## WATER QUALITY, SAFETY AND TREATMENT

### Water Quality & Water Safety

#### Test hole results

##### Thermotolerant coliforms

The primary focus of this research was to assess the microbial quality of the water held within sand dams. A total of 29 dams were tested. 83% of samples had 0 TTC/100ml. 6.9% of samples tested positive for 1TTC/100ml, a further 6.9% tested positive for 2TTC/100ml, and one sample had 3TTC/100ml (table 3).

Table 3: Frequency of TTC/100ml in Test Hole Samples

Thermotolerant coliforms	Frequency	Percentage
0	24	82.76%
1	2	6.90%
2	2	6.90%
3	1	3.45%
Total:	29	100%

The skewness coefficient of 2.59 indicates the results are significantly skewed to the right, with the majority of samples testing negative for TTC and a few testing positive (Kirkwood et al, 2003). Due to this, the median (0) and interquartile range (0-0) are the best indicators of distribution and non-parametric tests must be used for analysis.

Table 4 Summary Statistics of TTC/100ml in Test Hole Samples

Sample Size	Skewness coefficient	Min. value	Lower Quartile	Median	Upper quartile	Max. Value
29	2.59	0	0	0	0	3

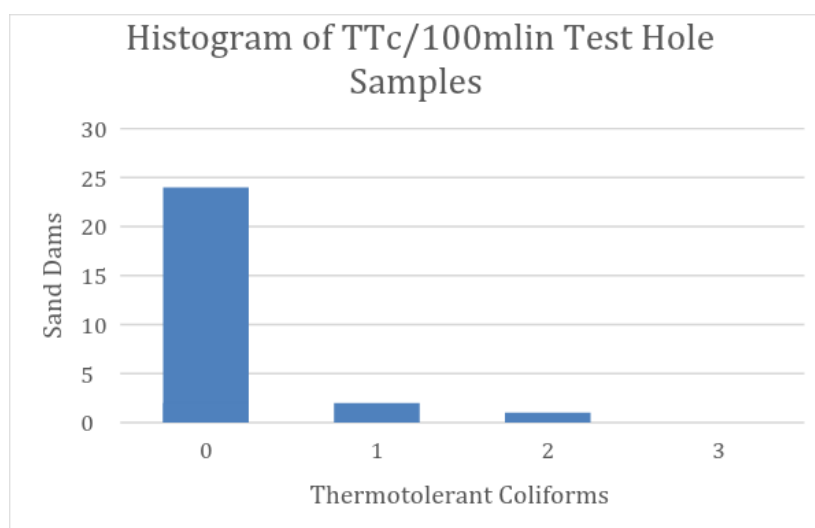

Figure 6: Histogram of TTC/100ml in Test Hole Samples (demonstrating results are skewed to the right).

##### Comparing TTC/100ml with WHO guidelines

**Thermotolerant coliforms** 82.8%, of the samples abstracted from test holes tested negative for TTC in accordance with the WHO parameters of 0 TTC/100ml for drinking water (WHO 4<sup>th</sup> ed., 2011). 17.24% are within in the suggested low risk category (WHO 2<sup>nd</sup> ed. vol. 3 ,1997).

Table 5 Risk Classification comparison with TTC/100ml in test holes.

**WATER QUALITY, SAFETY AND TREATMENT**

**Water Quality & Water Safety**

<b>WHO microbiological risk classification scheme (WHO vol. 3 2<sup>nd</sup> edition, 1997, pg 78)</b>		
Percentiles from this study	TTC per 100ml	Level of risk
82.76%	0	None: in conformity with WHO guidelines
17.24%	1-10	Low risk
0%	11-100	Intermediate risk
0%	101-1000	High risk
0%	1000	Very high risk
N/A	0.3	Cut-off based on the likely sample mean

**Turbidity in test holes**

Turbidity results were also negatively skewed. The median is 30NTU with an interquartile range from 15NTU to 70NTU. The lowest value is given here as 5NTU or less. The turbidity tube could not measure below 5NTUs (Del Agua, 2009) (Armitage et al., 2005).

**Scoop hole results**

**TTCs in scoop holes**

The secondary question of this research is to establish which abstraction method best maintains the water quality present in the dam.

25 water samples were taken from scoop holes. Contamination levels were positively skewed with 75% of samples falling between 110 and 770TTC/100ml while the highest value was approximately 3865 TTC/100ml.

*Table 6: Summary Statistics of TTC/100ml in Scoop Holes*

Sample size	Skewness	Min value	Lower quartile	Median	Upper quartile	Max value
25	1.51	0	110	260	770	3865

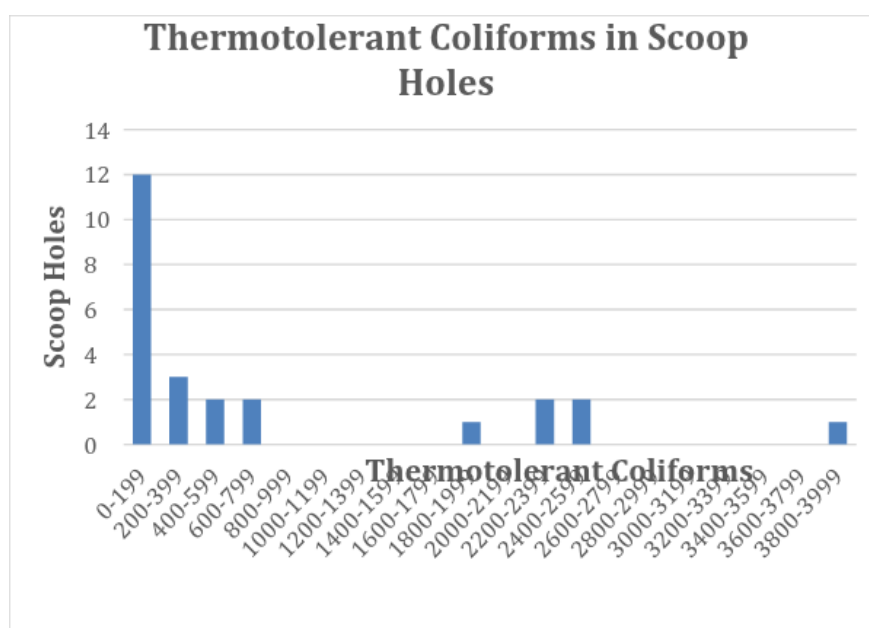

**WATER QUALITY, SAFETY AND TREATMENT**

**Water Quality & Water Safety**

Figure 7: Histogram of TTC/100ml in Scoop Holes

**Comparison of scoop hole TTC results with the WHO guidelines for risk-free drinking water**

Only two samples conformed with WHO guidelines for drinking water: testing negative for TTC. 52% of samples tested between 101-1000 TTC/100ml, indicating a high risk of contamination (WHO, 1997). 24% of samples represented a very high risk at more than 1000 TTC/100ml (Armitage et al., 2005).

Table 6: Classifying risk associated with TTC/100ml in Scoop Holes, .WHO Microbiological risk classification scheme (WHO vol. 3 2nd edition, 1997)

Percentiles from this study	Samples (n=25)	TTC per 100ml	Level of risk
8%	2	0	None: in conformity with WHO guidelines
0%	0	1-10	Low risk
12%	3	11-100	Intermediate risk
52%	13	101-1000	High risk
24%	6	>1000 (estimate)	Very high risk

**Comparing TTC/100ml between scoop and test hole samples of the same dam using McNemar’s chi-square statistic**

McNemar’s test allows for the comparison of the differences of paired binomial proportions (Petrie et al., 2013 ). The TTC/100ml in dam and scoop hole samples was made into binary data using the cut-off points from the WHO risk classifications (see table 19 below). There were 23 sand dams tested that also had a scoop hole. The test examines if the difference between discordant pairs- i.e. TTC/100ml results from scoop holes- are positive and test holes are negative in the same dam, or vice versa, is due to chance or is significant (Armitage et al., 2005).

**Null hypothesis (Ho):** There is no statistically significant difference in the proportions of TTC/100ml above and below the cut-off values between these two abstraction methods.

**Alternative hypothesis (Ha):** There is a statistically significant difference in the proportions of TTC/100ml above and below the cut-off values between these two abstraction methods.

At cut off points 0, 10, and 100 there is strong evidence (p=0.000) to reject the null hypothesis- indicating a significant difference in the proportions of samples above the cut-off point and below the cut-off point in between the two abstraction types. Another way of phrasing this would be that the proportion of samples above the contamination threshold is significantly higher in one abstraction method, the scoop hole, than the other, the test hole. At the 1000 TTC/100ml cut-off point the null hypothesis is accepted (p=0.0625), indicating no difference in the proportions of samples above the cut-off point and below the cut-off point in each abstraction type. This is likely due to the small number of scoop hole samples above this cut-off point.

In every comparison there are more scoop hole samples with TTC/100ml values above the cut-off point than test hole samples above the cut-off point (as demonstrated in the right two columns of table 18).

This indicates that when there is a discordance it is a result of TTC/100ml in the scoop hole samples exceeding the cut-off point rather than TTC/100ml levels in the test hole samples doing so.

Table 7: A Comparison of TTC/100ml in Paired Scoop and Test Holes

McNemar’s test statistic comparing discordance between scoop and test hole TTC/100ml						
N=23	Binary cut-off points	Number of discordant pairs	P value (1)/ exact McNemar significance probability (2)	Accept/reject Ho	Test hole samples with TTC/100ml values above the cut-off point	Scoop hole samples with TTC/100ml values above the cut-off point
	0TTC	17	0.0000 (2)	Reject Ho	4	21
	10TTC	21	0.0000 (1)	Reject Ho	0	21

## WATER QUALITY, SAFETY AND TREATMENT

### Water Quality & Water Safety

	<b>100TTC</b>	17	0.0000 (2)	Reject Ho	0	17
	<b>1000TTC</b>	5	0.0625 (2)	Accept Ho	0	5

Source: <http://www.ats.ucla.edu/stat/stata/whatstat/whatstat.htm>

#### McNemar's test at 0TTC/100ml

An example of a two by two table created to carry out McNemar's test at the 0TTC/100ml cut-off point. The discordant pairs (17 and 0) are in bold. There are 21 scoop hole samples above the 0TTC/100ml threshold. In the test hole only four samples contained TTCs.

Table 8: An example 2 by 2 table for McNemar's Test.

McNemar's test at 0TTC/100ml		Test hole		
		+	-	Total
Scoop hole	+	4	<b>17</b>	21
	-	<b>0</b>	2	2
	Total	4	19	23 (n)

#### Turbidity in scoop holes

The median NTU of the 25 samples is 27 with an interquartile range from 10 to 32NTU (see table below). Only 3 samples showed NTUs less than 5. No samples showed turbidity above 100NTU. The distribution is positively skewed as demonstrated by the skew coefficient.

Table 9: Summary Statistics of NTU in Scoop Hole Samples

Sample size	Skewness	Min value	Lower quartile	Median	Upper quartile	Max value
25	1.11	<5	10	27	32	100

#### 4.3 Shallow well results

##### Thermotolerant coliforms in shallow wells

Eight shallow wells were tested with a median value of 1TTC/100ml and an interquartile range of 0 to 44 TTC/100ml. 76 and 0TTC/100ml were the highest and lowest values respectively. The distribution of data is positively skewed; as shown by the skew coefficient 1.32

Table 10: Summary Statistics of TTC/100ml in Shallow Wells

Sample size	Skewness	Min value	Lower quartile	Median	Upper quartile	Max value
8	1.32	0	0	1	44	76

Table 11: Frequency of TTC/100ml in Shallow Well Samples

TTC	Frequency (n=8)	Percent
<b>0</b>	3	37.5%
<b>1</b>	2	25%
<b>18</b>	1	12.5%
<b>70</b>	1	12.5%
<b>76</b>	1	12.5%
<b>Total</b>	<b>8</b>	<b>100%</b>

Three of the eight samples conformed with the 0 TTC/100ml guidelines suggested by the WHO. Two or 25% of samples are deemed low risk and three samples had intermediate risk- falling between 11 and 100 TTC/100ml.

Table 12: Potential Risk Associated with TTC/100ml in Shallow Well Samples

WHO microbiological risk classification scheme (WHO vol. 3 2 <sup>nd</sup> edition, 1997, pg77)			
TTC per 100ml	Samples (n=8)	Percentiles	Level of risk

## WATER QUALITY, SAFETY AND TREATMENT

### Water Quality & Water Safety

		from this study	
0	3	37.5%	None: in conformity with WHO guidelines
1-10	2	25%	Low risk
11-100	3	37.5%%	Intermediate risk
101-1000	0	0%	High risk
>1000	0	0%	Very high risk

### Comparing TTCs/100ml in samples from test holes and shallow wells of the same dam

Eight shallow wells were assessed against test holes with McNemar's test. No difference was found between TTC/100ml in test holes and shallow wells ( $p = 0.50-1.0$ ). There is strong evidence to accept the null hypothesis in all samples.

Table 13: Comparison of TTC/100ml Between Paired Shallow Well and Test Hole Samples

N=8	Binary cut-off points	Number of discordant pairs	Exact McNemar significance probability	Accept/reject Ho	Test hole samples with TTC/100ml values above the cut-off point	Scoop hole samples with TTC/100ml values above the cut-off point
	0TTC	2	0.50	Accept Ho	1	3
	10TTC	2	0.50	Accept Ho	0	2
	100TTC	0	1.00	Accept Ho	0	0
	1000TTC	0	1.00	Accept Ho	0	0

### Turbidity levels in shallow wells

The median turbidity of the eight samples was 5NTU with an interquartile range from 5 to 7.5NTU (see table below). Only six samples showed turbidity less than 5NTU, while the remaining two had turbidity of 10.

## Discussion

### Is water held in sand dams fit for human consumption?

The primary objective of this research was an evaluation of the microbial content of water in sand dams. This was assessed for compliance to WHO guidelines, TTC/100ml and, (WHO, 1997). Evidence indicates water within sand dams represents minimal to no health risk., Additional research detailed in the final section of this paper would make such conclusions more robust.

### Test holes

TTC Faecal bacteria present the most significant health risk from microbially contaminated drinking water (WHO, 2004).

The amount of TTC/100ml in many water sources are skewed in their distribution, with few samples heavily contaminated and most free of coliforms. As such, the median and interquartile range is the best measure of distribution. All these values were 0TTC/100ml in the sample population. The estimate of the true population median lying between 0.0000000000001 and 0.49 TTC/100ml is the result of five positive samples test hole samples. While WHO guidelines state drinking water should have no TTC/100ml present it is widely understood that such targets may not be attainable in many countries (Parker et. al., 2010). Uganda has set its limit to 50TTC/100ml of drinking water and Swaziland to 10TTC/100ml

## WATER QUALITY, SAFETY AND TREATMENT

### Water Quality & Water Safety

(ibid.). In comparison, the levels found within sand dams are very low. Further research, done through expanding population sizes and covering more regions where sand dams are present, may make such findings more robust.

A combination of factors could have led to an artificially high estimated median TTC/100ml value. Firstly, the testing procedure was invasive. The sample could have been contaminated by an outside source such as the footwear or hands of the person digging. Excavation of the test hole often took an hour. Furthermore, the surface of all dams had significant numbers of animal droppings on them. Winds often blew particles from the dam surface into the test hole. It was also difficult to prevent sand falling into the test hole as it was being dug or scooped.

Four of the first five samples tested positive for TTC (fig 17). Only one other sample hole tested positive. This is possibly due to the fact that this technique has never been tried before and was new to the research team.

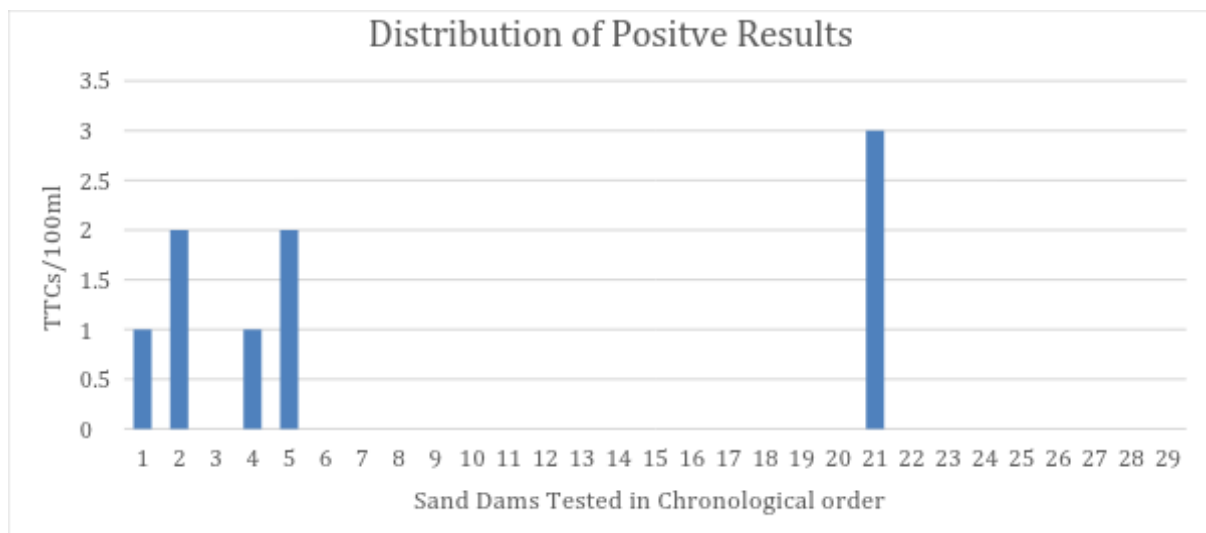

Figure 8: Chronological Distribution of TTC Positive Samples in Test Holes

It is also possible that this study underestimated the number of TTC/100ml in test hole water. If this is the case, the most likely reason is due to the use of membrane filtration (MF). MF is not suited to the high turbidity levels present in almost all samples abstracted from the sand dam. LeChevallier (1981) suggested a masking effect when using MF to measure TTCs in turbid water after chlorination. However, this is based on contaminated chlorinated water and he did not specify the makeup of the particles causing the turbidity. In 1975, the environmental protection agency indicated that the principal reasons for avoidance of MF for assessment of turbid water “relates to volumes that can be filtered, character of suspended material and thickness of the suspended material that deposits on the membrane filter surface” (Geldrich, 1975, pg 13). On the nature of the suspended material they comment “ferrous, manganese, and alum flocs may clog filter pores or cause a confluent film to develop during incubation. Thick surface layers of crystalline or siliceous materials may cause little or no difficulty” (ibid.) Suspended particles usually originate from materials surrounding them (ibid.). The test holes were excavated at the centre point of the sand dam. The sand of inland waterways is commonly constituted of silica (Pettijohn, 1904). Therefore, it is possible that the turbidity of test hole samples may not have significantly altered the test results. Furthermore, no test was attempted in which the filter was clogged during filtration.

### Turbidity

The turbidity of sampled water from test holes was high. It had a sample median of 30NTU.

### Scoop hole water quality

## WATER QUALITY, SAFETY AND TREATMENT

### Water Quality & Water Safety

Scoop holes tested in this research do not produce water safe for human consumption. 52% of samples were classified as high risk and 24% as very high risk with faecal bacteria present in excess of 1000TTC/100ml (WHO, 1997). The sample median was 260TTC/100ml. As previously mentioned, the effect this will have on an individual varies according to immune competency. However, it has been shown that healthy individuals consuming pathogens at levels often present in such highly contaminated water do become sick (WHO, 2004).

Test holes are hygienically excavated scoop holes. This suggests the contamination of scoop holes is related to the manner in which they are dug their age or usage. While patterns of use are beyond the scope of this research, contamination could arise from human contact, animal contact and water runoff (Cairncross 1998).. The lack of sanitary water collection methods are likely to have contributed to contamination. Most scoop holes had no fencing, allowing livestock to drink directly from them. Water running from the soiled surface of the dam into the scoop hole may have contributed to contamination levels. This is likely to be more significant during seasonal rains, however there may be less reliance on sand dams during these times.



Figure 9: A Cow Drinking from a Scoop hole. Note empty water containers.

A tenfold reduction in TTCs would still leave 24% of samples in the WHO high-risk category<sup>153</sup>. For the above reasons, and the scale of contamination, it is unlikely that methodological flaws could result in the misclassification of scoop holes as high-risk.

### Shallow wells

Only eight of the dams tested had shallow wells; too small a sample size from which to draw statistically sound conclusions. The water was generally of better quality than that of scoop holes. Three samples tested negative for TTCs while two produced samples with a single TTC/100ml; indicating a low associated risk (WHO, 1997). The remaining three samples (which had 18, 70 and 76 TTC/100ml) indicated an intermediate risk (ibid.). There was no evidence against a hypothesised population median of 10TTC/100ml. However, there was statistical evidence against median estimates of 0, 100, and 1000 ( $p>0.05$ ). No statistical evidence ( $p>5$ ) was found signifying a difference in median TTC/100ml between test holes and shallow wells.

Shallow well samples had a median turbidity of 5NTU, lower than other forms of abstraction. There is an association between turbidity and pathogenic bacteria.

<sup>153</sup> 100 or more TTC/100ml.

## WATER QUALITY, SAFETY AND TREATMENT

### Water Quality & Water Safety

Further research is needed to establish if water abstracted from sand dams using a shallow well is low-risk. Several of the shallow wells tested had signs of wear including cracks in the apron and pooling in the drainage channel; both of which represent risk factors for contamination (Parker et al., 2010).

Tested shallow wells are protected and display fewer risk factors for contamination than sample holes, however the small sample size limits the significance of these findings.

#### Limitations

Time constraints dictated the study type. Cross-sectional studies are relatively fast and relatively inexpensive. They are, however, ineffective at examining aetiology as assumptions as to why dams or scoop holes are contaminated must be made with caution (Carneiro et al., 2011). However, bacterium needs no counterfactual (Cairncross, personal conversation). Risk is derived from its presence of TTCs not the mechanism by which it arrived there.

Microbiological water quality can fluctuate rapidly throughout the day as use changes (ibid.). It would have been interesting to examine such changes in scoop holes and shallow wells, however the team were limited by time and resources.

Water quality varies throughout the year, especially immediately before and after the rainy seasons when rain water runoff can increase the likelihood of water supply contamination (Parker et al., 2010) (Howard et al., 2003). Further research is examining the impacts of seasonality on sand dam water.

A larger sample size would add weight to the findings of this research. The main barrier to achieving this within this research was time spent digging and difficulty in reaching the water table.

#### Conclusions and Recommendations

The vast majority of test holes sampled in this research meet TTC/100ml WHO recommendations of 0TTC/100ml suggesting no risk to human health from waterborne pathogens. Few dams were minimally contaminated and may not represent a significant health risk (WHO, 1997). This indicates the water held within sand dams is generally of good quality.

Maintaining this inherent quality during abstraction is challenging. Of the two abstraction methods assessed, shallow wells seem to offer less contaminated water with lower turbidity levels. However, this was based on a small sample size (n=8). Organisations in Kenya and Zimbabwe are currently undertaking further research on this matter, and so far results support the findings of this document. Furthermore, wide bore shallow wells provide water later into the dry season when the water table is too low to be reached by a scoop hole. Installations and maintenance costs of shallow wells must be considered by implementers.

Water samples from scoop holes suggest levels of faecal contamination that may represent a significant health risk. This finding is reinforced by comparing it with contamination in unprotected hand-dug wells<sup>154</sup>. Water quality may be improved through adoption of hygienic practices and building barriers against livestock entry. However, scoop holes are, by their nature, prone to contamination (ibid.). While test holes are, in essence, hygienically dug scoop holes it may be impractical to suggest new scoop holes are dug each time water is collected- considering the depth of the water table through much of the year. That said, considering reported levels of hand pump failure across the continent, scoop holes provide a valuable auxiliary abstraction method.

Sand dams without alternate means of abstraction do not represent failure. There are numerous benefits to having a reliable water source, including reduced collection journey times and increased water quantity used. This is likely to be of greater health importance of water quantity than water quality (Cairncross, 1998). While it is important to establish whether a water intervention puts people at risk of waterborne disease, the greatest health impact is likely to result from a sand dam which provides accessible water throughout the dry season. Some do not. Accordingly, efforts that aim to improve sighting and construction of sand dams to increase and prolong their productivity will have greater impact on user health than those aimed at ensuring pristine water is abstracted.

---

<sup>154</sup> [http://www.who.int/water\\_sanitation\\_health/hygiene/emergencies/fs2\\_2.pdf](http://www.who.int/water_sanitation_health/hygiene/emergencies/fs2_2.pdf)



## WATER QUALITY, SAFETY AND TREATMENT

### Water Quality & Water Safety

It is well known that transport and storage practices affect water quality. Ensuring sand dam water is free of pathogenic organisms does not guarantee it is uncontaminated at point of use. However, a multi barrier protection is considered the best defence against contamination of drinking water (WHO, 2004).

### Acknowledgements

*Sandy Cairncross OBE: Who acted as my advisor*

*Dr. Jeroen Ensink; Who trained me to use the del Agua test kit and generally guided and helped me far more than he should have.*

*Dr. Matt Yeo: Who's patience and ingenuity were essential to the project.*

*Johannes Nettesheim: who dug and dug and dug.*

*Bernard Ngeindolo: Our driver*

*Veronica Mwikali: our research assistant.*

### References

- Armitage P. (2005) '*Statistical methods in medical research 4<sup>th</sup> edition*' Blackwell publishing
- American public health association (1999) 'Standard methods for the examination of water and waste water' [online] Available at: [http://www.mwa.co.th/download/file\\_upload/SMWW\\_1000-3000.pdf](http://www.mwa.co.th/download/file_upload/SMWW_1000-3000.pdf) [Accessed 14 Sep. 2014].
- Bartram J. Ballance, eds. (1996), '*Water quality monitoring: a practical guide to the design and implementation of freshwater quality studies and monitoring programs.*' [online] Available at: [http://www.who.int/water\\_sanitation\\_health/resourcesquality/wqmonitor/en/](http://www.who.int/water_sanitation_health/resourcesquality/wqmonitor/en/) [Accessed 14 Sep. 2014].
- Bartram J. (2012), '*annual waste water quality and human health*'. [online] Available at: [http://www.who.int/water\\_sanitation\\_health/publications/2012/ch1.pdf](http://www.who.int/water_sanitation_health/publications/2012/ch1.pdf) [Accessed 14 Sep. 2014].
- Carneiro et al. (2011) '*Introduction to Epidemiology*' open university press
- Cairncross et al. (1991) '*Evaluation of village water supply Planning*'. International reference center for community water supply and sanitation.
- Cairncross, Feachem, (1998) '*Environmental health engineering in the tropics second edition*' wiley
- Demena et al (2003) '*Water borne disease*' [online] Available at: <http://www.cartercenter.org/resources/pdfs/health/ephti/library/modules/WaterBorneDisease.pdf> [Accessed 14 Sep. 2014].
- Del Agua (2009) 'del agua test kit manual' [online] Available at: [online] Available at: [http://www.who.int/water\\_sanitation\\_health/resourcesquality/wqmonitor/en/](http://www.who.int/water_sanitation_health/resourcesquality/wqmonitor/en/) [Accessed 14 Sep. 2014]./ [Accessed 14 Sep. 2014].
- Environmental protection Agency (2006) '*Volunteer estuary monitoring manual 2<sup>nd</sup> ed.*' [online] Available by at: [http://water.epa.gov/type/oceb/nep/upload/2009\\_03\\_13\\_estuaries\\_monitor\\_chap17.pdf](http://water.epa.gov/type/oceb/nep/upload/2009_03_13_estuaries_monitor_chap17.pdf) [Accessed 10 October 2009].
- Environmental protection agency (2012) '*monitoring and Assessment: 5.9 conductivity*' [online] Available by at: <http://water.epa.gov/type/rsl/monitoring/vms59.cfm> [Accessed 10 October 2009].
- Excellent Development, (2013), '*Building sand dams a practical guide*'. [online] Available by request at: <http://www.excellentdevelopment.com/sand-dam-manual> [Accessed 10 October 2009].
- Geldreich et al (1975) '*interferences to coliform detection e evolution of the microbiology standards of drinking water*'. Environmental protection agency.
- FAO (2007) '*coping with water scarcity: challenges of the 21<sup>st</sup> century*'. [online] Available at: <http://www.fao.org/nr/water/docs/escarcity.pdf> [Accessed 14 Sep. 2014].
- Government of Kenya (2011) '*The 2011 long rains season assessment report*' Kenya food security steering group (KFSSG)
- Hachich, E. M et. al. (2012). '*Comparison of thermotolerant coliforms and Escherichia coli densities in freshwater bodies*' *Braz J Microbiol*, 43, 675-81.
- Howard, G. et al. (2003). '*Risk factors contributing to microbiological contamination of shallow groundwater in Kampala, Uganda*.' *Water Research*, 37, 3421-3429
- Lasage, R. et al. VRIES, A. (2008). '*Potential for community based adaptation to droughts: Sand dams in Kitui, Kenya*.' *Physics and Chemistry of the Earth, Parts A/B/C*, 33, 67-73.

## WATER QUALITY, SAFETY AND TREATMENT

### Water Quality & Water Safety

- LeChevallier et al. (1981) 'Effect of turbidity on chlorination efficiency and bacterial persistence in drinking water *applied and environmental microbiology*' 42(1) pg 159-167.
- Mwanzi (2010) 'Assessment of ground water potential in makueni subcounty Kenya' [online] <http://erepository.uonbi.ac.ke/bitstream/handle/11295/69933/KIOKO%20JEHOSHAPHAT%20MWANZIA.pdf?sequence=2> Accessed 14 Sep. 2014].
- Nkansah, M. et al. (2010) 'Assessment of the quality of water from hand-dug wells in Ghana.' *Environmental health insights* 47- 12. <http://www.ncbi.nlm.nih.gov/pmc/articles/PMC2879609/pdf/ehi-2010-007.pdf>
- Population Action International, (2011) 'population dynamics, environment and sustainable development in Makueni County' [online] Available at: [http://populationaction.org/wp-content/uploads/2014/07/PAI\\_Makueni.pdf](http://populationaction.org/wp-content/uploads/2014/07/PAI_Makueni.pdf) [Accessed 14 Sep. 2014].
- Parker et al. (2010) 'An assessment of microbiological water quality of six water source categories in north-east Uganda.' *Journal of water and health* 8(3)
- Petrie, A. Sabin C (2009) 'medical statistics at a glance third edition.' wiley-blackwell
- Pettijohn et al (1904) 'Sand and sand stone 2<sup>nd</sup> edition' Springer-Verlag New York
- UN, (2002) 'Rights to water and sanitation' [online] available at: <http://www.righttowater.info/progress-so-far/general-comments-2/> [Accessed 14 Sep. 2014].
- UN, (2014a) 'The human right to water and sanitation' [online] Available at: [http://www.un.org/waterforlifedecade/human\\_right\\_to\\_water.shtml](http://www.un.org/waterforlifedecade/human_right_to_water.shtml) [Accessed 14 Sep. 2014].
- UN, (2014b) 'millennium development goals' [online] available at [www.un.org/millenniumgoals/](http://www.un.org/millenniumgoals/) [Accessed 14 Sep. 2014].
- UN, (2014c) 'Water for life decade: water scarcity' [online] available at <http://www.un.org/waterforlifedecade/scarcity.shtml> [Accessed 14 Sep. 2014].
- UN, (2005) 'The Millennium development goals in africa: Progress and prospects' [online] <http://www.un.org/africa/osaa/reports/MDGs%20A%20Graphical%20Illustration%20of%20progress%20and%20progress.pdf> [Accessed 14 Sep. 2014].
- UN, (2012) 'The millennium development goals report 2012' [online] available at [www.un.org/millenniumgoals/pdf/MDG\\_Report\\_2012.pdf](http://www.un.org/millenniumgoals/pdf/MDG_Report_2012.pdf) [Accessed 14 Sep. 2014].
- UN, (2013) 'UN water the world water day 2013' [online] available at <http://www.unwater.org/water-cooperation-2013/water-cooperation/facts-and-figures/en/> [Accessed 14 Sep. 2014].
- UN, (2015) 'The Millennium Development Goals Report' [online] available at [http://www.un.org/millenniumgoals/2015\\_MDG\\_Report/pdf/MDG%202015%20rev%20%28July%201%29.pdf](http://www.un.org/millenniumgoals/2015_MDG_Report/pdf/MDG%202015%20rev%20%28July%201%29.pdf) [Accessed 04 May 2015].
- WHO (2004) 'Guidelines for drinking-water quality: fourth edition' [online] available at [http://whqlibdoc.who.int/publications/2011/9789241548151\\_eng.pdf?ua=1](http://whqlibdoc.who.int/publications/2011/9789241548151_eng.pdf?ua=1) [Accessed 14 Sep. 2014].
- WHO (1997) 'Guidelines for drinking-water quality second edition, volume 3 surveillance and control of community supplies' [online] [http://www.who.int/water\\_sanitation\\_health/dwq/gdwqvol32ed.pdf](http://www.who.int/water_sanitation_health/dwq/gdwqvol32ed.pdf) [Accessed 14 Sep. 2014].

## WATER QUALITY, SAFETY AND TREATMENT

### Water Quality & Water Safety

# Enrichment of iron in the Gannoruwa well field: Causes and pathways

## K.M. PREMATILAKA.

Assistant General Manager (Groundwater),  
National Water Supply and Drainage Board  
Telawala Road, Rathmalana.

## INTRODUCTION

The excessive concentration of iron in drinking water is one of the wide-spread hydrogeochemical problems in Sri Lanka, particularly in groundwater drawn from the bore hole wells located within the alluvial sand deposits. When iron content is high in water, the quality of drinking water is poor due to unpleasant taste, color and odor. Alluvial sandy aquifers are very useful as sources of water supply bore holes wells particularly for Rural Water Supply Schemes in Sri Lanka. About 10 % of the sources of rural water supply schemes, based on these aquifers scattered around Sri Lanka are affected by iron enrichment. Iron enrichment in groundwater is largely controlled by the natural environment and there are large numbers of drinking water wells affected by the iron enrichment, National Water Supply and Drainage Board of Sri Lanka carry out necessary treatment methods to improve water quality.

The present study has focused on causes and pathways of iron enrichment with in the Gannoruwa well field which is situated in an unconsolidated alluvial sand deposit on the left bank floodplain of the Mahaweli river at Peradeniya (figure: 1.1). The extent of the sand deposit is about 35,000 square meters and the average elevation of the area is 470 m above mean sea level. In this well field, three productive boreholes (TW2, TW3 and TW5) have been constructed during 1989 to supply drinking water to Gohagoda area. During the initial testing stage, iron concentration of the three wells of TW 2, TW 3, and TW 5 varied from 0.01 to 0.03 mg/l. The pH of the groundwater was varied from 6.1 to 6.5.

These three boreholes have been in operation since 1994 and the total pumping capacity per day is about 2000 cubic meters per day. The usual pumping rates of TW 1, TW 2 and TW 5 are 30 m<sup>3</sup>/h, 30 m<sup>3</sup>/h, and 24 m<sup>3</sup>/h respectively. The water quality monitoring has revealed that iron concentration of the bore hole wells has increased with time. After ten years, iron concentration of borehole TW 5 situated 58 m away from the river has shown a very high value, an average of 3.00 mg/l, compared with the other wells. Whereas TW 2 and TW 3 has shown iron concentrations of 0.12 and 0.15 mg/l respectively. Iron concentration of the river has also varied with time monitored during the period between 1993 and 2008. The maximum iron concentration of 0.95 mg/l has been recorded in October, 1995 and the lowest iron concentration of 0.11 mg/l in January 2001. However; iron concentration variation in the river water does not show any relationship with that of the borehole wells.

With the increasing water demand of the area, five new shallow bore holes (TW4, TW6, TW7, TW8 and TW9) were drilled in the same well field in 2000. These new wells are situated closer to the river with respect to other existing wells. The flushing yields of the new wells located closer to the river were higher (more than 2000 l/min.) compared to the other wells. The iron concentration in all new wells was above the 1 mg/l norm of Sri Lanka Standard guideline. Therefore, these wells are not in use at present. The present study reveals the causes, distribution and path ways of iron in groundwater of the Gannoruwa well field.

## METHODOLOGY

In order to study the iron problem in the well field, a simultaneous pump testing program (72 hours) was launched on four shallow productive wells (TW2, TW3, TW4 and TW5) with a rate of 122 m<sup>3</sup>/hour.

## WATER QUALITY, SAFETY AND TREATMENT

### Water Quality & Water Safety

Water samples were collected every three hour intervals during pumping and fourteen water samples were also collected from the Mahaweli River during the testing period. Eh, pH and temperature of the samples were measured at the site and total iron, manganese, colour, turbidity and conductivity were measured in the laboratory. The Eh and pH values were plotted on the stability-field diagram (Hem, 1959/1985) for a  $10^{-6}$  molal solution of iron to determine the ferric ( $\text{Fe}^{3+}$ ) and ferrous ( $\text{Fe}^{2+}$ ) states at different time intervals.

## RESULTS AND DISCUSSION

### Hydrogeology and Geochemistry of the Gannoruwa Well Field

The alluvial deposit having a thickness varying from 10.30 m to 18.00 m consists of fine to gravelly sand, pebble and clayey top soil is underlain by the Precambrian metamorphic rocks. One boundary of the deposit is Mahaweli River and the sandy and gravelly layers are confined to the river meander, the lower part of the alluvial deposit acting as an unconfined aquifer. Thickness of this aquifer formation varies from place to place with a maximum of 8 m. The iron Generally, average iron concentration of the wells under different pumping conditions and distance from the river shows a negative correlation based on the (Figure:2.1).

### Behavior of water quality during pumping

During the pumping period, Eh values have varied from +0.260 to -0.125 V (figure:2.2) pH varied from 7.32 to 6.45 (figure:2.3). TW 2, TW 03 and river water showed positive Eh values. TW 05 showed negative Eh values during the total testing period and TW 04 initially showing positive Eh values (+0.260v) changed to negative values (-0.090v) during pumping. However, pH has not varied with pumping time. The average values of electrical conductivity of groundwater and river water were 100  $\mu\text{S}/\text{cm}$  and 60  $\mu\text{S}/\text{cm}$  respectively. The variation of iron in the pumping wells and river during the testing period is shown in figure (2.4). The iron concentration only in TW 4 showed a significant variation during pumping. The manganese content has varied from 0.1 to 0.8 mg/l. The water temperature (26-27  $^{\circ}\text{C}$ ) in all wells and river water did not vary with pumping time.

### Hydrogeological characterization of the iron problem

The part of the well field where TW 04, TW 5, TW 8, TW 6, and TW9 are located has high concentration of total iron in the groundwater while the other part of the well field where TW 02, TW 3 and TW 7 are located, had low total iron concentrations. During the testing period, iron concentrations only in TW 4 has increased with the pumping time while Eh has decreased from positive to negative values. TW 5 showed negative Eh values and high iron concentrations (more than 3.00 mg/l) during the total test period. TW 2 and TW 03 showed low iron concentration (Fig 4.12) while Eh had positive values. The river water also showed positive values of Eh and low iron concentrations (0.28 to 0.54) mg/l. The Eh and iron showed a negative relationship during the pumping period where total iron concentration was high when Eh was low. The pH and Eh values of all sources were plotted on the Eh-pH diagrams for a  $10^{-6}$  molal solution of iron in Figures 2.5-a, b, c, d, and e.

All water samples other than samples from TW 5, occupied the position in the boundary of  $\text{Fe}^{2+}$  and  $\text{Fe}(\text{OH})_3$  in the Eh-pH diagram, whereas TW 5 occupied the  $\text{Fe}^{2+}$  zone (Fig 2.5-e). Samples of TW 4 in the early and latter part of the test occupied the boundary of  $\text{Fe}^{2+}/\text{Fe}(\text{OH})_3$  area and  $\text{Fe}^{2+}$  zone respectively (Fig 2.5- d). Groundwater from the TW 5 and TW 4 fell in the Eh-pH diagram towards the reduced zone while river water and water from TW 2 and TW 3 fell towards the oxidized zone, closer to the  $\text{Fe}^{2+}$  and ferric hydroxide boundary. Water from the oxidizing environments generally shows higher (positive) Eh value than those from the reduced environment (Fetter, 1993). Therefore in our study area the mobility of iron was taking place in the direction from reducing area to the oxidizing area. The groundwater inflow directions to the discharging wells and iron mobility directions were generally the same. In TW 4 iron content showed positive correlation with the pumping rate based on the step test results (Figure:2.6). This was mainly due to rapid groundwater flow in to well at high pumping rates

## WATER QUALITY, SAFETY AND TREATMENT

### Water Quality & Water Safety

where iron does not have enough time to be converted from soluble  $\text{Fe}^{2+}$  form to insoluble  $\text{Fe}^{3+}$  form. When the flow is slow iron can transform in to insoluble  $\text{Fe}^{3+}$  from while water is still on its way to the well within the aquifer. Therefore, most of the insoluble iron precipitates is trapped in the aquifer material, which is common in sand and silt.

According to the hydrogeological environment of the Gannoruwa well field, two zones can be identified using Eh-pH conditions; reducing zone area closer to the river and oxidizing zone area away from the river.

### CONCLUSIONS

The study revealed that the iron content of groundwater from bore hole wells shows high levels close to the river gradually decreasing from the river. Iron mobility takes place in the direction of the groundwater flow from river towards the wells and the concentration increase with increasing flow rate. The distribution and enrichment of the iron in the groundwater are mainly controlled by the Eh-pH conditions. There are two groundwater environments identified in the study area; reducing environment close to the river and oxidizing environment away from the river.

The source of iron is dispersed iron bearing minerals in the aquifer materials and the iron from river water. According to the findings of the study, construction of new bore holes should be done on the oxidizing zone and rate of pumping should be controlled in order to get low iron concentration in pumping wells.

Reference

- 1)Fetter,C.W., 1993. Contaminant Hydrogeology. Macmillan Publishing Company,U.S.A.
- 2)Hem, J.D and Cropper, W.H., 1959., Survey of the ferrous-ferric equilibria and redox potential. U.S. Geological Survey water Supply Paper 1459-A.

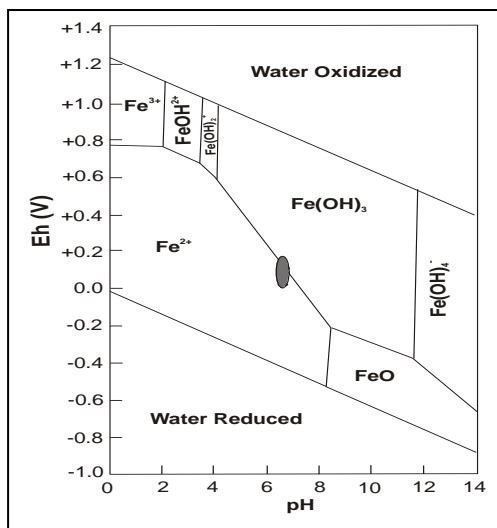

Figure (2.5-b): Stability relations for iron at 25°C, with  $10^{-6}$  moles for River water

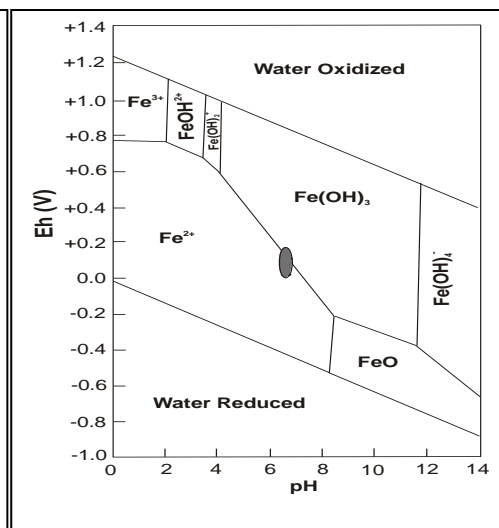
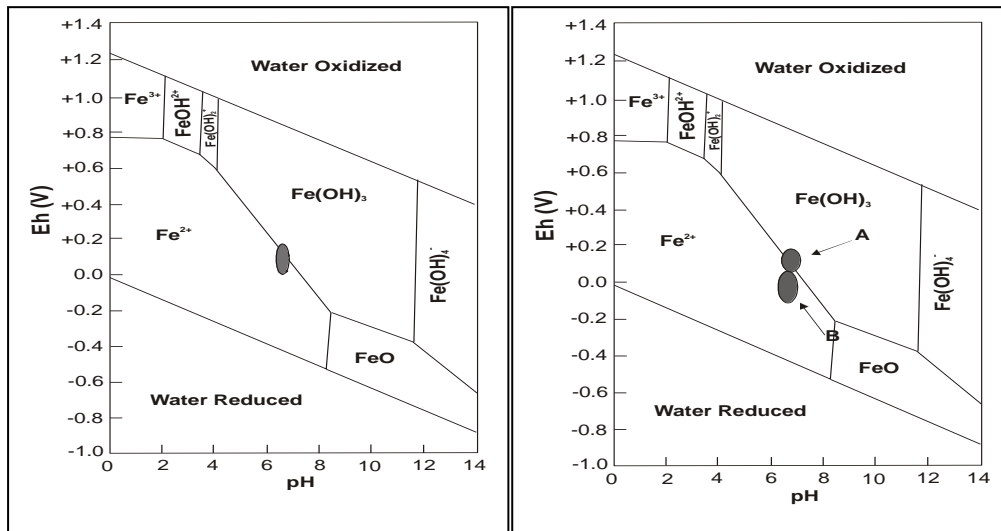

Figure (2.5-a): Stability relations for iron at 25°C, with  $10^{-6}$  moles for TW 2.

WATER QUALITY, SAFETY AND TREATMENT

Water Quality & Water Safety



Figure(2.5 d): Stability relations for iron at 25<sup>o</sup>C, with 10<sup>-6</sup> moles for TW 4; A-early pumping(iron trapped in aquifer),B-late pumping (iron in solution).

Figure (2.5-c): Stability relations for iron at 25<sup>o</sup>C, with 10<sup>-6</sup> moles for TW 3.

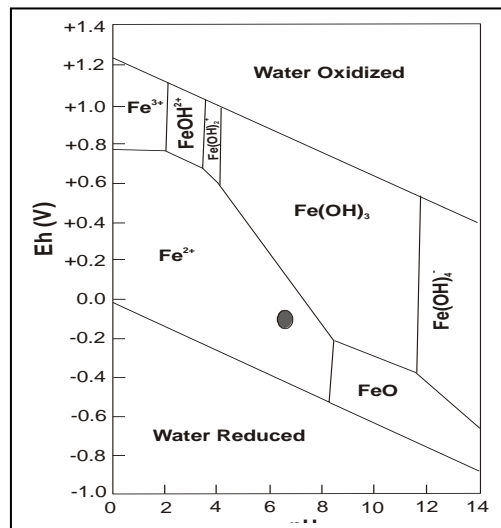

Figure(2.5-e): Stability relations for iron at 25<sup>o</sup>C, with 10<sup>-6</sup> moles for TW 5.

WATER QUALITY, SAFETY AND TREATMENT

Water Quality & Water Safety

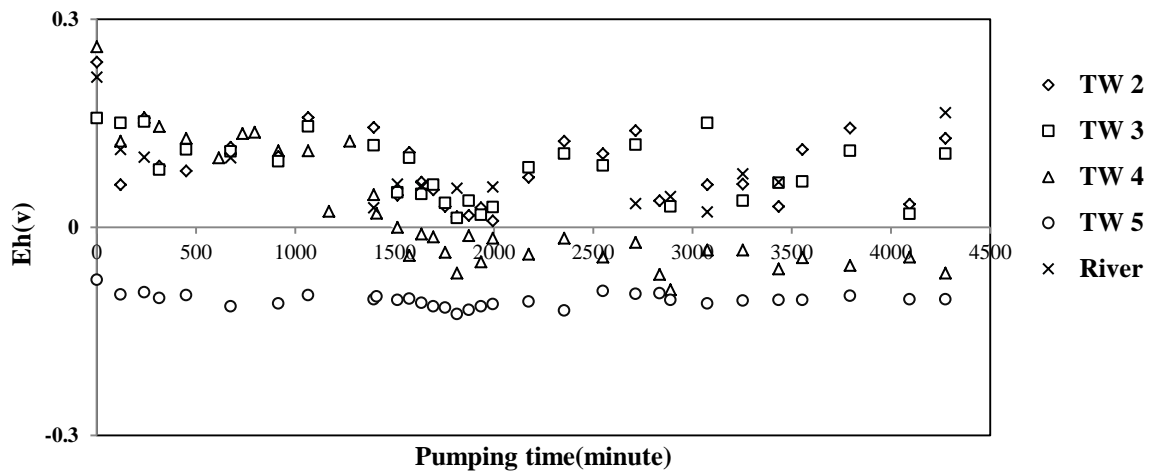

Figure (2.2)-Eh variation during the testing.

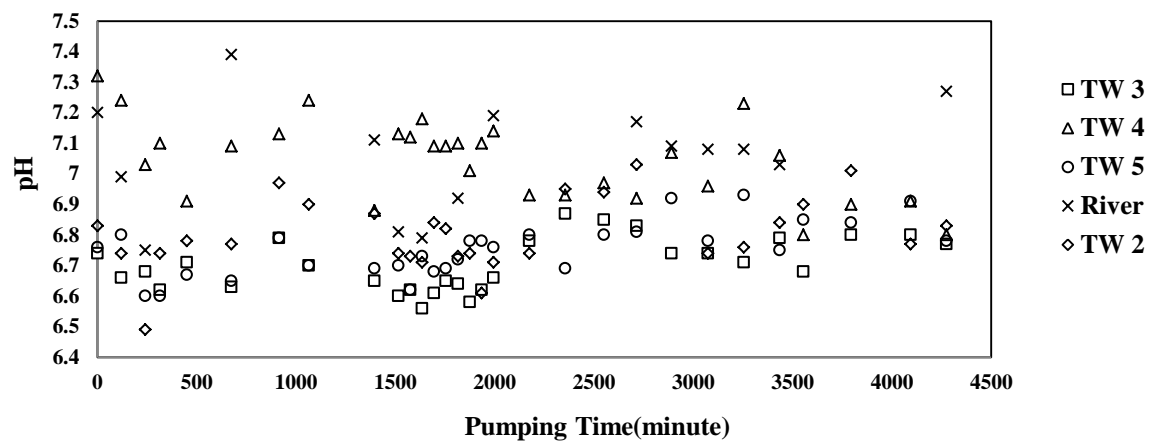

Figure (2.3)-pH variation during the testing.

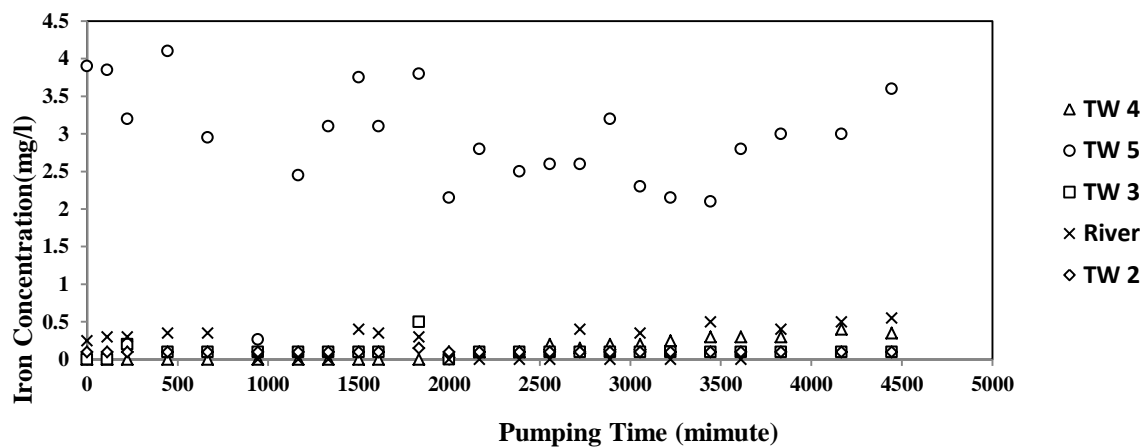

Figure (2.4): Iron variation during the testing.

WATER QUALITY, SAFETY AND TREATMENT

Water Quality & Water Safety



Figure(1.1):Location map of Gannoruwa well field at Peradeniya.

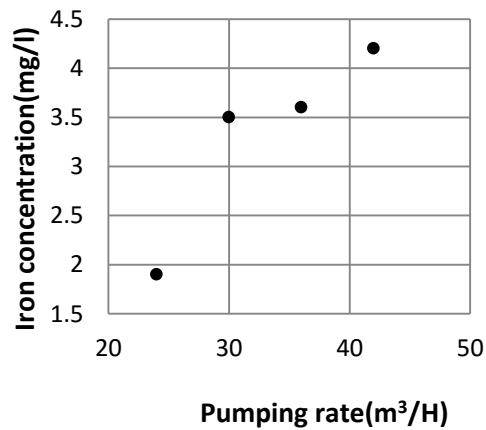

Figure (2.6): iron variation of TW 4 during step test.



WATER QUALITY, SAFETY AND TREATMENT

Water Quality & Water Safety

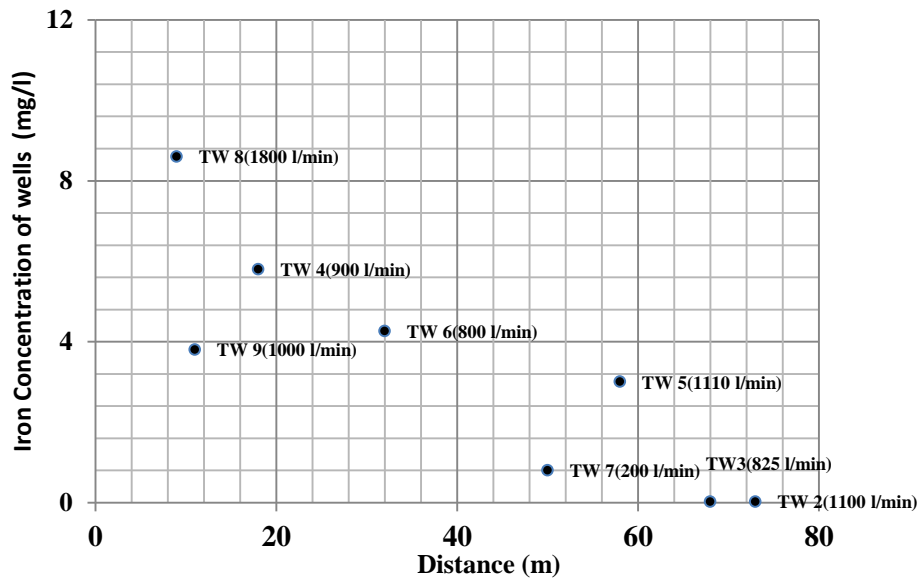

Figure (2.1): iron concentration of the wells under different pumping conditions and distance from the river.

## WATER QUALITY, SAFETY AND TREATMENT

### Water Treatment technologies and business models

#### 3.7.2 Water Treatment technologies and business models

# Traitement et bonne conservation de l'eau à domicile grâce au "Chlore'C". Étude de cas d'une entreprise sociale en Guinée

Type: Article court

**Auteurs :** Pierre-Gilles Duvernay<sup>1</sup>, Aboubacar Camara<sup>2</sup> ;

<sup>1</sup>Chargé de programme Afrique, Fondation Antenna Technologies, Suisse, [pgduvernay@antenna.ch](mailto:pgduvernay@antenna.ch), +41 (0)22 737 12 45

<sup>2</sup>Directeur exécutif Tinkisso-Antenna, Conakry, Guinée, [abscamara@antenna.ch](mailto:abscamara@antenna.ch)

### Abstract/Résumé



Figure 1 : Equipe de production Tinkisso-Antenna

L'entreprise sociale Tinkisso-Antenna a été fondée en 2007 en Guinée dans le but de développer une production locale de flacons de désinfectant chloré et de fournir ainsi à tous les foyers un moyen de potabiliser l'eau à domicile. Le partenariat avec la Fondation suisse Antenna Technologies s'est concrétisé par le don des ressources nécessaires à la création de l'entreprise et d'électrochlorateurs WATA . Cette technologie permet de produire de l'hypochlorite de sodium par électrolyse de l'eau salée.

Tinkisso-Antenna est désormais rentable. Elle est active dans cinq régions et a vendu en 2015 plus de 5,2 millions de flacons de chlore comblant le besoin de 1,4 millions de consommateurs en saison sèche et de 4,7 millions en saison des pluies, période où sévit le choléra.

### Introduction

En Guinée, l'eau est facilement accessible, mais sa qualité est souvent très mauvaise lorsqu'elle arrive au consommateur. Une analyse de la situation a montré que dans 87% des cas, l'eau de boisson était contaminée entre sa source et son lieu de consommation. C'est pourquoi le traitement et la bonne conservation de l'eau à domicile apparaissent comme une stratégie extrêmement prometteuse pour lutter contre le fléau des maladies liées à l'eau.

Cette article présente la réussite de Tinkisso-Antenna, une entreprise sociale guinéenne qui a étendu sa production locale de flacons de désinfectant chloré (*Chlore'C*), et son marketing social et commercial afin d'atteindre les consommateurs les plus pauvres, contribuant ainsi à prévenir les maladies hydriques à l'échelle locale puis nationale depuis 2009. Ce document fournit une feuille de route décrivant chaque étape du processus, de l'introduction à la mise en œuvre à grande échelle de solutions rentables pour rendre l'eau potable. Cette aventure a été riche en expériences et en leçons apprises. En favorisant l'économie locale et en encourageant les jeunes entrepreneurs sociaux à faire de leur projet une entreprise

## WATER QUALITY, SAFETY AND TREATMENT

### Water Treatment technologies and business models

durable, ce modèle d'affaire présente un immense potentiel en Guinée et peut désormais être répliqué dans d'autres pays. Cette réussite commerciale guinéenne est source de fierté pour tous les acteurs impliqués et fournit au pays une solution locale capable de sauver des milliers de vies chaque année. Elle constitue non seulement un moyen d'accéder à l'eau potable, mais elle permet aussi de combattre des maladies telles que le choléra et Ebola.



Figure 2 : Premiers kiosques financés par Antenna

### Description de l'étude de cas

Entre 2005 et 2007, la Guinée a été frappée par plusieurs graves épidémies de choléra. Il a touché 1.516 personnes en 2004, 3.819 en 2005, 3.230 personnes en 2006 et 8.546 cas en 2007 dont 304 décès avec une létalité de 3,6% dans le pays (Bühlmann, Master's Thesis, 2014). Les acteurs des secteurs de l'eau et de l'assainissement optaient alors généralement pour l'importation des flacons de désinfectant chloré, ce qui se traduisait par des temps d'attente prolongés entre les besoins urgents et les interventions. Face à l'impuissance du gouvernement, la population s'est indignée de l'absence de produits de traitement de l'eau.

Tout a commencé à Dabola, une petite ville de 40 000 habitants. En voyant le potentiel de diffusion de la technologie d'Antenna, Aboubacar Camara, un jeune chargé de projet dynamique et motivé au sein d'une ONG, lance un projet pilote en installant des kiosques de promotion de la santé et de vente d'articles sanitaires. Le *Chlore'C*, une solution de chlore actif produite à l'aide du WATA, est rapidement devenu son produit phare. Il était commercialisé en petites bouteilles de 250 ml au prix de 5000 GNF (0,60 €). Comme cette quantité suffisait à désinfecter l'eau de boisson d'une famille de sept personnes pendant un mois, cette méthode de traitement de l'eau était de loin la moins coûteuse à ce moment-là. Toutefois, en tant que très jeune ONG, Tinkisso-Antenna n'avait pas encore l'envergure nécessaire pour attirer les fonds du gouvernement ou d'agences internationales qui lui permettraient de se développer.

### Début de la collaboration avec le gouvernement en vue de produire et distribuer à grande échelle

Le projet pilote de Dabola s'est révélé être un succès, attesté par le net recul du nombre de cas de diarrhée et de choléra dans la zone d'intervention.

En 2007, on a enregistré 58 cas de choléra dont 6 décès dans la région de Dabola, tandis qu'en 2009, aucun cas a été enregistré. Les autorités ont constaté que les cas de maladies diarrhéiques étaient beaucoup moins nombreux à Dabola, un avantage résultant selon elles, directement de la production et de la distribution locales de chlore par Tinkisso-Antenna. La population a également constaté une causalité directe. Ainsi, 95.2% des ménages interrogés ont indiqué d'avoir vu diminuer (52.4%) ou même disparaître (42.8%) les maladies de diarrhées grâce à l'utilisation du *Chlore'C* (Aydogan, Master's Thesis, 2010).

## WATER QUALITY, SAFETY AND TREATMENT

### Water Treatment technologies and business models

Données épidémiologiques de la région de Faranah.	
Source : Docteur Ousmane Yattara / Direction Préfectorale de la Santé de Dabola	
<b>Cas de diarrhées à Dabola chez les enfants de moins de 5 ans.</b>	
<b>Année 2007</b>	3753
<b>Année 2008</b>	3364
<b>Année 2009</b>	1537

La production locale est donc soudainement apparue comme attrayante. Le Bureau de la coordination des Affaires humanitaires (BCAH) des Nations Unies a alors préconisé cette technologie au gouvernement et aux chargés de projet de l'UNICEF. Cela a ouvert la voie à une première expansion: l'UNICEF a acheté 14 dispositifs Maxi-WATA, capables de produire chacun 150 litres de chlore par jour, soit de quoi purifier 600 000 litres d'eau. Cependant, comme l'UNICEF a l'obligation de travailler avec les gouvernements, ces dispositifs ont été remis aux centres régionaux de santé publique auxquels la production et la distribution de chlore ont été confiées. Tinkisso-Antenna s'est vue relégué au rôle de consultant technique. La production était en majeure partie subventionnée par l'UNICEF.

« Une fois qu'il est devenu clair que la plupart des autorités régionales utilisaient les fonds alloués à la production de chlore à d'autres fins et que la production était au point mort presque partout, l'UNICEF a cessé de verser des subventions fin 2009 » (Bühlmann, 2014). Cette première tentative d'expansion s'est ainsi soldée par un échec. Entre temps, Tinkisso-Antenna avait continué à produire et à commercialiser du chlore localement et sans toucher de subventions, ce qui n'a pas échappé à l'attention des autorités sanitaires guinéennes: elles ont ordonné l'affectation des 14 dispositifs Maxi-WATA à un site de production centralisée à Conakry, dont la gestion et la distribution ont été à nouveau exclusivement et définitivement confiées à Tinkisso-Antenna.

### Le risque de se développer trop rapidement et de se disperser

Une fois la production de chlore centralisée à Conakry en 2010, de nouveaux défis ont commencé à émerger. Afin de satisfaire les centres régionaux de santé publique, le ministre responsable, soumis à des pressions politiques, a demandé à Tinkisso-Antenna de fournir du chlore à toutes les régions dont les dispositifs Maxi WATA avaient été dessaisis. Or, dans un pays où les routes sont mauvaises et le transport coûte cher, les chiffres à atteindre étaient bien trop élevés. De plus, le soutien fourni par le gouvernement était insuffisant.

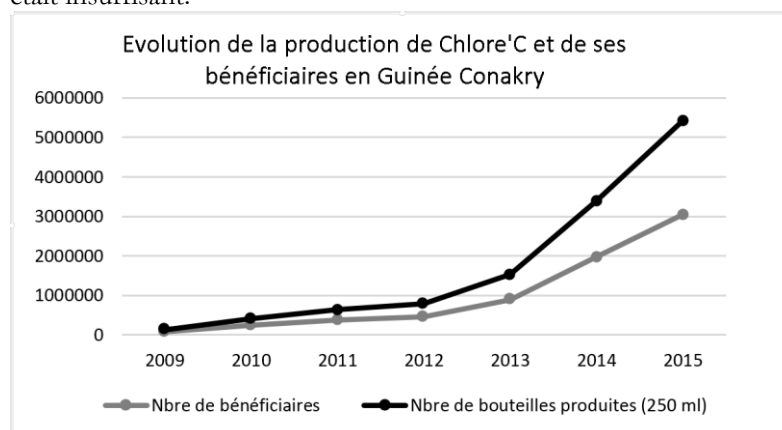

### Une entreprise en plein essor et ses perspectives de croissance

## WATER QUALITY, SAFETY AND TREATMENT

### Water Treatment technologies and business models

Après renégociation des taux de couverture avec les autorités, Tinkisso-Antenna a pu atteindre ses objectifs à son propre rythme en augmentant sa production de 122 % entre 2013 et 2014 et 59% entre 2014 et 2015

Tinkisso-Antenna est désormais rentable. Elle a vendu en 2015 plus de 5,2 millions de flacons de chlore comblant le besoin de 1,4 millions de consommateurs en saison sèche et de 4,7 millions en saison des pluies. Tinkisso-Antenna emploie directement 129 personnes dont 27 femmes, ce qui représente un de ses objectifs sociaux. De plus, des revenus sont générés pour 40 vendeuses de rue et plusieurs centaines d'agents communautaires détachés des centres de santé. En 2014, elle a atteint son seuil de rentabilité avec un chiffre d'affaires de 1,6 million d'euros. Grâce à la créativité dont elle fait preuve dans ses campagnes de marketing social, l'entreprise est parvenue avec succès à transformer durablement les habitudes en matière d'eau et d'hygiène. De plus, elle teste en permanence de nouveaux canaux de distribution afin de desservir toutes les communautés dans les zones urbaines et rurales. En aidant le gouvernement et les agences de l'ONU à lutter contre les maladies hydriques à l'aide d'un produit local guinéen, Tinkisso-Antenna est devenue une entreprise de référence.

### Résultats principaux :

Données épidémiologiques de la région de Faranah.					
Source validée le 30.08.16 : Docteur Péné Bilivogui / Directeur National de l'Hygiène Publique de Guinée					
Année 2010					
Villes	Schistosomiase intestinale	Diarrhée sanglante	Diarrhée non sanglante	Fièvre typhoïde	Helminthiases
Faranah	1072	1542	6906	575	11986
Dabola	180	2243	5217	1625	10924
Dinguiraye	182	608	4004	652	10882
Kissidougou	3263	3564	17553	4931	19165
Année 2011					
Villes	Shistosomiase intestinale	Diarrhée sanglante	Diarrhée non sanglante	Fièvre typhoïde	Helminthiases
Faranah	882	488	4288	625	8261
Dabola	209	932	3864	933	12339
Dinguiraye	423	549	4427	1077	12122
Kissidougou	476	857	12584	3409	16476
Année 2012					
Villes	Shistosomiase intestinale	Diarrhée sanglante	Diarrhée non sanglante	Fièvre typhoïde	Helminthiases
Faranah	398	374	3086	41	5707
Dabola	211	662	2976	528	8731
Dinguiraye	18	252	2003	228	5987
Kissidougou	141	671	10153	2901	12078

Les perspectives de croissance de Tinkisso-Antenna sont également intéressantes : l'entreprise a élargi sa gamme de produits nécessaires pour lutter entre autre contre l'épidémie d'Ebola en offrant notamment des bouteilles de chlore plus concentré ainsi que d'autres articles d'hygiène et de désinfection.

PSI (Population Services International) en Guinée diffusait jusqu'à récemment des flacons de chlore fabriqués au Libéria avec des intrants d'outre-mer et largement subventionnés. Cette structure les fait désormais produire par Tinkisso-Antenna sous sa propre marque afin d'assurer une solution locale et pérenne.

Il reste par ailleurs de nombreuses régions où Tinkisso-Antenna doit encore commercialiser ses produits pour couvrir l'ensemble du territoire national. Cette expansion se fera par étapes. Cependant, des défis sont encore présents : La nécessité d'agrandir le site de production, l'arrivée possible d'un concurrent sans volet social ainsi qu'une taxation importante. En s'impliquant dans la défense du droit humain fondamental d'accéder à l'eau potable, Tinkisso-Antenna entend bien faire partie de la solution et offrir de l'eau potable à tous les Guinéens.

## WATER QUALITY, SAFETY AND TREATMENT

### Water Treatment technologies and business models

#### Leçons fondamentales tirées de cette expérience

**Rôles complémentaires du gouvernement et du secteur privé pour accroître la production et la distribution:** Pour développer le commerce d'eau potable à grande échelle, il est nécessaire d'opter pour un modèle hybride permettant la collaboration d'acteurs publics et privés. Alors que le secteur public a la capacité de créer un marché pour l'eau potable en lançant d'importantes campagnes éducatives sur la santé et l'hygiène, le secteur privé peut quant à lui fournir les moyens de purifier l'eau.

**Assurer la viabilité économique sur les lieux et un soutien à long terme aux entreprises sociales:** La viabilité économique comporte trois éléments fondamentaux: une technologie efficace, mais simple, un modèle commercial clair et une forte présence locale. Pour qu'une entreprise sociale démarre sur une base solide, elle doit pouvoir bénéficier assez tôt de soutien lui permettant de renforcer ses capacités et ses ressources.

**Conditions requises pour fournir de l'eau potable à grande échelle ailleurs dans le monde:** L'approche des modèles d'entreprise peut être reproduite dans n'importe quel pays du moment qu'il réunit certaines conditions : **a)** l'eau doit être une denrée facilement accessible, **b)** le financement par des donateurs est possible (partenariat public-privé) afin de lancer des campagnes de sensibilisation à vaste portée sur l'eau potable et **c)** la demande doit être entretenue grâce à un marketing social puissant.

La réplique adaptée au Burkina Faso a déjà commencé. Une représentation locale d'Antenna et un partenaire technique sont opérationnels. Un état des lieux du TED au niveau des Ministères concernés a été documenté. Les acteurs du WASH, mené par Antenna se sont fédérés autour de la réalisation d'un document de plaidoyer afin d'intégrer le TED dans le Programme National d'Approvisionnement en Eau Potable et d'Assainissement (PN-AEPA) post 2015. Parallèlement, des programmes dans les écoles sont mis en place par le Ministère de l'Education (MENA) afin que les élèves deviennent promoteurs du TED dans leur foyers et créent le futur marché pour les flacons de chlore. Les conclusions de l'étude de marché sont positive et une pépinière d'entreprise locale mandatée par Antenna va sélectionner un entrepreneur, l'accompagner pour la réalisation de son business plan et l'assister dans sa recherche d'investisseurs. Une fabrique de flacons sera créée. Si le plaidoyer porte ses fruits, le marketing social du TED sera pris en charge par les ONGs sur mandat du gouvernement burkinabé ce qui permettra à l'entreprise de concentrer ses ressources sur le marketing commercial en vue d'une couverture nationale. Les risques sont liés aux taxes importantes dont l'exemption jusqu'au seuil de rentabilité devra être négociée avec le Ministère des finances avec l'appui du « Programme présidentiel d'urgence » créé en 2016.

En collaboration avec le Programme global Initiatives Eau de la DDC, la fondation Antenna Technologies a commencé à recréer de tels projets en Asie avec l'objectif de prouver que ces exemples peuvent être reproduits et diversifiés.

#### Conclusions

- Il reste encore malgré tout sur le terrain des tenants d'une position dogmatique négative vis-à-vis du partenariat public-privé. Par exemple, une agence onusienne a refusé de financer une campagne de marketing social prévue dans notre zone d'intervention car elle aurait pu faciliter la vente du Chlore C, considérée comme une activité commerciale pure. La notion d'entreprise sociale n'existe actuellement pas en Guinée.
- L'obtention prochaine de crédits carbone permettra de valider la dimension écologique du projet (réduction de l'utilisation de bois de chauffage pour bouillir l'eau)

## WATER QUALITY, SAFETY AND TREATMENT

### Water Treatment technologies and business models

- Plusieurs gouvernements de la sous-région ont manifestés leur intérêt pour des prestations de conseils en vue d'une réplique de Tinkisso-Antenna dans leurs pays respectifs.
- La Fondation Antenna Technologies et son partenaire Tinkisso-Antenna sont prêts à répliquer ce modèle d'affaire dans d'autres pays.



Figure 5 : Matériel promotionnel pour le Chlore'C

### Recommandations

- Sur le plan opérationnel, il est important de développer des partenariats avec les acteurs locaux notamment les ONGs, les distributeurs des produits, les médias, et les structures de santé afin de faciliter la couverture de l'ensemble des zones d'intervention et pour sensibiliser les ménages, au travers de campagnes de marketing social de masse.
- L'identification de grossistes et points de vente au niveau de sa zone d'intervention et hors zone facilitera l'accès du produit aux consommateurs intermédiaires et finaux.
- Une participation régulière aux réunions de clusters WASH permet de conjuguer les efforts en cas d'épidémies de choléra et Ebola, de former les acteurs sur l'utilisation de la solution chlorée, et de participer au débat sur la relance du système de santé du pays.
- La dépendance vis-à-vis de l'unique fabricant de flacons vide en Guinée est un handicap qu'il convient d'éliminer par l'installation d'une machine (souffleuse de flacons) sur le site de Tinkisso-Antenna.

### Mentions

Un tel succès n'aurait toutefois pas été possible sans une collaboration solide et durable avec la fondation Antenna Technologies, qui a joué un rôle essentiel dans le renforcement de ses capacités organisationnelles, techniques et commerciales et lors de la prise de décisions stratégiques. La fondation a accordé un prêt d'exploitation d'un montant de 135'000 euros à Tinkisso-Antenna. Les bénéfices générés par Tinkisso-Antenna lui permettent maintenant de rembourser cette somme. Un don d'une valeur totale de 500'000 euros sur six ans a permis de développer les connaissances et le savoir-faire au niveau des outils et des appareils de production, ainsi que du processus de qualité et du marketing social. Ce genre d'engagement à long terme est essentiel pour mettre en place un modèle d'entreprise durable, un exemple qui peut désormais être reproduit dans d'autres pays.

### Références

Alain Bühlmann « Marketing safe water to the base of the pyramid – lessons for scaling up a social enterprise in Guinea », Master's Thesis, 2014, Université de Saint-Gall, disponible à l'adresse URL <http://www.poverty.ch/safe-water-bop.html>

Oezge Aydogan « Opportunities and Limits of Business Approaches for Poverty Alleviation », Master's Thesis, 2010, Université de Saint-Gall, disponible à l'adresse URL <http://www.poverty.ch/safe-water-bop/safe-water-guinea.html>

Fondation Antenna Technologies, 2016, disponible à l'adresse URL <http://www.antenna.ch/recherche/eau-potable/wata-description>

Fondation Antenna Technologies, 2016, disponible à l'adresse URL <http://www.antenna.ch/recherche/eau-potable/guinee>

WATER QUALITY, SAFETY AND TREATMENT

Water Treatment technologies and business models

# Access is not enough: ensuring water stays safe in the home with Dispensers for Safe Water

Type: Short Paper

**Authors** *Andy Narracott, Deputy Director, Global Safe Water, Evidence Action, Kenya,*  
[andy.narracott@evidenceaction.org](mailto:andy.narracott@evidenceaction.org) +254 706350556

**Abstract/Summary**

There has been huge progress made in improving access to safe water in recent years. However, research shows that water improvements at the source do not fully translate into health gains, as contamination occurs in the home<sup>1</sup>. Yet, a focus on market-based household water treatment solutions has failed to achieve high levels of adoption for very poor communities<sup>2</sup>. As a result, many very rural and very poor communities are still underserved in many parts of the world. We believe safe water is really an issue of equity. We have a different approach. Chlorine is a proven, low-cost water treatment solution that keeps water safe<sup>3</sup>. Dispensers for Safe Water operates a network of 27,000 chlorine dispensers across 5,500 square miles, serving 4.7 million people in three countries, in partnership with local and national governments, at under \$1 per person / year at scale. Because of economies of scale in distribution costs and the high levels of usage observed over time, Dispensers for Safe Water have the potential to be a cost-effective means of sustaining high usage of chlorination in the home and ultimately preventing diarrhea.

**Introduction**

Chlorine is a low cost, effective water treatment solution that is routinely applied to urban water supplies to keep water safe up to the point of consumption. Studies show that clean water was responsible for about half the observed decline in mortality and nearly two-thirds of the reduction in child mortality in US cities over time<sup>4</sup>. Due to the dispersed nature of rural water sources, pre-chlorination at the source has not been possible. This paper illustrates how Dispensers for Safe Water achieves a high level of household chlorine usage at scale, currently at 60% program wide and sustained over at least five years. Having refined the model in Kenya and replicated and scaled the program in Uganda and Malawi in partnership with the national government, we currently have over 27,000 dispensers installed across the three countries that provide access to safe water to 4.7 million people for under \$1 per person per year.

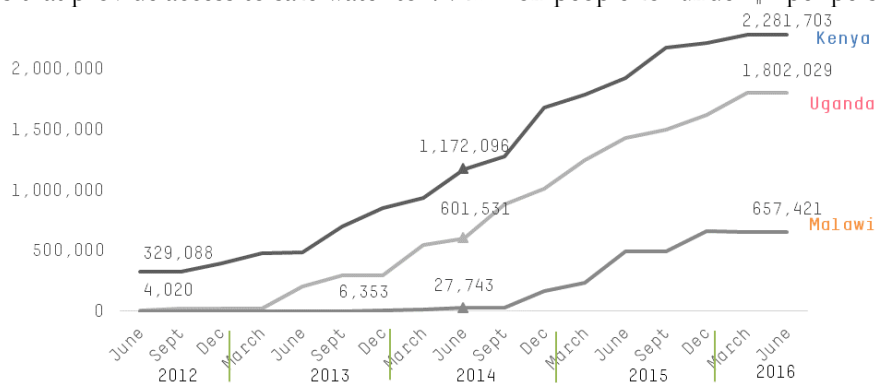

Figure 1: Access to Dispensers for Safe Water, which refers to the number of people served by Dispensers for Safe Water across the three countries of our operation. We collect and verify data on the number of households that are using a given waterpoint. We then estimate the number of people per household based on monthly surveys of randomly selected households in that catchment area.<sup>5</sup>



## WATER QUALITY, SAFETY AND TREATMENT

### Water Treatment technologies and business models

#### Description of the Case Study – Approach or technology

Dispensers for Safe Water places chlorine dispensers in the immediate vicinity of wells and other water sources. The dispenser is a blow-molded tank fitted with a 3ml ball valve. One turn of the valve releases a 3 ml dose of sodium hypochlorite, sufficient to treat 20 L of non-turbid water (<100 NTUs) and protect against recontamination for at least 24 hours<sup>6</sup>. We fill the tank with sodium hypochlorite (liquid chlorine) solution and install at the water source in a protective casing. To use the dispenser, people go to their water source, place their bucket or jerrican under the dispenser, turn the valve to dispense the correct amount of chlorine, and then fill the bucket as they normally would with water from the source. The chlorine disinfects the water as they are walking home, and by the time they arrive, much of the chlorine smell has dissipated and they are left with clean, safe water that stays safe for 2-3 days.

#### Chlorine dispenser hardware



#### Community education & promotion



#### On-going chlorine service delivery



We focus on sustainable service delivery, as opposed to a one-time hardware installation. Thus, the chlorine dispenser system extends beyond the dispenser hardware to include community education and a regular supply of chlorine refills. Evidence Action educates the community about the dangers of contaminated water and how to use the dispenser to treat their water. A community member is elected to be the dispenser ‘promoter’, who encourages use of the dispenser, reports any problems, and refills the dispenser with chlorine.

#### Main results and lessons learnt

Dispensers for Safe Water follows the approach of Evidence Action, which looks for evidence of a solution that works, and then turn it into a scalable solution to reach millions of people. While there are a lot of water products in the market, Dispensers for Safe Water could be the most effective solution to lack of safe water in rural areas. There are several reasons for this.

- a. **Chlorine dispensers are a rigorously tested and proven effective solution:** Randomized controlled trials have documented that point-of-use chlorination programs are an effective means of improving water quality and can reduce reported child diarrhea morbidity by 29%<sup>7</sup>. Another

## WATER QUALITY, SAFETY AND TREATMENT

### Water Treatment technologies and business models

study in Kenya<sup>8</sup> found that only 8% of households using socially-marketed bottles sold in shops reported chlorinating their water in the past week. Dispensers for Safe water achieves a sustained 60%<sup>9</sup> which is 6 times higher, and 2) use is being sustained over time<sup>10</sup>.

- b. **Salient and focused on behavioral change:** Chlorine dispensers use evidence from behavioral economics to overcome the barriers to adoption of water treatment. The location of the dispenser directly at the water source makes drinking water treatment convenient, salient, and public. We also remove user fees, which has been shown to reduce access to preventative health products for the poor<sup>11</sup>.
- **Convenient:** Using the dispenser is convenient because the dispenser valve delivers an accurate dose of chlorine to treat a standard 20 L jerrican. The required agitation and wait time for chlorine treated water are also at least partially accomplished during the walk home from the source. Accurate dosing, perfected by several years of product iteration, reduces the likelihood that treated water will have a chemical after-taste.
  - **Salient:** The dispenser hardware itself provides a frequent visual reminder to individuals to treat their water when it is most salient – at water collection. Other household treatment models are exposed to the risk that users will forget to treat water later. This visual reminder combined with chlorination encourages habit formation.
  - **Public:** The public nature of the dispenser system maximizes the potential for social learning, habit formation, and peer effects; this is similar to the way that hand washing in restrooms goes up when people are watched<sup>12, 155</sup>.
  - **Free to customers:** In part because the links between clean water and some diseases are not intuitive, willingness to pay for safe water is low, as documented in “The Price is Wrong” by J-PAL at MIT<sup>13</sup>. Charging even a small positive user fee screens out many potential users from realizing the benefits of chlorine. When the price barrier is removed, adoption increases 10-fold.

We have sustained adoption at 60%+ even while scaling the program to millions of people. This compares to take-up rates of no more than 6% for packaged chlorine intended for use in the home and socially marketed in similar contexts<sup>14</sup>. As Figure 2 reveals, adoption of chlorine in Uganda dipped below 20% in Jan 2015, as a result of rumours spreading of the negative effects of chlorine and issues with supply chain of chlorine. Since adoption is measured each month to allow adaptive programing, we were able to address the issues immediately and trigger a turnaround in consumer behaviour.

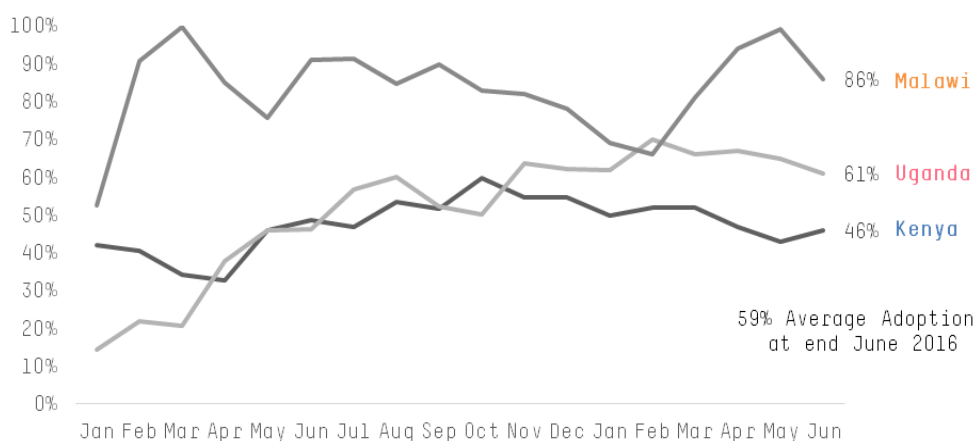

Figure 2: *percentage of randomly sampled households that tested positive for residual chlorine ('Total Chlorine Residual') in their drinking water during an unannounced household visit<sup>15</sup>*

<sup>155</sup> Amy J. Pickering, Annalise G. Blum, Robert F. Breiman, Pavani K. Ram, Jennifer Davis Video Surveillance Captures Student Hand Hygiene Behavior, Reactivity to Observation, and Peer Influence in Kenyan Primary Schools. Published: March 27, 2014 <http://dx.doi.org/10.1371/journal.pone.0092571>

## WATER QUALITY, SAFETY AND TREATMENT

### Water Treatment technologies and business models

- c. **Sophisticated maintenance and supply chain:** In order to achieve high usage rates, dispensers need to be continually functional, never run out of chlorine and community promoters need to be supported. Evidence Action provides on-going servicing of dispensers so that communities have access to chlorine indefinitely. We have developed a strong manufacturing system with stringent quality control that consistently produces hardware and chlorine locally that adheres to East African Community manufacturing standards. Evidence Action and our partners operate a supply chain that fills the crucial “last mile” gap in service delivery, bringing chlorine refills to the local promoter at each dispenser every 2-3 months. Our distribution model utilizes motorbikes to deliver chlorine refills to remote rural areas according to usage rates. The last mile distribution of chlorine is undertaken by community health workers and volunteer dispenser promoters, who are responsible for refilling the dispensers with chlorine.
- Dedicated M&E field officers regularly monitor our service delivery operations and adoption rates, which we use to adjust our operations as necessary, hold staff accountable for service delivery targets, and track our impact.
  - With regular maintenance and replacement of parts if they breakdown, the dispenser hardware can be maintained indefinitely. The expected durability of the primary dispenser components assuming average field conditions is five years; we allocate replacements and associated budgets according to this estimate.
  - Local promoters are encouraged to call Evidence Action at any time to report dispenser related problems.
- d. **Cost Effective:** According to a 2007 academic study<sup>16</sup>, chlorine is more cost-effective than other solutions such as solar disinfection, flocculation, and ceramic filters. The combination of lower cost and higher effectiveness renders household-based chlorination the most cost effective of water quality interventions to prevent diarrhea, and the study suggests a cost effectiveness ratio in Africa of US\$53 per disability-adjusted life year (DALY) averted, compared to US\$123 for conventional source-based interventions.
- Chlorination in the home is less than one-sixth of the cost of treating water with ceramic filters at the household level according to a meta-analysis of water quality interventions for preventing diarrheal disease<sup>17</sup>. It is the most cost-effective strategy rural household water treatment in developing countries according to the WHO<sup>18</sup>.
  - Evidence Action’s dispensers get chlorine into more homes at a fraction of achieving the same level of coverage via treatment in the home, in part because we operate in bulk. Additionally, dispensers are rated as the most cost-effective intervention to reduce diarrhea by leading researchers at the Abdul Latif Jameel Poverty Action Lab (J-PAL) at Massachusetts Institute of Technology (MIT)<sup>19</sup>.
- e. **Equity & Social Returns:** We believe safe water is really an issue of equity. We are reaching the people left behind by current market-based approaches i.e. the cohort of people who are very rural and very poor in Sub-Saharan Africa. We are also targeting health impacts with our models of averted diarrhea and averted DALYs. DALY is an actuarial term that tries to calculate the number of years lost due to ill-health, disability or early death — it’s used as a way to compare the overall health and life expectancy in different countries, especially developing countries versus more developed countries.
- We know that chlorine kills bacteria, and we know from various evidence that bacteria reduction reduces diarrhea. In fact, water systems the world over routinely chlorinate water. We can measure self-reported diarrhea, and while we cannot measure actual diarrhea reductions due to high costs and complexity, our detailed impact models estimate we have averted 795 deaths, and each year of a dispenser’s operations means 0.57 years of healthy life is not lost. Our dispensers have also resulted in \$ 20 million of income gains to rural households in East Africa.

## WATER QUALITY, SAFETY AND TREATMENT

### Water Treatment technologies and business models

- Our impact model uses baseline and project state surveys from our program and secondary source information from academic studies using the most generally conservative and the statistic most appropriate for the situation.
- With dispensers, we offer households the opportunity to leapfrog to a cleaner technology than boiling for drinking safe water<sup>20</sup>.

While dispenser access is free to users, we only rely on loans or grant funding to cover the 2-3 year period until revenues from carbon credits are received. Dispensers, like other safe water and energy projects, are allowed to generate carbon credits by providing a “clean development pathway”. This is because chlorine dispensers avert carbon emissions – people do not need to boil water to disinfect it. Despite declining carbon prices, chlorine dispensers are cost-effective enough to survive in a low-price environment. We use the revenue earned from these carbon sales to reinvest in the program and keep it free to users. This financing model is effectively a payment for results model, because credits are only issued when water is safe and actually consumed, which could satisfy value for money criteria for many bilateral funders.

Investment costs are upwards of \$50,000 for a 50 dispenser trial with technical assistance and support from Evidence Action. As Dispensers for Safe Water scales, unit costs drop to below \$1 per per person per year at scale. At current scale, it costs Evidence Action on average \$170 per year to service a dispenser. The dispenser itself is manufactured and assembled in Nairobi, with the high-precision ball valve sourced from suppliers in the US. The hardware cost of a complete unit is around \$50 when procuring directly from suppliers in bulk.

In Malawi, we have been implementing cost-sharing arrangements with the government which has worked well. The Ministry of Health’s community health workers conduct the community education and last mile chlorine delivery. The government committed to financially support the procurement of chlorine, but has so far yet to happen. In Kenya, we received county government commitments to procure the liquid chlorine, but again have yet to be fulfilled. These partnerships have the potential to lower operational costs and achieve greater buy-in at a national level.

### Conclusions and Recommendations

Because of economies of scale in distribution costs and the high levels of usage observed over time, Dispensers for Safe Water have the potential to be a cost-effective means of sustaining high usage of chlorination in the home and ultimately preventing diarrhea. Dispensers for Safe Water is already being scaled up, reaching 4.7 million people in East Africa with sustained take-up rates of over 60% and projected costs of less than \$1 per person per year at scale.

The program started in Kenya and moved to Uganda, then Malawi, with no change to the basic delivery model, signalling that this solution is not context specific and can be scaled elsewhere. Evidence Action has codified the approach into five easy steps for installation and ongoing maintenance and is well positioned to provide technical assistance and support to other program implementers, local businesses and governments.

### References

- Kremer, M.; Leino, J.; Miguel, E.; Zwane, A. P., Spring Cleaning: Rural Water Impacts, Valuation, and Property Rights Institutions\*. *The Quarterly Journal of Economics* **2011**, *126*, (1), 145-205.
- <sup>2</sup> Arnold, B. F.; Colford, J. M., Treating water with chlorine at point-of-use to improve water quality and reduce child diarrhea in developing countries: A systematic review and meta-analysis. *The American Journal of Tropical Medicine and Hygiene* 2007, *76*, (2), 354-364.
- <sup>3</sup> WHO Guidelines for Drinking Water Quality (see Chapter 7, especially).
- <sup>4</sup> Cutler, D. M. & Miller, G. "The Role of Public Health Improvements in Health Advances: The Twentieth-Century United States." *Demography* 42.1 (2005): 1-22. Project MUSE. <<https://muse.jhu.edu/>>
- <sup>5</sup> Evidence Action online dashboard: <http://dispenserdata.evidenceaction.org/#/?k=7m5gfh>
- <sup>6</sup> Lantagne, D. S., Sodium hypochlorite dosage for household and emergency water treatment. *American Water Works Association. Journal* **2008**, *100*, (8), 106-119,14

## WATER QUALITY, SAFETY AND TREATMENT

### Water Treatment technologies and business models

- <sup>7</sup> Arnold, B. F.; Colford, J. M., Treating water with chlorine at point-of-use to improve water quality and reduce child diarrhea in developing countries: A systematic review and meta-analysis. *The American Journal of Tropical Medicine and Hygiene* **2007**, *76*, (2), 354-364
- <sup>8</sup> Kremer, M.; Leino, J.; Miguel, E.; Zwane, A. P., Spring Cleaning: Rural Water Impacts, Valuation, and Property Rights Institutions\*. *The Quarterly Journal of Economics* **2011**, *126*, (1), 145-205.
- <sup>9</sup> Evidence Action online dashboard: [http://dispenserdata.evidenceaction.org/#/?\\_k=7m5gfh](http://dispenserdata.evidenceaction.org/#/?_k=7m5gfh)
- <sup>0</sup> Kremer M, Mullainathan S, Zwane A, Miguel E, Null C (2008). Social Engineering: Evidence from a Suite of Take-up Experiments in Kenya.
- <sup>1</sup> Abdul Latif Jameel Poverty Action Lab (2011), The Price is Wrong, JPAL Bulletin.  
Amy J. Pickering , Annalise G. Blum, Robert F. Breiman, Pavani K. Ram, Jennifer Davis Video Surveillance Captures Student Hand Hygiene Behavior, Reactivity to Observation, and Peer Influence in Kenyan Primary Schools. Published: March 27, 2014 <http://dx.doi.org/10.1371/journal.pone.0092571>
- <sup>2</sup> Abdul Latif Jameel Poverty Action Lab (2011), The Price is Wrong, JPAL Bulletin.
- <sup>3</sup> Kremer, M.; Leino, J.; Miguel, E.; Zwane, A. P., Spring Cleaning: Rural Water Impacts, Valuation, and Property Rights Institutions\*. *The Quarterly Journal of Economics* **2011**, *126*, (1), 145-205
- <sup>4</sup> Evidence Action online dashboard: [http://dispenserdata.evidenceaction.org/#/?\\_k=7m5gfh](http://dispenserdata.evidenceaction.org/#/?_k=7m5gfh)
- <sup>5</sup> Clasen T, Haller L, Walker D, Bartram J, Cairncross S (2007). Cost-effectiveness analysis of water quality interventions for preventing diarrhoeal disease in developing countries. *J. Water & Health* *5*(4):599-608.
- <sup>6</sup> Clasen, Schmidt, Rabie, Roberts, Cairncross (2007). “Interventions to Improve Water Quality for Preventing Diarrhea: Systematic Review and Meta-Analysis”
- <sup>7</sup> WHO Guidelines for Drinking Water Quality (see Chapter 7, especially).
- <sup>8</sup> <http://www.povertyactionlab.org/policy-lessons/health/child-diarrhea>
- <sup>9</sup> CDM Executive Board (2012) Low greenhouse gas emitting safe drinking water production systems. AMS.III-AV (ver 03).

## WATER QUALITY, SAFETY AND TREATMENT

### Water Treatment technologies and business models

# Funding chlorine dispensers for community water supply through carbon finance

Type: Short Paper

## Authors

Lars Osterwalder, Senior Consultant, South Pole Group, Ethiopia  
[losterwalder@thesouthpolegroup.com](mailto:losterwalder@thesouthpolegroup.com), +251 912 79 58 17

Andy Narracott, Evidence Action, Kenya

## Abstract/Summary

This paper illustrates how carbon finance can be used to finance water treatment projects based on Evidence Action's chlorine dispenser program in Eastern Uganda. It was found that boiling 5,295 L of water leads to one ton of carbon dioxide emissions. The case project explored in this paper replaces boiling with a low-emission technology (chlorine dispensers), which means that carbon credits can be claimed for the volume of safe water provided to end users (converted into tons of avoided/averted carbon emissions). Once issued, the carbon credits need to be sold. The revenue generated from the carbon credits is sufficient enough to cover costs that traditional donors and governments are often not willing to cover, e.g. operation and maintenance costs. Carbon credits allow an innovative results-based financing model for sustainably providing safe water at no cost to the rural poor in Uganda.

## Introduction

Over the past few years, carbon finance has been discussed as a funding opportunity for safe water projects as a new form of subsidy that can contribute significantly to reducing the financial burden for the base of the pyramid (Heierli, 2014). However, some stakeholders specify that safe water products should not be given away in the form of dumping them on people who do not want them. Attention should also be given to the setup of a sustainable distribution channel for the replacements and spare parts of the envisaged products (Heierli, 2014). In addition, carbon financed programs have been criticised for not actually reducing carbon emissions - especially when referring to the controversial “suppressed demand” assumption (Hodge, 2014).

Evidence Action, a non-profit organization based in the US, has installed more than 5,500 chlorine dispensers in Eastern Uganda between 2013 and 2016. Evidence Action works with South Pole Group, a carbon project developer and leading sustainability solutions provider headquartered in Switzerland, to generate carbon credits from their safe water program. This paper aims to illustrate, on the basis of a concrete example, how carbon finance can be used as a results-based funding mechanism to provide safe drinking water to poor rural communities. The paper provides insights on how the carbon registration process works, what data needs to be collected and what financial return can be expected.

## Description of the Case Study – Approach or technology

Treating water with chlorine at the source provides an effective, low-cost and safe approach to improving water quality and reducing the impact of child diarrhoea in Uganda. Chlorine kills 99.99% of harmful bacteria, keeps water free from recontamination for up to 72 hours, and reduces the incidence of diarrhoea by approximately 40% (Evidence Action, 2013). The chlorine dispenser system consists of the dispenser hardware, community education, and a regular supply of chlorine. To use the dispenser, community members go to their water source, place their bucket or jerrican under the dispenser, turn the valve to dispense the correct amount of chlorine, and then fill the bucket as they normally would with

## WATER QUALITY, SAFETY AND TREATMENT

### Water Treatment technologies and business models

water from the source. Evidence Action educates the community about the dangers of contaminated water and how to use the dispenser to treat their water. A community member is elected to be the dispenser “promoter”, who encourages the use of the dispenser, reports any problems, and refills the dispenser with chlorine when needed. Evidence Action provides on-going servicing of the dispensers in a way that ensures that communities have access to safe water over the long-term. Chlorine dispensers are an innovative, low-cost approach proven to increase rates of treated household water and provide residual protection against recontamination.

The chlorine dispenser program in Uganda has been included under South Pole Group’s ‘International Water Purification Programme’ – a Programme of Activities (PoA) registered under the United Nations’ Clean Development Mechanism (CDM) and the Gold Standard. The CDM, one of the market mechanisms defined in the Kyoto Protocol, provides the framework for emissions reduction projects that generate carbon credits for international emission trading schemes; and the Gold Standard was initiated by a group of non-government organizations to certify carbon projects that not only reduce carbon emissions but also demonstrably contribute to sustainable development. In this case, carbon reductions are achieved by replacing boiling of drinking water by an alternative low-carbon technology (i.e. chlorine dispenser). In Uganda 70.6% of the households in urban and 37.7% in rural areas boil their drinking water in order to make it safe for consumption (DHS Uganda, 2011). The applied CDM methodology (CDM, 2012) includes the notion of “suppressed demand”, i.e. households that currently do not boil their water but would do so if they had more resources are also eligible for carbon credit generation. In Uganda only 8% of households in the poorest wealth quintile report to boil their water compared to 77% in the richest quintile (DHS Uganda, 2011); hence there is good evidence that support the assumption “suppressed demand”, as indeed a major increase of fuel consumption for water treatment has to be expected as a result of economic development.

### Main results and lessons learnt

In order to register chlorine dispensers under the CDM, a baseline survey was conducted to establish a conversion factor from meter cubes of safe drinking water to tons of reduced carbon emissions. In case of the first component of the carbon project (including 1,150 chlorine dispensers in Kibuku, Budaka and Manafwa districts), it was found that the vast majority of interviewed households use firewood and traditional three stone fires for boiling water (220 out of 241). Based on the stoves’ thermal efficiency (e.g. a default value of 10% for three stone fires provided by the CDM methodology), the specific energy consumption of boiling water (as per the calculation provided in the CDM methodology and based on heating the water from 20°C to 100°C and boiling for 5 minutes), a fraction of non-renewable biomass of 82% (default value for Uganda provided by CDM), and an emission factor (default value for the conversion of TJ to tCO<sub>2</sub>) it was calculated that boiling 5,295 L of water leads to one ton carbon dioxide (tCO<sub>2</sub>) emissions. The baseline assumptions were validated and found correct by an independent auditor (so called ‘designated operational entity’ accredited by the UN).

After registration of the first component of the carbon project, Evidence Action was required to monitor the amount of chlorine used for water treatment and the water quality at the point of use – i.e. the total amount of safe drinking water consumed needs to be established during a specified monitoring period and then converted into emission reductions based on the baseline results (5,295 L = 1 tCO<sub>2</sub> = 1 carbon credit). Evidence Action’s field staff collects records for each chlorine delivery to a chlorine dispenser. During the first monitoring period (17/07/2014 to 31/01/2015) it was found that on average 23.8 L of chlorine were delivered per functional dispenser (1,049 out of 1,150 dispensers were found functional based on regular spot-checks conducted by Evidence Action). A survey including few hundred randomly selected households was used to determine microbial water quality in households that have total chlorine residual in their stored drinking water (= users). 93.5% of dispenser users were found to have safe water using the IDEXX Quanti-Tray method to test for E. coli. The CDM methodology accepts a quality threshold < 10 CFU/100 ml for E. coli.

## WATER QUALITY, SAFETY AND TREATMENT

### Water Treatment technologies and business models

Chlorine usage of 23.8 L corresponds to 158,667 L of treated water (3 mL per 20 L jerrican). Adjusted by 83.2% (fraction of treated water used for drinking as established in an additional household survey) and the fraction of water meeting the quality threshold, a total of 123,430 L of safe drinking water were used for drinking per functional dispenser during the first monitoring period (= 620 L per dispenser per day). Based on the conversion factor established in the baseline survey (i.e. the amount of CO<sub>2</sub> emissions that would have been emitted if the same amount of water had been boiled), approximately 25,000 carbon credits could be claimed for the first monitoring period. The monitoring report was verified and approved by an independent auditor. The auditor spent several days in the field to visit randomly selected chlorine dispensers and cross-check reported functionality rate and chlorine usage.

The first carbon credits were issued in April 2016. Once issued, the carbon credits need to be sold on the carbon compliance or voluntary market. South Pole Group’s dedicated sales team was able to sell the first 25,000 within few months. Carbon credits are a commodity and in order to sell carbon credits a broad network of corporate and public buyers is essential. In this case, the revenue from carbon credits is used to cover the carbon-related transaction costs (which is in the range of NGO’s expenditures for fundraising) and the profit is re-invested into the program to cover all operation and maintenance costs of the chlorine dispensers (which are below 1 USD per beneficiary per year). The carbon revenue allows Evidence Action to provide free access to chlorine for rural communities.

While the carbon markets are currently undergoing difficult times (i.e. the prices for carbon credits dropped dramatically in 2012/13), it is still possible to sell high-quality carbon credits (e.g. from attractive water projects in least developed countries) for relatively high prices. Nevertheless, even after the successful outcomes in Paris the future of the CDM is uncertain and one of the reasons for slowing down Evidence Action’s expansion in Uganda. The estimated annual issuance of carbon credits from the Uganda project over the next two decades is approximately 200,000, which assuming water supplies remain available, will provide continuous access to safe water for nearly 2 million people.

### Conclusions and Recommendations

- In Uganda, the high prevalence of boiling drinking water amongst households in the richest wealth quintile (77%) and low prevalence amongst the poorest (8%) provide a good basis for the “suppressed demand” assumption as indeed a major increase of fuel consumption for water treatment has to be expected as a result of economic development.
- The quantification of the emission reductions follows a methodology approved by the CDM (CDM, 2012). The methodology pursues a pragmatic approach, including some simplifications, to calculate the emission reductions in order to keep carbon-related transaction costs at a reasonable level. For instance, the methodology assumes heating the water from 20°C to 100°C and boiling it for 5 minutes - this may not be done by all households, however should be promoted in the absence of alternative treatment methods.
- Carbon finance is able to cover costs that traditional donors and governments are often not willing to cover, e.g. operation and maintenance costs. Carbon credits allow an innovative financing model for providing a basic water treatment option at no cost to the rural poor in Uganda. Even minimal costs are often a reason to exclude the poorest of the poor from the benefits of safe water interventions (J-PAL, 2011). Nevertheless, chlorine dispensers are only a treatment option for functional water supplies providing water with low turbidity.
- While Evidence Action’s operations already rely on a strong monitoring component, the carbon registration requires regular reporting of the results and cross-checks by an independent auditor. The first results show a high usage of chlorinated water (620 L per functional dispenser per day), relatively high functionality (91.2%) and high compliance with the required water quality threshold at the point of use (93.5%).
- The current situation of the carbon markets (i.e. prices below 1 USD per carbon credit) poses a risk to financing the operation and maintenance. However, high-quality carbon credits from water projects in least developed countries can still be sold for a multiple of the normal



## WATER QUALITY, SAFETY AND TREATMENT

### Water Treatment technologies and business models

commodity price. Preferably a forward contract (with pre-defined carbon credit volume and price) can be signed with a client, however it is not easy to find carbon credit buyers that are willing to do that. While the credits from the water project in Uganda are currently sold on the free market, Evidence Action and South Pole Group successfully secured such a forward contract for all carbon credits generated in Kenya and Malawi, which strongly reduces the operation and maintenance financing risks.

- Carbon finance is a results-based finance mechanism as carbon credits can only be generated (and consecutively sold) for drinking water that is safe and actually consumed. In case a forward contract with a pre-agreed price for carbon credits is in place, a known revenue can be generated for each meter cube of safe water consumed by the targeted beneficiaries.
- Under the Sustainable Development Goals water quality is given increased attention and it can be expected that decentralized water treatment options will gain traction (incl. chlorine dispensers but also household water treatment technologies and water kiosk solutions). The rural poor and most disadvantaged are most likely not able to cover the full costs of water treatment and some form of subsidy will be required. Results-based finance using an outcome-indicator (e.g. water free of faecal contamination at the point of use) provides possibly the best incentives for implementing cost-effective measures to reach a maximum number of people with a given budget. Carbon for water projects provide first concrete examples of results-based funded interventions and could be further expanded, or the learnings used for the development of similar new funding schemes.

### References

- CDM Executive Board (2012) *Low greenhouse gas emitting safe drinking water production systems. AMS.III-AV (ver 03)*.
- DHS Uganda (2011) *Uganda Demographic and Health Survey 2011. Kampala, Uganda: Uganda Bureau of Statistics (UBOS) and Calverton, Maryland: ICF International Inc.*
- Evidence Action (2013) *Dispensers for Safe Water. <http://www.evidenceaction.org/dispensersforsafewater>*
- Heierli, Urs and Osborn, Paul (2014) 'Going to scale with safe water – what changes are needed to remove the barriers to scale?' *Discussion paper for 300in6*
- Hodge James M. and Clasen, Thomas F. (2014) 'Carbon Financing of Household Water Treatment: Background, Operation and Recommendations to Improve Potential for Health Gains', *Environ. Sci. Technol.* 2014, 48, 12509–12515
- J-PAL (2011) 'The Price is Wrong', *J-PAL Bulletin April 2011, Abdul Latif Jameel Poverty Action Lab*

## WATER QUALITY, SAFETY AND TREATMENT

### Water Treatment technologies and business models

---

# Springhealth and the Paisa-Economics: the challenge to make the last mile distribution of safe water profitable

---

Type: Short Paper

#### Authors

- Urs Heierli, *Antenna Technologies Foundation, Geneva, Switzerland*, [ubeierli@antenna.ch](mailto:ubeierli@antenna.ch)
- Kishan Nanavati, *Springhealth Social Enterprise, Bhubhanesvar, India*, [kishan.nanavati@springhealth.in](mailto:kishan.nanavati@springhealth.in)

#### Abstract/Summary

This paper is about the challenge to deliver safe water to customers at the base of the pyramid in Orissa, India and make aspirational home delivery of chlorinated water profitable and affordable.

Springhealth is a promising business model to deliver chlorinated water in attractive jerry cans to villagers in rural Orissa at a fraction of the price of bottled water. Home delivery has proven to be an attractive and aspirational proposition: Getting safe water delivered daily at home with an auto-rickshaw raises their prestige of a family and raises their willingness to pay even if they are not aware that drinking contaminated water is a health threat. Many families in Orissa drink water from open wells and either think it is safe or they know it is unsafe and think, diarrhoea is part of daily life.

#### Introduction

Springhealth is a promising business model to deliver chlorinated water in attractive jerry cans to villagers in rural Orissa at a fraction of the price of bottled water. Home delivery has proven to be an attractive and aspirational proposition: Getting safe water delivered daily at home with an auto-rickshaw raises their prestige of a family and raises their willingness to pay even if they are not aware that drinking contaminated water is a health threat. Many families in Orissa drink water from open wells and either think it is safe or they know it is unsafe and think, diarrhoea is part of daily life. Springhealth (SH) is a social enterprise aiming at delivering safe water to BOP customers in India and making profit, so that it can go to scale. For the moment, Springhealth is only operating in Orissa. It has reached 260 villages and; it sells daily around 17,000<sup>156</sup> chlorinated 10 litre jerry cans, mostly home-delivered to some 31,000 customers (155,000 people).

#### Context, aims and activities undertaken

*Only few people are boiling the water regularly and the awareness to treat the water before drinking is very low. Springhealth has promoted its branded safe water through social marketing campaigns in schools, but the most attractive solution is to deliver safe water as an aspirational product or converting the delivery into a prestigious service that is at the same time affordable. The present price of 5 Rs per day (for 20 litres) is affordable for most villagers.*

Many users in rural Orissa are not very conscious about safe water and drink contaminated well water without any treatment. They are used to this water for generations, some know that it is contaminated but consider diarrhoea as part of daily life and nothing to be worried about, not even for their children. Springhealth has initiated awareness creation programs in schools, has organised so called “water testing melas” where villagers can bring their water for testing, and after 48 hours the petri-dishes with the

---

<sup>156</sup> Some customers do take the jerry can only every alternate day and some schools take 4 jerry cans and serve up to 150 pupils.

## WATER QUALITY, SAFETY AND TREATMENT

### Water Treatment technologies and business models

bacteria cultivation on their own water are shown to them. This is effective, but it may take a long time to change the mind-sets and behaviour of traditional village people.

The other strategy to overcome this hurdle is **making safe water aspirational** and include a status raising element into the product: such a differentiator is the “home delivery service” of safe water. When the delivery boy knocks at the doorbell every day, it raises the status of a family when the neighbours see that this family gets the water delivered at home – especially if it comes with an auto-rickshaw, a motorized tricycle. This is why almost 98 % of all SH customers are subscribed to home delivery; originally, this service was conceived as a special service for a few customers. The original pricing structure was 3 Rupees for collecting a jerry can at the water kiosk and 4 Rupees for the water delivered at home. Home delivery has thus become a kind of “packaging” safe water as an aspirational good just as a perfume is put in a nice bottle and wrapped in a luxury box.

However, the business model of SH is presently challenged in profitability; it still struggles to break-even, and this paper analyses some of the reasons for this.

### Main results and lessons learnt

*Rural wages have significantly increased in the last 5 years in India – from 100 Rupees to over 200 Rupees per day<sup>157</sup> – and this makes home delivery challenging because the delivery boy needs to make at least 250 Rs per day, today, compared to 100 Rs in 2010. The paper shows different ways how Springhealth has adapted its business model to these new circumstances.*

At the outset, not much has changed in rural India: the villages still look more or less the same, and one may get the superficial impression that nothing has changed. Poverty seems to prevail among the majority but small signs also indicate some progress: many houses are painted in bright colours, and mobile

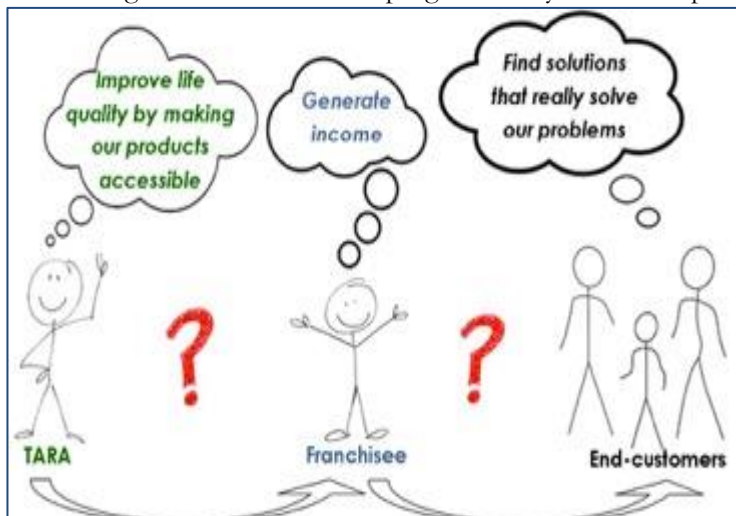

*This drawing shows the different objectives of the key players very well: while the agency (left) wants to supply safe water and “do good”, customers want an attractive solution: but the key is the person in-between, the delivery boy, dealer: he simply needs to make enough money.*

phones, TVs and even fridges are more common, even in villages. This does not mean that poverty is eradicated and the gap between the poorest and the rural lower middle classes may certainly have increased. But undoubtedly, rural wages have significantly gone up: In Orissa from 76 Rupees per day in 2010<sup>158</sup> to more than 200 Rupees today. While we assumed originally that a SH delivery boy would need to make at least 100 Rupees per day, this situation has dramatically changed now: not even 200 Rupees may be enough as a daily earning today. I met during my visit a rural entrepreneur whose business was to collect hair by going from house to house and asking women to sell him small balls of hair: he makes with that business 200 to 300 Rupees per day as he had proudly told me.

Pushing a tricycle through the village roads with 200 kg of water loaded is a much harder job than collecting hair.

<sup>157</sup> This fact may not be so visible in official statistics as it was a gradual increase over the last 5 years. The analysis by T.N.Ninan: „The Turn of the Tortoise – the Challenge and Promise of India’s Future“, shows the complex change of the rural realities and the impact of the State unemployment schemes. Delhi 2015, page 167ff.

<sup>158</sup> Government of India: „Wage Rates in Rural India, 2008 – 2009“, (no page numbers) showing that average wages were all over India less than 100 Rs, and in 2016 the Government of Odisha wanted to increase the minimum wage to 200 Rs, See Indian Express: „Revised MGNREGA wages puts States in a quandary“, April 3, 2106

## WATER QUALITY, SAFETY AND TREATMENT

### Water Treatment technologies and business models

On the other hand, prices for many things have gone up as well. Competing products such as bottled water (Bisleri Water) was priced in 2010 at 12 Rupees per litre and now at 18 to 20 Rupees; a 20 l jar has gone up from 40 to 60 Rs.

It was therefore necessary to overhaul the entire delivery policy of Springhealth. While bicycles – as originally planned – have soon shown not to be viable as they can only carry 6 to 8 jerry cans in one trip, the introduction of tricycles seemed to be more productive. The assumption was that if a delivery boy could deliver 100 jerry cans in a day and earn 1 Rupee per can, it would be feasible. However, earning 200 Rupees per day and delivering 200 cans is simply not possible. I have walked behind the tricycle and can now understand how demanding it is to push – not ride – a 200 kg tricycle through the narrow and bumpy roads of a village, especially when it is more than 40 °C hot. For this reason, SH introduced auto-rickshaws that can carry 80 jerry cans at a time, but an auto-rickshaw has also higher operating costs.

What is clear: home delivery is the very backbone and success factor of the Springhealth model, but making it profitable is really a logistical challenge. It is a task of *paisa-economics* and requires an extremely efficient delivery system. The solution may be to increase the price to 6 Rs per jerry can. However, such price adjustments are like an open heart surgery: if the price increase is too high, sales could drop dramatically.

### Conclusions and Recommendations

*Delivery of safe water must be aspirational, affordable but before all profitable, if broad masses can be reached and business models can go to scale.*

Springhealth is a very promising business model for safe water. Even if people are not aware that drinking contaminated water is bad for their health, they can become customers because of the **status value of the water**, especially due to the prestigious home delivery, a true innovation in rural villages. Springhealth – as every sustainable safe water delivery model – cannot go to scale unless it is profitable. No organization can deliver safe water at scale while losing money on each jerry can delivered. This is very simple and basic.

We have also to keep in mind how important it is to reach break-even in each village: as mentioned before, Springhealth needs in each village at least 85 customers (850 litres per day). In order to reach so many customers, it may be needed to increase the awareness creation and social marketing in achieve a higher market penetration. Social marketing activities should be financed with public money and not from the margins of the water, as health education is a public task and a public good.

### Safe water at the doorstep versus piped water – an intermediate solution?

When people are not aware that treating the water is necessary, the aspirational value of home-delivered jerry cans can jump over this barrier as a smart marketing strategy. But is this solution of delivering 20 litres per day (4 litres per person) really worth 5 or 6 Rupees? Obviously, it would be preferable if safe piped water were available in every household and Springhealth is not meant as an alternative to communal piped water systems. However, out of 157'000 villages in Orissa, only 35,233<sup>159</sup> have piped water so far and it may take decades until full coverage is achieved. And this option is also not free: there is also a fee of 150 Rs per month, but no doubt it is better to have a piped water access in the house providing much more water than Springhealth does. We should, however, also consider that often piped water is not safe at the point of use<sup>160</sup> and especially if piped systems are not always under pressure, recontamination can take place, also in the house. The Hystra study has also clearly shown<sup>161</sup> that different solutions need to be chosen for different situations such as population density, amount of water consumed. In this sense – similar to rural electricity – household water treatment solutions are most

<sup>159</sup> Odisha Sun Times Bureau: „55'000 Odisha villages go without safe drinking water“, February 18, 2016

<sup>160</sup> See Urs Heierli: „Marketing Safe Water Systems - -Why it is so hard to get safe water to the poor – and so profitable to the rich“, SDC Bern, 2006, page 25ff ( <http://www.poverty.ch/safe-water.html> )

<sup>161</sup> Hystra: “Access to safe water for the base of the pyramid”, Paris 2011, page 6ff ( <http://hystra.com/safe-water> )

## WATER QUALITY, SAFETY AND TREATMENT

### Water Treatment technologies and business models

appropriate for rural areas with a low population and a low consumption capacity per capita. Water supply systems are clearly subject to economies of scale.

Also, the Gram Vikas model is a very attractive vision: it forces the villagers to agree to total sanitation (no open defecation anymore) before a community water supply is established. We have not yet analysed the comparative costs of these different options, but it is a fact that Gramvikas has reached 190 villages in some 10 years of work and is covering 95'000 people. Springhealth has reached 234 villages with 150'000 people in only 4 years, and it can go to scale fast, if break-even is achieved. What is the better solution cannot be treated in this paper, and we do not argue that Springhealth would replace community based water supply system, delivering the entire water a household needs (40 litres per day). Springhealth is an intermediate and fast solution to make the drinking water safe at affordable prices, it is better to have a bird in the hand than two in the bush.

### Going to scale: the need to be profitable and for hybrid funding

It is important to observe good practices in using subsidies mainly for public tasks – all measures to increase market penetration and adoption through social marketing – and not subsidize the operational costs. Only then can the operation go to scale. However, there is no harm in using subsidies for awareness creation and social marketing efforts.

One of the challenges for scaling – as the report “Beyond the Pioneer”<sup>162</sup> points out – is that some of the barriers to scale do not lay within the firm but one has to look at the entire chain. The following picture shows that not only the firm has to be profitable, it must also have a viable value chain (last mile delivery), but for example awareness creation is a public good. There should indeed be social marketing activities that are implemented with public funds and not use the money of the social enterprise. We strongly plea for such social marketing campaigns that would increase the market penetration and make the marketing operations more profitable.

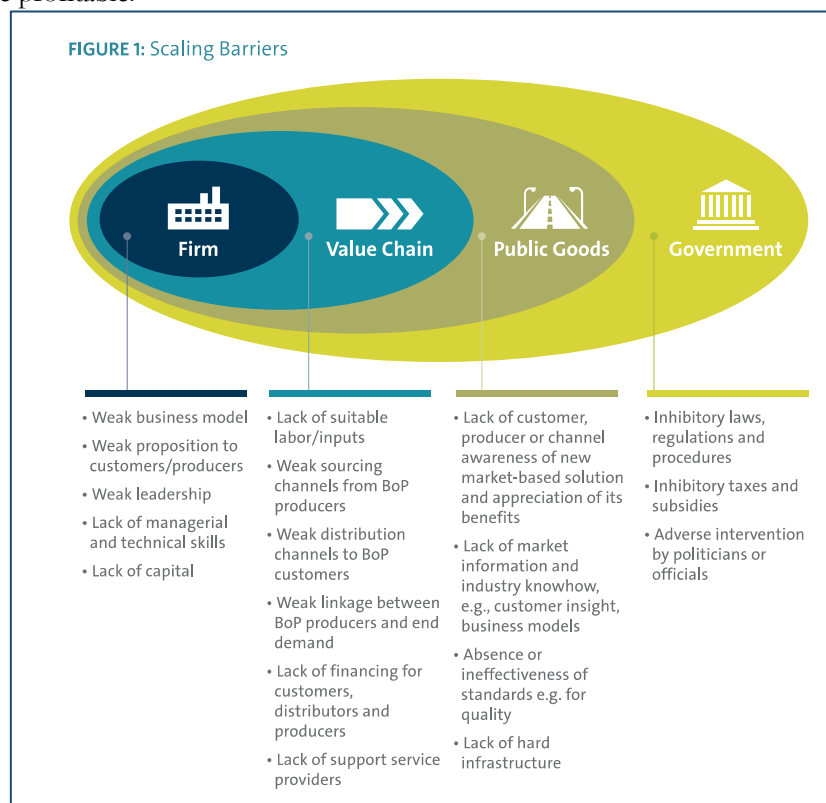

<sup>162</sup> Harvey Koh et al: “Beyond the Pioneer – Getting inclusive Industries to Scale”, Deloitte [www.deloitte.com](http://www.deloitte.com)

## WATER QUALITY, SAFETY AND TREATMENT

### Water Treatment technologies and business models

It may even be a very interesting and attractive option to subsidize social marketing activities as the social impact of such subsidies may be very high. At a first calculation, we arrived at around 100 Rs (US \$ 1.60) to reach one new beneficiary in existing villages. If we count 60'000 Rs needed for a repeated social marketing package per village (including marketing blitz, door-to-door visits, water testing mela, school program) and if this leads to 120 new customers (600 beneficiaries), we could estimate the cost of an additional person reached at 100 Rs. Such an impact may be too optimistic: but even if it is 300 Rs to reach out to a new regular customer, this would be a high-impact investment.

Springhealth and Antenna will now test such a strategy and undertake a measured experiment with different types of social marketing activities. The experiment will measure the cost of different activities in isolation and several activities combined and measure the impact these activities have on convincing new customers.

We should find out what works best as effective social marketing campaigns. We can distinguish between two major lines of social marketing:

- Above the line marketing: Above the line promotion activities are more rational activities such as water testing melas.
- Below the line marketing: these forms of promotion are more social activities that influence people through trusted persons. In this sense, word to mouth campaigns are more effective to influence people socially.
- What should be determined is what the right social marketing mix is and combine below the line promotion with above the line measures, massively.

### Conclusions and recommendations

The first priority is to strive for break-even and profitability. It is clear, however, that going to scale may need a combination of public and private investments in a mix of hybrid funding. Once social marketing activities are capable of creating sufficient market volumes, the rest should be a profitable operation, although challenged by wafer-thin margins, a high degree of efficiency and with a high quality of services. Then, we should be able to go to scale in the following 3 dimensions:

1. **Growth:** Increase numbers massively and reach in every village more than 85 customers. Expansion could then go to new villages and gradually scale-up the entire operation;
2. **Market penetration:** With better social marketing activities, we should also be able to go deeper and increase market penetration to 50 % or more
3. **Poverty:** By being viable and able to scale, the model should also become more inclusive and reach out to poorer households. This should not be done by subsidizing the operations, but results-based subsidies may especially target a better inclusion.

By no means would it mean to leave the aspirational path: we should not create a product for the poor. Maybe a price differentiation and product diversification can be the solution to breaking-even in a more challenging economic environment.

### Strategies to get back on the path to break-even again

Doing business at the base of the pyramid has several challenges to face. Customers have low purchasing power, they are reluctant to pay for safe water, and the cost of doing business in rural areas is high. In order to overcome these challenges, Springhealth has now undertaken massive changes in their business model, such as: a) increase the price from 4 Rs to 5 Rs per jerry can, b) increase sales volumes and market penetration in the villages (break-even in each village is achieved with 85 customers), c) reduce staff cost by increasing the productivity of each field staff, d) involve Self-Help Group women as distributors and

## **WATER QUALITY, SAFETY AND TREATMENT**

### **Water Treatment technologies and business models**

e) optimise the logistics of the home delivery. With all this, they have achieved almost break-even by end of April 2016. Springhealth has also been accepted by the Gold standard for voluntary carbon emissions. There are very promising growth perspectives available for the business model of Springhealth. The model is almost at the brink of being scalable. It is now fully tested and has been able to withstand major environmental changes such as a duplication of the rural wage structure. If it can overcome the present challenges, it may well become very soon ready to go to scale.

And, there are millions of people waiting for safe water.....

#### **Acknowledgements**

Springhealth is funded by SDC and other donors through Antenna Technologies Foundation.

WATER QUALITY, SAFETY AND TREATMENT

Water Treatment technologies and business models

4 FILMS

Title	Author/Presenter(s)	URL
<b>A borehole that lasts for a lifetime</b>	Kerstin Danert <sup>1</sup> , Sean Furey <sup>1</sup> , Vincent Casey <sup>2</sup> , Jose Gestí Canuto <sup>3</sup> , Dotun Adekile <sup>4</sup> , Cecilia Sharp <sup>3</sup> – <sup>1</sup> Skat Foundation <sup>2</sup> WaterAid UK, <sup>3</sup> UNICEF, <sup>4</sup> Independent	English: <a href="https://vimeo.com/128478995">https://vimeo.com/128478995</a> French: <a href="https://vimeo.com/130747716">https://vimeo.com/130747716</a>
<b>Drilling: the importance of borehole siting</b>	Kerstin Danert <sup>1</sup> , Sean Furey <sup>1</sup> , Vincent Casey <sup>2</sup> , Jose Gestí Canuto <sup>3</sup> , Dotun Adekile <sup>4</sup> , Cecilia Sharp <sup>3</sup> – <sup>1</sup> Skat Foundation <sup>2</sup> WaterAid UK, <sup>3</sup> UNICEF, <sup>4</sup> Independent	English: <a href="https://vimeo.com/126795160">https://vimeo.com/126795160</a> French: <a href="https://vimeo.com/130738245">https://vimeo.com/130738245</a>
<b>ECOLES BLEUES</b>	Monique Gbaguidi – HELVETAS Swiss Intercooperatio	<a href="https://www.youtube.com/watch?v=XL-LIaCBAWE">https://www.youtube.com/watch?v=XL-LIaCBAWE</a>
<b>Entrepreneurs for Water &amp; Water for Entrepreneurs (E4W &amp; W4E)</b>	Rik Haanen, Jacana SMART Centre Zambia	<a href="https://youtu.be/5rqn5xzi05A">https://youtu.be/5rqn5xzi05A</a>
<b>Evaluating water safety for supply schemes in remote areas. Novel approaches to comply with SDG 6.1 in rural Nepal</b>	Arnt Diener <sup>1</sup> , Sara Marks <sup>1</sup> , Moa Abate Kenea <sup>3</sup> , Irfan Yudha Pratama <sup>3</sup> , Mohan Bhatta <sup>2</sup> , Madan Bhatta <sup>2</sup> – <sup>1</sup> Swiss Federal Institute for Environmental Sciences and Technology (EAWAG), <sup>2</sup> HELVETAS Swiss Intercooperation, Nepal, <sup>3</sup> UNESCO-IHE	<a href="https://youtu.be/Pw36bz9LPvU">https://youtu.be/Pw36bz9LPvU</a>
<b>Four Steps to Better Drilling Contracts / Quatre étapes pour de meilleurs contrats de forage</b>	Kerstin Danert <sup>1</sup> , Sean Furey <sup>1</sup> , Vincent Casey <sup>2</sup> , Jose Gestí Canuto <sup>3</sup> , Dotun Adekile <sup>4</sup> , Cecilia Sharp <sup>3</sup> – <sup>1</sup> Skat Foundation <sup>2</sup> WaterAid UK, <sup>3</sup> UNICEF, <sup>4</sup> Independent	English: <a href="https://vimeo.com/171751215">https://vimeo.com/171751215</a> French: <a href="https://vimeo.com/185287147">https://vimeo.com/185287147</a>
<b>FundiFix in Kenya</b>	Jacob Katuva, Oxford University	<a href="https://youtu.be/WXUdquC4DBg">https://youtu.be/WXUdquC4DBg</a>
<b>Mini-Réseaux Solaires – Une eau de proximité, Bénin [273]</b>	Monique Gbaguidi, Virginie Peytoureau – Helvetas Swiss Intercooperation Benin	<a href="https://youtu.be/vL5Cr3TbjKY">https://youtu.be/vL5Cr3TbjKY</a>
<b>Searching for sustainability of rural water supply: a snapshot of perspectives of 14 countries across Asia</b>	Susanna Smets <sup>1</sup> , Antoinette Kome <sup>2</sup> , Almud Weitz <sup>1</sup> , Sean Furey <sup>3</sup> – <sup>1</sup> The World Bank, <sup>2</sup> SNV <sup>3</sup> Skat Foundation	<a href="https://youtu.be/25a6_iTCnV4">https://youtu.be/25a6_iTCnV4</a>



WATER QUALITY, SAFETY AND TREATMENT

Water Treatment technologies and business models

Title	Author/Presenter(s)	URL
<b>Sustainable WASH Services for Complex Emergency Countries: Approaches from the Central African Republic</b>	David DeArme, Jon Allen, Adrienne Lane – Water for Good	<a href="https://vimeo.com/193098796/c0b0355eec">https://vimeo.com/193098796/c0b0355eec</a>
<b>The power and potential impact of sand dams</b>	Simon Maddrell – Excellent Development	<a href="https://youtu.be/SUNpjlNq2o0">https://youtu.be/SUNpjlNq2o0</a>
<b>Traitement et bonne conservation d'eau à domicile en Guinée</b>	Pierre-Gilles Duvernay <sup>1</sup> , Aboubacar Camara <sup>2</sup> – <sup>1</sup> Fondation Antenna Technologies, <sup>2</sup> Tinkisso-Antenne	<a href="https://youtu.be/hpfqygLCC0Y">https://youtu.be/hpfqygLCC0Y</a>
<b>Transformation des puits à grand diamètre au Bénin</b>	Alice Chabi Guiya, – HELVETAS Swiss Intercooperation Bénin	<a href="https://www.youtube.com/watch?v=RfXmamOCjUQ">https://www.youtube.com/watch?v=RfXmamOCjUQ</a>
<b>Ukraine: Way Towards Good Governance in Rural Water Supply</b>	Viacheslav Sorokovskiy, – Swiss-Ukrainian Decentralisation Support Project DESPRO	<a href="https://vimeo.com/191648323">https://vimeo.com/191648323</a>
<b>Water Well Design and Construction Quality</b>	Vincent Casey <sup>2</sup> , Kerstin Danert <sup>1</sup> , Jose Gestí Canuto <sup>3</sup> , Rachel Geddes <sup>4</sup> , Dotun Adekile <sup>5</sup> – <sup>1</sup> Skat Foundation <sup>2</sup> WaterAid UK <sup>3</sup> UNICEF, <sup>4</sup> National Ground Water Association, <sup>5</sup> Water Surveys and Resources Development Limited	English: <a href="https://vimeo.com/185289895">https://vimeo.com/185289895</a> French: <a href="https://vimeo.com/185292448">https://vimeo.com/185292448</a>