

**VENT-O-MAT<sup>®</sup>**

## **SERIES RGXII**

**“ANTI-SURGE”**

**SEWAGE AIR RELEASE AND VACUUM BREAK VALVES**

**FOR EFFECTIVE AIR RELEASE, VACUUM PROTECTION AND  
SURGE ALLEVIATION**



**DFC**  
DYNAMIC  
FLUID CONTROL

# VENT-O-MAT<sup>®</sup>

## AIR RELEASE & VACUUM BREAK VALVES SERIES RGXII “ANTI - SURGE”

The Unique defence against pipe bursts and pipeline system damage!

The Vent-O-Mat Series RGXII "Anti-Surge" sewage air release and vacuum break valve, is an evolution of market feedback and the incorporation of the already proven Vent-O-Mat technology which itself resulted from years of extensive research. The valve unlike many others is not just an adaption of an air valve to handle sewage valve but the result of over 30 years of dealing with sewage and seeing what works and adapting it to the needs of the end user

The basis of the Vent-O-Mat design is in the understanding of the physical laws that govern air valve and pipeline operation. Reaction to pipeline dynamics is therefore instantaneous and protection provided is relevant to the pipeline's needs.

Vent-O-Mat Series RGXII truly represents the pinnacle of valve design evolution. This valve design provides the most comprehensive, effective and efficient pipeline protection relative to initial cost of any other available pipeline component. This can easily be gauged from the below:

### Automatic Surge Protection

The unique Series RGXII valve incorporates as standard, three design features to automatically protect a pipeline, under all pipeline operating conditions, from the destructive surge and water hammer phenomena. These features are independent of any mechanical devices ensuring reaction in a very low millisecond time span.

### Effective Air Release

The RGXII design ensures effective de-aeration under all pipeline flow and operating conditions, via either one of three discharge orifices.

### Vacuum Protection

The RGXII series large orifice diameters equal the nominal size of the valve. This ensures the least possible resistance to the intake of air and consequently the least possible negative pressure within a draining pipeline. The use of solid, cylindrical floats ensures instantaneous reaction, discourages the "Venturi" phenomenon and is a further guarantee of effective vacuum protection.

### Guaranteed Performance

The RGXII has been designed and developed to provide the optimum usable and safe performance relative to all functions. Selection data has been substantiated through third party testing and can therefore be confidently referenced.

The surge protection function of the RGXII design has been incorporated in the well-known **SURGE 2000** surge analysis software program and can be analyzed with great accuracy in other commercially available surge analysis programs such as FLOWMASTER and TRANSAM.

### Unparalleled Service

Vent-O-Mat is committed to customer service and to the selling of solutions. Our highly dedicated team is available at all times to assist with air valve sizing and positioning. Assistance is also provided in finding the most cost effective and/or efficient surge protection strategy relevant to the pipeline's needs.

### International Representation

Vent-O-Mat is represented in the following countries and regions:

- |                        |            |                |               |             |
|------------------------|------------|----------------|---------------|-------------|
| * USA                  | * Thailand | * South Africa | * Namibia     | * Kuwait    |
| * Canada               | * Germany  | * Zimbabwe     | * Hong Kong   | * Brazil    |
| * Caribbean            | * Kenya    | * Tanzania     | * Taiwan      | * France    |
| * United Arab Emirates | * Egypt    | * Malawi       | * New Zealand | * Singapore |
| * South America        | * UK       | * Zambia       | * Vietnam     | * Australia |

# CATALOGUE INDEX

<b>Introduction</b>	1
<b>Recommended Installation Arrangements</b>	2
<b>Operation</b>	3
<b>Available Discharge Connections</b>	4
<b>Component Description &amp; Material Specification</b> Epoxy Coated Cast Body - Flanged Inlet DN50 (2") to DN200 (8")	5
<b>General Specifications</b> Epoxy Coated Cast Body - Flanged Inlet DN50 (2") to DN200 (8")	6
<b>Component Description &amp; Material Specification</b> Full Stainless Steel Body - Threaded Inlet DN50 (2") and Flanged Inlet DN50 (2") to DN200 (8")	7
<b>General Specifications</b> Full Stainless Steel Body - Threaded Inlet DN50 (2") and Flanged Inlet DN50 (2") to DN200 (8")	8
<b>Small Orifice Discharge Performance</b>	9
<b>Selection and Positioning</b>	10 & 11
<b>Surge and Water Hammer Protection</b>	12
<b>Purchase Specification</b>	13
<b>Ordering Guide</b>	14

- **DESIGN** - the RGX II has been designed owing to customer demand. When taking into account customer requests that influenced the design, key benefits that Vent-O-Mat was originally famous for was not compromised but further ones were incorporated into the new design.
- **"ANTI - SHOCK" - "ANTI - SURGE"** - The RGX II is a air release valve that is supplied as standard with a mechanism to prevent pipeline damage from the high induced pressure transients associated with high velocity air discharge. Surge resulting from liquid column separation and liquid oscillation is dramatically reduced as an automatic function of this mechanism. this same mechanism allows for controlled filling of the pipeline, maintaining controlled discharge at all times.
- **COMPACTNESS** - The RGX II is more compact and shorter without compromising the pressure rating of the valve.
- **FULL PORT OPENING ON NEGATIVE PRESSURE** -During pipeline draining and instance of surge, the valve will allow the intake of air to the full nominal bore of the of the valve. The RGX II series large orifice diameters equal the nominal size of the valve, i.e., a 8" valve has a 8" orifice. This ensures the least possible resistance to the intake of air and consequently the least possible negative pressure within a draining pipeline.
- **SEALING** - The RGX II has been designed for low head sealing as well where line pressures are generally lower than normal.
- **MATERIALS** - The RGX II is now available with a fusion bonded Ductile Iron Body as well as a 304 or 316 Stainless Steel Body.
- **PERFORMANCE** - The RGX II has been designed and developed to provide the optimum usable and safe performance relative to all functions.
- **QUALITY** - The RGX II economically offers the highest quality construction and materials available in an air release and vacuum break valve. Stringent manufacturing and test procedures are maintained to ensure the best possible service and reliability is given by every valve produced.
- **SERVICEABILITY** - The RGX II design facilitates extreme ease of service and maintenance. Components are in corrosion free materials to allow problem free disassembly and reassembly even after many years of operation. All maintenance spares are replaceable without special tools or skills.
- **BACK UP** - Vent -O- Mat provides highly committed customer orientated sales, service, spares and technical back up - TRY US!!!

**RECOMMENDED INSTALLATION ARRANGEMENTS**

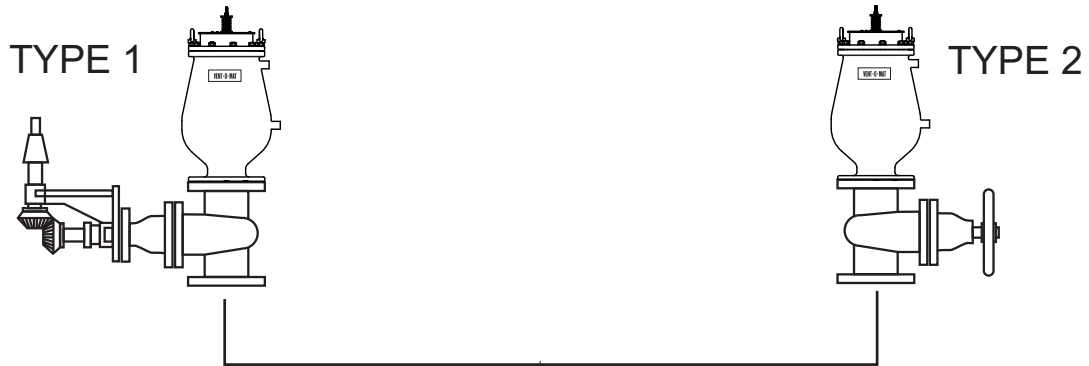

THE DEGREE OF TOLERANCE ALLOWED FOR THE EFFECTIVE OPERATION OF A VENT-O-MAT AIR RELEASE AND VACUUM BREAK VALVE IS **3 DEGREES FROM VERTICAL**

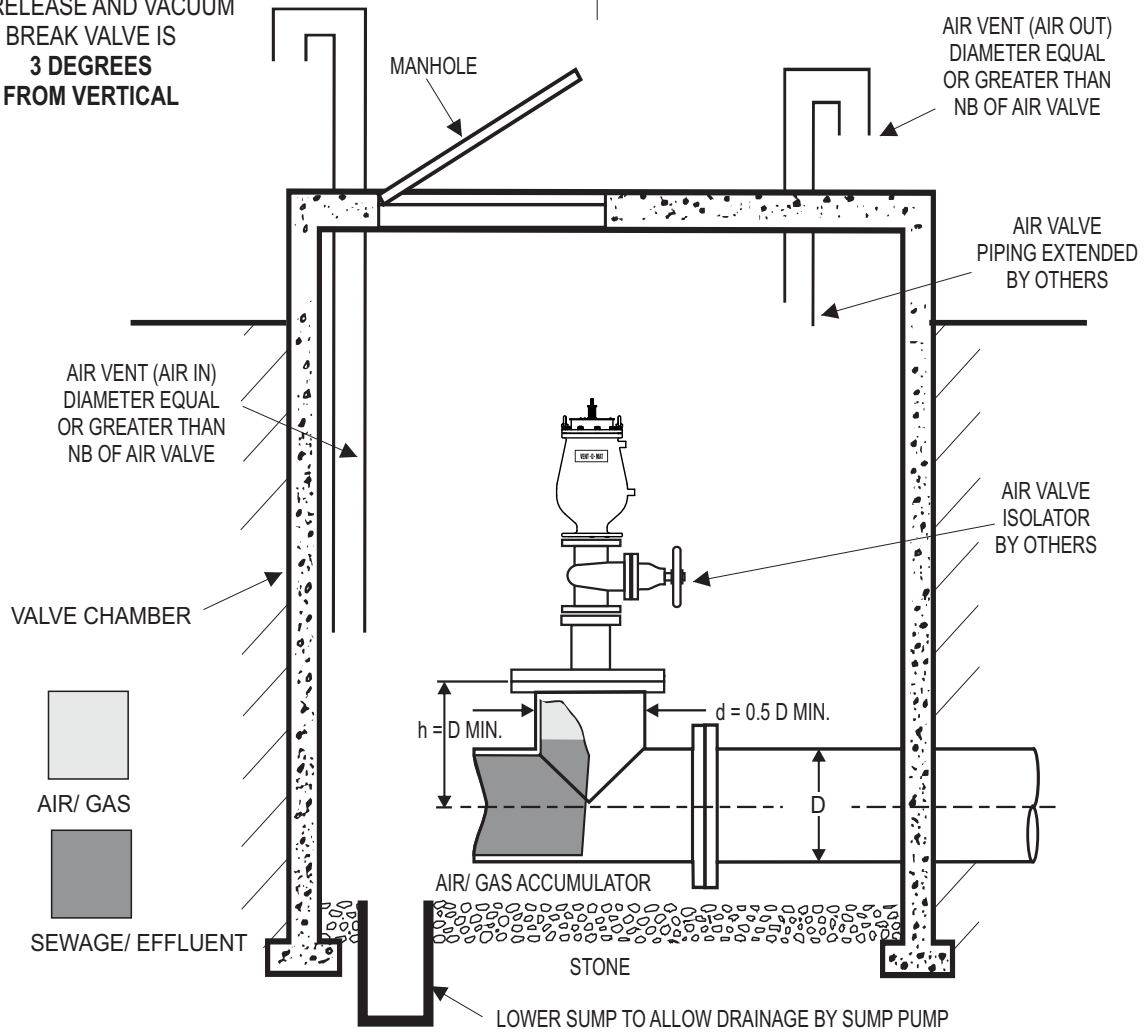

**TYPICAL VALVE CHAMBER**

## Series RGXII OPERATION

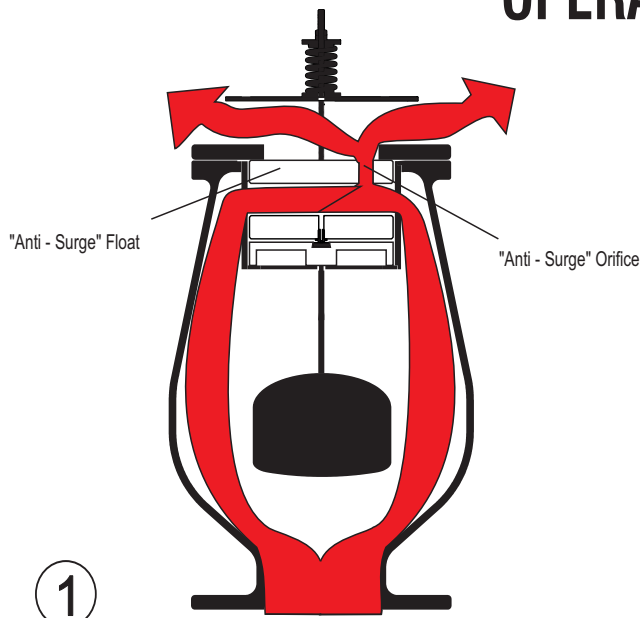

**1**  
PIPELINE FILLING  
(SUB CRITICAL AND EXCESSIVE  
SEWAGE/ EFFLUENT APPROACH VELOCITY)

Air/gas flows through the annular area around the control float assembly and to atmosphere through the large orifice.

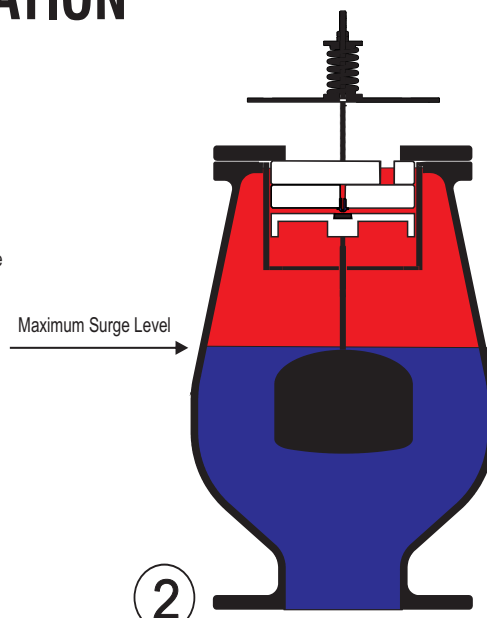

**2**  
PIPELINE FULLY CHARGED

Sewage/effluent has entered the valve chamber and buoyed the floats to close both the large and the small orifice. The design's compression/ volume relationship prevents the media from ever exceeding the maximum surge level indicated above. The resultant sewage/ effluent force against the orifice seals by solids or high viscous substances

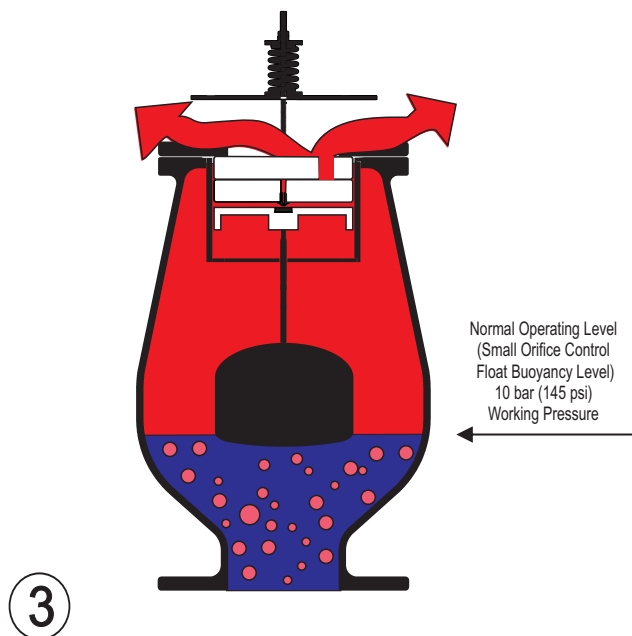

**3**  
PRESSURIZED AIR/GAS RELEASE  
PIPELINE OPERATING

The volume of disentrained air/gas increases in the valve, displacing the sewage/effluent to below the normal operating level. This results in the control float dropping away from the small orifice. The pressurized air/gas is then discharged to atmosphere. Once all additional air is discharged the control float will close the small orifice. Restore the sewage effluent to the normal operating level.

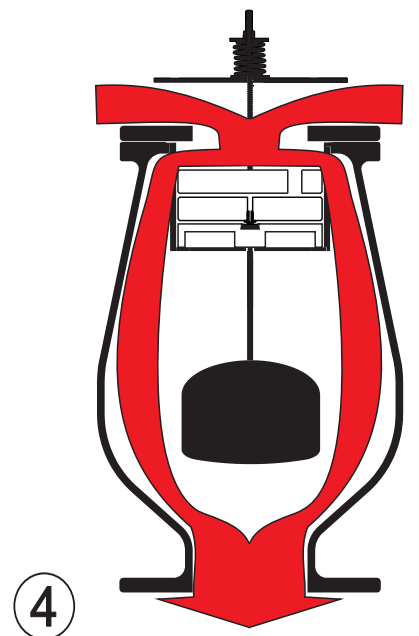

**4**  
VACUUM RELIEF (AIR INTAKE)  
PIPELINE DRAINING

Upon pump stop, Sewage/effluent drains from the sewage air valve and The negative differential created by the draining liquid causes atmospheric air to push the "Anti-Surge" Float down, opening the Large Orifice and allows air to displace the draining liquid to prevent potentially damaging internal negative pressure.

**AVAILABLE DISCHARGE CONNECTIONS  
DN50 (2") TO DN200 (8")**

Standard Screen Discharge  
50 mm (2") to 200mm (8")

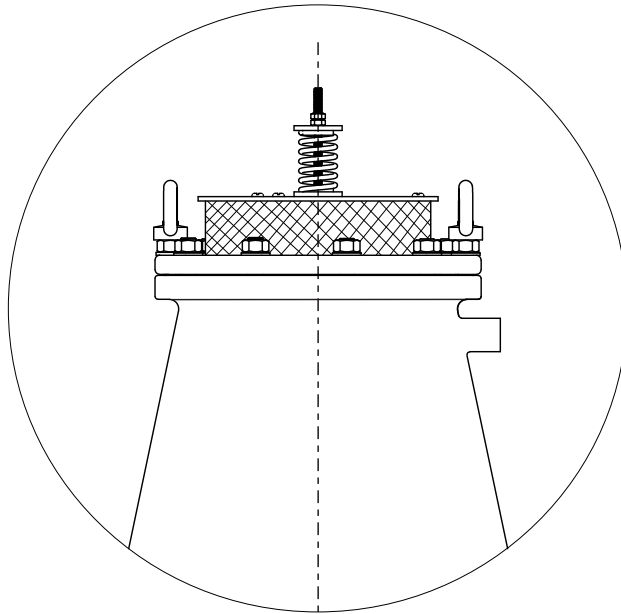

---

**Alternative Arrangements can be provided on request**

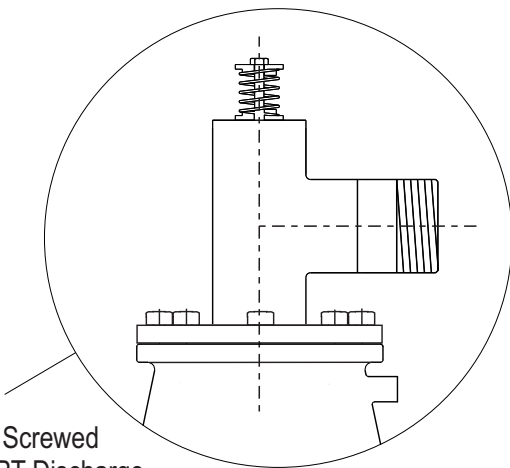

Biased Screwed  
BSP/NPT Discharge  
50mm(2"), 80mm (3") &  
100mm (4") Valves only.

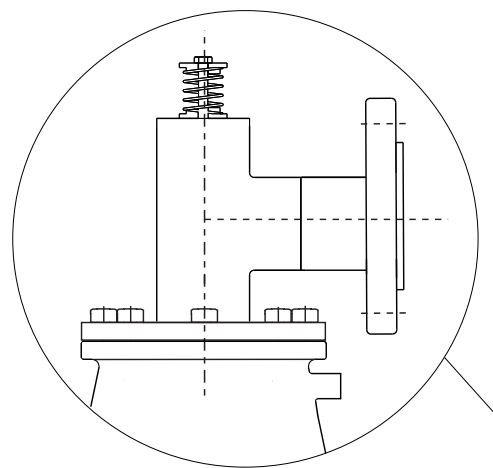

Biased  
Swivel Discharge  
50 mm (2") to 200mm (8")

\*NOTE  
Discharge Connections Are Equal To Valve Pressure Rating  
Information subject to change without prior notice

## COMPONENT DESCRIPTION & MATERIAL SPECIFICATION FLANGED - DN50(2") - DN200(8")

**Type:**  
Series RGX II - Double Orifice (Small & Large Orifice)  
with Anti Shock Orifice Mechanism.

**End Connection:**  
Flanged

**Nominal Sizes:**  
DN50(2") - DN200(8")

**Model No's:**  
RGXII 1001 & 1031 \_\_\_\_\_  
RGXII 1601 & 1631 \_\_\_\_\_

**Pressure Ratings:**  
PN10 (145 psi)  
PN16 (232 psi)

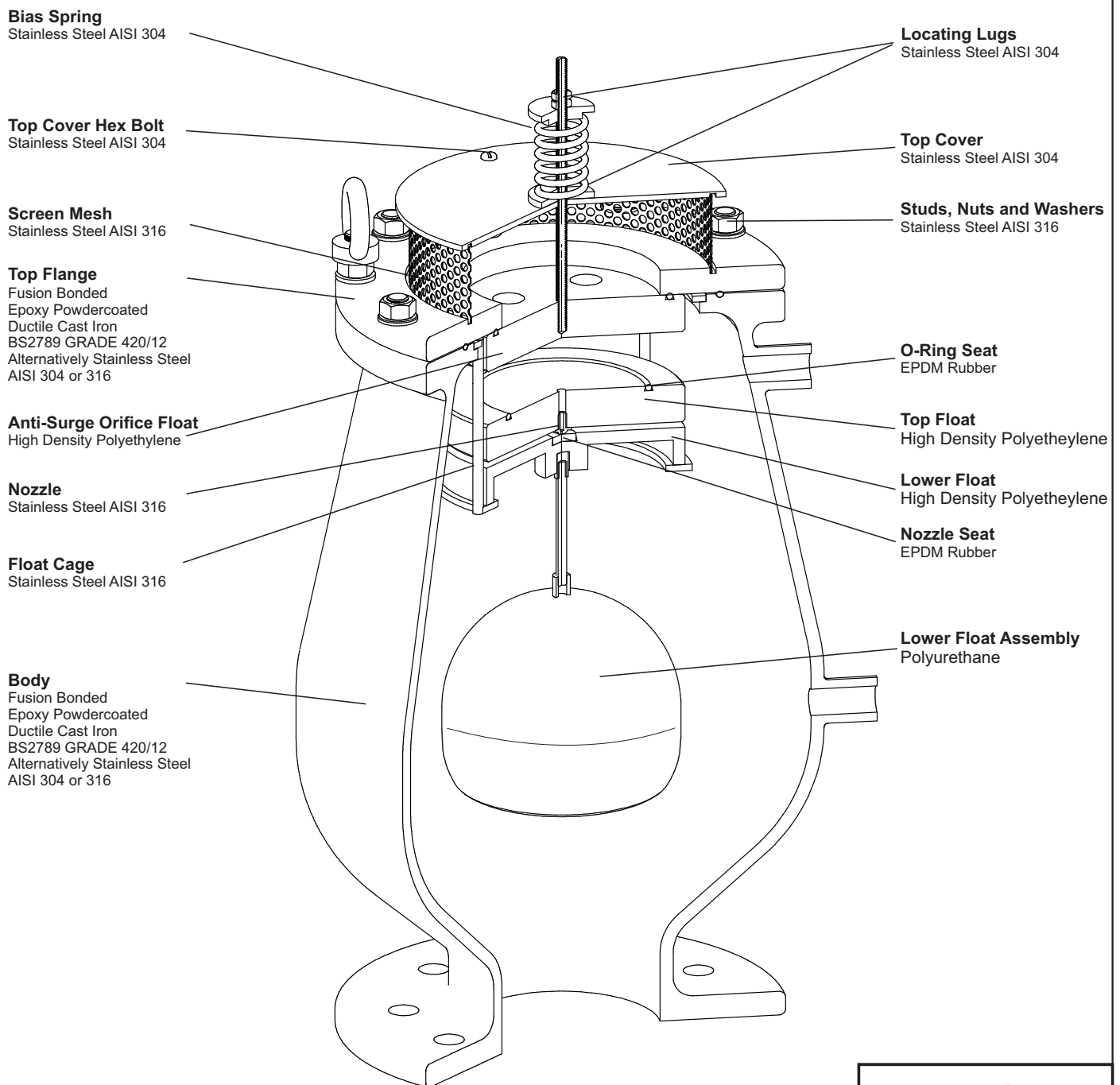



## GENERAL SPECIFICATIONS FLANGED 50 (2") TO 200 (8")

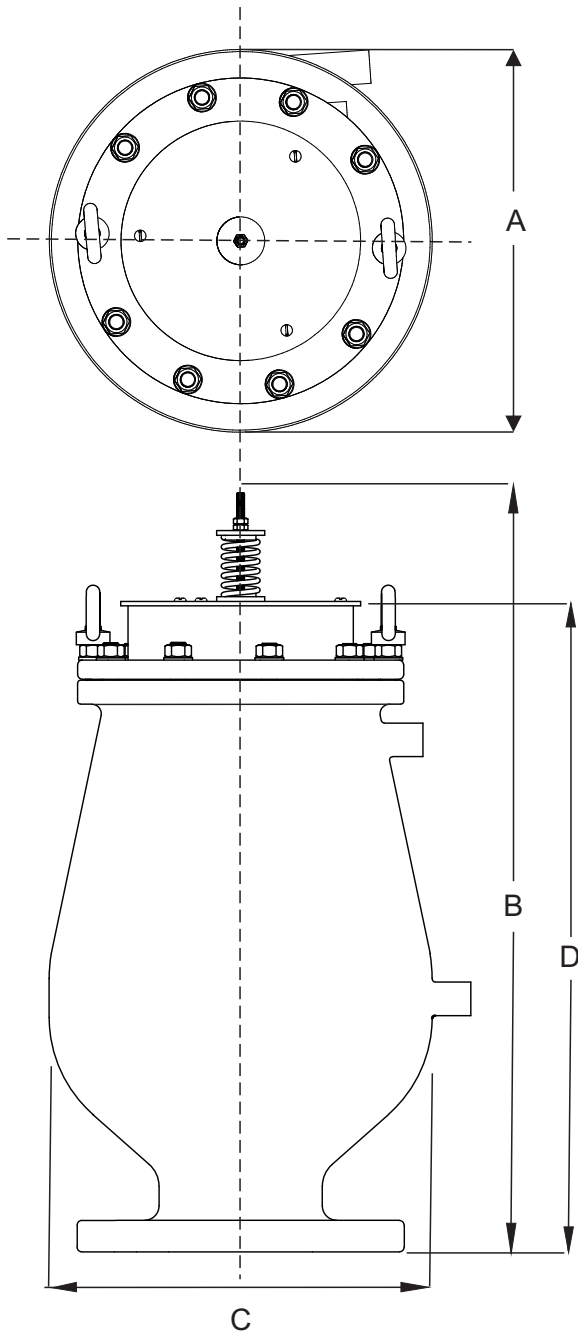

**Type:**

Double Orifice (Small & Large Orifice) with Bias mechanism for large volume air intake and controlled air discharge.

**End Connection:**

Flanged - BS EN 1092 Table 10 / 16  
Flanged - ASME B16.5 Class 150

**Nominal Sizes:**

DN50 (2"), DN80 (3"), DN100 (4"), DN150 (6") & DN200 (8")

**Operating Temperature Range:**

4° C (40°F) to 80°C (176°F)

**Model No's:**

RGXII 1001 / 1031  
RGXII 1601 / 1631

**Operating Pressure**

PN10 (145 psi)  
PN16 (232 psi)

**Function:**

- i) High volume air intake - pipeline draining
- ii) Pressurized air/gas discharge - pipeline filled.
- iii) Controlled air discharge - pipeline filling.
- iv) Surge dampening - high velocity air/gas discharge, liquid column separation & liquid oscillation.

**Valve Selection:-** Pages 10 - 11

**Materials of Construction:-** Page 5

**Installation:-** Page 2

**Standard Factory Tests:**

- i) Hydrostatic test -1.5 x max. rated working pressure
- ii) Low head leak test - 0.2 bar (2.9 psi)
- iii) Small orifice function test at max. rated working pressure (minimum 1 valve in 10).

## OVERALL DIMENSIONS & WEIGHTS

DN		Model No.	A		B		C		D		Weight S/Steel		Weight Cast	
mm	in		mm	in	mm	in	mm	in	mm	in	kg	lbs	kg	lbs
50	2	050 RGXIIb 1011/21 & 1611/21	174	7	413	16	155	6	363	14	13	29	16	35
80	3	080 RGXIIb 1001/31 & 1601/31	230	9	640	25	273	11	546	22	30	66	40	88
100	4	100 RGXIIb 1001/31 & 1601/31	230	9	645	25	273	11	546	22	30	66	40	88
150	6	150 RGXIIb 1001/31 & 1601/31	340	13	772	30	400	14	680	28	60	132	70	154
200	8	200 RGXIIb 1001/31 & 1601/31	355	14	940	37	526	21	846	33	80	176	115	253

**COMPONENT DESCRIPTION & MATERIAL SPECIFICATION**  
**FULL STAINLESS STEEL BODY**  
**THREADED INLET DN50 (2") & FLANGED INLET DN50 (2") - DN200 (8")**

**Type:**  
 Series RGX II - Double Orifice (Small & Large Orifice)  
 with Anti Shock Orifice Mechanism.

**End Connection:**  
 Flanged

**Nominal Sizes:**  
 DN50(2") - DN200(8")

**Model No's:**  
 RGXII 1001 & 1031  
 RGXII 1601 & 1631

**Pressure Ratings:**  
 PN10 (145 psi)  
 PN16 (232 psi)

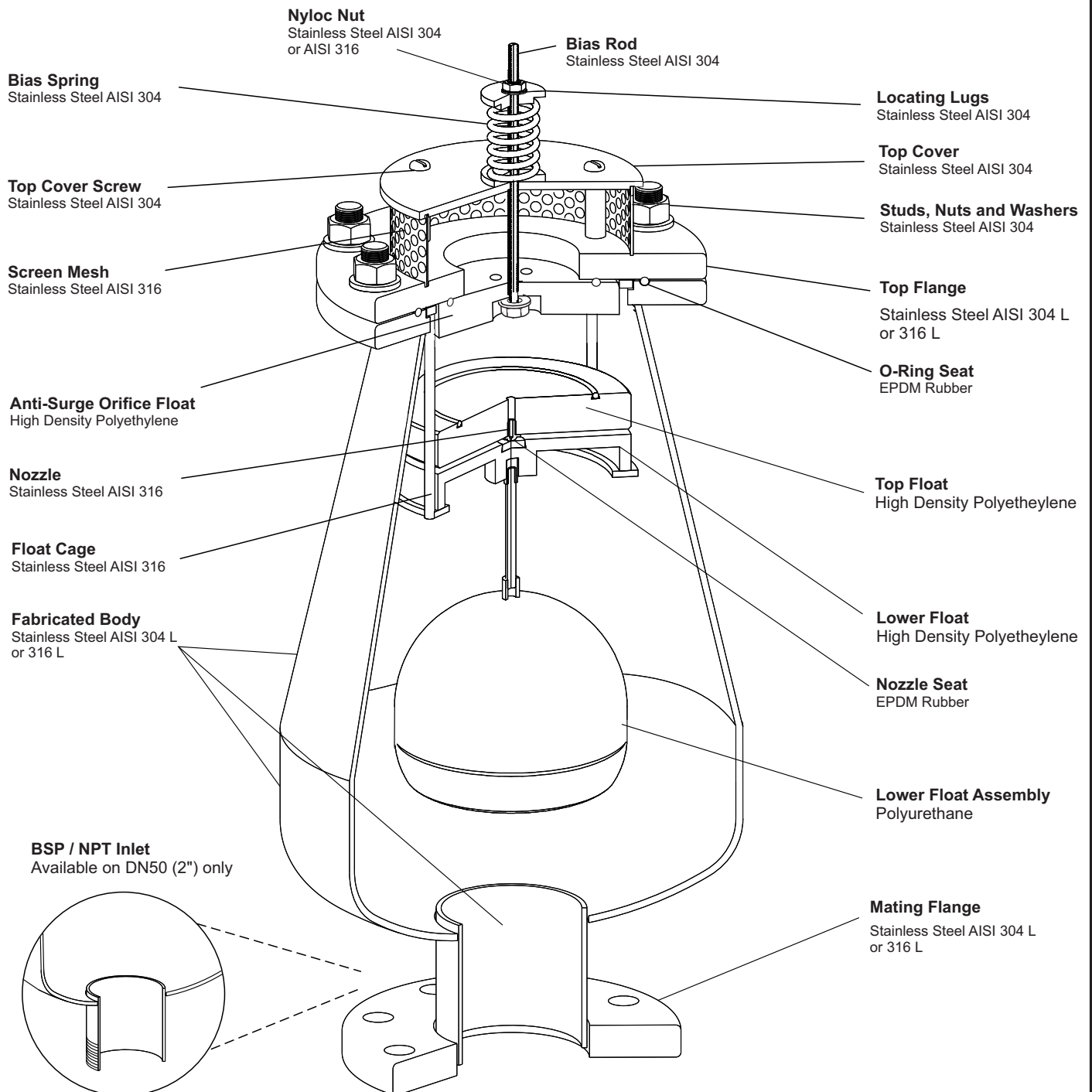

### GENERAL SPECIFICATIONS FULL STAINLESS STEEL BODY

**THREADED INLET DN50 (2") & FLANGED INLET DN50 (2") - DN200 (8")**

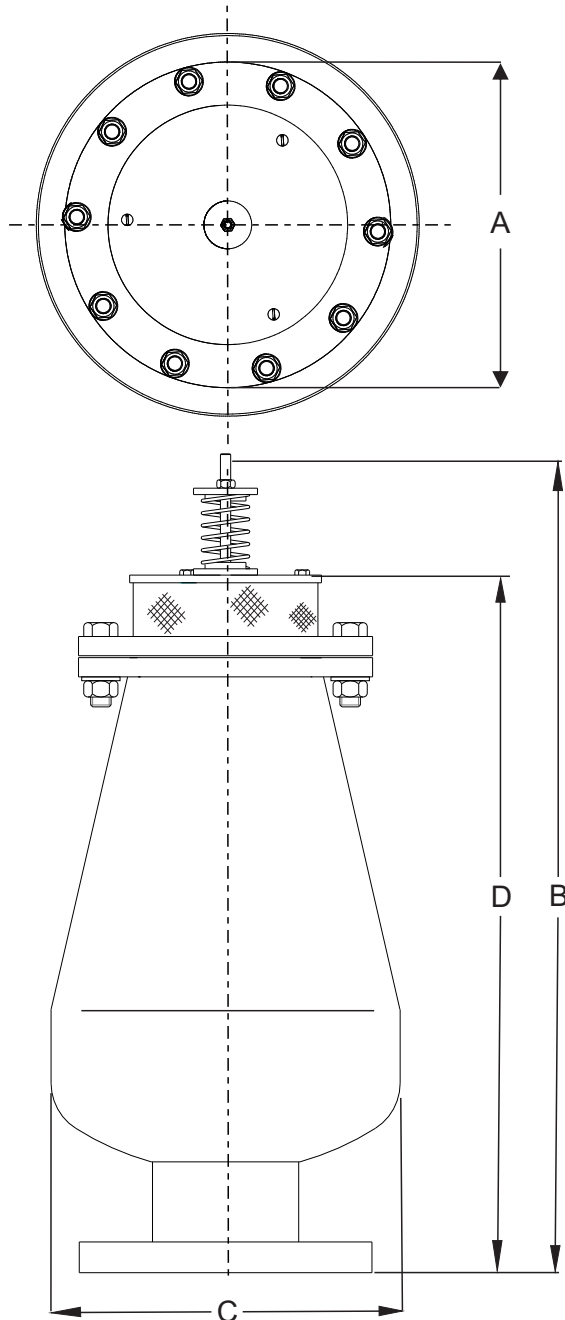

**Type:**

Double Orifice (Small & Large Orifice) with Bias mechanism for large volume air intake and controlled air discharge.

**End Connection:**

Screwed BSP / NPT DN50 (2") only  
Flanged - BS EN 1092 Table 10 / 16  
Flanged - ASME B16.5 Class 150

**Nominal Sizes:**

DN50 (2"), DN80 (3"), DN100 (4"), DN150 (6") & DN200 (8")

**Operating Temperature Range:**

4°C (40°F) to 80°C (176°F)

**Model No's:**

RGXII 1001 / 1031  
RGXII 1601 / 1631

**Operating Pressure**

PN10 (145 psi)  
PN16 (232 psi)

**Function:**

- i) High volume air intake - pipeline draining
- ii) Pressurized air/gas discharge - pipeline filled.
- iii) Controlled air discharge - pipeline filling.
- iv) Surge dampening - high velocity air/gas discharge, liquid column separation & liquid oscillation.

**Valve Selection:-** Page 10 - 11

**Materials of Construction:-** Page 7

**Installation:-** Page 2

**Standard Factory Tests:**

- i) Hydrostatic test -1.5 x max. rated working pressure
- ii) Low head leak test - 0.2 bar (2.9 psi)
- iii) Small orifice function test at max. rated working pressure (minimum 1 valve in 10).

### OVERALL DIMENSIONS & WEIGHTS

DN		Model No.	A		B		C		D		Weight S/Steel	
mm	in		mm	in	mm	in	mm	in	mm	in	kg	lbs
50	2	050 RGXIIb 1011/21 & 1611/21	174	7	410	16	141	6	360	14	13	29
80	3	080 RGXIIb 1001/31 & 1601/31	230	9	650	25	273	11	550	22	30	66
100	4	100 RGXIIb 1001/31 & 1601/31	230	9	650	25	273	11	550	22	30	66
150	6	150 RGXIIb 1001/31 & 1601/31	340	13	798	30	406	16	704	28	60	132
200	8	200 RGXIIb 1001/31 & 1601/31	355	14	950	37	508	20	856	34	80	176

### SMALL ORIFICE DISCHARGE PERFORMANCE

**Type:**  
 Series RGXI**b** - Double Orifice (Small & Large Orifice) with "Anti-Surge" Orifice Mechanism

**Model No's:**  
 RGXI**b** 1001/31  
 RGXI**b** 1601/31

- █ 2mm (0.07") small orifice - DN50 (2"), DN80 (3"), DN100 (4") Valves
- █ 5mm (0.20") small orifice - DN150 (6") Valves
- █ 6mm (0.24") small orifice - DN200 (8") Valves

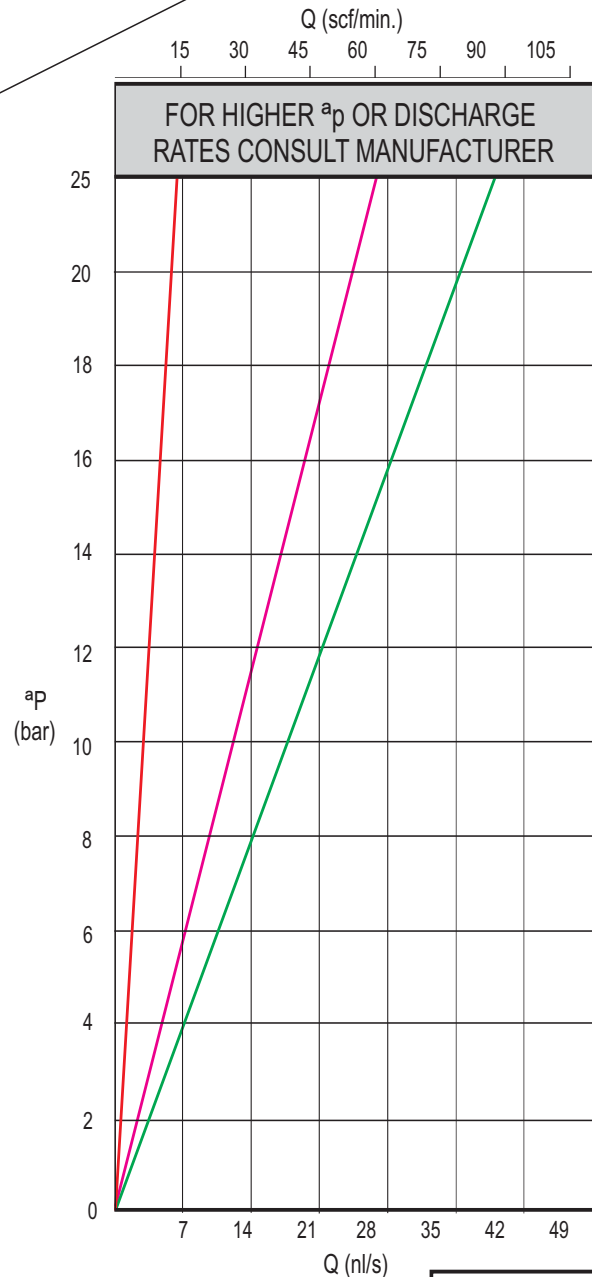
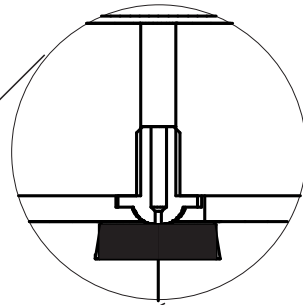
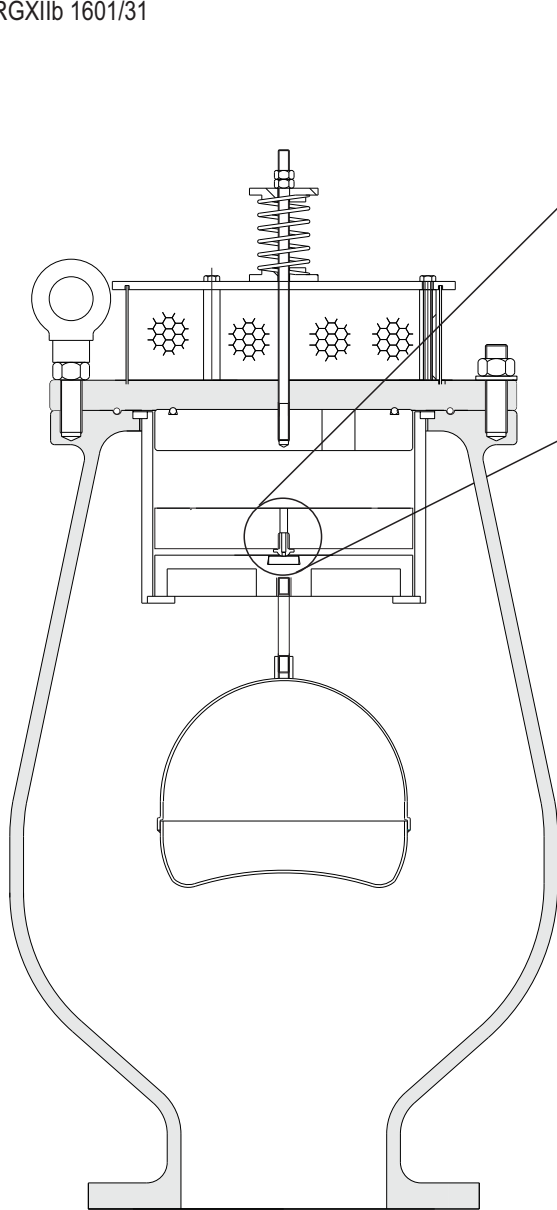

Q = Normal Litres per second (Free Air) @ 1.01325 bar Abs. and 20 deg. C	Q = Standard Cubic Feet per minute (Free Air) @ 14.7 psi Abs. 68 deg. F
<b>CONVERSION EQUIVALENTS</b>	
1 l/ sec. = 2.1189 scf/ min.	1 scf/ min = 0.472 l/ sec.
1 bar = 14.5 psi	1 psi = 0.069 bar

## SELECTION & POSITIONING

### VALVE SELECTION FROM GRAPH

All the relevant information has been condensed into one graph to enable valve selection to be simple and easy and at the same time to allow flexibility to the designer to move within certain parameters which eventually allows the most suited and economically viable valve to be selected.

**IMPORTANT NOTE:** The graph is based on vacuum breaking and limiting vacuum to 0.34 bar (5 psi) below atmospheric. It is not good practice to go below 0.69 bar (10 psi) absolute (0.303bar (4.4 psi) differential in pipeline at sea level). The graph allows for change in altitude and hence change in atmospheric pressure and is based on the assumption that more than one valve per section is used for vacuum protection and venting

### ACTUAL SELECTION ( GRAVITY OR PUMPED PIPELINES)

Selection is based on the premise that pipelines are generally filled at a slower rate than they are drained, scoured or at which separation occurs (a maximum fill/ drain ratio of 1:1).

1. Determine the maximum drainage rate in m/s either for scouring, pipe rupture or column separation for a particular pipeline section.
2. Move vertically on the graph from the m/s point and move horizontally from the pipe size finding the intersecting point.
3. This point should fall within the operating band of a particular valve size. Consideration must be given to the fact that the upper portion of the band approaches - 0.34 bar (5 psi) and the lower portion - 0.1 bar (1.45 psi) for each valve size, this allows the designer to see at a glance if the valve is too close to it's operating limits and to select the next valve size.

### EXAMPLE OF VALVE SIZING (ASSUMING AN INDIVIDUAL SECTION)

A  $\varnothing$  400mm (16") pipeline draining at 377l/sec which equates to 3m/sec (10ft/s) what valve size should be selected?

From the 3m/sec (10ft/s) point, move vertically until the  $\varnothing$  400mm (16") pipe size horizontal line is intersected. This places the intersection point squarely in the centre of the operating band of a DN80 (3") Vent -O- Mat RGX valve. But, if for example, the drainage rate is 503l/sec which equates to 4m/sec (13.2ft/s), the valve would be operating on it's limit and it may be prudent to change to a DN100 (4") Vent -O- Mat RGX.

### VALVE POSITIONING

1. ON APEX POINTS (relative to hydraulic gradient).
- 5 METERS (16 FEET) BELOW APEX POINTS FORMED BY INTERSECTION OF PIPELINE AND HYDRAULIC GRADIENT - i.e. where pipeline siphoning over Gradient a sewage air release valve positioned on the apex would break the siphon. If positioning on apex is required a modified VENT -O- MAT Series RGX can be supplied.
3. NEGATIVE BREAKS (increase in downward slope or decrease in upward slope).
4. LONG HORIZONTAL SECTIONS - every 600 meters (1/3 of a mile) maximum.
5. LONG ASCENDING SECTIONS - every 600 meters (1/3 of a mile) maximum.
6. LONG DESCENDING SECTIONS - every 600 meters (1/3 of a mile) maximum.
7. PUMP DISCHARGE (not shown in diagram) - just subsequent to non return valve.
8. BLANK ENDS (not shown in diagram) - where a pipeline is terminated by a blind flange or a valve.

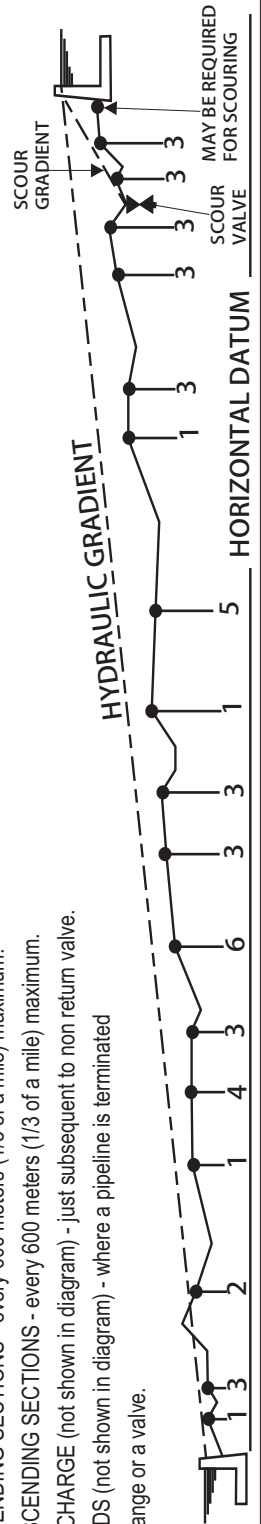

## SELECTION & POSITIONING

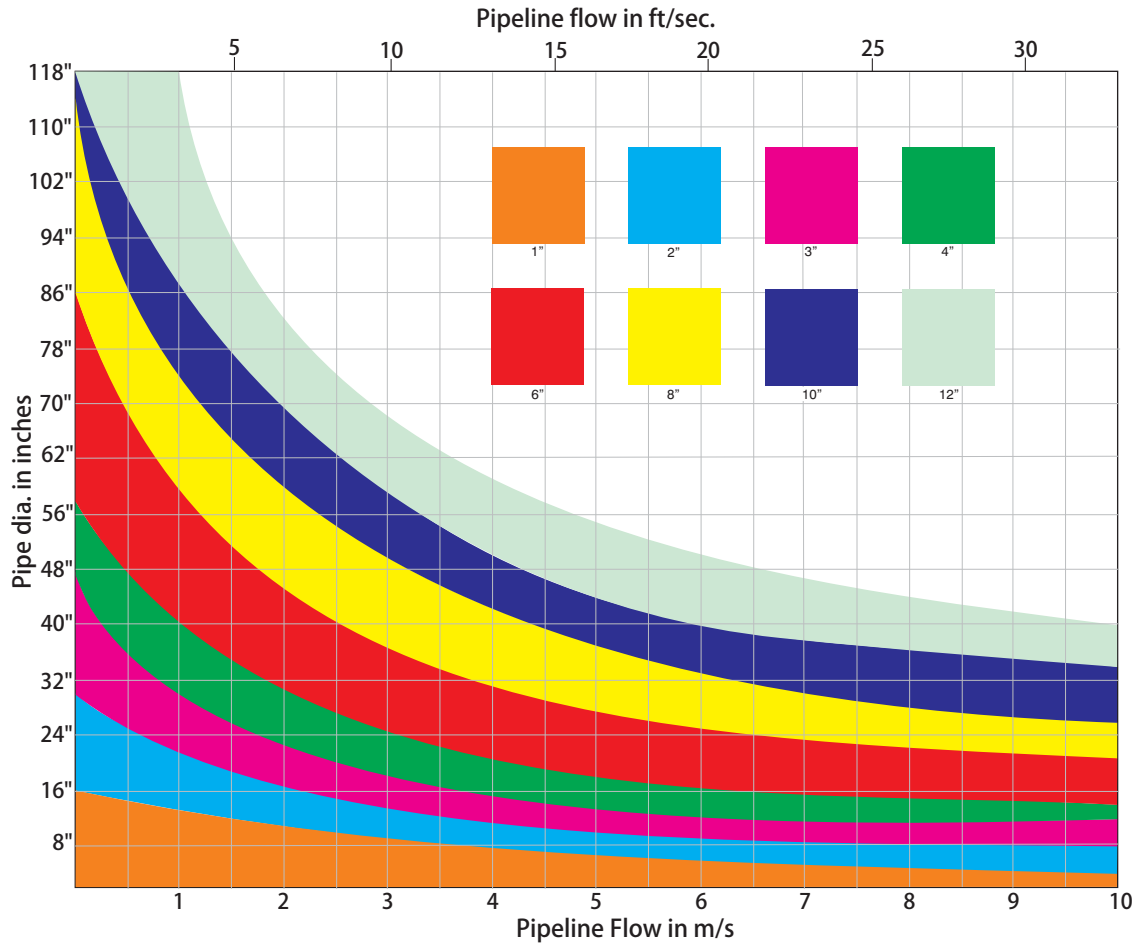

Pipe Dia Inches	Pipeline Velocity in Feet per sec																																
	2	3	5	7	8	10	11	13	15	16	18	20	21	23	25	26	28	30	31	33													
4	78	117	196	274	313	391	431	509	587	626	705	783	822	900	979	1018	1096	1174	1214	1292													
6	176	264	440	617	705	881	969	1145	1321	1409	1585	1762	1850	2026	2202	2290	2466	2642	2731	2907													
8	313	470	783	1096	1253	1566	1722	2036	2349	2505	2819	3132	3288	3602	3915	4071	4385	4698	4854	5167													
10	489	734	1223	1713	1957	2447	2691	3181	3670	3915	4404	4893	5138	5627	6117	6361	6851	7340	7585	8074													
12	705	1057	1762	2466	2819	3523	3876	4580	5285	5637	6342	7047	7399	8104	8808	9161	9865	10570	10922	11627													
14	959	1439	2398	3357	3836	4796	5275	6234	7193	7673	8632	9591	10071	11030	11989	12469	13428	14387	14866	15825													
16	1253	1879	3132	4385	5011	6264	6890	8143	9395	10022	11275	12527	13154	14406	15659	16285	17538	18791	19417	20670													
18	1585	2378	3964	5549	6342	7927	8720	10306	11891	12684	14269	15855	16648	18233	19818	20611	22196	23782	24575	26160													
20	1957	2936	4893	6851	7830	9787	10766	12723	14680	15659	17616	19574	20552	22510	24467	25446	27403	29361	30339	32297													
22	2368	3553	5921	8289	9474	11842	13026	15395	17763	18947	21316	23684	24868	27237	29605	30790	33158	35526	36711	39079													
24	2819	4228	7047	9865	11275	14093	15502	18321	21140	22549	25368	28186	29596	32414	35233	36642	39461	42279	43689	46507													
26	3308	4962	8270	11578	13232	16540	18194	21502	24810	26464	29772	33080	34734	38042	41350	43004	46312	49620	51274	54582													
28	3836	5755	9591	13428	15346	19182	21101	24937	28773	30692	34528	38365	40283	44119	47956	49874	53710	57547	59465	63302													
30	4404	6606	11010	15414	17616	22021	24223	28627	33031	35233	39637	44041	46243	50647	55051	57253	61657	66062	68264	72668													
32	5011	7516	12527	17538	20044	25054	27560	32571	37582	40087	45098	50109	52614	57625	62636	65142	70152	75163	77669	82680													
34	5657	8485	14142	19799	22627	28284	31113	36769	42426	45255	50911	56568	59397	65053	70710	73539	79196	84852	87681	93338													
36	6342	9513	15855	22197	25368	31710	34880	41222	47564	50735	57077	63419	66590	72932	79274	82445	88787	95129	98300	104641													
38	7066	10599	17665	24731	28265	35331	38864	45930	52996	56259	63325	70391	73654	80720	86983	90246	96509	102772	106035	112298													
40	7830	11744	19574	27403	31318	39148	43062	50892	58721	62636	70466	78295	82210	90039	97869	101784	109613	117443	121357	129187													
44	9474	14211	23684	33158	37895	47369	52105	61579	71053	75790	85263	94737	99474	108948	118421	123158	132632	142106	146843	156316													
48	11275	16912	28186	39461	45098	56373	62010	73284	84559	90196	101471	112745	118382	129657	140931	146569	157843	169118	174755	186029													
52	13232	19848	33080	46312	52928	66159	72775	86007	99239	105855	119087	132319	138935	152167	165399	172014	185246	198478	205094	218326													
56	15346	23019	38365	53710	61383	76729	84402	99748	115094	122767	138113	153458	161131	176477	191823	199496	214842	230188	237861	253206													
60	17616	26425	44041	61657	70466	88082	98990	114507	132123	141031	158548	176164	184972	202589	220205	229313	246930	264546	273054	290671													
62	18810	28216	47026	65836	75242	94052	103457	122268	141078	150483	169294	188104	197509	216320	235130	244535	263346	282156	291561	310372													
66	21316	31674	53290	74605	85263	106579	117237	138553	159869	170527	191843	213159	223816	245132	266448	277105	298421	319737	330396	351712													
70	23978	35867	59845	83823	95912	119889	131878	155856	179834	191823	215801	239779	251768	275746	299724	311713	335690	359668	371657	395635													
74	26797	40195	66991	93788	107186	133983	147381	174177	200974	214372	241169	267966	281363	308160	334956	348355	375151	401948	415346	442142													
78	29772	44658	74429	104201	119087	148859	163745	191516	223288	238174	267946	297717	312603	342375	372147	387032	416804	446576	461462	491234													
82	32904	49355	82559	115162	131614	164518	180999	213873	246777	262328	296132	329935	345487	378391	411294	427746	460649	493553	510005	542908													
86	36192	54288	90480	126672	144768	180960	199056	235248	271439	289535	325727	361919	380015	416207	452399	470495	506687	542879	560975	597167													
90	39637	59455	99092	138729	158548	198185	218003	257640	297277	317095	363732	396369	416188	455825	495461	515280	554917	594554	614372	654009													
94	43238	64858	108096	151335	172954	216192	237812	281050	324289	345908	391446	432385	454004	497243	540481	562100	605339	648577	670197	713435													
98	46997	70495	117492	164488	187987	234983	258482	305478	352475	375973	422970	469967	493465	540462	587458	610957	657953	704950	728448	775445													
102	50911	76367	127279	178190	203646	254557	280013	330924	377821	402219	458203	509114	534570	585481	636393	661848	712760	763671	789127	840038													
106	54983	82474	137457	192440	219931	274914	302405	357388	412371	439862	494845	549828	577319	632302	687285	714776	769759	824742	852233	907216													
110	59211	88816	148027	207237	236843	296654	325659	384870	444080	473686	532896	592107	621712	680923	740134	769739	828950	888161	917766	976977													
114	63595	95393	158988	222583	254381	317976	349774	413369	476964	506762	572357	635952	667750	731345	794940	826738	890333	953928	985726	1049321													
118	68136	102205	170341	238477	272545	340682	374750	442886	511023	545091	613227	681363	715432	783568	851704	885773	953909	1022045	1056113	1124250													

Conversion Table ft/sec of Pipeline Velocity to gal/min

## **SURGE & WATERHAMMER PROTECTION**

### Introduction

The Vent-O-Mat Series RGXII "Anti-Surge" sewage air release and vacuum break valve, is an evolution of market feedback and the incorporation of the already proven Vent-O-Mat technology which itself resulted from years of extensive research. The valve unlike many others is not just an adaption of an air valve to handle sewage valve but the result of over 30 years of dealing with sewage and seeing what works and adapting it to the needs of the end user.

### Surge Protection - Initial Filling

The RGXII is always biased in the "Anti-Surge" mode meaning all air release is controlled through the "Anti-Surge" Orifice which is aerodynamically engineered to throttle air discharge when liquid approach velocity would otherwise become too great and induce an unacceptable pressure rise. The air throttling action increases resistance to the flow of the approaching liquid which consequently decelerates to a velocity which reduces the pressure rise when the valve closes (see operation of valve on pages 3). Vent-O-Mat series RGXII is an essential precaution for pipeline priming.

### Surge Protection - Pump Trip Conditions

In instances where a pipeline experiences liquid column separation due to pump stoppage, high shock pressures can be generated when the separated liquid column rejoins.

The Vent-O-Mat series RGXII takes in air through the unobstructed large orifice when liquid column separation occurs, but controls the discharge of air/gas through the "Anti-Surge" Orifice as the separated column commences to rejoin. The rejoining impact velocity is thereby considerably reduced to alleviate high surge pressures in the system (see operation of valve on pages 3).

Other surge control measures may, dependant on pipeline profile, diameter and operating conditions, be needed to provide the primary surge alleviation function with the Vent-O-Mat sewage air-valves forming an integral and valuable addition in a combined strategy for further reducing surge pressures. The benefit of the "Anti-Surge" Orifice can be readily demonstrated by suitable surge modelling software.

### Surge Protection - Pipeline Operating

The operation of valves and similar flow control devices can cause high-pressure transients in an operating pipeline.

The unique, single chamber design of the Vent-O-Mat series RGXII valve enables a pocket of air to be trapped in the valve chamber. Automatic operation of the small orifice control float regulates the volume of air entrapped.

The volume maintained in the valve will provide a cushioning benefit to the pipeline for short duration transient pressure "spikes". This effect can be modelled by the design engineer using suitable surge software.

### Computer Modelling

The effectiveness of Vent-O-Mat "Anti-Surge" technology has been substantiated by independent third party testing and by thousands of applications globally. Effective computer modelling, based on practical tests, has been ensured in the well-known and respected commercially available surge analysis software programmes such as AFT impulse, FLOWMASTER, WATHAM and SURGE 2000.

### Technical and Financial Benefits

1. Improved alleviation of surge pressure magnitudes by slowing surge velocities
  - Surge pressure magnitudes by slowing surge velocities
  - Duration of oscillation following a pump trip, as the sewage air-valve continuously absorbs and dissipates the energies of the surge.
2. Potential for reduction in size and/or quantity of conventional surge protection devices such as surge vessels etc.
3. Automatic protection during initial filling when most surge protection devices are not operational.
4. Holistic protection as each sewage air valve installed has design features to automatically damp surges.
5. The valve is virtually maintenance free.

## PURCHASE SPECIFICATION

VENT -O- MAT MODEL NO.  
Page 5 - Series RGXII

### CONSTRUCTION & DESIGN

The Sewage Air Release & Vacuum Break Valve shall consist of a ductile iron or stainless steel body, Stainless steel direct acting float and solid large orifice and "Anti-Surge" floats in H.D.P.E. - stainless steel nozzle and Stainless steel top cap and EPDM rubber seals and seat.

The valve shall have an integral "Anti-Surge" Orifice mechanism which shall limit transient pressure rise or shock induced by closure to less than 1.5 x valve rated working pressure, however, must open to the full diameter of the valve size during a negative pressure.

The intake orifice area shall be equal to the nominal size of the valve i.e., a 150mm (6") valve shall have a 150mm (6") intake orifice. Large orifice sealing shall be effected by the flat face of the control float seating against a EPDM rubber 'O' ring housed in a dovetail groove circumferentially surrounding the orifice.

Discharge of pressurized air shall be controlled by the seating & unseating of a small orifice nozzle on a EPDM rubber seal affixed into the control float. The nozzle shall have a flat seating land surrounding the orifice so that damage to the rubber seal is prevented.

The valve construction shall be proportioned with regard to material strength characteristics, so that deformation, leaking or damage of any kind does not occur by submission to 1.5 times the designed working pressure. Connection to the valve inlet shall be facilitated by flanged ends conforming to PN10/16, ratings of BS EN 1092 or SABS 1123 Standards or ANSI B16.5 Class 150. AS 4087 Fig. B7, AS 2129 Table E. Flanged ends shall be supplied drilled to the Specified Standard.

### OPERATION

1. Prior to the ingress of liquid into the valve chamber, as when the pipeline is being filled, valves shall vent through the "Anti-Surge" orifice at all times.
2. Valves shall not exhibit leaks or weeping of liquid past the large orifice seal at operating pressures of 0,5 bar (7.2 psi) to 1.5 x valve rated working pressure.
3. When pipeline is fully charged valves shall respond to the presence of air/gas by discharging it through the small orifice at any pressures within a specified design range, i.e. 0,5 bar (7.2 psi) to 16 bar (232 psi) and shall remain leak tight in the absence of air.
4. Valves shall react immediately to pipeline drainage or liquid column separation by the full opening of the large orifice so as to allow unobstructed air intake at the lowest possible negative internal pipeline pressure.



### ORDERING GUIDE

**VALVE SIZE:**

- DN50 (2") -
- DN80 (3") -
- DN100 (4") -
- DN150 (6") -
- DN200 (8") -

**VALVE SERIES No.**

**VALVE TYPE:**  
DOUBLE ACTING

**VALVE END CONNECTION:**

- STUDED FLANGED - BS4504 or SABS 1123
- THREADED - BSP MALE
- THREADED - NPT MALE
- STUDED FLANGED - ANSI B16.5

**VALVE PRESSURE RATING:**

- PN10 (145 psi)
- PN16 (232 psi)

**Note:**

1. DN250 (10") and DN300 (12") valves are available on request.

### TEST SPECIFICATION

All air release valves supplied shall be subjected to the following testing procedures in the order laid down:  
 (A) A high pressure strength and leak test whereby the valve is filled with water and pressurized to twice the rated working pressure which shall be held for a period of 2 minutes. Any leaking, weeping or sweating shall be reason for rejection.

(B) A low head leak test whereby the valve is filled with water and pressurized to a maximum of 0.5 bar (7.2 psi) using a visible water column connected to the test rig. The valve shall be rejected if leak tightness is not maintained for 2 minutes.

(C) Every tenth air release valve of the same size and pressure rating must be subjected to a small orifice function test "DROP TEST" - whereby the valve is filled with water, pressurized to above rated working pressure and isolated from the test rig by closure of an isolating valve. A chamber in the test rig immediately prior to the isolating valve must be filled with compressed air at a pressure equal to that being maintained in the air release valve. The isolating valve is then opened so as to allow the air to rise in the air release valve without the pressure dropping lower than 2 - 3 bar (29 - 44 psi) above rated working pressure of the air release valve. The "DROP TEST" is then carried out by slowly bleeding off the pressure through a suitable cock until rated working pressure is reached and the float drops away from the orifice to allow discharge. Failure of the air release valve to function in the manner described will be reason for rejection.

On request the manufacturer shall provide batch certificates of test compliance which shall be cross referenced to serial numbers indelibly marked onto the identity label of each valve.

**IMPORTANT NOTE:** It is impossible to inject air into an incompressible liquid, air injection can only be achieved if the liquid can be displaced which implies that the pressure in the test rig must be reduced to atmospheric, and absolutely nothing is proven by discharge through the small orifice of the air release valve at atmospheric pressure. "DROP TESTING" in this manner is not acceptable.

**Copy and Complete the Form Below For Any Additional Information and E-mail, Fax or Mail to:**

Aveng DFC  
P O Box 5064  
Benoni South, 1502  
Phone: +27 11 748 0200 • Fax: +27 11 421 2749

E-mail: [dfc@dfc.co.za](mailto:dfc@dfc.co.za)

Or contact us via our Website  
[www.ventomat.com](http://www.ventomat.com)

**Company Name:** .....

**Postal Address:** .....

**Postal Code:** ..... **Country:** .....

**Tel:** ..... **Fax:** ..... **Email:** .....

**Contact Name:** ..... **Title:** .....

**Comments:**

.....  
.....

## Products you are interested in:

**VENT-O-MAT® Series RBXc Air Release & Vacuum Break Valves**

Compact single chamber design with integral "Anti-Shock" surge dampening mechanism in an economical cast ductile iron construction

**VENT-O-MAT® Series RBX Air Release & Vacuum Break Valves**

Compact stainless steel single chamber design with integral "Anti-Shock" surge dampening mechanism

**VENT-O-MAT® Series RGX Series Air Release & Vacuum Break Valves**

Compact stainless steel or ductile iron single chamber design with integral "Anti-Shock" surge dampening mechanism for sewage applications

**VENT-O-MAT® Series RPS Air Release & Vacuum Break Valves**

Glass reinforced polypropylene CATT air valve for industrial, irrigation and small reticulation systems

## GENERAL CONDITIONS OF TENDER AND SALE

### 1. DEFINITIONS

- 1.1 Seller:  
Dynamic Fluid Control (Ply) Ltd
- 1.2 Purchaser:  
The party who places an order on the Seller, which is accepted by the Seller in terms of Clause 2. (such acceptance hereinafter being referred to as "Acceptance of Order").
- 1.3 Goods  
The materials, products and or services ordered by the Purchaser and accepted by the Seller in terms of Clause 2, Contract.
- These General Conditions of Tender and Sale, technical specifications of the Purchaser's order as have been specifically agreed in writing and the Acceptance of Order, together with only such other terms and conditions as may be specifically agreed in writing between the parties.

### 2. ACCEPTANCE OF ORDER

- 2.1 The Purchaser's order shall constitute an offer, and a contract shall only come into existence when the Seller accepts the Purchaser's order, by issuing an Acceptance of Order or by performing in response to the Order. Unless otherwise specifically agreed in writing in the contract any other terms and conditions including those forming part of the Purchaser's order, which deviate from the General Conditions, shall not form part of the Contract, and shall be of no force or effect.
- 2.2 In the event that the Purchaser and the Seller engage in negotiations over amendments or additions to or deletions from the General Conditions of Tender and Sale. these General Conditions shall govern the sale of the goods until such negotiations are finalised and these General Conditions amended (if at all) by agreement in writing.

### 3. SCOPE OF CONTRACT

The Seller's obligations in terms of the Contract will be to produce the Goods in accordance with such designs, instructions, itemised details, plans, drawings, programmes and specifications (the specifications) as form part of the Contract, and in particular the Seller will not be responsible for the adequacy of or for any costs occasioned by the inadequacy of any such specifications or for any foundations or supporting structures of other work as may have been provided, prepared or specified by or on behalf of the Purchaser.

### 4. LIABILITY

- 4.1 Liability for Defects  
The Seller undertakes that the Goods will conform to such specifications in respect of each other as have been specifically accepted by the Seller in writing and in the event of the Goods proving not to be in accordance with such specifications, the Seller shall, if requested to do so in writing within a reasonable time of discovery of such failure to conform to such specifications (hereinafter referred to as defects), but not in any event after 6 months have elapsed from the date of delivery of such defective Goods to the Purchaser, at its option, repair or replace the defective portions/components of the Goods, by supplying the repaired or replacement portion components of the Goods to the initial place of delivery, or at the further option of the Seller, to credit the Purchaser with the invoice value of the defective portion/components of the Goods in question. Notwithstanding anything to the contrary anywhere contained, the Seller shall have no liability in respect of any defects in the Goods, whether latent or patent, not notified to the Seller in writing before the end of the aforesaid 6 month period.
- 4.2 Liability for Delay  
Subject to the provisions of Clause 8 and 10, the Seller undertakes to supply the Goods in accordance with such delivery dates as are specifically agreed in contract, and in the event that the Goods are not supplied in accordance with such dates, or within extensions or revisions of such dates, or if delays caused by the discovery of defects after delivery, the Seller's liability shall be limited to such penalty for late delivery as may have been specifically accepted by the Seller in writing in respect of each order accepted by the Seller. Such penalty shall only be payable in the event that, and to the extent that, the Purchaser is himself legally obliged to pay penalties in respect of each delay and in no event shall such penalty exceed 10% of the unescalated Contract Price of such portions of the Goods as cannot, because of the delay, be put to the use intended, and such penalty shall constitute the Seller's sole liability and the Purchaser's sole remedy for such delay. Notwithstanding anything to the contrary anywhere contained, the liability of the Seller howsoever arising out of the Contract or in Delict or by operation of statute shall not extend beyond the obligations specifically assumed in terms of this Clause 4, and the Seller.
- 4.3.1 gives no other warranties, expressed or implied in respect of (without limitation) workmanship, materials, fitness for purpose, merchantability or products liability not set out herein;
- 4.3.2 in respect of "brought out" or proprietary items not of its own manufacture, gives no greater warranty and accepts no greater liability than that given or accepted by and enforceable against the supplier/manufacturer thereof.
- 4.3.3 gives no warranties in respect of Goods used other than for the intended purpose, or for defects arising through fair wear and tear or neglect, shall in no event be liable for the Purchaser's loss of profits, loss of use, loss of production, loss of custom or goodwill, or for any special, indirect or consequential damages howsoever arising.

### 5. DELIVERY

- 5.1 Unless otherwise stipulated in the Contract, delivery shall be "ex Seller's works" and the Contract Price is based on such "ex works" delivery and is exclusive of any sales tax payable in terms of any applicable statute, packaging, freight and insurance during transport.
- 5.2 The risk in and to the Goods will pass to the Purchaser on Delivery and claims for non delivery or for shortages or damage upon receipt of the Goods must be made in writing by the Purchaser within the earlier of 7 (seven) days of the relevant consignment note or receipt of the Goods as the case may be, failing which the Seller shall have no liability in respect of such claims.
- Should the Purchaser fail or refuse to take delivery of the Goods when delivery is tendered by the Seller, the Purchaser shall be liable for such costs as may be incurred by the Seller as consequence thereof.

### 6. Contract Price

- Unless otherwise specifically agreed in writing in each particular instance:
- 6.1 the contract price to be paid by the Purchaser for the Goods shall be as set out in the tender and is based on the costs of materials, transport, labour, insurance rates, exchange rates and import duties ruling at the date of the tender and any variation in such costs or rates occurring between the date of the tender and the date of payment, shall be for the account of the Purchaser, and shall be determined in accordance with the formula included in the Contract, and if no formula is so included, in accordance with the prevailing relevant formulae, principles and indices published by SEIFSA.
- 6.2 If the Goods or any parts thereof are to be imported, the price will be based on the rates of exchange, freight, insurance premiums, lighterage, landing charges, port dues, custom duty and railage at the date of tender, or as specifically agreed. Should these rates vary between the date of the tender and the date upon which charges are incurred, the price shall be varied by the amount of the increase or decrease in such charges.

- 6.3 the Contract Price shall be paid in cash, free of exchange, deduction or set off within 30 (thirty) days of the date of Seller's statement, provided that in any event, notwithstanding delivery of the Goods to the Purchaser or to any third party, it is specifically agreed that it is the intention of the parties that the Goods shall not accede to any other property, whether moveable or immovable, and that it is as far as any other goods or equipment are concerned the Goods shall, for the purposes of accession be deemed to be the Principle items, and that ownership of the goods and any items accessory thereto shall at all times remain vested in the Seller, and shall not pass to the Purchaser until the full Contract Price has been paid. In the event of non-payment, the Purchaser hereby irrevocably authorises the Seller or its duly authorised agents to repossess the Goods wheresoever they may be found, and further, at its option, in detach or unmix by itself, its agents or servants, the Goods from anything to which they are attached or in which they are installed or annexed without being responsible for any damage that may be caused thereby and may, for such purpose, by itself, its servants or agents, enter upon any land or building, vehicle or vessel or other place upon which the Goods are reasonably thought to be situated.

- 6.4 Payments delayed after the due date for payment shall be subject to interest charges, compounded monthly with effect from the date of delivery, at prime bank overdraft rate.

- 6.5 Where payment by the Purchaser is effected by cheque, and where the post is used the risk of loss arising from the use of a cheque or the use of the post, shall rest with the Purchaser.

### 7. RENUNCIATION OF BENEFITS

The Purchaser hereby renounces the benefits of any other rights; not expressly referred to in these General Conditions are not expressly agreed in writing and to which it may be entitled, or which it may acquire in terms of the Agricultural Credit Act, 28 of 1966 as amended, the Moratorium Act. 25 of 1963 or any other similar rights under any other statute.

### 8. VARIATIONS

The Seller shall supply the Goods strictly in accordance with the Contract. Should the Purchaser require variations to the Goods, or to the quantities thereof, or should the Seller be hindered, delayed or prevented from supplying in terms of the Contract or be exposed to extra cost owing to extensions or to emissions from the order, deviations from the specifications, late, defective or non-receipt of information or rep issue materials or by any other act, default or omission by or on behalf of the Purchaser, the Seller shall be entitled to an appropriate variation to the rates or to the Contract Price or to the programme, or any other obligation of the Seller, provided that no such variation required by the Purchaser shall, without the written consent of the Seller, together with such other variations as may have been requested, involve a variation of more than 10% (ten per centum) to the Contract Price or to the quantities set out in the Contract.

### 9. RETURNS

Returns, if accepted by the Seller at its sole discretion and upon such terms as it may prescribe, shall be credited Subject to a deduction of a minimum of 10% (ten per centum) as a handling charge, subject to the goods being within their specified shelf life and in a marketable condition and provided further that the Purchaser shall be liable for all costs of delivery to the Seller's designated premises.

### 10. FORCE MAJEURE

- 10.1 Neither party shall be liable to the other for inability to perform or delayed performances in terms of the Contract, should such inability delay arise from any cause beyond the reasonable control of such party, the existence or happening of which cause has been drawn to the attention of the other party within a reasonable time of the occurrence of such cause (hereinafter referred to as "a Force Majeure event").
- 10.2 For the purposes of this clause a Force Majeure event shall, without limitation to the generality of (the foregoing, be defined to include, strikes, lock outs, labour disputes, accidents, plant and machinery breakdowns, fire, explosions, theft, war (whether declared or not) invasion, acts of foreign enemies, hostilities, riot, civil insurrection, flood, earthquake, lightning, act of local or national government, martial law, failure or delay of, or the part of the Seller's supplier(s) of service, of "bought out" or raw materials, to meet delivery dates, or any failure or delay on the part of the Purchaser or the Purchaser's agents or other Contractors to provide the Seller with free issue materials, specifications, or defects or changes in such Specifications, or any other cause beyond the reasonable control of the party effected.

### 11. PATENTS COPYRIGHT AND CONFIDENTIALITY

- 11.1 The Purchaser shall indemnify and hold harmless the Seller against all claims and expenses of whatsoever nature and description arising from alleged or infringement of any Letters Patent, Trade Mark, Designs or Copyright occasioned by the Seller's performance of this Contract.
- 11.2 The Seller warrants however that any designs specified by it shall not infringe any of such Letters Patent, Trade Marks, Designs or Copyright.
- 11.3 The Purchaser shall keep confidential and shall not use for any purpose other than the Contract itself, all drawings and designs supplied by the Seller in terms of the Contract, and the Purchaser shall indemnify the Seller against any loss suffered by the Seller as a result of the breach of this clause. Such drawings and designs supplied by the Seller remains the exclusive property of the Seller and shall be promptly delivered and returned to the Company upon completion of the Contract.

### 12. BREACH

Should either party be in breach of any material obligations imposed in terms of the Contract and fail to remedy such breach or take positive steps towards remedying such breach within 14 (fourteen) days of written notice of such breach from the other party, then the non defaulting party shall be entitled to cancel the Contract, without prejudice to such other rights that such non defaulting party may have in terms of this agreement or at law.

### 13. GOVERNING LAW AND DISPUTES

- 13.1 The Contract shall be construed and interpreted in accordance with, the laws of the Republic of South Africa.
- 13.2 Any disputes arising between the parties in respect of the Contract shall, at the option of the Seller, be justiciable in the Magistrates Court of South Africa having jurisdiction over the Purchaser, notwithstanding the fact that the dispute might otherwise have fallen outside the jurisdiction of such Magistrates Court and the Purchaser to such jurisdiction.

### 14. FUTURE CONTRACTS

These General Conditions of Tender and Sale (as they may be amended from time to time by the Seller shall also apply to any future, oral or written contract for the supply of goods and/or services by the Seller to the Purchaser, save to the extent that such conditions are in any future contracts specifically varied or excluded or are inconsistent with what is expressly agreed in any such future contract.

### 15. LANGUAGE

These General Conditions of Tender and Sale are available in the other official language, upon request.

**DFC** **DYNAMIC**  
**FLUID CONTROL**

**Aveng DFC  
P O Box 5064  
Benoni South  
1502  
South Africa**

**Tel:- 27 11 748 0200  
Fax:- 27 11 421 2749**

**dfc@dfc.co.za  
www.ventomat.com**



***Revision Date Sept 2015 Catalogue RGXII 0003***