



Truscan Measuring System

Users Manual



TABLE OF CONTENTS

I.	INTRODUCTION	1
	TRUSCAN LIMITED WARRANTY AGREEMENT	3
	GENERAL OVERVIEW	4
	About This Manual	4
	Training	4
	VARIANCES: GRAPHICS / SPECIFICATIONS	5
	Specifications Versus Vehicle Measurements	5
	GENERAL SAFETY INFORMATION	6
	Controls	6
	Laser Safety Information	6
	Federal Communications Commission	8
	COPYRIGHT INFORMATION	8
	Truscan Users Manual	8
	Truscan Software	8
	Truscan ASSISTANCE	8
II.	TRUSCAN HARDWARE	9
	COMPONENT TERMINOLOGY	9
	COMPONENT OVERVIEWS	10
	Workstation	10
	Cabinet Assembly	11
	Body Scanner and Tray	16
	Targets	16
	Target Base	16
	Attachments / Clips	17
	Bolt Attachments	18
	Hole Attachments	18
	Optional Attachments	19
	Optional Magnetic Attachments	19
	Optional Target Extension Rods	20
	Optional Truck Attachment Package	20
	Optional Upper Body Bar Assembly	21
	Spacers and 3 Inch Bolts	23
	Chief Specifications Data	23
	Literature	23
	Diskettes and CDs	23
	COMPONENT MAINTENANCE	18
	COMPONENT TROUBLESHOOTING	24
III.	TRUSCAN Galileo Plate Retrofit Kit (CK140036) Installation Instructions	25
IV.	Vector Galileo Back Panel Retrofit Kit (CK140020) Installation Instructions	27
V.	Galileo Verification Instructions	34
VI.	Initial Setup: Connecting A Scanner To Genesis Application	41
VII	Reconnecting A Scanner To Genesis Scanner	46
VIII.	Replacement Battery (CK720341) Installation and Removal Instructions	48
IX.	How to Retrieve Troubleshooting Information	51

TRUSCAN MEASURING SYSTEM LIMITED WARRANTY AGREEMENT

Chief Automotive Technologies, Inc. warrants for one year from date of purchase any components of its Truscan Measuring System and 24 months for its Truscan Scanner which do not perform satisfactorily due to defect caused by faulty material or workmanship. THE WARRANTY DESCRIBED HEREIN SHALL BE IN LIEU OF ANY OTHER WARRANTY, EXPRESS OR IMPLIED, INCLUDING BUT NOT LIMITED TO, ANY IMPLIED WARRANTY OF MERCHANTABILITY, OF FITNESS FOR A PARTICULAR PURPOSE, OF TITLE, OR OTHERWISE ON THE PART OF CHIEF AUTOMOTIVE TECHNOLOGIES, THE EQUIPMENT, THE SPECIFICATIONS CONTAINED THEREIN OR ANY UNIT THEREOF. Chief's obligation under this warranty is limited to the repair or replacement of components which are defective and which have not been misused, carelessly handled, or defaced by the repair or repairs made or attempted by others. Chief Automotive Technologies does not assume responsibility for any injury or property damage resulting from the operator's misuse of this product. Unless a statement made by any representative of Chief Automotive Technologies is identified as a warranty, any such statements shall not be construed to constitute warranties and do not form part of the basis of the bargain; it being expressly understood that such statements are merely made in the course of the negotiations of the parties. FURTHERMORE, Chief Automotive Technologies specifically excludes or disclaims any warranty, express or implied, based on any sample or model shown by Chief Automotive Technologies to the buyer for demonstration purposes only.

LIMITATION OF REMEDIES. The parties agree that the buyer's sole and exclusive remedy against Chief Automotive Technologies shall be for the repair or replacement of components which are defective and which have not been misused, carelessly handled, or defaced by the repair or repairs made or attempted by others. The buyer agrees that no other remedy (including, but not limited to, incidental or consequential damages for lost profits, lost sales, injury to person or property, or any other incidental or consequential loss) shall be available to him. This exclusive remedy shall not be deemed as to have failed of its essential purpose so long as Chief Automotive Technologies is willing and able to repair or replace defective parts in the prescribed manner.

Prior to the return of any merchandise for a warranty claim, contact the Customer Service Department (800-445-9262) for a Returned Goods Authorization Number and instructions. No goods may be returned without a Returned Goods Authorization Number.

The buyer shall be required to deliver the defective part to Chief Automotive Technologies UNLESS (1) the part was destroyed as a result of its defect or of any defect in any part covered in this warranty, AND (2) Chief is reasonably satisfied that the part was defective at the time of its failure.

DISCLAIMER OF WARRANTY

THE GRAPHICS AND DATA SUPPLIED WITH THE Truscan MEASURING SYSTEM HAVE BEEN COMPILED FROM AUTHORITATIVE SOURCES. EVERY EFFORT HAS BEEN MADE BY CHIEF AUTOMOTIVE TECHNOLOGIES, TO ASSURE ACCURACY; HOWEVER, MANUFACTURING CHANGES, ERRORS OR OMISSIONS MIGHT OCCUR. CHIEF AUTOMOTIVE TECHNOLOGIES DOES NOT ASSUME RESPONSIBILITY NOR CAN IT BE HELD RESPONSIBLE FOR THE LOSS OR DAMAGE RESULTING FROM VEHICLE MANUFACTURER'S CHANGES, ERRORS, OR OMISSIONS IN THIS SYSTEM.

TRUSCAN MEASURING SYSTEM WARRANTY REGISTRATION FORM		
Please fill out completely and detach from Truscan Measuring System Users Manual. Return form to:		
Chief Automotive Technologies, 996 Industrial Drive Madison, Indiana 47250		
Accepted this	day of	20
Serial Numbers:		
System	Shop Name:	
Body Scanner	Address:	
Computer	City, State, Zip:	
Monitor	By:	
Printer	Title:	

I. INTRODUCTION

GENERAL OVERVIEW

Whether detecting misalignment in a vehicle's structure or verifying repairs have eliminated the damage, the Truscan computerized measuring system can do the job. Truscan integrates the precision of laser scanning with a computerized data base for unmatched accuracy in collision repair and analysis. In addition to showing extent of collision damage, Truscan monitors progress throughout the repair and verifies the vehicle's structure is correctly aligned. Printed reports verify the vehicle's structural condition by showing overhead diagrams that display centerline, datum line and datum height measurements.

The Truscan system measures on the principle of triangulation. The system's electronic Body Scanner houses Laser Lights that reflect off of revolving mirrors toward light-reflective Targets (each bearing a unique code) that are suspended from a vehicle's reference points. The Body Scanner houses photo sensors that identify the angle of revolving laser reflections. This information is transferred to the computer which performs the triangulation and Target identification functions.

About This Manual

This manual provides information on basic hard-ware components. It also provides pertinent information regarding startup/shutdown procedures, examples of on-screen Windows/Dialog Boxes and Vehicle Graphics, Keyboard/Mouse/Pen functions, Special Keys, and information on how to use the Truscan Help Text. Pertinent software functions and parts ordering information appear in the Tutorial and the Truscan Parts Manual.

Chief Automotive reserves the right to alter product specifications and/or package components without notice. Also, components shown in this manual may vary slightly in appearance from those that are actually supplied with the Truscan computerized measuring system.

Training

Chief Automotive Technologies also offers professional training. For maximum productivity and equipment utilization, each person operating a Truscan computerized measuring system should receive training conducted by Chief Training Department personnel. For information about training locations and dates, contact Chief Automotive Technologies, 996 Industrial Drive Madison, Indiana 47250 tel. 800-445-9262 Option 2, Attn: Training Department School Coordinator or contact your local representative.

VARIANCES: GRAPHICS/SPECIFICATIONS

Graphics

The Graphics displayed by the Truscan computerized measuring system are of high quality and have been checked for accuracy, but may not reflect the vehicle's actual appearance in every detail. Variances may exist as a result of changes made by vehicle manufacturers or details omitted as a result of space limitations.

Specifications Versus Vehicle Measurements

A vehicle's final measurements may vary from specifications listed and still be aligned correctly. Variances between vehicle measurements and specifications result from one or a combination of the following conditions:

- Vehicle specifications are compiled from vehicle manufacturer's engineering drawings and/or the measuring of new (undamaged) vehicles.
- Most vehicle manufacturers control only a small number of reference points on vehicle's lower structure. These reference points are commonly referred to as master control points, class one control points, principle locating points, etc. Each of these control points is usually held to a tolerance of plus or minus 3mm in three dimensions (length, width, height). Other reference points have a larger tolerance, but generally, a tolerance of plus or minus 5mm in three dimensions (length, width, height) is considered 'normal' according to Chief Automotive Technologies experience.

In Arrow Display Mode, reference point measurements that exceed tolerance appear in 'red' whereas those falling within tolerance appear in 'blue'.

- Some reference points used for dimensioning the same make and model of vehicle vary from one manufacturing plant to another. Also, periodic manufacturing improvements can affect the location of points used for dimensioning.

Key points to remember when realigning a vehicle:

- Length and width dimensions on each side of vehicle should be within plus or minus 3mm of each other when control or reference points are symmetrical. Frequently, the height at front and rear of vehicle will exceed this tolerance according to Chief Automotive Technologies experience.
- When excessive pressure is needed near end of realignment process, and when area around spot welds begins to deform, stop pulling and reevaluate the repair. This situation usually occurs when a vehicle's components were not placed on specification during manufacture. In this case, continuing to pull in an attempt to achieve an exact specification may actually damage the vehicle.
- When a vehicle's dimensions vary beyond 'normal' tolerances, it is the repair technician's responsibility to determine if dimensional variances will affect suspension and steering alignment, the safe operation and handling of vehicle and alignment of body panels.

GENERAL SAFETY INFORMATION

CAUTION Use of controls or adjustments or performance of procedures other than those specified in this Users Manual may result in hazardous laser radiation exposure. See CAUTIONS on Workstation and Body Scanner. (See illustration below.)

IMPORTANT DO NOT plug the Truscan system into same line as a welder. The built-in surge protector may not be sufficient to protect against current fluctuations that result from welder use, and it may cause the computer to fail. Also, avoid metal-to metal contact between all components (i.e. Workstation, Body Scanner, Welder, Vehicle Platform).

Controls

“On”/“Off” switch on Workstation — Allows power to Computer and other electrical components.

“On”/“Off” switch on Body Scanner — Allows power to Body Scanner including lasers.

Laser Safety Information

Laser Power Output: <5 mw.

Wavelength: 650 - 670 nm.

NOTE: Truscan System is for indoor use only.

NOTE: Properly licensed / certified electrician needed to install the appropriate power cord plug end on main scanner power cord set.

CAUTION Avoid exposure! Laser radiation is emitted from Body Scanner apertures.

BODY SCANNER

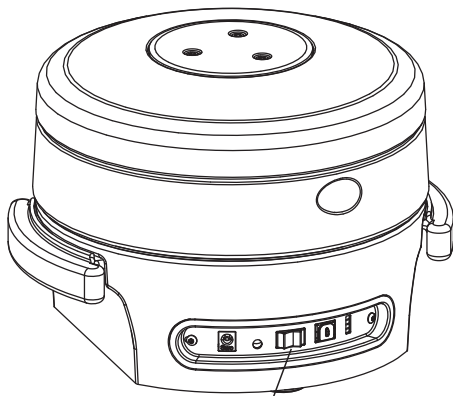

Always Turn Scanner OFF
Before Disconnecting



WORKSTATION







Laser Safety

This is a **Class IIIa/3R (with Class III3b embedded)** laser product which, during normal operation, does not permit human access to laser radiation in excess of Class IIIa/3R established limits. This product complies with 21CFR1040.10/.11 and IEC60825.

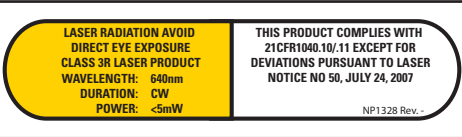
This system is fully interlocked to prevent accidental access to laser radiation. Any attempt to defeat the safety interlock elements of this product is a violation of Safety Standards which this product complies with, and the protection provided by the product may be impaired.

CAUTION Use of controls or adjustments or performance of procedures other than those specified herein may result in hazardous radiation exposure.

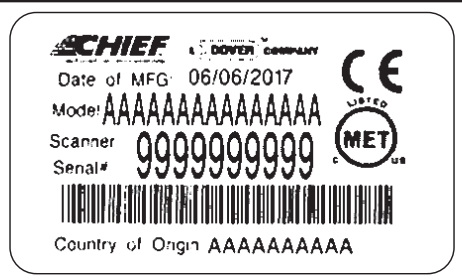
LABEL	NAME	LOCATION
 <p>LASER RADIATION AVOID DIRECT EYE EXPOSURE CLASS 3R LASER PRODUCT WAVELENGTH: 640nm DURATION: CW POWER: <5mW</p> <p>THIS PRODUCT COMPLIES WITH 21CFR1040.10/.11 EXCEPT FOR DEVIATIONS PURSUANT TO LASER NOTICE NO 50, JULY 24, 2007</p> <p>NP1328 Rev. -</p>	<p>Laser Warning Logotype Certification</p>	<p>On Back Panel Near Power</p>
 <p>LASER APERTURE</p> <p>NP1327 Rev. -</p>	<p>Aperture</p>	<p>Top Cover</p>
 <p>CAUTION MISE EN GARDE LASER LE LASER 3R</p> <p>NP1331 Rev. -</p>	<p>3R Caution</p>	<p>On Sides</p>
 <p>CAUTION Laser Radiation When Open Avoid Exposure To Beam</p> <p>NP1332 Rev. -</p>	<p>3B Caution (Internal)</p>	<p>Inside</p>
 <p>CHIEF automotive technologies 996 Industrial Drive Madison, IN 47250 Phone: 800.445.9262 Fax: 866.275.0173 www.chiefautomotive.com</p> <p>NP1329 Rev. -</p>	<p>Manufactures ID</p>	<p>On Bottom</p>
 <p>CHIEF & DOVER COMPANY Date of MFG: 06/06/2017 Mode: AAAAAAAAAAAAAAAAAA Scanner: 9999999999 Serial# 9999999999 Country of Origin AAAAAAAAAA</p> <p>CE MET</p>	<p>Manufactures ID</p>	<p>On Bottom</p>

General Safety Information (continued)

Federal Communications Commission

The Truscan computerized measuring system has been tested and found to comply with: 1) Limits for a Class A digital device, pursuant to Part 15 of the FCC Rules. 2) CE standards for emissions and Immunity (EN61326). These limits are designed to provide reasonable protection against harmful interference when equipment is operated in a commercial environment. This equipment generates, uses, and can radiate radio frequency energy and, if not installed and used in accordance with users and training manuals provided, may cause harmful interference to radio communications. Operation of this equipment in a residential area is likely to cause harmful interference in which case the user will be required to correct the interference at his own expense.

COPYRIGHT INFORMATION

Truscan Users Manual

Chief Automotive Technologies. All Rights Reserved. No part of this work covered by copyrights hereon may be reproduced or copied in any form or by any means including, but not limited to, graphics, electronic, or mechanical, including photocopying, taping, printing or information storage and retrieval systems — without written permission of Chief Automotive Technologies, Madison, Indiana, U.S.A. All inquiries relating to use of this information should be addressed to Chief Automotive Technologies, Tel. 800-445-9262 Option 2, Fax 812-273-7337.

Truscan Software

Chief Automotive Technologies. All Rights Reserved. No part of this work covered by copyrights hereon may be reproduced or copied in any form or by any means including, but not limited to, graphics, electronic, or mechanical, including photocopying, taping, printing or information storage and retrieval systems — without written permission of Chief Automotive Technologies, Madison, Indiana U.S.A. All inquiries relating to use of this information should be addressed to Chief Automotive Technologies, Tel 800-445-9262 Option 2, Fax 812-273-7337.

Truscan ASSISTANCE

Chief Automotive Technologies offers assistance to Truscan program operators. When contacting Chief Automotive Technologies, operators should be prepared to give their name, telephone number (including area code), version of software in use and nature of problem encountered. To identify version of software in use, select 'About' from list of items under Help heading in any Menu Bar. In U.S.A., call toll free 800-445-9262 Option 2. If outside U.S.A., contact an authorized Chief Automotive Technologies representative.

Computer Program Updates

Updates and changes to computer programs will be issued from time to time via computer CDs. Explanations of changes and instructions for installing them will accompany the CDs.

Specification Updates/Corrections

Annually, and as required, updates and additions to vehicle specifications (and instructions for installation) will be made available for purchase.

Keeping Records of Service and Updates

Owners should keep records of services performed and updates provided. These records will be helpful when placing calls to the toll free support number.

II. Truscan HARDWARE

COMPONENT TERMINOLOGY

Equipment in Chief's Truscan Computerized Measuring System (see Figure 1) is easy to use and provides accurate readings. Its basic components include:

- | | |
|-----------------|---------------------------|
| 1. Monitor | 5. Decal, Laser Radiation |
| 2. Keyboard | 6. Targets |
| 3. Workstation | 7. Attachments / Clips |
| 4. Body Scanner | |



CAUTION: Use of controls, adjustments or performance of procedures other than those specified in this manual may result in a breach of warranty and could result in hazardous radiation exposure. See **CAUTIONS** on Workstation and Body Scanner.



Figure 1

COMPONENT OVERVIEWS

Workstation

The Truscan Workstation (see Figure 2 and 2a) is a steel cabinet that houses a Computer, Display Monitor, Keyboard, Printer, Power Supply (+ 18 volt, 3.33 AMP), and assorted Targets, Attachments, Clips and Scales. The cabinet is supported by casters and features a drawer for the Body Scanner when it is not in use. The operating temperature of both the workstation and scanner are between 40°F and 105°F with a maximum relative humidity of 80%. Maximum altitude of 6000 ft.

Truscan computer system features a 500 GB hard drive, a DVD drive, 4 GB of memory, includes keyboard and mouse devices, display monitors, and a printer (see Figure 2 and 2a).

Connect the Truscan to a 110V/60Hz./6 amp. power source or 220V/50Hz./4 amp. power source. See back panel label for the power source configurations you have been provided, Figure 2a. A single purpose line is recommended. Do not use circuits subject to frequent interruptions or outages. Avoid circuits with power surges such as from welders and some power tools. Built-in surge protector may not be sufficient to protect against current fluctuations and it may cause the Truscan computer to fail. Avoid metal-to-metal contact between components (i.e. Workstation, Body Scanner, Welder, Vehicle Platform), and move the Truscan components away from welding areas to avoid damage from sparks.

IMPORTANT Voltage requirements may vary in some countries.

Figure 2

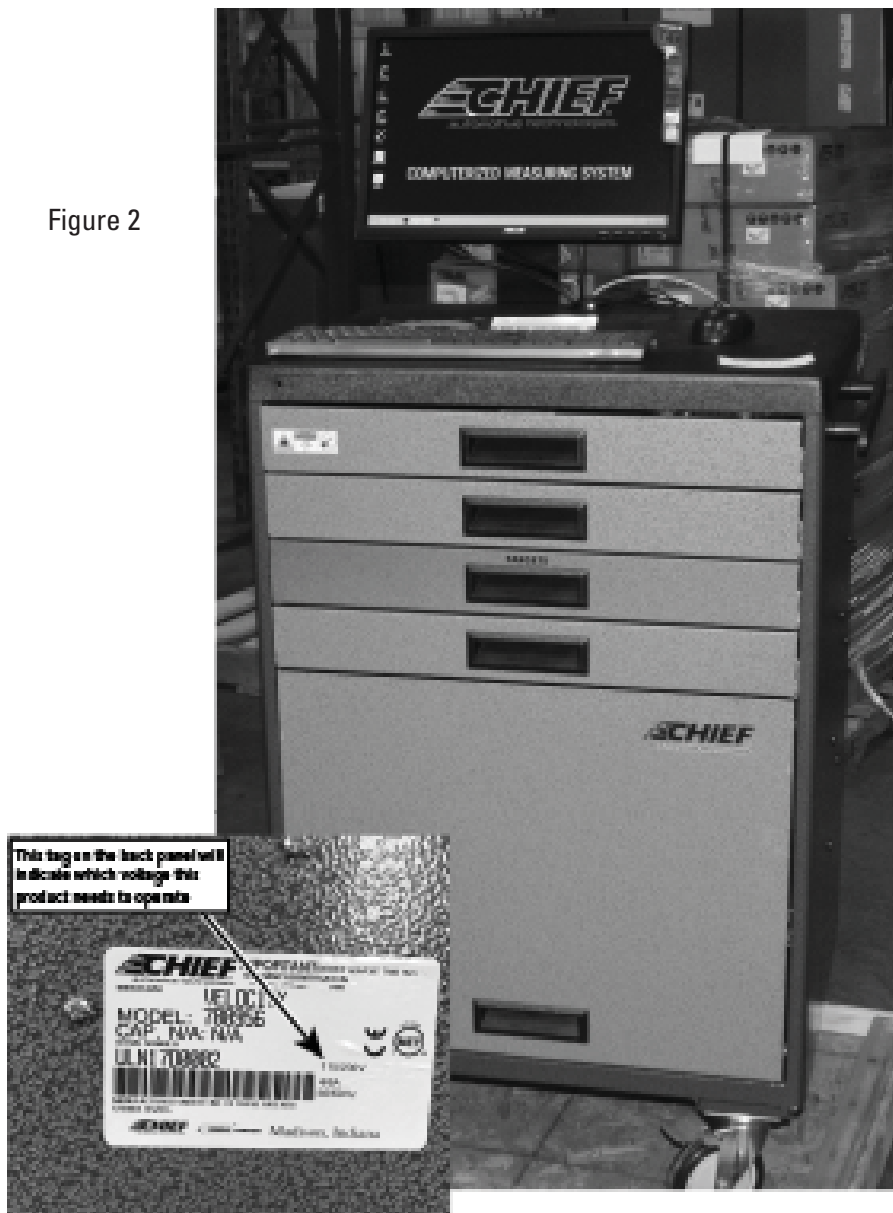

CABINET ASSEMBLY

1. Unpack the cabinet and set the monitor box aside, Figure 3.

2. Locate hook inside cabinet, Figure 4, and assemble to back of cabinet as shown, Figure 5.

Figure 4

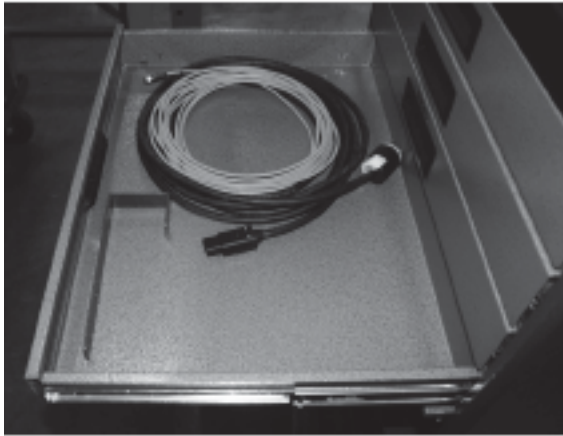
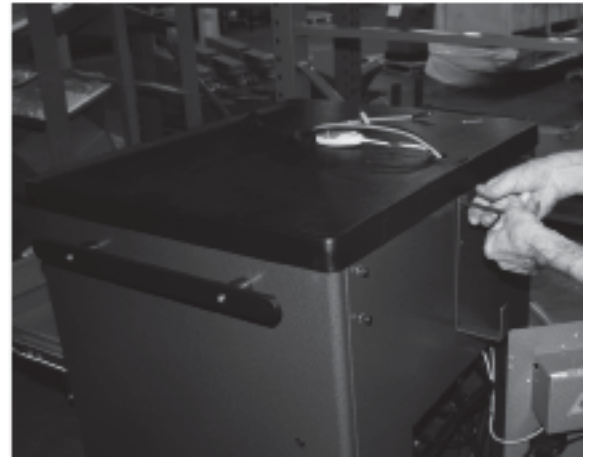

Figure 3



Figure 5



3. Locate rear shelf, monitor mounting bracket, and hardware, Figure 6.

4. Assemble the monitor mounting bracket to shelf as shown using provided hardware, Figure 7.

Figure 6

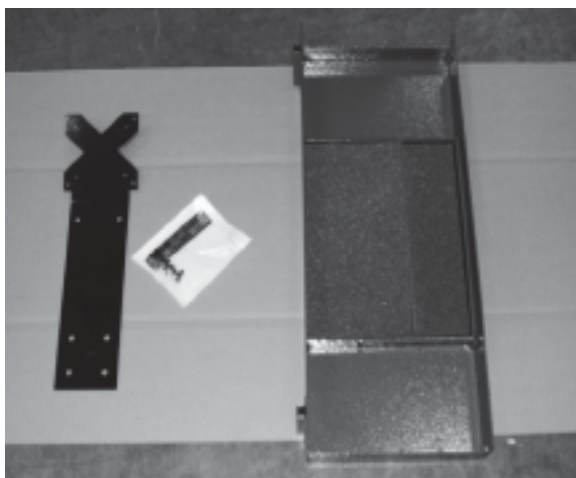

Figure 7



5. Hang shelf as shown, Figure 8, and tighten screws securely as shown, Figure 9.



6. Open monitor box and locate monitor, Figure 11, Assemble monitor to mounting bracket as shown, Figure 12.



Figure 11



Figure 12

7. Place keyboard, mouse, and mouse pad on cabinet top. Route all wires through shown hole, Figure 13.



Figure 13

8. Complete monitor, keyboard, and mouse wire connections, Figure 14-15.

Figure 14



Figure 15



9. If scanner is equipped with a battery, clip the wire tie holding the battery supply scanner cable, Figure 16a, and route scanner cable to scanner location, Figure 16b.

Figure 16a

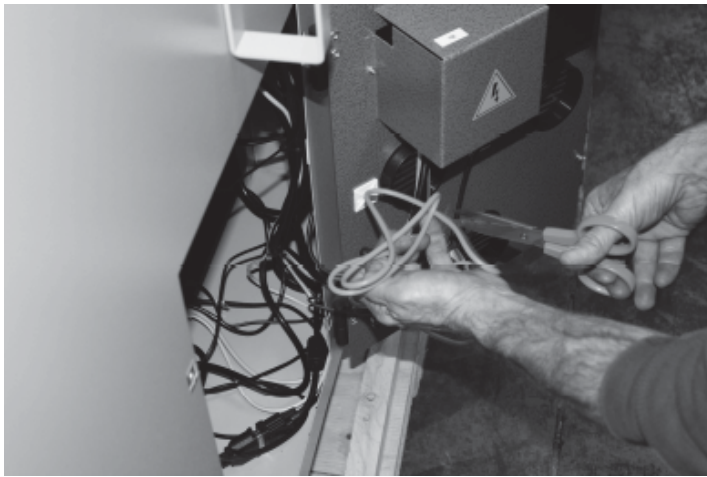

Figure 16b



Scanner Power:

Battery/Cable Power:

If the scanner is using battery power to operate, the on/off power light (Figure below) flashes. If the scanner is using cable power to operate, the on/off power light will remain on if the power switch.

Battery Charge: (If equipped with a battery)

The battery takes approximately 3 hours to fully charge.

There is a gauge on the front of the scanner that provides the level of battery charge still available on the scanner (See Figure Below). The number of lights that are on identify how much charge is left on the battery. A fully charged battery provides approximately 5 hours of operation. If there are 4 lights on, there is 87%-100% battery charge remaining (4-1/3 to 5 hours). 3 lights, there is 66% to 87% battery charge remaining (3-1/3 to 4-1/3 hours). 2 lights, there is 33% to 66% battery charge remaining (1-2/3 to 3-1/3 hours). 1 light, there is 10% to 33% battery charge remaining (1/2 to 1-2/3 hours). If the 1 light blinks on and off, then the battery is about to run out of charge.

ATTENTION After 8 hours the scanner will shut off automatically to reduce wear on the machine.

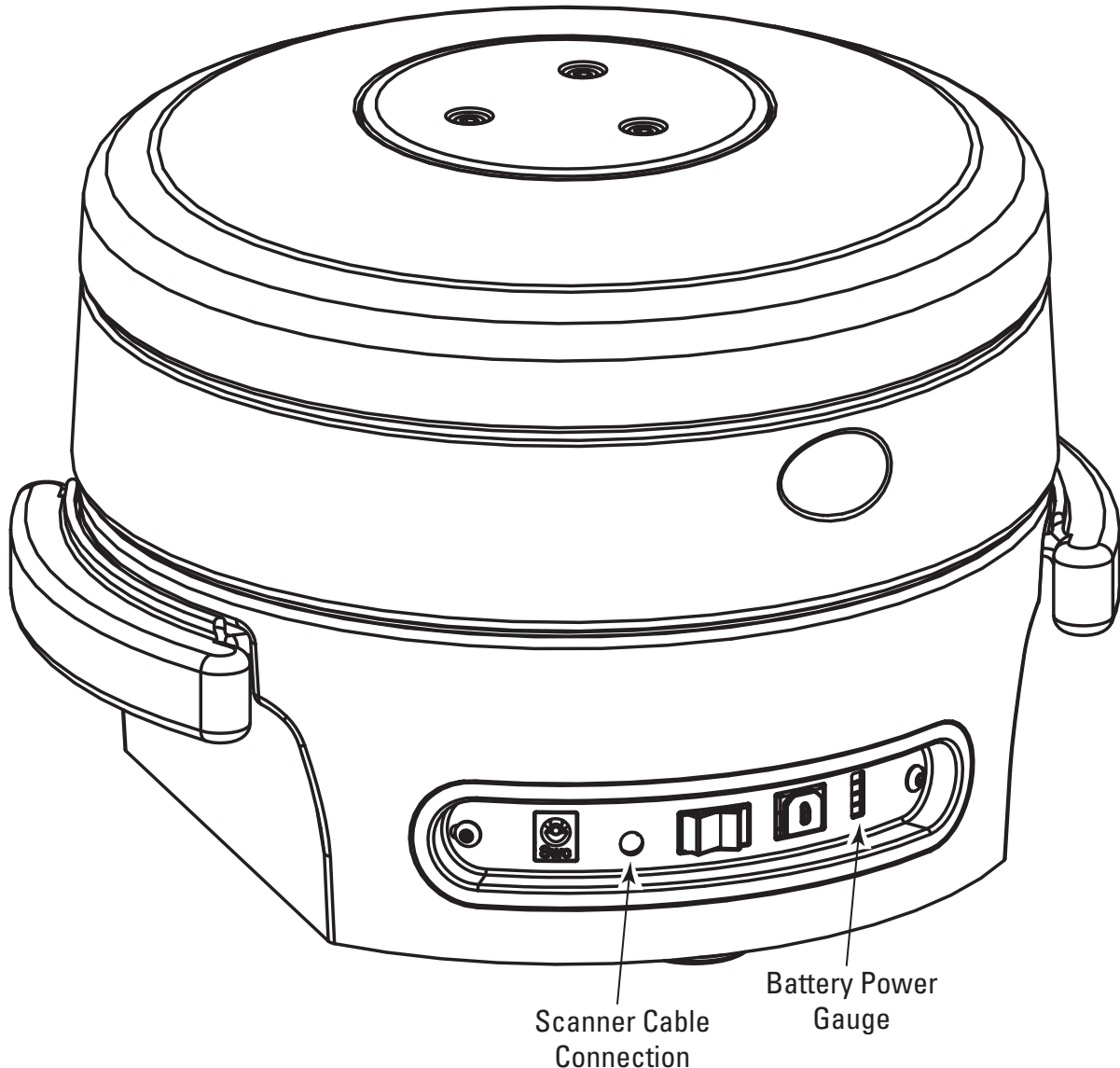

Position Workstation near work area and attach Power Supply Cable. Attach Scanner Power Cable end to Workstation. (See Figure 17.) Then attach Scanner Power Cable end to Scanner, Figure 18. Scanner 'on/off' switch is shown in Figure 19.

Computer and Body Scanner are precision electronic tools. Movement of components must be done with care. Do not move Workstation during a 'continuous' measurement or during program accessing. Please ensure cabinet is positioned so that full access to the disconnect switch is available at all times.

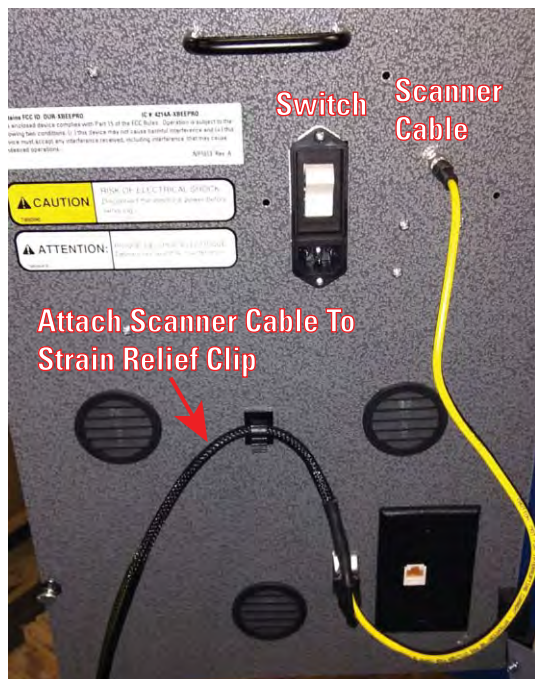

Figure 17

Scanner Cable



Power Supply Cable, 110V



Power Supply Cable, 220V



IMPORTANT Only use main power supply cords provided with the workstation. Replacement cords must be ordered from the factory. See parts breakdown for part numbers.

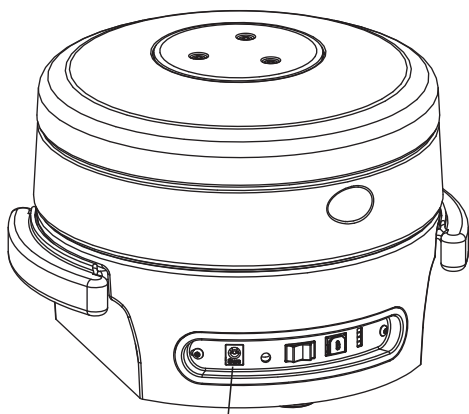

Scanner Cable Connection

Figure 18

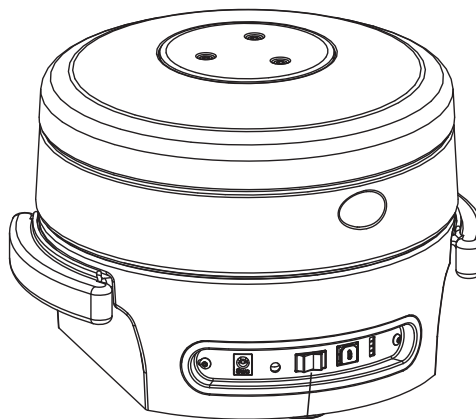

Scanner ON / OFF Switch

Figure 19

Body Scanner and Tray

The Truscan system measures on the principle of triangulation. The Body Scanner houses rotating Laser Lights that project toward light reflective Targets (each bearing a unique code) on vehicle's structure. Body Scanner also houses photo sensors that identify the angle of revolving laser reflections.

Targets 1 - 36 (and optional Targets 37-40) are interchangeable depending on length of pendant needed. Optional Targets 41 and 42 are used with a Target Base when measuring lower control arms. Optional Targets 43, 44, and 45 are used with the Optional Upper Body Bar when measuring strut tower and other upper body reference points.

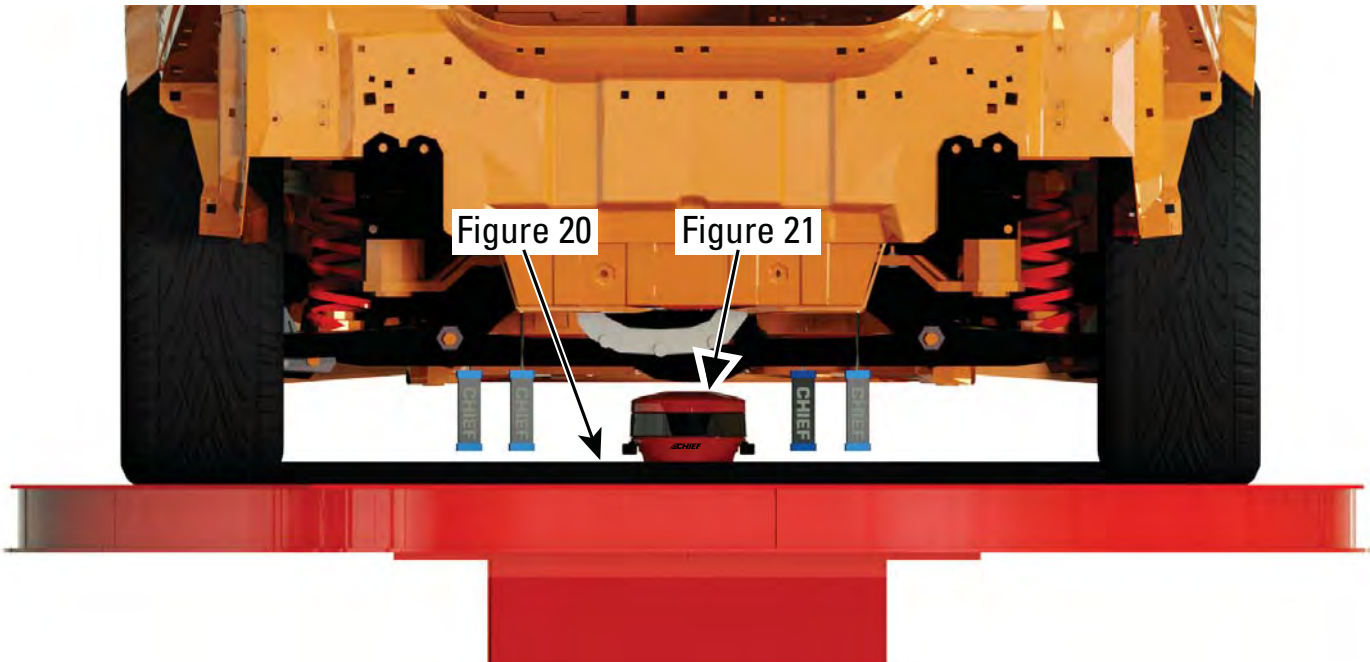

This information is transferred to computer which performs triangulation and Target identification functions. The Scanner's parabolic design filters out sunlight allowing for greater productivity.

Body Scanner Tray is the base upon which to position Body Scanner. Rubber strips on Tray's inside edges and insulating feet on bottom of Body Scanner help prevent metal-to-metal contact between Tray and Body Scanner.

Insert Body Scanner Tray below vehicle's center section (see Figure 20) and place Body Scanner on Tray (see Figure 21). Cable port must be under left side (driver's side) of vehicle. This positioning allows Body Scanner to be synchronized with computer program.

Body Scanner does not need to be square to vehicle or level. Make sure, however, it remains in Tray and Tray is stable. It is permissible to reposition Tray any time or shift Body Scanner in the Tray. Truscan re-calibrates any repositioning in its next measurement cycle.

Targets

All Targets are numbered and their reflective faces bear a unique code. (See Figure 22.) Most Targets are interchangeable, although some have specific uses. An assortment of clips, extensions and other attachment devices provide flexibility in Target placement. All specifications are provided from reference hole and bolt centers.

NOTE:

- 1) Although Targets numbered 1 - 36 (and optional Targets 37-40) are interchangeable, be consistent when placing them at reference points.
- 2) With the exception of optional Targets 41 -45, Targets can be used on either side of the vehicle. Optional Targets 41 and 42, which are primarily used to measure ball joint locations, must be used on the left and right side of the vehicle respectively. Optional Targets 43 and 44, which are used to measure strut tower locations, must be installed on the Lower Bar of the Upper Body Bar Assembly directly below their respective Pointers. Optional Target 45 must be in the center of the Lower Bar.

Target Base

Any Target except optional Targets 43, 44 and 45 can be used with the Target Base. (See Figure 23.) Target Base sits on platform and Target is projected upward from it to a reference point. When using Target Base to project a Target to a specific reference point, the Target Pendant requires the addition of a Cone Attachment (see Figure 23) to compensate for absence of an attachment or clip. Optional Targets 41 and 42 are used with the Target Base to make comparison measurements of ball joint locations.

Attachments / Clips

A variety of Attachments, Clips and Extensions allow Targets to be mounted to practically any reference hole or bolt. These include Bolt Attachments, and Hole Attachments.

IMPORTANT: When using different attachments than what is suggested in the Point Information Dialog Box, input the correct information in the Change Attachment Dialog Box.

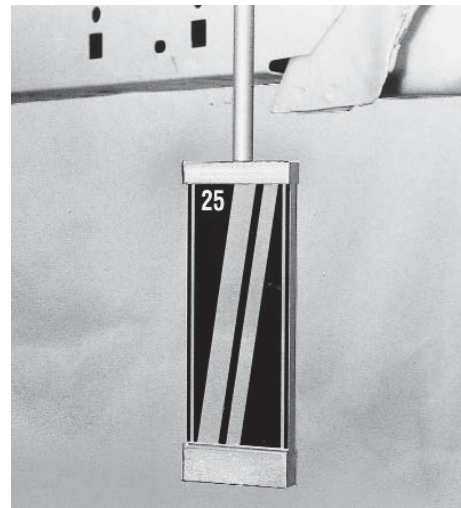
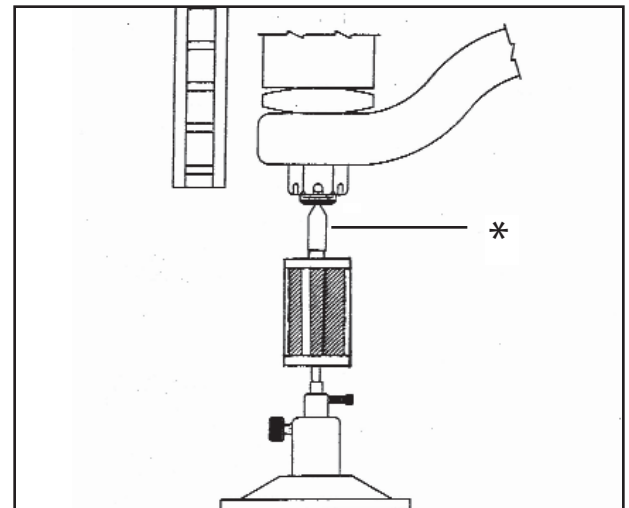

Figure 22



* Cone Attachment

Figure 23

Bolt Attachments

Bolt attachments work equally well on the bottom of a structural component or on the side of a structural component. The nylon base of each attachment swivels to allow for easy Target adjustments.

Metal Clip Style 'Bolt Attachments' have a strong gripping capability and are designed to fit a wide range of bolts (and nuts) used on a vehicle's structure. The small size grasps bolts/nuts with a 10 to 20mm diameter. The medium size grasps bolts/nuts with a 15 to 25mm diameter, and the large size grasps bolts/nuts with a 25 to 35mm diameter. (Figure 24 and its inset show an example of a nylon base bolt attachment.)

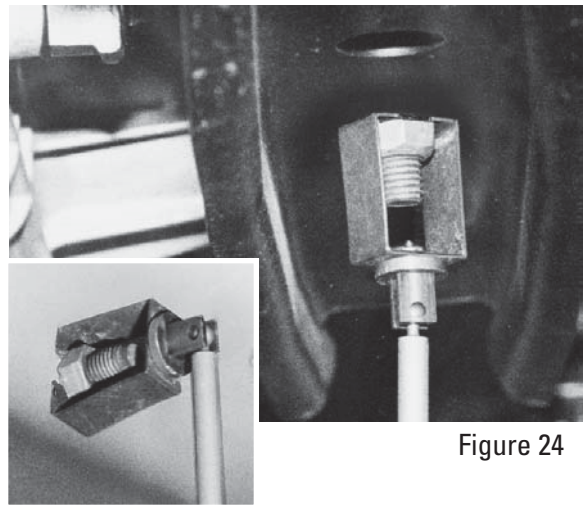

Figure 24

Hole Attachments

Hole Attachments snap into all types of reference holes. Most work equally well on the bottom or side of structural components. The attachments feature a nylon base or a mounting clip that allows for easy Target adjustments.

IMPORTANT: When using Hole Attachments in elongated (oval) reference holes, refer to Point Information Dialog Box for correct positioning.

Aluminum Snap In Attachments - snap into all types of reference holes. They are made of aluminum and are provided in varying sizes ranging from 10 to 32mm in diameter. (Figure 25 and its insets show an example of an aluminum snap-in attachment.)

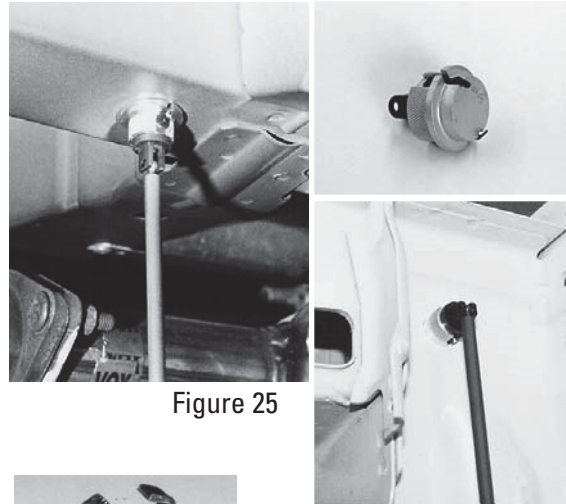

Figure 25

Bottom Hole Clips - are small metal clips that allow Targets to be mounted to horizontal reference holes measuring 5 to 10mm in diameter. (See Figure 26.)



Figure 26

Collet Kit (optional). (See Figure 27.)

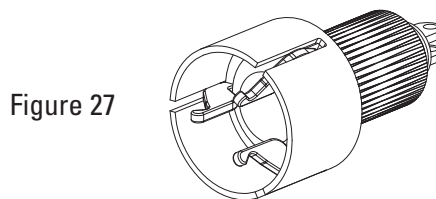

Figure 27

Threaded Attachments (optional). (See Figure 28.)

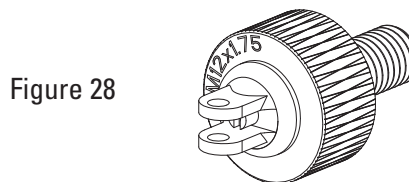

Figure 28

Extruded Hole Attachments - mate with both horizontal and vertical reference holes. Spring tension holds the attachment within the hole so that Targets can be mounted as shown in Figure 29 and its inset.

Side Hole And Extended Side Hole Clips - are used to mount Targets to vertical reference holes. The looped portion of the attachment hooks inside the reference hole providing the support needed for mounting Targets. (See Figure 30 and its inset.) Extended length side hole clips are provided to help technicians work around obstructions.

Optional Attachments

IMPORTANT: When using different attachments than what is suggested in the Point Information Dialog Box, input the correct information in the Change Attachment Dialog Box.

Optional Magnetic Attachments

Magnetic Attachments (optional) (see Figures 31 and 32) are used on bottom of structural members when reference holes or other mounting locations are not accessible. This attachment, used primarily for comparative measurements, should be positioned so that its vertical surface is flush with vertical surface of structural member it mounts to. The Target can then be mounted in attachment's clip.

The magnet on the attachment is strong and will maintain its holding power if cared for properly. A Magnet Keeper (see Figure 18 inset) should be positioned on magnet when the attachment is not in use.

IMPORTANT: Never use arc welder or heat near Magnetic Attachment as this tends to reduce its holding power.

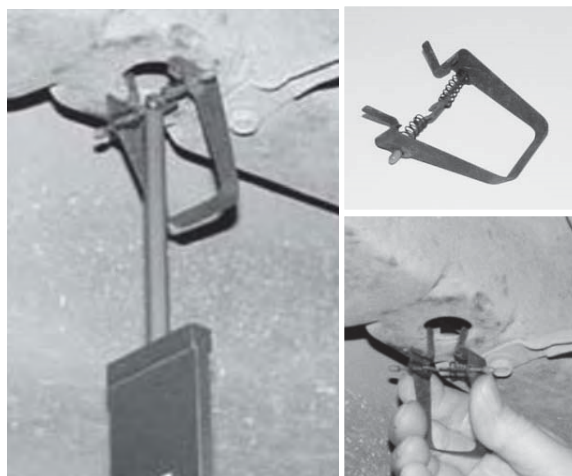

Figure 29

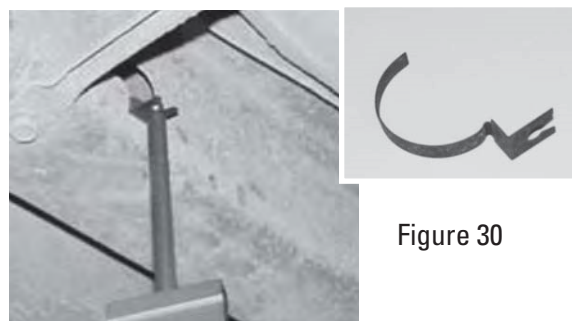

Figure 30

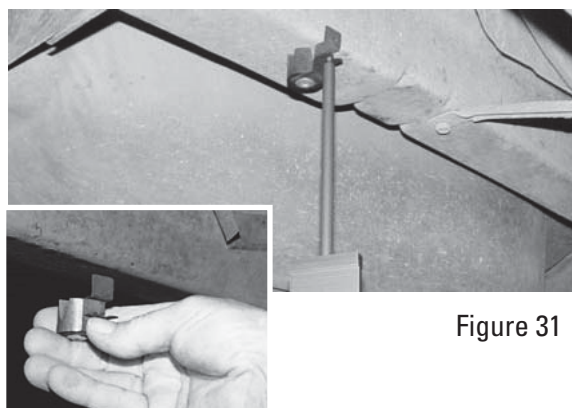

Figure 31

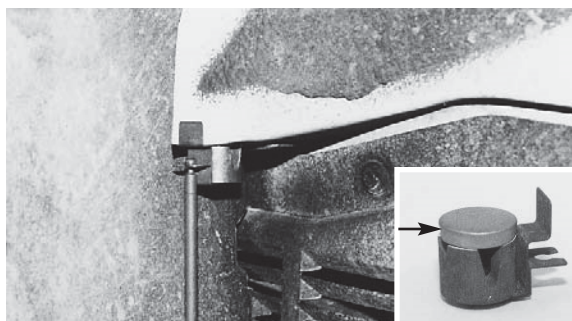

Figure 32

Optional Target Extension Rods

Target Extensions (optional) - are available in lengths of 156mm and 256mm. (See Figure 33.) A third extension is C-shaped for reaching around obstructions. The Extensions allow greater flexibility when extra length is needed and when mounting Targets in locations where obstructions prevent normal installation. (See Figures 34 and 35 and Figure 34 inset.)

Truck Attachment Package

The Truck Attachment Package (optional) is occasionally referred to as "Drawer 4". It consists of Magnetic Bolt Head Attachments, Threaded Attachments and extra long Targets. The components of the package allow the operator to measure the end sections of high ground clearance vehicles.

Magnetic Bolt Head Attachments (optional) - have a strong gripping capability and are designed to fit a wide range of bolt heads. (Figure 36 and its inset show an example of a magnetic bolt head attachment.)

Threaded Attachments (optional) - allow operator to thread the attachment onto extruding bolt threads. (Figure 37 and its inset show an example of a threaded attachment.)

Long Targets (optional) - allow operator to mount Targets in the end sections of high ground clearance vehicles. (See Figure 38.) Targets 37, 38, 39 and 40 feature longer stems that position the Target's reflective face on same plane as the body scanner lasers.

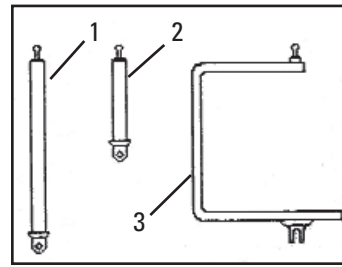

- 1 - 256mm (red)
- 2 - 156mm (blue)
- 3 - C-Shaped Extension

Figure 33

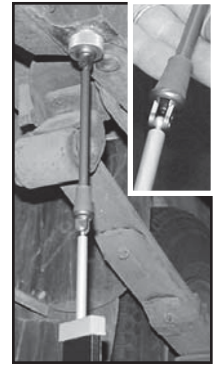

Figure 34

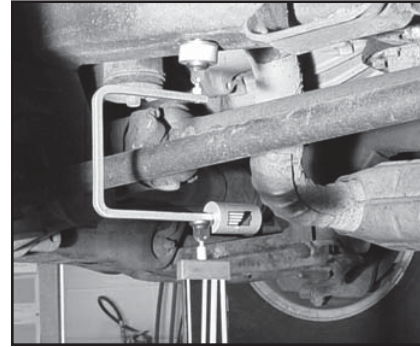

Figure 35

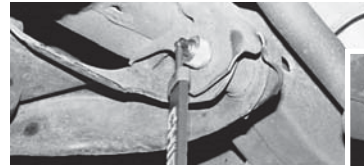

Figure 36



Figure 37

Figure 38



Optional Upper Body Bar Assembly

The Upper Body Bar Assembly (optional) consists of two horizontal bars joined by a pair of Vertical Scales. (See Figure 39.)

Pointers project from Pointer Housings on Upper Bar to strut tower or other upper body reference points. Pointers are provided in 'cone-shaped' configurations in lengths of 102mm and 178mm.

Three Targets (Nos. 43, 44, 45) mounted to Lower Bar measure height, width (centerline), and length of strut tower or other upper body reference points.

In addition to components listed, Bolt Hole Caps and Stud Hole Caps (ranging from 5 to 17mm in diameter) allow the assembly to be mounted to open bolt holes or studs. (See Figures 40 and 41.) The configuration of the cap positions the pointer at center of hole or stud.

Figure 39



Figure 40

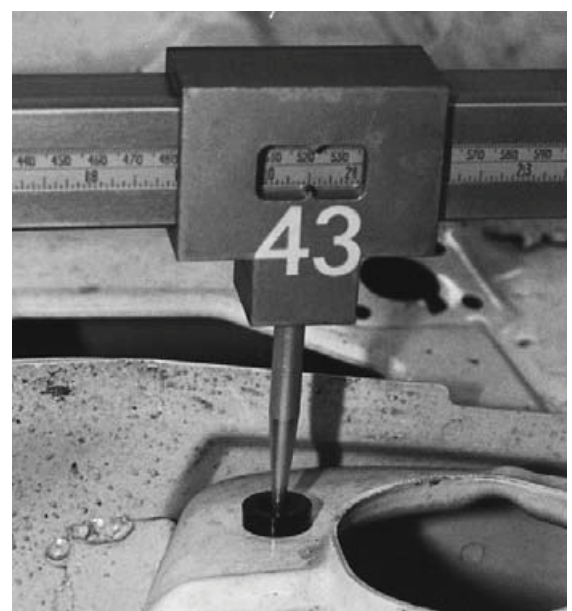
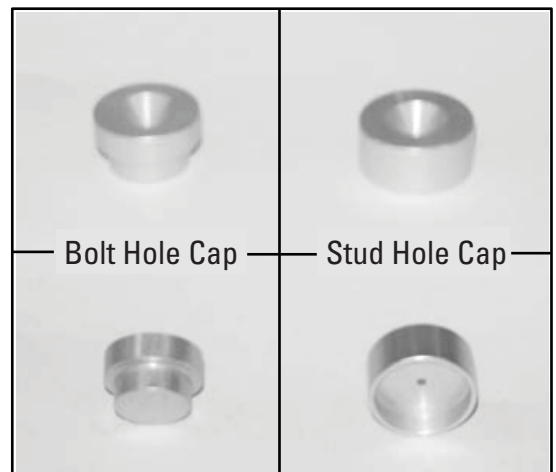

Figure 41

Optional Upper Body Bar (continued).....

To install the Upper Body Bar, attach one of the Vertical Scales to Upper Bar and place assembly's pointers on reference points. (See Figure 42.) Then tighten Pointer Housings (see Figure 43); however, if a reference point appears to be misaligned, do not tighten its Pointer Housing. Next, install Lower Bar (with three Targets installed) and remaining Vertical Scale. If needed, adjust height of Lower Bar to enable Body Scanner to view all three Targets.

IMPORTANT:

- 1) Target Number 45 must be in center of Lower Bar and Target Numbers 43 and 44 must be under their respective Pointers. (See Figure 44.)
- 2) Body Scanner's Lasers should strike near center of Target faces.
- 3) Length of Vertical Scales must be equal, one side of vehicle to the other.

Figure 42



Figure 43



Figure 44



Spacers and 3 Inch Bolts

The Truscan Measuring System works well with all of Chief's anchoring systems; however, a slight modification may be required if using Chief's original Universal Anchoring System. Whenever the anchoring tubes of this system prevent the mounting of Targets in the rear corners of the vehicle's center section, operators should offset the clamp bars using the spacers and 3 inch bolts provided. The spacers and bolts position the rear anchoring stands wider than normal allowing Targets to hang vertically.

Chief Specifications Data

Specifications of domestic and foreign vehicles are stored in the Truscan Computer along with provisions for periodic updates.

Literature

Literature provided with Truscan system includes Truscan Users Manual and Truscan Parts Manual.

In addition to this printed literature, the Truscan system features an On-Line Help Text and a Tutorial (requires optional speakers to listen) that is readily accessible whenever using the program. In addition, there is also an On-Line How To Use Help System. (These Help features are addressed in greater detail later in this manual.)

DVDs

When using DVDs, handle them correctly. To insert, slide it carefully into Computer drive (see Figure 45) until it seats in the drive. To remove, select Eject (from menu options on screen). Grasp DVD at label and slide it from drive slot.



Figure 45

Update DVDs

The Computer provided with the Truscan system comes fully loaded with operational software, Vehicle Graphics and vehicle specifications. Periodic updates to these are made available as needed. Updates are sent in DVD format. To make updates, refer to procedures identified in Help Text and any special instructions mailed with the update DVD.

COMPONENT MAINTENANCE

(See also Users Manuals For Computer And Printer)

Other than cleaning, factory maintenance by qualified technicians is required for all components. Be sure system's power is 'off' while cleaning is performed. In dusty or dirty environments, periodic cleaning is necessary. Specific instructions for cleaning critical components are described below.

Wipe all parts clean using a lint-free, low-abrasion cloth using only an ammonia-based glass cleaner. Never use solvents or alcohol-based cleaners of any kind on any part of the Truscan System.

Body Scanner Care

Do not plug or unplug cable from Body Scanner unless it is turned off.

Keep Body Scanner away from areas being undercoated, primed or painted. Keep heat away from Body Scanner when using a torch for thermal stress relieving of structural components.

Clean all Body Scanner parts with a lint-free, low-abrasion cloth and a good quality glass or ammonia cleaner. Never use solvents or alcohol-based cleaners on Body Scanner glass.

Care of Targets

Keep Targets away from areas being undercoated, primed or painted, and away from heat when using a torch for thermal stress relieving of structural components.

Use a lint-free, low-abrasion cloth and a good quality glass or ammonia cleaner to clean Targets. Do not use solvents.

Avoid scratching or gouging the Target's reflective surface.

Workstation (Keyboard, Monitor, Computer)

Clean monitor screen and other external parts (keyboard, computer, etc.) with a lint-free, low-abrasion cloth, and a good quality glass or ammonia cleaner. Do not use solvents or alcohol-based cleaners on Monitor screen or other computer parts. Be sure system's power is 'off' while cleaning is performed.

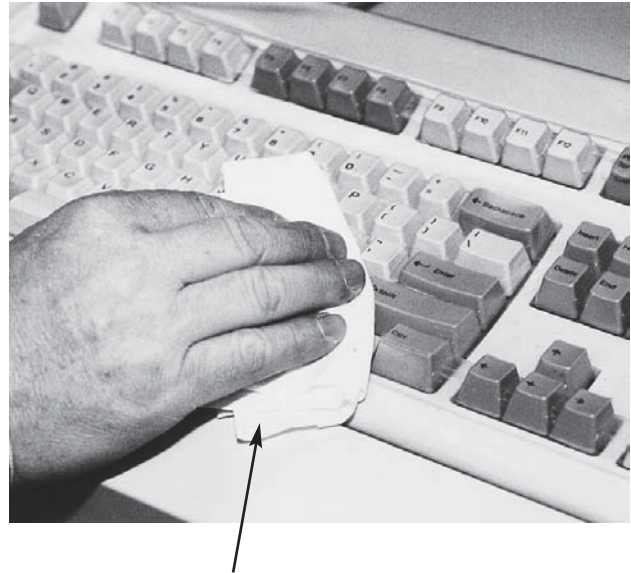

Lint-free, low abrasion cloth.

Figure 46

Truscan Galileo Plate Retrofit Kit (CK140036) Installation Instructions

1. If there is an internet cable connection from the shop, disconnect it from the Network Jack Assembly – RJ45 (788067) that is located on the Phone Jack Cover (788042) on the Cabinet Back Panel as shown in figure 47.
2. Remove the Network Jack Assembly – RJ45 (788067) and the RJ11 & RJ45 Jack Plug (788089) from the Phone Jack Cover (788042) as shown in figure 48. If there is not a network jack assembly (or other configuration), just remove the items to ensure there are through holes at each of these locations.
3. Remove the nuts holding Phone Jack Cover (788067) to the Cabinet Back Panel and attach the Wall Plate with Bristles (CK130081) provided as shown in figure 48.
4. Install Power Supply Assembly, Velcro Only (CK110140). Do this by removing the two protective plastic strips from bottom of Velcro and adhere to inside of back panel or inside of cabinet itself. Make sure that the AC cord going to the Power Supply is plugged into an outlet within the cabinet.
5. Attach the USB 10M Cable (CK130082) into the computer and thru the Wire Bristle Wall Plate installed in Step 3 above.
6. Attach the Scanner Extension Power Cord (CK130083) to the barrel end of the Power Supply Assembly (CK110140) and thru the wire Bristle Wall Plate installed in Step 3 above.

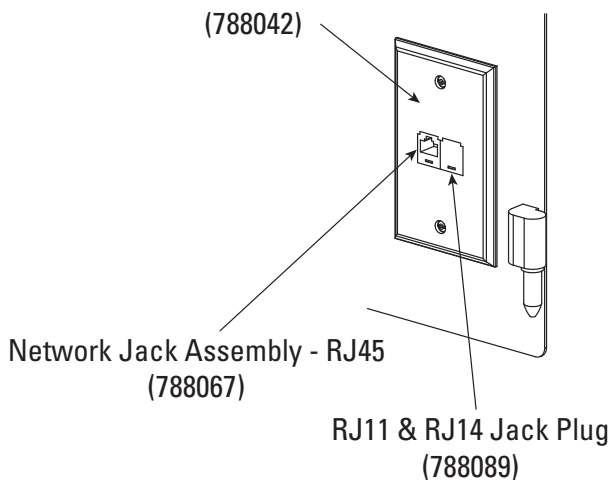

7. Replace current Scanner Tray on back of Cabinet with new Scanner Tray (CK130029), figure 50.
8. Place Scanner Cover (CK130054) provided onto Scanner to protect scanner from debris when not in use.
9. Add adhesive wire tie mounting square to back panel, figure 47, to provide strain relief for both USB and Scanner power cord.

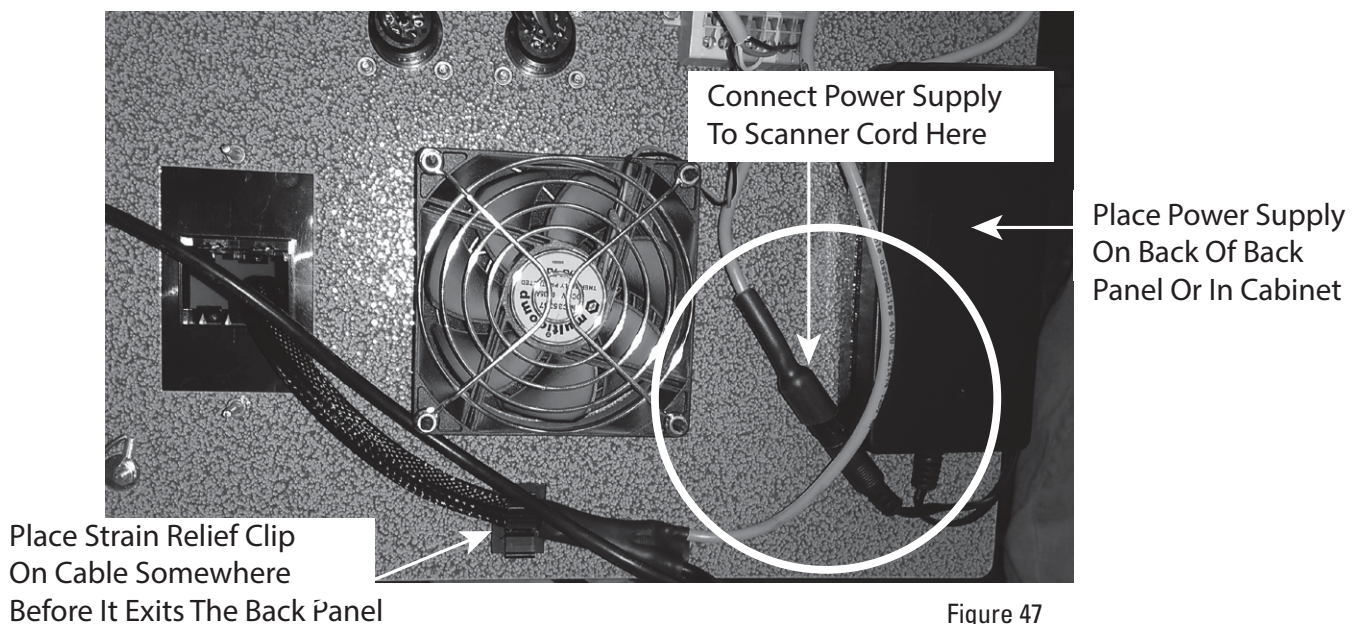
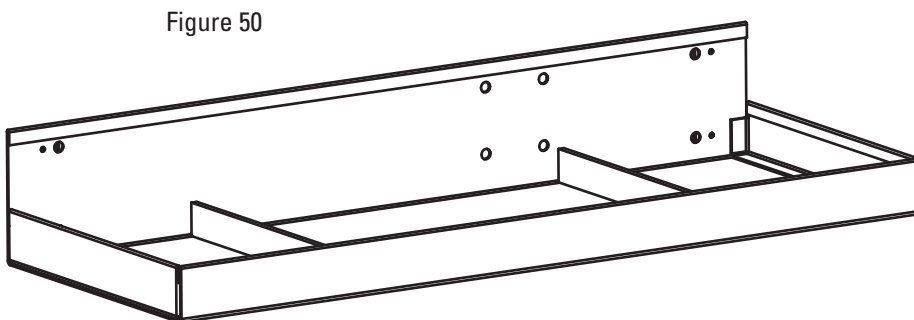
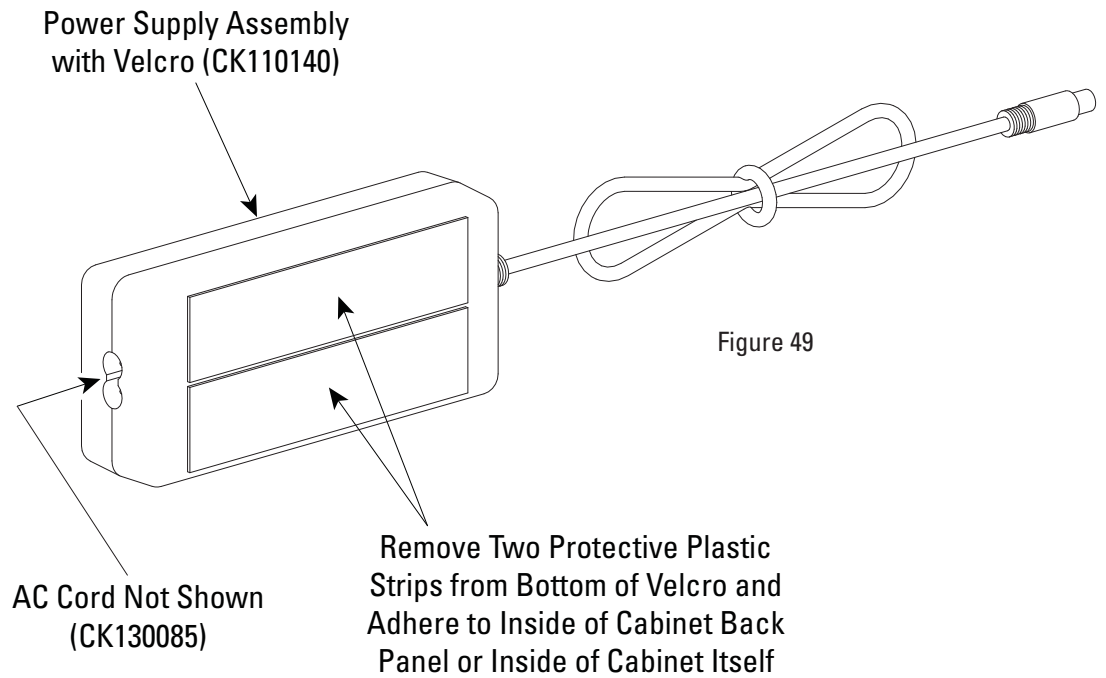
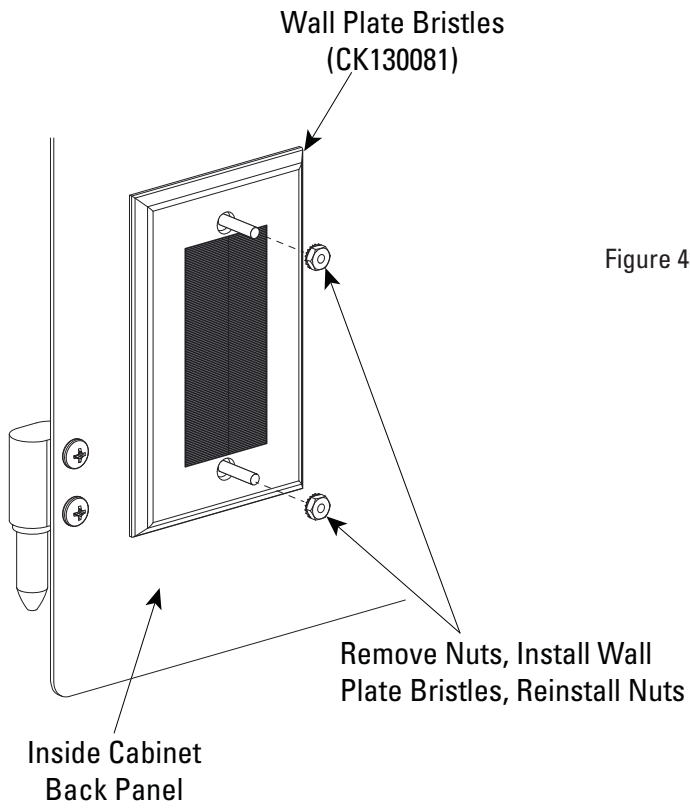

Figure 47



Vector Galileo Back Panel Retrofit Kit (CK140020) Installation Instructions

1. Remove Back Panel on back of existing cabinet including all wires connecting Back Panel to Cabinet. The back panel will be discarded so all wires can be cut from back panel.
2. Remove all existing Power Cords that go from monitors, printer, and computer.
3. Attach Powerstrip Bracket Assembly (CK110040) to Cabinet using two #12x1/2 Self Tapping Screws (796556) in accordance with Figure 50a. Make sure the Cabinet Door can close after installation.
4. Connect two (CK720331) Power Cord from both monitors to powerstrip. Wiring schematic shows this configuration.
5. Connect (CK130044) Power Cord from printer to powerstrip. Wiring schematic shows this configuration.
6. Connect (CK720331) Power Cord from computer to power strip. Wiring schematic shows this configuration.
7. Attach Back Panel Assembly, CSHS (CK110039) to cabinet.
8. Attach USB Cable from Back Panel Assembly (CK110039) to computer.
9. Attach AC Power Cord from Back Panel Assembly (CK110039) to powerstrip.
10. Attach Network Jack Assembly – RJ45 (788067) from Back Panel Assembly (CK110039) to computer.
11. Attach Grounding Wire from Back Panel (CK110039) to cabinet for ground.
12. Connect USB 10M Cable (CK130082) to back of Cabinet and wrap on existing cable hanger.
13. Connect Scanner Power Cord (CK110047) to back of Cabinet and wrap on existing cable hanger.
14. Reconnect shop Internet Cable to Network Jack Assembly - RJ45 (788067) on Back Panel (CK110039) if required.
15. Finally, Connect either 110V Power Cord (CK110048) or 220V Power Cord (CK110049) to Back Panel Assembly (CK110039).
16. Replace current Scanner Tray on back of Cabinet with new Scanner Tray (CK130029), figure 50b.
17. Place provided Scanner Cover (CK130054) onto Scanner to protect from debris when not in use.
18. If scanner is equipped with a Battery, clip the wire tie holding the Battery supply Scanner Cable, figure 50c, and route Scanner Cable to Scanner location, figure 50d.

Figure 50a

5/8" From Front of Cabinet (Not Including Doors)

12 5/8"

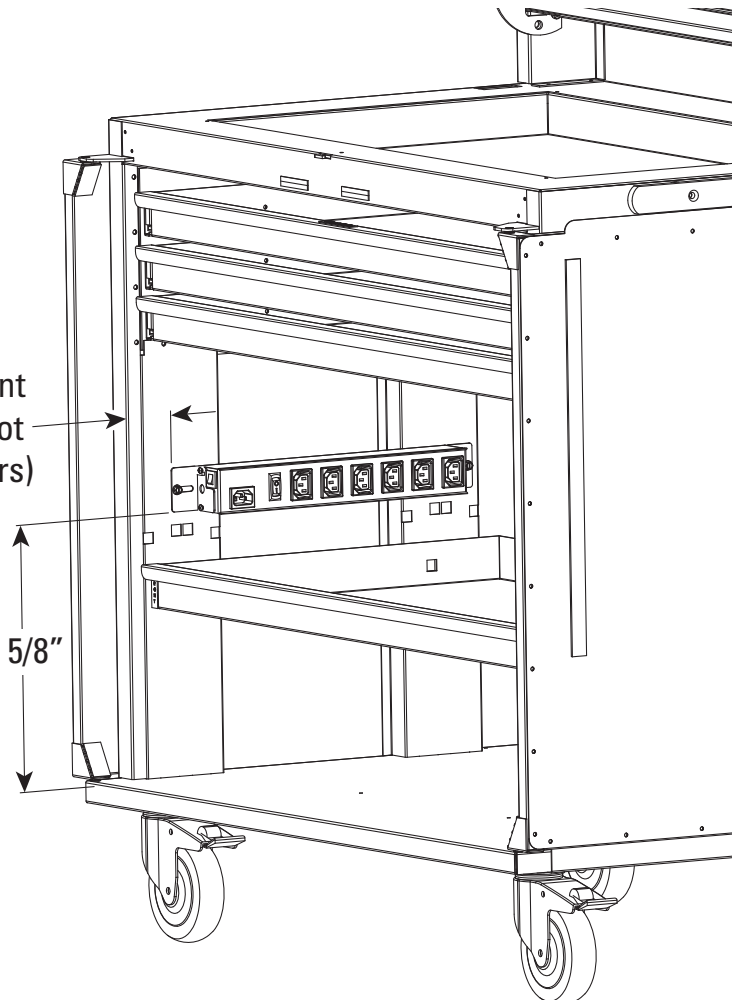

Figure 50b

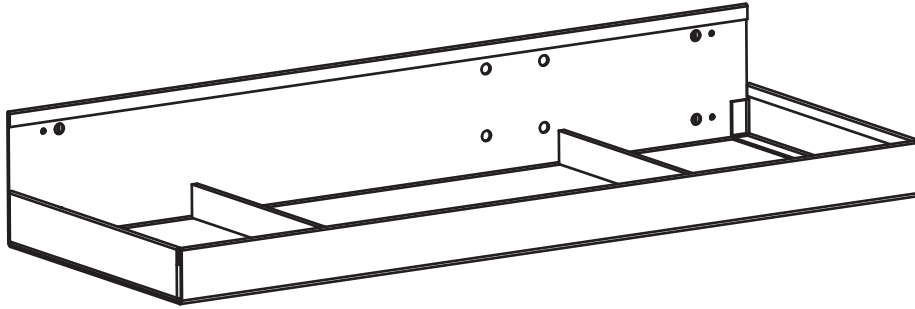

Figure 50c

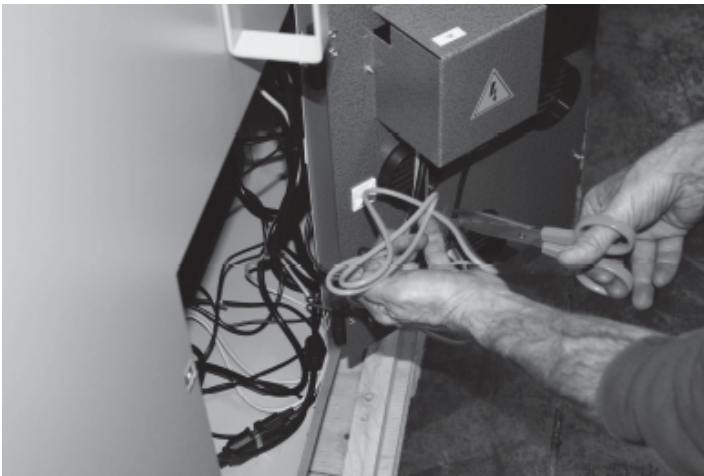
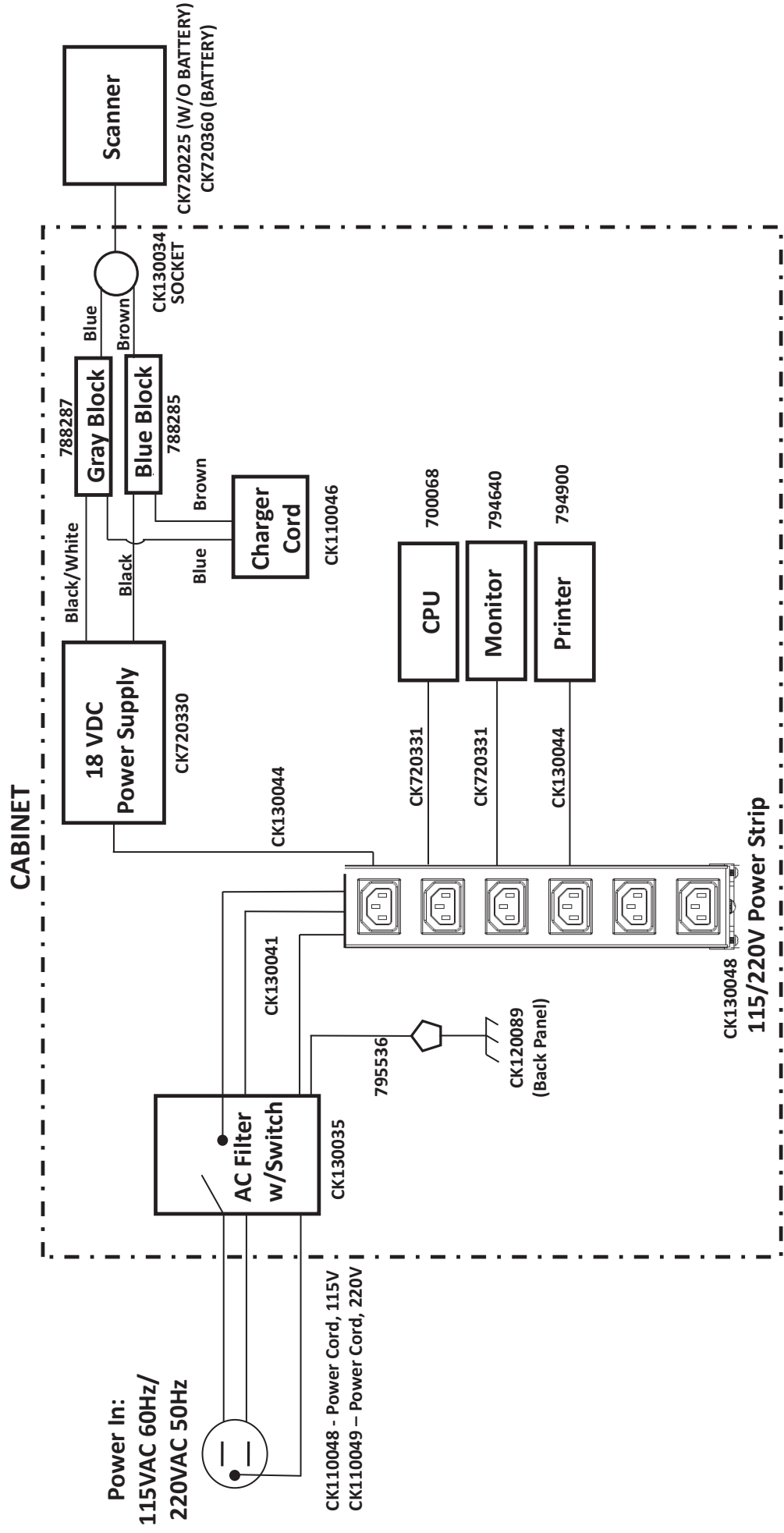

Figure 50d



TRUSCAN SCANNER MAPPING SYSTEM BLOCK DIAGRAM/SCHEMATIC



CABINET

Power In:
115VAC 60Hz/
220VAC 50Hz

CK110048 - Power Cord, 115V
CK110049 - Power Cord, 220V

CK130048
115/220V Power Strip

Scanner

CK720225 (W/O BATTERY)
CK720360 (BATTERY)

788287
Gray Block

788285
Blue Block

CK130034
SOCKET

Black/White

18 VDC
Power Supply

Charger
Cord

CK110046

CPU
700068

Monitor
794640

Printer
794900

CK130044

CK720331

CK720331

CK130044

CK130041

CK130035

795536

CK120089
(Back Panel)

Power Strip Connections

POWER
INPUT

PC

SCANNER

PRINTER

MONITOR

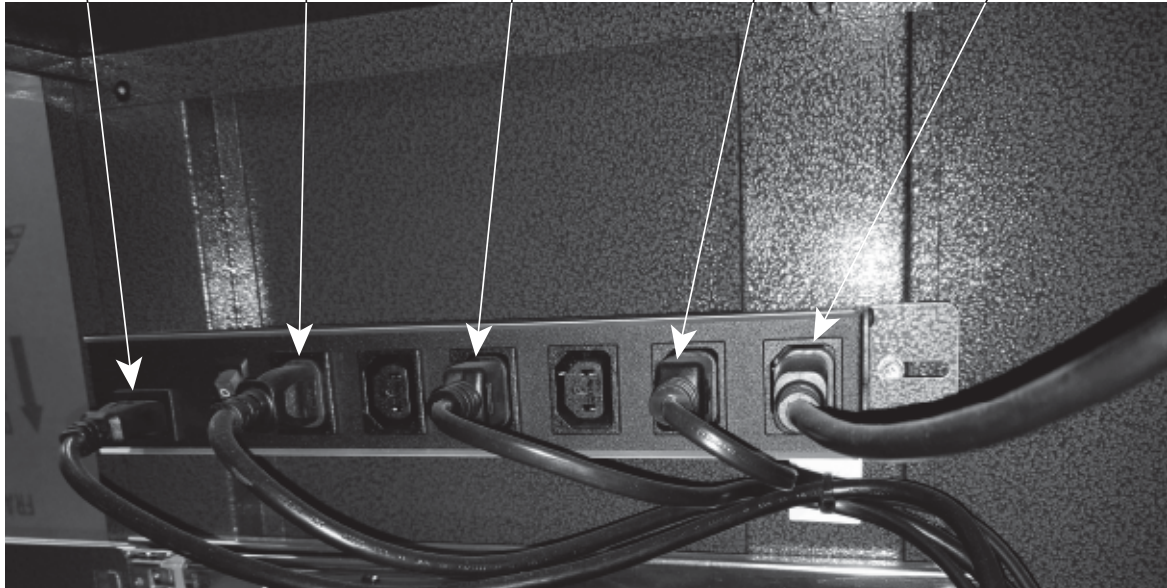

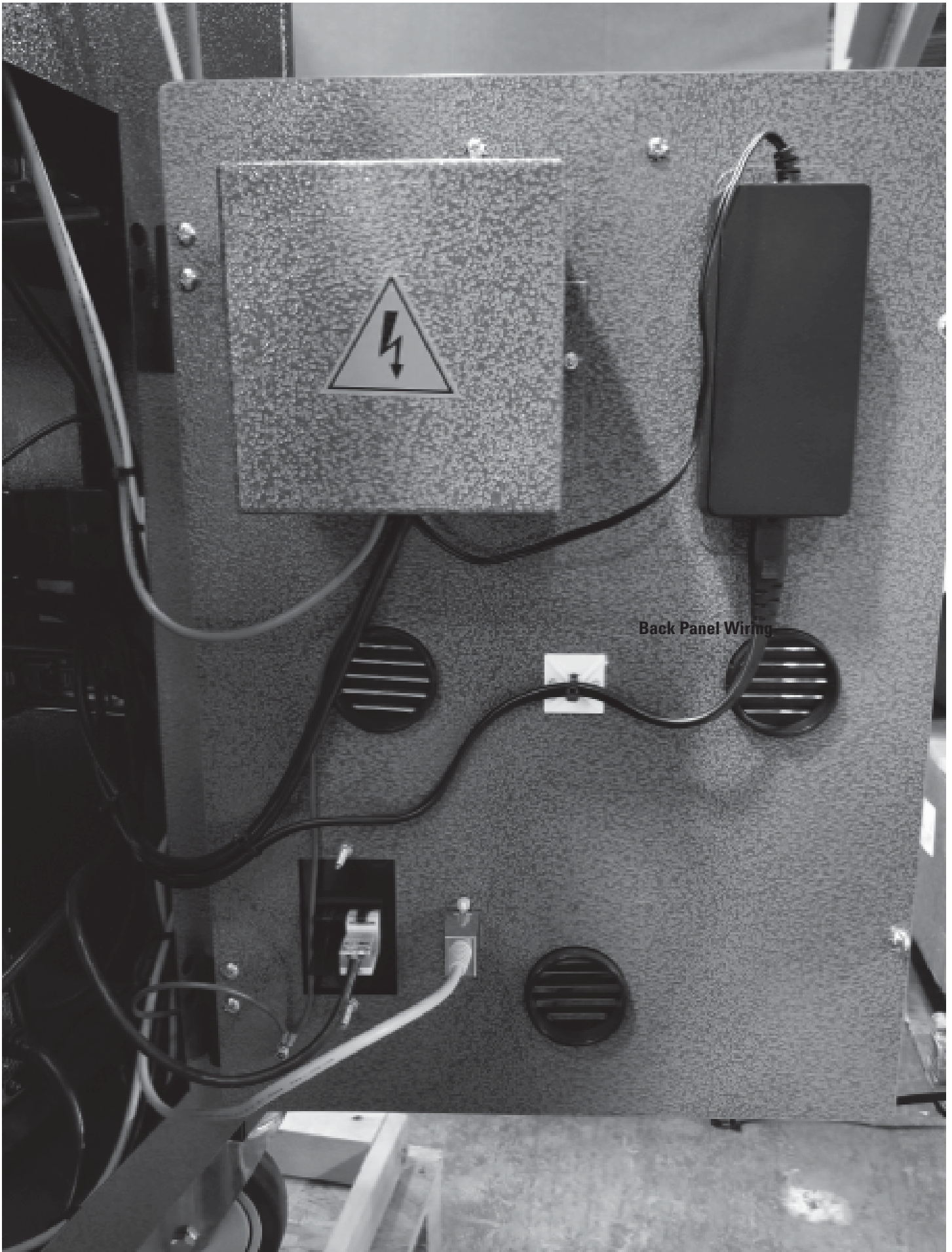

Back Panel Wiring

Front View
Back Panel Assembly, CSHS
(CK110039)

Back View

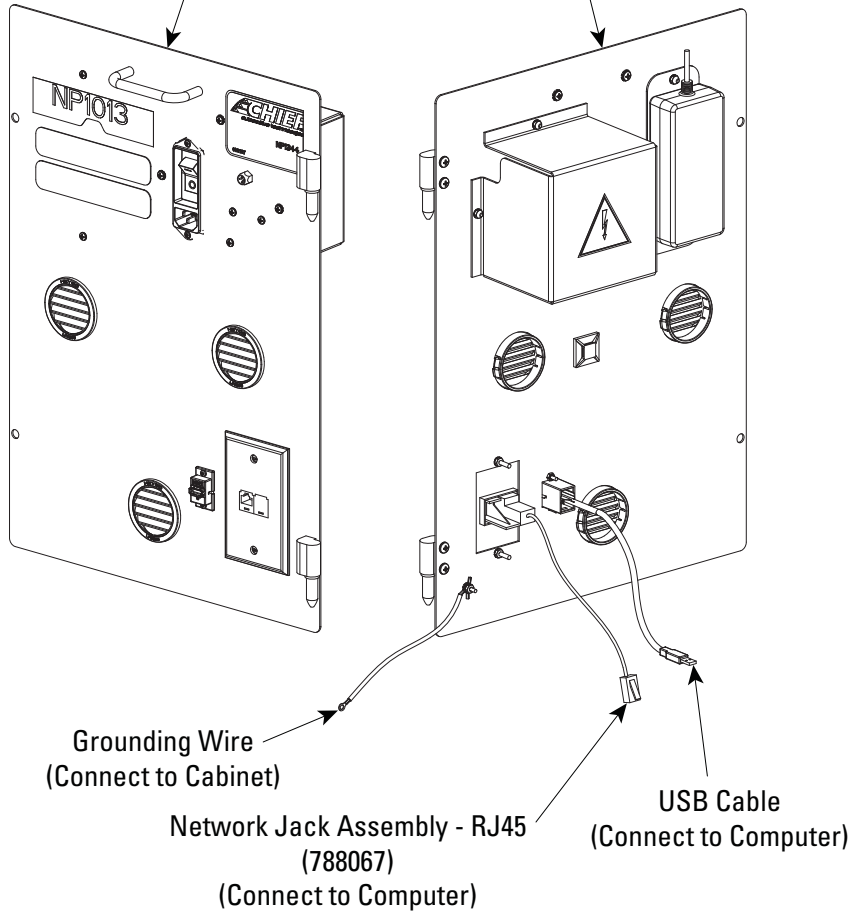

Figure 51

Front View

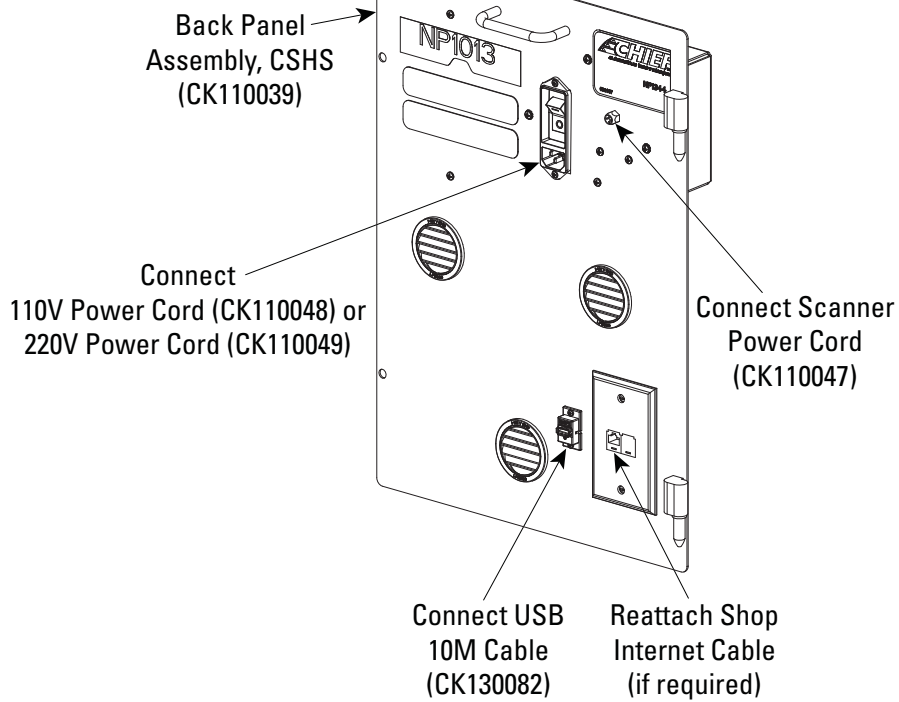
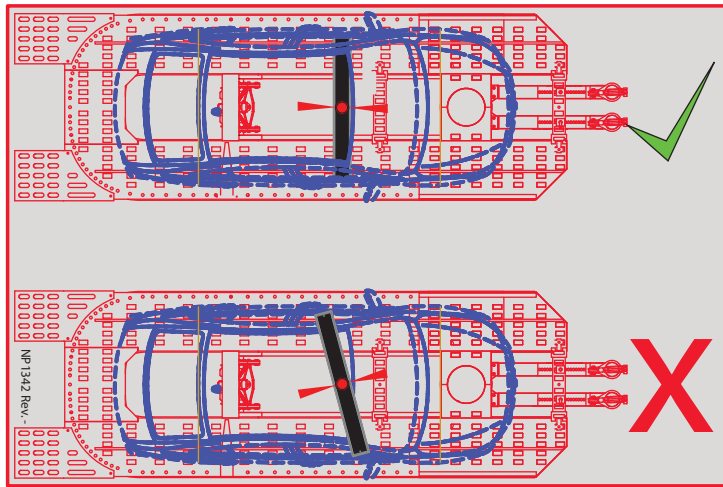
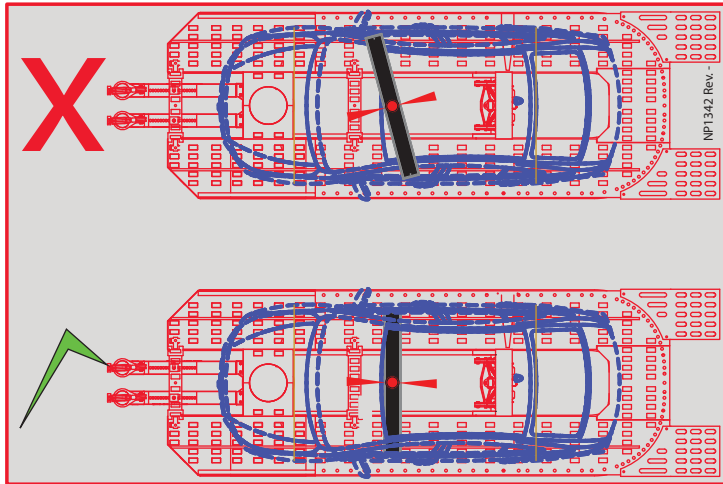

Figure 52



Please Decals onto ends of scanner tray

Galileo Verification Instructions

Galileo Verification Instructions

1. Attach a Set Screw, 8-32NC x .75 Long (796221), to Targets #7 and #8, see figure 53.
2. Attach Target Stems (CK130088) to Targets #7 and #8, see figure 54.
3. Remove both Uni-Strut 4" Pointers (620947) or whatever items are attached to the Upper Bar Assembly Upper Body Bar (799014) as shown in figure below, see figure 55.
4. Place Targets #7 and #8 onto Upper Bar Assembly Upper Body Bar (799014) as shown in figure below, see figure 56.
5. Tighten Set Screws that hold Targets #7 and #8 in place.
6. Slide both Targets #7 and #8 out from center to EXACTLY 1m. THIS NEEDS TO BE AS ACCURATE AS POSSIBLE, see figure 57.
7. Place the Upper Bar Assembly Upper Body Bar (799014) on a flat surface. Place the Scanner 6 feet +/- 3 inches from Bar and centered as shown in Figures below. Angle Target Faces toward scanner. See Figures 58 and 59.

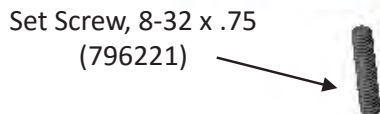
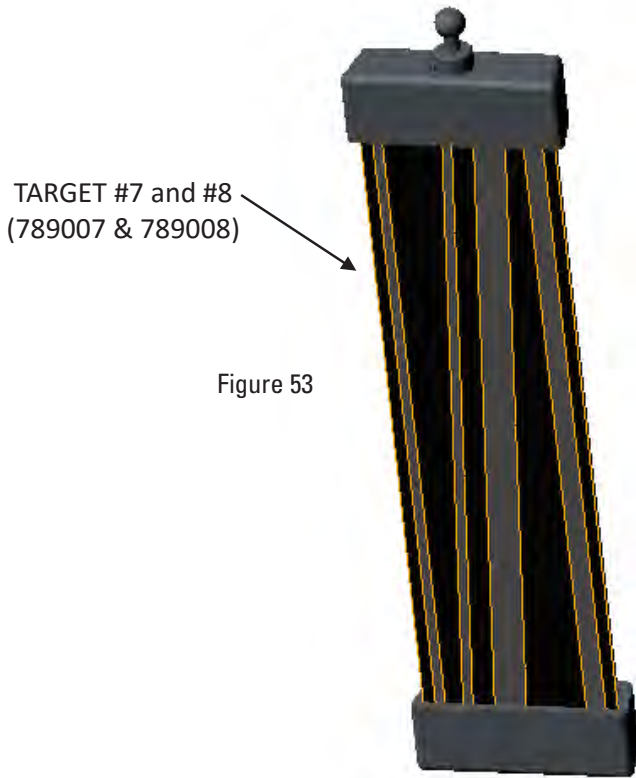

TARGET #7 and #8
(789007 & 789008)

Figure 54

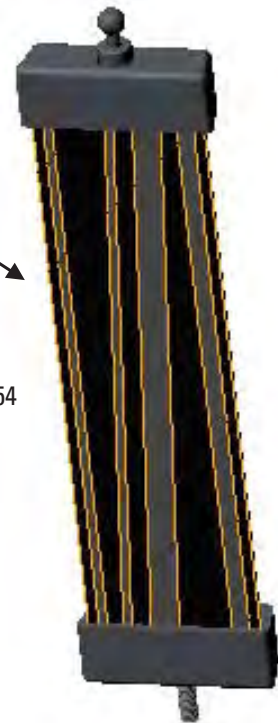

Target Stem
(CK130088)

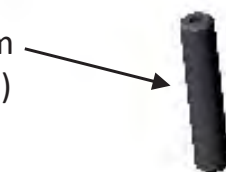

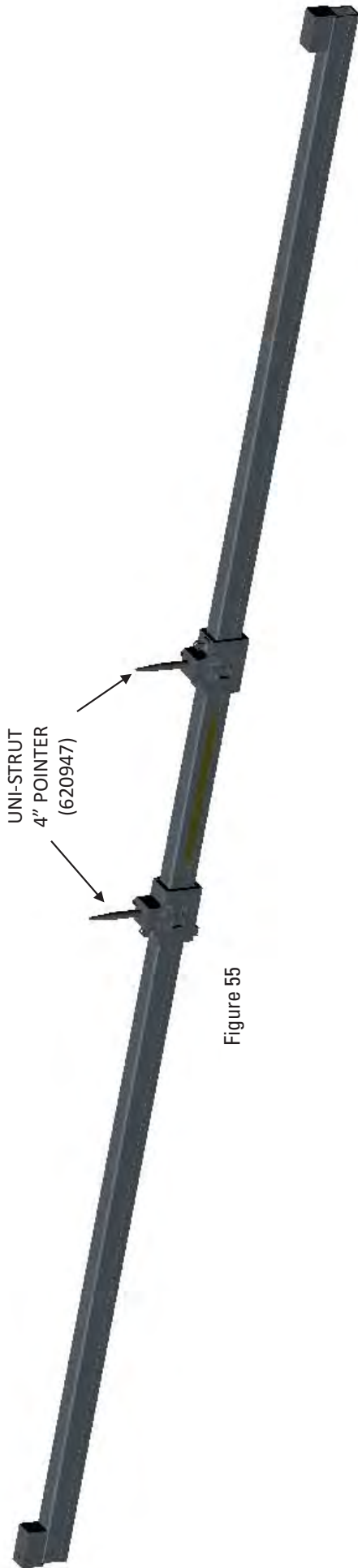

Figure 55

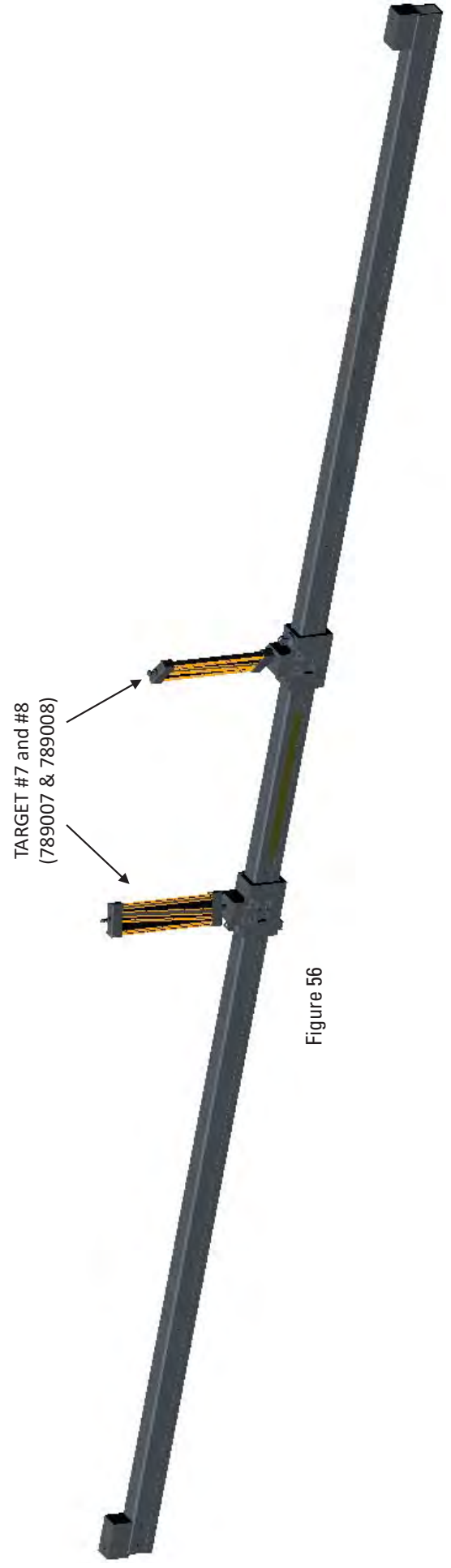

Figure 56

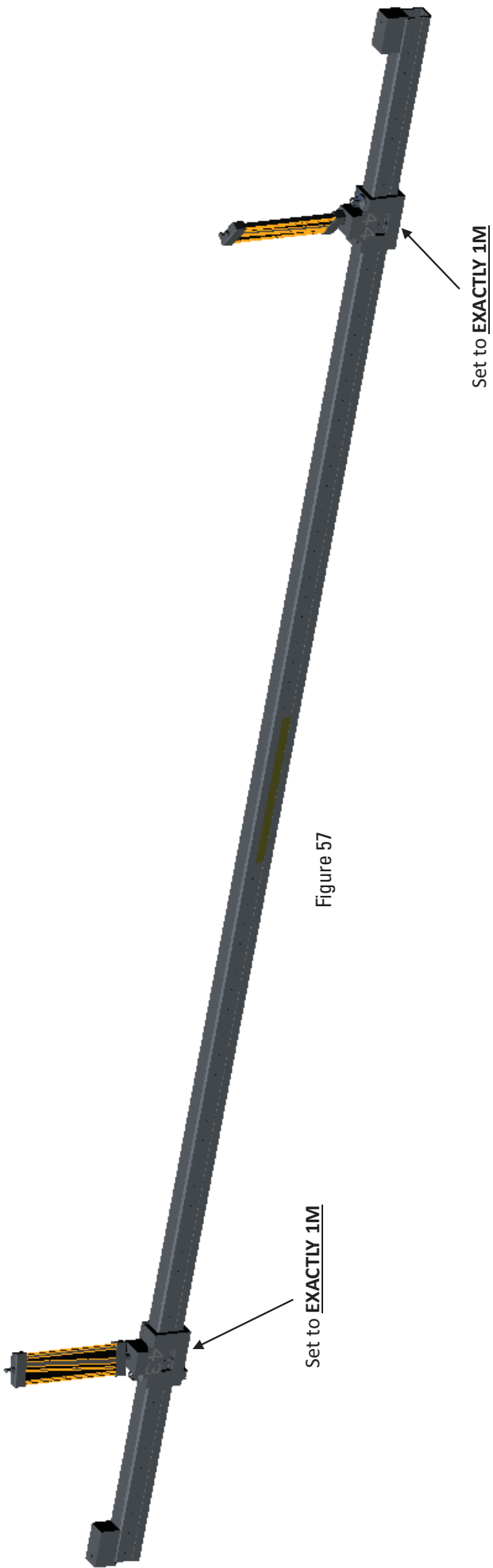
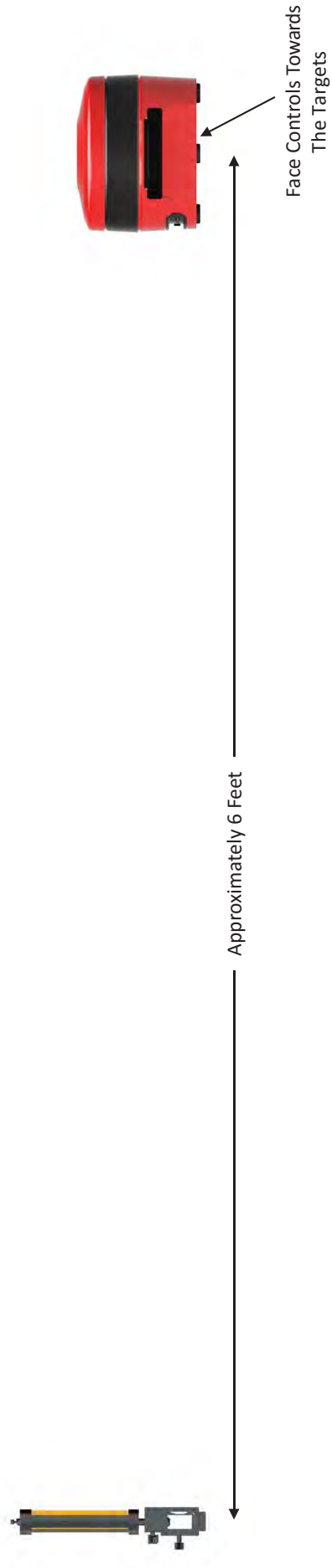

Figure 57



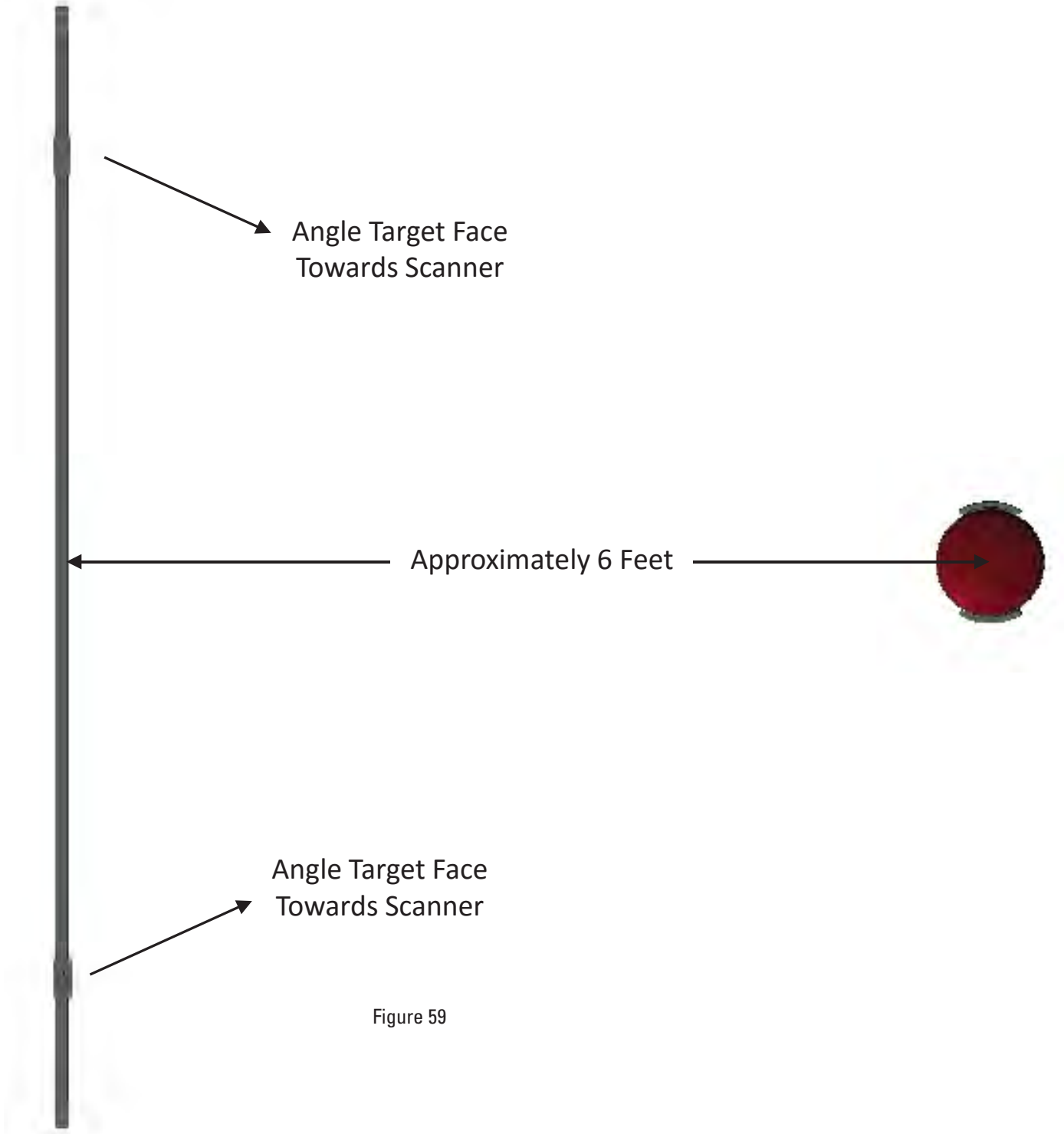
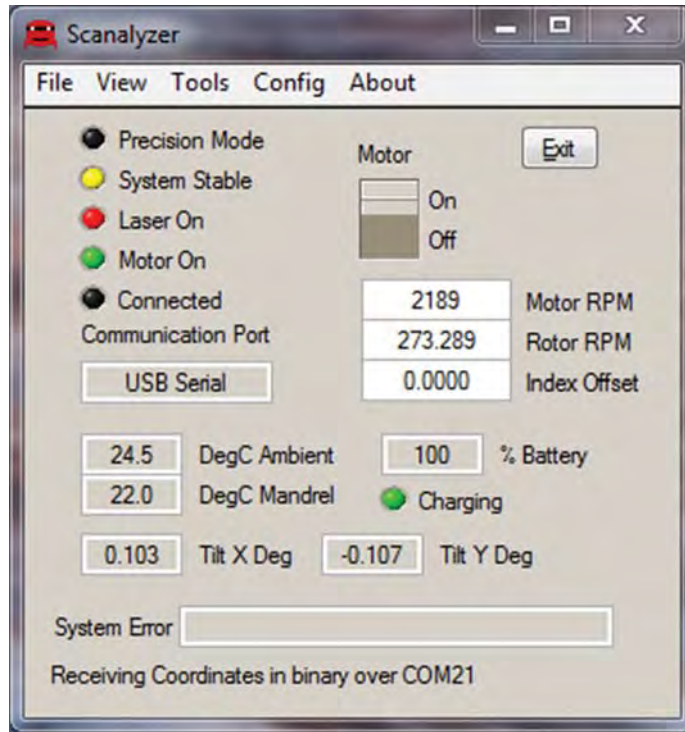
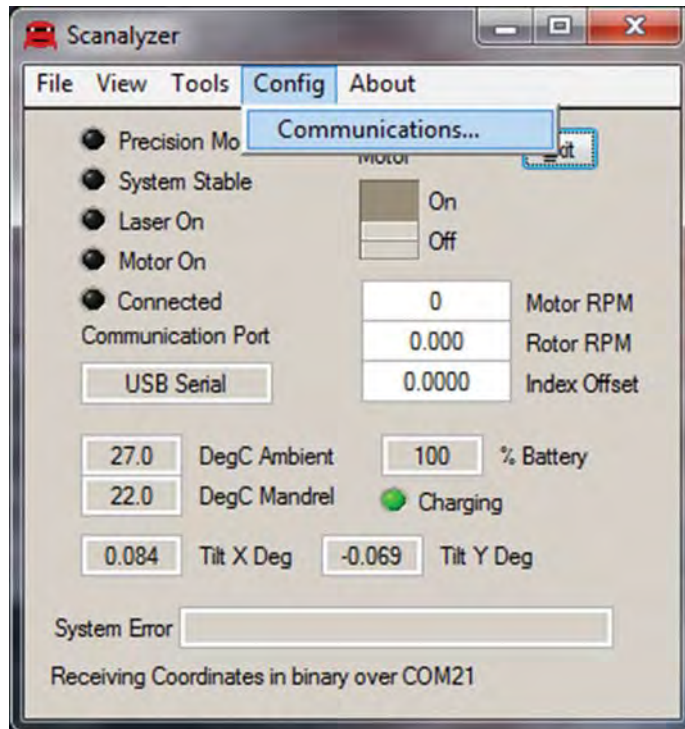

Figure 59

8. Start the Scanalyzer Application from the computer.
9. From the Menu Screen below, select the "Config" option.



10. Then select "Communications" as shown below.



- The select the USB tab shown below, and set the COM Number to the highest number available.

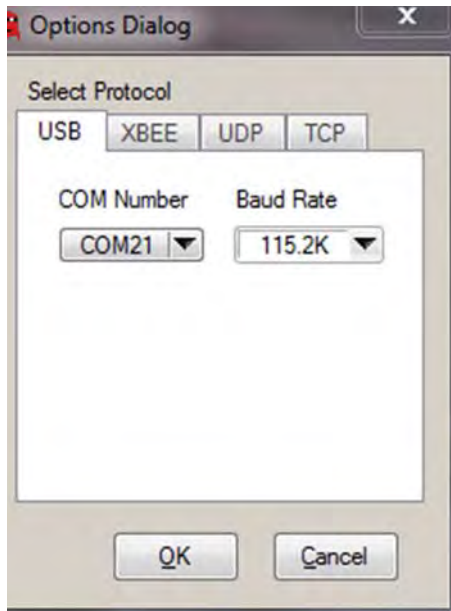

- Then go back to the Main Menu and select the "Tools" option and select "Calibration Check" as shown below.

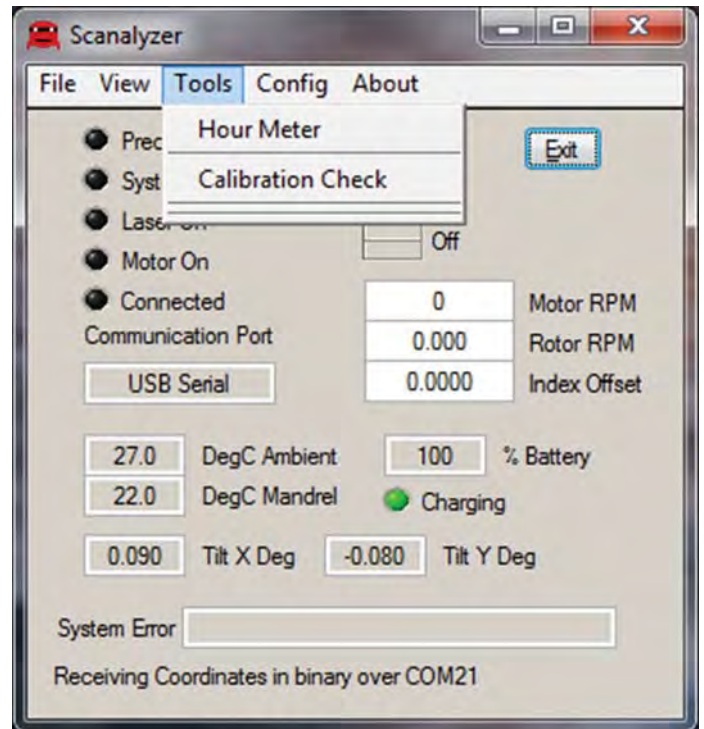

- Turn on scanner motor by selecting motor on button from screen shown below.

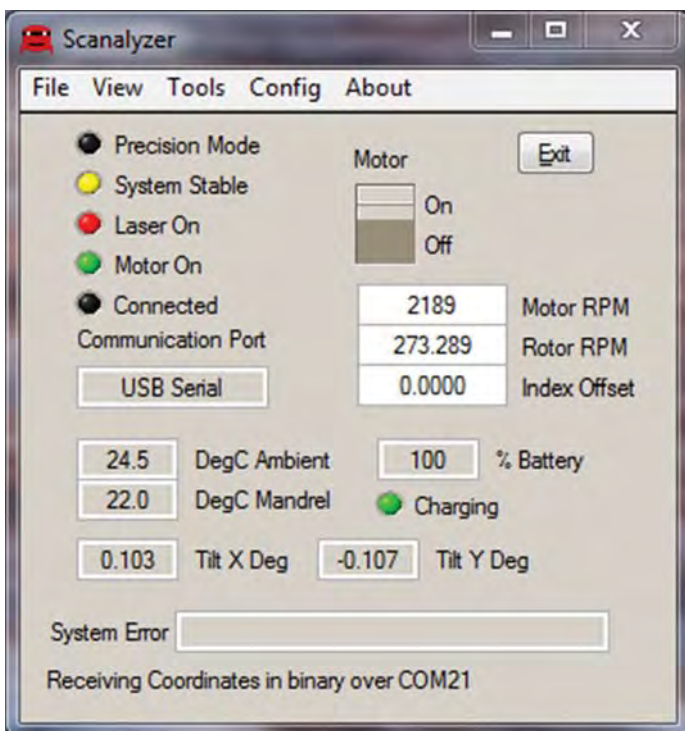

- The calibration should show below. Select the target type you have "Vector" or "Legacy" by clicking on the target picture. Then, if the color box on the bottom of the screen is "Green" then the scanner accuracy is good. If the color is "Red" the scanner accuracy is out of tolerance. The Verification process is now complete.

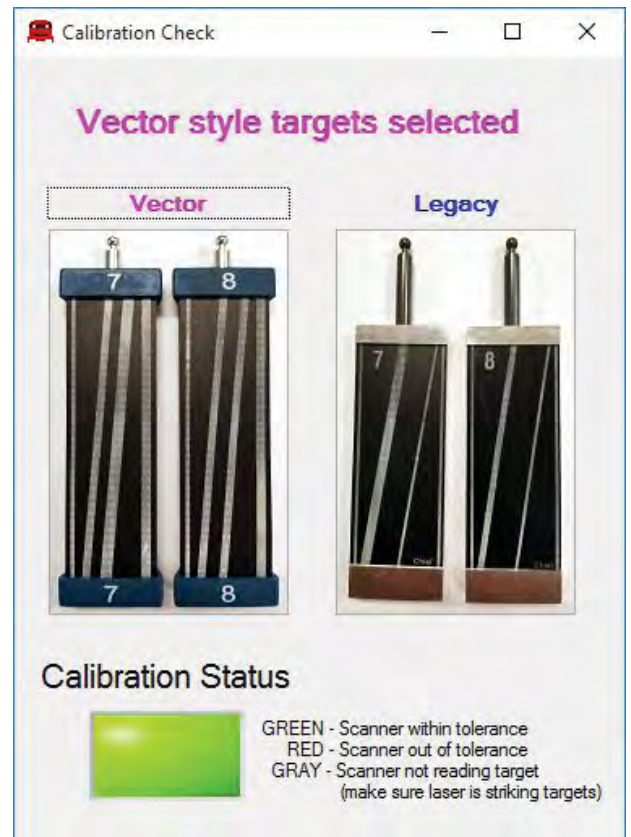

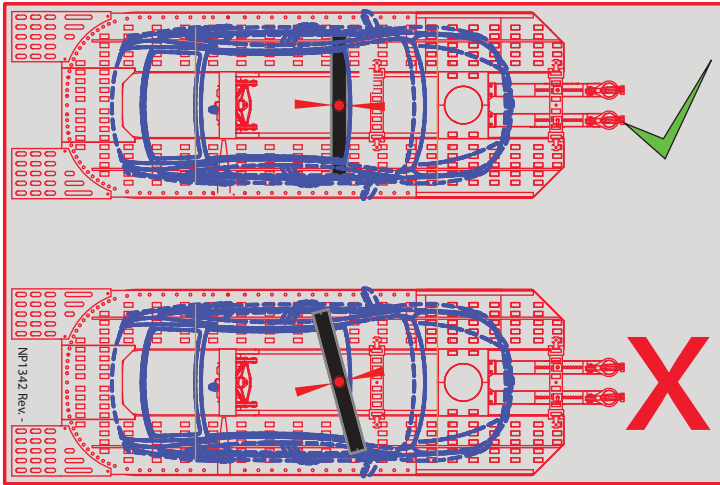
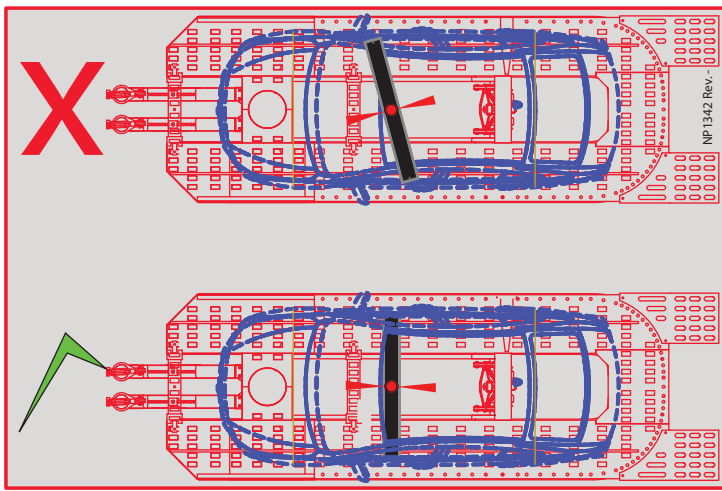

Tray

Please Decals onto ends of scanner tray

Initial Setup: Connecting a Scanner to Genesis Application

1. Connect scanner to computer with USB cable and turn on.
2. Open Genesis Application
3. Select New Measurement

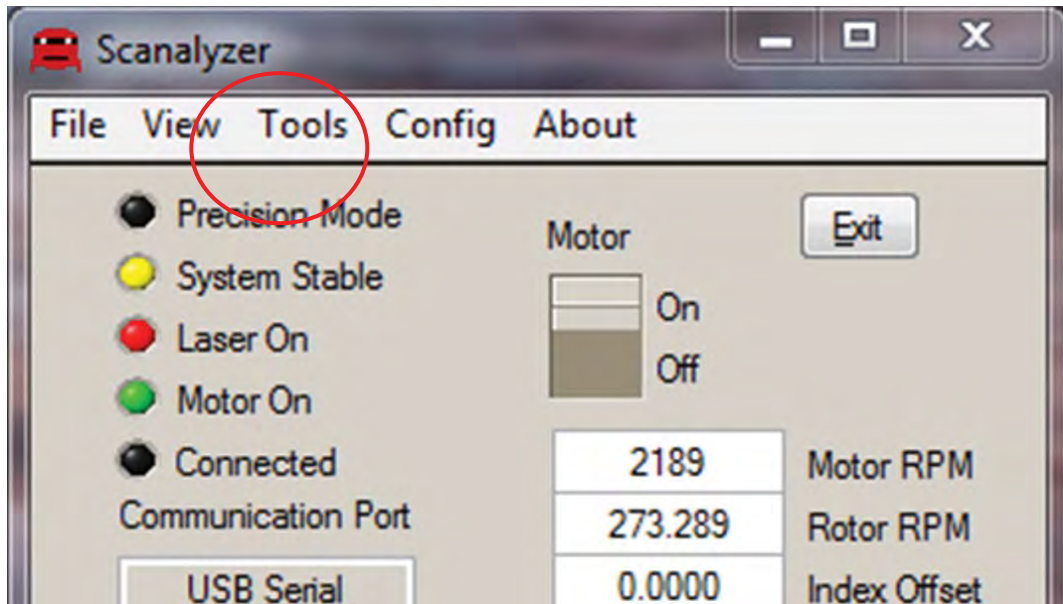

4. Select the vehicle year from the drop-down menu.

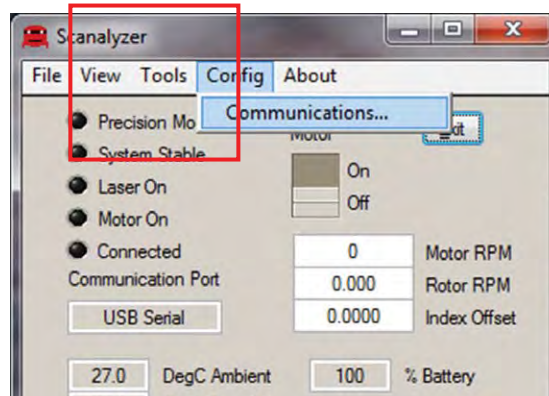

5. Select the vehicle make and click "Next"



Initial Setup: Connecting a Scanner to Genesis Application

6. Select the vehicle model and click **“Next”**

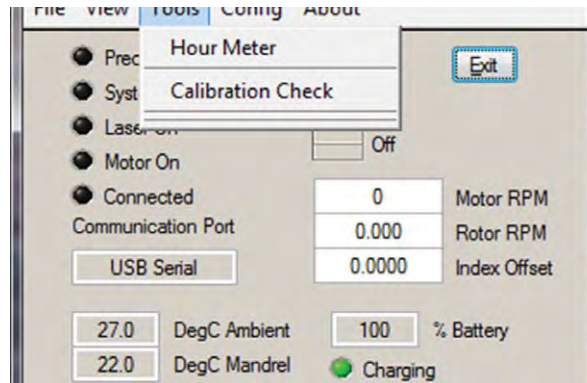

7. Select the vehicle Body Style and click **“Next”**

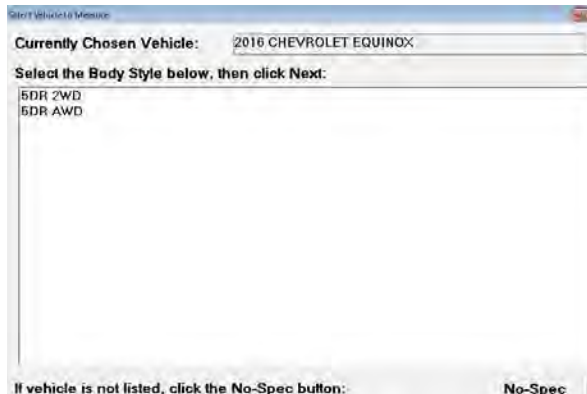

8. On the confirmation screen, select **“Next”**

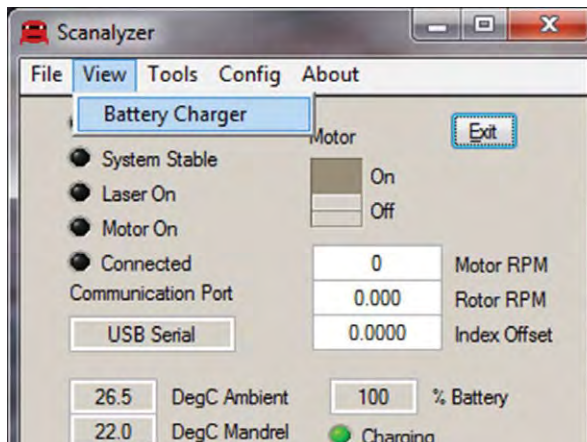

Initial Setup: Connecting a Scanner to Genesis Application

9. Once the measuring window loads, the following popup will appear in the lower right corner of the screen: Select the popup window and proceed to Step 11. If no popup window appears, or if the popup disappears before it can be selected, continue with Step 10.

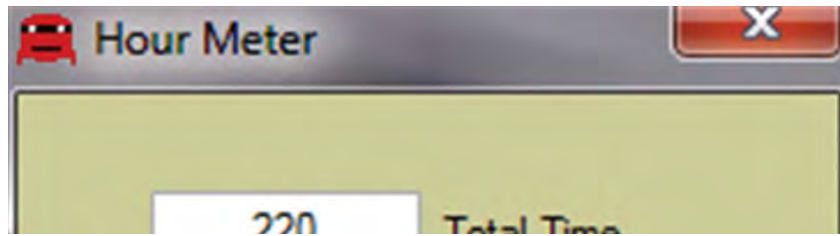

10. On the right side of the Windows taskbar there is a section for notification icons. At the left edge of that section there is an arrow to show all icons. Select the arrow and look for the icon that resembles a Laserlock scanner. Right click the scanner icon, this will open the menu shown in Step 11.

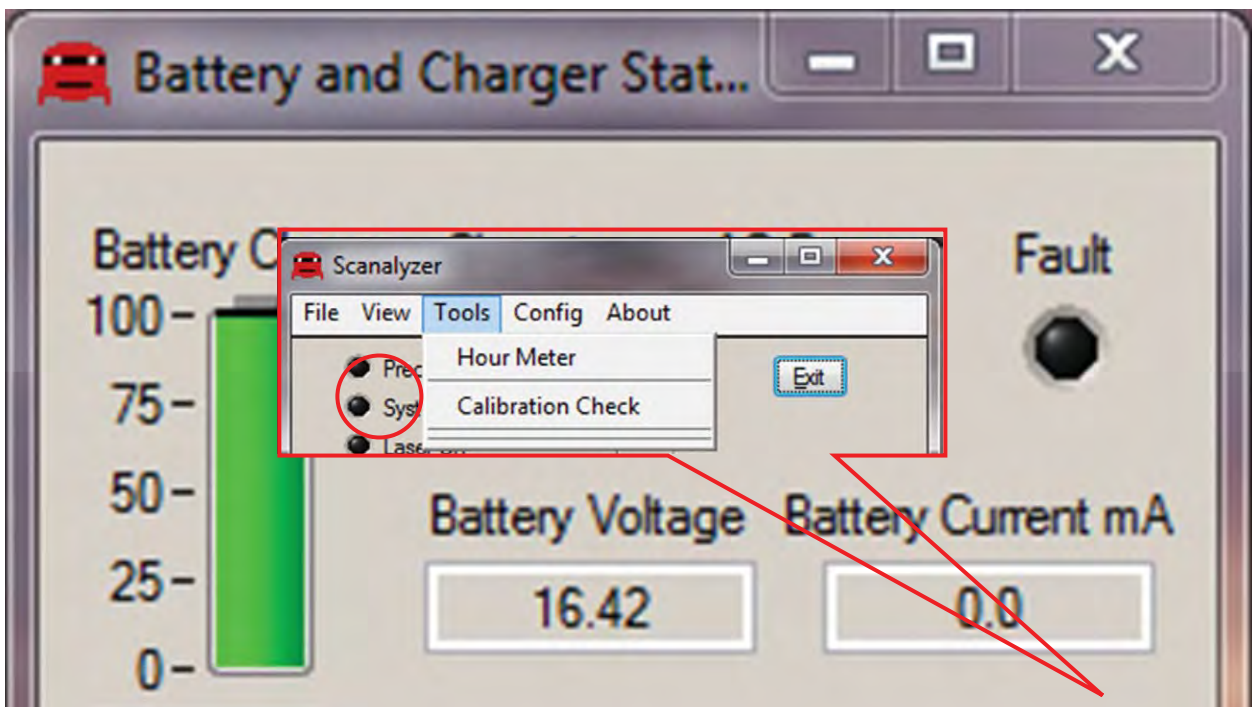

Initial Setup: Connecting a Scanner to Genesis Application

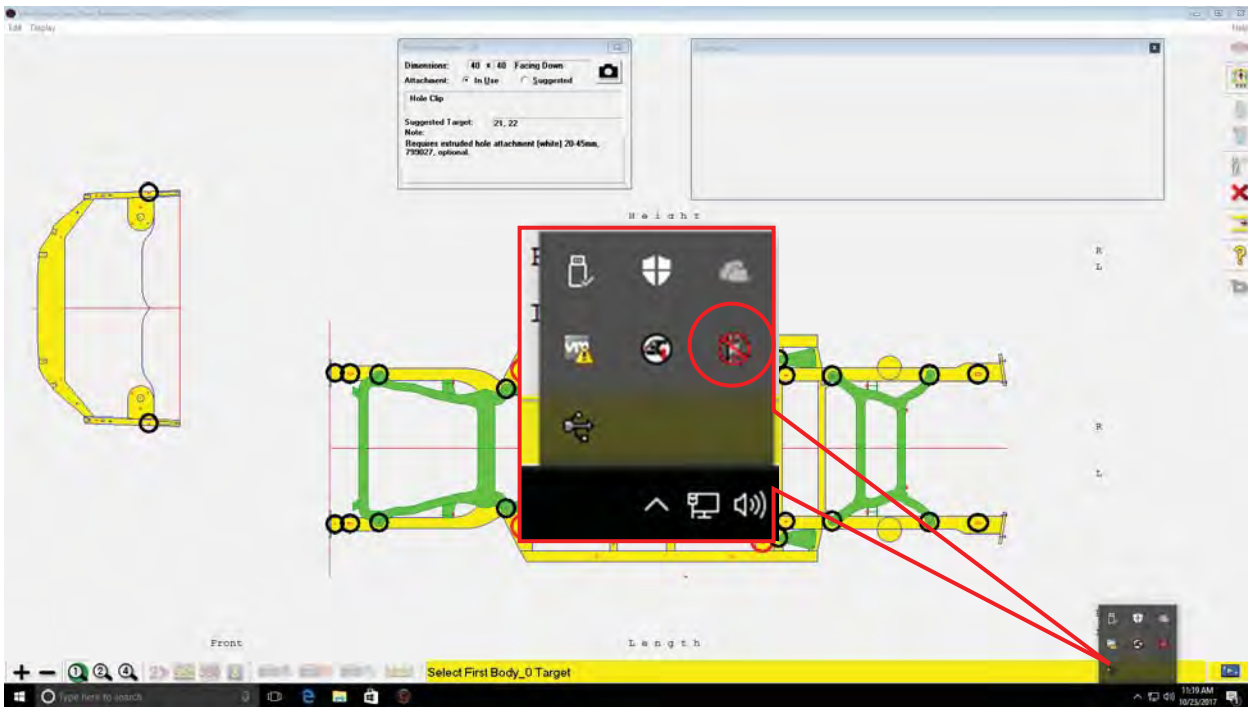

11. After selecting the popup, the following menu will appear in the bottom right hand corner of the screen. Hover over "Port" and select the appropriate communication port from the list. If there are multiple ports listed, hover over each and look for the scanner serial number to appear. Select the port that shows a serial number. If no serial number appears, try the highest port number first. For example, if there is COM1 and COM5 listed, select COM5.

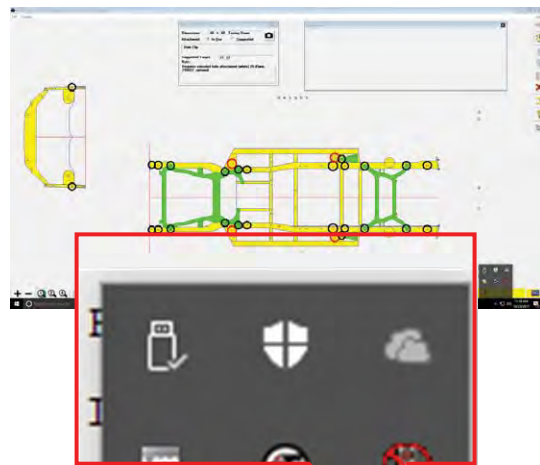
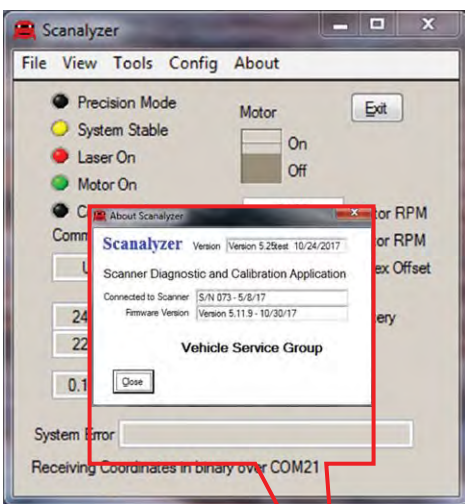

Initial Setup: Connecting a Scanner to Genesis Application

Once the port has been selected, the scanner motor should begin to spin and the laser turn on. If this happens, the scanner has been successfully connected to the computer. If the scanner motor does not turn on, repeat Step 11 in order to select a different port.

Once the scanner has been connected the following popup will appear in the bottom right hand corner showing the scanner as connected. This message box will also display information about the scanner, such as the Serial Number and Firmware Version.

The scanner motor speed has to stabilize in order for Genesis to display consistent accurate measurements. While the motor speed is stabilizing, a message to "Please stand by ..." will appear in the scanner view window. In addition, a thick yellow circle will appear in the center of the scanner. The circle will go to a thin yellow circle, and finally a black circle. While a thick yellow circle and the standby message is displayed, the measure button cannot be selected. Measuring may be done with the scanner showing a thin yellow circle. This message may occasionally display during measuring as well, if the scanner is moved while measuring.

The scanner will remain paired to the computer until a different scanner is connected, or the computer's communication port settings are reset, so this procedure is only required the first time a scanner is connected to the measuring system.

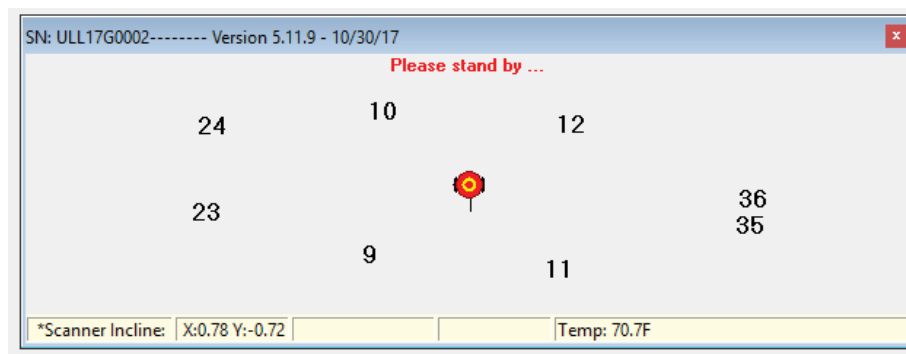
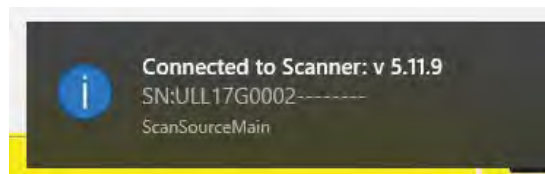

Reconnecting a Scanner to Genesis Application

If for any reason the scanner becomes physically disconnected from the computer during measuring, the following popup will appear in the lower right corner of the screen.

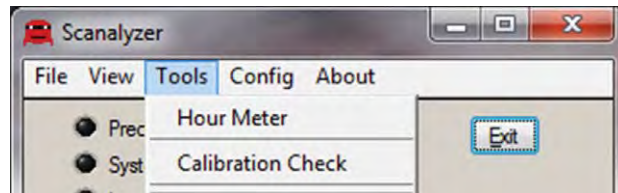

In addition, the scanner view will display a message saying the scanner is not responding.



1. Check to ensure the USB cable is still firmly plugged into the scanner.
2. Check to ensure the USB cable is still firmly plugged into the cabinet.
3. Ensure the scanner has power. If the scanner is showing a green light on the connection panel, then it is receiving power.
4. Once the physical connection has been restored, select the Port Disconnect Error popup to dismiss the message.
5. On the right side of the Windows taskbar there is a section for notification icons. At the left edge of that section there is an arrow to show all icons. Select the arrow and look for the icon that resembles a Laserlock scanner. Right click the scanner icon, this will open the menu shown in **Step 11**.

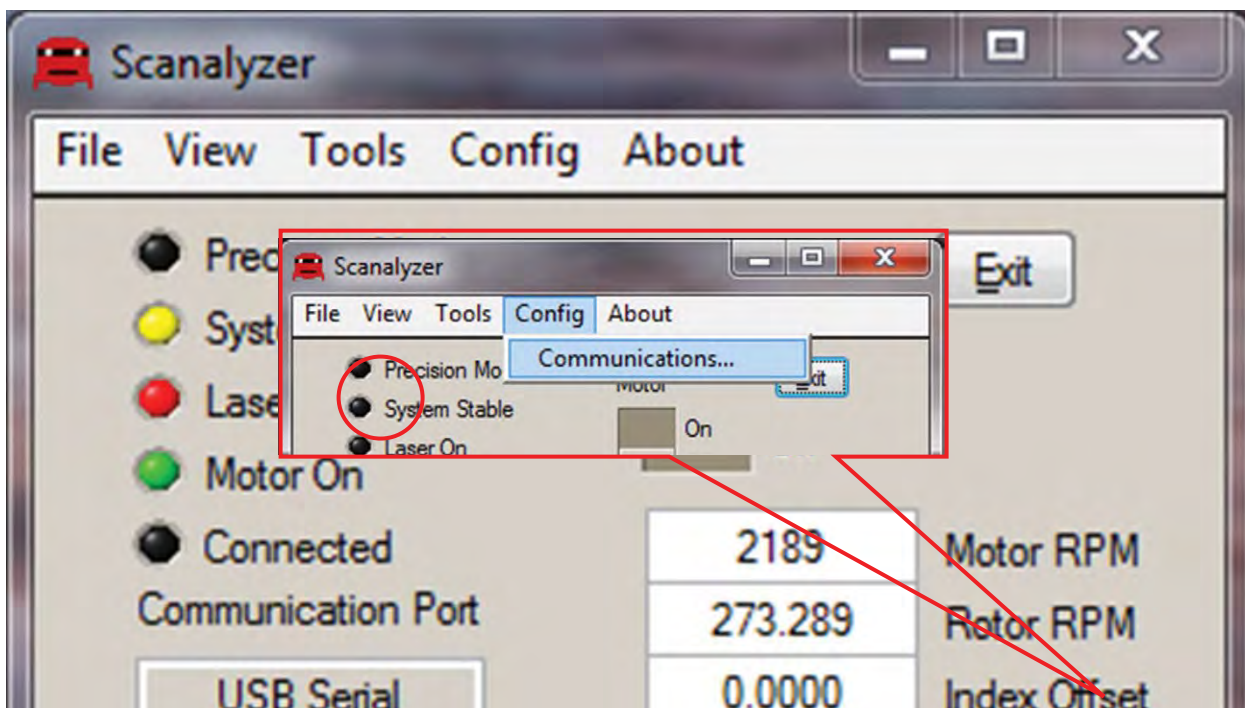

Reconnecting a Scanner to Genesis Application

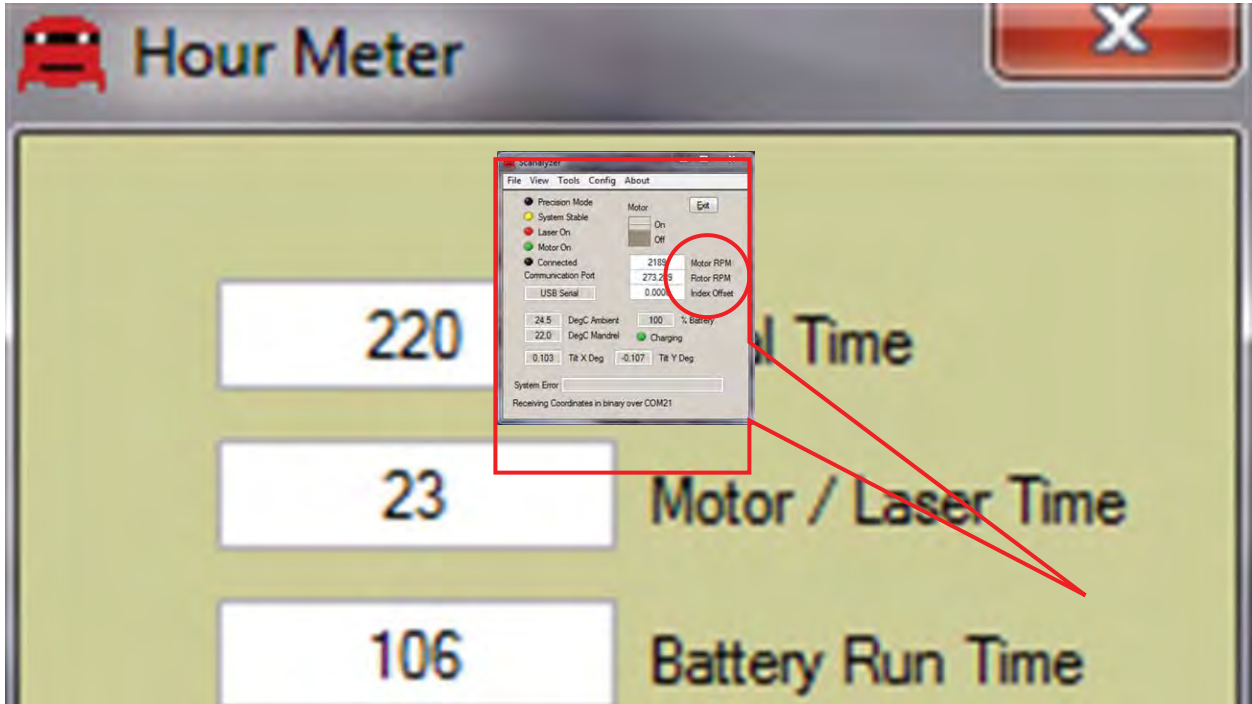

6. After selecting the popup, the following menu will appear in the bottom right hand corner of the screen. Hover over "Port" and select the appropriate communication port from the list.

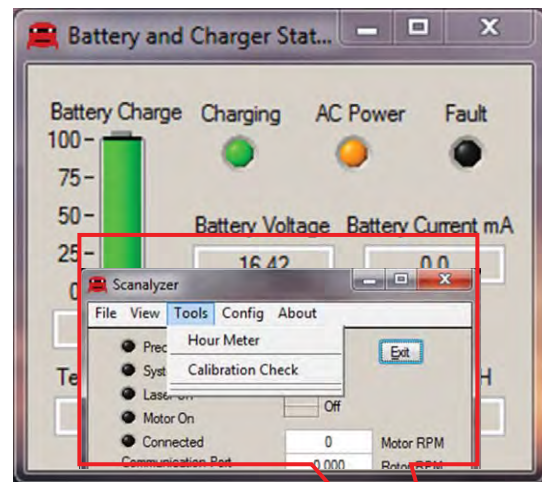
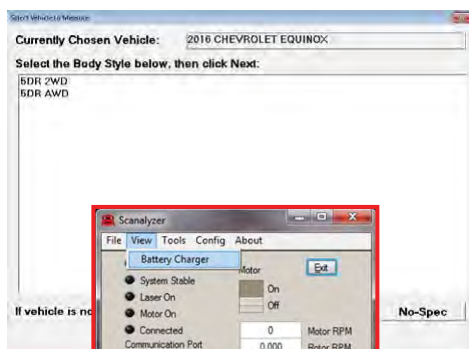

If the scanner is correctly connected to the cabinet and the scanner will not successfully reconnect, please contact Tech Support for further assistance.

Battery (CK720341) Option Installation and Removal Instructions

1. Remove Battery Door from Bottom of Scanner as shown below.

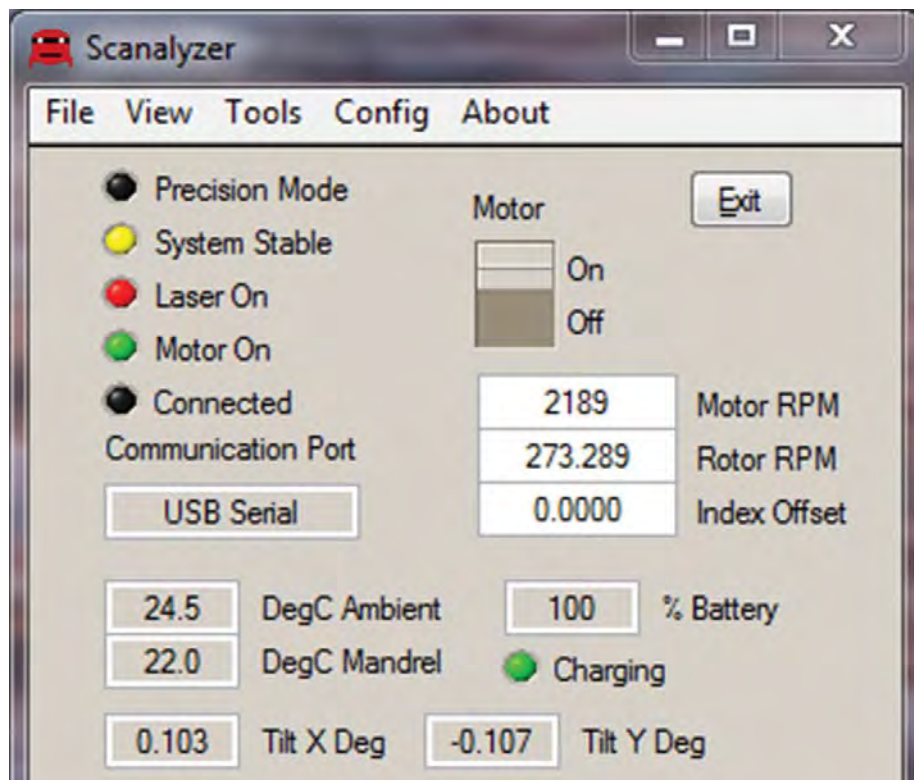

2. Install battery in battery compartment by attaching battery connector to circuit board Harness in scanner. The connector is on the circuit board as shown in pictures below. **It is IMPORTANT to note that the battery connector has a locking tab that must be pressed** as shown in picture below for both installation and removal. Removal of battery is same as installation, just reversed.

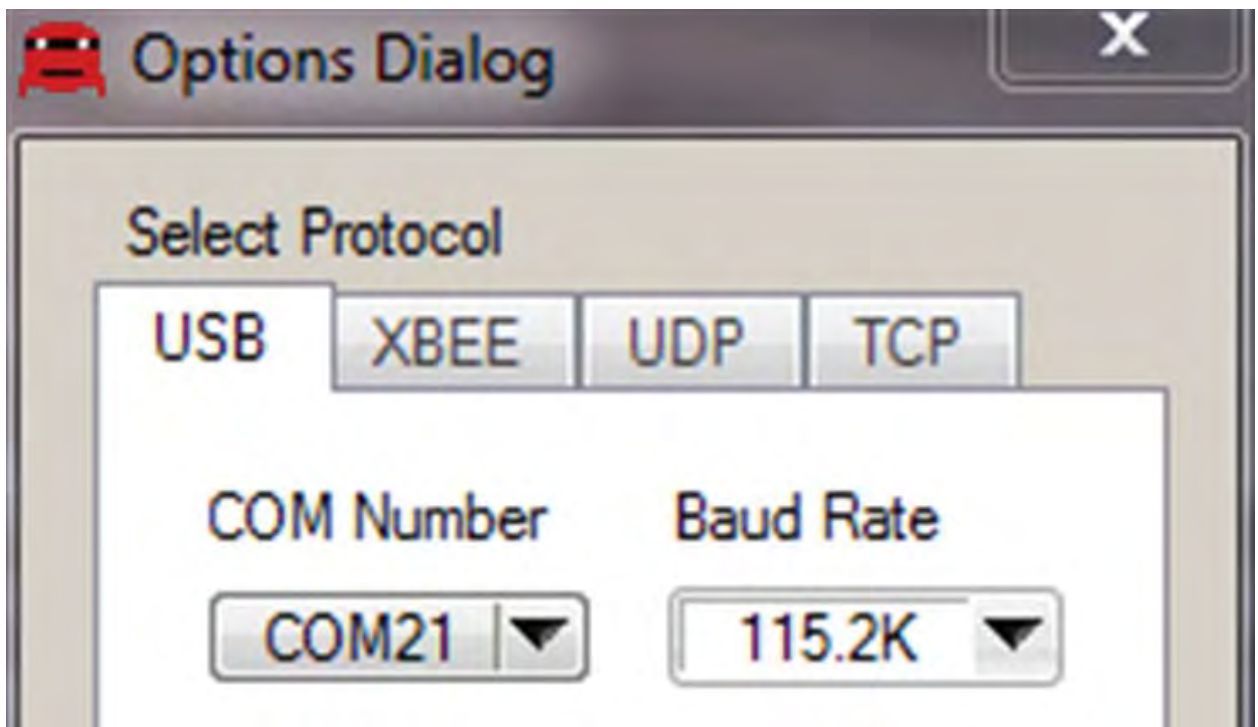
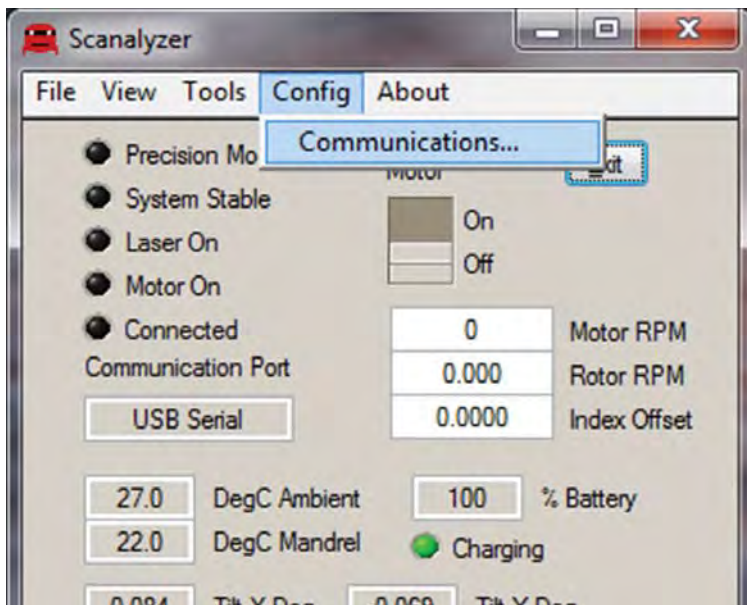

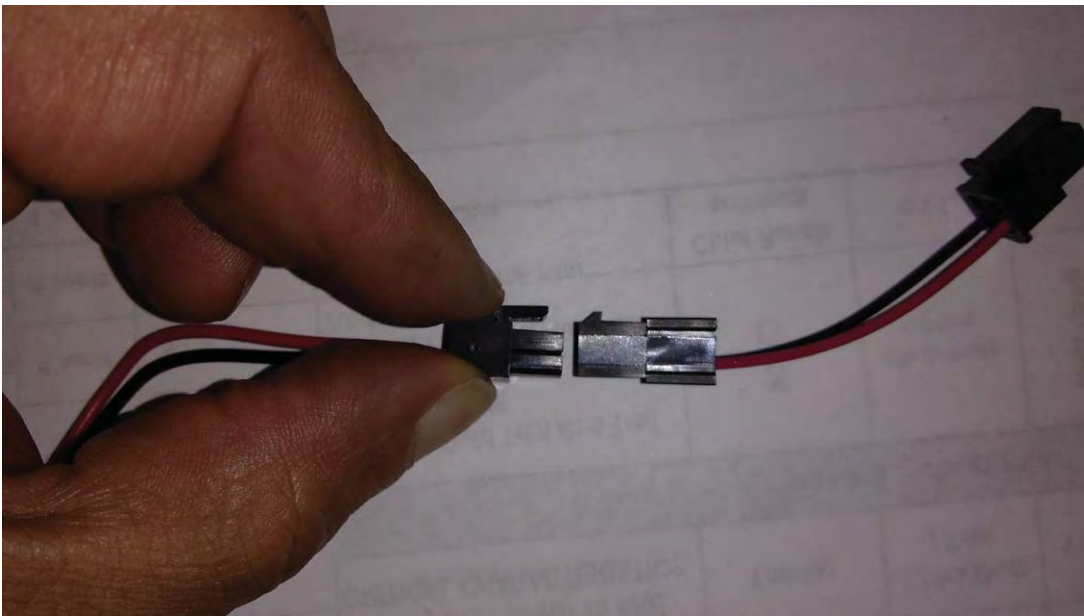
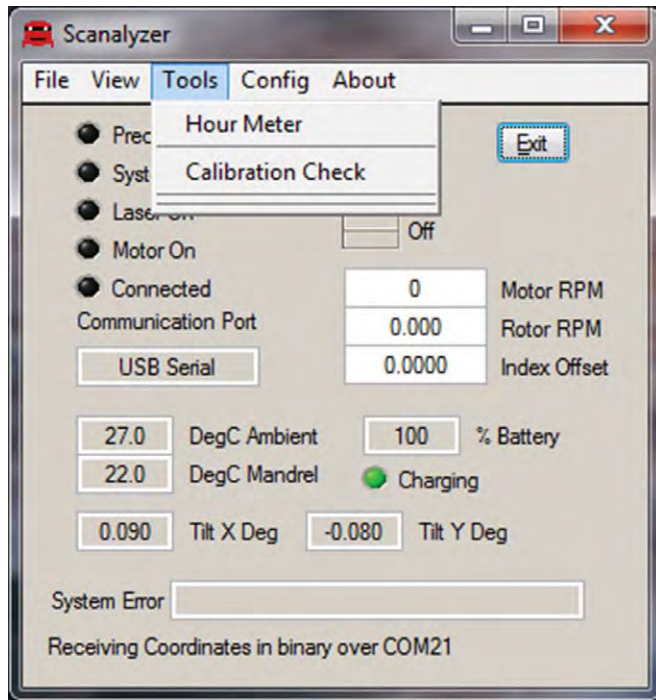

How To Retrieve Troubleshooting Information

1. The Battery Charger (for battery option) window below can also be accessed with the selection of "View" and will display the following information.

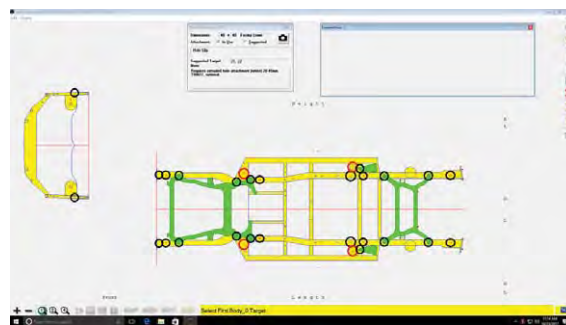
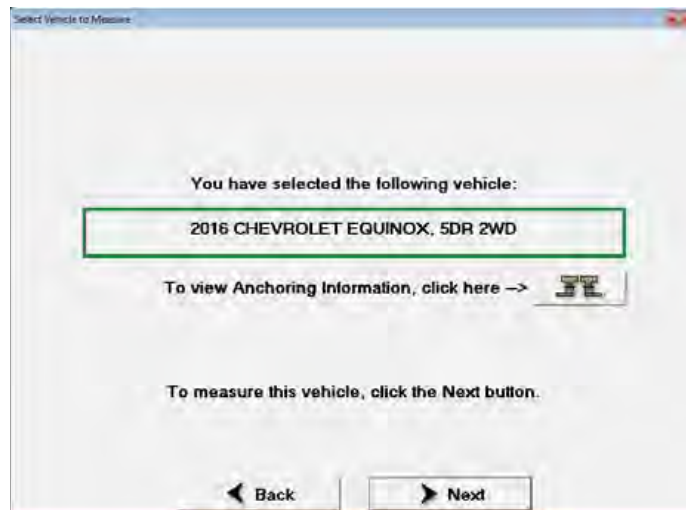

2. The Hour Meter window below can also be accessed with the selection of “Tools” and will display the following information.

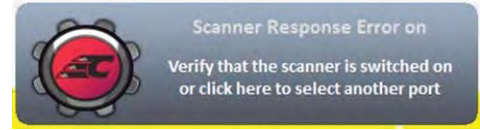
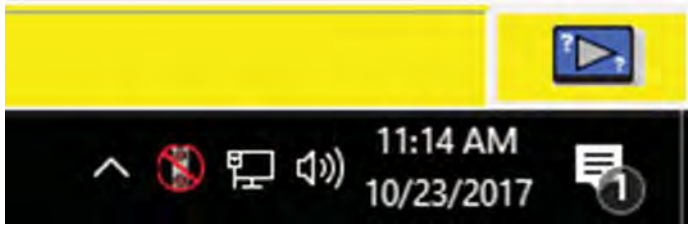

3. Finally, the Scanner Version and incorporated Firmware within the scanner can be determined by selecting the “About” option and the following information will appear.

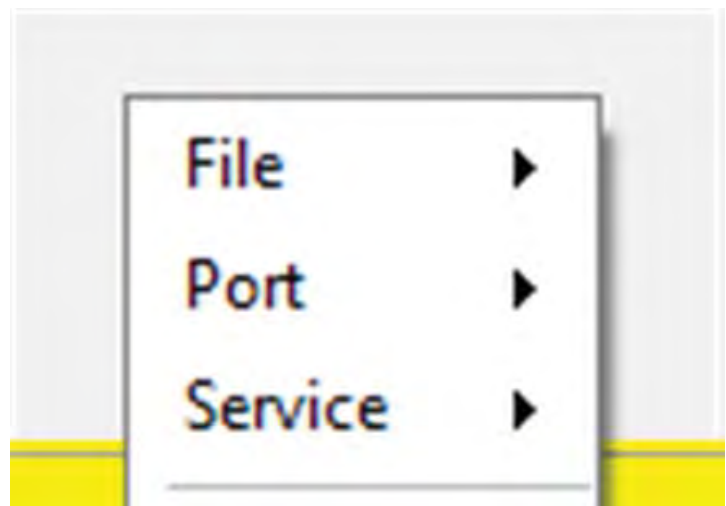
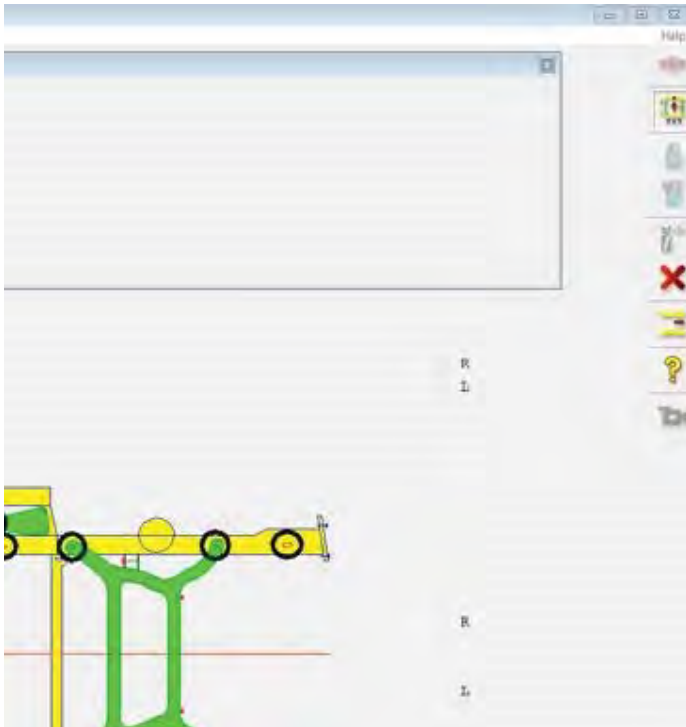

NOTES

NOTES

NOTES



996 Industrial Dr.
Madison, IN 47250
Phone: 800.445.9262
Fax: 866.275.0173

www.chiefautomotive.com

Chief reserves the right to alter product specifications and/or package components without notice.