

LIGNO Acoustic light

Technical data

Applications

Issue 2015-1, last revision on 03/08/2015,
subject to modifications and amendments.

LIGNO Acoustic light timber acoustic elements **for acoustically effective panelling** are used in residential and industrial buildings, e.g. as

- **suspended ceilings** – for example, under wood and concrete structures.
- **wall coverings** – also in front of masonry or concrete
- **acoustic sails** – with edge profiles and light fixtures as acoustic sails freely suspended in the room.
- **grid ceiling** – as cut-to-size panels for insertion into standard system ceilings.

Structure / technical data

The cross laminated timber acoustic panels consist of three layers: Factory slitting of the first layer brings about a batten look on the visible face. The panelling is **ball-impact proof**, appropriate assembly provided. The middle ply (transverse layer) is oriented at right angles to the top layer thus providing for a high degree of dimensional stability. The backside layer in turn is formed by four panels running lengthwise.

Acoustic absorbers are integrated in the transverse layer. Thanks to the recessed absorber material, the panel is **ideal for renovation work** because the absorption effect will not get lost through painting or grinding down. **Surface structuring** achieves additional acoustically advantageous diffuse sound scattering.

- Coverage width: 625 mm
- Type of wood: Spruce / fir (wood moisture content: $9 \pm 2\%$)
- Gluing: PUR adhesive (formaldehyde free), adhesive by weight approx. 1.1 % (triple layer)
- Building material class (DIN 4102): B2. Special version fire class (EN) B-s2,d0.
- Panels can be used in service classes 1 and 2 (timber moisture <20%). Installation locations: **Buildings enclosed on all sides and heated** but also **roofed over, open buildings**, provided the elements are not exposed to the weather. Moisture content equilibrium see page 10.
- Panel structure (cross laminated timber): natureplus® certificate no 0211-0606-014-1, standard absorber from wood fibre: natureplus® certificate no 0104-0710-012-4

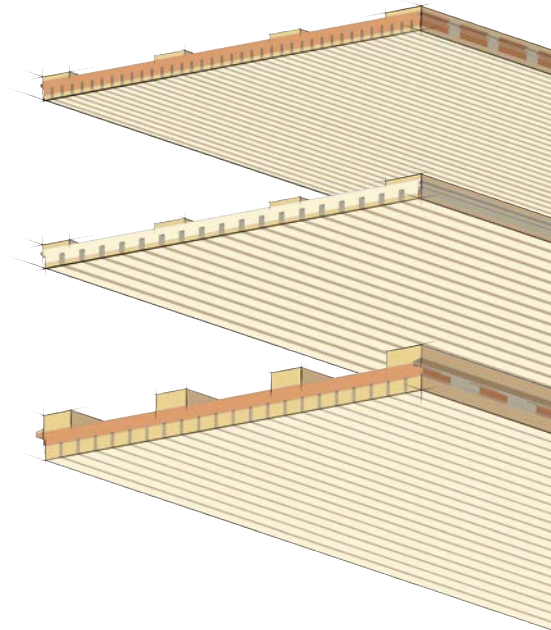

Contents

Applications and suitable element types.....	2
Element configuration and designation	19
Type 3S-33	6
Installation.....	7
Edging.....	11
Inspection openings.....	12
Impact walls.....	13
Grid ceilings, acoustic canopies	14
Type 3S-62	15
Installation.....	16
Surface (wood types).....	18
Low flammability.....	19
Final treatment	20
Acoustic profiles.....	21
Acoustic absorption properties.....	22
Element weight.....	26
Green building	26
Checklist material and tools.....	27
Processing guidelines.....	28



Information and references online
www.lignotrend.com/akustik-light

Application range and suitable element types

Application D1: Ceiling panelling / element installation in the stretching bond

Use of elements in standard length
2,920 mm

Notes:

- Frontal butts are identifiable on the surface.
- Little offcut: The section of the last element is being used as the first element in the next row each time.

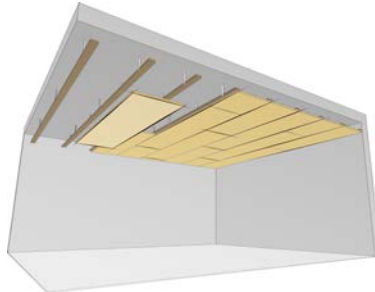

Element selection:

- Normally inflammable 3S-33 ▶ Page 6
- Hardly inflammable B-s2,d0 to DIN EN 13501-1 3S-33, surface impregnated ▶ Page 6, information on page 19

Select for extended requirements...

- For individual / larger element length: Type 3S-62 ▶ see application D2

Application D2: Ceiling panelling / elements in individual length

Use of individually produced elements in continuous lengths ranging up to 8,000 mm, hence no frontal element butt on the building site.

Notes:

- Weight of longer elements can make the assembly difficult.
- The elements should be ordered a bit longer to be adjusted to the exact measurement on the building site.

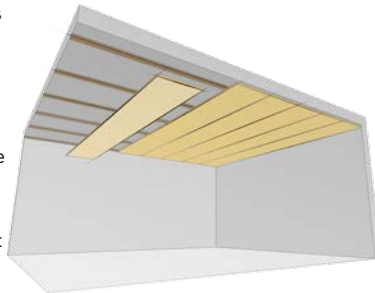

Element selection:

- Normally inflammable 3S-62 continuous production ▶ Page 15

Application D3: Ceiling canopy

LIGNO Acoustic light is available as ready assembled, free-hanging ceiling canopy with circumferential metal frame and with integrated workplace luminaire as an option.

The canopy is suspended on wire ropes or in groups, hence free circulation of air (important in thermal activation of concrete ceilings)



Element selection:

- Normally inflammable 3S-33 ▶ Page 14
- Note: Canopies are delivered fully configured

Application D4: Grid ceiling

Readily cut pieces of LIGNO Acoustic light panels can be fit into existing grid ceiling structures..

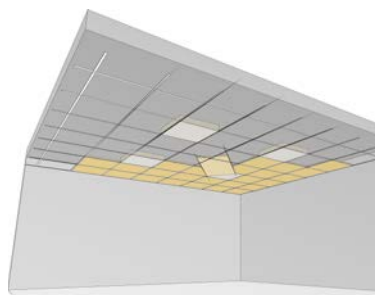

Element selection:

- Normally inflammable 3S-33 ▶ Seite 14
- Hardly inflammable B-s2,d0 to DIN EN 13501-1 3S-33, surface impregnated ▶ Page 14, information on page 19

Acoustic ceiling in a hotel's
wellness area

Surface:
Silver fir, knotless, patterned
Profile 625-12-4
Braced installation



Acoustic ceiling for a gymnasium
(Design: City of Stuttgart
Building department)

Surface:
Silver fir, knotless, patterned (B-s2,d0)
Profile 625-25-8
Individual element length



Ceiling canopy in a fitness studio
(Design: Robert Lassenius, Berlin)

Surface:
Silver fir, knotless, patterned
Profile 625-12-4

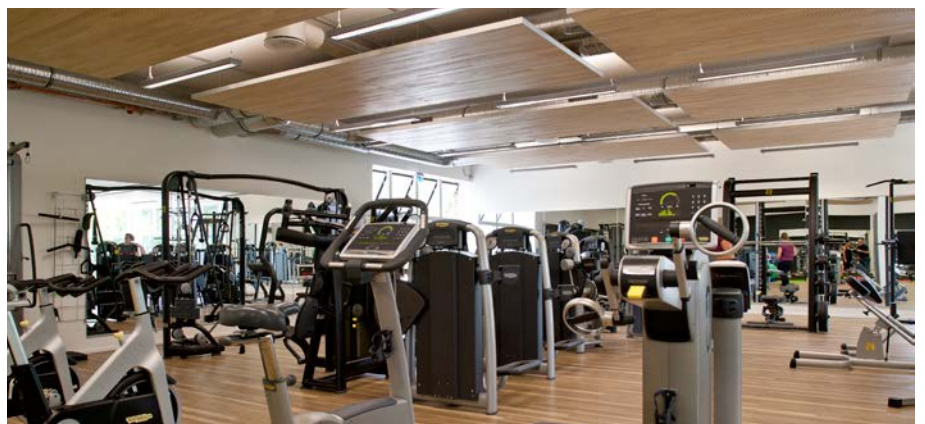

Workshop

Surface:
Silver fir, knotless, patterned
Profile 625-12-4
Grid ceiling

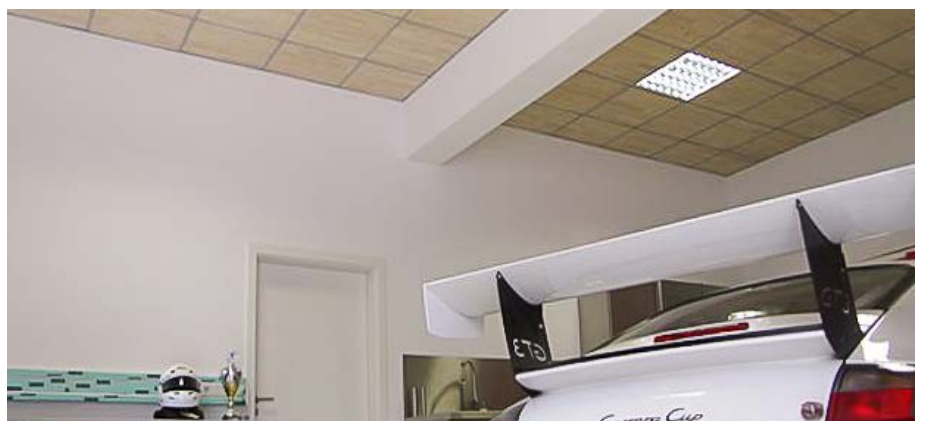

Application W1: Wall panelling / element installation in the stretching bond

Use of elements in standard length 2,920 mm

Notes:

- Frontal butts are identifiable on the surface.
- Installation with vertical or horizontal gap pattern.
- Little offcut: The section of the last element is being used as the first element in the next row each time.

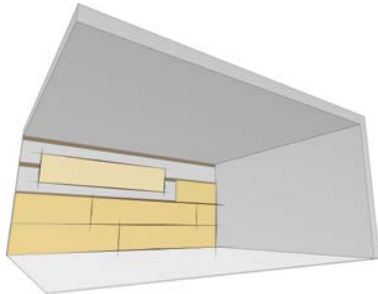

Element selection:

- Normally inflammable 3S-33 ▶ Page 6
- Hardly inflammable B-s2,d0 to DIN EN 13501-1 3S-33, surface impregnated ▶ Page 6, information on page 19!

Select for extended requirements...

- For individual / larger element length: Type 3S-62 ▶ see application W2

Application W2: Wall panelling / elements in individual length

Vertical and horizontal installation of individually produced elements in continuous lengths ranging up to 8,000 mm, hence no frontal element butt on the building site.

Notes:

- Weight of longer elements can make the assembly difficult.
- The elements should be ordered a bit longer to be adjusted to the exact measurement on the building site.

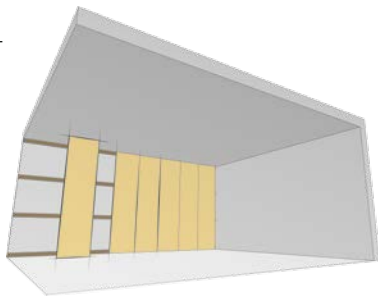

Element selection:

- Normally inflammable 3S-62, continuous production ▶ Page 15

Application W3: Impact wall, acoustically effective

Fitting of elements on special, force-reducing substructure (elastic brace and counterbrace configuration, force reduction checked).

Installation with horizontal joint pattern.

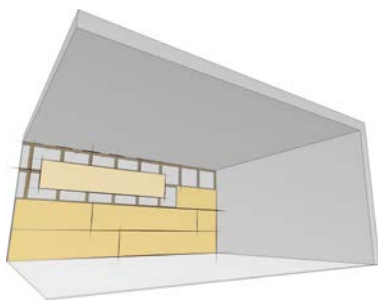

Construction:

▶ Page 13

Element selection:

- Normally inflammable 3S-33 ▶ Page 6
- Hardly inflammable B-s2,d0 to DIN EN 13501-1 3S-33, surface impregnated ▶ Page 6, information on page 19!
- Normally inflammable 3S-62, continuous production ▶ Page 15

Wall covering in an office
(Arch.: phase2 architecture, Berlin)

Surface:
Silver fir, knotless, plain
Profile 625-12-4
Braced installation

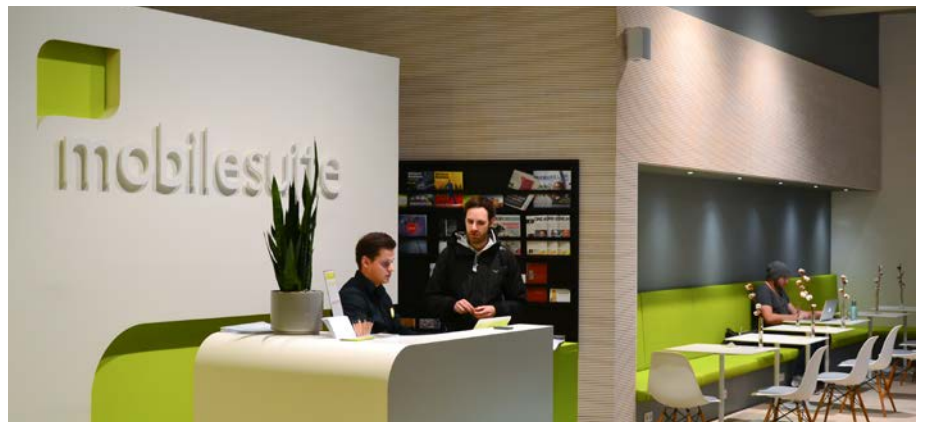

Interior finish of a canteen

Surface:
Silver fir, knotless, patterned
Profile 625-12-4



Impact walls and acoustic ceiling
in a sports hall
(Arch.: Harter + Kanzler, Freiburg)

Surface:
Silver fir, knotless, patterned
Profile 625-12-4
(Ceiling 625-24-8)



Renovation of indoor aquatic centre

Surface:
Silver fir, knotless, patterned
Final treatment W10 and red
Profile 625-12-4



Type 3S-33 Geometry

Application

See pages 2-5

Availability

- only in standard length 2,920 mm
- with normally flammable surface, with profiles 625-12-4, 625-21-4 and 625-nature-4 also with low inflammability B-s2,d0

View:

Timber ledge profile

Wood types and profile alternatives ► from page 18

Absorber type A70G

Approx. 70 % absorber portion in the transverse layer, absorber: Wood fibre

Lateral section:

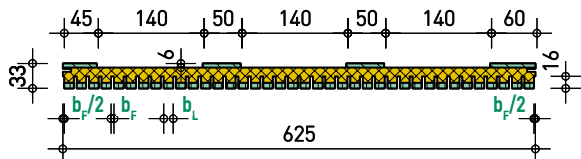

Longitudinal section:

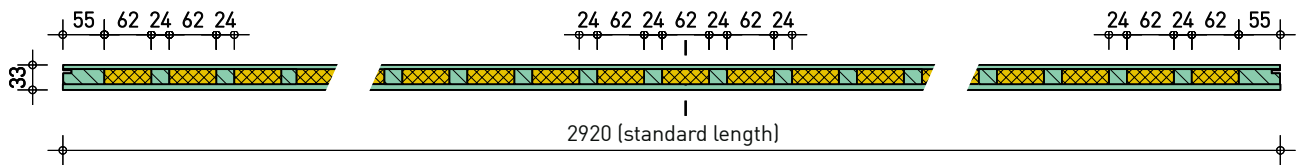

Information on tolerance regarding elements' internal structure:

With constant total thickness of the element, the thickness of the visible and the rear layer can vary by approx. ± 0,5 mm. Also, the position of absorber strips and timber transversal layer can vary in the range of millimetres for production-related reasons.

Standard edging:

Circumferential groove, matching plywood tongue is included

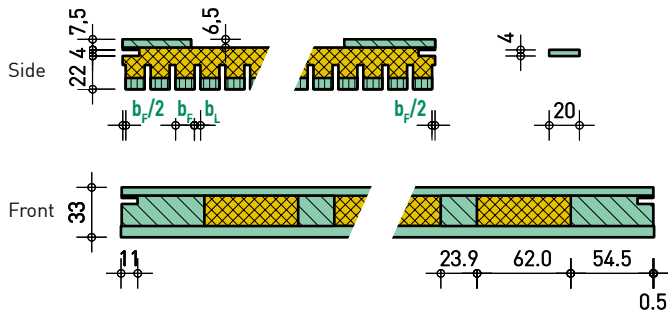

Edging NF:

Groove and tongue joint circumferential (please state when ordering!)

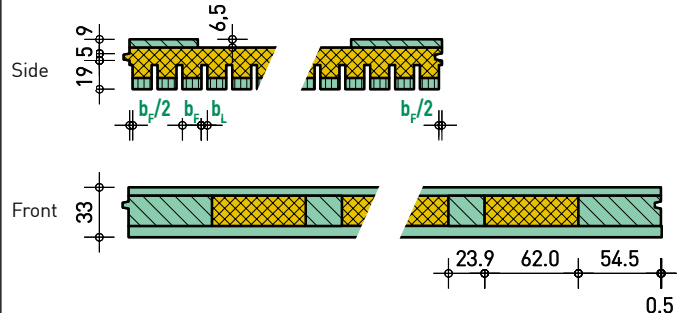

Variant R0 ('reflecting')

Rigid transverse layer with relieving strip (wood fibre)

Lateral section:

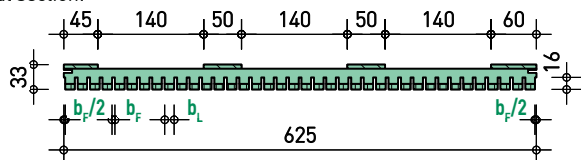

Longitudinal section:

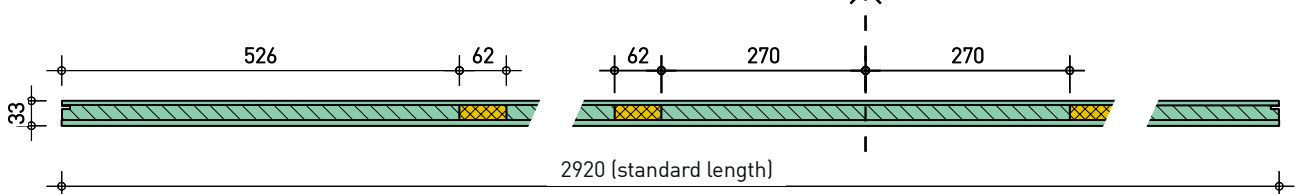

Note: Higher weight! ► see page 26

■ Type 3S-33 Installation

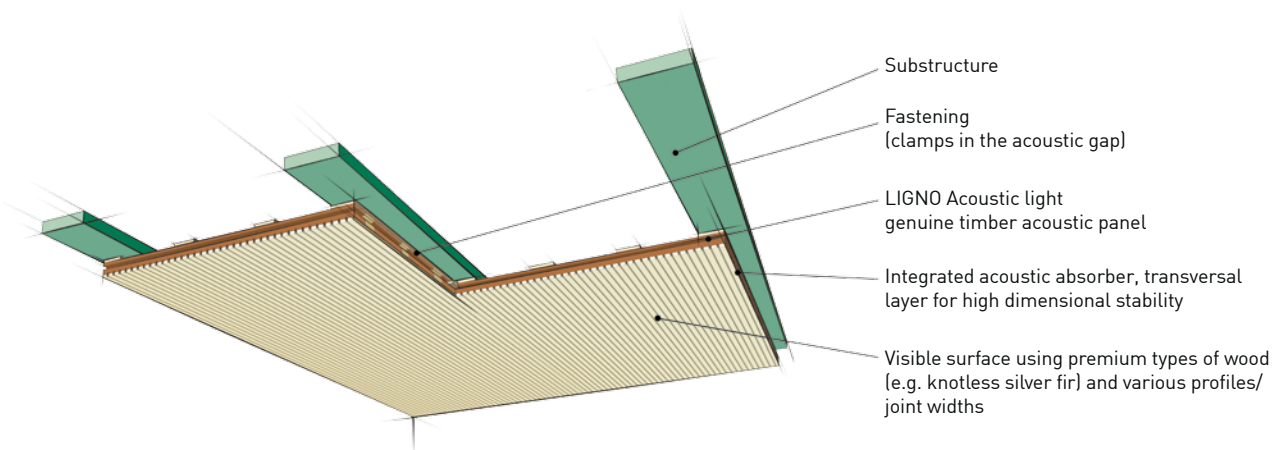

1. Substructure

- Elements LIGNO Acoustic light of type 3S-33 are in standard installed on a **substructure running parallel to the elements' length**.
- Material for substructure:
Wooden batten (rectangular section): min. 30/100 mm, pitch 625mm, stripes of 3-ply-panels recommended.
- Also place substructure around openings and alongside the edges of the wall/ceiling.
- Only use connectors approved for the building structure's material!
- Exactly level the substructure's lower edge horizontally.

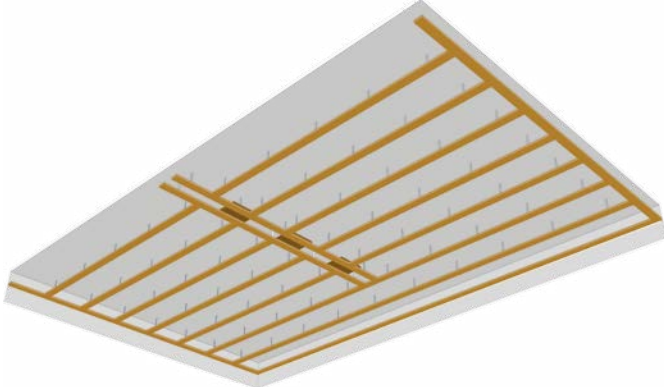

- Installation substructure directly to the building structure, Line if necessary (e.g. for reason of structure's unevenness).

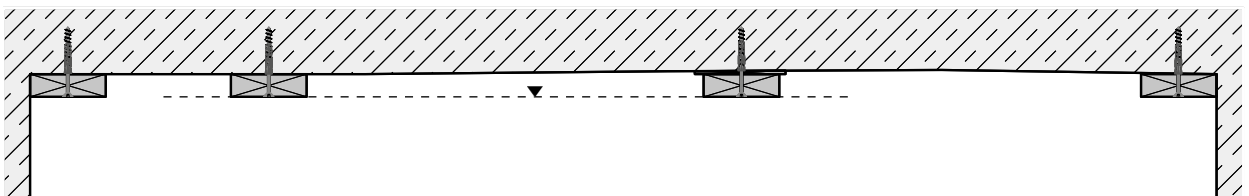

- Alternative: Installation of substructure with suspension system suitable for wooden battens, e.g. two-piece "Nonius" type metal suspending brackets with bottom part designed for screw-on fixing on wood. Mind the manufacturer's specifications!

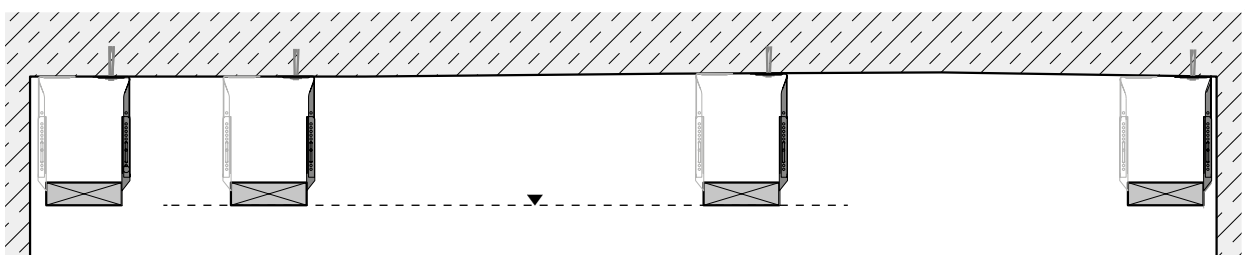

■ Type 3S-33 Installation

2. Element installation, first rows

- Prepare all cuttings on the ground, also openings for components to build in.

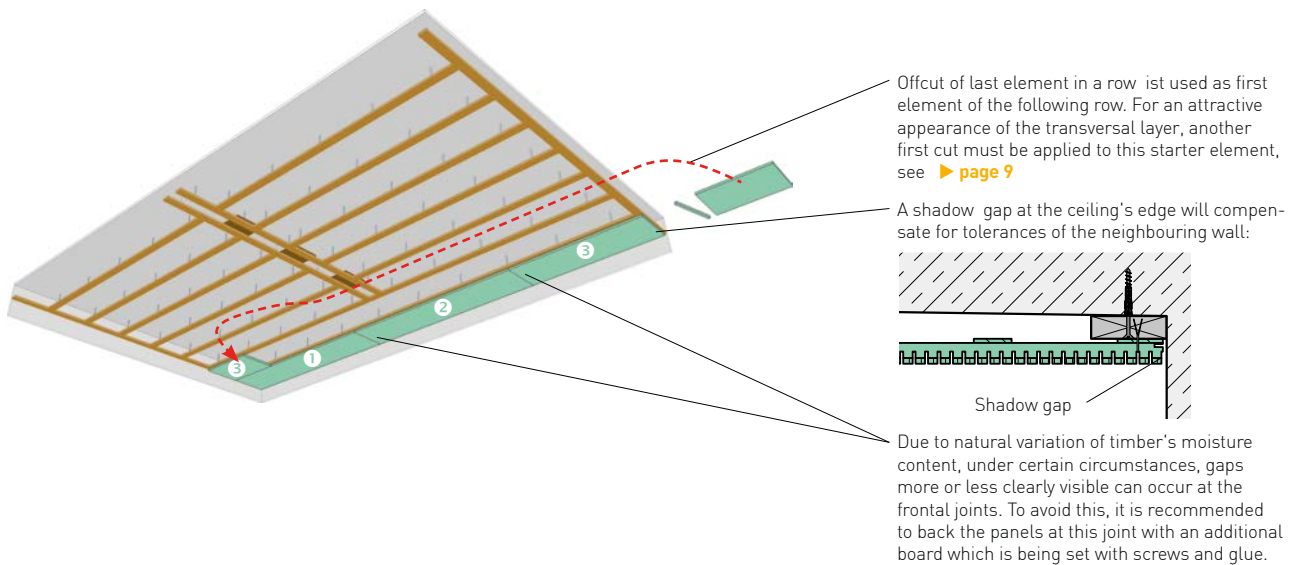

- All connection material must be applied in line with the elements' intermediate transversal layers' axis which is visible through the acoustic gaps, application of any fasteners through the wood fibre absorber is not allowed!**

- Standard fastening with clamps / nails
(concealed, in the acoustic gaps)

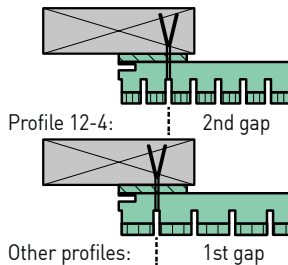

- Appropriate compressed-air staple gun: Klammer-Nagler K.M. Reich, type 3428 with foot for Lignotrend-acoustic panels, available from Lignotrend (also to be leased).
- clamps type G, approx. 10 pcs. per panel (dependent on load, in doubt provide proof)
- Observe the edge distance on the element:
Clamp in the second edge gap when using profiles with 12 mm ledges!

- Alternative fastening with special screws
(concealed, in the acoustic gaps)

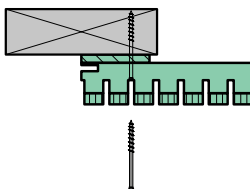

- Use a self-drilling fully-thread screw 3.5 x 40 (V4A) with narrow head, approx. 10 pcs. per panel, special screws and suitable inserts (bits) with prolonged tip are available from Lignotrend).
- Using screws in the gap lets them almost completely disappear from view.

- Alternative fastening with screws applied in the elements' joint zone
(Special elements NF with tongue and groove joint necessary!)

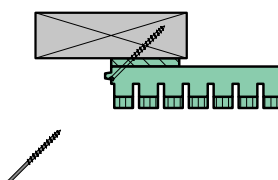

- Fastening in the zone of tongue joint using a diagonally set self-drilling fully-thread special screw, 3,5 x 40 (V4A) or partial-thread screw, e.g. 4 x 50, approx. 8-12 pcs./ panel.
- First and last element row to be fixed through an acoustic ledge or with special screws in the gap, see above.

3. Cuttings

- **Look out for sharp tools!**
- Straight sections: Use circular saw and rail
- Openings: Use a drill bit tube or jigsaw. **Secure Ledges against breaking off before drilling!**

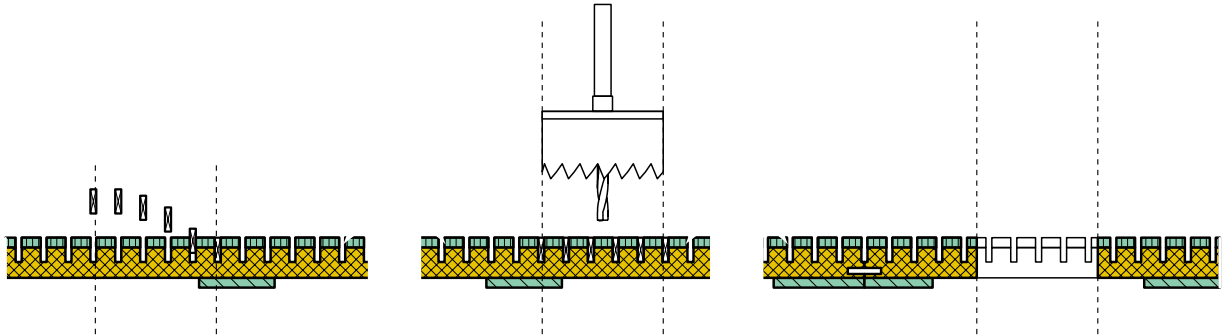

- **Check approval for installation in timber panels before installation of any parts, especially electric components as lamps. Always refer to manufacturer's specifications!**

4. Element installation, further rows

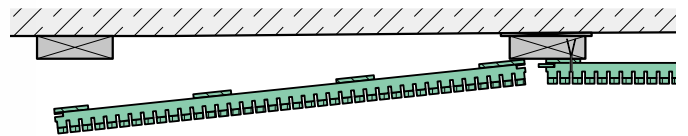
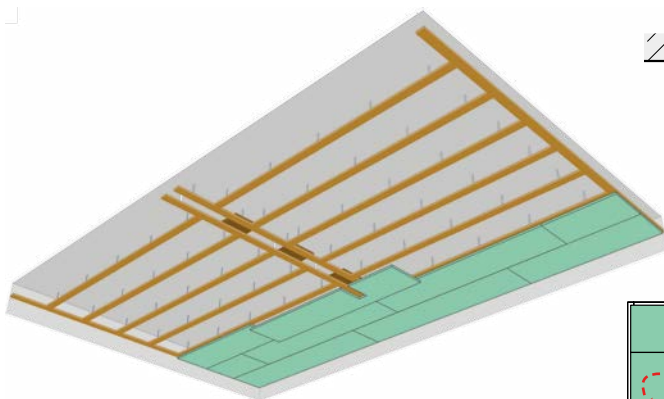

- Normally, the elements are installed in the stretching bond: The last offcut piece of a row is being used as starting piece of the following row.
- Note for wall panellings and other panellings with acoustic gaps of more than 4 mm width: In case of unfavourable lighting conditions, the transversal layers behind the gaps can be recognisable. To accomplish a good appearance of the lateral joint, you should mind to have the transversal layers of adjoining elements aligned.

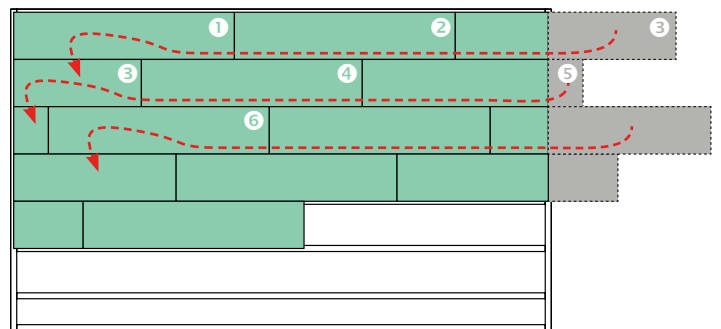

- **If special NF type elements are being used, this cut must take place in any case**, because otherwise, the gap width at the lateral element joint does not exactly correspond to the gap width in the element surface.

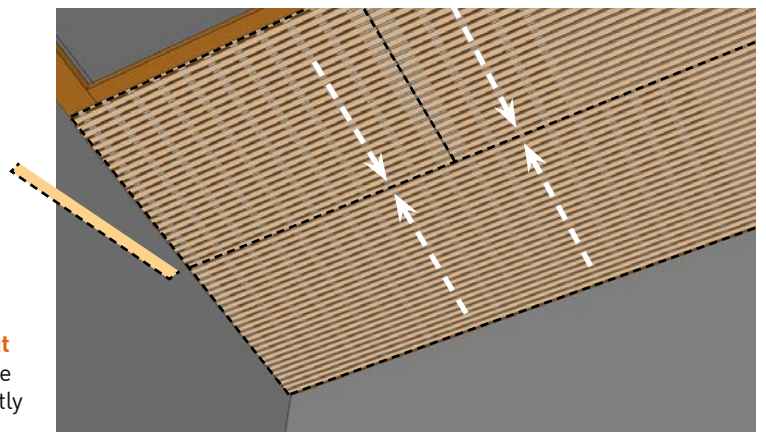

■ Type 3S-33 Installation

5. Element fastening alongside edges and around openings

- Also fasten elements in the middle of the element width alongside openings (use clamps or screws in the gaps), because minimal deformations of the elements might disturb the overall visual impression.

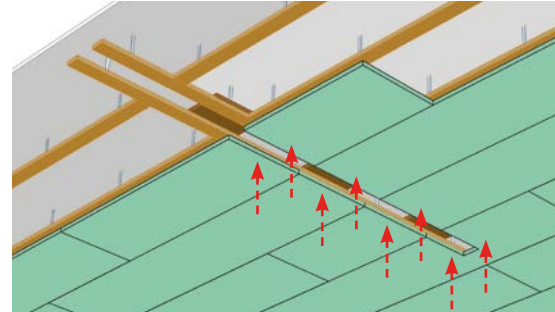

Installation in extraordinary locations

Special execution of substructure in case of demands for low flammability

■ Flame retardant substructure

Use impregnated battens (available on demand from Lignotrend).
Installation parallel to the elements' length, pitch 625 mm.

Deviant fastening in impregnated battens

with **fully-thread screw 3,5 x 40 stainless steel (V4A)**

a) special NF panels: apply screw diagonally.

b) standard panels: apply screw in the acoustic gap.

■ Noncombustible substructure

Use zinc coated steel sheet profile, e.g. CD 60/27 (DIN 18182),

Deviant installation at right angle to elements' length,

Pitch e.g. 700-800 mm / dependent on load.

Use special NF-panels, deviant fastening with sheet metal tapping screw (e.g. Würth, type pias® 3,5x25), apply diagonally, eventually pre-drill element before screwing and fix with a vice.

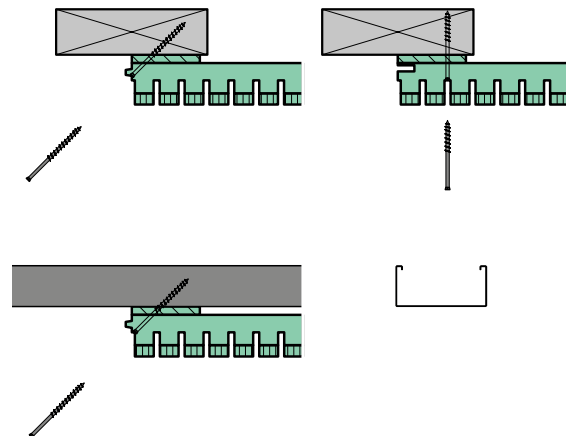

Application in indoor aquatic centres

- Lignotrend cross laminated timber panels are approved for the use in the service classes 1 and 2, where wood moisture content does not exceed 20%. **Application in indoor aquatic centres**, for example on the ceiling, typically is completely unproblematic.
- For safety reasons, a maximum moisture content could be defined at 15%, for example. The air's humidity dependent on temperature is limited to reach this goal by adjusting the ventilation system's humidity-control. Wood moisture content resulting as a function of the ambient atmosphere can be retrieved from the diagram below according to Keylwerth.



Fastening in the area of indoor aquatic centres

- Always use non-corroding screws and other connectors suitable for the aquatic centre climate (e.g. chlorine-containing air).
- Apply screws diagonally as shown on bottom of page 8.
- Screws suitable for chlorine in ambient air are made by Würth for example, type Assy 3.0 HCR, 4 x 50 mm, material no 1.4539 – corrosion resistance class IV, APV no: Z-30.3-6).
- The element should be pre-drilled if the screw that is being used does not have milling ribs on its head. First and last element row to be fixed through an acoustic ledge.

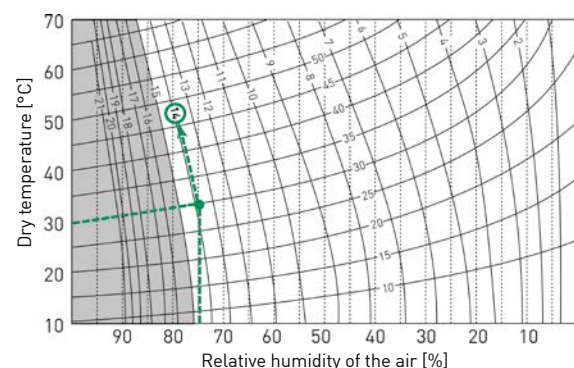

Type 3S-33 Termination

In order to achieve a visually appealing termination on free edges (e.g. openings, support penetrations), **one-ply-panel material of the same type of wood as the element view** is available from Lignotrend, on request also ready-to-use edge battens in identical surface treatment on request.

Commercially available metal profiles can alternatively be used as edge finish.

Proposal 1: Rebated terminal batten

Longitudinal edge

Face edge

In this example, the terminal batten is laterally butt-joined. It is fastened e.g. using nails or small clamps.

- Observe the different batten rebate geometry on longitudinal and face edge!
- One will need battens with half and full gap width as rebate width.

Standard terminal battens

Type	Batten height h	Rebate width	Batten width
63-2	63mm	2mm	14mm
63-3		3mm	15mm
63-4		4mm	16mm
92-2	92mm	2mm	14mm
92-3		3mm	15mm
92-4		4mm	16mm

[available from stock in silver fir, also B-s2,d0, Special dimensions and wood on demand!]

Proposal 2: Rebated terminal batten

Longitudinal edge

Face edge

A planed batten with a precisely defined distance from the element edge is mounted onto the elements' back as a reference edge for the terminal batten.

In this way, the identical joint and batten width like the elements' surface can be produced on the termination of the visible face.

Notes:

- Observe dimensional differences btw. lateral edge and face edge for the backside batten (Side: 5 mm, face 3 mm).
- We recommend arranging the last substructure batten on such edges (not shown) recessed to the last but one ledge of the rear element layer by approx. 20 cm.

[Representations exemplary for profile 625-12-4]

Proposal 3: Metal profile

Longitudinal and face edge

An L-profile is mounted as termination.

Notes:

- The joint visible will become smaller at the frame.
- Only feasible if fixing from above is possible (e.g. with pre-assembled sail).

■ Type 3S-33 Inspection flaps

Inspection flap, screwed on, for rare opening

Simple inspection flap, made from standard elements:

- Opening width = element width, opening length arbitrary
- Leave out desired opening when installing the panelling.
- Fit in the inspection flap, cut off the wooden stripe behind the groove on elements with groove and tongue, fix with a strap as a protection from falling down.
- Insert flap with plywood tongue on one side and close it using a special screw 3.5 x 40 in the acoustic gap on the other second side.

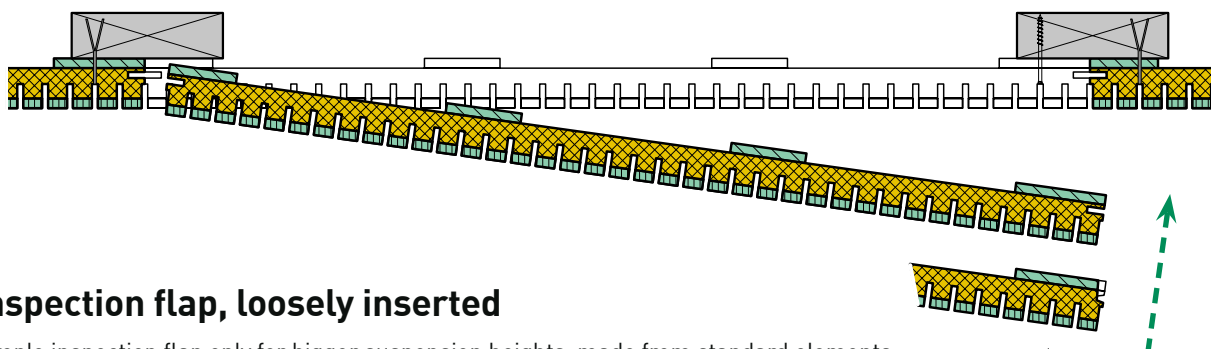

Inspection flap, loosely inserted

Simple inspection flap only for bigger suspension heights, made from standard elements:

- Opening width = element width minus width of substructure, opening length as requested, max. 1000 mm
- When installing the panelling, cut out desired opening to the desired opening size.
- Fit in the inspection flap, attach battens projecting some centimetres in length in both directions, onto the two middle rear-side ledges of the element, fix with a strap as a protection from falling down.
- Insert element, secure in the acoustic gaps through screw fitting of the load-bearing battens.

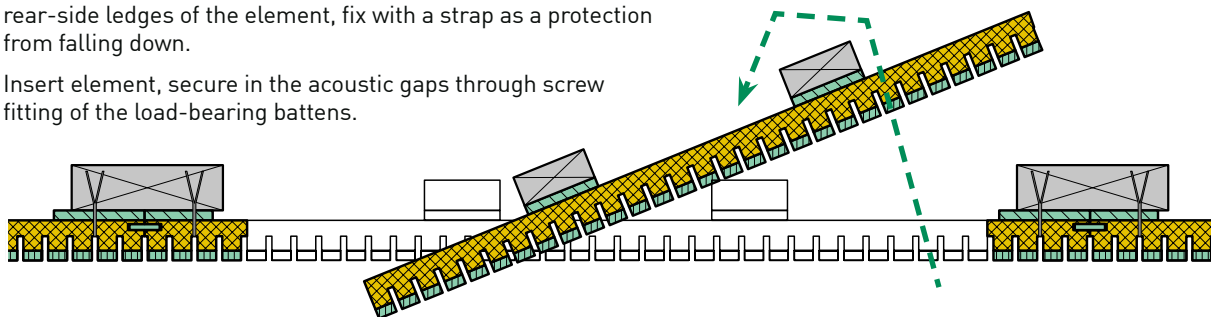

Factory-finished inspection flap with lock, for frequent opening

Pre-assembled inspection flap elements with hinge and lock in acoustic gap look, available from Lignotrend:

- Sturdy, visible metal rails on two sides
- Opening width = approx. 470 mm
Opening length (standard) = 625 mm, individual opening lengths on request
- Cut out desired opening when installing the panelling
- Fasten in the acoustic gap of the edging strip using special screws 3.5x40 (V4A)

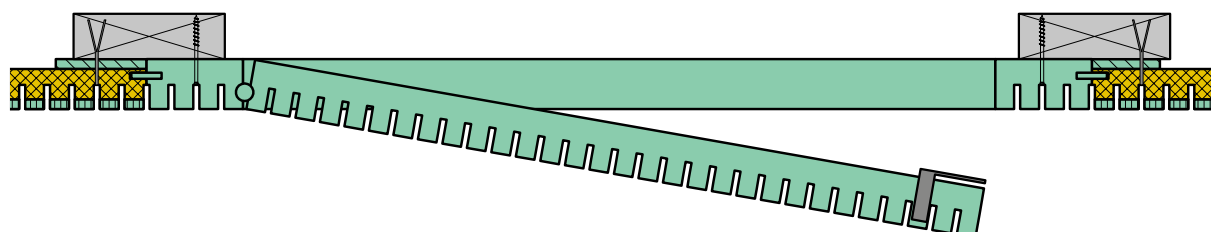

Type 3S-33 Special applications

Impact wall

We developed an impact wall construction for LIGNO Acoustic light that guarantees force reduction as required for sports halls (cf. **BAGUV requirements specifications for impact protection** – German Federal Association of Public-sector Accident Insurances e.V.). For this purpose, a multilayer substructure (brace and counterbrace configuration) is made from strips of Multiplex panels.

The effectiveness was tested at the MPA material testing laboratory in Stuttgart (test certificate no 902 1102 000-1/Sc/Whr): The demanded minimum force reduction of 60 % was greatly surpassed with values of up to 85 %.

In analogy, there is a test for surface not absorbing acoustically using a partly slit three-ply-panel ($d = 19 \text{ mm}$) as panelling (test certificate no 902 1102 000-2/Sc/Whr).



1st layer: **Horizontal battens** from Multiplex panel strips $50 \text{ mm} \times 18 \text{ mm}$ on support block $50 \text{ mm} \times 50 \text{ mm}$, thickness min. 18 mm or (for thicker wall constructions) vertical support batten, pre-drilled in each case

- Fastening depending on the base, with one screw per block, e.g. 6×90 in plastic dowel 8×40
- Battens' vertical grid: $e = 625 \text{ mm}$
- Support pad horizontal grid:
Type 3S-33: $f = 601 \text{ mm}$
Type 3S-62: $f = 625 \text{ mm}$
- Observe distance of the first block to the adjacent wall:
 $a = 110 \text{ mm}$

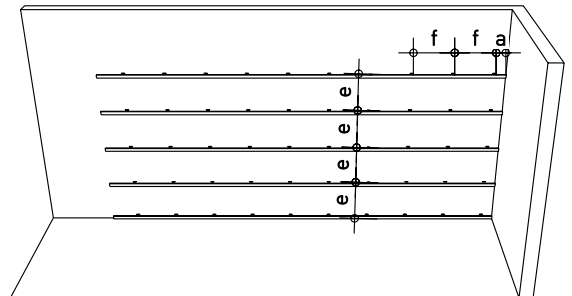

2nd layer: **Vertical battens** from Multiplex panel strips $50 \text{ mm} \times 18 \text{ mm}$, mount offset from support blocks by $f/2$

- Fastening with two screws 4×35 per crossing point
- Horizontal grid:
Type 3S-33: $f = 601 \text{ mm}$
Type 3S-62: $f = 625 \text{ mm}$

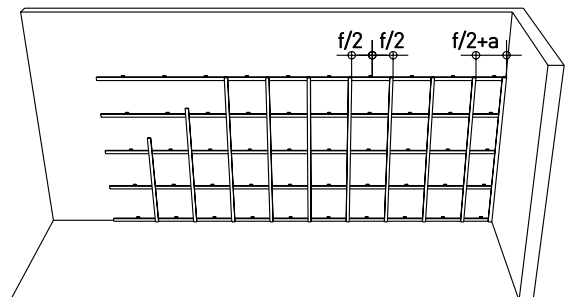

Impact wall panelling

- Prepare openings, cuttings and components to build in on the ground.
- Cut the element edge of the first element ❶ of the row such that the element begins with a wood transverse layer in full width (in this way, the transverse layers of the elements will always be directly above the vertical battens of the substructure).



- Mount panels without plywood tongue, fix them with screws here! Free frontal joints have to be lined. Observe all general installation instructions!

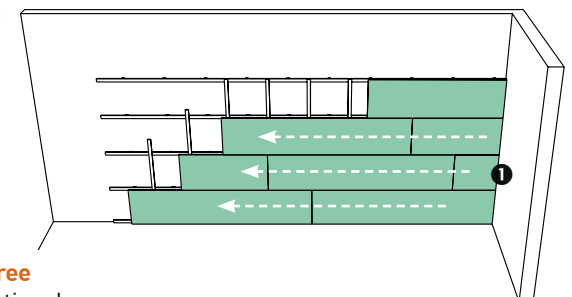

Horizontal section

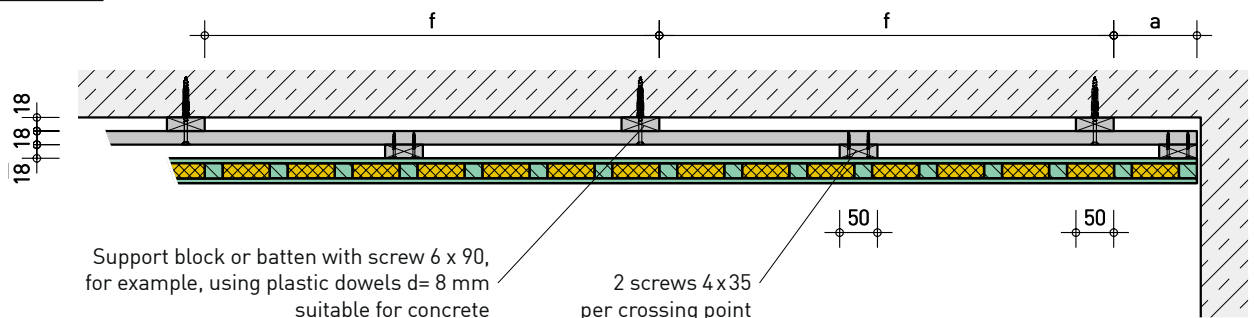

■ Type 3S-33 Special applications

Cuttings for grid ceilings

The LIGNO Acoustic light 3S-33 panels are available pre-cut for the purpose of inserting them into grid ceilings (e.g. from Donn profiles DX 24).

Width	613 mm
Length	613 mm
Weight	9,1 kg/m ² approx. 3,5 kg/panel
Other cuttings up to 625 mm in width on request	

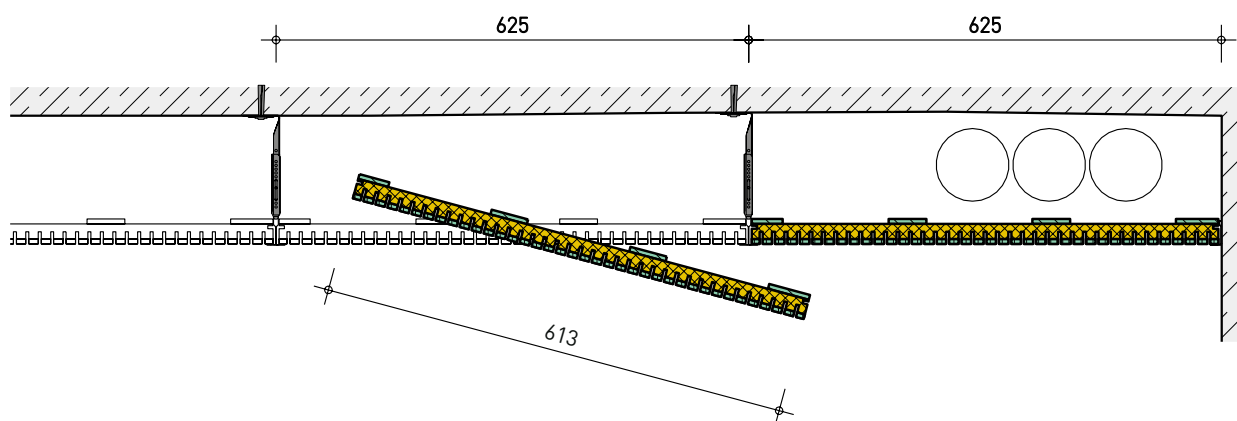

Freely suspended acoustic canopies

Assembled canopy for targeted, selective interruption of sound reflection. The load-bearing ceiling will not be thermally decoupled (e.g. when the building uses **activation of concrete core**).

The canopy consists of 2 LIGNO Acoustic light element strips, optionally one light fixture, aluminium edges and appropriate suspension cables and connection material.

Canopy width	1436 mm
Canopy length	1291 mm (in direction of the acoustic ledges)
Weight	approx. 22 kg (incl. light fixture)
Optional light fixture	1 pc. Trilux LUCEO H CDP 128/54 E03
Fastening	Cables (state required length when ordering), upper and lower brackets, hooks included
Other sizes on request.	

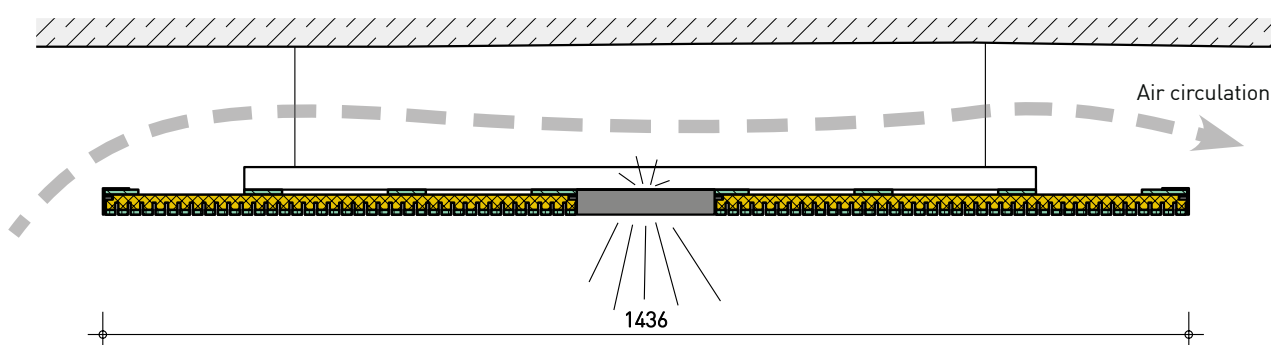

Type 3S-62 Geometry

Application

See pages 2-5

Availability

- Produced in individual length / continuously up to 8,000 mm
- In standard length 2,920 mm
- Available with normally inflammable surface

View:

Timber ledge profile

Wood types and profile alternatives ► from page 18

Absorber type A50G

Approx. 50% absorber portion in the transverse layer, absorber: Wood fibre

Lateral section:

Information on tolerance regarding elements' internal structure:

With constant total thickness of the element, the thickness of the visible and the rear layer can vary by approx. ± 0,5 mm. Also, the position of absorber strips and timber transversal layer can vary in the range of millimetres for production-related reasons.

Absorber variant R0 ('reflecting')

Gaps not slotted through as far as the absorber layer, absorber not effective as a result.

Lateral section:

Longitudinal section (individual lengths / continuously produced, type of absorber **A50G**):

2,400 to 8,000 (individual lengths)

general finger joint, approx. every 2,875 m

Longitudinal section (standard length 2,920 mm, type of absorber **A50G**):

2,920 (standard length)

standard lengths without general joint

■ Type 3S-62 Geometry

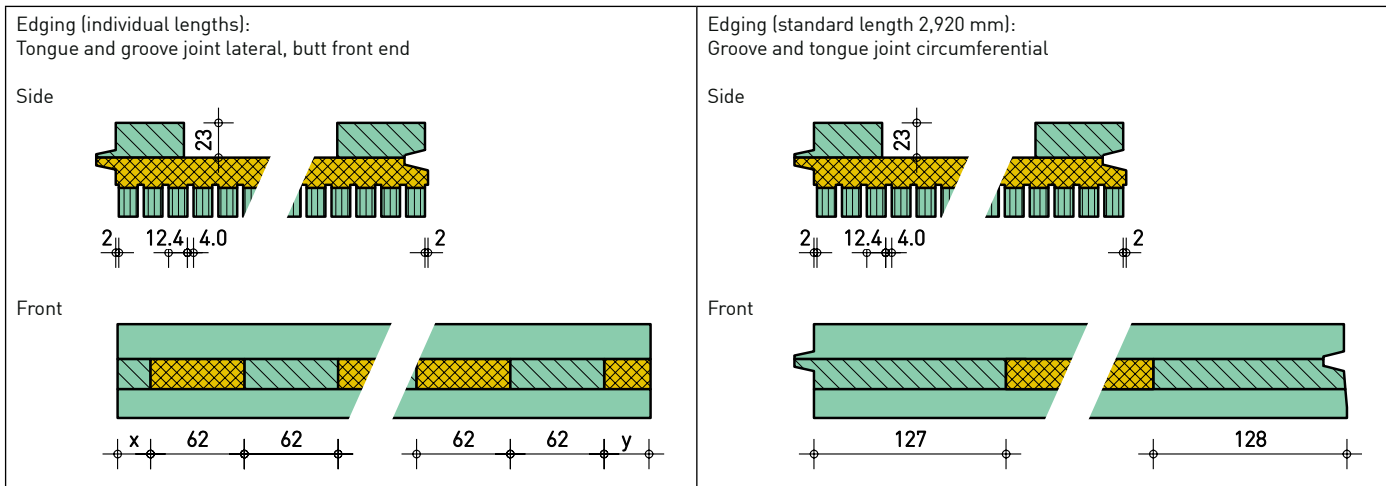

■ Type 3S-62 Installation

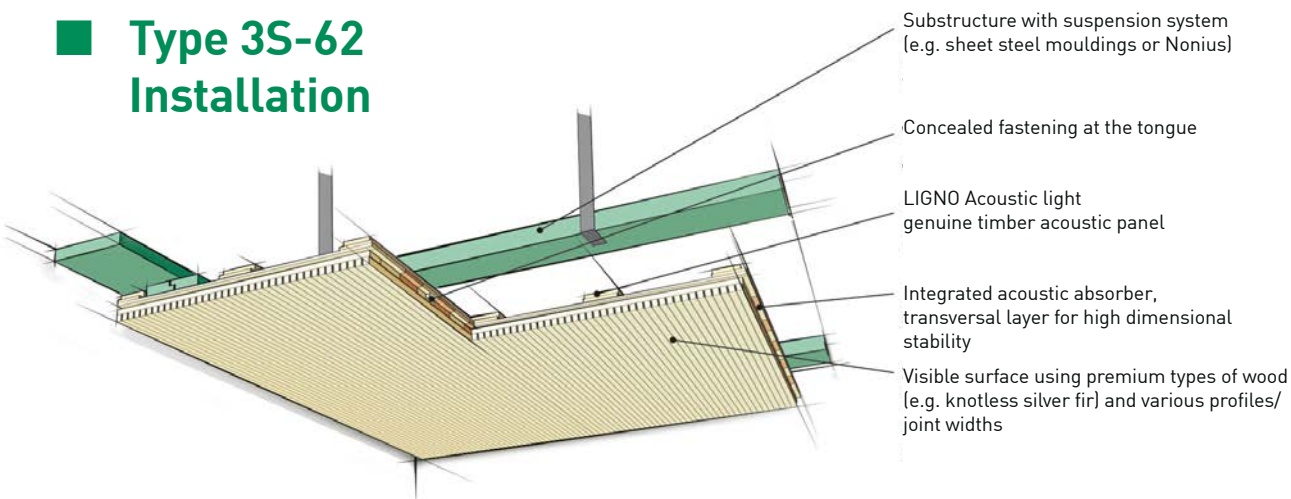

1. Substructure

- Elements LIGNO Acoustic light of type 3S-62 are – differing from type 3S-33 installed on a **substructure running at right angle to the element length**.
- Material for substructure: Timber batten (rectangular section): for example 40/80 mm, pitch 800-900mm, depending on load.
- Also place substructure around openings and alongside the edges of the wall/ceiling.
- Only use connectors approved for the building structure's material!
- Exactly level the substructure's lower edge horizontally.
- Installation directly to the building structure: Line if necessary (e.g. for reason of structure's unevenness).
- Alternative: Installation of substructure with suspension system suitable for wooden battens, e.g. two-piece "Nonius" type metal suspending brackets with bottom part designed for screw-on fixing on wood. Mind the manufacturer's specifications!

2. Fastening

- Concealed fastening in the zone of tongue joint using a diagonally set self-drilling partial-thread screw, min. 5 x 90, approx. 6 pcs./ panel in 2,92m length.
- First and last element row to be fixed through the acoustic gap or with rebated batten (see step 3).

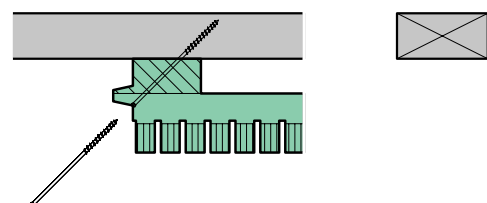

3. Element installation, first row

- Prepare all cuttings on the ground, also openings for components to build in.
- A shadow gap to the adjacent surface will elegantly compensate minor dimensional tolerances of the building.

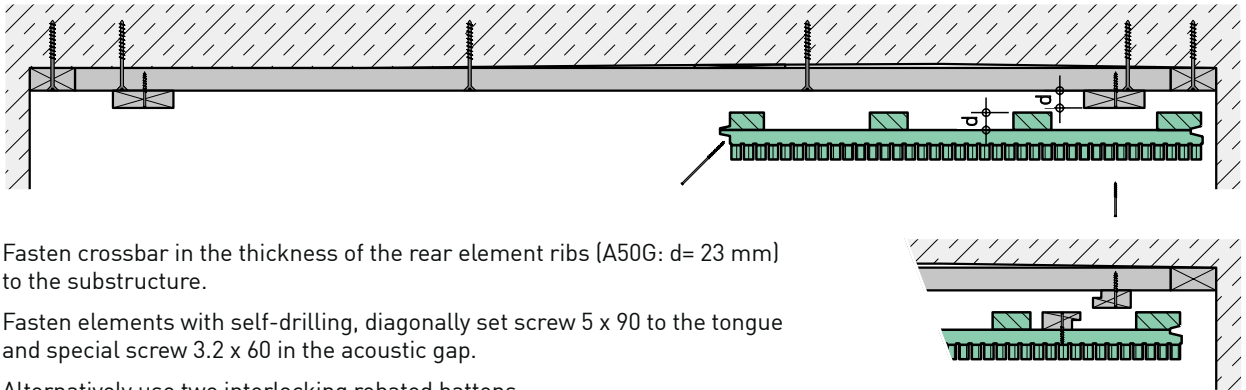

- Fasten crossbar in the thickness of the rear element ribs (A50G: d= 23 mm) to the substructure.
- Fasten elements with self-drilling, diagonally set screw 5 x 90 to the tongue and special screw 3.2 x 60 in the acoustic gap.
- Alternatively use two interlocking rebated battens.

- **All connection material must be applied in line with the elements' intermediate transversal layers' axis which is visible through the acoustic gaps, application of any fasteners through the wood fibre absorber is not allowed!**

4. Element installation, further rows

- Insert elements into groove/tongue joint and fasten at the tongue using a diagonally set screw 5 x 90.
- With elements in standard length, installation is carried out in the stretching bond (see page 9): The first element in the next row is the offcut of the last element of the previous row. No bond necessary with individual lengths (continuous).

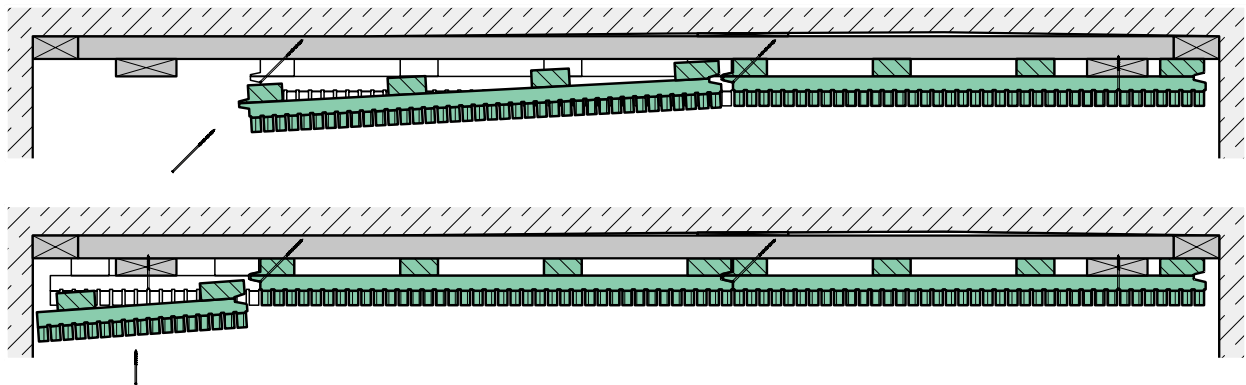

5. Alternative: Suspended installation

- Use of common suspension systems in combination with squared timber, better: Precisely straight U*psi F-120 profile from Lignotrend (when using Nonius type suspending brackets, choose use lower suspender part for screw-on installation on wood).

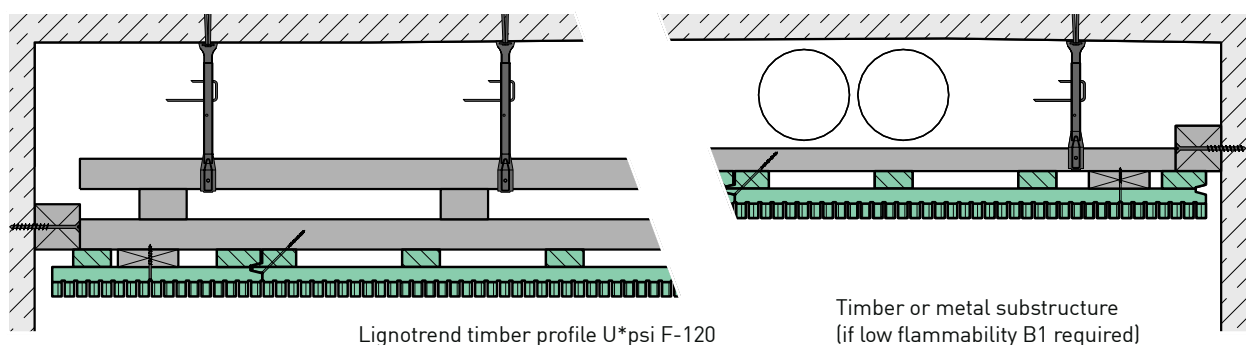









Surface

Available wood species

The surfaces are manufactured from one-ply-panels consisting of narrow lamellas. In the case of knotless sorting, the individual lamellas consist of pieces being largely free of knots, connected through finger joints in length. Most surfaces of the acoustic panels usually have received structural brushing.

For exact details and large pictures refer to the data sheet ► [TD LIGNO Surfaces](#) and to ► www.lignotrend.com/surfaces

			Type 3S-33					Type 3S-62						
			Profile											
			625-12-4	625-nat-4	624-21-4	625-19-6	625-25-8	625-12-4	625-nat-4	624-21-4	625-19-6	625-25-8		
Silver fir knotless, patterned	WTL		Predestined for unobtrusive architectural design is the light silver fir wood of Black Forest origin. It is processed in knotless quality: Knots are being cut out, the knotless pieces joined again obtaining high-quality visible surfaces.			■	■	■	■	■	■	■	■	■
Silver fir knotless, patterned, low flammability	WTL B-s2,d0		Impregnated version with flame retardant surface. Properties like WTL, but with slightly darker colour. Remark: For colour treatment, compatibility of paint and surface must be proven.			■ ¹	■ ¹	■ ¹	□	□	□	□	□	□
Silver fir knotless, plain	WTS		The plain sorting is something very special: A small amount of more evenly coloured wood with fine grains can be obtained from the tree trunks, from which this noble sorting is made.			■ ¹	■ ¹	■ ¹	■ ¹	■ ¹	■ ¹	■ ¹	■ ¹	■ ¹
Silver fir knotless, economy	WTE		Knotless version with flaws (e.g. somewhat larger longitudinal cracks, knots, fractures), for surfaces with lower quality requirements, for example in secondary rooms or on ceilings in great height. Irregularities are not perceived as a nuisance by many observers.			■	■	■	■	■	■	■	■	■
Spruce with fine knots	FI		The classic of wood surfaces is the spruce, processed as grown. Its uniform knot formations creates a homogeneous overall picture for the panel surface.			□	□	□	□	□	■ ²	■ ²	■	■
Larch knotless	LÄ		The wood of the larch has reddish shades. Like silver fir, it is processed knotless.			■ ¹	■ ¹	■ ¹	■ ¹	■ ¹	■ ¹	■ ¹	■ ¹	■ ¹
Oak knotless	EI		Rustique? As if! Oak is a trend! Just like the softwood surfaces, this robust, noble surface is made of wood processed knotless. This creates interiors with very high-quality appearance.			■ ¹	■ ¹	■ ¹	■ ¹	■ ¹	■ ¹	■ ¹	■ ¹	■ ¹
Beech knotless	BU		Beech gets a special character of its grain. With proper surface treatment, this appearance can be highlighted.			■ ¹	■ ¹	■ ¹	■ ¹	■ ¹	■ ¹	■ ¹	■ ¹	■ ¹
Stone pine with knots	ZI		The stone pine is native to the Alps. A beneficial physiological effect is attributed to the wood. It shall, for example, provide a healthy sleep.			□	□	□	□	□	■ ¹	■ ¹	■ ¹	■ ¹

¹ Extended delivery time possible!

■ possible

■ on demand □ not possible

² Not recommended, knots could fall out from narrow ledges

Surface: Flame retardancy

Element configuration

Flame retardancy

Only available for sorting Silver fir, patterned and not with all acoustic profiles!

By using an appropriately impregnated surface layer, acoustic panels LIGNO Acoustic light are produced with flame-retardant surface. Classification in accordance with DIN EN 13501-1.

Elements with flame-retardant surface may not be used in rooms with increased humidity.

LIGNO Acoustic light 3S-33 Silver fir, patterned	without further treatment	with UV-protection	with oiled finish	final treatment with B1-lacquer
625-12-4	■	■ ¹	■	■ ²
625-21-4	■ ²	■ ^{1,2}	■ ²	■ ^{1,2}
625-nature-4	■ ²	■ ^{1,2}	■ ²	■ ^{1,2}

■ B-s2,d0 according to classification report 902 1442 000-3 issued by MPA Stuttgart on Dec 16th 2011. Under European law, the classification report together with the CE marking and external monitoring of the production, the previous certificate is replaced.

■ B-s2,d0 derived from above mentioned classification report.

¹ Treatment does not show negative effect on the flammability in the laboratory test.

² Equivalence can be theoretically derived because gaps have the same width as the profile versions tested.

Element configuration

1. Form of base element

3S 3-layer element, four-batten backlayer, absorber open on back

2. Height

xx Height information in mm

Note: Individual lengths are only available with type 3S-62.

3. Design of absorber layer

e.g. **A70G**

The leading letter indicates the absorption property (A = absorbing/R= reflecting), the following number states the approximate percentage of absorber area proportion in the intermediate layer and the ending letter designates the absorber material.

Note: Not every element can be combined with every absorber layer, see table on page 21.

4. Type of wood surface

e.g. **WTL**

The LIGNO Acoustic light panels receive a surface made from real wood. The short name indicates the type of wood and sorting used.

Available surface finishes from page 18.

5. Acoustic profile

625-19-6 6 mm gap, 19 mm ledge

This information specifies the ledge dimensions of the acoustic profile: The leading number states the element width, the second one: the width of the ledge, the third number: the gap width.

See page 21 for available profiles.

Example: **LIGNO Acoustic light 3S-33 / A70G, WTL, 625-19-6**

■ Surface: Primer / finish / light reflectance

Ball impact resistance

According to the table below, panels can be provided ex works with a primer or final treatment applied on their surface.

Final treatment of acoustic panels is possible **for elements with a max. length of 5 m only**.

Please take into account that for elements with primer or colour applied, delivery time is longer.

Because of the variety of options, normally we only provide elements with final treatment after approval of an original sample.

		Without treatment		UV protective primer				Oiled finish				Painted finish			
		Brushed surface	Brushed surface	Brushed surface	Brushed surface ³	Transparent with UV-protection against darkening	W10-H / whitish, grain shining through	W20-H / white, grain scarcely shining through	Coloured	Transparent with UV-protection against darkening	W10-L / whitish, grain shining through	W20-L white	Coloured according to RAL/NCS	B1-paint transparent / coloured	Chalked-up and with transparent lacquer
Silver fir knotless patterned	WTL	■	■	■	■	■	■	■	■	■	■	■	□	□	
Silver fir knotl. patt-nd, flame-retardant	WTL B-s2,d0	■	□	■	■	■	■	■	□	□	□	□	■	□	
Silver fir knotless plain	WTS	■	■	■	■	□	□	□	■	■	□	□	□	□	
Silver fir knotless economy	WTE	■	■	■	■	■	■	■	■	■	■	■	□	□	
Spruce, fine knots	FI	■	■	■	■	□	□	□	□	□	□	■	□	□	
Larch knotless	LÄ	■	■	■	■	□	□	□	■	■	□	□	□	□	
Oak knotless	EI	■	□	■	□	□	□	□	■	□	□	□	□	■	
Beech knotless	BU	■	□	■	□	□	□	□	■	□	□	□	□	□	
Stone pine with knots	ZI	■	■	■	□	□	□	□	■	□	□	□	□	□	

¹ Surface can be treated on site with paints / glazes appropriate for the type of wood. ■ possible □ not possible

² Suitable for indoor use (not classified toxic). Based on water-soluble photoprotective agents, must be treated on site against water with a glaze, when washing-out cannot be excluded. Finish for example with transparent lacquer.
Caution: Treatment necessary after repair, for example by grinding.

³ For reasons of brushing, it may happen that some slats appear matt in sided light because of varying fibre orientation.

Properties concerning reflectance of light

Reflectance measurement according to DIN 5036 part 3	with transparent UV-protection			Same, but darkened (no UV-protection applied)	finished				
	Closed surface	Profile 625-12-4	Profile 625-25-8		Profile 625-12-4	Profile 625-21-4	Profile 625-nature-4	Profile 625-19-6	Profile 625-25-8
Silver fir knotless, patterned WTL									
Silver fir knotless, plain WTS									
Other types of wood	on request								



Ball-impact resistance

The ball-impact resistance for LIGNO Acoustic light panels in use on a wall or ceiling has been confirmed through laboratory testing using various installation variants. The test on the LIGNO Acoustic light elements was conducted with ledge profile (4 mm gap width / 12 mm ledge width) at the Stuttgart MPA material testing laboratory according to DIN 18032-3:1997-04. The test certificate can be requested from Lignotrend. Furthermore, there are tested substructures defined for **force-reducing impact walls**. ▶ [Page 13](#)

Absorber layer and acoustic profile

Acoustic absorber





In the elements' intermediate layer, timber and acoustic strips in different arrangements are placed in right angle to the visible ledge profile:

Type	Explanation	3S-33	3S-62	Certificate
A70G	Standard absorber (approx. 70% of the intermediate layer) Absorber material: Wood fibre, slightly water-repellent (make: Gutex Thermosafe, natureplus certificate no 0104-0710-012-4)	■	□	
A50G	Standard absorber (approx. 50% of the intermediate layer) Absorber material: Wood fibre, slightly water-repellent (make: Gutex Thermosafe, natureplus certificate no 0104-0710-012-4)	□	■	
R0	'Reflecting' layer: Either no absorber has been inserted here or the intermediate layer has no absorbing effect since the joints of the fair-faced layer do not reach into the absorber. Slightly increased element weight.	■	■	

■ possible □ not possible

Acoustic profile

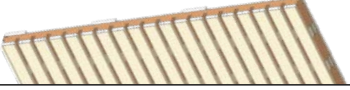
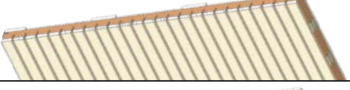
The surface layer will be furnished with a fine ledge profile. Behind the gaps, an absorber material acoustically effective is already integrated in the elements' production (standard: wood fibre).

Profile type	Gap width b_F	Ledge width b_L	No of ledges per element	Ball impact resistance	Flame retardancy
625-12-4 	4 mm	12,4 mm	38	■	■
625-19-6 	6 mm	19,0 mm	25	■	□
625-25-8 	8 mm	24,9 mm	19	■	□
625-21-4 	4 mm	21,0 mm	25	■	■
625-nature-4 	4 mm	approx. 12-25 mm		■	■
Other profiles on request					

■ possible ■ only with surface WTL B-s2,d0 □ not possible

Important note on selecting the acoustic profile

The profile with 625-12-4 should be avoided on large continuous wall surfaces in rather small rooms because this may result in optical irritations. Remedy: Pictures, darkly-treated partial areas, interruption through areas without relief pattern, choice of profile 625-21-4 or 625-nature-4. The ledge profile with 8 mm gap can be disadvantageous for the wall because the joints become transparent depending on light conditions and any staggered transverse layers would be seen.

Acoustic absorption Panelling with type 3S-33

ONLINE-CALCULATION

Predict the effect on acoustic quality for various room usages:

► www.lignotrend.com/acoustic-calculator

Absorber material is already integrated in the acoustic panels. During installation, extra absorber material only needs to be placed behind the panels when there are special requirements.

The visible surface with the acoustic gaps is **brushed strongly** to obtain additional positive **scattering of sound**.

Absorption coefficients

Full essays of the laboratory tests ► www.lignotrend.com
on demand also available printed.



Profile	α_w	SAK	NRC
12-4, 25-8	0,40	D	0,60
nature-4	0,40	D	0,60
21-4	0,40	D	0,55
19-6	0,45	D	0,65

Profile	α_w	SAK	NRC
12-4, 25-8	0,60	C	0,75
nature-4	0,65	C	0,75
21-4	0,65	C	0,75
19-6	0,65	C	0,70

Profile	α_w	SAK	NRC
12-4, 25-8	0,85	B	0,85
nature-4	0,80	B	0,80
21-4	0,75	C	0,80
19-6	0,80	B	0,80

Profile	α_w	SAK	NRC
12-4, 25-8	0,75	C	0,70
nature-4	0,70	C	0,70
21-4	0,70	C	0,70
19-6	0,75	C	0,70

Profile	α_w	SAK	NRC
12-4, 25-8	0,80	B	0,70
nature-4	0,75	C	0,75
21-4	0,75	C	0,75
19-6	0,80	B	0,75

see page 25 for the legend

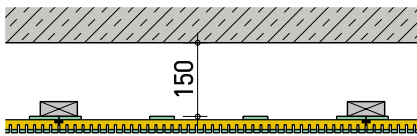
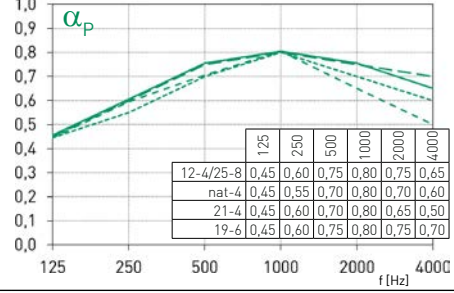
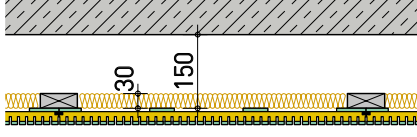
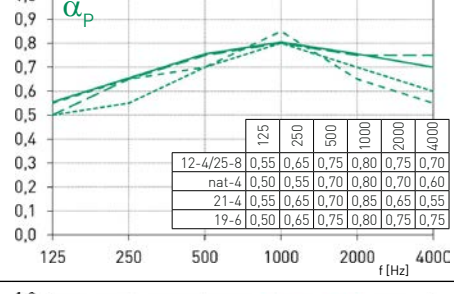
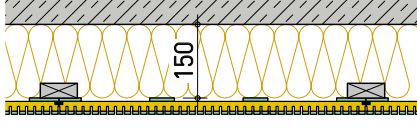
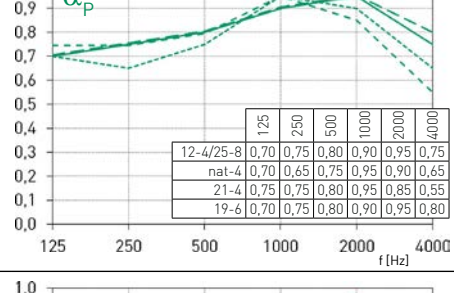
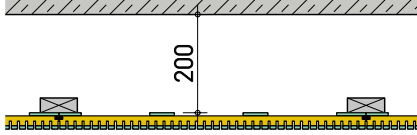
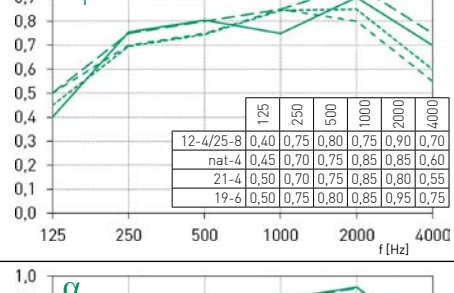
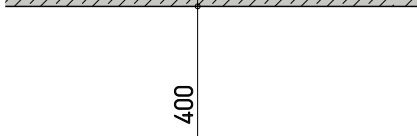
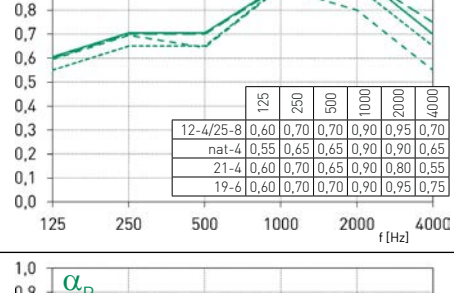
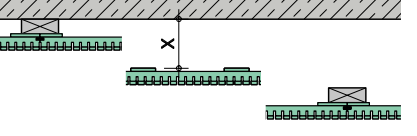
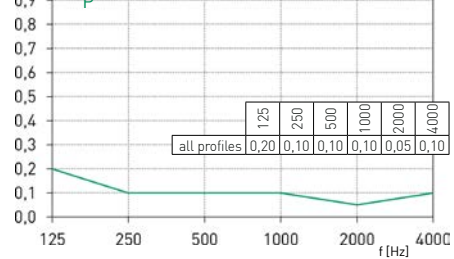
L06	LIGNO Acoustic light 3S-33 / A70G 150 mm cavity				 <p>Suspended installation.</p>	
	Profile	α_w	SAK	NRC		
	12-4, 25-8	0,75	C	0,70		
	nature-4	0,70	C	0,70		
	21-4	0,65	C	0,70		
19-6	0,80	B	0,70			
L07	LIGNO Acoustic light 3S-33 / A70G 150 mm cavity 30 mm extra absorber (hemp)				 <p>Suspended installation.</p> <p>Extra absorber: 30 mm hemp behind the panel (make: Thermohanf Premium) to improve absorption in the low frequency range.</p>	
	Profile	α_w	SAK	NRC		
	12-4, 25-8	0,80	B	0,75		
	nature-4	0,70	C	0,70		
	21-4	0,70	C	0,70		
19-6	0,80	B	0,75			
L08	LIGNO Acoustic light 3S-33 / A70G 150 mm cavity 150 mm extra absorber (rock wool)				 <p>Suspended installation</p> <p>Extra absorber: 150 mm rock wool behind the panel (make: Rockwool Sonorock) to improve absorption in the low frequency range.</p>	
	Profile	α_w	SAK	NRC		
	12-4, 25-8	0,85	B	0,85		
	nature-4	0,80	B	0,80		
	21-4	0,75	C	0,85		
19-6	0,90	A	0,85			
L09	LIGNO Acoustic light 3S-33 / A70G 200 mm cavity				 <p>Suspended installation.</p>	
	Profile	α_w	SAK	NRC		
	12-4, 25-8	0,80	B	0,80		
	nature-4	0,75	C	0,80		
	21-4	0,75	C	0,80		
19-6	0,85	B	0,85			
L10	LIGNO Acoustic light 3S-33 / A70G 400 mm cavity				 <p>Suspended installation.</p>	
	Profile	α_w	SAK	NRC		
	12-4, 25-8	0,80	B	0,80		
	nature-4	0,75	C	0,80		
	21-4	0,70	C	0,75		
19-6	0,85	B	0,80			
L11	LIGNO Acoustic light 3S-33 / R0 Sound "reflective"				 <p>Element without noteworthy absorption for partial areas that shall "reflect" sound.</p> <p>The height x of the cavity is not relevant for absorption.</p>	
	Profile	α_w	SAK	NRC		
All profile types	0,10	-	-	-		

Acoustic absorption Panelling with type 3S-62

ONLINE-CALCULATION

Predict the effect on acoustic quality for various room usages:

► www.lignotrend.com/acoustic-calculator

Absorber material is already integrated in the acoustic panels. During installation, extra absorber material only needs to be placed behind the panels when there are special requirements.

The visible surface with the acoustic gaps is **brushed strongly** to obtain additional positive **scattering of sound**.

Absorption coefficients

Full essays of the laboratory tests ► www.lignotrend.com
on demand also available printed.



Profile	α_w	SAK	NRC
12-4, 25-8	0,60	C	0,60
nature-4	0,60	C	0,60
21-4	0,65	C	0,60
19-6	0,55	C	0,60

Profile	α_w	SAK	NRC
12-4, 25-8	0,65	C	0,65
nature-4	0,60	C	0,60
21-4	0,65	C	0,60
19-6	0,55	C	0,60

Profile	α_w	SAK	NRC
12-4, 25-8	0,60	C	0,60
nature-4	0,60	C	0,55
21-4	0,60	C	0,55
19-6	0,60	C	0,60

Profile	α_w	SAK	NRC
12-4, 25-8	0,65	B	0,65
nature-4	0,65	C	0,60
21-4	0,65	C	0,60
19-6	0,65	B	0,60

Profile	125	250	500	1000	2000	4000
12-4/25-8	0,20	0,40	0,55	0,70	0,75	0,70
nat-4	0,25	0,40	0,50	0,65	0,75	0,75
21-4	0,20	0,40	0,60	0,60	0,75	0,65
19-6	0,20	0,40	0,55	0,75	0,75	0,60

Profile	125	250	500	1000	2000	4000
12-4/25-8	0,25	0,45	0,55	0,70	0,75	0,70
nat-4	0,25	0,45	0,50	0,70	0,75	0,70
21-4	0,25	0,45	0,55	0,70	0,65	0,55
19-6	0,30	0,45	0,45	0,65	0,75	0,75

Profile	125	250	500	1000	2000	4000
12-4/25-8	0,10	0,30	0,60	0,70	0,70	0,70
nat-4	0,15	0,30	0,60	0,70	0,65	0,60
21-4	0,10	0,30	0,65	0,70	0,60	0,55
19-6	0,20	0,35	0,55	0,70	0,70	0,70

Profile	125	250	500	1000	2000	4000
12-4/25-8	0,30	0,40	0,65	0,70	0,70	0,65
nat-4	0,30	0,40	0,60	0,70	0,65	0,55
21-4	0,30	0,40	0,65	0,70	0,60	0,50
19-6	0,30	0,40	0,60	0,70	0,70	0,65

Profile	125	250	500	1000	2000	4000
12-4/25-8	0,35	0,45	0,60	0,70	0,75	0,65
nat-4	0,35	0,45	0,55	0,70	0,70	0,55
21-4	0,40	0,45	0,60	0,70	0,65	0,50
19-6	0,40	0,45	0,55	0,70	0,75	0,70

L17 LIGNO Acoustic light 3S-62 / A50G
150 mm cavity

Profile	α_w	SAK	NRC
12-4, 25-8	0,70	C	0,65
nature-4	0,65	C	0,60
21-4	0,60	C	0,60
19-6	0,70	B	0,60

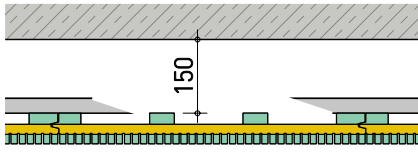

Suspended installation.

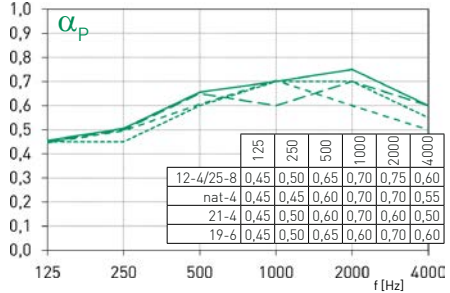

L18 LIGNO Acoustic light 3S-62 / A50G
200 mm cavity

Profile	α_w	SAK	NRC
12-4, 25-8	0,55	D	0,60
nature-4	0,55	D	0,55
21-4	0,55	D	0,55
19-6	0,55	D	0,60

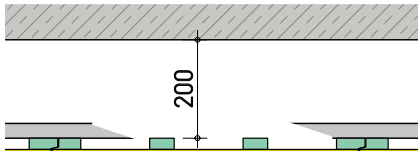

Suspended installation.

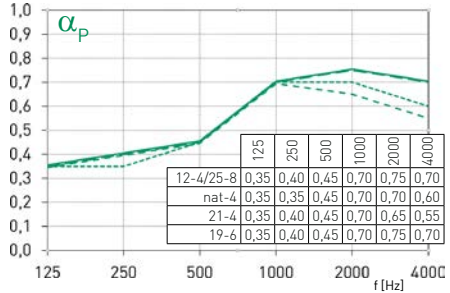

L19 LIGNO Acoustic light 3S-62 / A50G
400 mm cavity

Profile	α_w	SAK	NRC
12-4, 25-8	0,50	D	0,60
nature-4	0,50	D	0,55
21-4	0,50	D	0,50
19-6	0,50	D	0,55

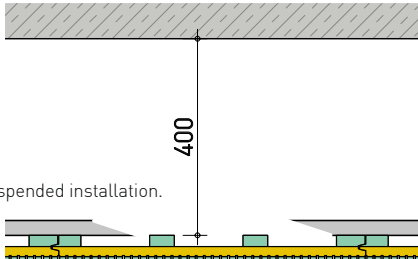

Suspended installation.

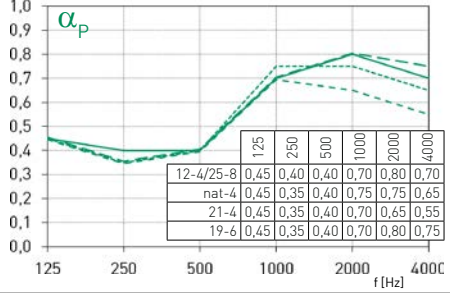

L20 LIGNO Acoustic light 3S-33 / R0
Schall"reflektierend"

Profile	α_w	SAK	NRC
All profil types	0,10	-	-

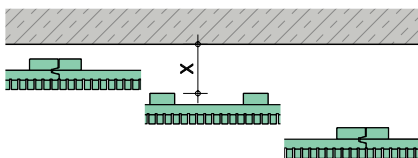

Element without noteworthy absorption for partial areas that shall "reflect" sound.
The height x of the cavity is not relevant for absorption.

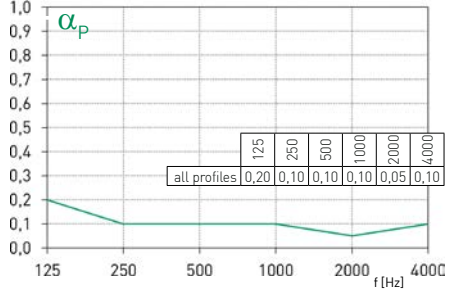

α_w Weighted noise absorption coefficient according to DIN EN ISO 11654
SAK Noise absorber class
NRC Noise reduction coefficient

Online calculation tool for room acoustics

There is an online calculation tool available on our website to examine the acoustic properties of various room types ► www.lignotrend.com/acoustic-calculator.

Note:

The analysis software only determines the necessary absorber area for the cubage described and does not provide information about the arrangement of the absorber areas in the room. The results should therefore be regarded as orienting and they do not substitute the evaluation of the building project through a person (e.g. acoustics expert engineer) competent in room acoustics.

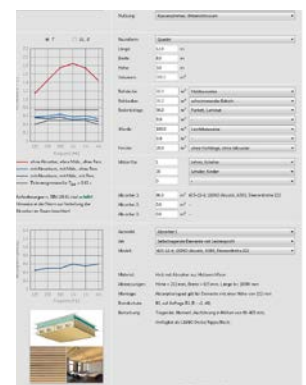

Acoustic absorption of canopies

Element weight

ONLINE-CALCULATION

Predict the effect on acoustic quality for various room usages:

► www.lignotrend.com/acoustic-calculator

Absorber material is already integrated in the acoustic panels. During installation, extra absorber material only needs to be placed behind the panels when there are special requirements.

The visible surface with the acoustic gaps is **brushed strongly** to obtain additional positive **scattering of sound**.

Absorption coefficients

Full essays of the laboratory tests ► www.lignotrend.com
on demand also available printed.

— x = 200 mm
- - - x = 400 mm
... x = 800 mm

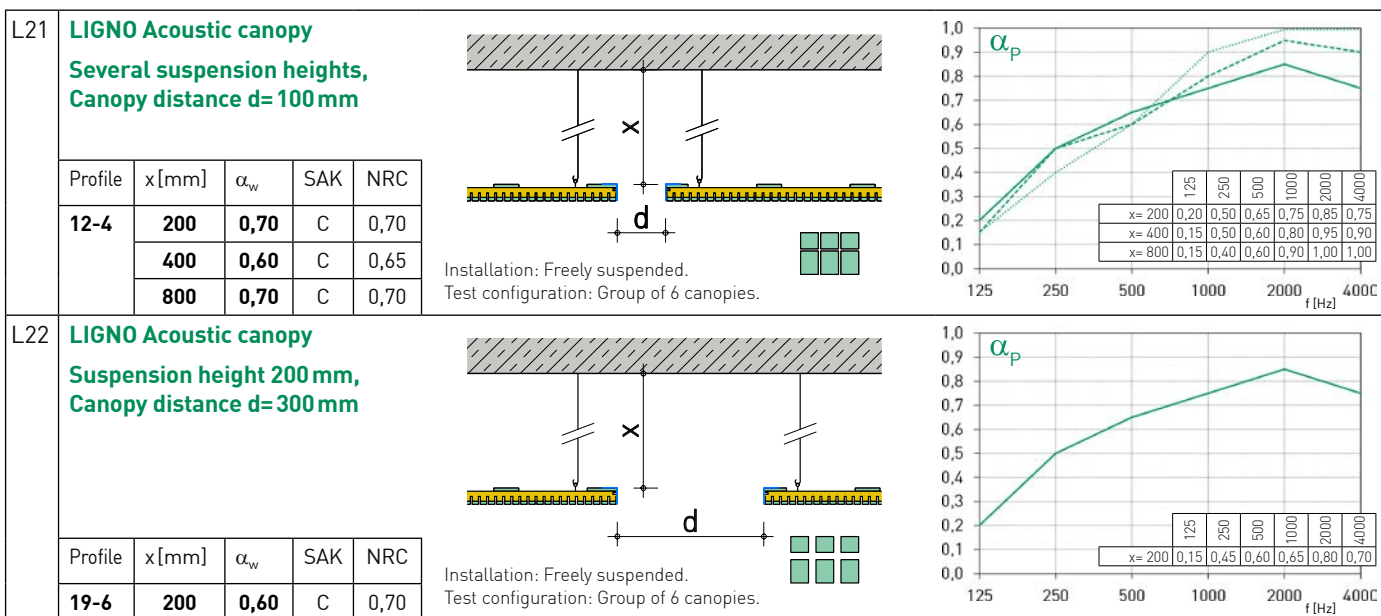

Element weights

Type		3S-33	3S-62	
Width covered		625	625	mm
Length covered	Standard	2920	2920	mm
	Individual / continuous	-	2,400 to 8,000	mm
Weight	Softwood surface, all profiles except 625-21-4	9,2 (16,8)	18,2 (33,1)	kg/m ² (kg/element)
Excess weight	Oak surface	+1,0 (+1,8)	+2,9 (+5,2)	kg/m ² (kg/element)
	Profile 625-21-4	+0,5 (+0,9)	+0,8 (+1,5)	kg/m ² (kg/element)
	Absorber R0 instead of A70G/A50G	+2,7 (+4,9)	+1,0 (+1,8)	kg/m ² (kg/element)
	Absorber A50H instead of A50G	-	+4,5 (+8,3)	kg/m ² (kg/element)
	Surface B-s2,d0/B1	+0,4 (+0,8)	+1,4 (+2,6)	kg/m ² (kg/element)

(Values in brackets indicate the weight per element in standard length 2.92 m)

Green building

The independent organisation natureplus has certified the basic versions of the LIGNO Akustik light products (spruce/fir wood-types) based on expert analyses of the TÜV (German Technical Inspection Agency). In addition, there are also natureplus certificates for the standard absorber types A70G and A50G. Among others, the products were tested for:

- Compliance with stringent emission limit values
- Origin of the wood (FSC/PEFC sources), sustainable production of the elements
- Function



Checklist Invitation to tender

Checkliste

Material for panelling	
LIGNO Acoustic light acoustic panels	Allow for a reserve in quantity for offcuts.
Insulating mats	If required, for backing (e.g. hemp, supplier: Lignotrend)
UV protection	If required, for curing spots that were ground on the building site, supplier: Lignotrend.
Material for simple batten substructure	
Battens	Solid wood, e.g. cross-section 30 / 100, e= 625 mm (type 3S-33) or 40 / 60, e= 800 mm (type 3S-62)
Dowels and fasteners	Select according to base
Clamps	For fastening the elements in the acoustic joints (type 3S-33 only), see page 8 for specification
Screws	As required (type 3S-33), replacing clamps, special fully-thread drilling screws 3,5 x 40 (V4A) (supplier: Lignotrend) or partial-thread drilling screws 5 x 90 (type 3S-62), see pages 8/10)
Battens for lining	For fastening the first elements and end elements or in case a lateral section should follow between the rear webs, see cross-section drawings for thickness
Screws with narrow head	Special fully-thread drilling screws 3,5 x 40 (V4A) for fastening first/end elements in the acoustic gap (supplier: Lignotrend).
Rebated strip	Alternative for first elements and end elements (type 3S-62 only)
Nails	For securing the end elements from rebated strips falling down (type 3S-62 only)
Material for higher suspension, e.g. with U*psi	
U*psi F-120-Profil	As precisely straight, light timber substructure (source: Lignotrend)
Abhängesystem	Commercially available systems, e.g. Nonius suspension or Würth ceiling quick-fixing anchor W-DS.
Material for termination	
Edge battens with rebate	As per detail selected, available from Lignotrend on request
Battens, planed	For fastening onto the element rear side as a stop for the edge batten
Tools	
Immersion saw with rail (circular saw)	For cutting the elements to size.
Jigsaw	For internal corners, round cut-outs.
Hammer drill / rotary hammer	For installation on concrete / masonry.
Cordless screwdriver	
Special bit with extended tip	If screw fitting takes place in the gaps (supplier: Lignotrend)
Staple gun with special foot	(3S-33 only). See page 8, loan device available from Lignotrend.
Drill bit tube / Forstner drill, incl. battens in 4, 6 or 8 mm width	For downlights or similar, battens are inserted into the joint for large holes in order to prevent the battens from breaking away.
One-handed ceiling prop(s)	To temporarily hold the elements while fastening.
Chalk line / spirit level / line laser	Chalk line for marking the positions of the first elements on the substructure in true alignment.
Sanding paper / brush	For touching up fouling and re-application of sanded off UV protection glaze.
Gloves / dust mask	We recommend wearing gloves during installation to avoid contamination.

Tender templates

Detailed texts for invitation to tender on all Lignotrend elements with templates for planning and statics, delivery and installation, trimming and subassembly are available in digital form (in GAEB, RTF or PDF format) from the Internet under www.lignotrend.com as well as on the Lignotrend CD-ROM.

Processing guidelines

The explanations given below must be adhered to without fail.
Please convey the helpful hints also to your customers, developer or follow-up trades!

Incoming goods

Receiving controls		
Package undamaged?		Please check it immediately upon receipt and contact Lignotrend in case of any discrepancies. Phone +49 (0) 7755-9200-0.
Delivery scope (panels, accessories) correct?		
Wood moisture content $9 \pm 2 \%$?		
Date / name / signature		



Unloading and displacing the packages with a forklift or lifting cart, do not suspend with straps!
Use a crane fork when unloading with a crane.

General information

Lignotrend products, particularly the acoustic panels come with a top-quality visible surface. Hence, it is essential to pay particular attention to having **clean hands** or rather wear **gloves** and do not step on visible surfaces.

Minor longitudinal curvatures of the elements are possible due to minimal differences in wood moisture in the layers and do not represent any deficiency. These curvatures can be compensated by warping against the substructure during installation.

Timber is a natural product and its natural properties, deviations and characteristics therefore always have to be taken into account. In particular, when buying and using it, the purchaser must take into consideration its biologic, physical and chemical properties. The spectrum of natural differences in colour, structure and other qualities within one type of wood is a part of the properties of wood as natural product and does not warrant any complaint or liability claim.



Storage

Carefully **protect** the elements using suitable covering material against: **Moisture** of any kind (rain, fog, splash water, snow), wind as well as **sun** (UV radiation). Store pallets levelled and on clean squared timber. Because of the risk of the formation of condensate beneath the packaging foil: **Storage in dry, closed buildings only!**



Processing

Acclimatisation: Prior to processing, the elements shall be stored in the climate conditions that will prevail in the room later. Bei Failure to comply may, for example, cause gaps to form on the frontal element butt. It is recommended to install elements **not before plastering and floor screed are dried**. Deviant, in case of installation of elements with flame-retardant surface, drying process of plastering and floor screed **must** have terminated!

Please orient yourself by the details described in this documentation during installation. Your Lignotrend technical advisor will be at your disposal for checking an individual, detailed solution in cases where you should have deviating basic conditions in your project.

Appropriate measures to **protect wood surfaces** from marks, stains or damage must always be taken. An important point is the soft padding of the installation props at their top, for example, through a clean piece of carpet. Wearing thin gloves is recommended.

Industrial safety has top priority. Therefore, meet the standard safety precautions with regard to working!

Disposal

Waste released during processing of Lignotrend elements can be disposed of like other waste wood, packaging material (foils/wood) must be disposed of by the processing party according to the local law governing waste.



Cleaning and maintenance

Simple vacuum-cleaning of the visible surface using a brush attachment is absolutely sufficient. If that should prove insufficient, wiping with a damp cloth is possible but **without any detergents!** One should brush and not sand if there is a high dirt accumulation. Take care in case of surfaces that have been treated with a UV protection: Colour differences must be anticipated in this case – contact us.

Expert advice

Do you have any questions about planning, invitation to tender or processing? Do you require a sample piece? Do you need an individual quote? Contact the nearby technical advisor: www.lignotrend.com/consultants