

PROJECT PLANNING GUIDE - ELECTRICITY & CONTROL

Swegon WISE



Demand-controlled ventilation
has never been easier

Swegonⁱ

Contents

Complete overall solution at all levels	3
System.....	3
Sub-systems	3
Zone.....	3
Room	3
Documentation structure	3
Operating network and radio network.....	4
Radio network	4
Operating network	4
Connection of the operating network.....	5
Physical connections	6
TCP Ports	6
IP settings for Swegon network.....	6
SuperWISE II/SuperWISE II SC.....	7
Connection of SuperWISE to the main control system	7
WISE DIR.....	8
GOLD	8
Connection in the radio network	9
Climate products	10
WISE Parasol	10
WISE Colibri Ceiling.....	11
WISE Sphere Ceiling	12
WISE Sphere Free.....	13
WISE Damper	14
WISE Measure	15
System products	16
WISE RTA.....	17
WISE IAQ.....	18
WISE IRT	19
WISE OCS	20
WISE IORE	21
WISE IRE.....	23
WISE WCS	24
WISE RTS.....	25
Electrical project planning examples	26
Offices with airborne climate	26
Office with waterborne climate CAV	27
Office with waterborne climate DCV	28
Conference room with water and airborne climate	29
Office with airborne climate in balance	30
Classroom with airborne climate in balance	31
Classroom with airborne climate with fume hood ventilation in balance	32
Open-plan office with water and airborne climate with balanced extract air	33
Hotel room	34

Complete overall solution at all levels

For many years now, Swegon's system for demand-controlled ventilation has set the standard for combining optimum indoor climate with minimum energy use. Over time knowledge regarding demand control and user friendliness has been expanded. This was vital as development within the industry is moving towards significantly increased demands - be it

environmental, net operating income or comfort. Based on experience, we have developed the WISE system from scratch, where all products interact with each other to meet both current and future demands. WISE is based on unique technologies, which combine to form a reliable and flexible system.



Documentation structure

To support installation of a WISE system, Swegon has created a documentation structure.

System guide

The system guide provides the designer with help and advice on the structure of systems and rooms.



System guide

Project planning guides

Our project planning guides provide assistance to the respective disciplines involved with issues that can arise when designing their part of a system.



Heating, Cooling & Ventilation

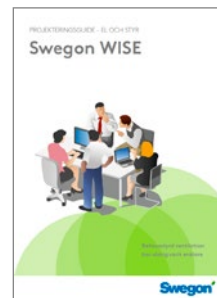

Electricity & control

Operating network and radio network

The WISE system is built up of an operating network and a radio network. The operating network is the fixed IP-network while the radio network is based on a patented robust wireless communication system. This project planning guide describes how the operating network and radio network are structured and how the different components in the WISE system are connected. For detailed information about the whole system, see the WISE System guide.

Operating network

Radio network

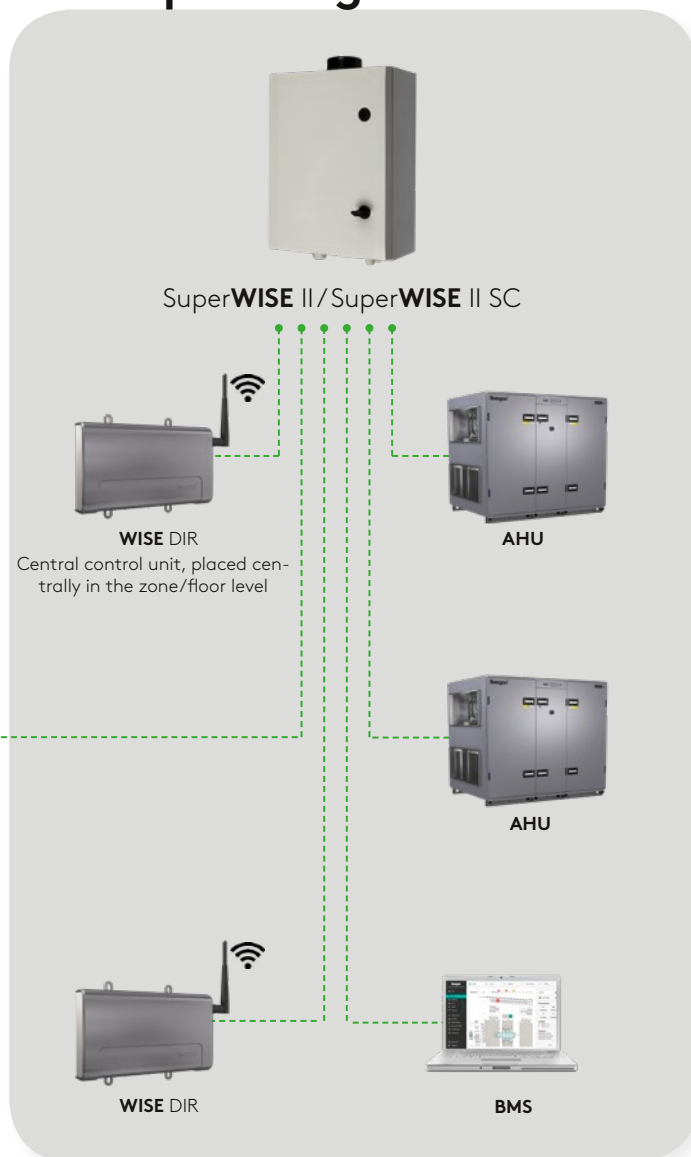
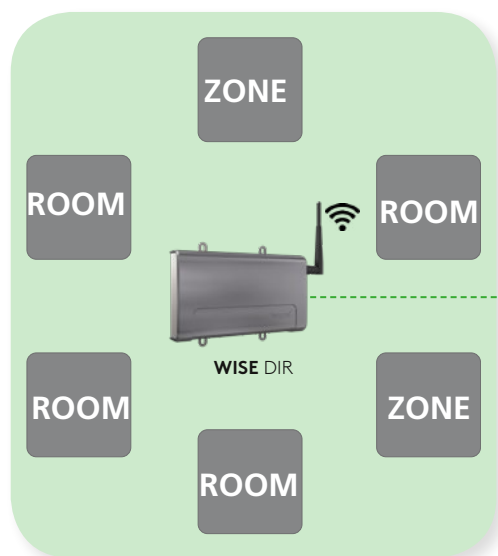

----- 8-way communication cable with RJ45 connectors.
Max cable length 100 metres communication cable.

NOTE! The radio and operating networks shown in this document are only examples of how these can be structured. The radio and operating networks are built up depending on the need and function in the building project.

Connection of the operating network

The base products in WISE are interconnected through a hardwired IP network. It is this IP network that is called the “operating network”. To make a comparison with mobile telephone system you can compare the base products with the fixed infrastructure that permits the wireless system.

Base products are:

- SuperWISE II / SuperWISE II SC
- WISE DIR
- AHU, for example, GOLD
- Swegon CONNECT (only SuperWISE II SC)

NOTE!

- **Swegon recommends that the operating network is segmented solely for Swegon products, this is to ensure operation of the indoor climate system.**
- **Commissioning of the WISE system cannot take place until the operating network is operational.**

Depending on the conditions in the project, Swegon supports two solutions for how the operating network can be structured:

1. Swegon network - no operating network

- For example, an old property without an existing infrastructure for IP-network or BMS.
- Swegon provides documentation for project planning, cable routing, IP addressing, etc.
- For smaller installation, all Swegon products are connected directly to the switch in the SuperWISE cabinet.
- For larger installations additional switches can be added.

2. Property owner provides the operating network

- Usually large projects.
- The operating network is managed in its entirety by the property owner.
- Swegon products are assigned connections and IP-addresses to the operating network by the property owner.

1. Swegon network

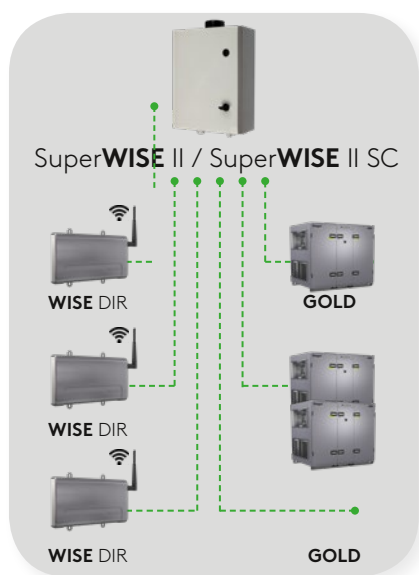

2. Property owner provides the operating network

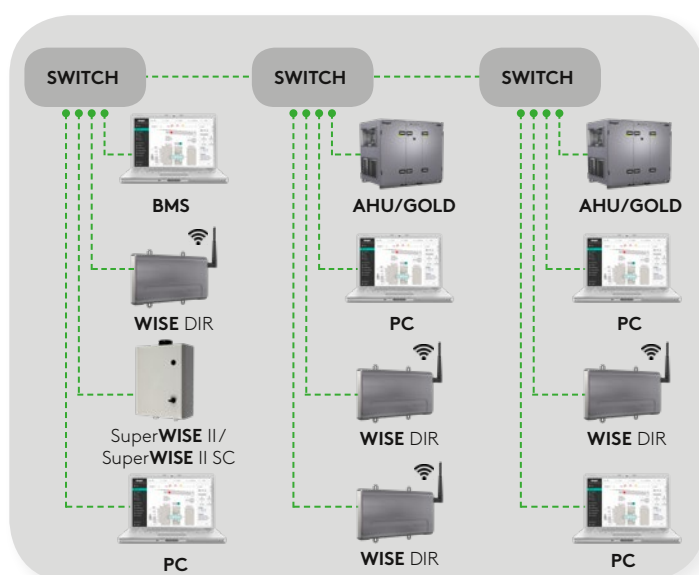

----- 8-way communication cable with RJ45 connectors
Max cable length 100 metres communication cable.

NOTE! The radio and operating networks shown in this document are only examples of how these can be structured. The radio and operating networks are built up depending on the need and function in the building project.

Physical connections

Markings of the physical connections to the operating network are specified below for Swegon's products.

Product	Markings of the physical connections
SuperWISE II	Operation/Switch
WISE DIR	4
GOLD IQlogic	B
Swegon Connect	ETH 0/Switch

IP settings for Swegon network

These settings must be used for the Swegon network when there is no other operating network.

Addressing	Static IP
Network	192.168.100.0
Net mask	255.255.255.0
Default route and Swegon Connect Router	192.168.100.1
SuperWISE	192.168.100.2
WISE Director	192.168.100.3-49
GOLD	192.168.100.50-99

TCP Ports

Internal services

The following services are used internally in the operating network. In order for the products to work as designed, the specified TCP ports must be open between products internally in the operating network.

Service	Port number
Swegon Gold	TCP 10080
Swegon	UDP 12347
http	TCP 80
https	TCP 443
SSH	TCP 22
MQTT	TCP 1883
Rsync	TCP 873
DHCP	UDP 67:68

External services

The following services are provided externally by the products on the operating network. In order for the services to work externally outside of the operating network, the defined TCP ports must be open to the specified products.

Service	Port number
DNS	UDP 53
DNS	TCP 53
NTP	UDP 123
http	TCP 80
https	TCP 443
Modbus	TCP 502
Bacnet	UDP 47808
SMTP in	TCP 25 (Modifiable in SuperWISE)
SMTP out	TCP 25 (Modifiable in SuperWISE)

SuperWISE II / SuperWISE II SC

SuperWISE / SuperWISE SC are the common points in the system where all information is linked together to be presented on web pages and external communications protocol, e.g. Modbus.

Electrical data

Power supply: 230V 10 A

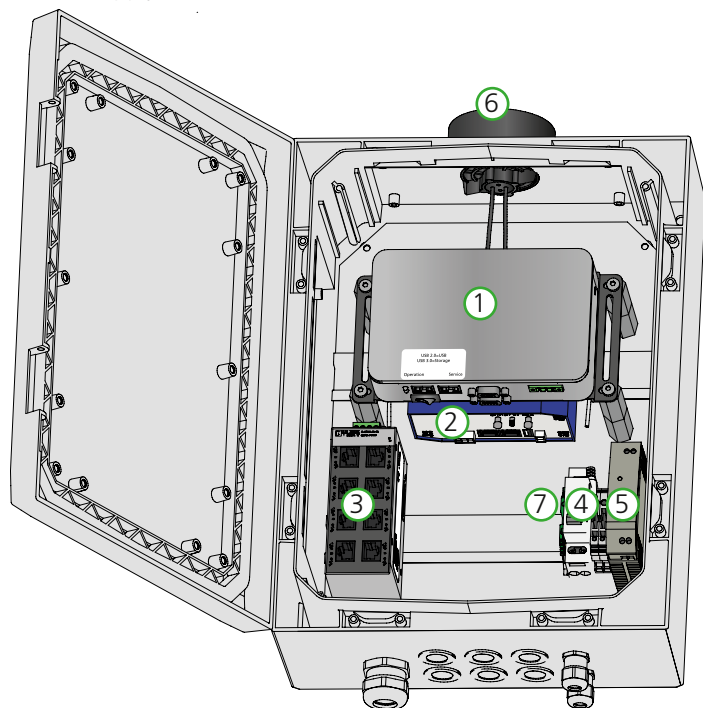

SuperWISE II, SuperWISE II SC.
NOTE! Swegon Connect (2) and antenna (6) only included in SuperWISE II SC.

1. SuperWISE control unit - Main communication unit
2. Swegon Connect - Router (is only included in SuperWISE II SC). Communicates on the mobile network and ideally on the 4G network. If the cabinet contains Swegon Connect, the cabinet must be placed so that it can receive mobile signals. The cabinet can be supplemented with an extra antenna for increased signal strength (see Accessories) for improved mobile coverage. See the separate documentation for Swegon Connect on www.swegon.com
3. Switch - 8 ports (if more ports are required, install a supplementary switch outside of the cabinet)
 - Port 1: SuperWISE control unit
 - Port 2: Swegon Connect
 - Port 3-8: Free for e.g. WISE DIR/AHU/BMS
4. Main switch - Connection of the power supply
5. Transformer
6. Antenna, only included in SuperWISE II SC
7. Earth connection

Connection of SuperWISE to the main control system

SuperWISE manages operating information to and from the BMS via ModBus TCP or BACnet IP.

SuperWISE has the BACnet profiles BACnet Building Controller (B-BC) and BACnet Gateway (B-GW) implemented and uses BACnet protocol revision 14. Descriptions of all specific possibilities via BACnet in SuperWISE can be found in the PICS document.

The main control system is connected via the Ethernet port to Switch (3), where ports 3-8 are intended for e.g. BMS, or directly to the SuperWISE controller.

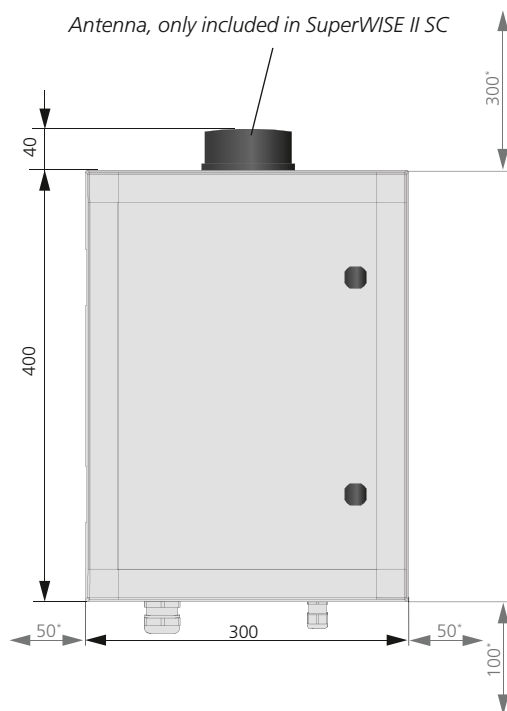

SuperWISE II, SuperWISE II SC, measurement figure.
*Minimum free clearance to nearby installations.

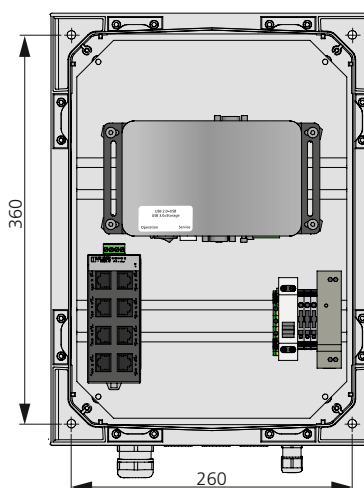

Holes for installation, SuperWISE II, SuperWISE II SC.
4x installation screws (clearance hole $\varnothing = 8$ mm), screw selection based on the substrate.

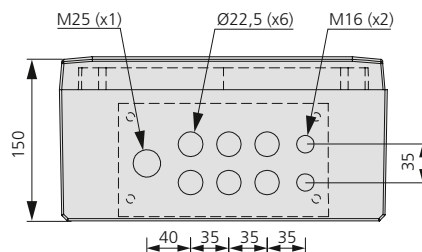

SuperWISE II, SuperWISE II SC, underside.

Weight (kg)	
SuperWISE II	5.8
SuperWISE II SC	6.3

WISE DIR

The majority of calculations for the system are made here. WISE DIR is a central control unit in WISE which wirelessly collects data, processes and sends data back to a group of climate and ventilation products to control and regulate the indoor climate. Each system needs at least one WISE DIR to work. WISE DIR communicates with SuperWISE via an Ethernet cable.

Electrical data

Power supply: 24 V AC $\pm 10\%$ 50-60 Hz,
24V DC (15-30V)

Max. power consumption: 5 VA

Cable rating, connector: Power: max. 2.5mm²

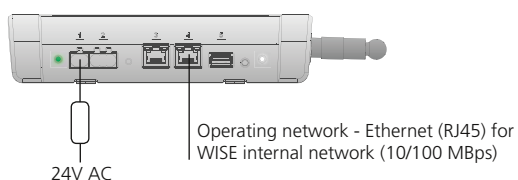
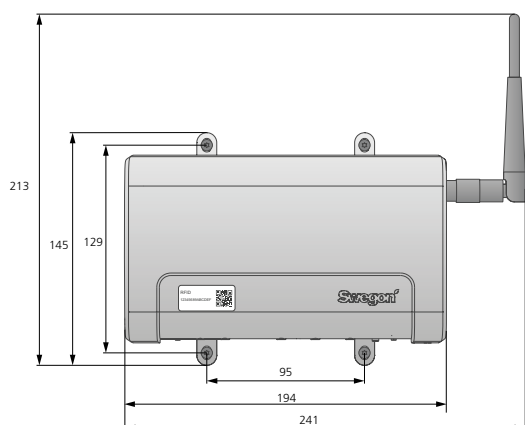

WISE DIR, connection.
NOTE! Antenna must always be installed vertically.

GOLD

For more information about the connection of the GOLD air handling unit, see www.swegon.com.

Connection in the radio network

The room products in WISE communicate wirelessly in the radio network by sending signals to WISE DIR. For the best radio communications place WISE DIR, which is physically connected to the operating network, as central as possible in the radio network.

The system's room products communicate wirelessly with the built-in radio transmitter. Products with a power supply work both as a transmitter and receiver and boost/repeat the system's radio communications. Products powered by a battery act only as transmitters and receivers of information.

NOTE! During commissioning, the products are paired with the help of TuneWISE.

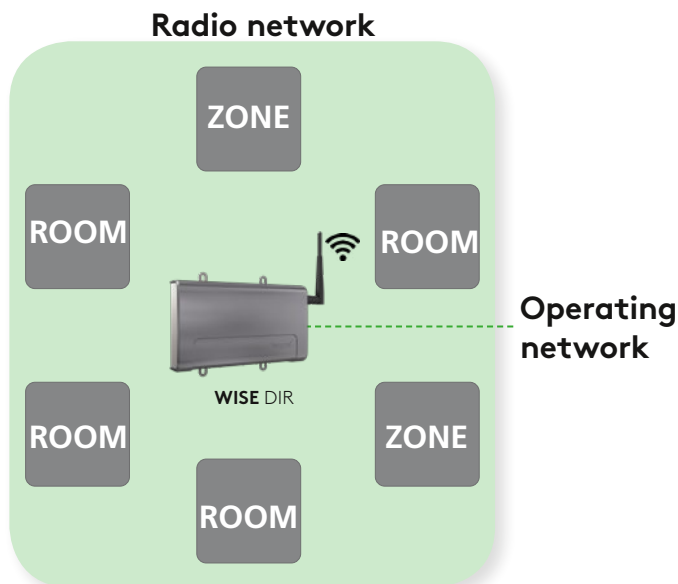

Radio network example

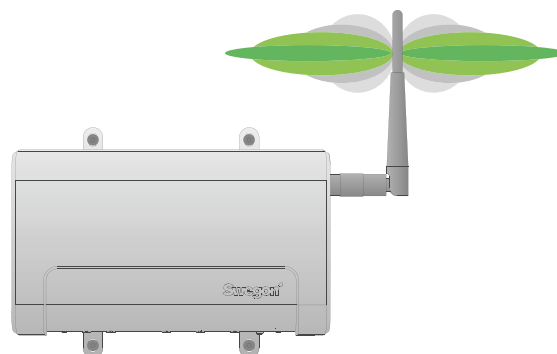

WISE DIR, distribution of radio signals (distributed 360° around the antenna).

The WISE system comprises room products for both air and waterborne climate systems, all the requisite control equipment, as well as room units and sensors. All this is linked together to form an entirety via a unique patented system for wireless communications. The wireless system is based on a meshed structure where each unit forwards information about nearby products, which helps the network to work around obstacles. This also means that the system can quickly repair itself if a product, for example, loses power.

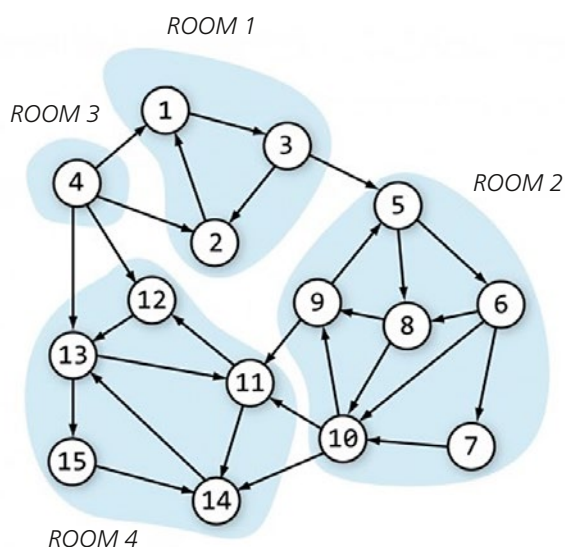

Meshed structure

Climate products

WISE Parasol

Comfort module with integrated radio module that demand controls air flow and cools/heats via built-in water coils Measures air flow.

Electrical data

Power supply: 24V AC $\pm 15\%$ 50 - 60Hz
 Connections pipe dim.
 Power: Screw terminal max. 2.5mm²
 Valve actuator: Push-in spring force connections, max. 1.5 mm²
 Total power consumption: Max 30 VA.
 Max. power consumption: See table below

		VA / unit	Standard VA total
Default	CU	2.3	5.1
	DPS Modbus	0.8	
	Damper motor (315C)	2	
Optional Extras	Actuator, ACTUATORb	7	
	SMA	0.8	
	SMB	0.6	

Example:
 WISE Parasol in standard version with the following options:
 Actuator for cooling and heating as well as WISE SMA, gives a total power consumption of $5.1 + 7 + 7 + 0.8 = 19.9$ VA

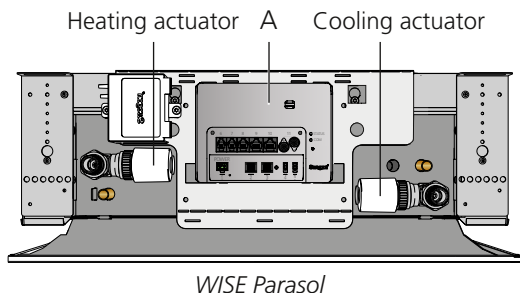

WISE Parasol with factory-fitted components

A. WISE CU - Controller Unit

- Connection of the power supply
- Connection of the valve actuator for heating and cooling (accessory)

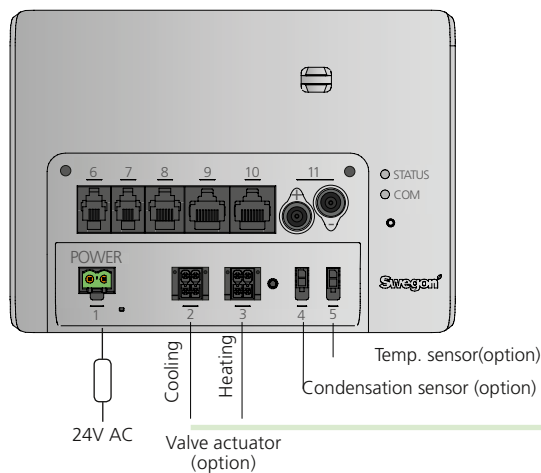

Connection example WISE Parasol (terminal 2 cooling, terminal 3 heating)

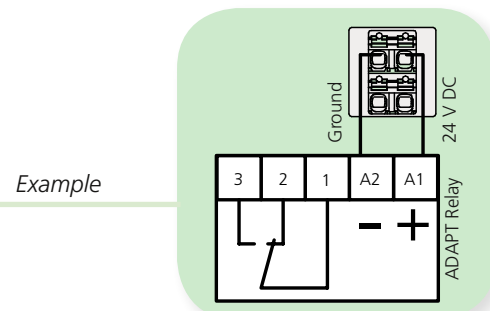
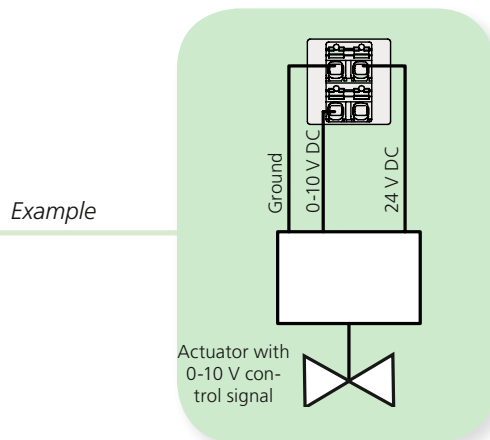
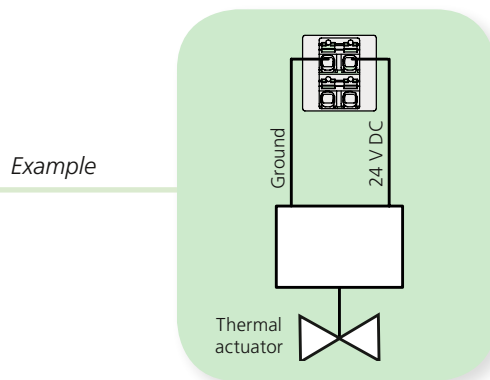

WISE Colibri Ceiling

Air diffuser with integrated radio module that demand controls air flow and controls an external heat source. Measure air flow, supply air temperature, room temperature and presence.

Electrical data

Power supply:	24V AC ±15% 50 - 60Hz
Connections pipe dim.	
Power:	Push-in spring force connections, max. 2.5 mm ²
Valve actuator:	Push-in spring force connections, max. 1.5 mm ²
Max. power consumption:	See table below

Variant	VA			
	Default	+1 valve actuator	+2 valve actuator	+3 valve actuator
Ø160, Ø250	8	15	22	29*

*Applies to products with CU ver. 2, delivered from 10/01/2019

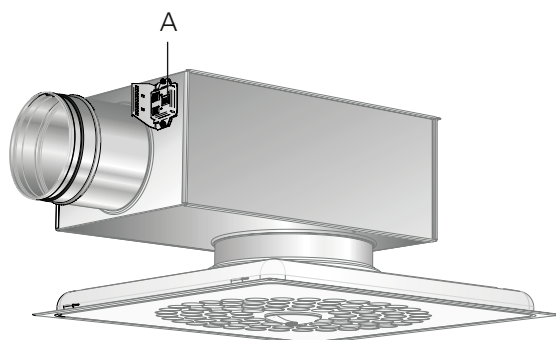

WISE Colibri C

WISE Colibri C

A. Diffuser connection

- Connection of the power supply (2 and 3)
- Connection of the valve actuator for heating (1) (accessory)

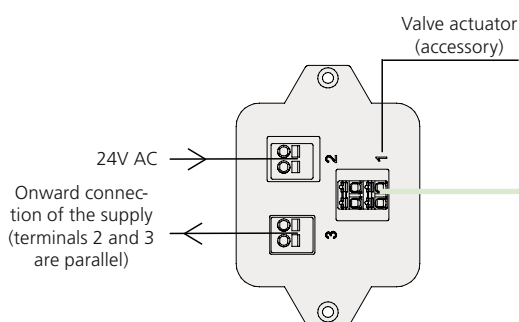

WISE Colibri C, diffuser connection

Connection example WISE Colibri C

Example

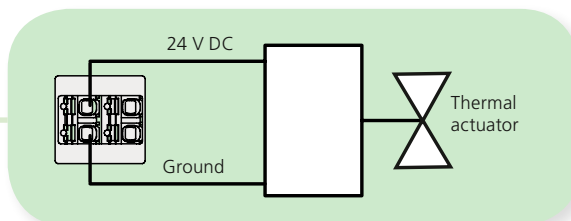

Connection of thermal actuator

Example

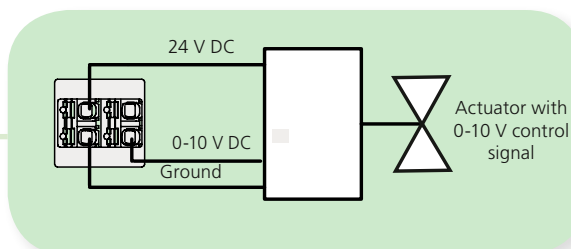

Connection of actuator with 0-10 V control signal.
NOTE! 24 V DC supply

Example

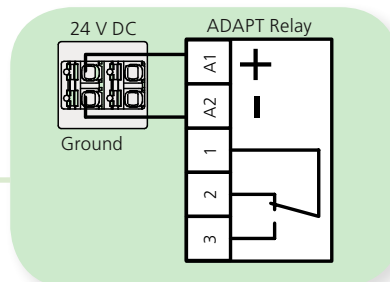

Connection of relay for connection of additional actuators

WISE Sphere Ceiling

Air diffuser with integrated radio module that demand controls air flow and controls an external heat source. Measures air flow, supply air temperature, room temperature and presence.

Electrical data

Power supply: 24V AC ±15% 50 - 60Hz

Connections pipe dim.

Power: Push-in spring force connections, max. 2.5 mm²

Valve actuator: Push-in spring force connections, max. 1.5 mm²

Max. power consumption: See table below

Variant	VA			
	Default	+1 valve actuator	+2 valve actuator	+3 valve actuator
Ø160, Ø200	8	15	22	29*

*Applies to products with CU ver. 2, delivered from 10/01/2019

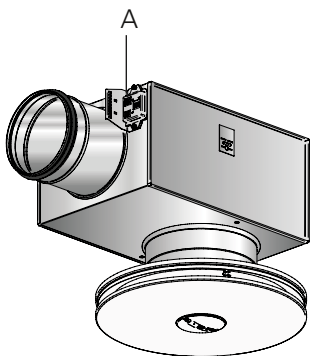

WISE Sphere C

WISE Sphere Ceiling

A. Diffuser connection

- Connection of the power supply (2 and 3)
- Connection of the valve actuator for heating (1) (accessory)

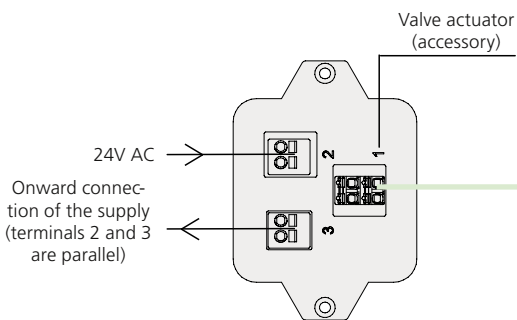

WISE Sphere C, diffuser connection

Connection example WISE Sphere C

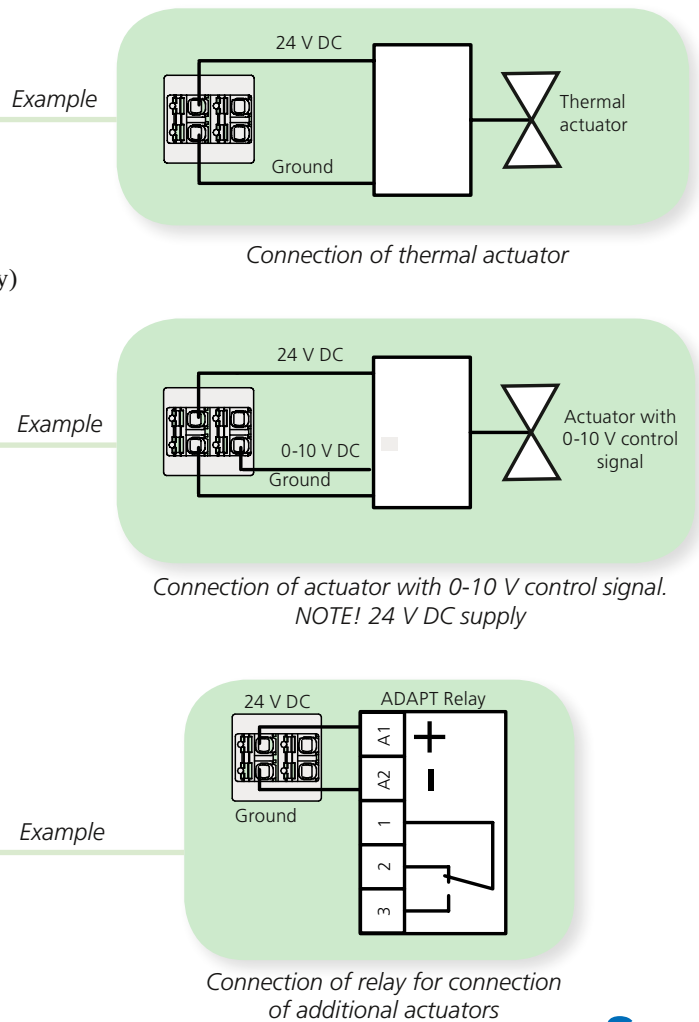

WISE Sphere Free



Air diffuser with integrated radio module that demand controls air flow and controls an external heat source. Measures air flow, supply air temperature, room temperature and presence.

Electrical data

Power supply: 24V AC ±15% 50 - 60Hz

Connections pipe dim.

Power: Push-in spring force connections, max. 2.5 mm²

Valve actuator: Push-in spring force connections, max. 1.5 mm²

Max. power consumption: See table below

Variant	VA			
	Default	+1 valve actuator	+2 valve actuator	+3 valve actuator
Ø160, Ø200	8	15	22	29*

*Applies to products with CU ver. 2, delivered from 10/01/2019

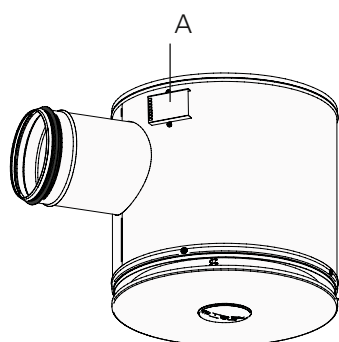

WISE Sphere F

WISE Sphere Free

A. Diffuser connection

- Connection of the power supply (2 and 3)
- Connection of the valve actuator for heating (1) (accessory)

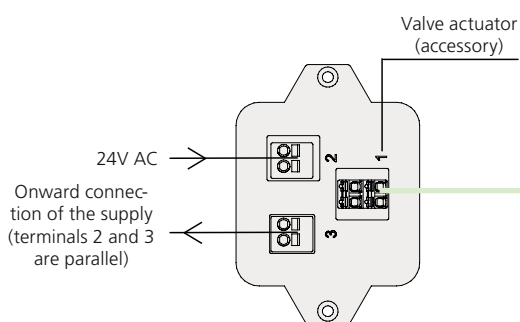

WISE Sphere F, diffuser connection

Connection example WISE Sphere F

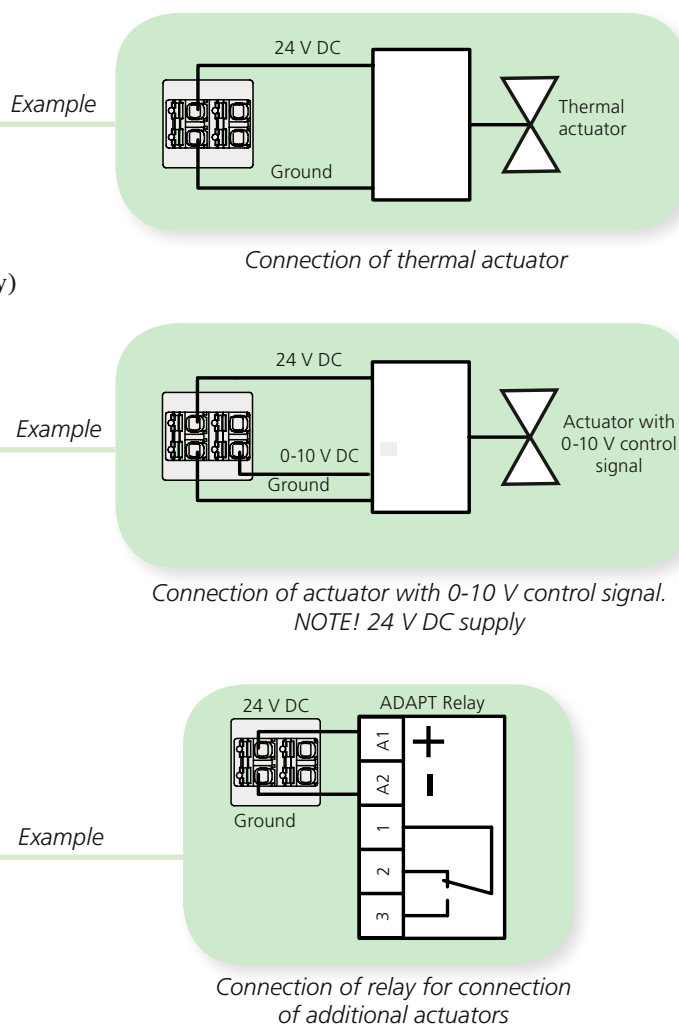

WISE Damper

Damper with integrated radio module that demand controls air flow and controls an external cooling/heat source. Measures air flow and duct temperature.

Electrical data

- Power supply: 24V AC ±15% 50 - 60Hz
- Connections pipe dim.
- Power: Screw terminal max. 2.5mm²
- Valve actuator: Push-in spring force connections, max. 1.5 mm²
- Max. power consumption: See table below

Variant	Motor	VA			
		Default	+1 valve actuator	+2 valve actuator	+3 valve actuator
Normal	5 Nm	8	15	22	29*
	10 Nm				
	15 Nm				
Spring return	5 Nm	12	19	26*	30*
	10 Nm				
	20 Nm				

*Applies to products with CU ver. 2, delivered from 10/01/2019

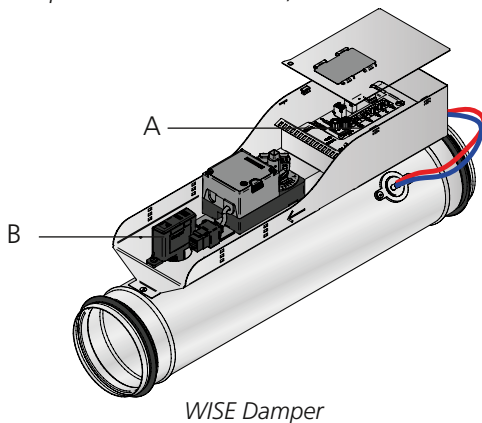

WISE Damper

WISE Damper

A. WISE CU - Controller Unit

- Connection of the power supply
- Connection of the valve actuator for heating and cooling (accessory)

B. WISE SMA - Sensor Module Advanced (option)

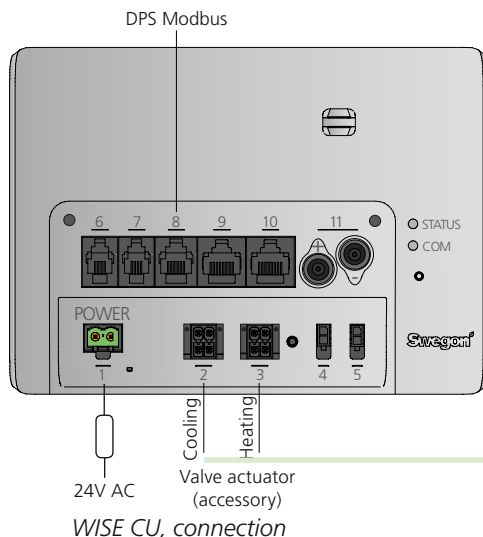

DPS Modbus

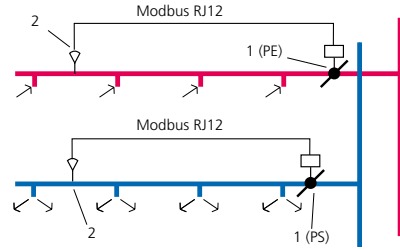

Constant pressure regulation, recommended installation 2/3 out in duct, max 100 m, 1: WISE Damper, 2: WISE DPS Modbus

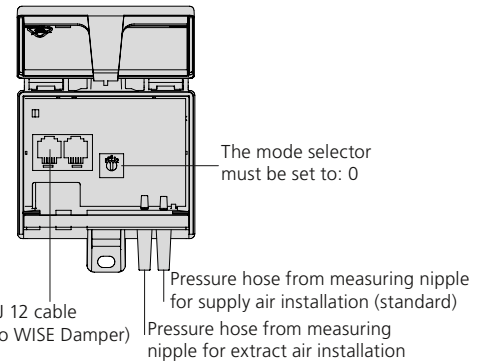

Connection example WISE Damper (terminal 2 cooling, terminal 3 heating)

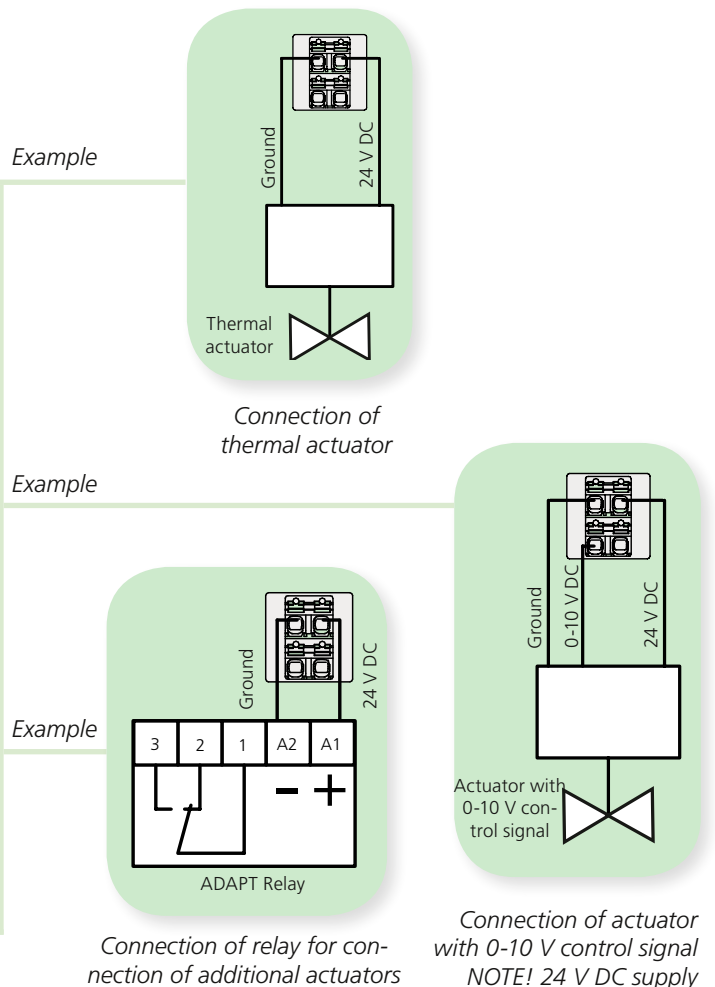

WISE Measure 

Measurement unit with integrated radio module, measures air flow and duct temperature.

Electrical data

Power supply:	24V AC \pm 15% 50 - 60Hz
Connections pipe dim.	
Power:	Screw terminal max. 2.5mm ²
Max. power consumption:	3 VA

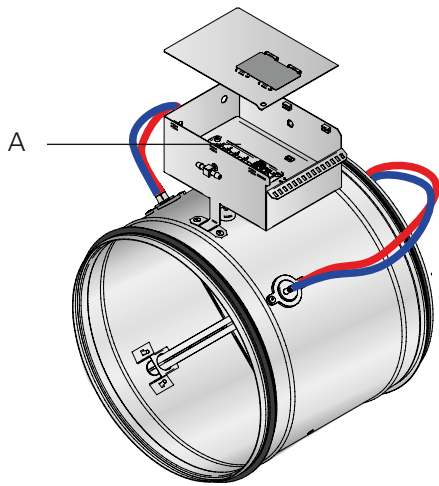

WISE Measure

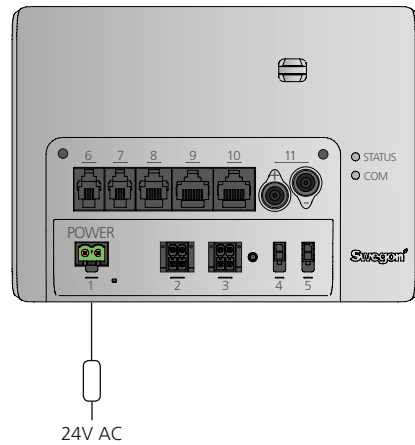

WISE CU, power supply connection

WISE Measure

A. WISE CU - Controller Unit

- Connection of the power supply

System products

The wall mounted system products in WISE are available in different designs. Some are powered by 24 V power supply while some are fitted with a battery and can be chosen to use a power supply OR battery.

NOTE: function for combined power supply and battery operation is not available.

All products communicate wirelessly via radio technology to the WISE system.

Overview - power supply

WISE RTA	
WISE IAQ	
WISE IRT	
WISE OCS	
WISE IORE	
WISE IRE	
WISE WCS	
WISE RTS	

Remove the front-piece

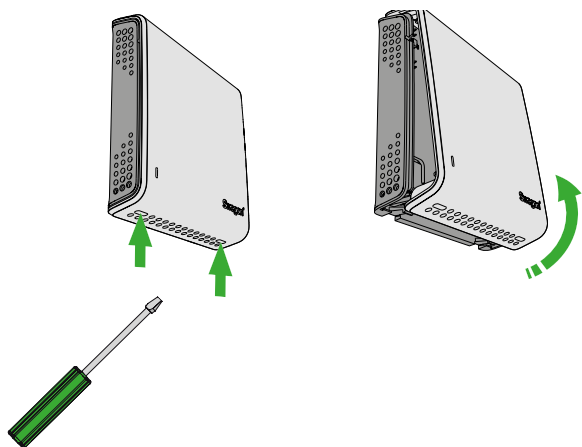

Remove the front-piece

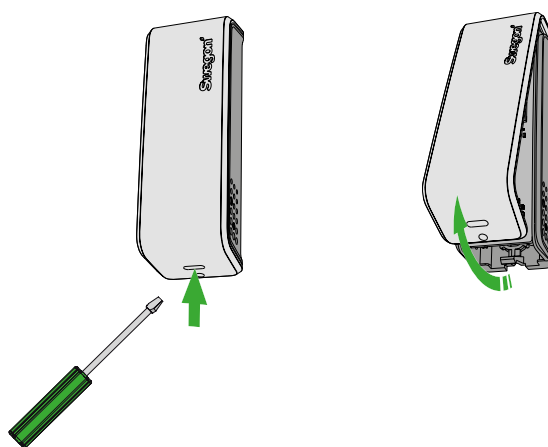

Fit the front-piece

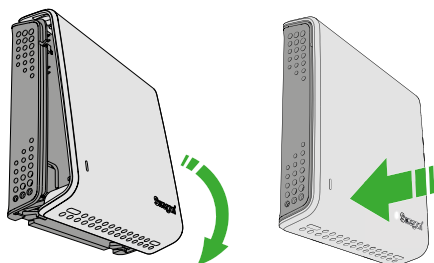

Fit the front-piece

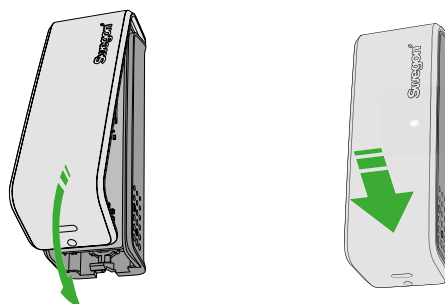

Back piece

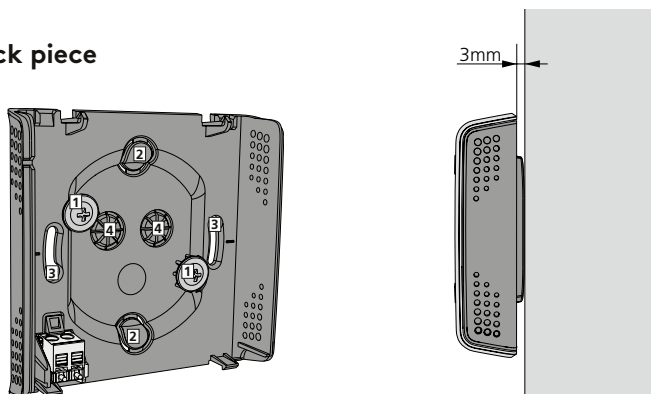

Back piece

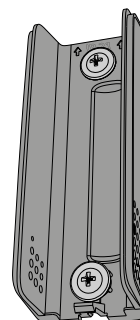

1. Screw mounting on the wall, screw max. Ø4.5 mm, min. length 20 mm, screws not supplied.
2. Knock-outs for cable entry for wall mounting.
3. Hole for mounting in a junction box.
4. Opening for cable entry for mounting in a junction box.

Screw mounting on the wall, screw max. Ø4.5 mm, min. length 20 mm, screws not supplied.

WISE RTA 

WISE RTA is a setpoint adjuster that measures the temperature and has as well as a digital input for connection of e.g. a card reader.

Electrical data

- Power supply: 24V AC $\pm 10\%$ 50-60 Hz, 24V DC (15-30V DC)
- Max. power consumption: 5 VA
- Battery: 2 of the type AA, LiSOCl₂ of 3.6 V (Li-ion)
- Cable rating, connector: Max. 1.5 mm², push-in spring force connection
- External input: 1 digital (open/close or off/on), max. 1.5 mm², push-in spring force connection

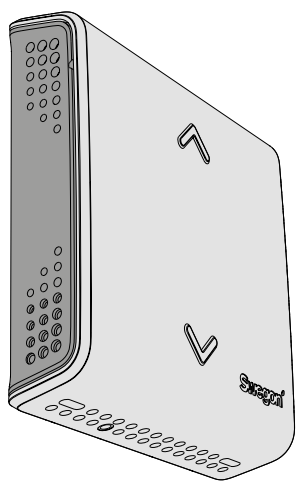

WISE RTA

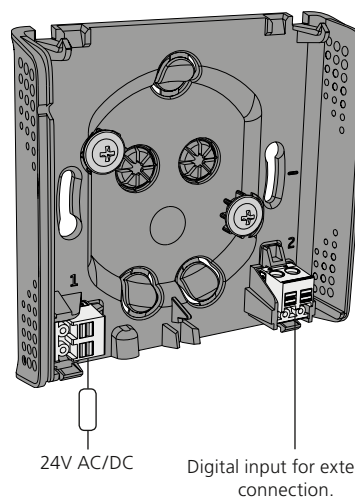

24V AC/DC Digital input for external connection.

WISE RTA - back-piece, power supply and connection

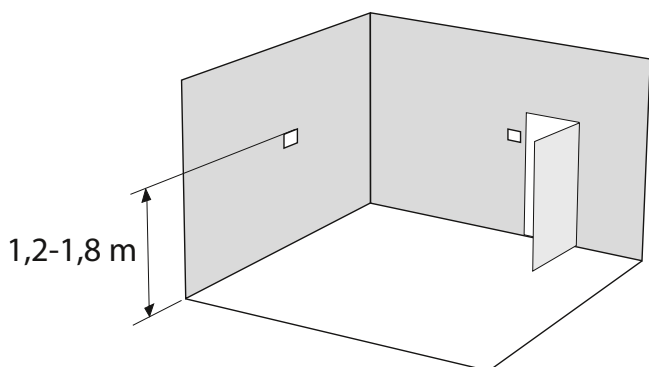

Recommended placement of WISE RTA.

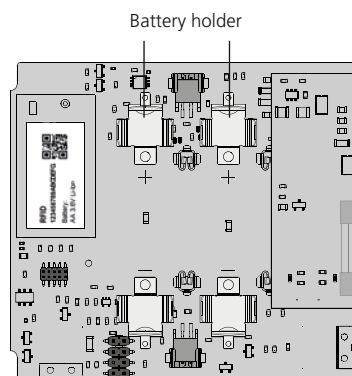

WISE RTA - power supply with battery

WISE IAQ

WISE IAQ is a sensor for wall mounting that measures temperature and air quality in the room.

Electrical data

Power supply:	24 V AC \pm 10% 50-60 Hz, 24V DC (15-30V DC)
Max. power consumption:	2 VA
Cable rating, connector:	Max. 1.5 mm ² , push-in spring force connection

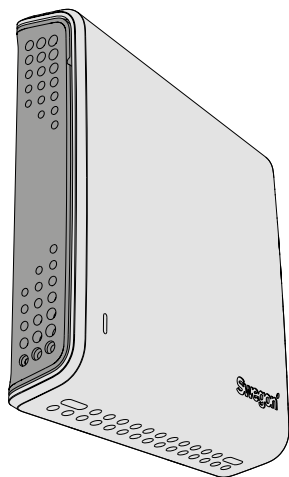

WISE IAQ

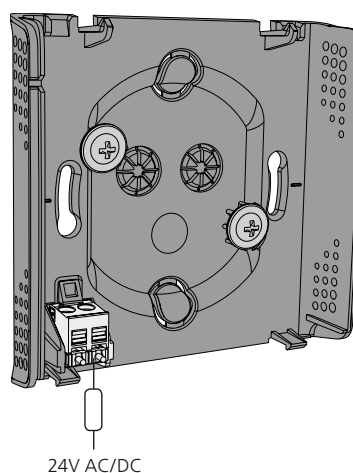

WISE IAQ - back-piece, power supply

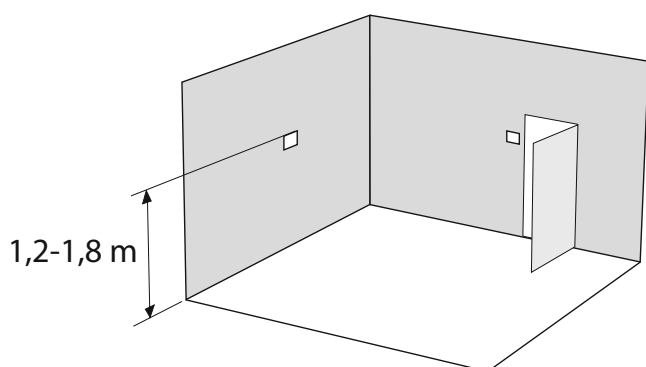

Recommended placement of WISE IAQ

WISE IRT  / 

WISE IRT is a temperature sensor for wall mounting that measures the temperature in the room and the surface temperature on the floor.

Electrical data

Power supply:	24V AC $\pm 10\%$ 50-60 Hz, 24V DC (15-30V DC)
Max. power consumption:	5 VA
Battery:	1 of the type AA, LiSOC12 of 3.6 V (Li-ion)
Cable rating, connector:	Max. 1.5 mm ² , push-in spring force connection

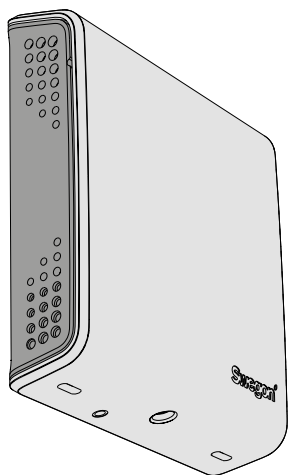

WISE IRT

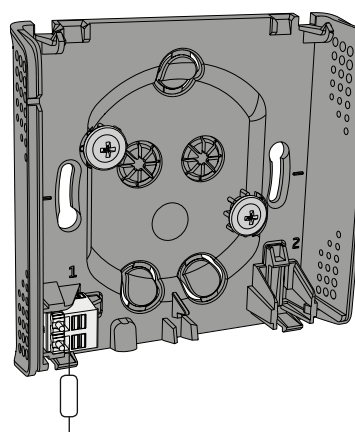

24V AC/DC

WISE IRT - back-piece, power supply

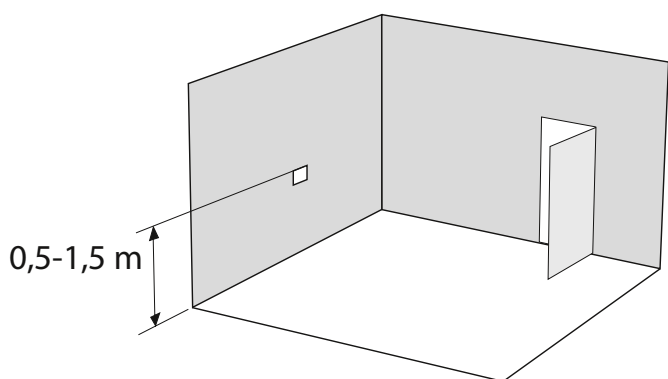

Recommended placement of WISE IRT

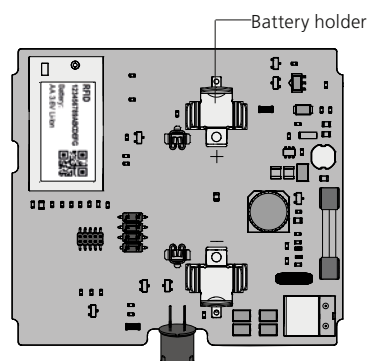

WISE IRT - power supply with battery

WISE OCS 

WISE OCS is a combined sensor. The unit has a PIR sensor to detect occupancy and sensors to measure air humidity and temperature.

Electrical data

Power supply:	24 V AC \pm 10% 50-60 Hz, 24V DC (15-30V DC)
Max. power consumption:	1 VA
Cable rating, connector:	Max. 1.5 mm ² , push-in spring force connection

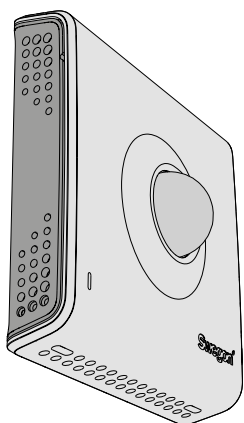

WISE OCS

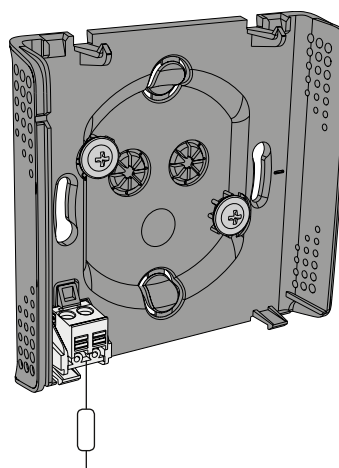

24V AC/DC

WISE OCS - back-piece, power supply

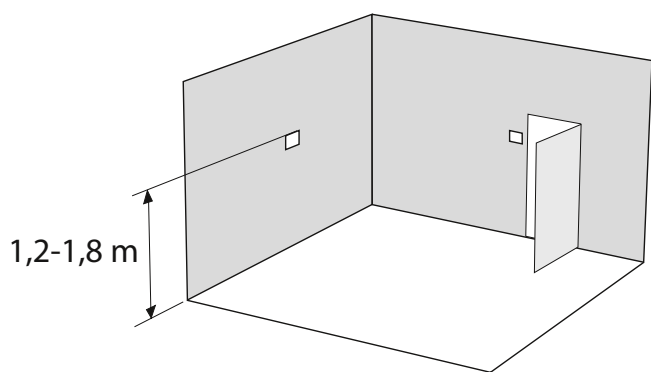

Recommended placement of WISE OCS

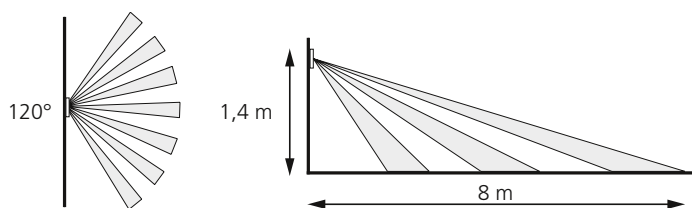

Detection range

WISE IORE 

WISE IORE is a unit that can control products in the system without its own radio communication. The unit can power several valve actuators as long as the total power consumption does not exceed 18 VA. WISE IORE has an analogue input (0-10 V) and input for a condensation sensor.

Electrical data

Power supply:	24 V AC $\pm 10\%$ 50-60 Hz, 24V DC (15-30V DC)
Max. power consumption:	25 VA
Max. power output:	18 VA
Cable rating, connector:	Max. 1.5 mm ² , push-in spring force connection

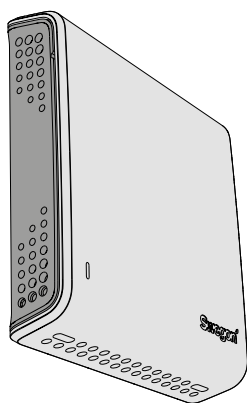

WISE IORE

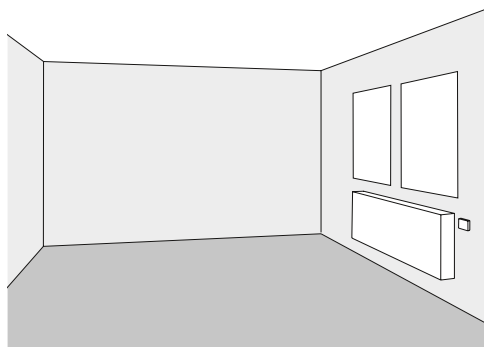

Recommended placement of WISE IORE when controlling radiators

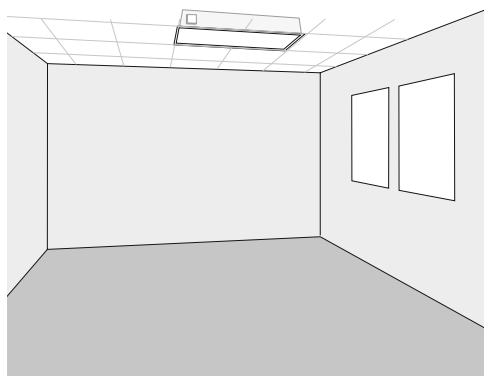

Placement of WISE IORE, installed on a waterborne product without radio communications

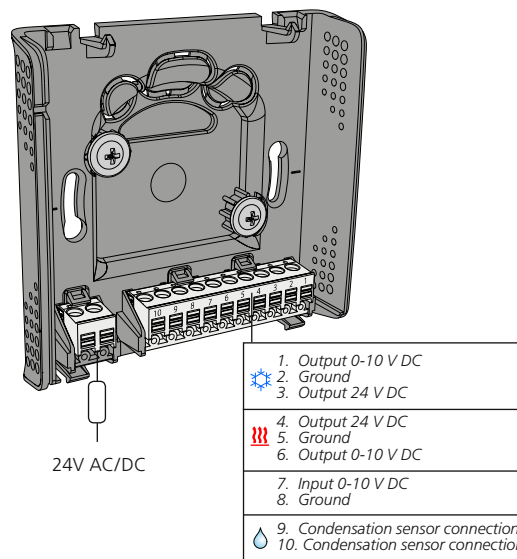

WISE IORE - back-piece, power supply and connection

Connection example WISE IORE

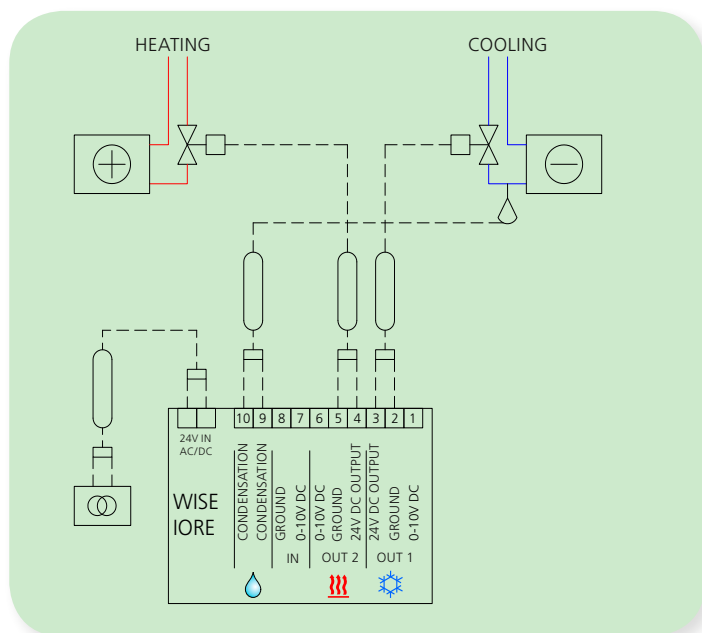

IORE controlling heating and cooling thermo-actuator and condensation sensor

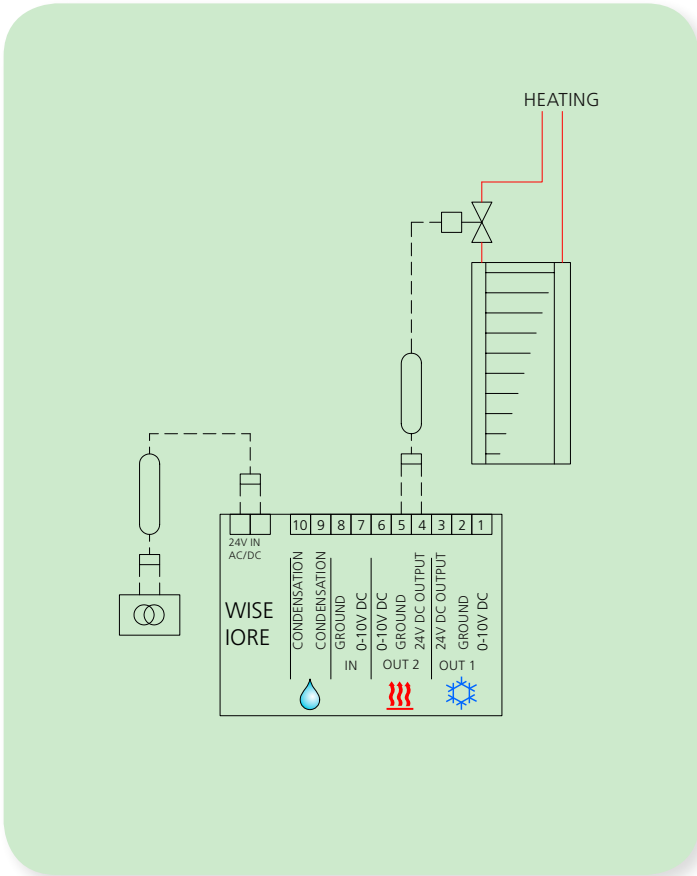

IORE controlling radiator heating 1 thermo-actuator

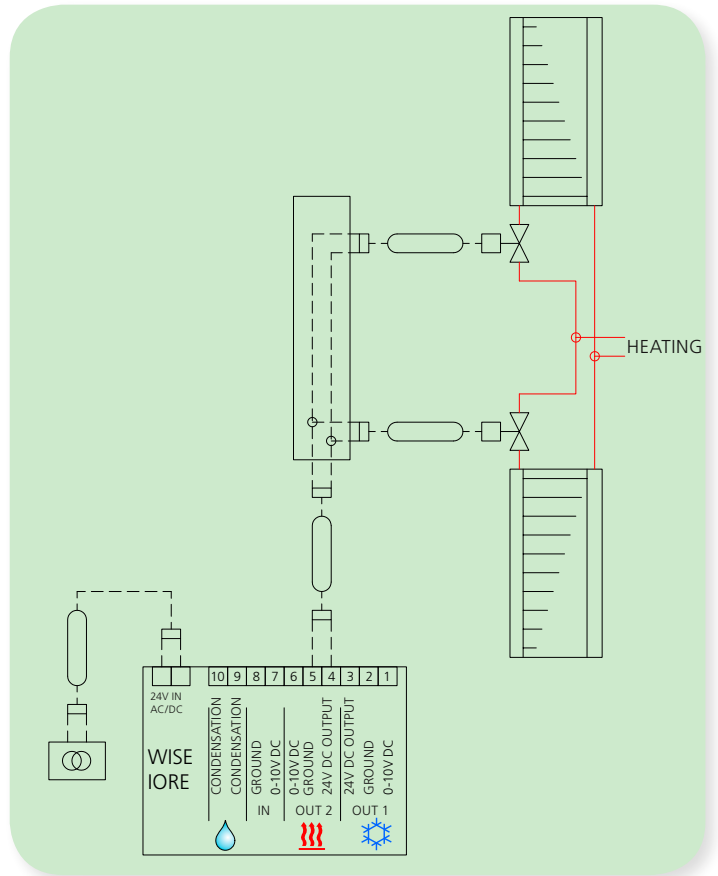

IORE controlling radiator heating 2 thermo-actuators

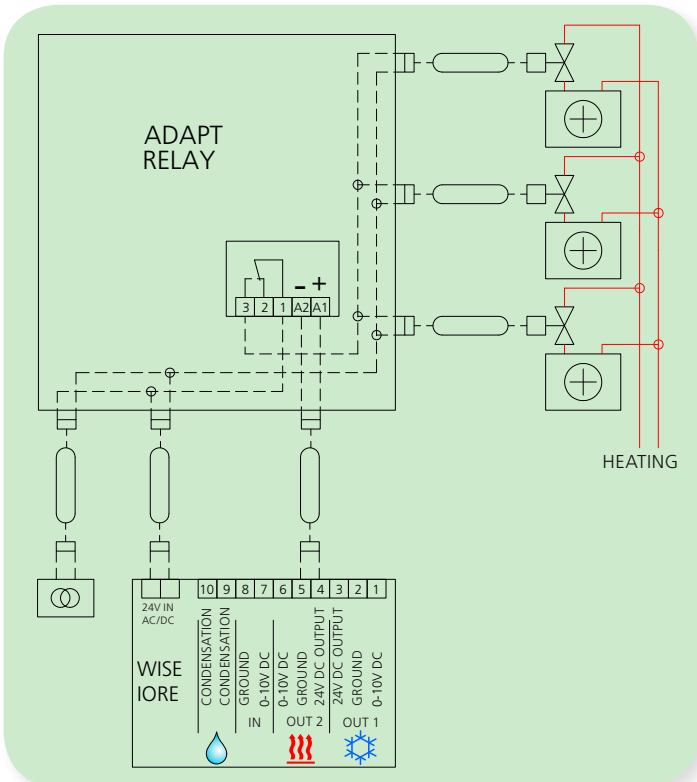

IORE controlling radiator heating 3 or more thermo-actuators

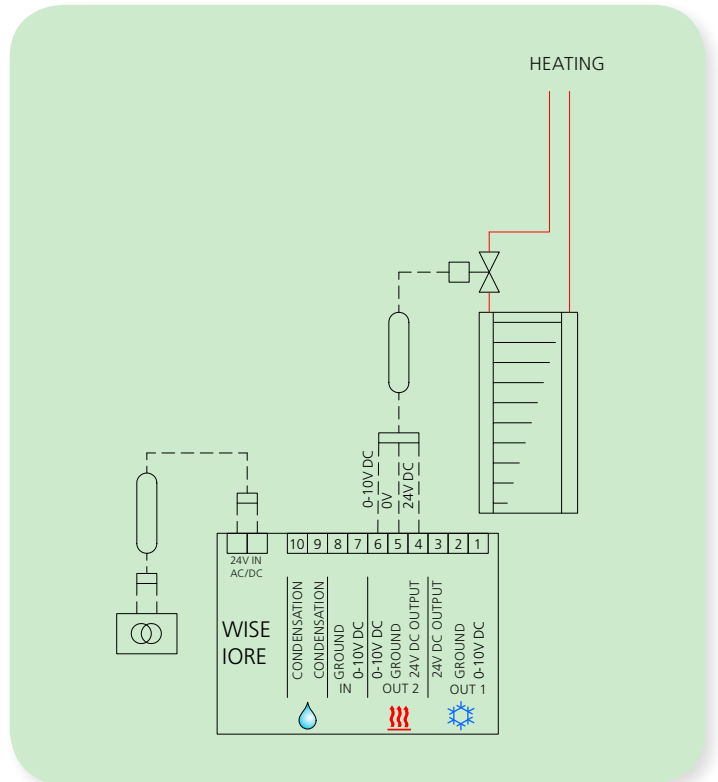

IORE controlling radiator heating 0-10 V

WISE IRE  / 

WISE IRE can take in analogue/digital signals from different sensors in the system that are not equipped with radio communications, and send these wirelessly to WISE DIR. For supplying with 24 V, WISE IRE can also be used as a communication bridge. When two nodes have limited radio communications, WISE IRE is placed between these and boosts communications.

Electrical data

Power supply:	24V AC \pm 10% 50-60 Hz, 24V DC (15-30V DC)
Max. power consumption:	1 VA
Battery:	1 of the type AA, LiSOC12 of 3.6 V (Li-ion)
Cable rating, connector:	Screw terminal max. 1.5mm ²
External input:	1 digital (open/close or off/on) or analogue 0-10 V DC

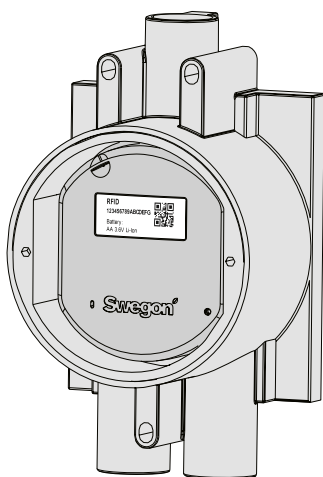

Placement of WISE IRE in junction box

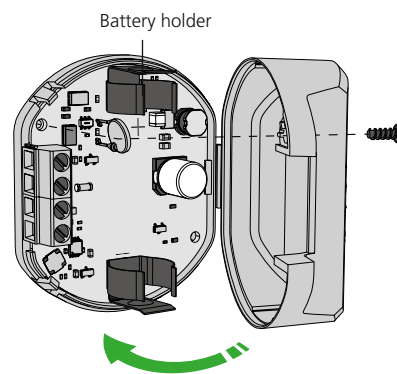

WISE IRE - power supply with battery

WISE IRE - Connection for the external supply voltage

WISE IRE - Connection for supply voltage via battery

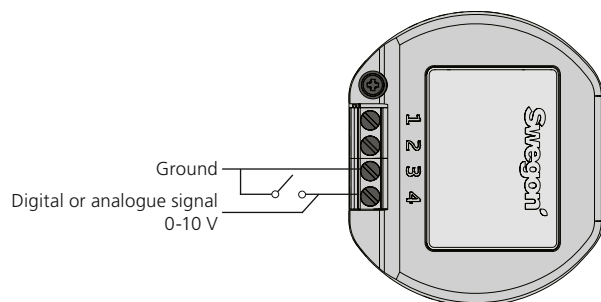
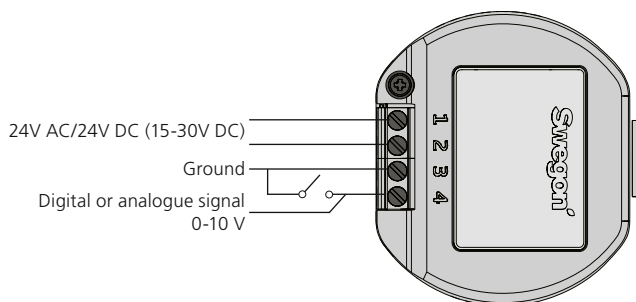

1. Connection of the power supply G0 0V AC / -0V DC
2. Connection of the power supply G 24V AC/DC
3. Ground
4. Digital or analogue signal 0-10 V

1. Not used with battery power
2. Not used with battery power
3. Ground
4. Digital or analogue signal 0-10 V

NOTE! Terminals 1 and 3 are connected inside WISE IRE. It is important to check the connection of the power supply so that the potential on the ground is correct.

WISE WCS

WISE WCS is a window contact that consists of a main part and a magnetic part. It detects whether the window or door where it is installed is open. If this happens contact between the parts is broken and a signal is sent to the WISE system to activate the required functions. The unit communicates wirelessly and is powered by a 3.6 V Lithium-ion battery.

Electrical data

Power consumption: 300 mAh/year

Battery: 1 of the type AA, LiSOCl₂ of 3.6 V (Li-ion)

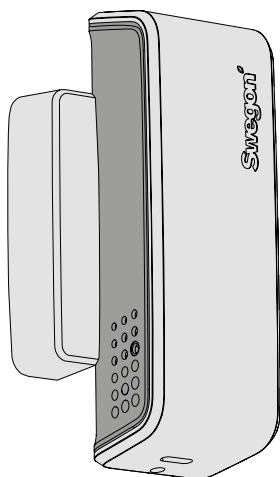

WISE WCS

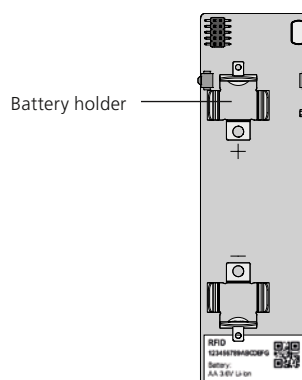

WISE WCS - power supply with battery

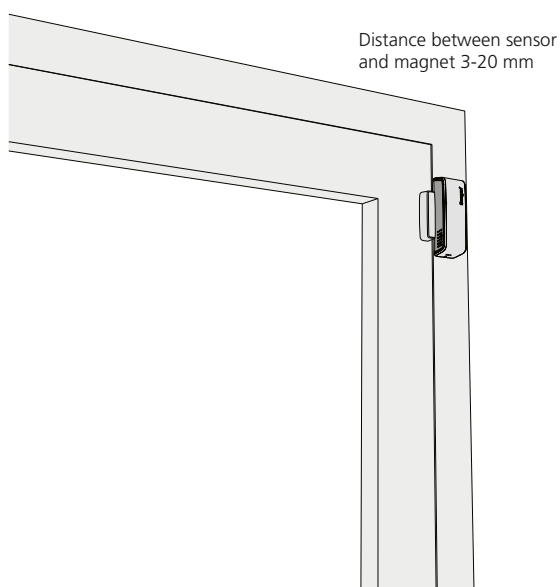

Recommended placement of WISE WCS

WISE RTS 

WISE RTS is a wireless temperature sensor for wall mounting. The unit communicates wirelessly and is powered by a 3.6 V Lithium-ion battery.

Electrical data

Power consumption: 240 mAh/year

Battery: 1 of the type AA, LiSOCl2 of 3.6 V (Li-ion)

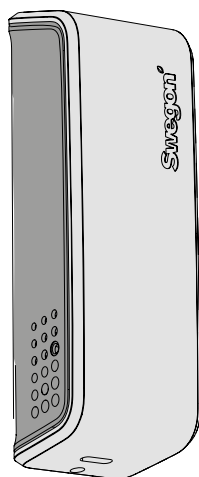

WISE RTS

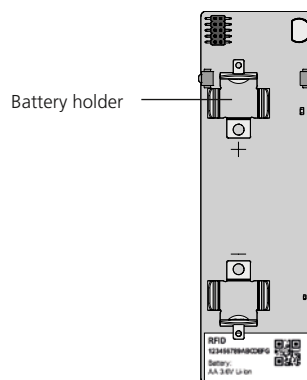

WISE RTS - power supply with battery

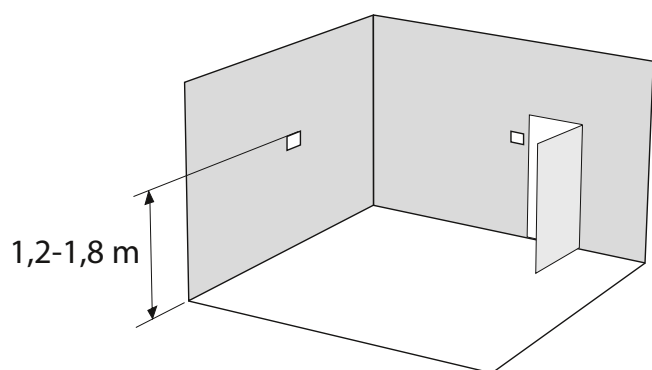

Recommended placement of WISE RTS

Electrical project planning examples

Offices with airborne climate

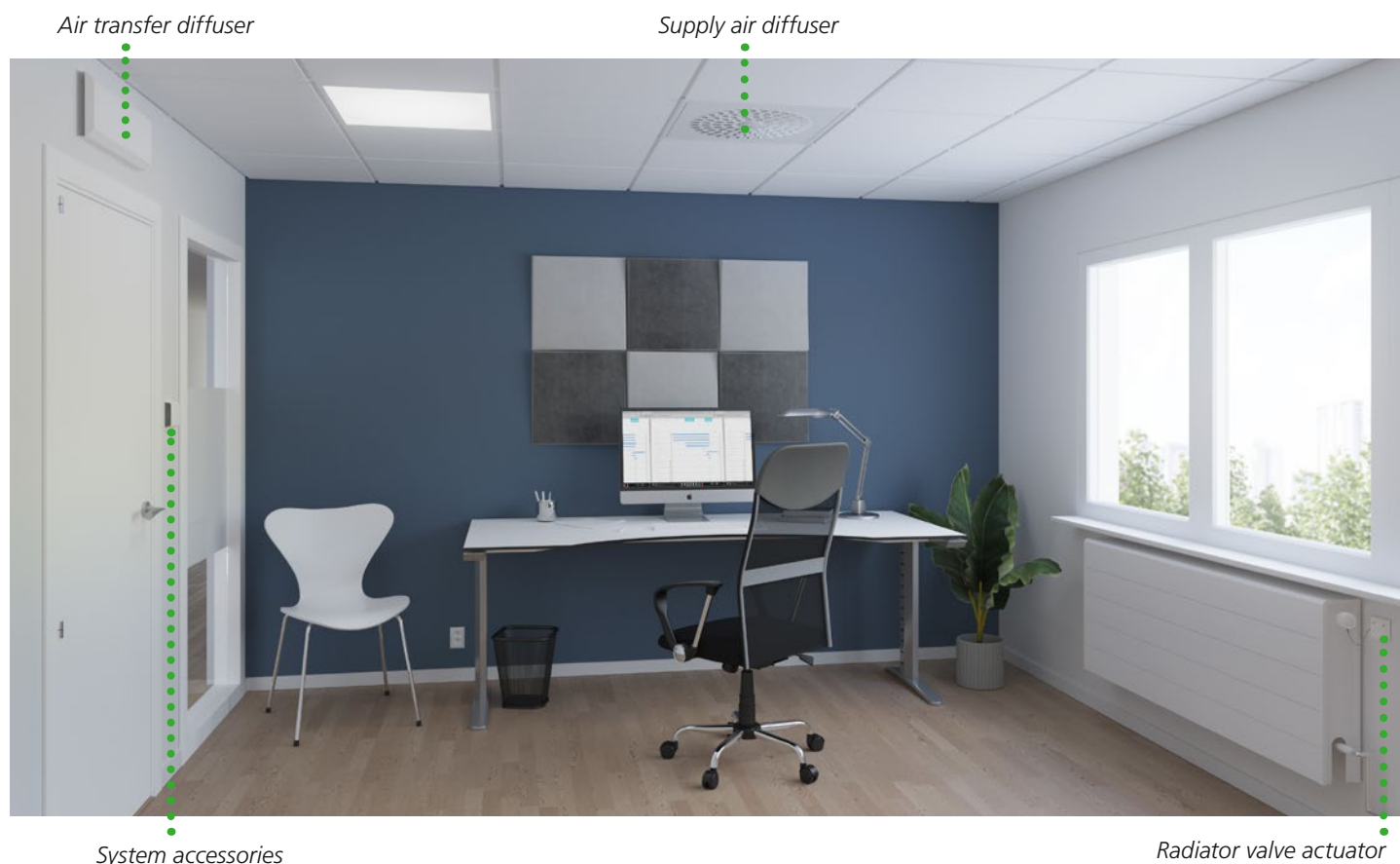

VA-consumption products this example

WISE Colibri Ceiling:	8 VA / pcs
Accessories	
Radiator actuator:	7 VA / pcs
WISE IAQ, air quality, temperature and humidity sensor:	2 VA
WISE RTA, temperature sensor and setpoint adjuster:	5 VA
WISE RTS, temperature sensor:	0 VA (battery)
WISE WCS, window contact:	0 VA (battery)

Sum of the combined maximum consumption (VA) from the selected products and accessories should be used when selecting the transformer.



Installation must be carried out by a qualified electrician and depending on how cable routing in the room is carried out an appropriate cable cross-section must be used. National regulations must be observed.

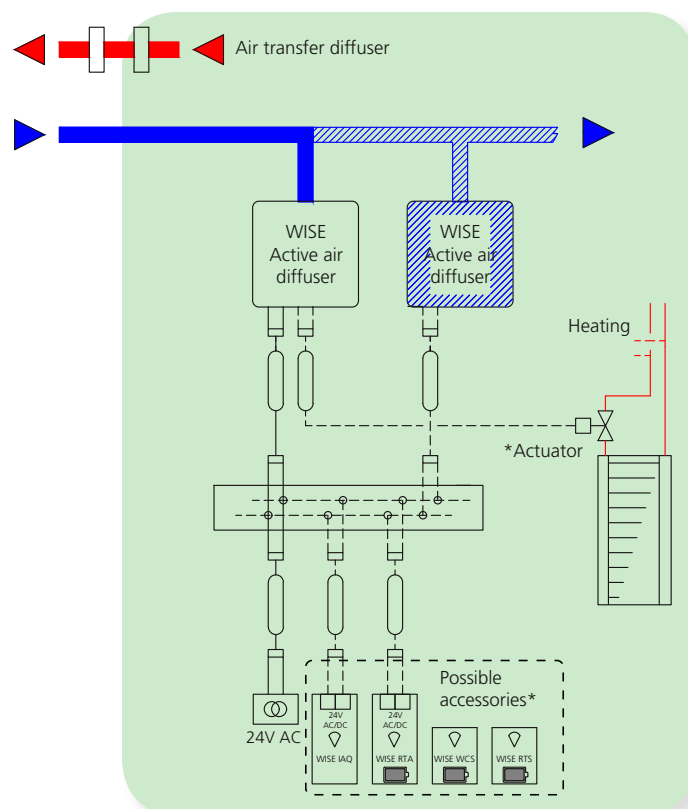

Office with waterborne climate CAV

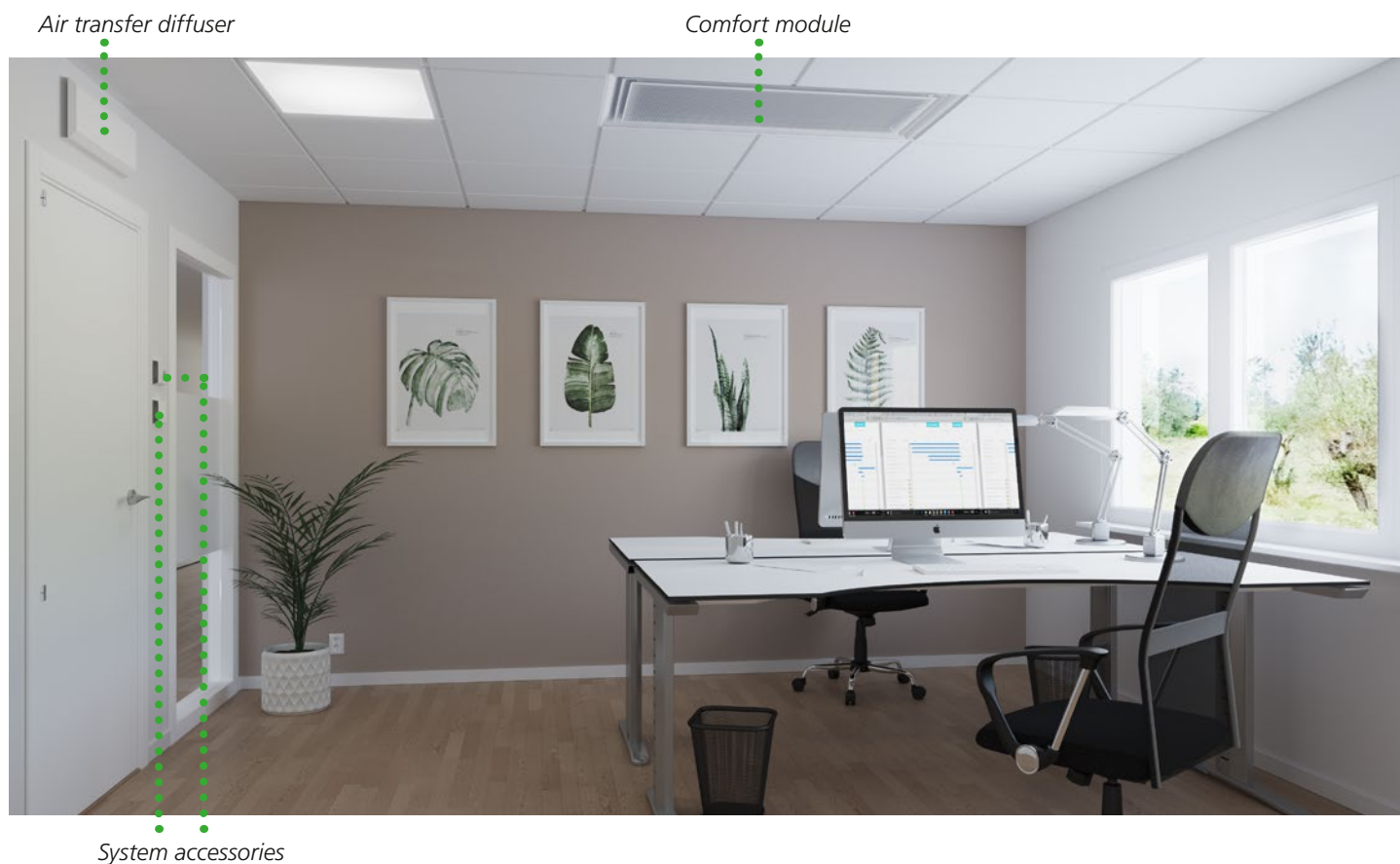

VA-consumption products this example

PARASOL Zenith

WISE IORE, input/output unit: 5 VA

Cooling and heating actuator: 7 VA / pcs

Accessories

Condensation sensor CG-IV: 0 VA

WISE OCS, presence detector incl. temperature and humidity sensor: 1 VA

WISE RTA, temperature sensor and setpoint adjuster: 5 VA

WISE RTS, temperature sensor: 0 VA (battery)

WISE WCS, window contact: 0 VA (battery)

Sum of the combined maximum consumption (VA) from the selected products and accessories should be used when selecting the transformer.



Installation must be carried out by a qualified electrician and depending on how cable routing in the room is carried out an appropriate cable cross-section must be used. National regulations must be observed.

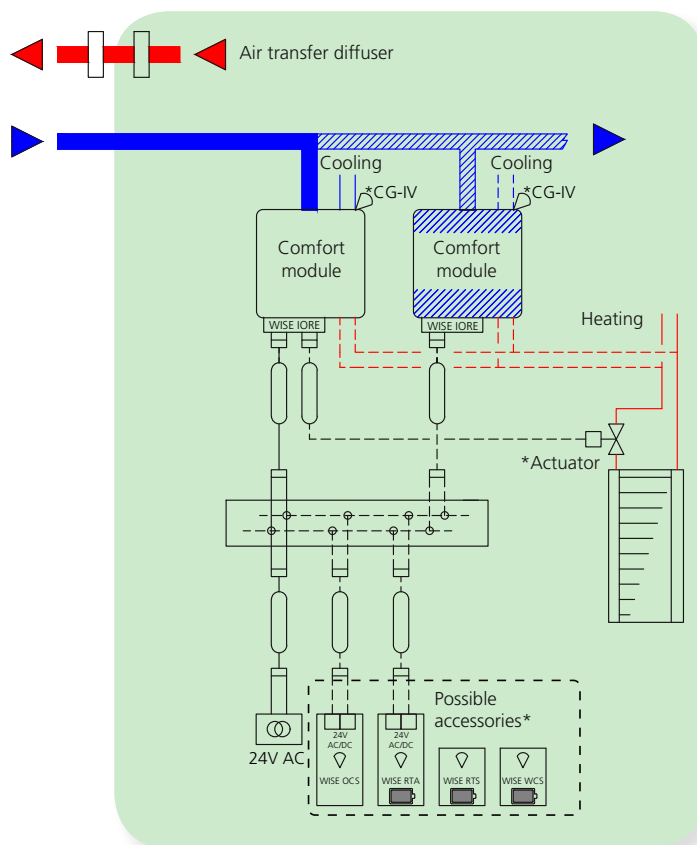

Office with waterborne climate DCV

Air transfer diffuser

Comfort module



System accessories

VA-consumption products this example

WISE Parasol: 5.1 VA

Cooling and heating actuator: 7 VA / pcs

Accessories

Condensation sensor CG-IV: 0 VA

WISE IAQ, air quality, temperature and humidity sensor: 2 VA

WISE RTA, temperature sensor and setpoint adjuster: 5 VA

WISE RTS, temperature sensor: 0 VA (battery)

WISE SMA, Air quality and humidity sensor: 0.8 VA

WISE SMB, sensor module for temperature and presence in comfort module: 0.6 VA

WISE WCS, window contact: 0 VA (battery)

Sum of the combined maximum consumption (VA) from the selected products and accessories should be used when selecting the transformer.



Installation must be carried out by a qualified electrician and depending on how cable routing in the room is carried out an appropriate cable cross-section must be used. National regulations must be observed.

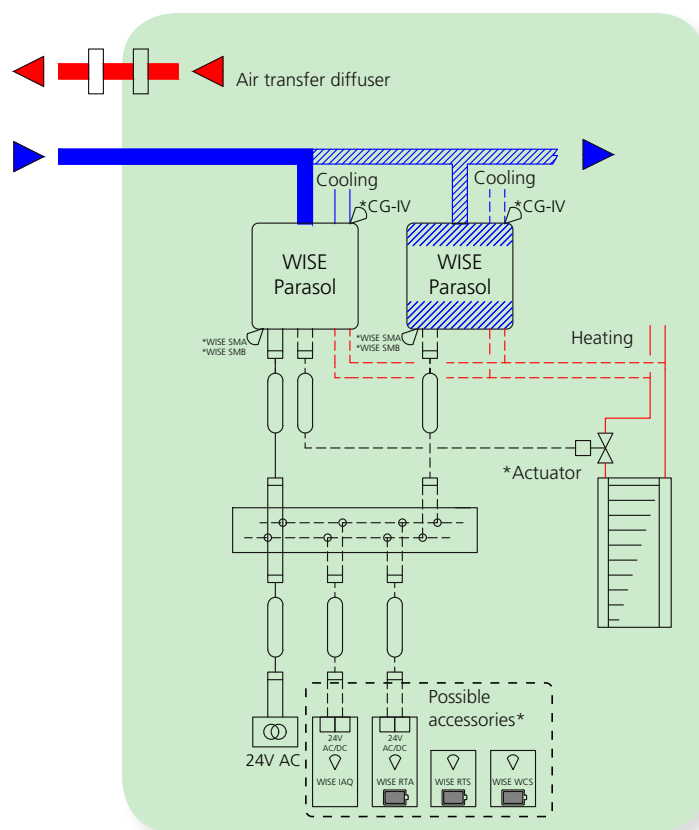

Conference room with water and airborne climate

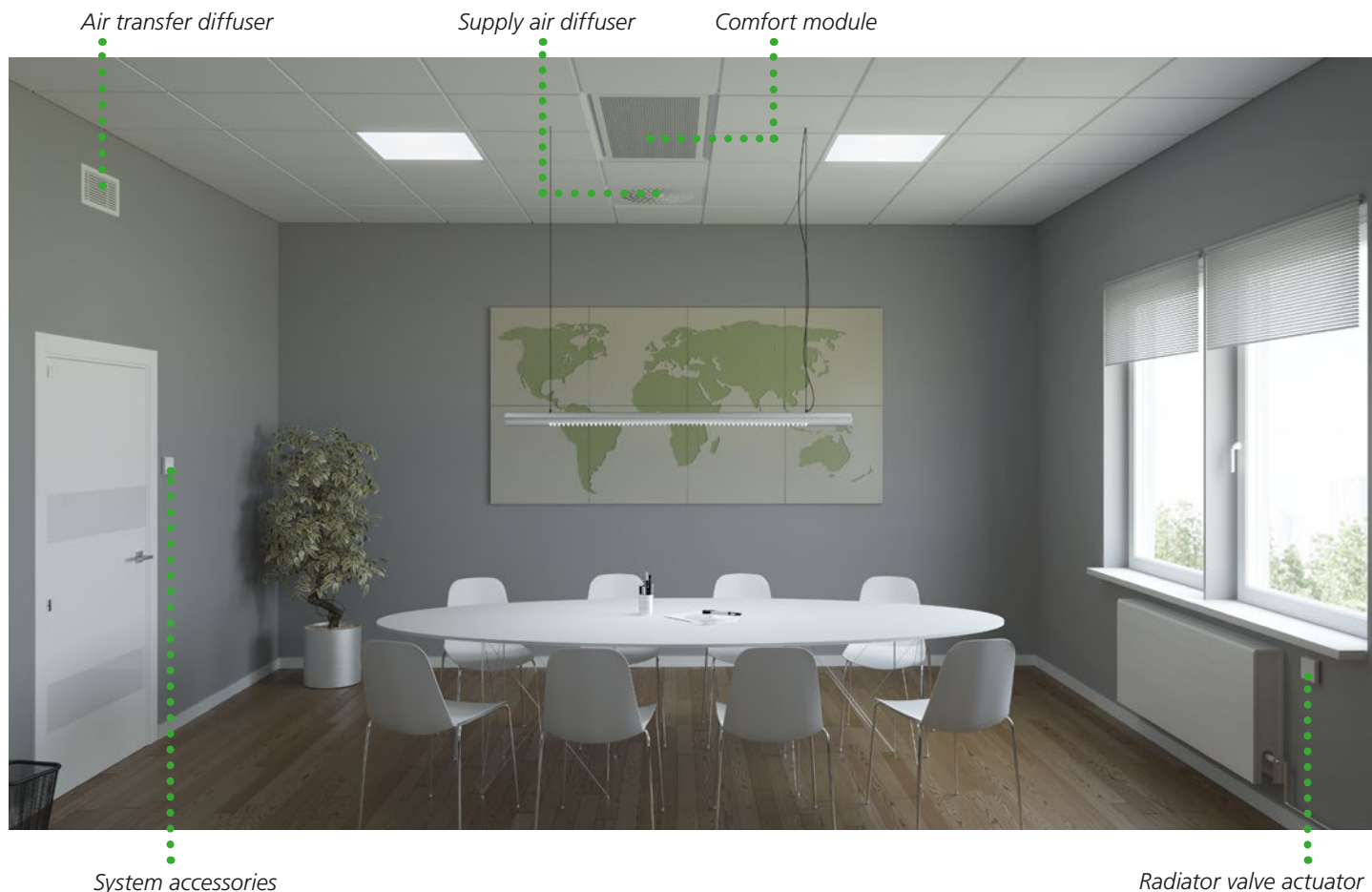

VA-consumption products this example

- WISE Parasol: 5.1 VA / pcs
- Cooling actuator: 7 VA / pcs
- WISE Colibri Ceiling: 8 VA / pcs

Accessories

- Condensation sensor CG-IV: 0 VA
- Radiator actuator/heating actuator: 7 VA / pcs
- WISE IAQ, air quality, temperature and humidity sensor: 2 VA
- WISE RTA, temperature sensor and set-point adjuster: 5 VA
- WISE RTS, temperature sensor: 0 VA (battery)
- WISE SMA, Air quality and humidity sensor: 0.8 VA
- WISE SMB, sensor module for temperature and presence in comfort module: 0.6 VA
- WISE WCS, window contact: 0 VA (battery)

Sum of the combined maximum consumption (VA) from the selected products and accessories should be used when selecting the transformer.



Installation must be carried out by a qualified electrician and depending on how cable routing in the room is carried out an appropriate cable cross-section must be used. National regulations must be observed.

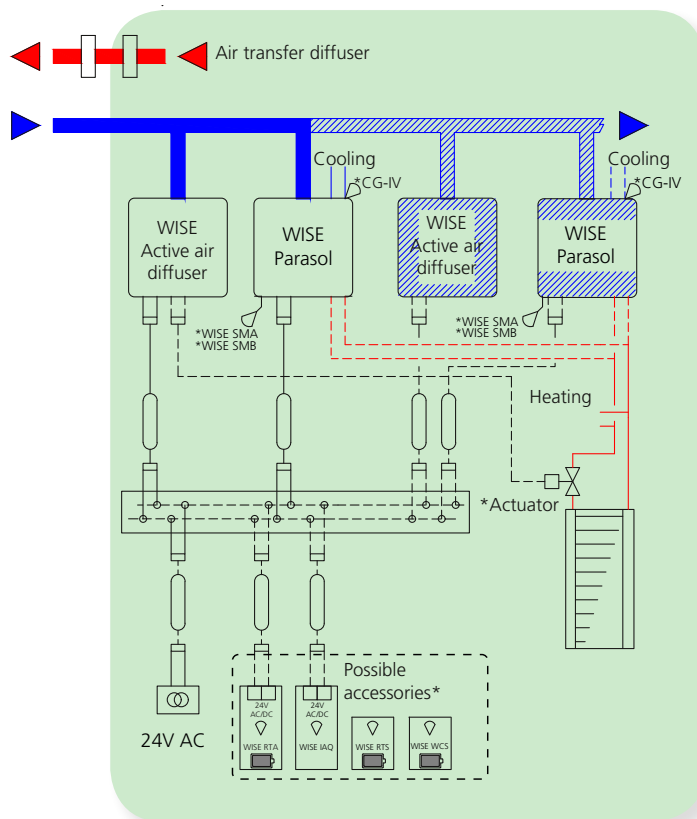

Office with airborne climate in balance



VA-consumption products this example

WISE Colibri Ceiling:	8 VA / pcs
WISE Damper:	8 VA / pcs
Accessories	
Radiator actuator:	7 VA / pcs
WISE IAQ, air quality, temperature and humidity sensor:	2 VA
WISE RTA, temperature sensor and setpoint adjuster:	5 VA
WISE RTS, temperature sensor:	0 VA (battery)
WISE SMA, Air quality and humidity sensor:	0.8 VA
WISE WCS, window contact:	0 VA (battery)

Sum of the combined maximum consumption (VA) from the selected products and accessories should be used when selecting the transformer.



Installation must be carried out by a qualified electrician and depending on how cable routing in the room is carried out an appropriate cable cross-section must be used. National regulations must be observed.

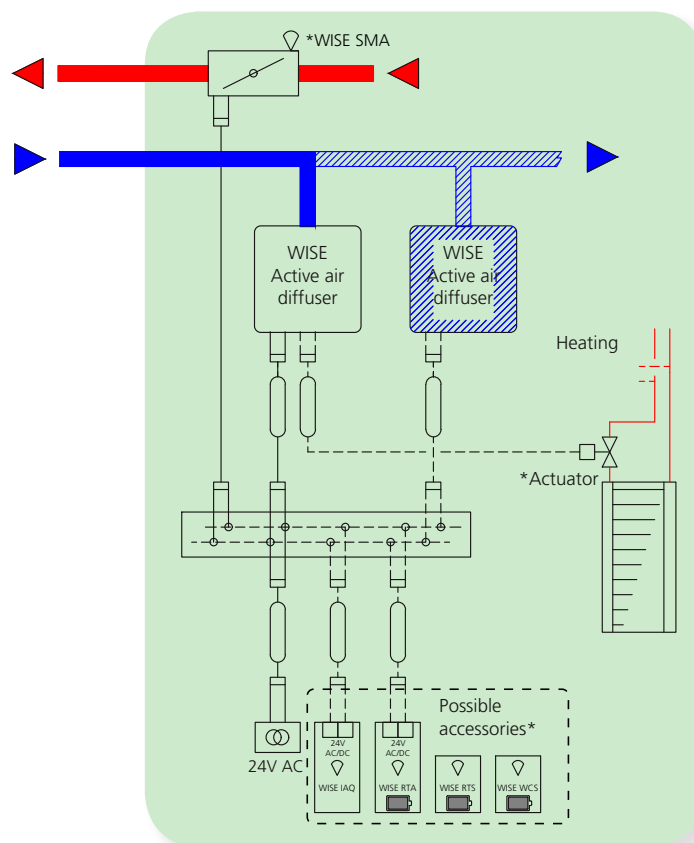

Classroom with airborne climate in balance

Passive extract air diffuser

Passive supply air diffuser



System accessories

Radiator valve actuator

VA-consumption products this example

- WISE Damper supply air: 8 VA
- WISE Damper extract air: 8 VA

Accessories

- Radiator actuator: 7 VA / pcs
- WISE IAQ, air quality, temperature and humidity sensor: 2 VA
- WISE OCS, presence detector incl. temperature and humidity sensor: 1 VA
- WISE RTA, temperature sensor and setpoint adjuster: 5 VA
- WISE RTS, temperature sensor: 0 VA (battery)
- WISE WCS, window contact: 0 VA (battery)

Sum of the combined maximum consumption (VA) from the selected products and accessories should be used when selecting the transformer.



Installation must be carried out by a qualified electrician and depending on how cable routing in the room is carried out an appropriate cable cross-section must be used. National regulations must be observed.

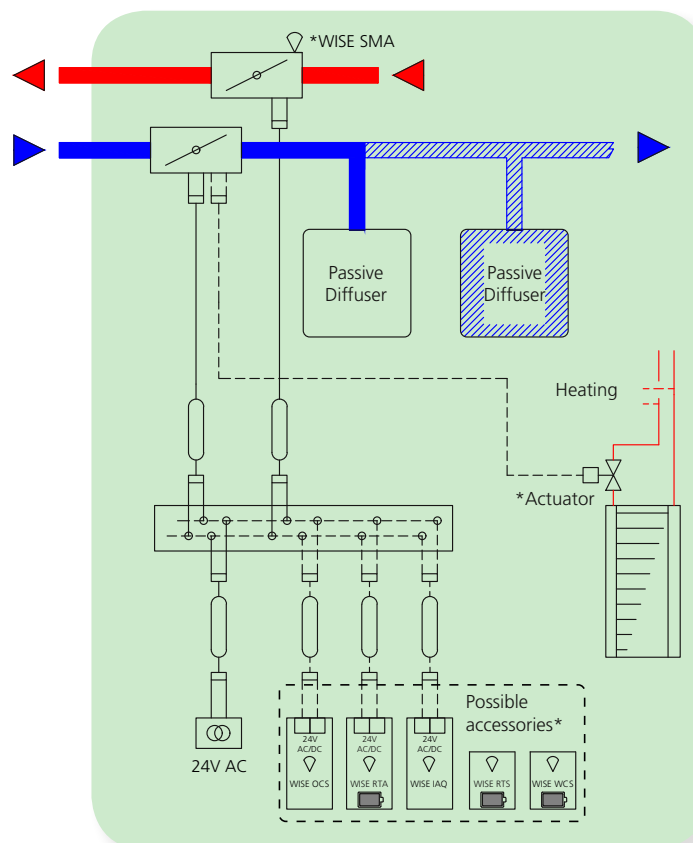

Classroom with airborne climate with fume hood ventilation in balance

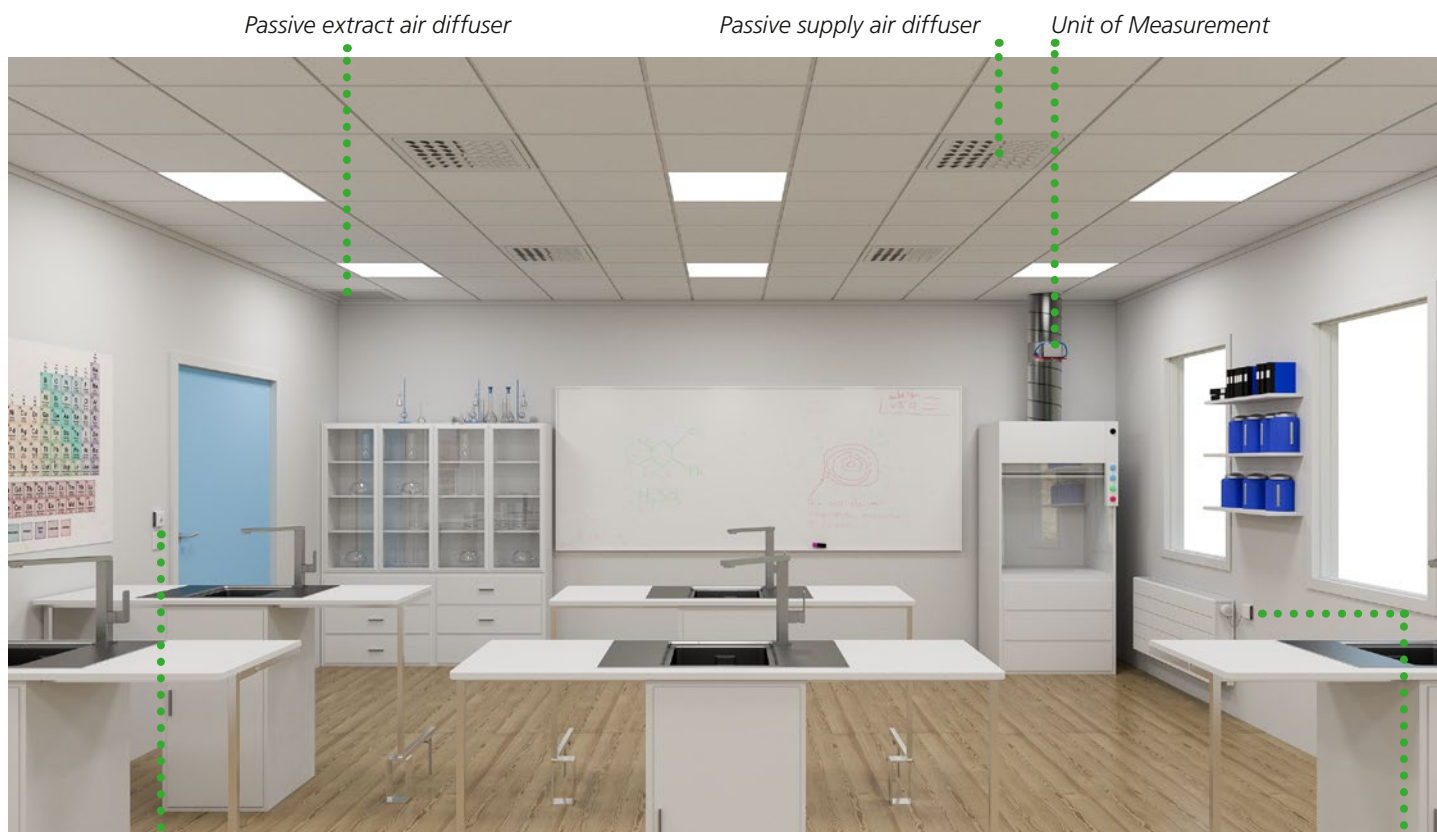

System accessories

Radiator valve actuator

VA-consumption products this example

WISE Damper extract air: 8 VA
 WISE Damper supply air: 8 VA

WISE Measure: 3 VA

Accessories

Radiator actuator: 7 VA / pcs

WISE IAQ, air quality, temperature and humidity sensor: 2 VA

WISE IRE: 1 VA

WISE OCS, presence detector incl. temperature and humidity sensor: 1 VA

WISE RTA, temperature sensor and setpoint adjuster: 5 VA

WISE RTS, temperature sensor: 0 VA (battery)

WISE WCS, window contact: 0 VA (battery)

Sum of the combined maximum consumption (VA) from the selected products and accessories should be used when selecting the transformer.



Installation must be carried out by a qualified electrician and depending on how cable routing in the room is carried out an appropriate cable cross-section must be used. National regulations must be observed.

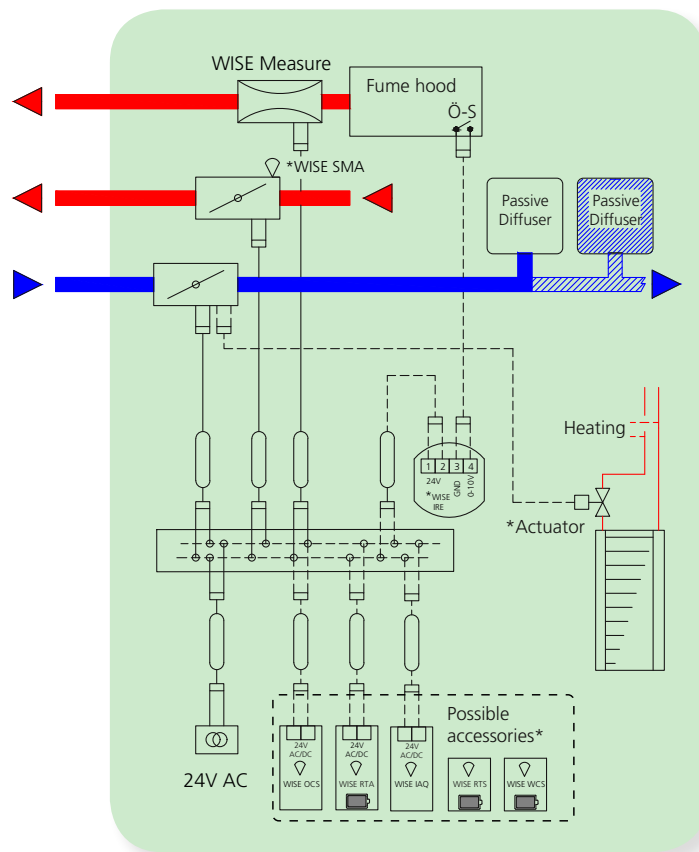

Open-plan office with water and airborne climate with balanced extract air

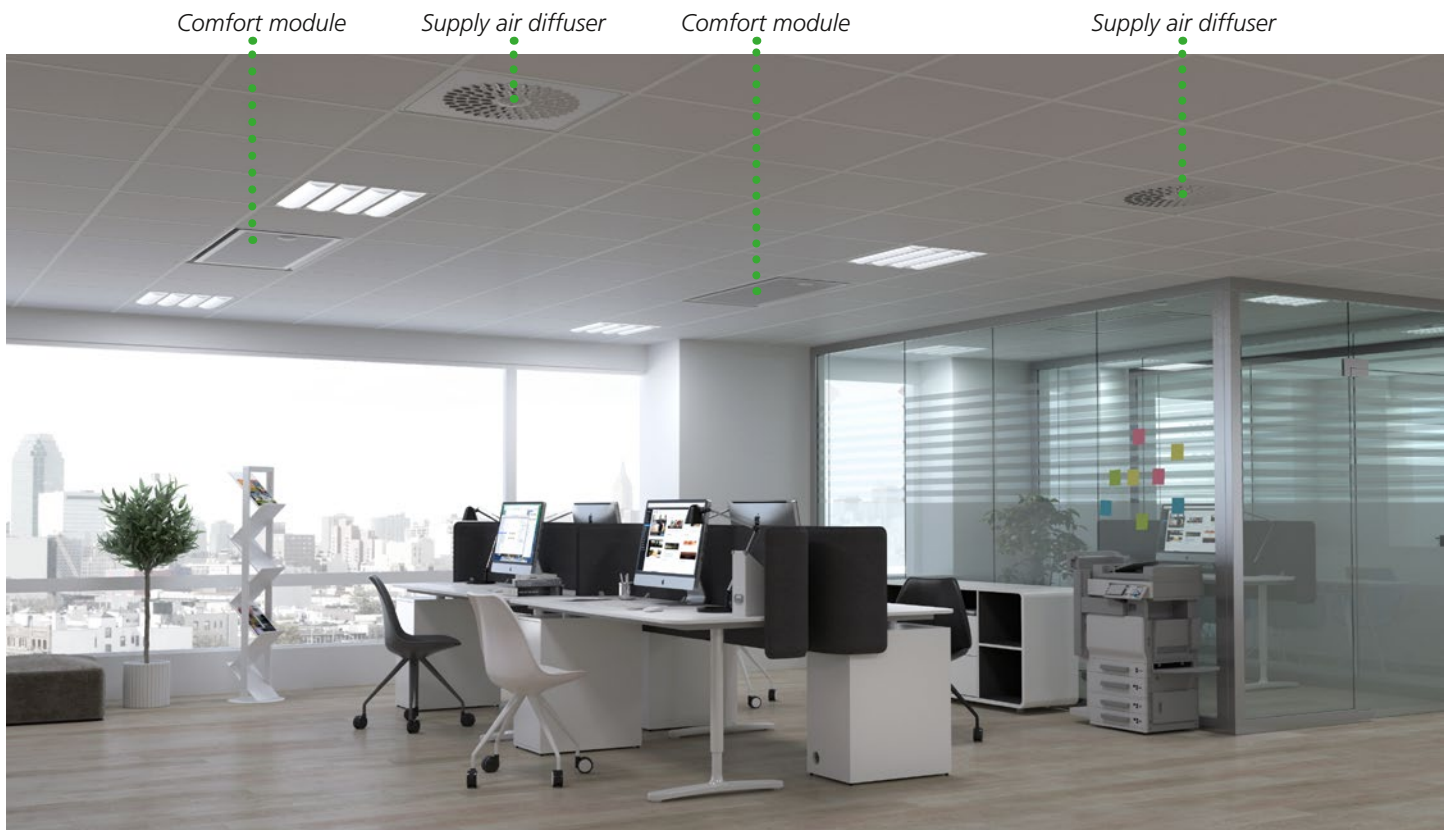

VA-consumption products this example

WISE Colibri Ceiling:	8 VA / pcs
WISE Damper:	8 VA
WISE Parasol:	5.1 VA / pcs
Cooling actuator:	7 VA / pcs

Accessories

Condensation sensor CG-IV:	0 VA
Radiator actuator/heating actuator:	7 VA / pcs
WISE IAQ, air quality, temperature and humidity sensor:	2 VA
WISE IORE, input/output unit:	5 VA
WISE RTA, temperature sensor and setpoint adjuster:	5 VA
WISE RTS, temperature sensor:	0 VA (battery)
WISE SMA, Air quality and humidity sensor:	0.8 VA
WISE SMB, sensor module for temperature and presence in comfort module:	0.6 VA
WISE WCS, window contact:	0 VA (battery)

Sum of the combined maximum consumption (VA) from the selected products and accessories should be used when selecting the transformer.



Installation must be carried out by a qualified electrician and depending on how cable routing in the room is carried out an appropriate cable cross-section must be used. National regulations must be observed.

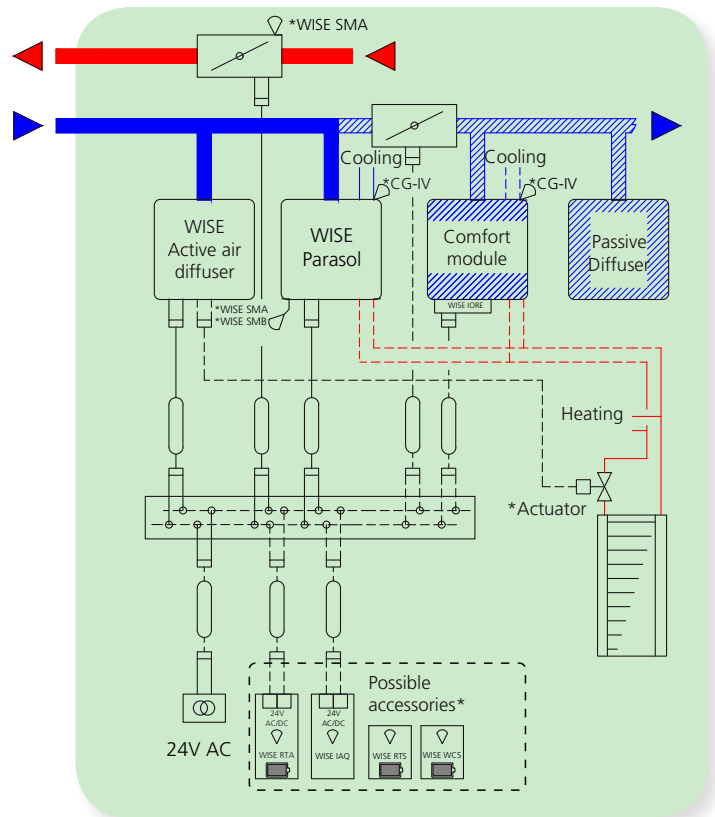

Hotel room

Extract air damper (not pictured),
WISE damper PARAGON

Supply air damper (not pictured),
WISE damper PARAGON

Comfort module for hotel,
PARAGON with WISE CU

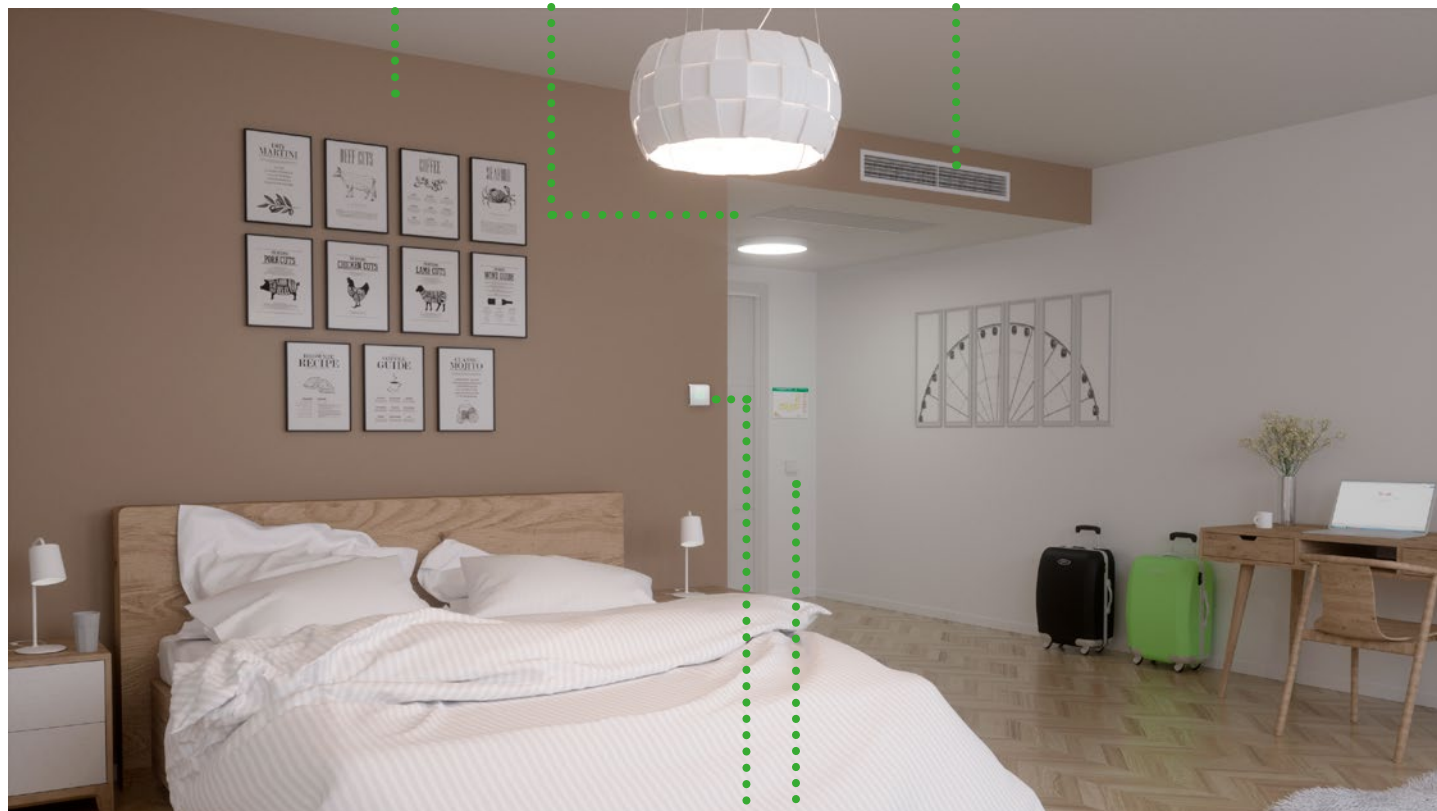

System accessories

Key card holder SYST SENSO II with WISE IRE

VA-consumption products this example

PARAGON

WISE CU: 2.3 VA

PARAGON b T-SAK-VAV-125-WISE: 2 VA

PARAGON b T-EAK-VAV-125-WISE: 2 VA

Cooling and heating actuator: 7 VA / pcs

Accessories

Condensation sensor CG-IV: 0 VA

Key card holder SYST SENSO II: 0 VA

WISE IORE, input/output unit: 1 VA

WISE RTA, temperature sensor and setpoint adjuster: 5 VA

WISE WCS, window contact: 0 VA (Battery)

Sum of the combined maximum consumption (VA) from the selected products and accessories should be used when selecting the transformer.



Installation must be carried out by a qualified electrician and depending on how cable routing in the room is carried out an appropriate cable cross-section must be used. National regulations must be observed.

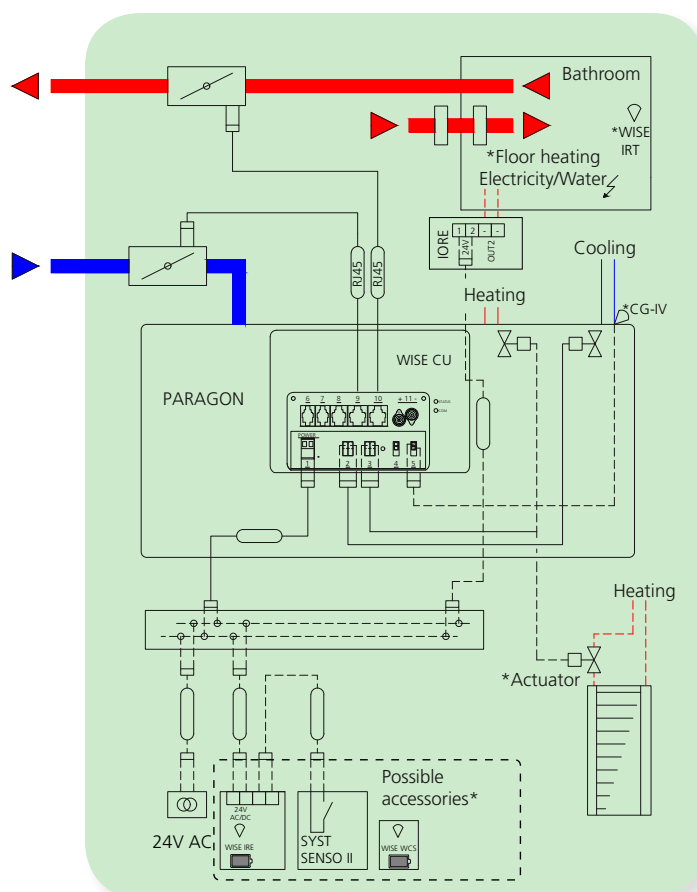

We make every breath count.