



Ultimate Pro Staging 24 Tray Capacity Assembly Instructions

SKU: PLTSM24

IMPORTANT: Please read these instructions thoroughly before starting assembly.
Please check that you have all of the parts listed on the materials section of this manual before commencing assembly. If there are any missing or damaged parts, please call us on 020 3011 2040.

Introduction

Thank you for your purchase of our Standard Staging 24 Tray.

Please read through these instructions and familiarize yourself with the construction before you begin.

We operate a programme of continuous product improvement and we reserve the right to change the specification without prior notice, the latest model is supplied.



Important Information

Please read these instructions thoroughly before starting assembly.

Please check that you have all of the parts listed before starting the assembly.

If there are any damaged or missing parts, please call us on 020 3011 2040.

Keep these instructions in a safe place for future use.

Hints and Tips

1. All the metal parts are identified with the part number stamped towards one end, all other parts can be identified by measuring and comparing to the list of materials in this manual.
2. All framework is assembled with nuts on the inside except where stated.
3. Leave all bolts loose until the assembly is complete, then tighten.
4. Should you have any difficulty in lining up the holes on the framework, use a bradawl to help align the holes.
5. To help you orientate the parts for the framework there are symbols placed alongside the part, see examples below.

Caution

- Take care and wear safety gloves when working with metal parts as some have sharp edges.
- Keep children and pets away from the assembly area.
- Keep the area around your work place area clean and tidy.
- Take care when handling sharp tools and never carry sharp tools in your pocket.
- Never leave your product unattended or partially built, especially outside on a windy day.
- You are advised to take care and wear suitable personal protective equipment such as safety glasses & gloves where possible.

Tools Required

- Flat screwdriver
- Crosshead screwdriver
- 7mm spanner
- Do not use power tools to tighten nuts & bolts

Maintenance

- On completion tighten all nuts and bolts. It is advised that periodically or after storms or gales you check all nuts, bolts and screws, and tighten where necessary.

Parts

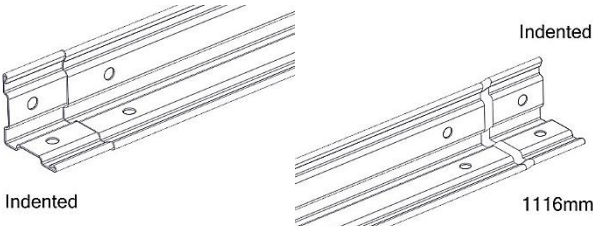
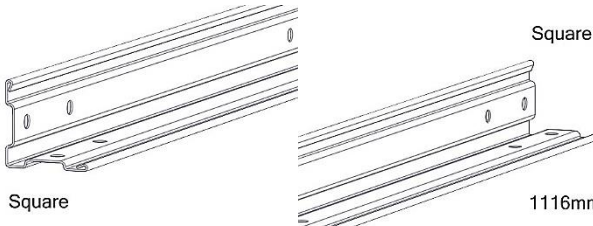
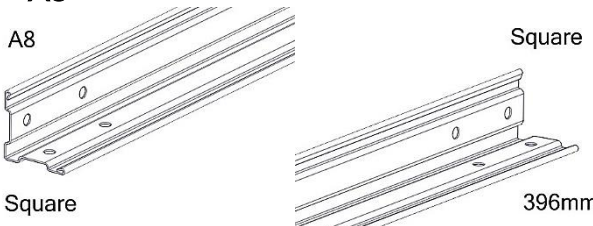

Metal 90° Angles

<p>x 12 - XL33S</p>  <p>Indented</p> <p>Indented</p> <p>1116mm</p>	<p>x 4 - XL33</p>  <p>Square</p> <p>Square</p> <p>1116mm</p>
<p>x 9 - A8</p>  <p>A8</p> <p>Square</p> <p>Square</p> <p>396mm</p>	

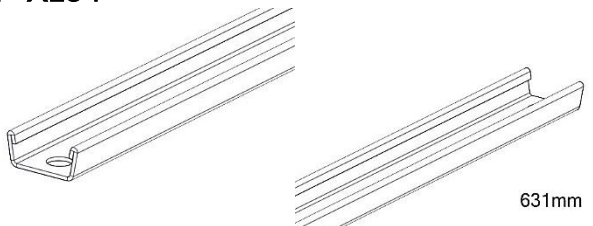
Metal Channels

<p>x 2 - XL34</p>  <p>631mm</p>	
--	--

Fixings

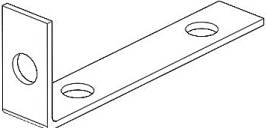
<p>x 63 - 8mm Bolt</p> 	<p>x 63 - Flanged Nut</p> 
<p>x 8 - B2 Bracket</p> 	

End Support Assembly

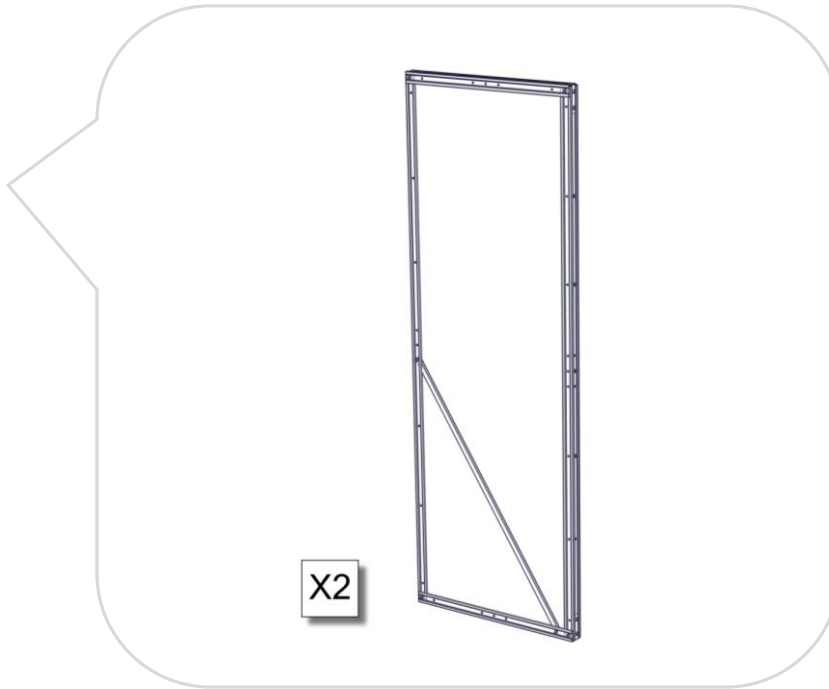

Step 1 - Bolt together end panel frame

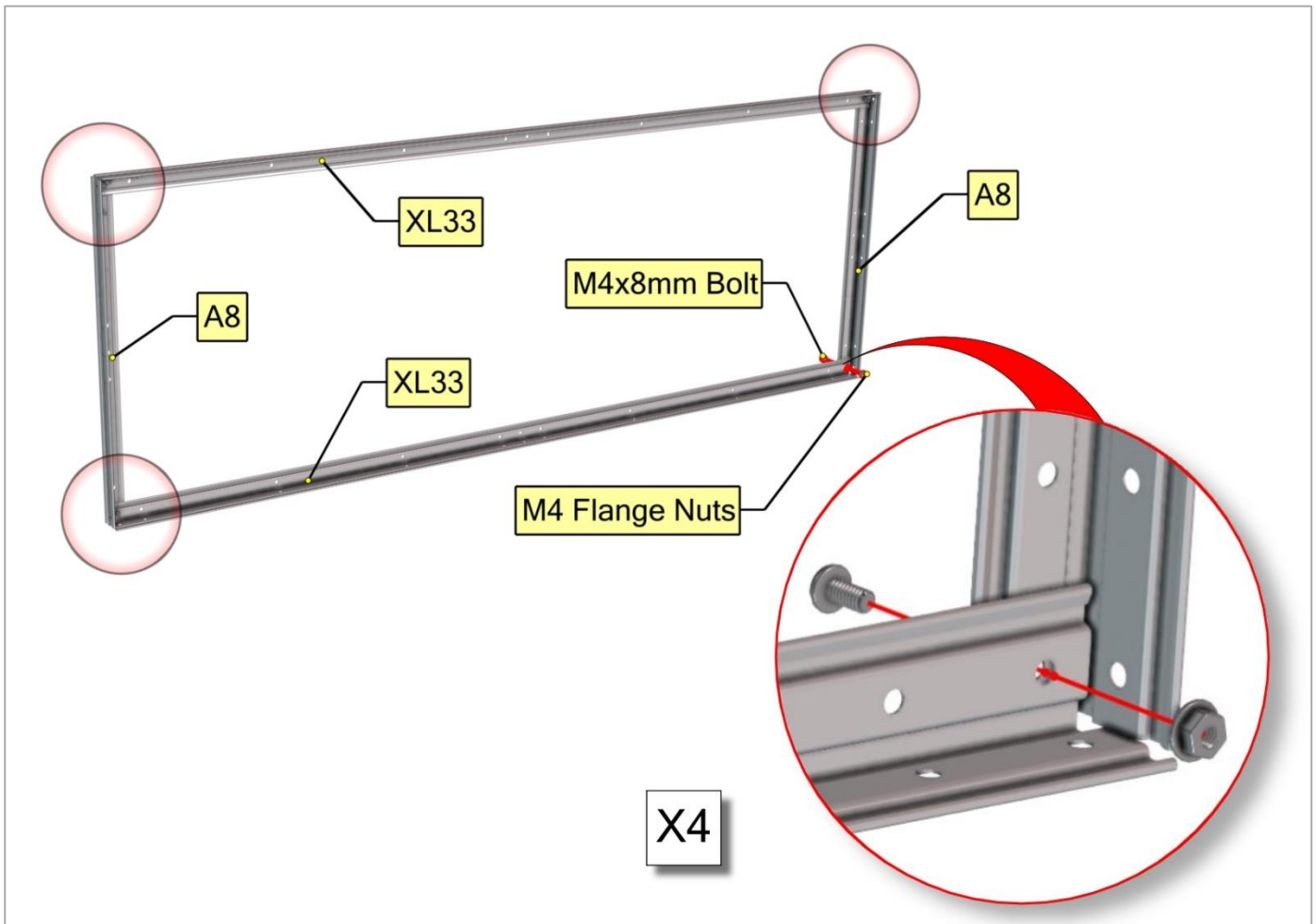

Step 2 - Add diagonal supports

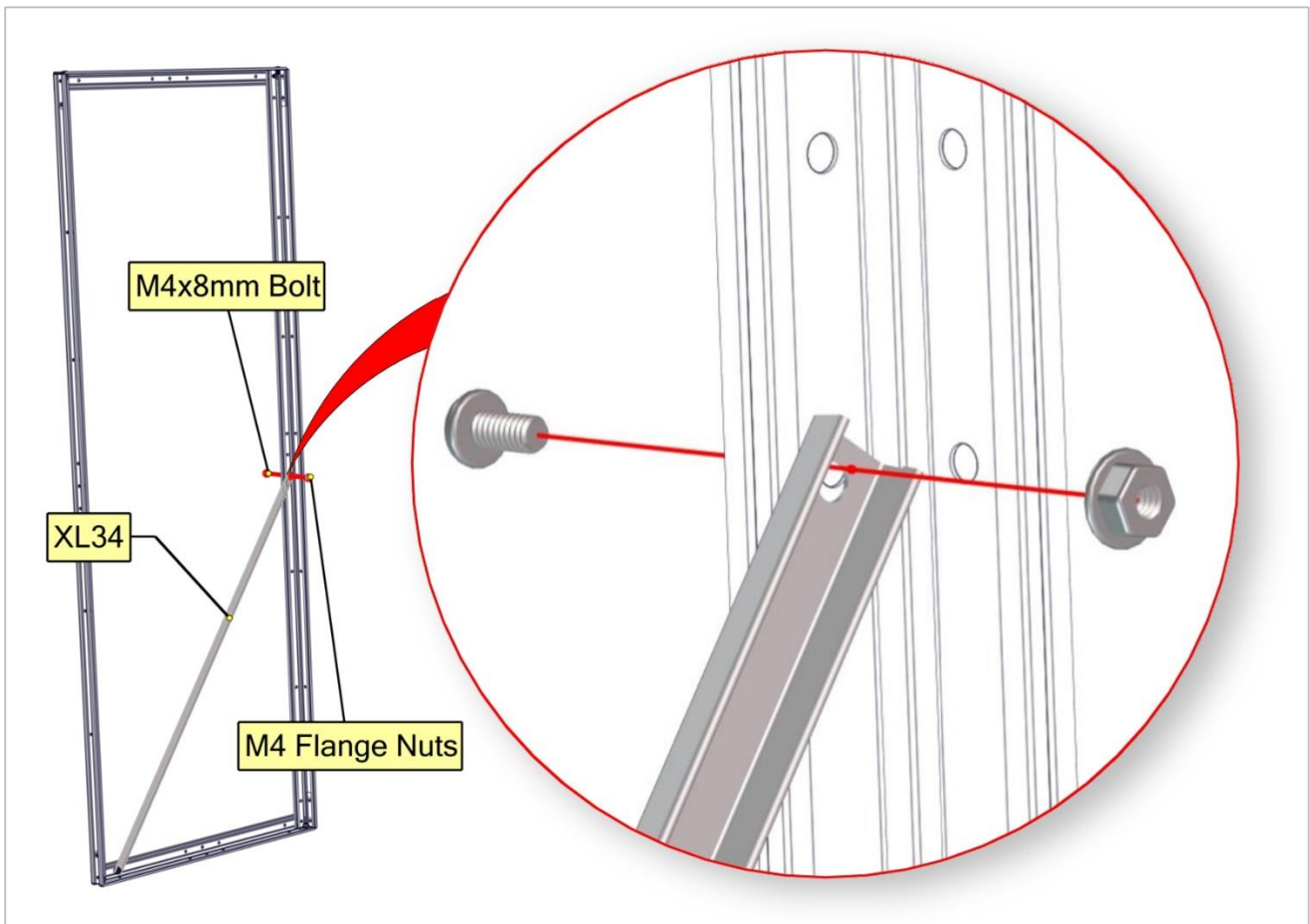
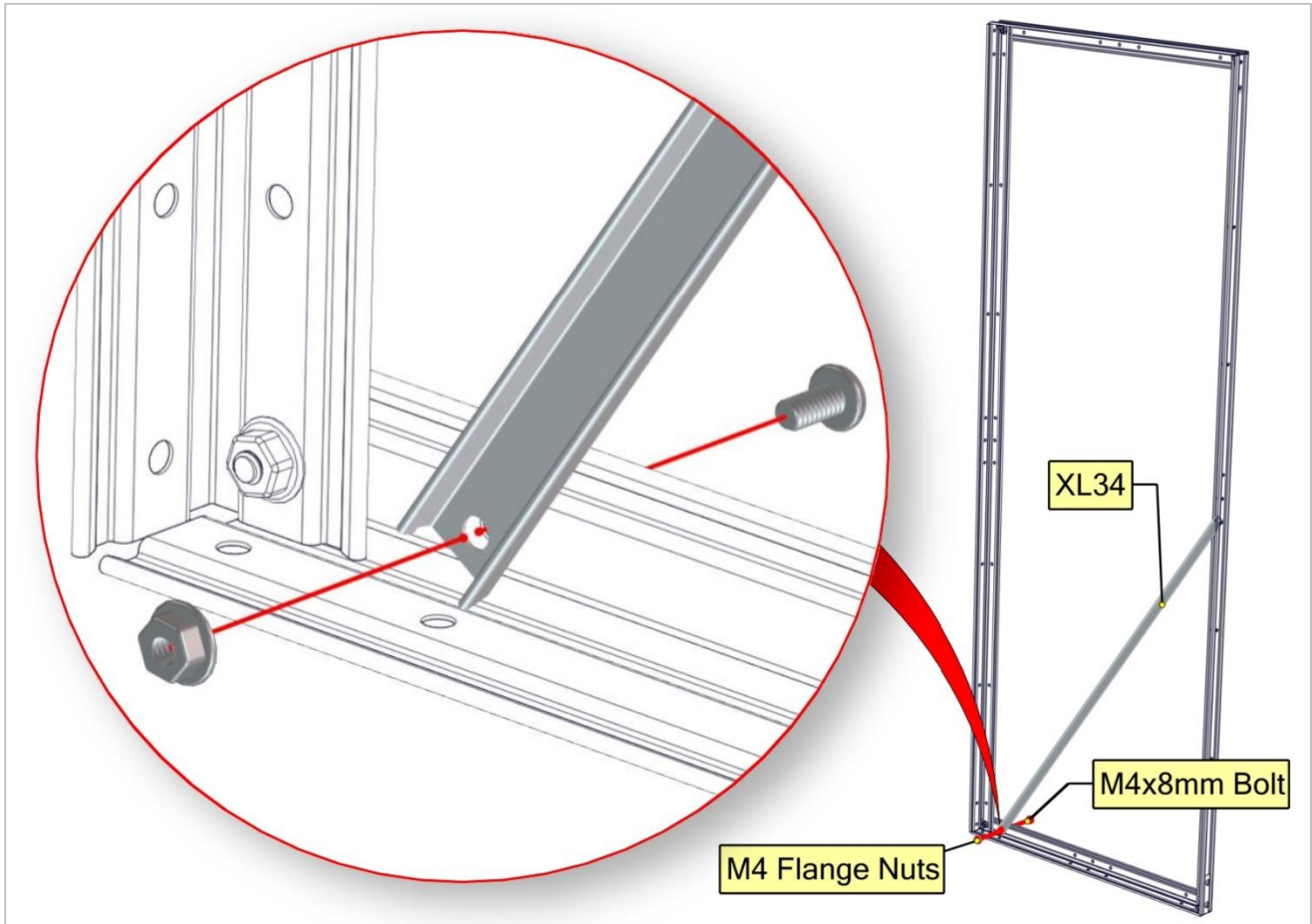

Joining End Assemblies

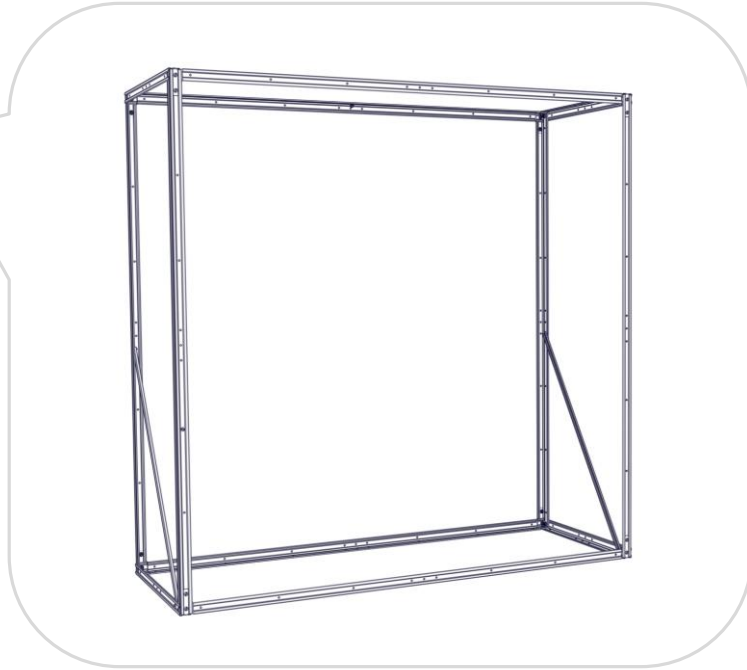

Step 3 - Bolt together the two end assemblies using horizontal sections

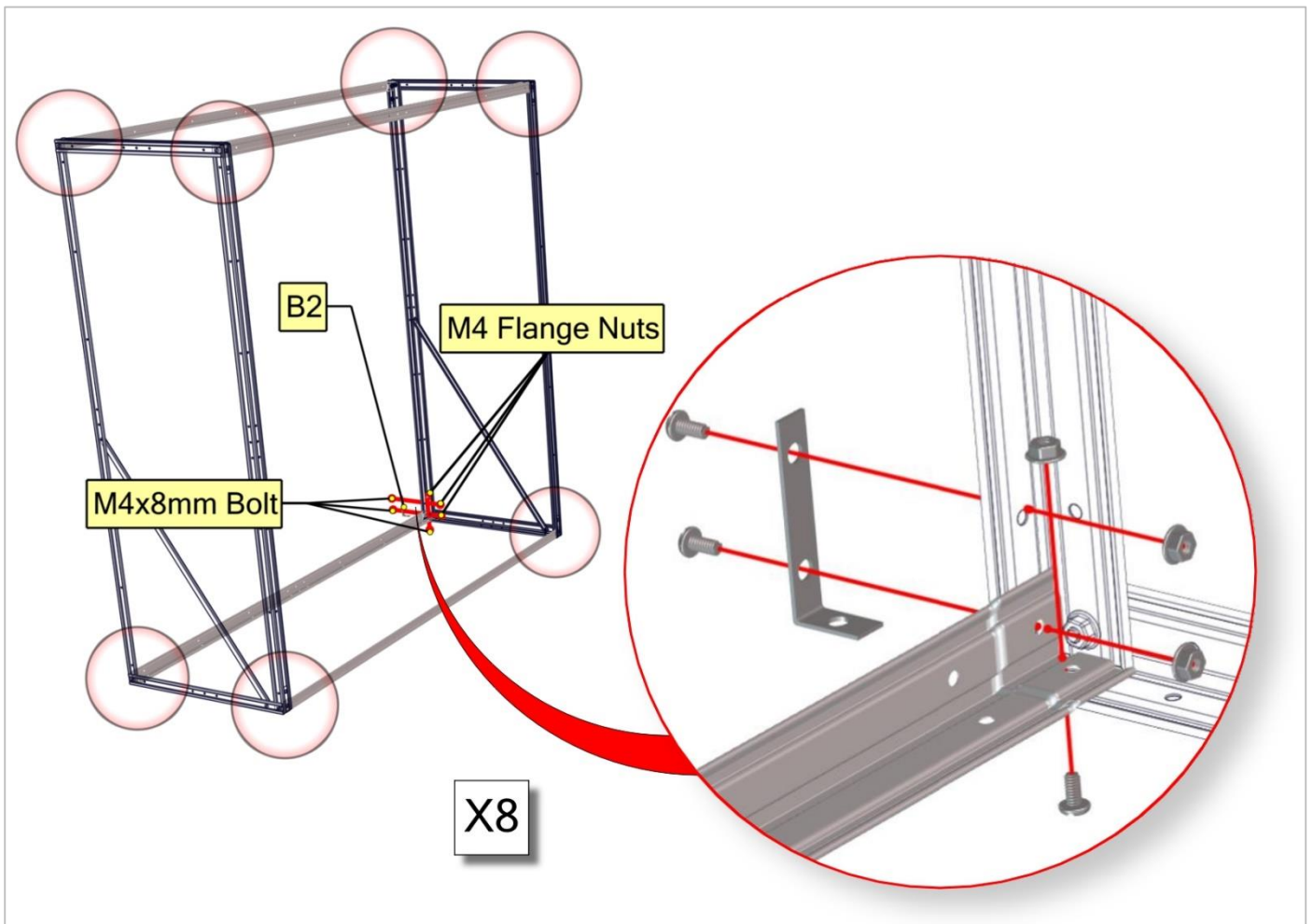

Adding Middle and Lower Racking



Step 4 - Bolt in horizontal racking sections

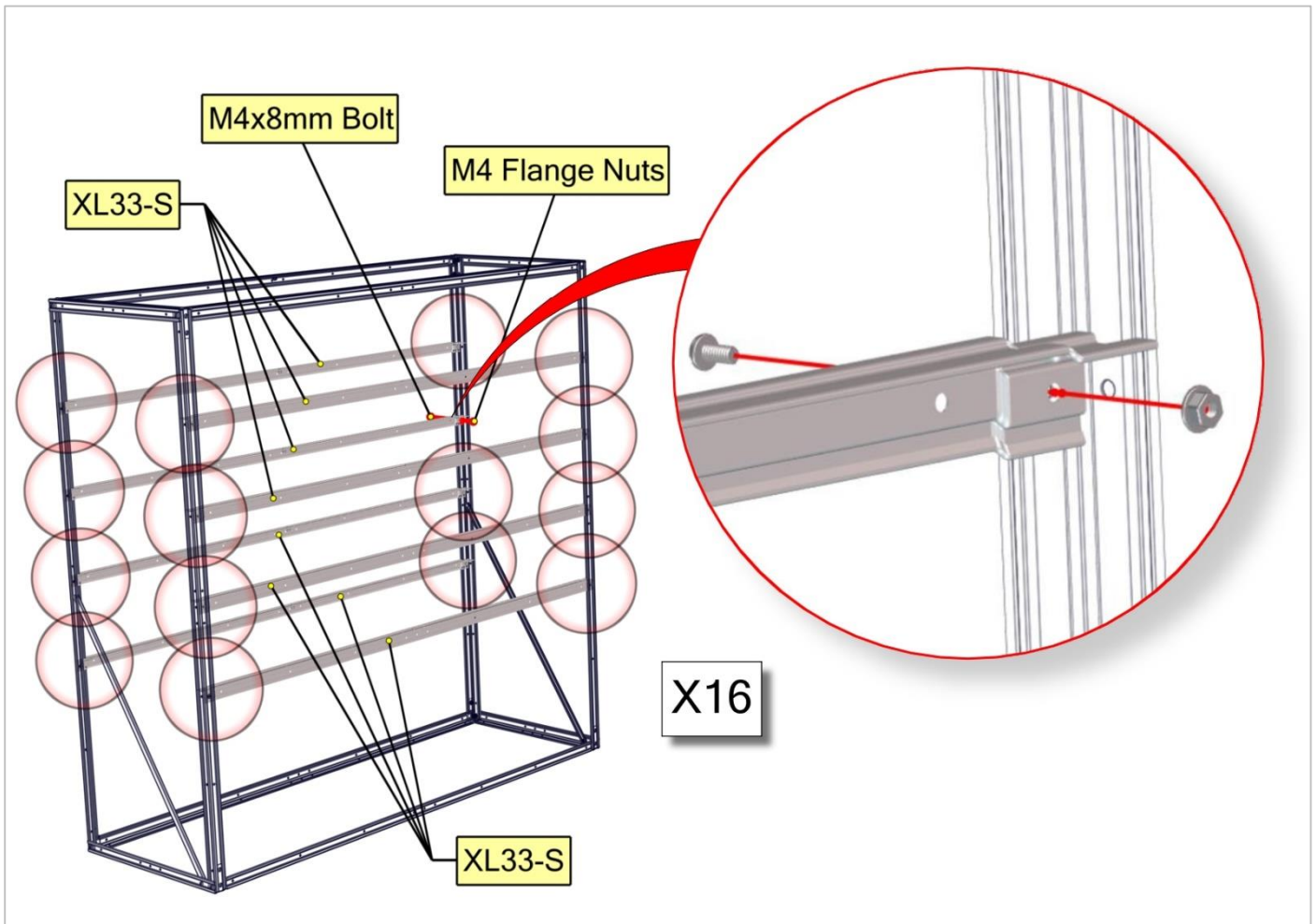

Adding Middle and Lower Racking



Step 5 - Bolt in Racking Braces

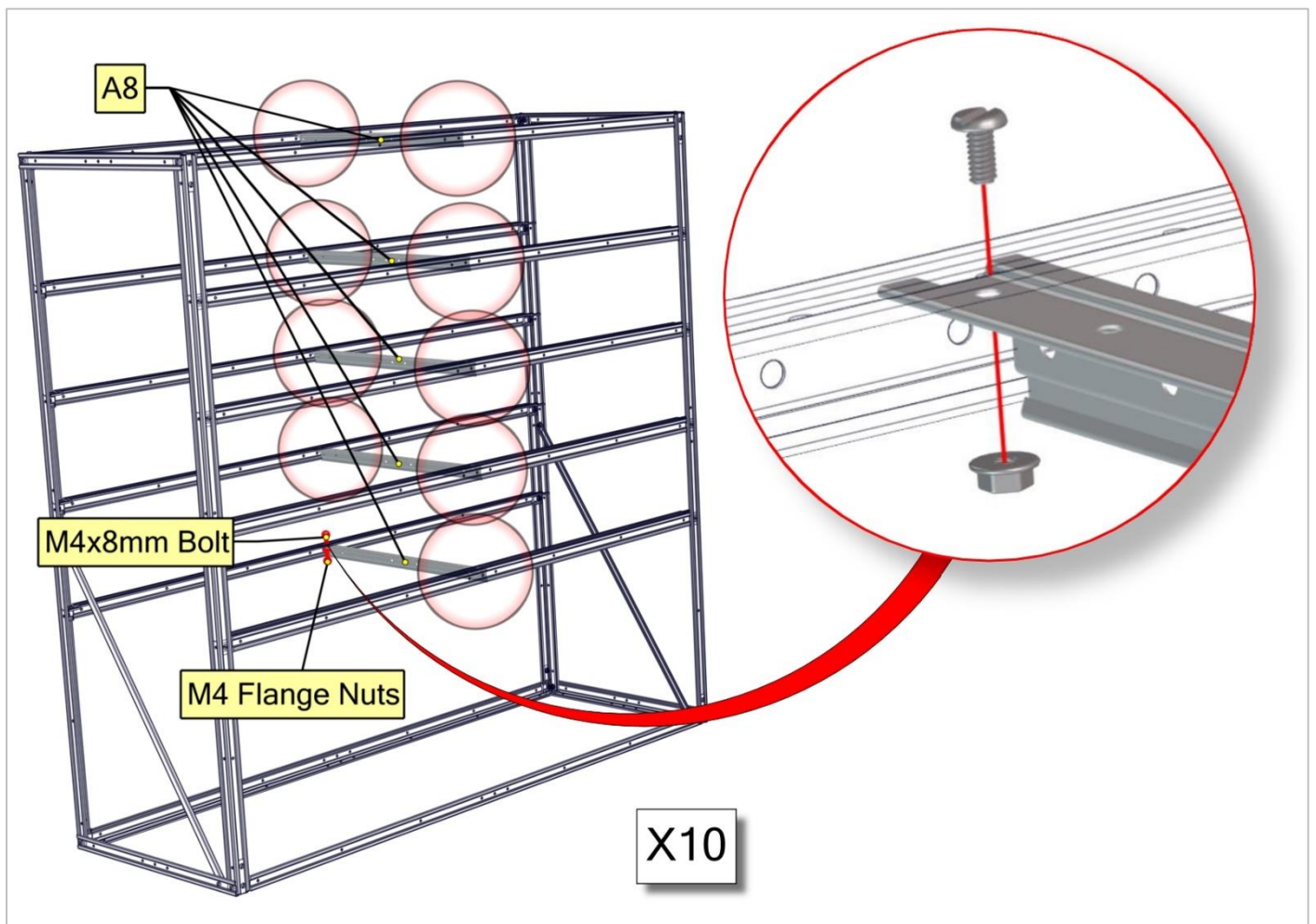



(BWC Greenhouses Ltd trading as)

Norfolk Greenhouses

Chiswick Avenue
Mildenhall
Suffolk
IP28 7AZ

Tel: **020 3011 2040**

Email: info@norfolk-greenhouses.co.uk

Web: www.norfolk-greenhouses.co.uk