

Supplied By

**CRAIVE HANDLING**

**electric wire rope hoist**

**DRH**

**series**



 **donati**

# ELECTRIC WIRE ROPE HOIST

It guarantees maximum safety in hoisting up to 40.000 kg. The competence and experience in design and production, the quality of components used, the high technology employed in the production of mechanical parts, in the finish and in surface treatments as well as the certified quality system UNI EN ISO 9001:2000 which regulates all the company's activity, allow DONATI SOLLEVAMENTI to offer a product in line with the most modern international regularity standards.

The DRH electric rope hoist ensures use in a wide range of situations, reliability over time and safety in all operative phases.

The special hydro-repellent finish, obtained by an electrostatic process, guarantees long life and consistency in performance even in particularly hostile environments.

The company offers a 3-year guarantee starting from the date of delivery, all at a reasonable price.

DONATI

SOLLEVAMENTI S.r.L.

INTRODUCES A NEW AND  
EVEN MORE EVOLVED RANGE  
OF DRH ELECTRIC WIRE  
ROPE HOISTS.

SAFE, RELIABLE, COMPACT  
AND ECONOMICAL.

THEY REPRESENT THE MOST  
MODERN AND ECONOMICAL  
MEANS OF LIFTING LOADS  
UP TO 40.000 kg,  
IN ABSOLUTE SAFETY.

re rope hoists  
wi  
ic electr



and tro  
lleys

pow er and safe  
ty



at your d  
is  
pos

safety atd

power a  
n

yo

u  
rd

isp

os  
al

## ELECTRICWIRE ROPE HOISTS and TROLLEYS

The hoist combined with a trolley which runs on one or two beams also allows horizontal movements. All lifting (raise and lower) and traverse (right and left) movements are activated

electrically and can be activated via a fixed pendant, a radio-control system or infra red.

The range of the DRH series electric wire rope hoists has been developed in:

- 4 basic sizes, DRH 1-2-3-4, to lift from 800 to 40.000 kg, including 1020 standard executions, in the FEM service group (ISO) 1Am (M4) – 2m (M5) – 3m (M6).
- with one lifting speed made with a 4 pole motor:
  - 4 or 6 m/min. for 4 rope falls hoists
  - 8 or 12 m/min. for 2 rope falls hoists
- with two speeds made with a 4/12 pole motor:
  - 4/1,3 or 6/2 m/min. for 4 rope falls hoists
  - 8/2,6 or 12/4 m/min. for 2 rope falls hoists
- with three speeds made with a 4/12 pole motor, the micro speed is made by frequency control device
- 5 standard versions with a: short (C), normal (N), long (L) or extra long (X1 and X2) drum lengths, for hook runs from 4 to 58 m.

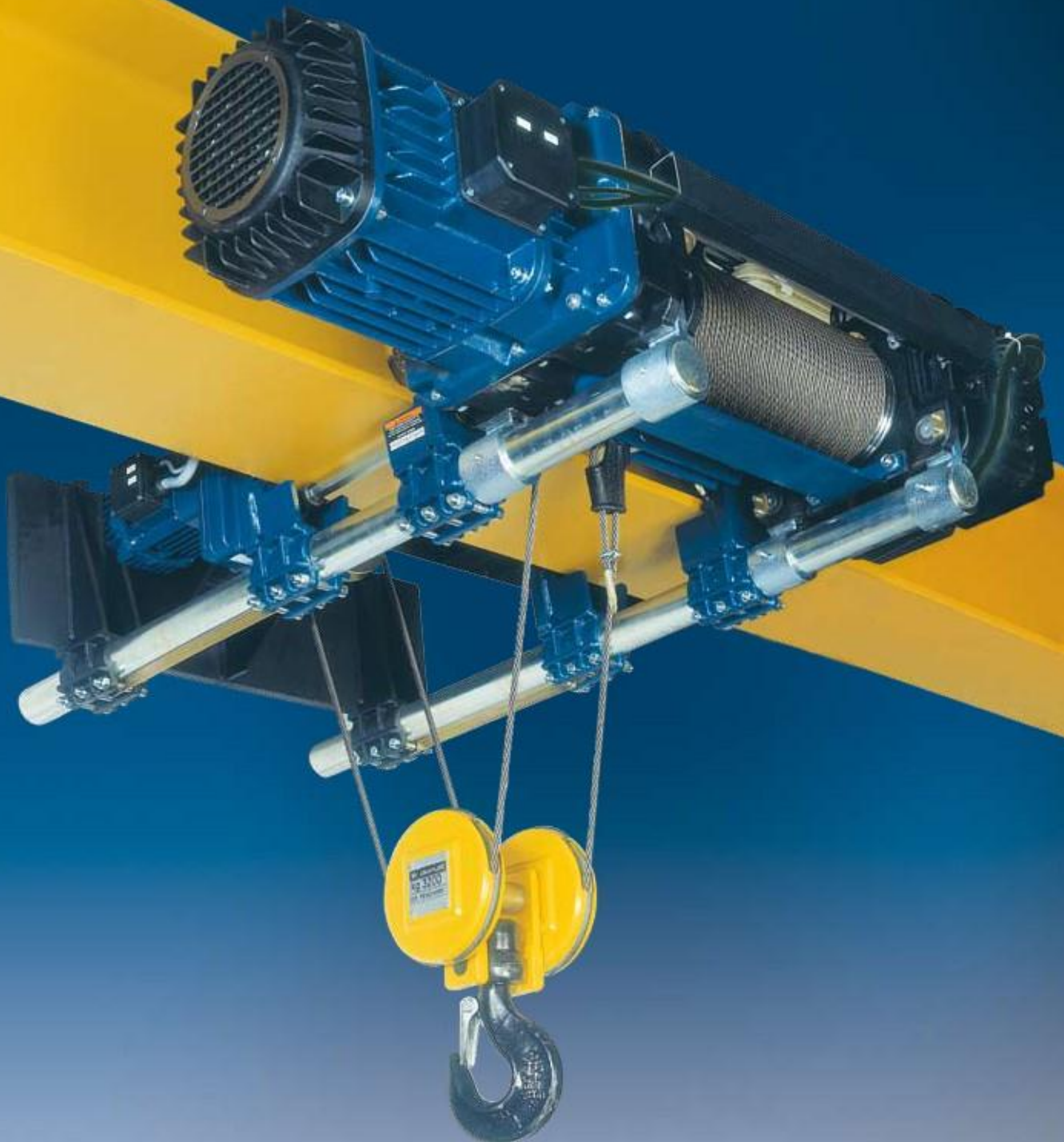

# ELECTRIC WIRE ROPE

# HOIST

range of  
the r  
th  
DRH  
series

## Fixed configuration

This is the universal, basic configuration, with fixing eye-bolts that allow the DRH hoist fixing on a frame as a double girder trolley or in a suspended execution.

## Configuration with monorail trolleys type DST/N/S

The DRH hoist is supplied in suspended execution with the normal headroom trolley or with the articulated one in case the unit has to run on curves. The trolley is electrically operated.

## Configuration with monorail trolley type DST/R

In this configuration the DRH hoist is supplied in low headroom version for a maximum height of lift.

## Configuration with double girder trolley type DRT

The DRH hoist can be fitted on the top of the double girder trolley frame or suspended. It can be supplied also in transversal execution. The trolley is electrically operated and run on two rails this configuration allows to obtain the maximum hookpath.

The DRH series electric wire rope hoists and relative electric trolleys are made with modular components. This allows multiple normalised or special executions to be made quickly, economically but most importantly, safely. To guarantee maximum use of the hook run and minimum overall dimensions of the hoist body, the base components (motor, reducer and rope drum) are assembled in a coaxial line, by way of high strength bolted connections. Every connection can be inspected and has self-locking safety nuts. This type of construction, equally as important for the efficiency as for the safety of the hoist, is possible thanks to the extremely compact gear motor unit.

The rope drum on the side opposite the gear motor, can be connected to a cycle counter, selectors, limit switches, encoders, safety brakes etc.

Furthermore, being perfectly symmetrical in the special execution with drum right and left grooved, allows two gear motors to be installed thereby doubling the lifting speed but keeping the same capacity with a true vertical lift. This is a particularly suitable option for executions with large hook runs.

The assembly process uses the most advanced technology and highly industrialised production processes to produce, by economies of scale, totally reliable and technically innovative machines.



## Enclosure and insulation of electrical components

- Hoist and trolley motors: IP55 protection – Class “F” insulation.
- IP23 hoist-motor brake.
- Limit switch: IP65 minimum protection. Maximum insulation voltage 500 V
- Cables: CEI 20/22 II Maximum insulation voltage 450/750 V
- DRH electric rope hoists are designed to be supplied with alternate electric current with three-phase voltage: 400 V – 50 Hz, in accordance with IEC 38-1
- Voltage and frequency different from standard are available on request.

## Working conditions

- Working temperature: minimum –10°C; maximum +40°C
- Maximum relative humidity: 80%
- Maximum altitude 1000 m above sea level
- The hoist must be installed in a well aired environment free of corrosive vapours (acidic vapours, saline mist, etc.)

## Noise levels

- The noise level emitted by a fully loaded hoist is always less than 85 dB (A). However, the transmission of noise through metal structures and the reflection due a machine being located near a wall, are not included in the indicated value.

# THE HOIST In DETAIL

**1. Electric motor for lifting**  
Asynchronous three-phase, self-braking with tapered motor. Minimum protection IP 55 – Class F insulation. It has thermal probes for protection against overloading.

**2. Hoist's brake**  
The brake's lining is asbestos free. The brake block, which has a fan that guarantees the cooling of the brake itself and of the motor, moves axially with the motor shaft and the braking function is activated automatically if the energy supply fails.

(RES. 1.2.6 – 4.1.1.6 c – Attachment I Machine Directive).

**3. Joint**  
It's the connection between the self-braking motor and the reducer, allowing perfect axial sliding of the motor shaft.

**4. Reducer (gearbox)**  
Coaxial, with three stages of reduction, with cylindrical gears made of thermally treated, highly resistant steel, helicoidal teeth. Dimensioned and made to withstand the phenomena of stress and wear for life in relation to the normal FEM service group.

(RES. 4.1.2.3 – Attachment I Machine Directive).

The whole machine is mounted on spherical bearings lubricated for life in an oil bath.

**5. Drum**  
The drum in steel casing, is mechanically grooved, and supported by the flange of the reducer and by the equipment side flange, with hubs with rotating broached holes on permanently lubricated bearings. The rope drum is made in line with the ISO standard 4308-1 and UNI 9466 and the FEM rules 9.661/86 and the ratio of the diametral pitch of the same and the diameter of the wound rope is never < 20 (FEM 3m). The rope-drum support flanges have steel cylindrical pins in order to secure the components which suspend the hoist or which support it when set on machined seatings support the anchorage crossheads and the return pulley. The connection between the two flanges is made with bolted staybolts. A protective roof, made of shock-resistant transparent plastic, is fixed above the hoist.

**6. Rope guide**  
It has a threaded ring made of spheroidal graphite cast iron and allows the rope to be wound well onto the drum.

(RES. 4.1.2.4. – Attachment I Machine Directive).

The system automatically registers any play or wear which may occur. The rope guide includes sliding backlash arms made of brass, which, acting on the staybolts of the hoist, they function as raise and lower limit switches.

**7. Raise and lower limit switch**  
It is a safety component which limits, in an emergency, the run of the hook in raise and lower.

(RES. 4.1.2.6. a – Attachment I Machine Directive)

There are two micro-switches which work according to the positive slow opening principle and act on the auxiliary circuit of the control device of the hoist's motor.

**8. Pulley assembly**  
Utilised in versions with more than 2 rope falls, and supported by two pivots which allow it to be orientated depending on the vertical axis of the rope. The return pulley is made of carbon steel. The rim has been grooved mechanically and the sheave rotates on bearings which are permanently lubricated.

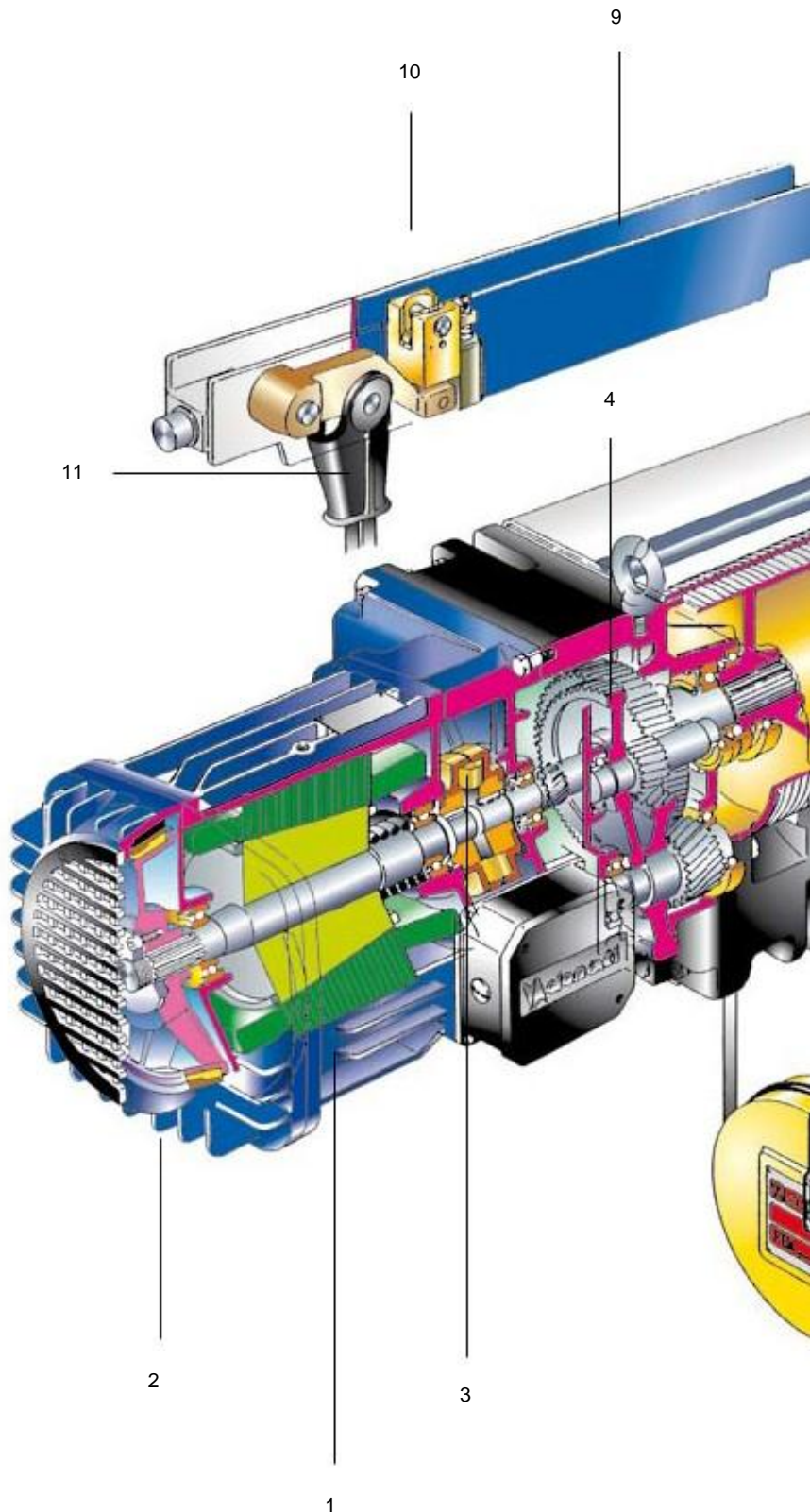

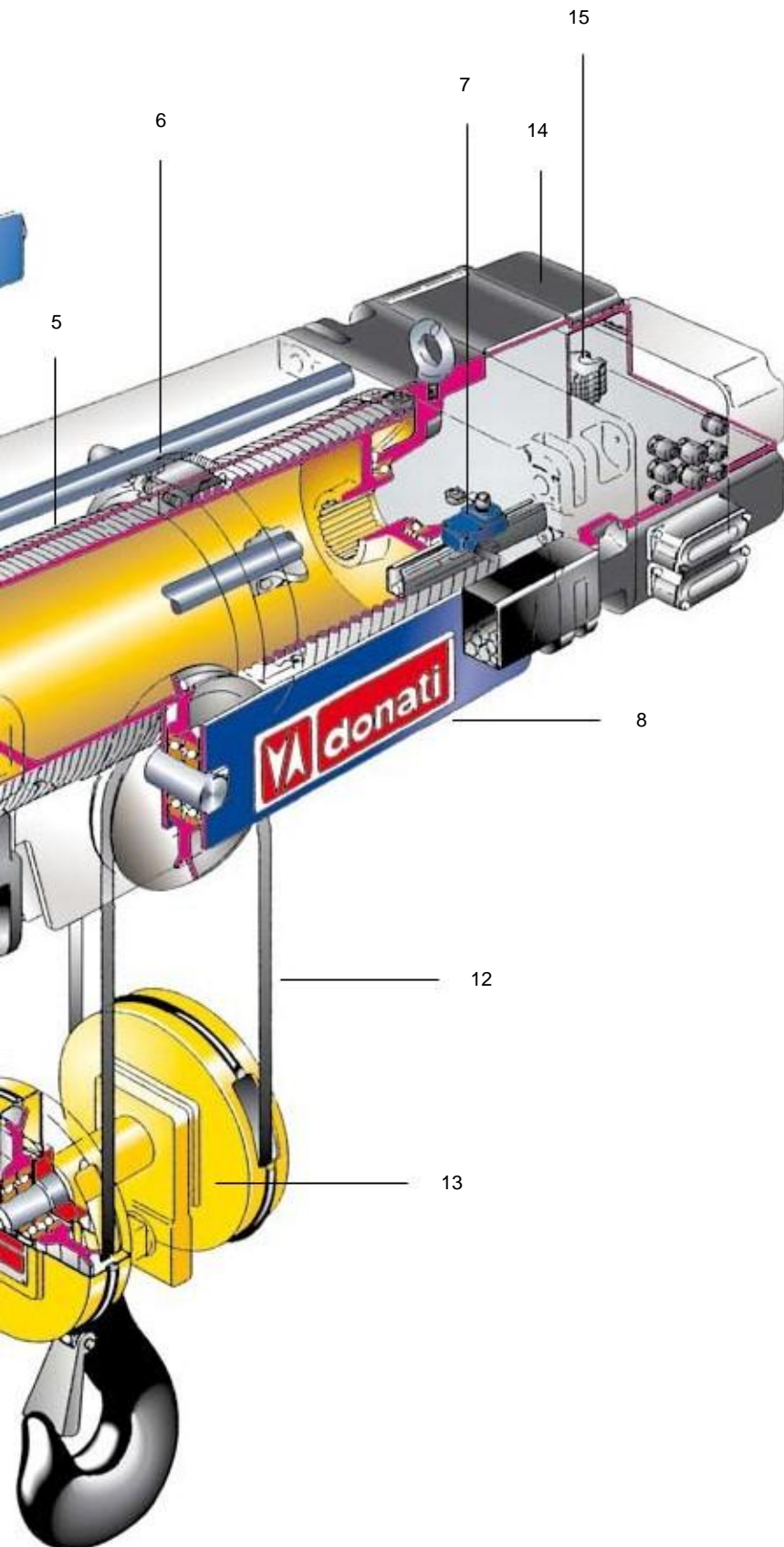

#### 9. Anchorage crosshead

Utilised in standard versions, and supported by two pivots which allow it to be orientated depending on the vertical axis of the rope. The overload device is located between the plates of the transverse.

#### 10. Overload device

All the DRH series electric rope hoists have an overload device with a threshold level micro-switch.

[RES. 4.2.1.4. – Attachment I Machine Directive].

The overload device constantly measures and checks the values of the load and the dynamic and inertial effects due to its movement. Whenever the set levels is exceeded the micro-switch of the device starts by opening the control circuit of the lifting-controls device.

#### 11. Wedge anchorage

The anchorage is made of spheroidal graphite cast iron. The minimum coefficient for use conforms to the FEM rule 9.661/86. The rope is secured with a wedge which stops it from unwinding.

#### 12. Rope

Made of flexible steel, highly resistant to strain and wear. The minimum coefficient of use has been chosen to conform to the ISO standard 4308-1. Non-twist ropes are used on DRH hoist with 2 falls and long (L) and extra long, 1st size (X1) drums, and on 2 and 4 fall hoists with extra long, 2nd size (X2) drums.

#### 13. Hook block and hook

The return pulley is made of carbon steel and the rim has been grooved mechanically. It rotates on bearings which are permanently lubricated. The load hook is made of highly resistant drop-forged steel and is mounted on an swinging cross beam. It rotates on a thrust bearing and has a safety device to avoid unhooking.

[RES. 4.1.2.6 - Allegato I Direttiva Macchine].

#### 14. Frame for electrical connections

Supplied on request. It has cable intake and allows the wiring of all the connections of the electrical equipment of the hoist and electric travel trolley, if present. The compartment for the electrical connections and/or any other low voltage control equipment, is closed with a shock resistant thermoplastic cover, IP 55 enclosure.

#### 15. Low voltage controls

When the hoist is supplied complete with electric controls, the raise and lower and /or right and left functions of the trolley, are activated by electrical equipment which includes:

The transformer for control circuits.

- The main contactor and the contactors/reversing contactor for controlling the motors.
- The fuses for protection of the motors and transformer.
- The terminal board for the connections of auxiliary and power circuits.

The components are mounted on a hinged panel and fixed in a compartment located on the side opposite the motor. The controls are activated by a push-buttons-panel, supplied in AC at low voltage, 48V. The push-buttons-panel is ergonomically shaped, watertight and made of self-extinguishing, shock resistant, thermoplastic material. Its level of protection is IP 65.

The emergency stop [RES. 1.2.4 – Attachment I Machine Directive], is activated by voluntarily pushing the mushroom shaped button, which starts the control circuit [RES. 1.2.3 – Attachment I Machine Directive].

The push-buttons-panel is connected to the electrical equipment by a multipolar electrical cable with break-resistant metallic cores.

sd as emblin

an  
design

g pr  
OC  
ES  
S

## TROLLEYs

Monorail electric trolley,  
types DST/N –S – R –

• Normal – Articulated – Reduced •

They are usually composed of an idler wheel and a drive wheel assembly, both have two wheels made of machined pressed steel, and mounted on spherical bearings which are permanently lubricated. The wheels of the drive wheel assembly are opposing and have a crown gear wheel and are connected, in the normal (N) and reduced (R) versions, by a transmission bar. The articulated version (S) has a double motoreducer, both of which directly give the wheels the movement. The steel supporting plates have anti derailment and anti drop device [RES. 4.1.2.2 – Attachment I Machine Directive] and have rubber buffers. Traveling is assured by one or two self-braking motors. They have tapered motor, progressive start up and braking, one or two speeds and one or two offset geared motors with gears with helicoidal teeth which are permanently lubricated in an oil bath.

Electric trolley

Normal monorail, standard headroom,  
type DST/N

In the normal version the trolley has supporting bars with circular cross-sections which support the hoist by a hinge-pin type suspension. The drive and idler plates can be adjusted along the bars in relation to the width of the running beam and are complete with brackets which have bolted joints. Both assemblies, drive and idler, are connected to each other with strengthening plates.

Electric trolley, monorail, reduced  
headroom, type DST/R

In the low headroom version the trolley has supporting bars with circular cross-sections which support the hoist in a set-down position. The drive and idler plates are sliding and can be adjusted along the bars, in relation to the width of the running beam, with brackets which have bolted joints. The trolley has a counterbalance on the supporting bar with a circular cross-section in order to balance the eccentric weight of the hoist.

Electric trolley, monorail, articulated,  
type DST/S

In the articulated version the trolley has supporting bars with circular cross-sections and brackets with hinged joints which support the hoist. The drive and idler plates are sliding and can be adjusted along the bars, in relation to the width of the running beam, with brackets which have bolted joints. Both drive wheel assemblies are opposing on the same bar and are independent from the two idler wheel assemblies.







**monorail  
trolley**

**Electric trolley, double girder, type DRT**

The wheels, two of which are driven and two are idler, are supported by a steel crab frame. The wheels, pressed from carbon steel, rotate on permanently lubricated spherical bearings. The double girder trolley has devices to avoid derailment and anti drop [RES. 4.1.2.2 – Attachment I Machine Directive] and rubber buffers.

Activation of traverse is assured by a self-braking motor with tapered motor, progressive start-up and braking, one or two speeds and one offset reducer with gears with helicoidal teeth which are permanently lubricated in an oil bath, which confer the movement to the drive wheels by a transmission bar.

The hoist can be fitted on the top of the trolley or can be suspended and transversal.



**Traverse limit switches**

On request all trolleys can be supplied complete with the limit switches

[RES. 4.1.2.6 a – Attachment I Machine Directive].

**Towing arm**

A towing arm is available on request for all types of trolleys, adjustable in all directions, to connect the trolley/hoist to the electricity supply and to avoid breakage of the conductors.

**Oscillating brackets for hoists mounted on a DST/N trolley.**

Available on request to allow the hoist to oscillate with respect to the vertical axis of the running beam.



**double  
girder  
trolley**

## QUALITY PRODUCTS OF a LEADER COMPANY

Donati range of products meets the demands of hoisting equipment for manufacturing industry applications, offering an incomparable relation between quality and price coupled with professional design.

The electric chain hoist DMK series with capacities up to 4000 Kg, the hand-push and powered slewing jib cranes, the electric wire rope hoist DRH series with capacities up to 40000 Kg, the suspended DSC channel profile systems and the wheel drive unit DGP, represent solutions for handling problems safely and economically.

Special versions for all products and also versions with CSA/US approval are available on request.

The constant care of DONATI SOLLEVAMENTI S.r.l. over the customer satisfaction is directed to establish a long-term relation, based on the mutual respect and trust, thanks to the flexibility and promptitude of the organization and to the direct and personal contact.

The after-sales service is organized in order to give prompt answers and solutions about spares-parts, service and warranties procedures.

Since 1930 DONATI SOLLEVAMENTI S.r.l. has become more and more successful in international markets for lifting equipment,

due to our flexible, technological and design innovation.

The experience of many years of qualified modern international presence in the market and the precise will to face the issues about safety and conformity

to the rules without any compromises are a guarantee of safety and reliability.

The constant quality and reliability of all our products and services are granted from the certification of our internal quality insurance system, regulated since 1993,

Donati organization, starting from the control of the materials and of the manufacturing process till the finished products.



DONATI SOLLEVAMENTI S.r.l.

offer a range of products

in line with the most

modern international presence in the market and the precise will to

regularity standards.





and assembling  
the design process  
**CERTIFICATES AND GUARANTEES**



The on going and careful attention to quality by Donati Sollevamenti S.r.l seen, not only through our careful design, responsible choices and constant checks of materials, of all phases of production and of the finished product, but it also involves the whole organisation, through the quality control system which, since 1993, controls and checks the life of the whole company.

The integrity in the design and production of all Donati products would not be complete without the careful consideration of the international regulations referred to which give a guarantee of safety for the Client and user and acts as a passport for internationalisation and diffusion of our products throughout the world. In this light we recommend reading the recent CSA approval with extension ANSI/UL of the DRH rope hoists and relative accessories and translation trolleys made in special execution for the north American market.

The DRH series electric rope hoists and relative trolleys are designed and produced taking into consideration the "Essential Requirements" of Safety in Attachment I of the Community Directive 98/37/CE ex 89/392 CEE and subsequent amendments 91/368/CEE, 93/44/CEE and 93/68/CEE, denominated Machine Directive. Furthermore, the DRH series hoists and relative trolleys conform to the following Directives: Low Voltage Directive (DBT) 2006/95/CE.

Electromagnetic Compatibility Directive (EMC) 2004/108/CE.

**Regulatory framework**

The following are the main technical rules and regulations which were taken into consideration during the design and assembling of the DRH series electric rope hoists:

- EN 12100 parts: 1a - 2a "Safety of the machinery".
- EN 60204 - 32: "Safety of the electrical equipment of lifting machines".
- EN 60439 - 1: "Low voltage controls equipment".
- EN 60529: "IP enclosure".

- ISO 4301 - 1: "Classification of lifting equipment".
- ISO 4308 - 1: "Choice of ropes".
- UNI 7670: "Calculation of the mechanisms of the lifting equipments".
- UNI 9466: "Calculation of the drums".
- DIN 15401: "Choice of the lifting hooks".
- FEM 1,001/98: "Calculation of the lifting equipments".
- FEM 9,511/86: "Classification of the mechanisms".

- FEM 9,661/86: "Choice of the drums, ropes and pulleys".
- FEM 9,683/95: "Choice of the lifting and traverse motors".
- FEM 9,755/93: "Periods of safe work".
- FEM 9,941/95: "Control symbols".

## Criteria and condition of use

- Correctly determine the operating limits of the hoist in order to ensure the correct functioning and the complete correspondence to the operating systems of the work for which it is intended.
- The FEM 9.511 rule allows the classification of hoists according to the conditions of use.
- The necessary parameters to determine the limits of use for electric wire rope hoists are the following:

- 1) Actual lifting capacity
- 2) Stress level
- 3) Average duration of daily use

### 1) Actual lifting capacity

- This is determined by the heaviest load to be lifted.

<b>!</b>	The nominal lifting capacity of the hoist must be $\leq$ the actual lifting capacity	Lifting capacity = kg
----------	--	-----------------------

### 2) Stress level

- The stress level is determined considering the actual entity of the loads lifted and it is ascribable to one of the four spectrums of load shown below which determine the type of service.

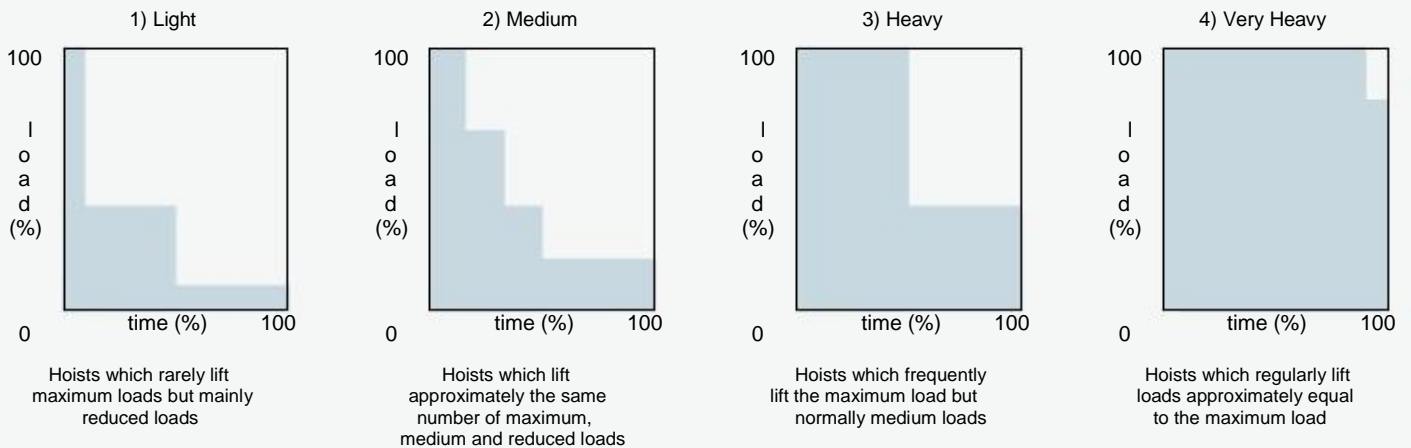

### 3) Average duration of daily use - $T_m = \text{Hours}$



- For lifting operations the average duration of use is calculated in the following way:

$$T_m \text{ (hours)} = \frac{A H C_e \times C/h \times T_i}{30 \times V}$$

<p>Actual hook run <math>AHR = m</math></p> <p><math>C_e = m</math></p> <p>It is the average of the actual runs of the load</p>	<p>Operative cycles <math>C/h = N^\circ \text{ cycles per hour}</math></p> <p><math>C/h = N^\circ \text{ cycles for hour}</math></p> <p>It is the number of complete ascents and descents carried out in an hour</p>	<p>Running time <math>R_t = \text{hours}</math></p> <p><math>T_i = \text{hours}</math></p> <p>Hoist running time in a whole day</p>	<p>Lifting speed <math>S = m/\text{min.}</math></p> <p><math>V = m/\text{min.}</math></p> <p>It is the distance covered by the load in a minute</p>
---	--	---	---

• For travel operations the average duration of use is determined in the following way:

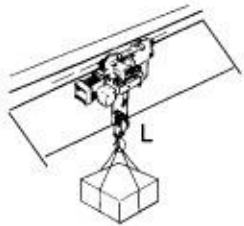
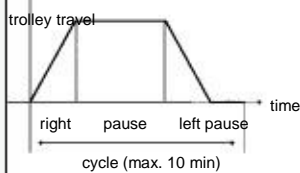
$$T_m \text{ (hours)} = \frac{P_m \times C/h \times T_i}{30 \times V}$$

<p>Actual average run AAR (m) = L/2</p>  <p>P<sub>m</sub> (m) = L/2</p> <p>It is the average of the length L of the trolley running beam</p>	<p>Operative cycles C/h = N° cycles for hour</p>  <p>C/h = N° cycles for hour</p> <p>It is the number of complete runs (right/left) carried out in an hour</p>	<p>Running time Rt = ore</p>  <p>T<sub>i</sub> = hours</p> <p>It is the running time of the trolley in a day</p>	<p>Travel speed S = m/min.</p>  <p>V = m/min.</p> <p>It is the distance covered by the trolley in a minute of continuous running</p>
---	---	--	---

Having determined the stress level and the average duration of daily use for lifting and/or travelling, using the following table the identification group of the relative mechanisms are classified and then, according to the lifting capacity, the type of hoist is determined.

Level of stress			Average daily running time - T <sub>m</sub> = Hours						
1) Light Load			δ 2	δ 4	δ 8	δ 16	> 16	-	
2) Medium Load			δ 1	δ 2	δ 4	δ 8	δ 16	> 16	
3) Heavy Load			δ 0,5	δ 1	δ 2	δ 4	δ 8	δ 16	
4) Very Heavy Load			δ 0,25	δ 0,5	δ 1	δ 2	δ 4	δ 8	
Service group of the lifting mechanisms and translation		ISO 4301/88 FEM 9.511/86	M3 1Bm		M4	M5	M6	M7	M8
Intermittent use according to FEM standard	Ratio of intermittence (RI%)		25	30	40	50	60	60	5m
	N° Start-ups per hour (A/h)		150	180	240	300	360	360	
	N° Cycles per hour (C/h)		25	30	40	50	60	60	
	Ratio of intermittence (RI%)		20	25	30	40	50	60	
	N° Start-ups per hour (A/h)		120	150	180	240	300	> 360	
	N° Cycles per hour (C/h)		20	25	30	40	50	> 60	
Two-speed double-polarity motors	N° Start-ups per hour (A/h)	Main speed	1/3 (33.3 % of total N° of start-ups per hour)						
		Low speed	2/3 (66.7 % of total N° of start-ups per hour)						
	Daily running time (T <sub>m</sub> )	Main speed	2/3 (66.7 % of the average daily running time)						
		Low speed	1/3 (33.3 % of the average daily running time)						
Temporary use	Running time at main speed (min)		15	15	30	30	60	> 60	
	Running time at low speed (min.)		2,5	3	3,5	4	5	6	
	Maximum N° of start-ups per hour (A/h)		10	10	10	10	10	10	

Example:

Calculation of the average daily running time (T<sub>m</sub>) based on the following factors:

Capacity = 6300 kg; Level of stress = Medium load 2); Actual hook run (AHR) = 3 m; N° Hourly Cycles (C/h) = 10; Daily running time (Rt) = 8 h; Lifting speed (S) = 4 m/min. Performed with a hoist with 4 rope falls.

$$T_m \text{ (hours)} = \frac{C_e \times C/h \times T_i}{30 \times V \times 30 \times 4} = 3 \times 10 \times 8 = 2 \text{ h}$$

In the table in section 2.2.7, in relation to the capacity (6300 kg), at a medium level of stress (2) and at an average daily running time (T<sub>m</sub> = 2 h) it is possible to determine the rope hoist, with 4/1 falls of rope, which is:

FEM service group 1Am - Type DRH 24L1•M



- The designation of the group of utilization of the wire rope hoist is shown on the label plate on the hoist (see paragraph 3.5.3 - List of labelling plates)
- DONATI SOLLEVAMENTI S.r.l. guarantees the safe and lasting utilization only if the DRH electric wire rope hoist is used according to the corresponding parameters for the group of utilization foreseen.

# Identification of hoists and related trolleys

Configuration of ropes (single-grooved drum)

Capacity kg	Letter	reducer
800 800	L V	capacity D
1000 1000	L V	E E
1250 1250	L V	F F
1600 1600	L V	G G
2000 2000	L V	H H
2500 2500	L V	I I
3200 3200	L V	J J
4000 4000	L V	K K
5000 5000	L V	L L
6300 6300	L V	M M
8000 8000	L V	N N
10000 10000	L V	O O
12500 12500	L V	P P
16000	L	Q
20000	L	R

Size1 DRH

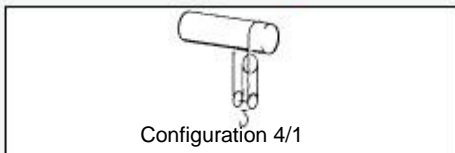

DRH	Type FEM (M4)	in group	relation (ISO)	to
1Am	(M5)			2m
	(M6)	=>	14L3•E 14V3•E	3m
		=>	14L3•F 14V3•F	
		=>	14L3•G 14V3•G	
		=>	14L2•H 14V2•H	
		=>	14L3•I 14V3•I	
		=>	14L1•J 14V1•J	
		=>	14L1•K 14V1•K	
		=>	14L1•L 14V1•L	
		=>	14L1•M 14V1•M	
		=>	14L1•N 14V1•N	
		=>	14L1•O 14V1•O	
		=>	14L1•P 14V1•P	
		=>	14L1•Q 14V1•Q	
		=>	14L1•R 14V1•R	

Size2 DRH

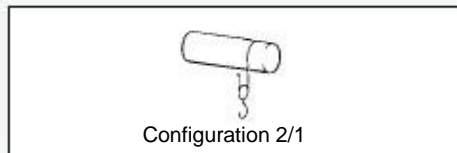

DRH	Type FEM (M4)	in group	relation (ISO)	to
1Am	(M5)	=>	12L3•D 12V3•D	2m
	(M6)	=>	12L2•E 12V2•E	3m
		=>	12L1•F 12V1•F	
		=>	12L1•G 12V1•G	
		=>	12L1•H 12V1•H	
		=>	12L1•I 12V1•I	
		=>	12L1•J 12V1•J	
		=>	12L1•K 12V1•K	
		=>	12L1•L 12V1•L	
		=>	12L1•M 12V1•M	
		=>	12L1•N 12V1•N	
		=>	12L1•O 12V1•O	

Size4 DRH

NOTE: The "Base" machines are bolded ( es.: 24L2•L ); variant machines are in normal type ( es.: 24L1•L )  
=> Hoist available in the superior FEM (ISO) service group

Key and example of the identifying characteristics of the hoists and trolleys using codes

**DRH Hoist**

Size: 1-2-3-4

N° rope falls:  
2 = 2 falls ( 2/1 )  
4 = 4 falls ( 4/1 )

Type of reducer:  
L = Slow  
4 m/min a 4/1 falls  
8 m/min a 2/1 falls  
V = Fast  
6 m/min a 4/1 falls  
12 m/min a 2/1 falls

FEM group (ISO):  
1 = 1 Am (M4)  
2 = 2 m (M5)  
3 = 3 m (M6)

Capacity letter:  
L = 5000 kg

Type of drum:  
N = Normal  
C = Short  
L = Long  
1 = Extra long - X1 (1a size)  
2 = Extra long - X2 (2a size)  
X = Special

**DST Trolley**

Configuration type Monorail

Size: 1-2-3-4

Version:  
A = Normal  
B = Low headroom  
C = Articulated

Speed of trolley: m/min  
S = 1  
A = 8  
G = 10  
F = 16  
H = 20  
D = 16/4  
W = 20/5

**DRT Trolley**

Configuration type Double girder trolley

Size: 1-2-3

Version:  
A = Hoist on top of trolley  
S = suspended hoist  
R = 1

Trolley speed: m/min  
E = 8  
F = 10  
G = 16  
H = 20  
D = 16/4  
W = 20/5

Gauge: mm  
A = 1000 Normal  
B = 1200 Large  
X = Special

Characteristics and technical data

Capacity (kg)	FEM Group of the hoist	Life service reducers/motors(1)	and Type DRH	Typical wire Hz		data rope Motor	of hoists powerLifting	the height	DRH (m)Speed				Rope(4) N°Ø (mm)	Type of monoraildouble DST - N/RDRT	of glider	trolley
				(m/min.1)	Speed1				Speed2	Speed3	Speed4	Speed5				
800	3m	> 5m	12L3-D	8	8/2,6	3	3/1	8	12	24	34	45	2/1	7B (7B)	1	1
	3m	3m	12V3-D	12	12/4	3	3/1	8	12	24	34	45	2/1	7B (7B)	1	1
1000	3m	> 5m	14L3-E	4	4/1,3	3	3/1	4	6	9	14	19	4/1	7B (7B)	1	1
	3m	5m	14V3-E	6	6/2	3	3/1	4	6	9	14	19	4/1	7B (7B)	1	1
	2m	4m	12L2-E	8	8/2,6	3	3/1	8	12	24	34	45	2/1	7B (7B)	1	1
	3m	4m	12L3-E	8	8/2,6	3	3/1	8	12	24	34	45	2/1	7B (7B)	1	1
	2m	2m	12V2-E	12	12/4	3	3/1	8	12	24	34	45	2/1	7B (7B)	1	1
	3m	4m	22V3-E	12	12/4	5	5/1.65	10	14	26	34	43	2/1	8M (8B)	1	1
1250	3m	> 5m	14L3-F	4	4/1,3	3	3/1	4	6	9	14	19	4/1	7B (7B)	1	1
	3m	4m	14V3-F	6	6/2	3	3/1	4	6	9	14	19	4/1	7B (7B)	1	1
	1Am	3m	12L1-F	8	8/2,6	3	3/1	8	12	24	34	45	2/1	7B (7B)	1	1
	3m	3m	12L3-F	8	8/2,6	3	3/1	8	12	24	34	45	2/1	7M (7A)	1	1
	1Am	1Am	12V1-F	12	12/4	3	3/1	8	12	24	34	45	2/1	7B (7B)	1	1
	2m	3m	22V2-F	12	12/4	5	5/1.65	10	14	26	34	43	2/1	9B (9B)	1	1
	3m	3m	22V3-F	12	12/4	5	5/1.65	10	14	26	34	43	2/1	8M (8B)	1	1
1600	3m	5m	14L3-G	4	4/1,3	3	3/1	4	6	9	14	19	4/1	7B (7B)	1	1
	3m	3m	14V3-G	6	6/2	3	3/1	4	6	9	14	19	4/1	7B (7B)	1	1
	1Am	2m	12L1-G	8	8/2,6	3	3/1	8	12	24	34	45	2/1	7M (7A)	1	1
	2m	2m	12L2-G	8	8/2,6	3	3/1	8	12	24	34	45	2/1	7M (7A)	1	1
	3m	4m	22L3-G	8	8/2,6	5	5/1.65	10	14	26	34	43	2/1	18A (8A)	1	1
	2m	2m	22V2-G	12	12/4	5	5/1.65	10	14	26	34	43	2/1	9B (9B)	1	1
	3m	5m	32V3-G	12	12/4	10	10/3.3	10	14	28	37	47	2/1	12M (12A)	2	2
2000	2m	4m	14L2-H	4	4/1,3	3	3/1	4	6	9	14	19	4/1	7B (7B)	1	1
	3m	4m	14L3-H	4	4/1,3	3	3/1	4	6	9	14	19	4/1	7M (7B)	1	1
	2m	2m	14V2-H	6	6/2	3	3/1	4	6	9	14	19	4/1	7B (7B)	1	1
	3m	4m	24V3-H	6	6/2	5	5/1.65	5	7	10	14	18	4/1	8M (8B)	2	1
	1Am	1Am	12L1-H	8	8/2,6	3	3/1	8	12	24	34	45	2/1	7A (7A)	1	1
	2m	3m	22L2-H	8	8/2,6	5	5/1.65	10	14	26	34	43	2/1	9M (9B)	1	1
	3m	3m	22L3-H	8	8/2,6	5	5/1.65	10	14	-	-	-	2/1	8A	1	1
	1Am	1Am	22V1-H	12	12/4	5	5/1.65	10	14	26	34	43	2/1	9B (9B)	1	1
	2m	4m	32V2-H	12	12/4	10	10/3.3	10	14	28	37	47	2/1	13B (13B)	2	2
	3m	4m	32V3-H	12	12/4	10	10/3.3	10	14	28	37	47	2/1	12M (12A)	2	2
	2500	1Am	3m	14L1-I	4	4/1,3	3	3/1	4	6	9	14	19	4/1	7B (7B)	1
3m		3m	14L3-I	4	4/1,3	3	3/1	4	6	9	14	19	4/1	7M (7A)	1	1
1Am		1Am	14V1-I	6	6/2	3	3/1	4	6	9	14	19	4/1	7B (7B)	1	1
2m		3m	24V2-I	6	6/2	5	5/1.65	5	7	10	14	18	4/1	9B (9B)	2	1
3m		3m	24V3-I	6	6/2	5	5/1.65	5	7	10	14	18	4/1	8M (8B)	2	1
1Am		2m	22L1-I	8	8/2,6	5	5/1.65	10	14	26	34	43	2/1	9M (9A)	1	1
2m		2m	22L2-I	8	8/2,6	5	5/1.65	10	14	26	34	43	2/1	9A (9A)	1	1
3m		5m	32L3-I	8	8/2,6	10	10/3.3	10	14	28	37	47	2/1	12M (12B)	2	2
2m		3m	32V2-I	12	12/4	10	10/3.3	10	14	28	37	47	2/1	13B (13B)	2	2
3m		3m	32V3-I	12	12/4	10	10/3.3	10	14	28	37	47	2/1	12M (12A)	2	2
3200	1Am	2m	14L1-J	4	4/1,3	3	3/1	4	6	9	14	19	4/1	7M (7A)	1	1
	2m	2m	14L2-J	4	4/1,3	3	3/1	4	6	9	14	19	4/1	7A (7A)	1	1
	3m	4m	24L3-J	4	4/1,3	5	5/1.65	5	7	10	14	18	4/1	8A (8A)	2	1
	2m	2m	24V2-J	6	6/2	5	5/1.65	5	7	10	14	18	4/1	9B (9B)	2	1
	3m	5m	34V3-J	6	6/2	10	10/3.3	5	7	10	14	19	4/1	12M (12A)	3	2
	1Am	1Am	22L1-J	8	8/2,6	5	5/1.65	10	14	26	34	43	2/1	9A (9A)	1	1
	2m	4m	32L2-J	8	8/2,6	10	10/3.3	10	14	28	37	47	2/1	13B (13B)	2	2
	3m	4m	32L3-J	8	8/2,6	10	10/3.3	10	14	28	37	47	2/1	12M (12A)	2	2
	2m	2m	32V2-J	12	12/4	10	10/3.3	10	14	28	37	47	2/1	13B (13B)	2	2
	3m	4m	42V3-J	12	12/4	16	16/5.3	12	16	32	45	58	2/1	15M (15A)	3	3
4000	1Am	1Am	14L1-K	4	4/1,3	3	3/1	4	6	9	14	19	4/1	7A (7A)	1	1
	2m	3m	24L2-K	4	4/1,3	5	5/1.65	5	7	10	14	18	4/1	9M (9B)	2	1
	3m	3m	24L3-K	4	4/1,3	5	5/1.65	5	7	10	14	18	4/1	8A	2	1
	1Am	1Am	24V1-K	6	6/2	5	5/1.65	5	7	10	14	18	4/1	9B (9B)	2	1
	2m	4m	34V2-K	6	6/2	10	10/3.3	5	7	10	14	19	4/1	13B (13B)	3	2
	3m	4m	34V3-K	6	6/2	10	10/3.3	5	7	10	14	19	4/1	12M (12A)	3	2
	1Am	3m	32L1-K	8	8/2,6	10	10/3.3	10	14	28	37	47	2/1	13B (13B)	2	2
	2m	3m	32L2-K	8	8/2,6	10	10/3.3	10	14	28	37	47	2/1	13M (13B)	2	2
	3m	3m	32L3-K	8	8/2,6	10	10/3.3	10	14	28	37	47	2/1	12A (12A)	2	2
	1Am	1Am	32V1-K	12	12/4	10	10/3.3	10	14	28	37	47	2/1	13B (13B)	2	2
	2m	3m	42V2-K	12	12/4	16	16/5.3	12	16	32	45	58	2/1	16B (16B)	3	3
3m	3m	42V3-K	12	12/4	16	16/5.3	12	16	32	45	58	2/1	15M (15A)	3	3	



Capacity (kg)	FEM Group of the hoist	Life service reducers/ motors(1)	and Type DRH	Typical wire (m/min, Hz)		data rope Motor (3) (4) (5)	of hoists powerLifting height	the DRH			electric at	Rope(4) N° of falls(mm)		Type of the hoist monorail/double girder DST - N/RDRT			
				Speed1	Speed2			Speed1	Speed2	Speed1		Speed2	Speed1	Speed2	Speed1	Speed2	
5000	1Am	2m	24L1•L	4	4/1,3	5	5/1,65	5	7	10	14	18	4/1	9M (9A)	2	1	
	2m	2m	24L2•L	4	4/1,3	5	5/1,65	5	7	10	14	18	4/1	9A (9A)	2	1	
	3m	5m	34L3•L	4	4/1,3	10	10/3,3	5	7	10	14	19	4/1	12M (12A)	3	2	
	2m	3m	34V2•L	6	6/2	10	10/3,3	5	7	10	14	19	4/1	13B (13B)	3	2	
	3m	3m	34V3•L	6	6/2	10	10/3,3	5	7	10	14	19	4/1	12M (12A)	3	2	
	1Am	2m	32L1•L	8	8/2,6	10	10/3,3	10	14	28	37	47	2/1	13M (13A)	2	2	
	2m	2m	32L2•L	8	8/2,6	10	10/3,3	10	14	28	37	47	2/1	13A (13A)	2	2	
	3m	4m	42L3•L	8	8/2,6	16	16/5,3	12	16	32	45	58	2/1	15M (15A)	3	3	
	2m	2m	42V2•L	12	12/4	16	16/5,3	12	16	32	45	58	2/1	16B (16B)	3	3	
6300	1Am	1Am	24L1•M	4	4/1,3	5	5/1,65	5	7	10	14	18	4/1	9A (9A)	2	1	
	2m	4m	34L2•M	4	4/1,3	10	10/3,3	5	7	10	14	19	4/1	13B (13B)	3	2	
	3m	4m	34L3•M	4	4/1,3	10	10/3,3	5	7	10	14	19	4/1	12M (12A)	3	2	
	2m	2m	34V2•M	6	6/2	10	10/3,3	5	7	10	14	19	4/1	13B (13B)	3	2	
	3m	4m	44V3•M	6	6/2	16	16/5,3	6	8	11	17	24	4/1	15M (15A)	4	3	
	1Am	1Am	32L1•M	8	8/2,6	10	10/3,3	10	14	28	37	47	2/1	13A (13A)	2	2	
	2m	3m	42L2•M	8	8/2,6	16	16/5,3	12	16	32	45	58	2/1	16B (16B)	3	3	
	3m	3m	42L3•M	8	8/2,6	16	16/5,3	12	16	32	45	58	2/1	15A (15A)	3	3	
	1Am	1Am	42V1•M	12	12/4	16	16/5,3	12	16	32	45	58	2/1	16B (16B)	3	3	
8000	1Am	3m	34L1•N	4	4/1,3	10	10/3,3	5	7	10	14	19	4/1	13B (13B)	3	2	
	2m	3m	34L2•N	4	4/1,3	10	10/3,3	5	7	10	14	19	4/1	13M (13B)	3	2	
	3m	3m	34L3•N	4	4/1,3	10	10/3,3	5	7	10	14	19	4/1	12A (12A)	3	2	
	1Am	1Am	34V1•N	6	6/2	10	10/3,3	5	7	10	14	19	4/1	13B (13B)	3	2	
	2m	3m	44V2•N	6	6/2	16	16/5,3	6	8	11	17	24	4/1	16B (16B)	4	3	
	3m	3m	44V3•N	6	6/2	16	16/5,3	6	8	11	17	24	4/1	15M (15A)	4	3	
	1Am	2m	42L1•N	8	8/2,6	16	16/5,3	12	16	32	45	58	2/1	16M (16M)	3	3	
	2m	2m	42L2•N	8	8/2,6	16	16/5,3	12	16	32	45	58	2/1	16A (16M)	3	3	
	10000	1Am	2m	34L1•O	4	4/1,3	10	10/3,3	5	7	10	14	19	4/1	13M (13A)	3	2
2m		2m	34L2•O	4	4/1,3	10	10/3,3	5	7	10	14	19	4/1	13A (13A)	3	2	
3m		4m	44L3•O	4	4/1,3	16	16/5,3	6	8	11	17	24	4/1	15M (15A)	4	3	
2m		2m	44V2•O	6	6/2	16	16/5,3	6	8	11	17	24	4/1	16B (16B)	4	3	
1Am		1Am	42L1•O	8	8/2,6	16	16/5,3	12	16	32	45	58	2/1	16A (16A)	3	3	
12500	1Am	1Am	34L1•P	4	4/1,3	10	10/3,3	5	7	10	14	19	4/1	13A (13A)	3	2	
	2m	3m	44L2•P	4	4/1,3	16	16/5,3	6	8	11	17	24	4/1	16B (16B)	4	3	
	3m	3m	44L3•P	4	4/1,3	16	16/5,3	6	8	11	17	24	4/1	15A (15A)	4	3	
	1Am	1Am	44V1•P	6	6/2	16	16/5,3	6	8	11	17	24	4/1	16B (16B)	4	3	
16000	1Am	2m	44L1•Q	4	4/1,3	16	16/5,3	6	8	11	17	24	4/1	16M (16M)	4	3	
	2m	2m	44L2•Q	4	4/1,3	16	16/5,3	6	8	11	17	24	4/1	16A (16M)	4	3	
20000	1Am	1Am	44L1•R	4	4/1,3	16	16/5,3	6	8	11	17	24	4/1	16A (16A)	4	3	
25000	2m	2m	46L2•S	2,7	2,7/0,9	16	16/5,3	/	5	10	14	/	6/1	16A	/	3(7)	
32000	1Am	1Am	46L1•T	2,7	2,7/0,9	16	16/5,3	/	5	10	14	/	6/1	16A	/	3(7)	
40000	1Am	1Am	48L1•U	2	2/0,7	16	16/5,3	/	4	8	11	/	8/1	16A	/	4(6)	

Electric trolley	travel	Trolley data and motor power (maximums suppliable = kW)															
		1	Speed: 10	8	with m/min.(2)	or	one	motor	and	1	two	Speed: 20	16	2	Speed: 20/5	16/4	or
Type - Size	Reducer ratio with speed m/min 810	Trolley motor TypePower 4 poleskW	Reducer ratio with speed m/min 1620	Trolley motor TypePower 2 poleskW	Reducer ratio with speed m/min 16/420/5	Trolley motor TypePower 2/8 poleskW	Speed: 16/4	or	Speed: 20/5	16/4	or	Speed: 20/5	16/4	or	Speed: 20/5	16/4	or
DST - N/R Monorail	1-2	~1+	~2+	71 - 4	0,16	~1+	~2+	71 - 2	0,32	~1+	~2+	71 - D	0,32/0,08				
	3	~1+	~2+	80 - 4	0,25	~1+	~2+	80 - 2	0,50	~1+	~2+	80 - D	0,50/0,12				
	4	~1+	~2+	80 - 4	0,32	~1+	~2+	80 - 2	0,63	~1+	~2+	80 - D	0,63/0,16				
	1	~1+	~2+	71 - 4	0,16	~1+	~2+	71 - 2	0,32	~1+	~2+	71 - D	0,32/0,08				
DRT double girder	2	~1+	~2+	80 - 4	0,25	~1+	~2+	80 - 2	0,50	~1+	~2+	80 - D	0,50/0,12				
	3	~1+	~2+	100 - 4	0,63	~1+	~2+	100 - 2	1,25	~1+	~2+	100 - D	1,25/0,32				
	4	~1+	~2+	100 - 4	0,63	~1+	~2+	100 - 2	1,25	~1+	~2+	100 - D	1,25/0,32				

Hoist type -->	Breaking load of the ropes (minimum granted kN)																					
	DRH 1			DRH 2			DRH 3			DRH 4												
Ø Rope -->	Ø 7 mm			Ø 8 mm			Ø 9 mm			Ø 12 mm			Ø 13 mm			Ø 15 mm			Ø 16 mm			
Strength classes -->	B	M	A	MA	B	M	A	MA	B	M	A	B	M	A	MA	B	M	A	B	M	A	
Normal (kN)30,4	42,1	48,1	42,0	65,6	53,1	69,6	74,6	121,7	138,7	102,0	142,5	163,4	189,7	219,2	176,9	215,9	236,0					
Non rotating (kN) 35,3	=	48,8	46,1	60,5	58,4	=	76,6	=136,2		121,8	=	159,8	=	212,7	184,4	242,1	255,0					

NOTE: (1) This column indicates the FEM reference group for evaluation of normal conditions and/or the life span of the motored reducer only. The classification of the whole hoist, in any case, is the one defined in the relative FEM service group shown in the adjacent column.  
(2) The lifting and translation speeds and the power of the relative motors are related to a three-phase electrical supply with a frequency of 50 Hz. In the case of a 60 Hz, supply the values need to be increased by 20%.  
(3) The drum N (standard) is available in stock, C (short) L (long) X1 and X2 are available on request.

(4) Hoists with 2 falls of rope (2/1), a long (L) and extra long rope drum size 1 (X1) and hoists with 2 and 4 falls of rope (2/1 e 4/1) and an extra long rope drum size 2 (X2) use anti-twist ropes. The type of anti-twist rope is shown in brackets.  
(5) The extra long drums size 1 (X1) and size 2 (X2) are supplied without the protective roof.  
(6) The trolley is made with two traverse motored reducer. Therefore the power values shown in the table must be doubled.  
(7) he trolley is made with two traverse motored reducer (with motor 80 and powers as DRT2). Therefore the power values shown in the table must be doubled.

Overall dimensions - Weights - Reactions on the supports

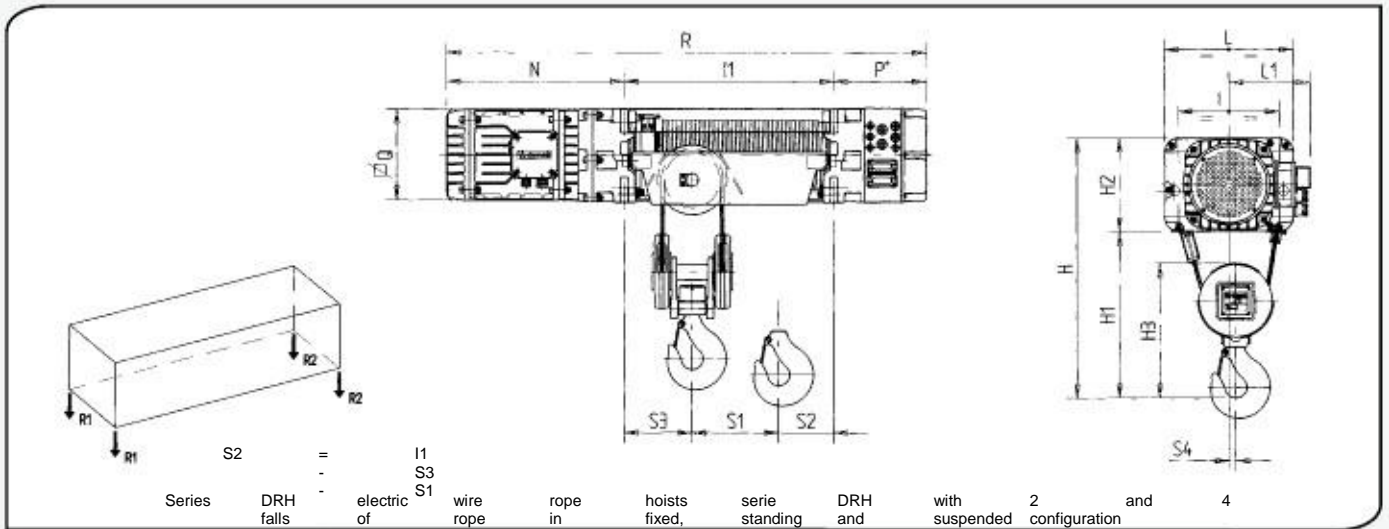

\* DRH3 and DRH4 with Low Voltage Control Box, the dimension P has to be: DRH3 = 330; DRH4 = 360

Falls of rope N°	DRH	Type of drum C-N-L	Hoist weight (kg)	Overall dimensions (mm)														
				H	H1	H2	H3	I	I1	L	L1	R	N	P	Q	S1	S3	S4
2/1	1	C	132	690	460	230	390	250	400	320	210	1135	480	255	225	125	95	28
		N	141	690	460	230	390	250	515	320	210	1250	480	255	225	185	95	28
		L	160	690	460	230	390	250	890	320	210	1625	480	255	225	275	95	28
	2	C	180	820	550	270	445	290	480	370	235	1275	525	270	260	160	100	30
		N	195	820	550	270	445	290	600	370	235	1395	525	270	260	220	100	30
		L	215	820	550	270	445	290	1000	370	235	1795	525	270	260	310	100	30
	3	C	460	1090	710	380	595	370	600	480	290	1510	705	205	300	195	130	40
		N	490	1090	710	380	595	370	740	480	290	1650	705	205	300	265	130	40
		L	565	1090	710	380	595	370	1260	480	290	2170	705	205	300	375	130	40
	4	C	855	1490	920	470	750	460	722	600	360	1797	855	220	340	290	170	45
		N	890	1400	920	470	750	460	862	600	360	1937	855	220	340	290	170	45
		L	1010	1400	920	470	750	460	1422	600	360	2497	855	220	340	400	170	45
4/1	1	C	140	650	420	230	345	250	400	320	210	1135	480	255	225	70	150	15
		N	150	650	420	230	345	250	515	320	210	1250	480	255	225	100	150	15
		L	170	650	420	230	345	250	890	320	210	1625	480	255	225	160	165	15
	2	C	195	750	480	270	390	290	480	370	235	1275	525	270	260	105	180	19
		N	205	750	480	270	390	290	600	370	235	1395	525	270	260	135	180	19
		L	235	750	480	270	390	290	1000	370	235	1795	525	270	260	210	200	19
	3	C	515	1020	640	380	540	370	600	480	290	1510	705	205	300	130	240	23
		N	540	1020	640	380	540	370	740	480	290	1650	705	205	300	160	240	23
		L	625	1020	640	380	540	370	1260	480	290	2170	705	205	300	240	270	23
	4	C	960	1320	860	470	700	460	722	600	360	1797	855	220	340	160	300	25
		N	1000	1320	850	470	700	460	862	600	360	1937	855	220	340	180	300	25
		L	1140	1320	850	470	700	460	1422	600	360	2497	855	220	340	220	300	25

Hoist DRH Capacity kg	Version with 2 falls of rope						
	Static reactions: R1; R2 = daN						
	Drum R1	Drum R2	Drum N	Drum L			
1	800	349	117	373	97	410	69
	1000	425	141	455	115	500	79
	1250	521	170	567	138	611	93
	1600	654	212	699	171	768	111
	2000	806	260	863	207	946	133
	2500	1000	325	1088	265	1197	161
2	3200	1327	363	1398	299	1512	196
	2500	1133	347	1193	302	1309	223
	3200	1407	423	1482	363	1623	259
	4000	1721	509	1812	433	1982	300
	5000	2112	618	2224	521	2430	352
	6300	2621	759	2760	635	3013	419
3	4000	1813	614	1901	543	2097	407
	5000	2195	732	2302	642	2536	468
	6300	2691	886	2823	771	3109	545
	8000	3341	1086	3505	939	3857	647
10000	4104	1323	4308	1136	4738	766	

Hoist DRH Capacity kg	Version with 4 falls of rope						
	Static reactions: R1; R2 = daN						
	Drum R1	Drum R2	Drum N	Drum L			
1	1600	546	324	617	258	708	176
	2000	671	399	759	316	871	213
	2500	826	494	936	380	1074	260
	3200	1046	624	1184	491	1360	324
	4000	1296	774	1468	607	1686	398
	5000	1647	960	1843	760	2118	491
2	3200	1065	632	1188	514	1358	359
	4000	1315	782	1468	634	1678	439
	5000	1627	970	1818	784	2078	539
	6300	2034	1213	2273	979	2596	669
	5000	1672	1086	1870	900	2172	640
	6300	2062	1346	2308	1112	2683	779
3	8000	2572	1686	2882	1388	3351	961
	10000	3172	2086	3558	1712	4137	1175
	12500	3922	2586	4403	2117	5118	1444
	8000	2654	1826	2938	1561	3535	1035
	10000	3237	2243	3589	1910	4324	1246
	12500	3966	2764	4403	2346	5310	1510
4	16000	4987	3493	5543	2956	6690	1880
	20000	6154	4326	6845	3654	8268	2302

## Fixing of the DRH wire rope hoists in suspended or set-down execution

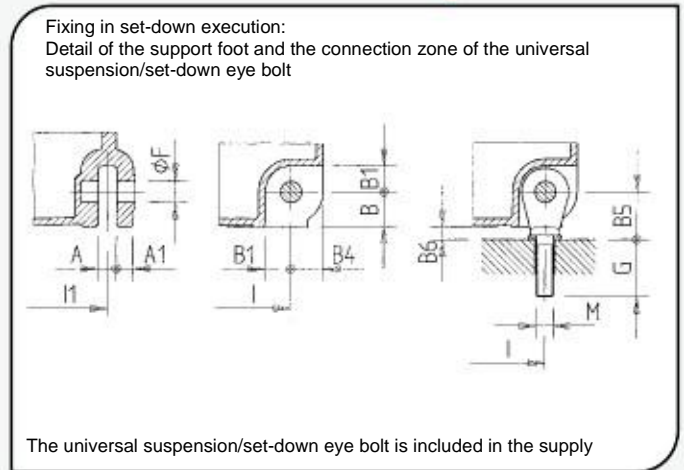
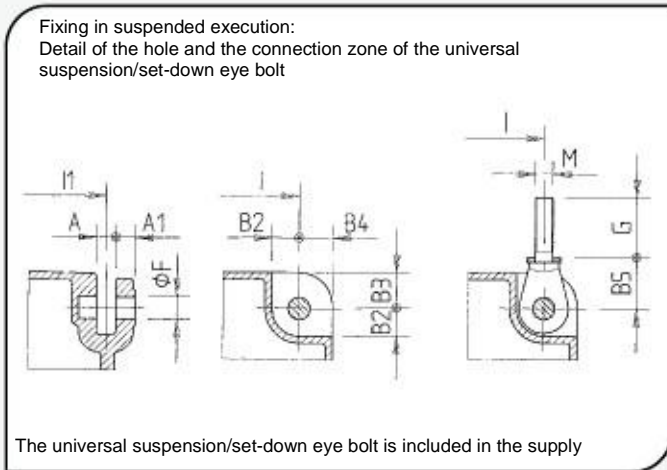

NOTE: Fixing in set-down execution:

- Using the universal eyebolt, the headroom of the hoist (height H2 on page 18), in relation to the level of setting down of the hoist itself, must be increased by the "B6" dimension.

Rope falls N°	DRH	Overall dimensions (mm)												
		A	A1	B	B1	B2	B3	B4	B5	B6	ØF	M	G	
2/1 4/1	1	20	20	37	21	21	35	35	50	13	20	16x2	65	
	2	22	22	42	31	31	40	40	55	13	25	20x2,5	70	
	3	32	32	48	36	36	55	55	76	28	35	24x3	93	
	4	42	42	60	38	46	70	70	89	29	45	30x3,5	108	

### DRH wire rope hoists with extra long drum (X) for high lifting height - Temporary service

The DRH electric wire rope hoists are fitted with electric motors designed for intermittent service, conforming with rule FEM 9.683/95.

In any cases, where it is necessary to extend the running time of the motor beyond the limits allowed by the ratio of intermittence of the lifting motor, as in the case of high hook runs, the running time of the movement can last as long as the allowed limit temperature for the motor is not exceeded. In these cases, instead of the intermittent, use in "temporary service" is required.

For this type of service the hoist must respect the running times for use foreseen for the related FEM group with a maximum number of times started-up not over ten (see table in paragraph 2.2.6). If DRH hoists must be used in temporary service, as well as high lifting height, in addition to the standard versions with drum C - N - L, two sizes of extra long drums (X): 1st size (X1) and 2nd size (X2), are available corresponding to other normalized versions as shown in the table.

DRH	Rope falls	DRH rope hoists with extra long rope drum (X) for									
		Lifting height (m)	DRH rope high (mm)	hoists lifting (mm)	with height (m)	extra long (m)	rope drum (mm)	(X)	S3 (mm)		
1	2/1	34	1200	380	95	45	1530	490	95		
	4/1	14	1200	230	165	19	1530	300	165		
	2/4	34	1260	400	Size 100 2 (Ø2)	1530	490	100			
2	4/1	14	l1 (mm) S1 (mm) S3 (mm) L2 (mm)	490	130	18	1530	350	200		
	2/1	37	1550	280	270	47	1940	620	130		
	4/1	14	1550	280	270	19	1940	350	270		
3	2/1	45	1852	580	170	58	2352	750	170		
	4/1	17	1852	310	300	24	2352	410	300		
4											

### Geometric position of the 4 falls hook-block

DRH electric hoists in the 4 rope falls version with a short (C) or normal (N) rope drum are made as shown in figure 1  
DRH electric hoists in the 4 rope falls version with a long (L) or extra long (X) rope drum are made as shown in figure 2

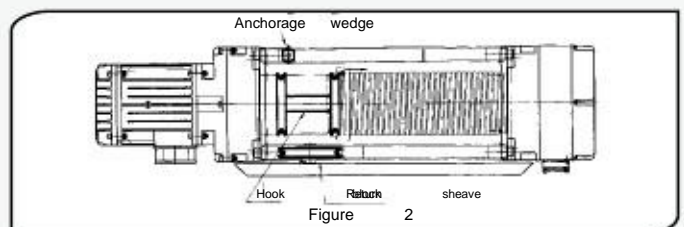
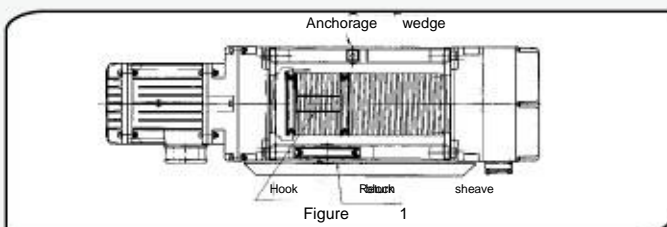

Single girder DST/N/S trolleys for DRH electric wire rope hoists -2 rope falls version (2/1) and 4 rope falls version (4/1)

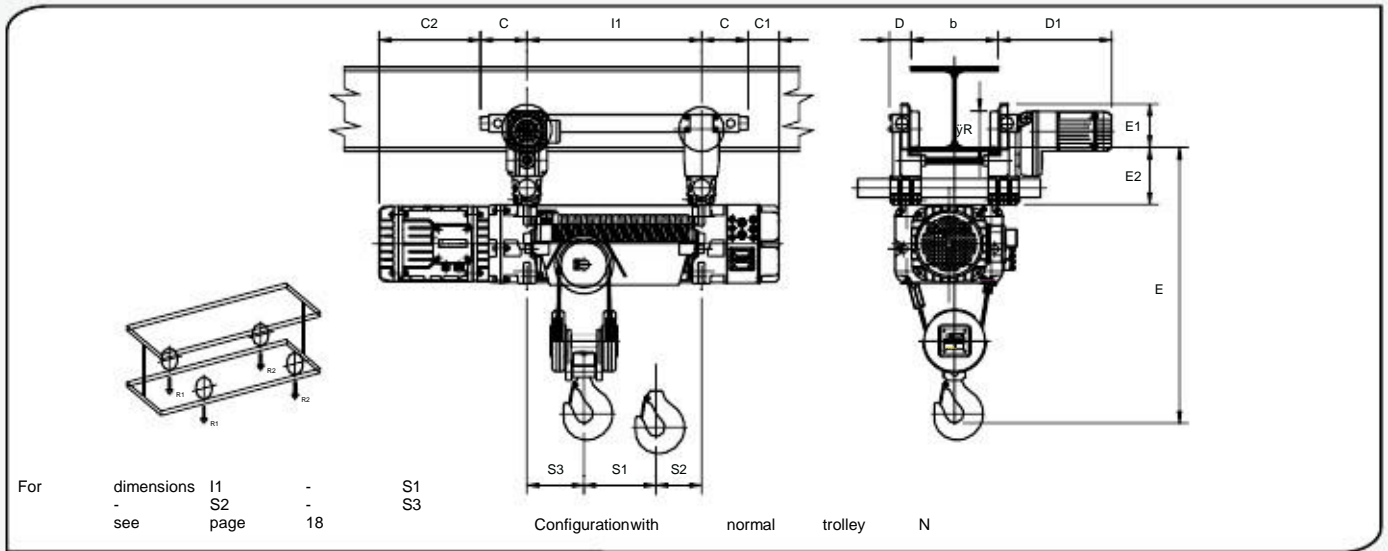

Falls of rope N°	DRH	Type of Trolley drum DRH + DST C-N-L DST N/S (kg)	Overall dimensions (mm)											
			C	C1	C2	D	D1	E	E1	E2	E3	r. min.		
2/1	1	C	1	215	140	115	340	66	385	870	128	180	960	1500
		N	1	220	140	115	340	66	385	870	128	180	960	1500
		L	1	240	140	115	340	66	385	870	128	180	960	1500
	2	C	1	260	140	130	385	66	385	1000	128	180	1090	1500
		N	1	270	140	130	385	66	385	1000	128	180	1090	1500
		L	1	295	140	130	385	66	385	1000	128	180	1090	1500
		C	2	575	160	45	545	75	390	1290	148	195	1400	1600
		N	2	600	160	45	545	75	390	1290	148	195	1400	1600
		L	2	675	160	45	545	75	390	1290	148	195	1400	1600
	3	C	3	1120	275	-55	580	95	455	1670	240	260	1840	1800
		N	3	1155	275	-55	580	95	455	1670	240	260	1840	1800
		L	3	1270	275	-55	580	95	455	1670	240	260	1840	1800
4														
4/1	1	C	1	220	140	115	340	66	385	830	128	180	920	1500
		N	1	230	140	115	340	66	385	830	128	180	920	1500
		L	1	250	140	115	340	66	385	830	128	180	920	1500
	2	C	2	300	160	110	365	75	390	950	148	195	1060	1600
		N	2	310	160	110	365	75	390	950	148	195	1060	1600
		L	2	335	160	110	365	75	390	950	148	195	1060	1600
		C	3	775	275	-70	430	95	455	1290	240	260	1460	1600
		N	3	810	275	-70	430	95	455	1290	240	260	1460	1600
		L	3	880	275	-70	430	95	455	1290	240	260	1460	1600
	3	C	4	1445	325	-108	530	107	465	1620	295	300	1810	1800
		N	4	1455	325	-108	530	107	465	1620	295	300	1810	1800
		L	4	1590	325	-108	530	107	465	1620	295	300	1810	1800
4														

DRH	Hoist Capacity kg	2-rope-fall version (2/1) Static reactions: R1; R2 = daN					
		Drum R1	CDrum R2	NDrum R1	Drum L	CDrum R2	NDrum R1
1	800	377	131	400	110	437	83
	1000	453	155	481	129	527	93
	1250	549	184	583	162	638	107
	1600	682	226	726	184	795	125
	2000	834	274	889	221	973	147
	1250	581	174	611	149	661	112
	1600	720	210	757	178	819	129
2	2000	878	252	923	212	999	149
	2500	1076	304	1132	253	1224	174
	3200	1353	377	1423	312	1530	200
	2500	1171	367	1230	320	1346	242
	3200	1445	443	1519	381	1660	278
3	4000	1759	529	1849	451	2019	319
	5000	2150	638	2261	539	2467	371
	6300	2660	778	2797	653	3050	438
	4000	1901	659	1990	588	2184	451
	5000	2283	777	2391	687	2624	511
	6300	2780	930	2913	815	3196	589
	8000	3429	1131	3595	983	3944	691
10000	4193	1367	4397	1181	4825	810	
4							

DRH	Hoist Capacity kg	4-rope-fall version (4/1) Static reactions: R1; R2 = daN					
		Drum R1	CDrum R2	NDrum R1	Drum L	CDrum R2	NDrum R1
1	1600	573	337	644	271	735	190
	2000	698	412	785	330	898	227
	2500	855	505	963	402	1102	273
	3200	1073	637	1211	504	1387	338
	4000	1323	787	1494	621	1713	412
	2500	881	519	978	427	1112	306
	3200	1100	650	1223	532	1392	376
2	4000	1350	800	1503	652	1712	456
	5000	1663	987	1853	802	2112	556
	6300	2069	1231	2308	997	2632	686
	5000	1758	1130	1959	946	2258	682
	6300	2148	1390	2398	1157	2768	822
3	8000	2658	1730	2973	1432	3436	1004
	10000	3258	2130	3648	1757	4222	1218
	12500	4008	2630	4493	2162	5204	1486
	8000	2805	1903	3090	1638	3685	1110
	10000	3389	2319	3741	1987	4474	1321
	12500	4118	2840	4555	2423	5460	1585
	16000	5139	3569	5695	3033	6840	1955
20000	6305	4403	6997	3731	8417	2378	
4							

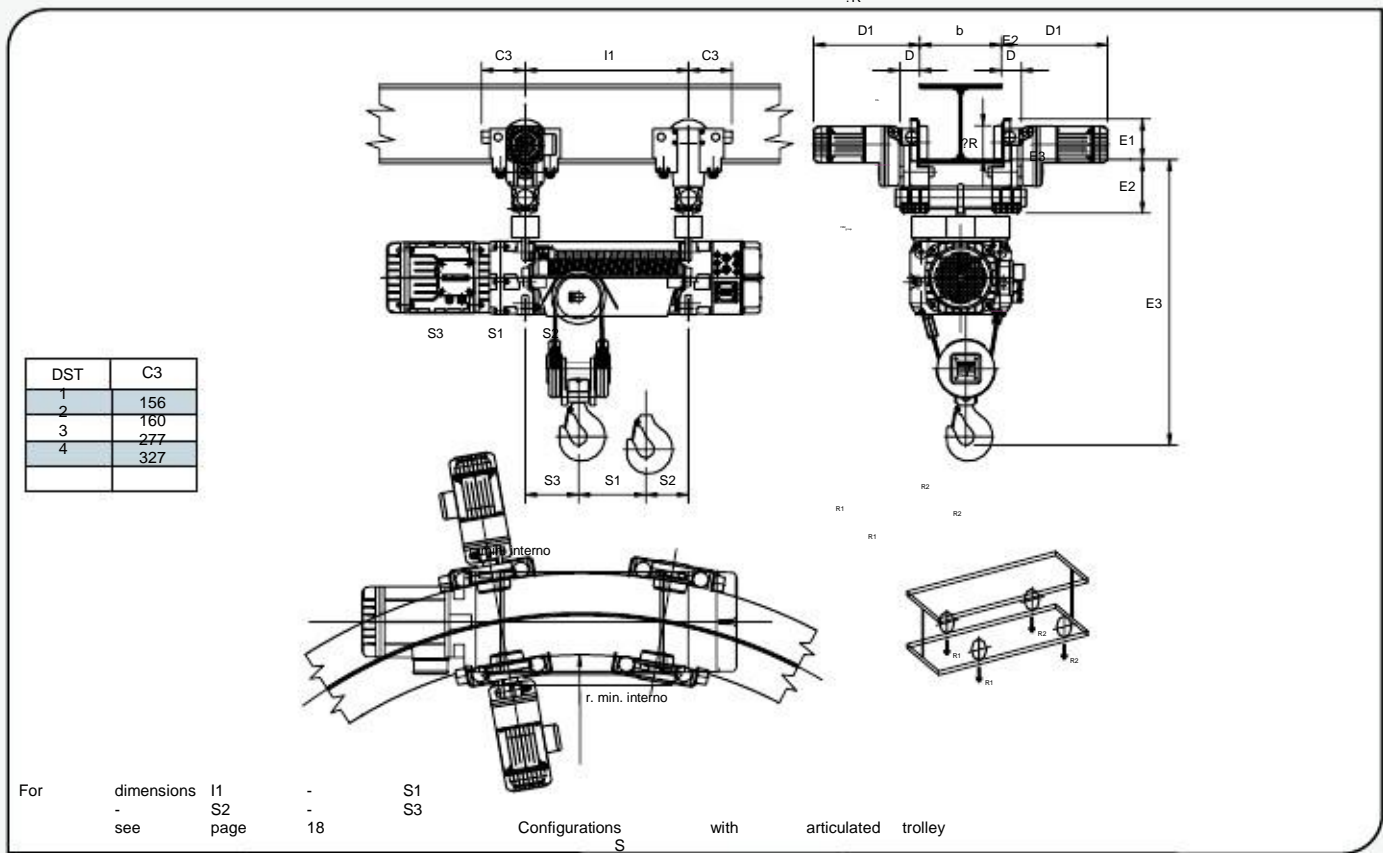

For dimensions I1 - S1 S3  
 - see page 18 S2 - S3  
 Configurations S with articulated trolley

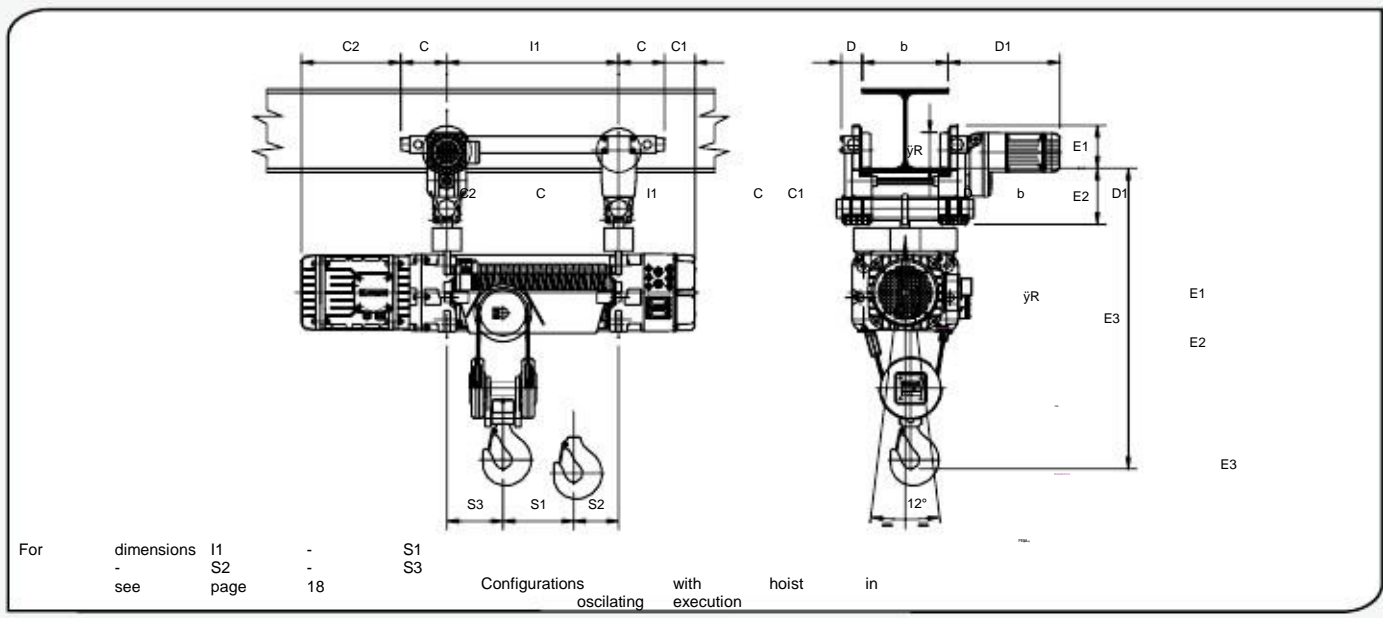

Configurations S1 S3  
 - see page 18 S2 - S3  
 Configurations S oscillating with hoist in execution

DST N/S R	ØR Ruota mm.	Dimensions mm			Thick max. mm.
		i	a	b	
DST 1	100	8	35	18	20
DST 2	125	12	35	29	23
DST 3	200	19	45	38	38
DST 4	250	22	50	43	43

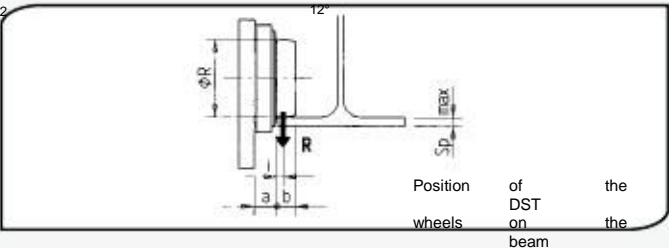

Position of the DST wheels on the beam

BEAMS WIDTH CHARACTERISTICS TABLE FOR DST TROLLEYS												
(mm)	DST1N	DST2N	DST3N	DST4N	DST1R	DST2R	DST3R	DST4R	DST1S/O	DST2S/O	DST3S/O	DST4S/O
Min beam width	90	119	135	170	90	119	135	170	100	135	165	210
Max thickness	20	23	38	43	20	23	38	43	20	23	38	43
Min radius	/	/	/	/	/	/	/	/	1500	1600	1600	1800

Minimum beam's needed width = minimum beam width  
 Maximum thickness= maximum allowed beam bottom flange  
 Minimum radius = minimum internal radius required for curved beams  
 N= normal; R= low headroom; S= articulated; O= oscillating

Monorail DST/R trolleys for electric DRH wire rope hoists – 2 rope falls (2/1) and 4 rope falls versions (4/1)

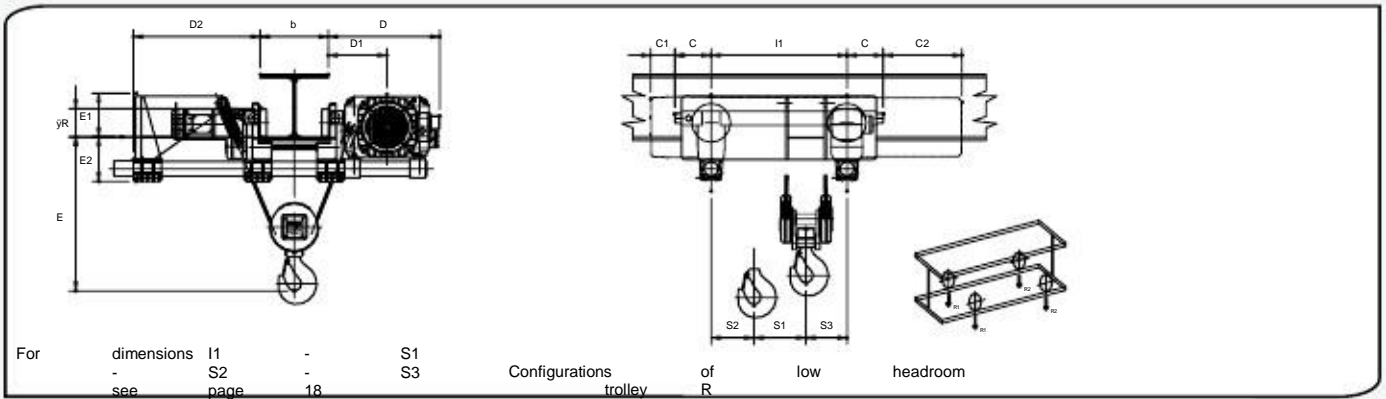

Rope falls N°	DRH	Type of drum C-N-L	Trolley DST/R	Weight DRH+DST (kg)	Overall dimensions (mm)								
					D	D1	D2	E1	E2	ØR	C	C1	C2
2/1	1	C	1	260	440	230	540	140	180	100	140	115	340
		N	1	270	440	230	540	140	180	100	140	115	340
		L	1	280	440	230	540	140	180	100	140	115	340
		C	1	360	485	250	590	200	180	100	140	130	385
	2	N	1	370	485	250	590	200	180	100	140	130	385
		L	1	395	485	250	590	200	180	100	140	130	385
		C	2	740	605	315	655	315	195	125	160	45	545
		N	2	770	605	315	655	315	195	125	160	45	545
	3	L	2	870	605	315	655	315	195	125	160	45	545
		C	3	1610	765	395	677	345	260	200	275	-55	580
		N	3	1550	755	395	677	345	260	200	275	-55	580
		L	3	1700	755	395	677	345	260	200	275	-55	580
4/1	1	C	1	270	440	230	540	140	180	100	140	115	340
		N	1	280	440	230	540	140	180	100	140	115	340
		L	1	290	440	230	540	140	180	100	140	115	340
		C	2	415	495	265	560	195	195	125	160	110	365
	2	N	2	425	495	265	560	195	195	125	160	110	365
		L	2	450	495	265	560	195	195	125	160	110	365
		C	3	985	625	335	622	280	260	200	275	-70	430
		N	3	1005	625	335	622	280	260	200	275	-70	430
	3	L	3	1115	625	335	622	280	260	200	275	-70	430
		C	4	1880	760	405	630	345	300	250	325	-108	530
		N	4	1930	760	405	630	345	300	250	325	-108	530
		L	4	2120	760	405	630	345	300	250	325	-108	530

Rope Falls N°	Hook clearance (mm)	E and (mm) to the relation size of the width DRH of wire the rope beam hoist b
1	b = 180 mmb = 220 mmb = 300 mmb = 400 mm	
2/1	23412341234123	630 480
4/1	500610790530550610790620650650790740770770	1000 850

Hoist DRH Capacity kg	2-rope-falls version (2/1)						
	Static reactions: R1; R2 = daN	Drum CD	Drum ND	Drum L	R1R2	R1R2R1R2	R1R2
800	392	138	416	119	451	89	
1000	468	162	498	137	540	100	
1250	563	192	600	160	662	143	
1600	697	233	742	193	808	132	
2000	849	281	906	229	987	153	
1250	615	190	644	166	695	128	
1600	753	227	790	195	852	146	
2000	912	268	957	228	1032	166	
2500	1110	320	1165	270	1257	191	
3200	1387	393	1467	328	1672	226	
2500	1226	394	1287	348	1411	274	
3200	1500	470	1576	409	1725	310	
4000	1813	557	1905	480	2084	351	
5000	2205	665	2317	568	2532	403	
6300	2714	806	2853	682	3115	470	
4000	2031	724	2121	654	2327	523	
5000	2413	842	2522	753	2767	583	
6300	2910	995	3044	881	3340	660	
8000	3559	1196	3726	1049	4088	762	
10000	4323	1432	4528	1247	4968	882	

Hoist DRH Capacity kg	4-rope-falls version (4/1)						
	Static reactions: R1; R2 = daN	Drum CD	Drum ND	Drum L	R1R2	R1R2R1R2	R1R2
1600	590	345	660	280	748	197	
2000	715	420	802	338	911	234	
2600	871	514	970	411	1146	280	
3200	1090	645	1227	513	1400	345	
4000	1340	795	1511	629	1726	419	
2500	920	536	1017	446	1150	325	
3200	1139	669	1262	551	1430	395	
4000	1389	819	1542	671	1750	475	
5000	1701	1007	1892	821	2150	575	
6300	2107	1261	2347	1016	2670	706	
5000	1829	1164	2024	979	2336	722	
6300	2219	1424	2464	1189	2847	861	
8000	2729	1764	3038	1465	3515	1043	
10000	3329	2164	3714	1789	4300	1258	
12500	4079	2664	4558	2195	5283	1525	
8000	2960	1980	3248	1717	3862	1198	
10000	3543	2397	3899	2066	4656	1410	
12500	4273	2917	4713	2502	5636	1674	
16000	5293	3647	5853	3112	7017	2043	
20000	6460	4480	7155	3810	8594	2466	

DRT double girder trolleys for electric DRH wire rope hoists – 2 rope falls (2/1) and 4 rope falls versions (4/1)

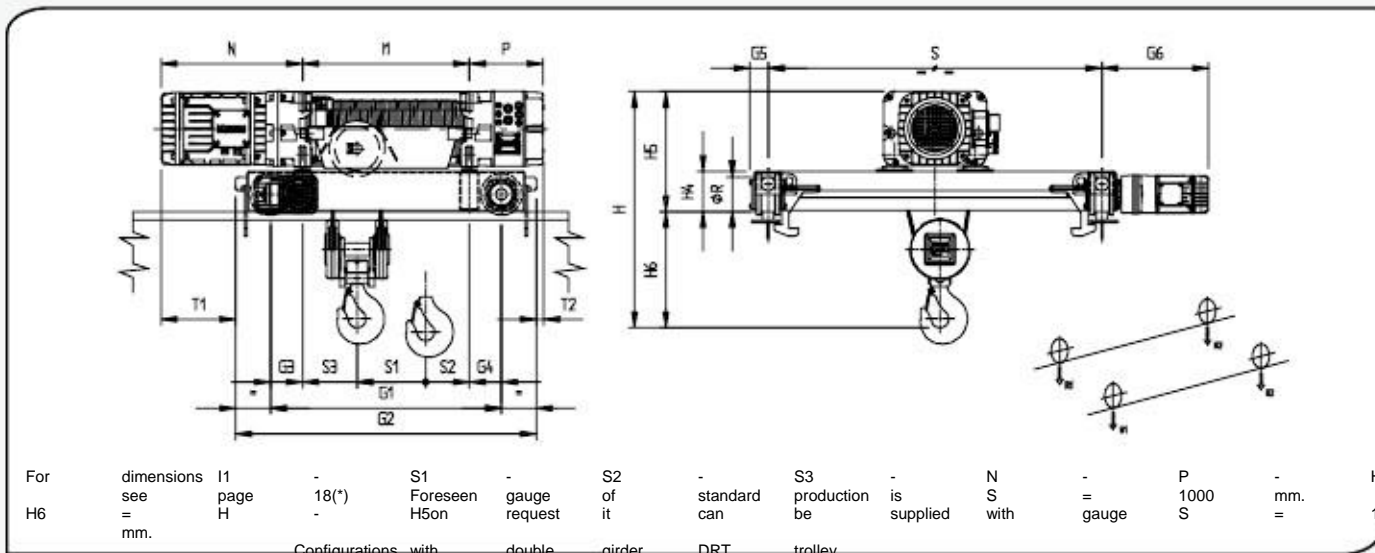

Rope falls N°	DRH	Type of drum C-N-L	Trolley DRT	Weight DRH+DRT (kg)	G1	G2	G3	G4	G5	G6	T1	T2	S	ØR	H4	H5
2/1 4/1	1	C	1	236	710	940	155	155	66	385	210	-15	1000	125	145	391
		N	1	250	830	1060	157.5	157.5	66	385	207.5	-17.5	1000	125	145	391
		L	1	280	1230	1460	170	170	66	385	195	-30	1000	125	145	391
	2	C	1	296	710	940	115	115	66	385	295	40	1000	125	145	433
		N	1	306	830	1060	115	115	66	385	295	40	1000	125	145	433
		L	1	350	1230	1460	115	115	66	385	295	40	1000	125	145	433
	3	C	2	716	890	1202	145	145	80	455	404	-96	1000	160	190	598
		N	2	750	1030	1342	145	145	80	455	404	-96	1000	160	190	598
		L	2	860	1550	1862	145	145	80	455	404	-96	1000	160	190	598
	4	C	3	1240	1060	1446	170	170	90	520	492	-143	1000	200	228	720
		N	3	1286	1200	1586	170	170	90	520	492	-143	1000	200	228	720
		L	3	1480	1760	2146	170	170	90	520	492	-143	1000	200	228	720

Hoist DRH Capacity kg	2-rope-falls version (2/1)						
	Static reactions: R1; R2 = daN						
	Drum C	Drum N	Drum L	R1R2	R1R2	R1R2	R1R2
1	800	335	179	359	162	404	131
	1000	400	214	428	193	482	153
	1250	481	258	515	231	580	180
	1600	594	320	637	284	718	217
	2000	724	390	776	345	875	260
	2500	865	476	934	418	1058	313
2	1600	651	289	691	257	770	195
	2000	791	349	839	309	935	230
	2500	965	425	1025	373	1142	273
	3200	1209	531	1284	464	1430	336
	2500	1084	496	1146	449	1295	355
	3200	1326	604	1403	542	1583	417
3	4000	1602	728	1696	649	1912	488
	5000	1948	882	2063	782	2323	577
	6300	2397	1083	2539	956	2858	692
	4000	1737	831	1825	763	2064	611
	5000	2077	991	2184	904	2467	708
	6300	2518	1200	2649	1089	2991	834
4	8000	3096	1472	3259	1329	3677	998
	10000	3775	1793	3975	1613	4484	1191

Hoist DRH Capacity kg	4-rope-falls version (4/1)						
	Static reactions: R1; R2 = daN						
	Drum C	Drum N	Drum L	R1R2	R1R2	R1R2	R1R2
1	1600	535	383	587	338	675	265
	2000	649	469	713	412	821	319
	2500	792	576	870	505	1003	387
	3200	992	726	1090	635	1258	482
	4000	1220	898	1342	783	1549	591
	2500	830	568	908	495	1047	378
2	3200	1034	714	1133	620	1307	468
	4000	1268	880	1391	762	1605	570
	5000	1560	1088	1713	940	1977	698
	6300	1940	1358	2133	1170	2460	865
	5000	1658	1200	1815	1060	2117	813
	6300	2026	1482	2223	1302	2593	987
3	8000	2508	1850	2755	1620	3216	1214
	10000	3076	2282	3381	1994	3948	1482
	12500	3785	2823	4164	2461	4863	1817
	8000	2640	1980	2862	1781	3425	1315
	10000	3196	2424	3470	2173	4158	1582
	12500	3892	2978	4230	2663	5074	1916
4	16000	4866	3754	5295	3348	6357	2383
	20000	5979	4641	6512	4131	7823	2917

Dimensions of the relevant rails the DRT wheels and

DRT	ØR Wheel mm.	Dimensions mm						
		Wheel				H min	Rail B min	B max
		A	B	C	Øe			
DRT 1	125	50	15	80	150	30	30	40
DRT 2	160	55	19	93	190	30	30	45
DRT 3	200	60	20	100	230	30	40	50

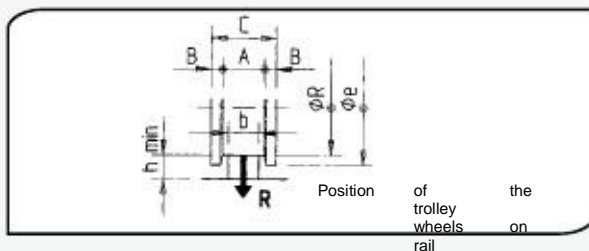

DRT double girder trolleys for DRH wire rope hoist suspended execution - Version 2 rope falls and 4 rope falls

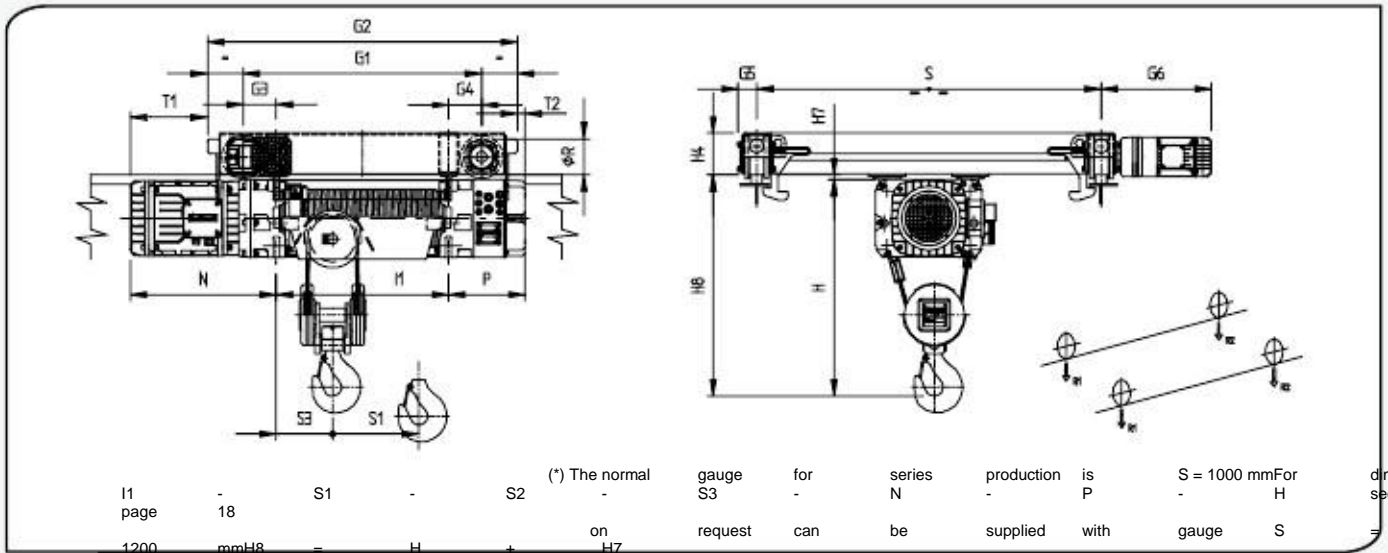

Falls of rope N°	DRH	Drum type C-N-L	Trolley DRT	Weight DRH+DRT (kg)	G1	G2	G3	G4	G5	G6	T1	T2	S	ØR	H4	H7
2/1 4/1	1	C	1	236	710	940	155	155	66	385	210	-15	1000	125	145	13
		N	1	250	830	1060	157.5	157.5	66	385	207.5	-17.5	1000	125	145	13
		L	1	280	1230	1460	170	170	66	385	196	30	1000	125	146	13
	2	C	1	296	710	940	115	115	66	385	295	40	1000	125	145	15
		N	1	306	830	1060	115	115	66	385	295	40	1000	125	145	15
		L	1	350	1230	1460	115	115	66	385	295	40	1000	125	145	15
	3	C	2	716	890	1202	145	145	80	455	404	-96	1000	160	190	11
		N	2	750	1030	1342	145	145	80	455	404	-96	1000	160	190	11
		L	2	860	1550	1862	145	145	80	455	404	-96	1000	160	190	11
	4	C	3	1240	1060	1446	170	170	90	520	492	-143	1000	200	228	11
		N	3	1286	1200	1586	170	170	90	520	492	-143	1000	200	228	11
		L	3	1480	1760	2146	170	170	90	520	492	-143	1000	200	228	11

Hoist DRH Capacity kg	Version (2/1) with 2 rope falls						
	Static reactions; R1; R2 = daN						
	Drum C	Drum N	Drum L	R1 R2 R1 R2			
1	800	335	179	359	162	404	131
	1000	400	214	428	193	482	153
	1250	481	258	515	231	580	180
	1600	594	320	637	284	718	217
	2000	724	390	776	345	875	260
	2500	865	471	931	416	1058	313
2	1600	651	289	691	257	770	195
	2000	791	349	839	309	935	230
	2500	965	425	1025	373	1142	273
	3200	1209	531	1284	464	1430	335
	2500	1084	496	1146	449	1295	355
	3200	1326	604	1403	542	1583	417
3	4000	1602	728	1696	649	1912	488
	5000	1948	882	2063	782	2323	577
	6300	2397	1083	2539	956	2858	692
	4000	1737	831	1825	763	2064	611
	5000	2077	991	2184	904	2467	708
	6300	2518	1200	2649	1089	2991	834
4	8000	3096	1472	3259	1329	3677	998
	10000	3775	1793	3975	1613	4484	1191

Hoist DRH Capacity kg	Version (4/1) with 4 rope falls						
	Static reactions; R1; R2 = daN						
	Drum C	Drum N	Drum L	R1 R2 R1 R2			
1	1600	535	383	587	338	675	265
	2000	649	469	713	412	821	319
	2500	792	576	870	505	1003	387
	3200	992	726	1090	635	1258	482
	4000	1220	898	1342	783	1549	591
	2500	896	646	908	495	1047	378
2	3200	1034	714	1133	620	1307	468
	4000	1268	880	1391	762	1605	570
	5000	1560	1088	1713	940	1977	698
	6300	1940	1358	2133	1170	2460	865
	5000	1658	1200	1815	1060	2117	813
	6300	2026	1482	2223	1302	2593	987
3	8000	2508	1850	2755	1620	3216	1214
	10000	3076	2282	3381	1994	3948	1482
	12500	3785	2823	4164	2461	4863	1817
	8000	2640	1980	2862	1781	3425	1315
	10000	3196	2424	3470	2173	4156	1582
	12500	3892	2978	4230	2663	5074	1916
4	16000	4866	3754	5295	3348	6357	2383
	20000	5979	4641	6512	4131	7823	2917

DRT wheels dimensions and relevant rails

DRT	ØR Wheel mm.	Dimensions mm						
		A	B	C	Øe	H min	B max	
DRT 1	125	50	15	80	150	30	30	40
DRT 2	160	55	19	93	190	30	30	45
DRT 3	200	60	20	100	230	30	40	50

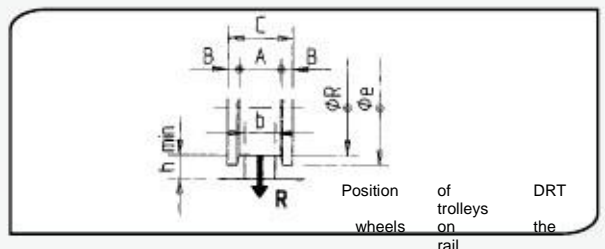



DRT double girder trolley for DRH wire rope hoist in trasversal position with 2 rope falls (2/1) and 4 rope falls (4/1)

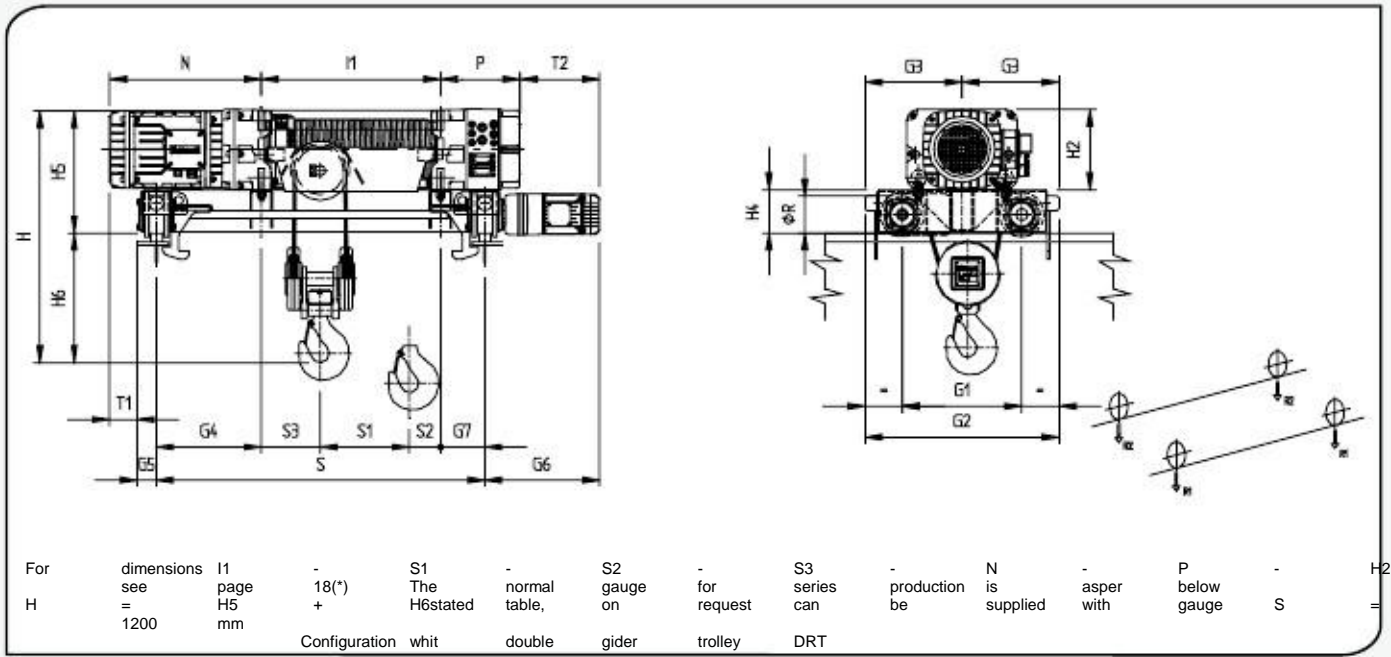

Falls of rope N°	DRH	Drum type C-N-L	Trolley DRT	Weight DRH+DRT (kg)	G1	G2	G3	G4	G5	G6	G7	T1	T2	S	ØR	H4	H5	H6	
																		2 rope	4 rope
1	C	1	1	216	400	630	315	315	66	385	285	99	415	1000	125	145	375	405	360
	N	1	1	226	400	630	315	300	66	385	185	114	315	1000	125	145	375	405	360
	L	1	1	270	740	940	470	110	66	385	0	304	130	1000	125	145	375	346	276
	C	1	1	276	400	630	315	267	66	385	253	192	368	1000	125	145	415	485	425
	N	1	1	286	400	630	315	252	66	385	148	207	263	1000	125	145	415	485	425
	L	1	1	346	710	940	470	200	66	385	0	259	115	1200	125	145	415	405	335
2/1	C	2	2	660	500	812	406	195	80	455	205	431	455	1000	160	190	570	630	570
	N	2	2	686	500	812	406	180	80	455	90	446	340	1000	160	190	570	630	570
	L	2	2	830	890	1202	601	140	80	455	0	486	250	1400	160	190	570	520	450
	C	3	3	1190	600	986	493	140	90	520	140	625	440	1000	200	228	698	768	722
	N	3	3	1240	600	986	495	200	90	520	140	565	440	1200	200	228	698	768	722
	L	3	3																
4/1	C	3	3	1490	600	986	493	140	90	520	140	625	440	1000	200	228	698	768	722
	N	3	3	1240	600	986	495	200	90	520	140	565	440	1200	200	228	698	768	722
	L	3	3																
	C	3	3																
	N	3	3																
	L	3	3																
4																			

Hoist DRH Capacity kg	Version with 2 rope falls (2/1)						
	Static reactions; R1; R2 = daN						
	Drum R1	Drum R2	Drum N	Drum L			
800	305	199	313	194	405	125	
1000	364	240	374	233	484	146	
1250	438	291	450	282	584	171	
1600	541	363	555	352	723	207	
2000	659	445	676	431	882	248	
1250	482	273	494	264	577	211	
1600	593	337	607	326	709	254	
2000	720	410	737	396	859	304	
2500	878	502	899	484	1046	367	
3200	1100	630	1126	608	1309	464	
2500	1046	507	1084	479	1266	369	
3200	1282	621	1329	584	1548	437	
4000	1552	751	1609	704	1871	514	
5000	1890	913	1959	854	2275	610	
6300	2328	1125	2414	1049	2800	735	
4000	1802	741	1810	755			
5000	2162	881	2168	897			
6300	2630	1063	2634	1081			
8000	3242	1301	3243	1322			
10000	3962	1581	3960	1605			
4							

Hoist DRH Capacity kg	Version with 4 rope falls (4/1)						
	Static reactions; R1; R2 = daN						
	Drum R1	Drum R2	Drum N	Drum L			
1600	500	408	515	398	670	265	
2000	607	501	625	488	815	320	
2500	741	617	763	600	996	389	
3200	928	780	955	758	1250	485	
4000	1142	966	1175	938	1540	595	
2500	783	605	805	586	949	474	
3200	977	761	1004	739	1182	591	
4000	1198	940	1231	912	1449	724	
5000	1475	1163	1515	1128	1782	891	
6300	1834	1454	1885	1408	2215	1108	
5000	1633	1197	1704	1139	2045	870	
6300	2000	1480	2087	1406	2504	1061	
8000	2480	1850	2589	1754	3105	1310	
10000	3045	2285	3179	2164	3812	1603	
12500	3752	2828	3916	2677	4696	1969	
8000	2757	1838	2847	1773			
10000	3347	2246	3455	2165			
12500	4085	2760	4215	2655			
16000	5117	3478	5280	3340			
20000	6297	4298	6497	4123			
4							

DRT wheels dimensions and relevant rails

DRT	ØR Wheel mm.	Dimensions mm						
		Wheel				H min	Rail B min	B max
A	B	C	Øe					
DRT 1	125	50	15	80	150	30	30	40
DRT 2	160	55	19	93	190	30	30	45
DRT 3	200	60	20	100	230	30	40	50

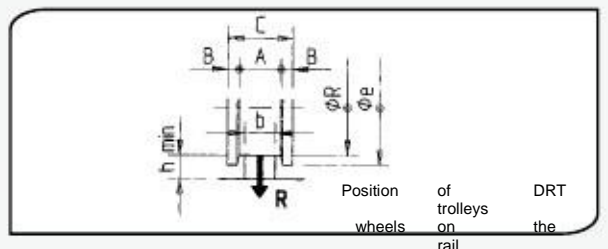

DRT double girder trolley for DRH wire rope hoist - Version with 6 rope falls (6/1) and 8 rope falls (8/1)

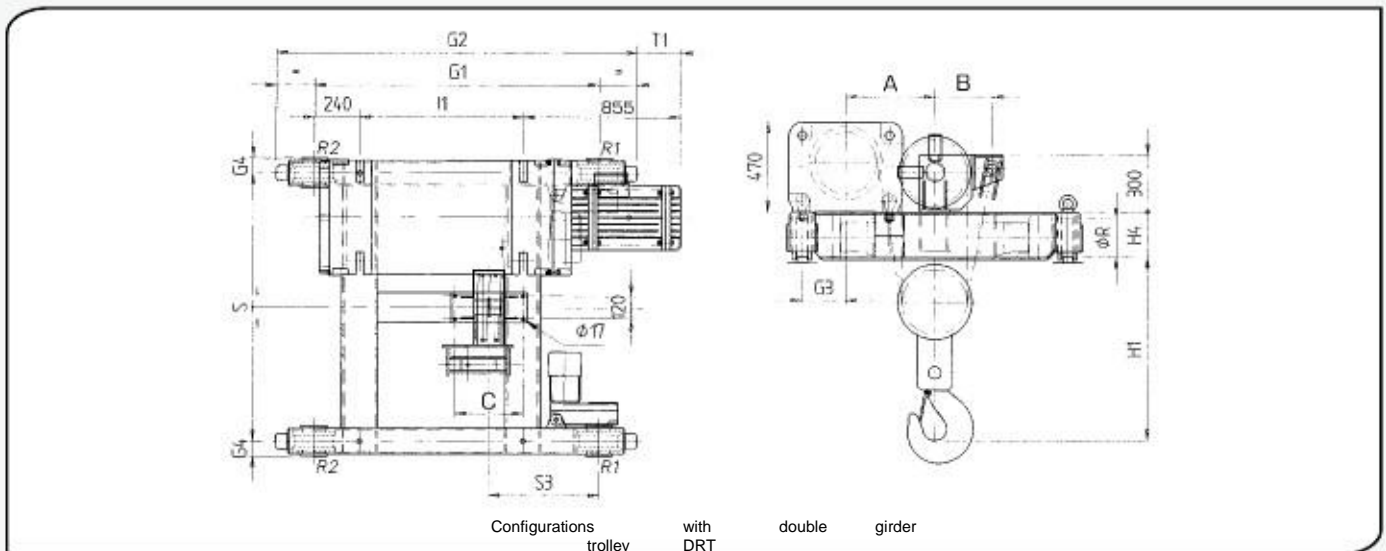

Falls of rope N°	DRH	Drum Trolley Weight type DRH+DRT N-L-X1DRT(kg)	Overall dimensions (mm)														
			G1	G2	G3	G4	S3	S	T1	H1	H4	ØR	A	B	C		
6	4	N	3	1800	1500	1900	230	90	580	1400	255	960	235	200	470	300	360
		N	3	2100	1500	1900	650	90	580	2240	255	960	235	200	470	300	360
		N	3	2400	1500	1900	930	90	580	2800	265	960	236	200	470	300	360
6	4	L	3	2000	2070	2470	230	90	590	1400	245	960	235	200	470	300	360
		L	3	2300	2070	2470	650	90	590	2240	245	960	235	200	470	300	360
		L	3	2700	2070	2470	930	90	590	2800	245	960	235	200	470	300	360
6	4	X1	3	2250	2500	2900	230	90	590	1400	245	960	235	200	470	300	360
		X1	3	2500	2500	2900	650	90	590	2240	245	960	235	200	470	300	360
		X1	3	2800	2500	2900	930	90	590	2800	245	960	235	200	470	300	360
6	4	N	4	2000	1500	1950	230	97	688	1400	230	930	287	250	470	400	556
		N	4	2400	1500	1950	550	97	688	2240	230	930	287	250	570	400	556
		N	4	2600	1500	1950	830	97	688	2800	230	930	287	250	570	400	556
8	4	L	4	2300	2060	2510	230	97	708	1400	230	930	287	250	470	400	556
		L	4	2600	2060	2510	550	97	708	2240	230	930	287	250	570	400	556
		L	4	2800	2060	2510	830	97	708	2800	230	930	287	250	570	400	556
8	4	X1	4	2500	2500	2950	230	97	738	1400	220	930	287	250	470	400	556
		X1	4	2900	2500	2950	550	97	738	2240	220	930	287	250	570	400	556
		X1	4	3100	2500	2950	830	97	738	2800	220	930	287	250	570	400	556
8	4																
8	4																

Hoist DRH 4 DRT 3 Capacity Skg	Version with 6 rope falls						
	Static reactions: R1; R2 = daN						
	Drum N	Drum L	Drum X1	R1	R2	R1R2	R1R2
1400	25000	8250	5150	9600	3900	10250	3375
	32000	10400	6500	12100	4900	10950	4175
	25000	8350	5200	9700	3950	10350	3400
2240	32000	10500	6550	12200	4950	13050	4200
	25000	8450	5250	9800	4050	10400	3500
	32000	10600	6600	12300	5050	13100	4300
2800							

Hoist DRH 4 DRT 4 Capacity Skg	Version with 8 rope falls						
	Static reactions: R1; R2 = daN						
	Drum N	Drum L	Drum X1	R1	R2	R1R2	R1R2
1400	40000	11500	9500	13850	7300	14900	6350
	22400	40000	11600	9600	13950	7350	6400
	28000	40000	11650	9650	14000	7400	6450

DRT	ØR Wheel mm.	DRT wheels dimensions and relevant rails						
		Dimensions mm						
		A	B	C	Øe	h min	Rail b min	b max
DRT 3	200	60	20	100	230	30	40	50
DRT 4	250	70	20	110	280	40	50	60

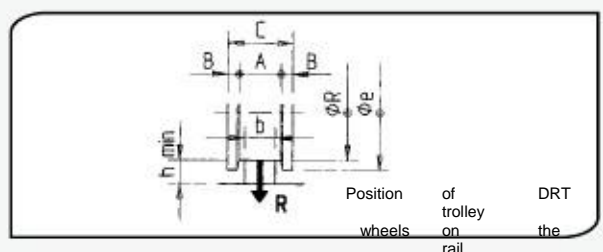

# Characteristics of the motors, fuses and power cables

Hoist DRH	Motor Type	Poles	Group FEM	Power kW	COSφ	Ia 400V	- In (A) 400V - 50Hz	- (A) - 50Hz	Power current fuse (A) - 50Hz	Minimum of 400V	section power -	cables (□U20V)	C mm <sup>2</sup>
DRH 1	112K4RH1/3	4	1Am 2m 3m 1Am	3	0,75	40	8	16	2,5	=m	≤ 30	L	
	112K5RH1/3	4/12	2m 3m 1Am 2m	3/1	0,72/0,5	38/13	8/6,6	16	2,5		≤ 30		
DRH 2	132K4RH2/3	4	3m 1Am 2m 3m	5	0,75	58	12	20	4		≤ 30		
	132K5RH2/3	4/12	1Am 2m 3m 1Am	5/1,65	0,78/0,5	50/17	12/10	20	4		≤ 30		
DRH 3	160K4RH3/2	4	2m 3m 1Am 2m	10	0,8	110	22	32	6		≤ 30		
	160K5RH3/2	4/12	3m 1Am 2m 3m	10/3,3	0,77/0,46	100/20	24/18	32	6		≤ 30		
DRH 4	180K4RH4/2	4	1Am 2m 3m	16	0,82	175	34	63	10		≤ 20		
	180K5RH4/2	4/12		16/5,3	0,78/0,46	170/50	38/25	63	10		≤ 20		

Trolley DST DRT	Motor Type	Poles	Group FEM	Power kW	COSφ	Ia 400V	- (A) - 50Hz	In 400V	- (A) - 50Hz
DST 1 DST 2 DRT 1	71K3P	2/8	1Am 2m 3m 1Am	0,32/0,07	0,7/0,55	3,8/1,2		1,0/0,8	
	71C2P	2	2m 3m 1Am 2m	0,32	0,72	6		1,0	
	71C4P	4	3m 1Am 2m 3m	0,16	0,5	4		1,0	
DST 3 DRT 2	80K3P	2/8	1Am	0,5/0,12	0,85/0,6	5,5/1,6		1,3/1,1	
	80K2P	2	2m	0,50	0,6	5,6		1,3	
	80K4P	4	3m	0,25	0,65	3,3		0,9	
DST4 * DRT3 (DRH4 6 falls)	80K3PL	2/8	1Am	0,63/0,15	0,82/0,57	6,8/1,9		1,6/1,3	
	80K2PL	2	2m	0,63	0,75	7,7		1,7	
	80K4PL	4	3m 1Am 2m 3m	0,32	0,65	3,9		1,1	
DRT 3 *DRT4	100K3P	2/8	1Am 2m 3m	1,25/0,31	0,84/0,6	16/3,6		3,1/1,8	
	100K2P	2		1,25	0,83	16		2,9	
	100K4P	4		0,63	0,8	8,5		1,7	

\* The trolley is made with two travel motoreducers. The powers values shown in the table must be doubled.

Example calculation of a fall in tension □Y, of the length and of the section of the power cable. (ΔU max 5%)

$$\square Y = 1,73 \cdot L \cdot I_a \cdot \cos \phi / X \cdot O \quad [V]$$

$$L = \square Y \cdot X \cdot O / 1,73 \cdot \cos \phi \cdot I_a \quad [m]$$

$$|O = 1,73 \cdot L \cdot I_a \cdot \cos \phi / \square Y \cdot X \quad [mm^2]$$

Values in the formula:

- Y = Fall in tension [V]
- Ia = Start-up current [A]
- L = Length of cable [m]
- |O = Section of the cable [mm<sup>2</sup>]
- X = Conductivity Cu=57 m/Qmm
- cosφ = Power factor

since 1930

11/07

ArtesAmpA  
Galliate Lomba



Supplied By

**CRANE HANDLING**

AN16CG07

Unit 17C Gainsborough Trading Estate, Rufford Road, Stourbridge, West Midlands, DY9  
7ND 01384 441235 [www.cranehandling.com](http://www.cranehandling.com) [sales@cranehandling.com](mailto:sales@cranehandling.com)



ISO 9001  
Cert. n. 0114

