

Operation Manual

SWS83 Storage wire saw

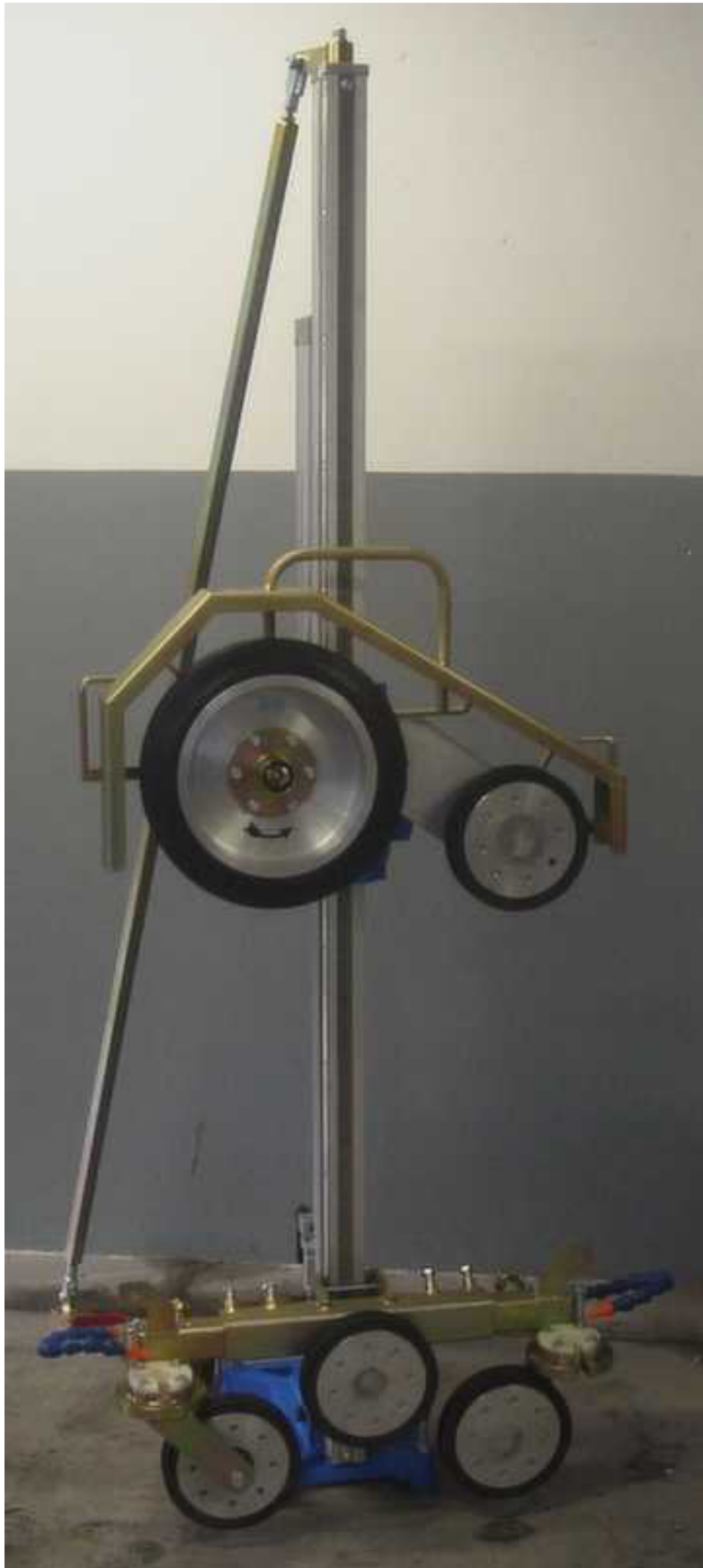

Operator's Manual storage wire saw

Definition

Picture:



- The wire saw Profi Wire is designed to structures within the steel, concrete, brick construction as walls within the high and low buildings to demolish. Depending on the application and applied wire can be used wet or dry cut. Use outside this scope money if not standard and require clarification with the producer.
- The responsible operator must be aware of the hazards and safety. Also with respect to other persons.
- The wire saw is designed for maximum cut of 2 mtr. The maximum distance between the drive roller to the machine and exit point of the wire must not exceed 3 meters.
- The operation is restricted to specially trained operators. These must be fully aware of the contents of this manual.
- With national regulations and laws as well as the operating instructions and safety instructions of the used accessories (eg diamond wire, fasteners, lifting equipment, compressors, hydraulic unit, etc.) should be taken into account.
- Do not operate saw for loose or in the hand parts saws.
- It is forbidden to the wire saw and associated components for applications other than wire saws to use. Eg if transport or hoist use.

Legend:

1. drive Unit
2. footplate
3. tripod
4. Wire Protection (2 pieces)
5. Output zwenkrollen (2 pieces)
6. Reinforcement (attraction)
7. pneumatic cylinder

Contents

Contents

- 1) General Safety
- 2) Technical specifications, delivery and technical preferences
- 3) Safety
- 8) I Commissioning
- 9) Commissioning II
- 10) Application example (single store)
- 11) Application example (double storage)
- 12) Application example (change position)
- 13) Application Example (Preparation by sawing)
- 14) Application example (cut overall turnover)
- 15) Maintenance and Repair

Safety Precautions

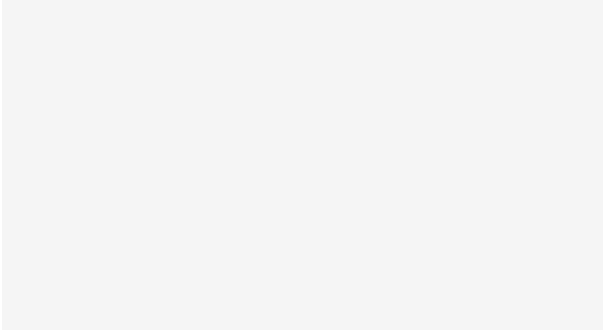

Gloves Required



Safety Glasses
Required



Helmet Required



This icon indicates the possibility of a dangerous situation, which may lead to injury and / or damage.



Safety Boots Required



Mask Required



See Manual



Operator's Manual storage wire saw

Professional Wire Storage wire saw

The Profi-Wire is a storage wire saw, for small and medium cuts of up to 3 m, developed and perfected by wire sawing experts. He has a wire storage of about 8.3 m. With a maximum stroke of the machine can be set to 6.3 m without the wire to shorten. The thread tension is kept constant by the pneumatic cylinder. The drive is done by a hydraulic motor (generator required 32-40 liters per minute, min: 140 bar, not less than 11 kW)

With only 2 stroke anchors the Professional Wire quickly assembled and supplied by strengthening the wire has a low vibration quiet running. The 86-pound saw is in little acts to disassemble into 3 parts, each weighing no more than 32 kg. The crank on the drive wheel ensures that there is a significant time savings when finalizing the concrete edges. There is an optimal water supply at both castor wheels. Through slots in the rollers can also be mounted an endless loop. Due to the conduction in the column, there is a smooth movement during operation. The Profi-Wire features laterally sliding output casters, so that when the 180 rotation of the wheels no deadlock occurs, the wire has no contact with the role and starts to walk. There are also cuts may just above the floor and about 1 meter from the wall using free to place casters.

Technical data:

Weight: Saw: 86 kg (subdivided into 32 kg and 26.28)
Compressor with control: 33 kg
Dimensions: L: 2100 mm W: 750 mm (variable) D: 700mm
Stroke: 1400 mm
Storage: single or double
Compressor: 10 Bar, 20 liter tank, 230 V, 50 Hz
Drive wheel: 360 mm diameter
Wheels: 200 mm diameter double ball bearing with grease nipple

Hydraulic motor: 32-40 L / min, min 140 bar, min 11.5 kW = 21 to 26.5 m / sec
The maximum pressure of 200 bar must not be exceeded.

Wire Storage: 8,3 mtr (if the cut is done in the machine)

Wire intake: 6,3 m (without the wire to shorten)

Example: Possible cut with wire of 8.3 m length

1.0 x 2.5 or 3.0 x 0.5 or 1.75 x 1.75 mtr
(Minor technical changes reserved)

Scope of delivery:

- 1x Professional Wire storage wire saw
- 1x Support with base to anchor
- 1x Compressor
- 1x Pneumatic remote
- 1x Pneumatic hose package (3 tubes)
- 1x Crank for drive wheel
- 1x Hydraulic motor
- 2x wire shield
- 2x Water supply with crane
- 2x Wrench

Safety Precautions

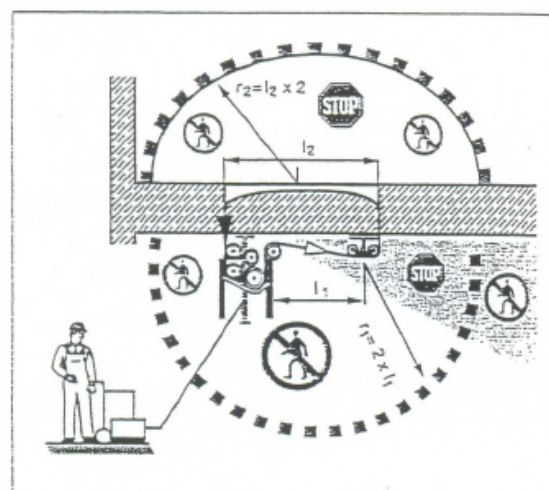
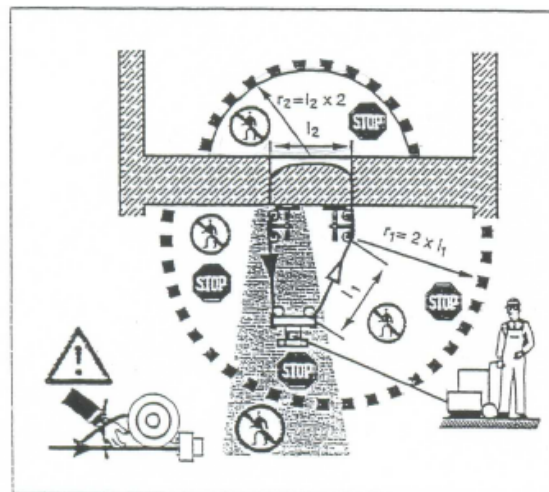

Protection of the Stage

* The work area must be shielded so that operators, third parties and installations not by ejected parts (pebbles, wire, sludge, etc.) hit, injured or damaged. Protect also not directly visible hinterland area.

* The safety zone during operation should NEVER be entered. This is an area of at least double the radius of the free length of the wire at a possible fracture. Both the front and rear. The operator is responsible for the protection and access control.

* Ensure that the free length between the drive and building object as short as possible. NEVER work without going on in - and outlet of the thread guides mounted! So that in the case of a wire breakage of the wire is forced through the hollow shaft of the wheel to go compulsion, wherein the free length is shortened drastically. Free long wire lengths can suffer a broken wire to wire a whipping.

* Make sure that none of the Stage during assembly and the work being setup. Falling parts or tools can cause serious injuries.

Preparation

* Saw Work affect the static electricity. Drill - and cutting work should be approved for implementation by the performer.

* Ensure, in consultation with the contractor that there are no gas - water - electricity, - or other lines are within the surrounding area that are close to the cut and who can be damaged by falling parts should be separately protected and may be made inoperable.

* Make sure the cooling water flowing checked or sucked. Uncontrolled runoff or spray water can cause damage and accidents. Also remember that even

water can drain by hidden cavities can flow eg in walls.

* Note the environment influence. Use the wire saw is not in potentially unsafe areas or near flammable materials, liquids or gases. Rains spark or electrostatic discharge may cause fire or explosion.

* Do not cut materials when cutting materials or vapors which are explosive or bad for health.

* Do not cut flammable aluminum or magnesium alloys.

Safety Precautions

Security components and saw sludge storage

* To prevent damage, and terminals of the wire to prevent debris must be freed using wedges and / or struts against uncontrolled movements be secured.

* Make sure both people and equipment are not endangered as a result of the release of debris. Ensure by appropriate measures (struts etc) that the fragments remain in place after the last cut is finished.

* Moving and transporting the often many tons of heavy debris, should only be done by authorized personnel using approved lifting equipment.

* Make sure you never hoisted load.

* The resulting hole or opening shall be deposited safely and easily visible to prevent persons herein may fall.

* In terms of the environment, the disposal of saw slurry in water or sewer without proper pretreatment problematic. Make sure you're informed by the local authorities for the applicable regulations. We recommend the following treatments:

- Collection of waste water in a reservoir (industrial vacuum cleaner)
- Let the water stand until the sludge is

beaten down and make sure that the hard part is brought to a landfill. (With flow coolant, this process faster)

- Neutralize the remaining water by mixing with neutralizing agent or dilute it with water.

Safety in operation

- * Check the wire saw and its components as well as the wire and connection are used for optimal use. Ensure that damage and improper operation for setup solved by authorized personnel.

- * Set the console as far as possible from the danger zone and make sure you close the control panel continues during operation.

- * There should only work if the wire saw and the wheels securely on a solid substrate are attached. A fall or tip-over section can cause serious injury or damage may result.

- * Connect the power and compressed air only when the wire saw is fully installed.

- * Take the wire saw into operation only if the thread according to the rules in the in - and out of the kerf is protected and if the wire through the hollow shaft of the caster runs.

- * Entering the safety zone (eg for readjusting the wheels or water) is allowed only if the hydraulic unit is switched off and the drive wheel is stationary.

- * Hold while cutting the allowable drive parameter into the holes (hydraulic pressure) as well as the recommended cutting speed and pressure of the air cylinder.

- * Use only wires that are suitable for operation with a minimum cutting speed of 30 m / s, and which have a space between the coated beads.

- * The use of high quality wire saws, draadverbinders and press tools, the number of wire breaks drastically reduced.

- * When the dry cutting at the operating temperature of the wire is not exceeded (possibly intermediate to cool).

- * The wire can get hot, so never take hold without gloves!

- * Wear a dust mask and dry cutting, always make sure that the health of others is not affected by inhaling the dust.

- * Use for attaching the wheels and wire saw as the anchoring of components only sufficiently dimensioned mounting hardware (anchors, screws, etc.)

Safety Precautions

- * Use only accessories that are recommended in this manual. The use of other parts can lead to injury or damage.

- * When using ladders eg for mounting the wheels on the wall, make sure that the ladder meets the safety is not damaged and that the ladder is stable.

- * The operator must ensure that no persons are within the safety zone during operation of the wire saw. This includes not directly visible region eg at the rear of the saw cut. If it is necessary should be put down large fences or guard must be put down.

- * Always be observant. View the saw will cut the cooling as well as the environment of the area. Do not operate the saw wire if you cannot concentrate.

Protect electrical shock

- * Before each use, the power cord, plug, compressor and hydraulic unit for soundness. Use the equipment if there is any damage, if the equipment is not complete or the controls will not operate

optimally.

* Connect the electrical, hydraulic and compressor unit only to power sources that are adequately encrypted. Test for the commissioning of all works.

* Make sure that the mains voltage corresponds to the requirements on the nameplate of the machine.

* Ensure that electrical cables and connectors are not wet. Closes off the power strips with associated seals, as they are not used.

* When disconnecting the power supply never pull on the cable, always pull the plug. Protect electrical cables from sharp edges, pinched, heat and oil.

* Use of extension cords only use extension cords with sufficient capacity to cope. Never work with coiled cord. Otherwise, this may result in loss of power to the machine or

cord may overheat. Replace damaged extension cords.

* Disconnect the power connection when cleaned, there are maintenance or for a long time not worked.

Safety Guidelines
transport of the wire saw

* Secure the wire saw and its components during transport from accidental slipping.

* Avoid in a flexed posture when wearing heavy parts. Try to keep your back straight.

* Note that a mounted standing, not confirmed tipping. Therefore, put the unit with the wheels forward on a flat and stable surface.

* Use the provided handles during transport. Keep the grips clean and free of grease.

Safety Precautions

Failure to follow the warnings and safety precautions may result in injury and material damage!

*Crane transport - the saw may only approved lifting done in the space provided. Make sure to transport all detachable parts are properly tightened, the drive is locked and that the limit switch is mounted. Make sure you never hoisted load.

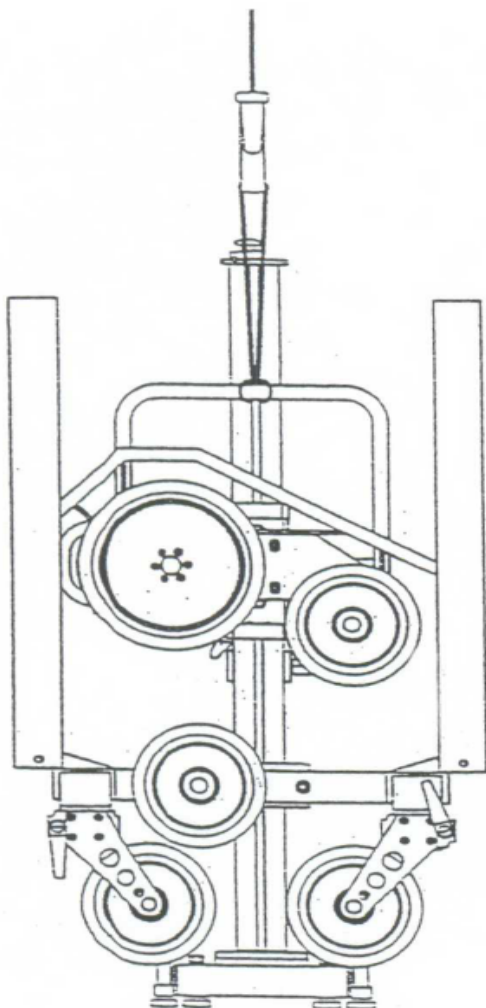

* Do not allow children or other persons in the workplace. Make sure that no wire saw, diamond wire cables and touching.

* Always wear the designated work wear. Work gloves, safety shoes, safety glasses and helmet. Do not wear loose clothing and jewelry. Wear long hair in a hairnet. Wearing hearing protection is recommended.

General Safety Requirements

* Use the wire saw only if you are familiar with the contents of this manual.

* Keep the operating manual with the machine and give it the next trained operator.

* Mount the wire saw in a closed and dry place out of reach of children.

* Careful cleaning and maintenance according to the regulations are essential for safe and trouble-free operation.

* Do not leave tool down. Check for the switching on the drive that any and all tools are removed.

* Keep the workplace clean and tidy and well lit. Disorder and poor lighting increase the risk of accidents.

Safety Precautions

Make sure that there are enough supports and anchors the debris to jamming of the wire or the endangering of equipment or persons.

Work before and after termination of the saw

- * Set for cutting parts of the fixed or the free part of the thread can be completely absorbed on the mounted wheels.
- * Let the speed of the wire decrease just before the part is cut (depending on the hydraulic unit) and turn the drive off when the parts are cut.
- * Check the hydraulic unit and disconnect the air cylinder. Then switch on the pneumatic valve in the neutral medium and then lock the sliding housing.
- * Disconnect to convert to the next cut both the hydraulic lines when the pneumatic pipes.

Progress in lifting end adjustments
(With maximum storage magnification)

If the maximum lift point is reached, switch off the hydraulic power unit (motor and oil flow) and lock the sliding housing. Then put the pneumatic valve in the neutral medium. Then the return valve and the cylinder rod clamp and the

cylinder are made by hand be pressed back.

The length of the used hydraulic lines should be at least long enough to allow the unit outside the danger zone member.

Loosen the locking cylinder of the progress and the clamping of the cylinder rod only go if you are sure that there is no pressure on the progression cylinder.

Saw Progress check

For example, enters the danger zone for the adjustment of the water nozzles, adjustment of the guide wheels, adjusting the progress cylinder, mounting of the clamping anchors, etc. only to a stationary drive, power unit, and turned off the pneumatic valve is in the neutral center position.

Stay during cutting outside the danger zone and near the power switch of the unit in case of a dangerous situation the

drive immediately to turn.

* Ensure that the saw wire has sufficient cooling and adjust the water so that there is enough water in the cut can come.

* Note quiet swishing and not during the sawing wire. If the thread starts to sway, the guide wheels or the adjusted pressure progression.

* Ensure that the hydraulic pressure between 80 and 120 bar. If the pressure falls away, it may be by increasing the pneumatic pressure progress again be increased.

Check for the turn of the hydraulic unit, all hoses are correctly connected and locked. A return line is not connected can damage the hydraulic motor suffer.

Set to turn on the wire saw firmly, that nobody is within the danger zone and also without your permission can get! Turn off the main drive immediately if the thread is not in motion. Set the switch on the hydraulic unit in operation and turn the valve on the cylinder progress in the neutral medium.

Commissioning I

Before setup, the operating instructions for the operator fully read and understood. In the operating manual is a movie (approx. 8 min) that can be played on any computer and must in any case for setup can be viewed by the operator (possibly multiple times).

Step 1)

Draw the desired cut off

Step 2)

The first anchor hole is so marked that the wire to the output place freely and without sharp bends in the bore of the threaded bushing can walk.

Step 3)

The anchor base with fixed column is put.

Step 4)

When the guide wheels.

Step 5)

Aligning the diamond wire with the marked cut.

Step 6)

Shift the drive unit (including pneumatic sensors for progress)

Step 7)

Locking of the drive unit (black knob 90 °)

Step 8)

Connecting the 3 compressed air hoses to the cylinder, the compressor and the remote Remote control in the neutral medium.

Compressor to convert (maximum pressure at the compressor 10 bar)

Step 9)

Diamond Wire impose.

Diamond Wire Screw.

Diamond Wire with hydraulic press sound (according to supplier instructions thread)

Step 10)

Locking of the drive unit outlet (black knob 90 °)

Step 11)

Diamond wire tension with light pressure on the remote switch to turn ZUG. (The remote control has 3 positions, middle is neutral, the other two modes are forms (round) and zurück (back).

Step 12)

The wire is now fixed on the saw. The limit switch is now on the cylinder rod is pushed upwards (loosen clamp and slide up to the stop of the cylinder). The limit switch is again tightened.

Commissioning II

Step 13)

Creation of the transverse support and anchor it at about 120 ° turning range. (The saw should always be put with 2 anchors. A, at the foot and the transverse support.

Step 14)

Two side guards with pins and clamps.

Step 15)

90 ° angles to the cutting parts with an angle grinder or chisel with a complete and so take off the sharp edges.

Step 16)

The 2 hydraulic hoses connect (1x supply, 1x drain).

Step 17)

The crank on the drive flange and with the hand 2 to 3 by the wire lengths to run wire. Then take off the handle and safe storage.

Step 18)

Water Sprinklers connect and focus on the cut (2 pieces)

Step 19)

All persons out of danger.

Step 20)

Starting from the saw unit (32-40 L / min min 11.5 kW, max 200 bar)

Optimal: 40 L / min Stage 80-120 (140) bar

If the maximum speed is reached, the pressure increase on the remote:

With some storage: 2-3 bar

For double storage: 4-5 bar

Step 21)

In the further course can cut the output casters need to be adjusted laterally (see application examples).

Application example

Some storage

So they start a cut:

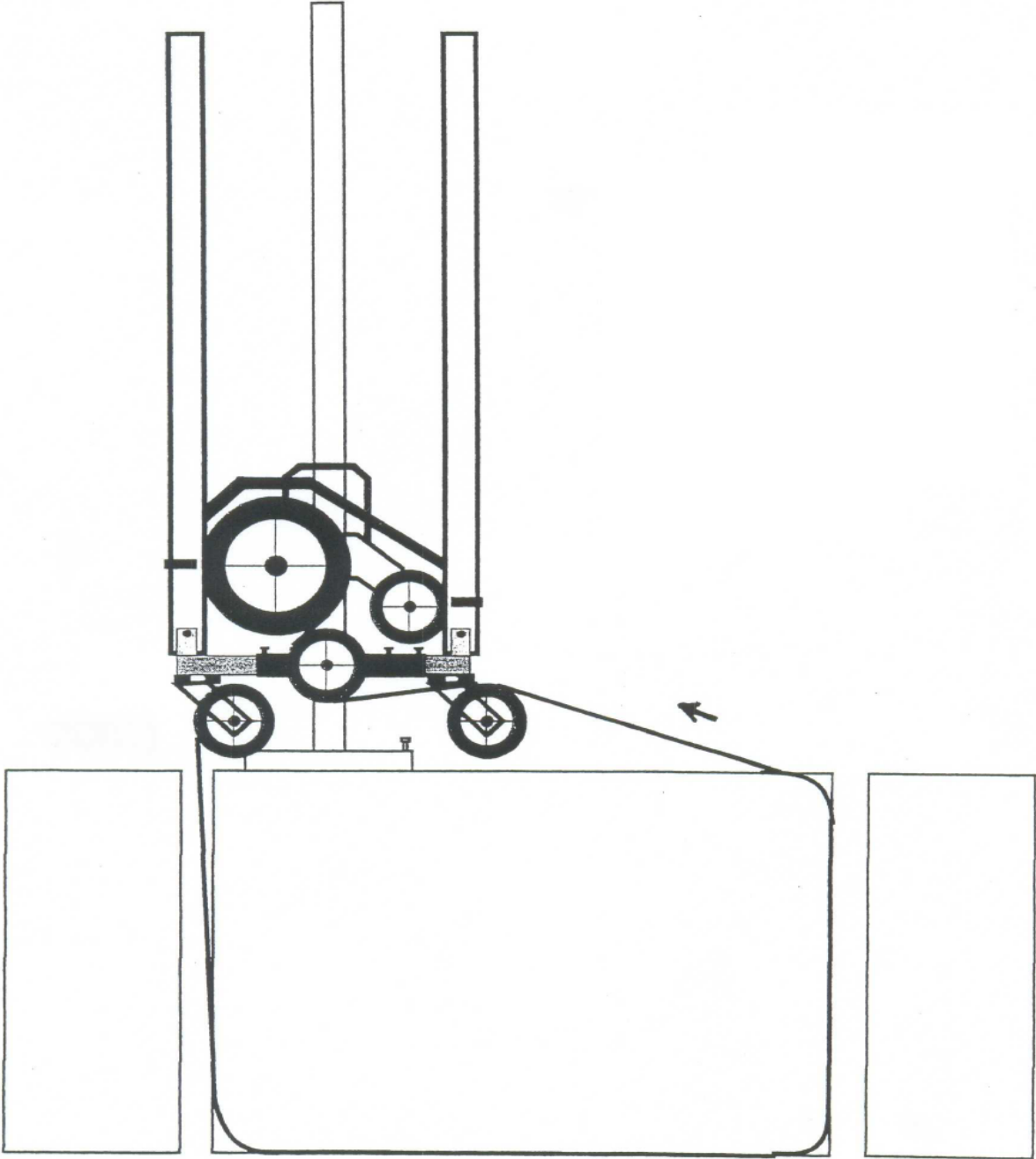

Operator's Manual storage wire saw

Application example dual storage

To start it a cut as the wire is longer:

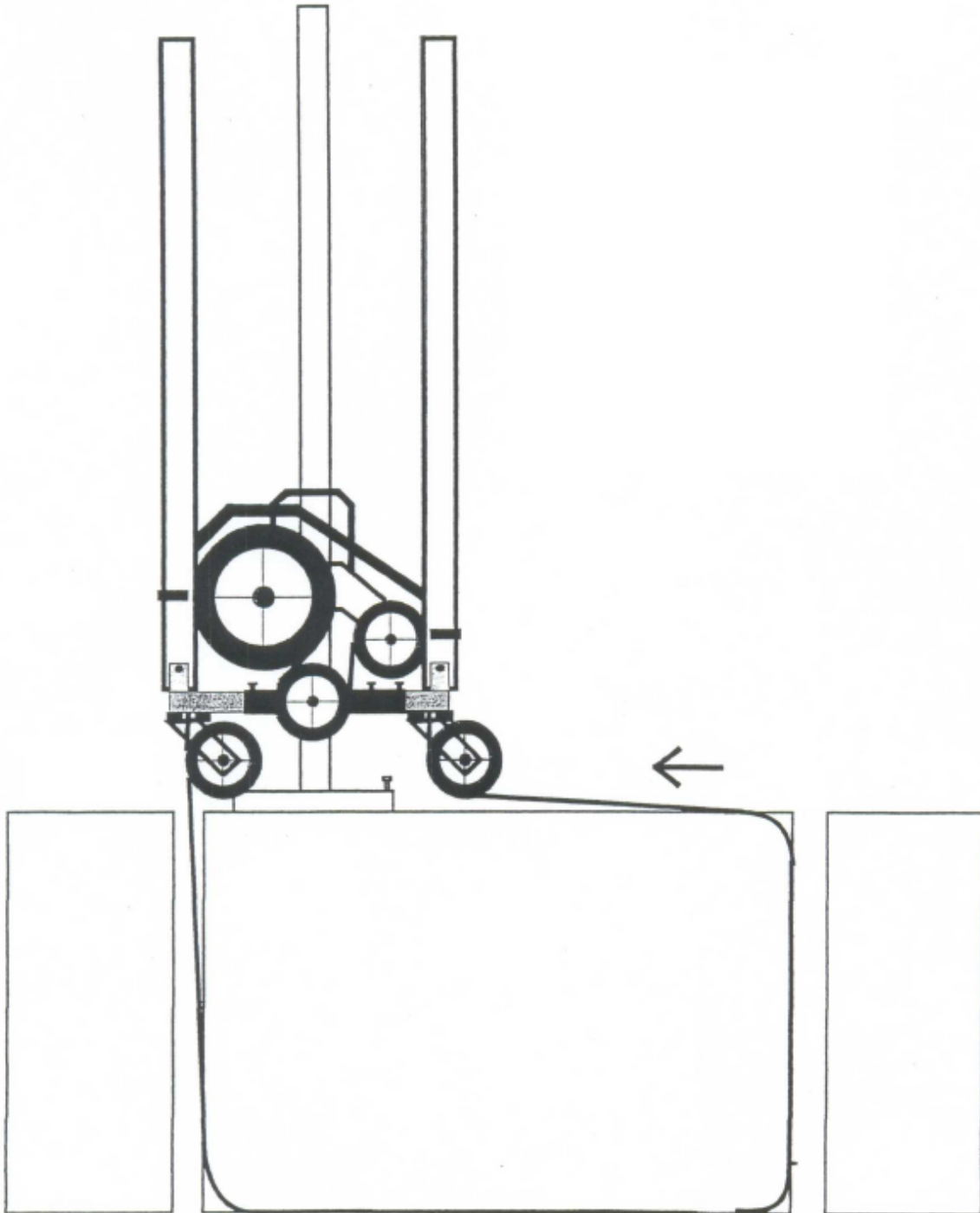

Application example dual storage

In this position would be starting right wheel to the right should be extended and rotated 180 ° to be an optimum cutting position to obtain.

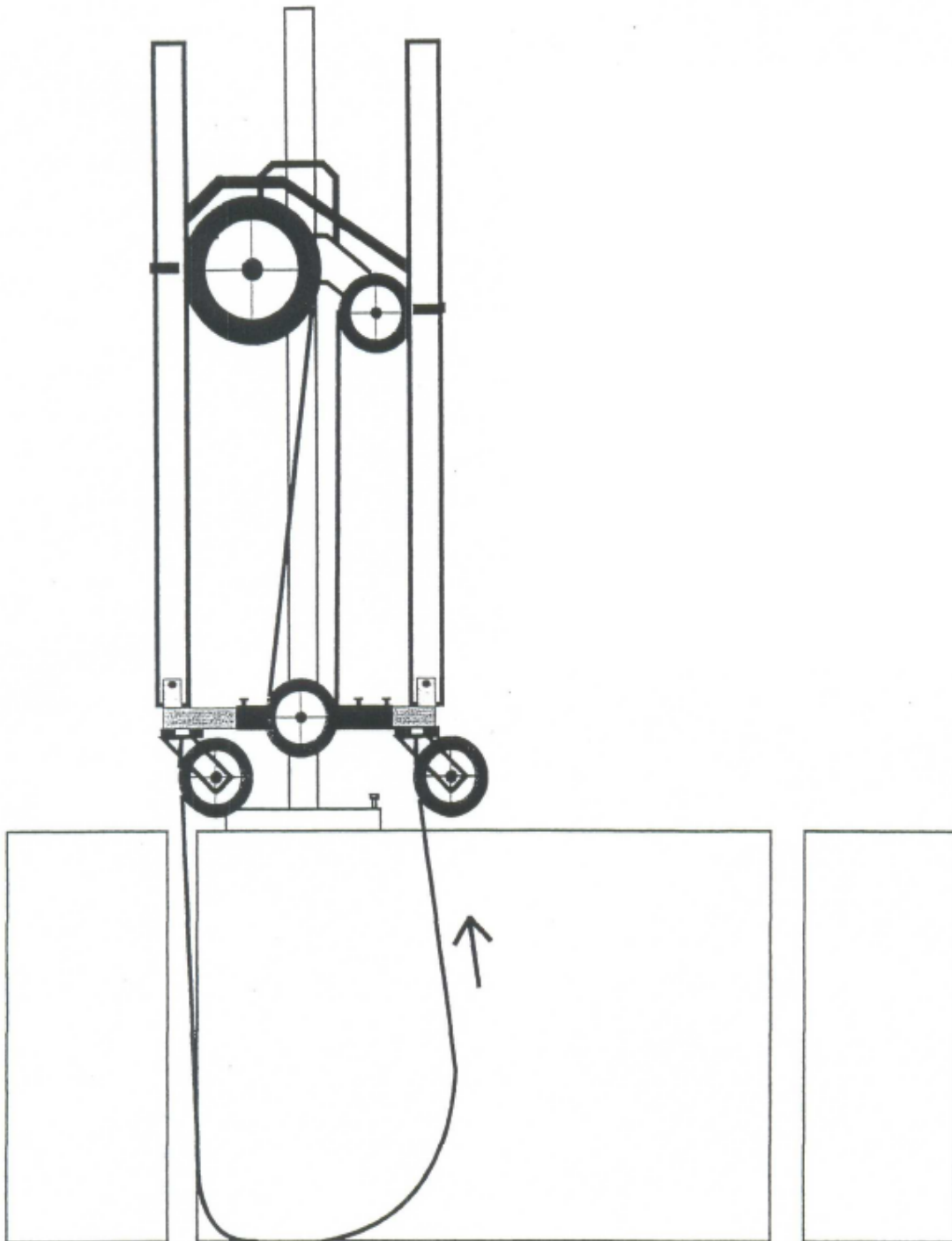

Application example dual storage

In this position, it would be left to the right wheel output must be pushed in order to obtain an optimal cutting position and to hold the cut end.

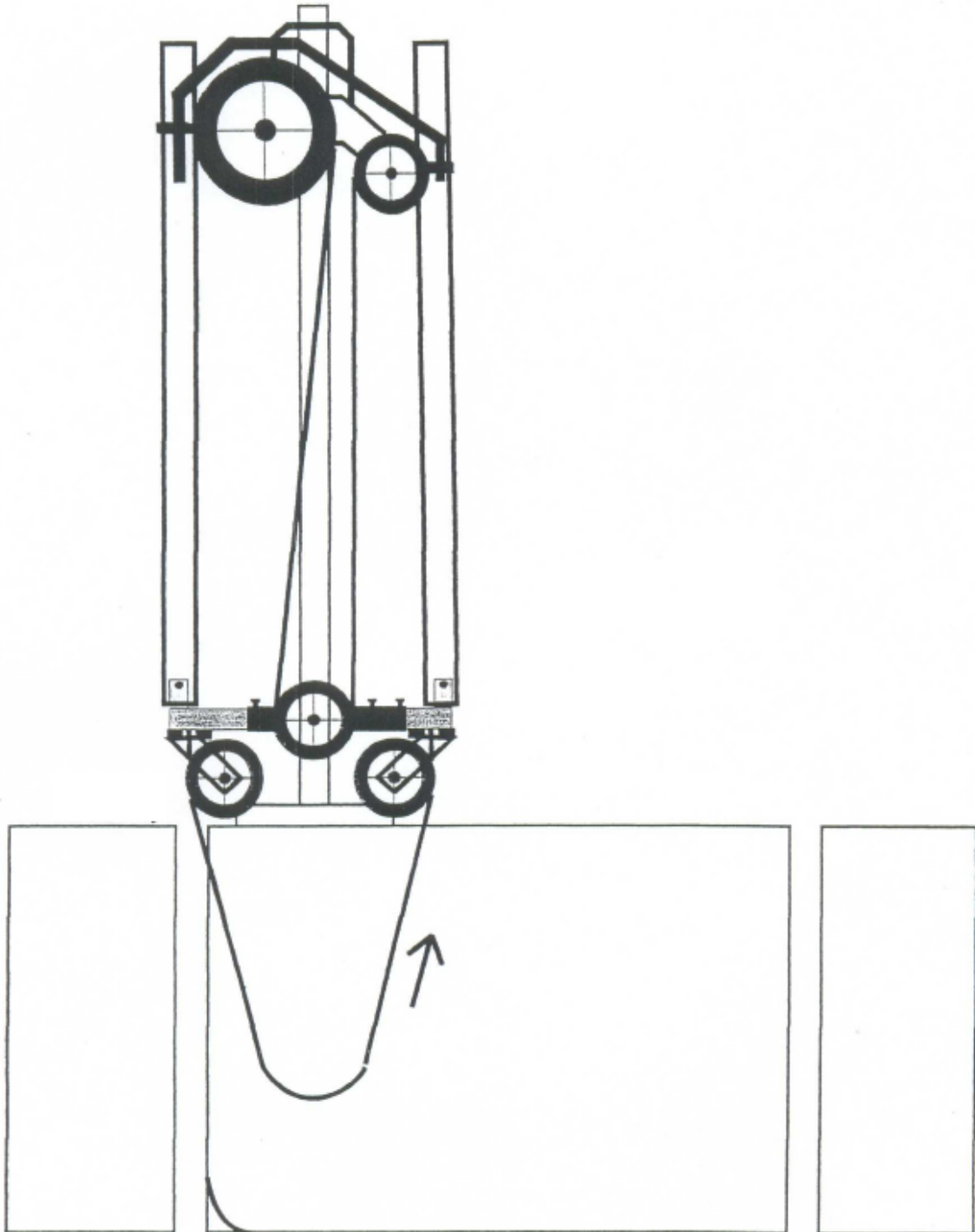

Application example

Schematic representation how the saw should proceed.

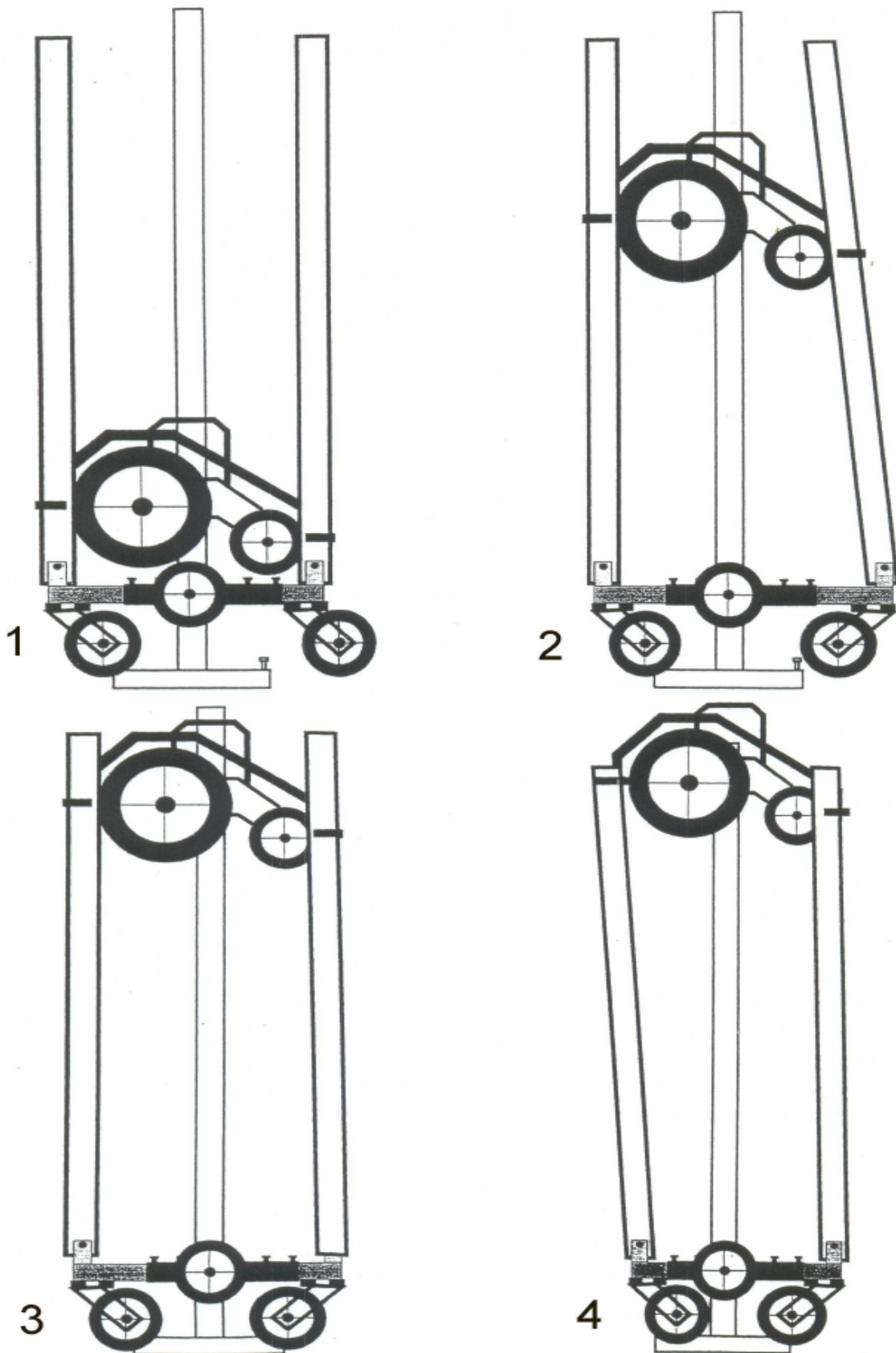

Maintenance and repair

- * Regular proper cleaning and maintenance of the system ensures smooth running of moving parts and protect the system from damage by pollution.
- * We recommend a coarse cleaning of the wire saw, as well as the support wheel after every cut to. Please ensure in particular treads, the rack and all moving parts and controls.
- * Clean the entire system right at the end of each day with water and a brush too hard except for the electrical installation, the compressor and the hydraulic unit. Plan to clean in your work.
- * Check after cleaning the smooth running of moving parts, the proper functioning and damage. Take care that the drive unit without load by up to 2.5 bar pressure easily throughout the lift can move. Damaged or mal-functioning parts should be replaced before use, to costly subsequent damage or injury.
- * Spraying machine with concrete separating agent reduces the adhesion of dirt and makes the next cleaning.
- * Empty at least once a month the service unit to the control panel as well as the pressure vessel of the compressor.