



smart
architectural aluminium

Smart Wall

Smart Wall is a thermal shop front screen and door system suitable for all types of ground floor treatment where enhanced thermal performance is required. The system is ideal for use in schools, colleges and other educational buildings.

- U Value 1.8 W/m²K for Smart Wall Doors
- LPS 1175 Level 2; Enhanced Security Performance
- ENV 1627 Level 3; Enhanced Security Performance
- BS6375 Weather rated, anti-finger trap doors

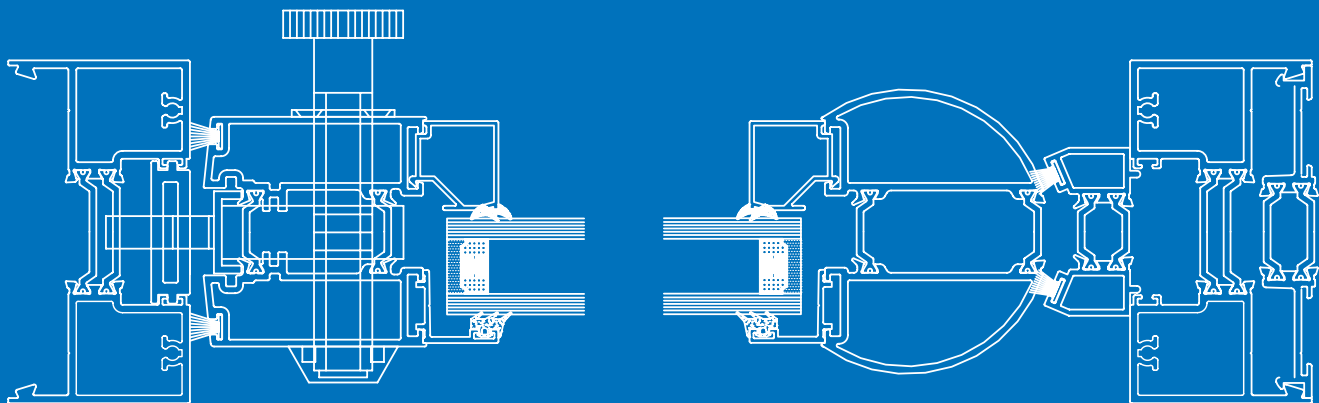

Smart Wall

Smart Wall has recently been successfully tested to LPS 1175 level 2 and BS ENV 1627 Level 3 for enhanced security performance making the door one of the best performing fully thermally broken screen and entrance doors available in the UK. Screen work is either beaded or pocket glazed Smart Wall doors are weather rated to BS6375 and are available with anti-finger trap door sections and drainable low thresholds. All profiles feature polyamide barriers to maximise thermal performance and can be internally or externally glazed. Unlike non-thermal alternatives, Smart Wall is available in dual colour from an extensive range of standard and non-standard finishes. Smart Wall complies with the latest requirements of Document L for thermal transmittance.

Features

- Swing, hinged & automatic commercial entrance doors and ground floor treatment

Application

- Thermally Broken, Heavy Duty Doors & Screens
- 30kg Dynamic Impact Test
- 6kN Static Test Load
- Security Grade 6 Locking Mechanism
- Locking Bolt withstands 10kN Side Load
- Polyamide thermal break
- Achieves U value 1.8W/m²K
- Internally Beaded Sash
- Anti-Finger Trap
- Thermally Broken Low Threshold

Finish

Polyester powder coat to marine quality as standard

Technical Performance

U Value	1.8 W/m ² K for Smart Wall Doors	
	<i>Rebated Door</i>	<i>Screen Work</i>
Air	Class 2, 300pa	Class 4, 600pa
Water	Class 7a, 150pa	Class 9a, 600pa
Wind	Class A5, 2000pa	Class A4, 1600pa
Doc L 2010	Yes	
Dimensions		
Frame Width	53mm	
Frame Depth	100mm	
Max sash size	2500mm	
Max sash width	1150mm	
Max sash weight	80kg	
Glass	24-32mm double or triple glazed sealed units	

Test Certification

LPS 1175 Level 2 Enhanced Security Performance
 ENV 1627 Level 3 Enhanced Security Performance
 BS 6375 Weather Performance

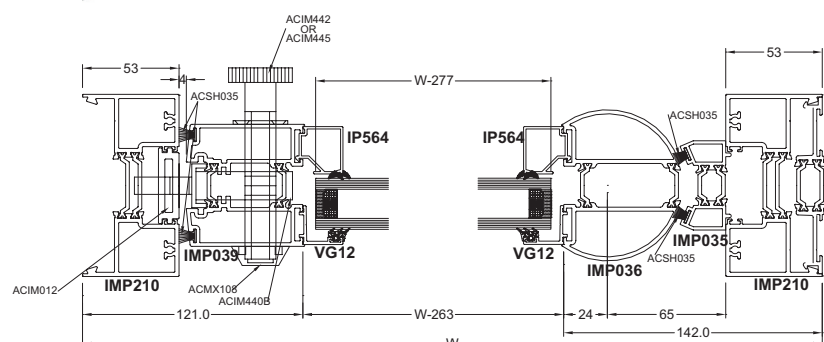

smart
 architectural aluminium

Smart Systems Limited Arnolds Way, Yatton, North Somerset BS49 4QN. UK

Tel +44 (0)1934 876100 Fax +44 (0)1934 835169 sales@smartsystems.co.uk www.smartsystems.co.uk

Images and drawings are for illustrative purposes only and are not binding in specification, colour or detail.