

Old **REACTOR™**

311300E rev.j

Hydraulic, Heated, Plural Component Proportioner
For spraying polyurethane foam and polyurea coatings.
Not for use in explosive atmospheres.



Important Safety Instructions

Read all warnings and instructions in this manual.
Save these instructions.

See page 3 for model information, including maximum working pressure.

Model H-25 with 8 kW Heater

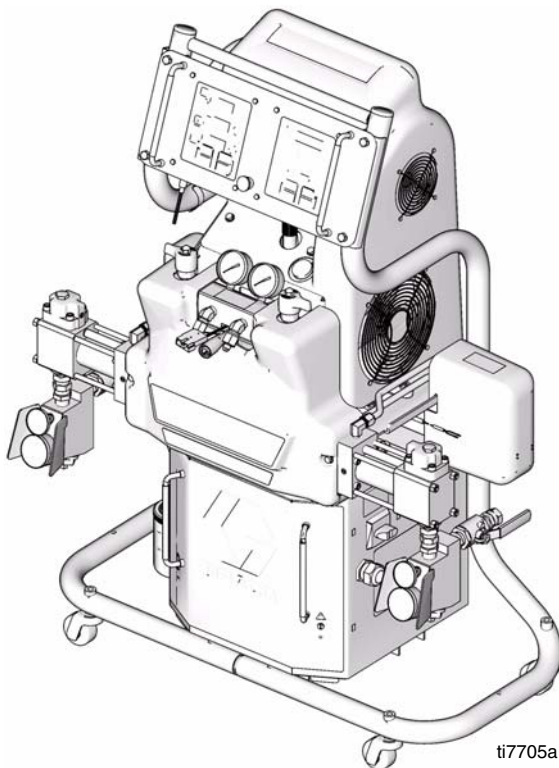

Model H-XP2 with 15.3 kW Heater

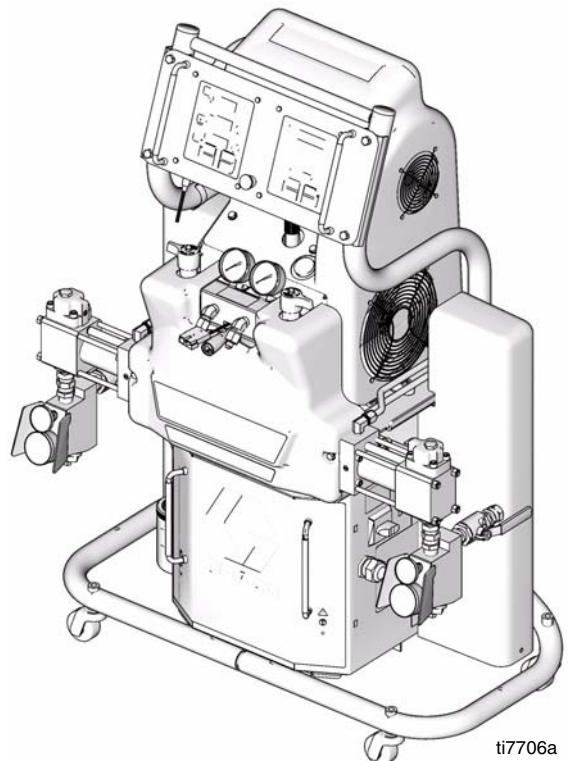

GRACO | GUSMER



Contents

Models	3	Repair	24
Supplied Manuals	4	Pressure Relief Procedure	24
Related Manuals	4	Flushing	25
Warnings	5	Proportioning Pumps	26
Temperature Control Diagnostic Codes	7	Circuit Breaker Module	27
E01: High fluid temperature	7	Electric Motor	28
E02: High hose current	8	Motor Control Board	29
E03: No hose current	8	Transducers	31
E04: Fluid Temperature Sensor (FTS) or thermocouple A or B not connected	9	Electric Fan	31
E05: Board overtemperature	9	Temperature Control Board	32
Motor Control Diagnostic Codes	10	Primary Heaters	35
Alarms	10	Heated Hose	39
Warnings	10	Fluid Temperature Sensor (FTS)	39
E21: No component A transducer	11	Transformer	41
E22: No component B transducer	11	Display Module	45
E23: High fluid pressure	11	Inlet Fluid Strainer Screen	47
E24: Pressure imbalance	11	Pump Lubrication System	47
E27: High motor temperature	13	Change Hydraulic Fluid and Filter	48
E30: Momentary loss of communication	13	Parts	50
E31: Pumpline reversing switch failure/high cycle rate	13	Parts Used on All Models	57
E99: Loss of communication	13	Parts that Vary by Model	60
Troubleshooting	14	253189 8.0 kW Dual Zone Heater	63
Reactor Electronics	14	253911 7.65 kW Single Zone Heater (2 per machine)	64
Primary Heaters (A and B)	16	295027 Hydraulic Cylinder	65
Hose Heat System	18	245974 Display	66
Hydraulic Drive System	20	245979 Temperature Control	67
Proportioning System	21	246154 Fluid Manifold	68
		Circuit Breaker Modules	69
		Technical Data	72
		Graco Standard Warranty	74
		Graco Information	74

Models

H-25 SERIES

Part No., Series	Full Load Peak Amps*	Voltage (phase)	System Watts**	Primary Heater Watts	Flow lb/min (kg/min) at 35 cpm	Output per Cycle (A+B) gal. (liter)	Pressure Ratio	Maximum Fluid Working Pressure psi (MPa, bar)
253200, A	63	230V (1)	14,700	8000	22 (10)	0.063 (0.24)	1.91:1	2000 (13.8, 138)
253201, A	40	230V (3)	14,700	8000	22 (10)	0.063 (0.24)	1.91:1	2000 (13.8, 138)
253202, A	29	380V (3)	14,700	8000	22 (10)	0.063 (0.24)	1.91:1	2000 (13.8, 138)
253206, A	95	230V (1)	22,000	15,300	22 (10)	0.063 (0.24)	1.91:1	2000 (13.8, 138)
253207, A	58	230V (3)	22,000	15,300	22 (10)	0.063 (0.24)	1.91:1	2000 (13.8, 138)
253208, A	35	380V (3)	22,000	15,300	22 (10)	0.063 (0.24)	1.91:1	2000 (13.8, 138)
253300, A	69	230V (1)	15,960	8000	22 (10)	0.063 (0.24)	1.91:1	2000 (13.8, 138)
253301, A	45	230V (3)	15,960	8000	22 (10)	0.063 (0.24)	1.91:1	2000 (13.8, 138)
253302, A	35	380V (3)	15,960	8000	22 (10)	0.063 (0.24)	1.91:1	2000 (13.8, 138)
253306, A	100	230V (1)	23,260	15,300	22 (10)	0.063 (0.24)	1.91:1	2000 (13.8, 138)
253307, A	58	230V (3)	23,260	15,300	22 (10)	0.063 (0.24)	1.91:1	2000 (13.8, 138)
253308, A	35	380V (3)	23,260	15,300	22 (10)	0.063 (0.24)	1.91:1	2000 (13.8, 138)

H-XP2 SERIES

Part No., Series	Full Load Peak Amps*	Voltage (phase)	System Watts**	Primary Heater Watts	Flow gpm (lpm) at 35 cpm	Output per Cycle (A+B) gal. (liter)	Pressure Ratio	Maximum Fluid Working Pressure psi (MPa, bar)
253203, A	95	230V (1)	22,000	15,300	1.5 (5.7)	0.042 (0.16)	2.79:1	3500 (24.1, 241)
253204, A	58	230V (3)	22,000	15,300	1.5 (5.7)	0.042 (0.16)	2.79:1	3500 (24.1, 241)
253205, A	35	380V (3)	22,000	15,300	1.5 (5.7)	0.042 (0.16)	2.79:1	3500 (24.1, 241)
253303, A	100	230V (1)	23,260	15,300	1.5 (5.7)	0.042 (0.16)	2.79:1	3500 (24.1, 241)
253304, A	58	230V (3)	23,260	15,300	1.5 (5.7)	0.042 (0.16)	2.79:1	3500 (24.1, 241)
253305, A	35	380V (3)	23,260	15,300	1.5 (5.7)	0.042 (0.16)	2.79:1	3500 (24.1, 241)

* Full load amps with all devices operating at maximum capabilities. Fuse requirements at various flow rates and mix chamber sizes may be less.

** Total system watts, based on maximum hose length for each unit:

- Part Nos. 253200 through 253208, 210 ft (64 m) maximum heated hose length, including whip hose.
- Part Nos. 253300 through 253308, 310 ft (94.6 m) maximum heated hose length, including whip hose.

Supplied Manuals

The following manuals are shipped with the Reactor™ Proportioner. Refer to these manuals for detailed equipment information.

Order Part No. 15B535 for a compact disk of Reactor manuals translated in several languages.

Manuals are also available at www.graco.com.

Reactor Hydraulic Proportioner	
Part No.	Description
311299	Reactor Hydraulic Proportioner, Operation Manual (English)
Reactor Electrical Diagrams	
Part No.	Description
311508	Electrical Diagrams (English)
Proportioning Pump	
Part No.	Description
311391	Proportioning Pump Repair-Parts Manual (English)

Related Manuals

The following manuals are for accessories used with the Reactor™.

Order Part No. 15B535 for a compact disk of Reactor manuals translated in several languages.





Order Part No. 15B381 for a compact disk of Fusion manual translated in several languages.







Feed Pump Kits	
Part No.	Description
309815	Instruction-Parts Manual (English)
Air Supply Kit	
Part No.	Description
309827	Instruction-Parts Manual (English) for Feed Pump Air Supply Kit
Circulation and Return Tube Kits	
Part No.	Description
309852	Instruction-Parts Manual (English)
Heated Hose	
Part No.	Description
309572	Instruction-Parts Manual (English)

Fusion Air Purge Spray Gun	
Part No.	Description
309550	Instruction-Parts Manual (English)
Fusion Mechanical Purge Spray Gun	
Part No.	Description
309856	Instruction-Parts Manual (English)
Circulation Kit	
Part No.	Description
309818	Instruction-Parts Manual (English)
Data Reporting Kit	
Part No.	Description
309867	Instruction-Parts Manual (English)
Transformer Repair Kit	
Part No.	Description
309930	Instruction-Parts Manual (English)
Rupture Disk Assembly Kit	
Part No.	Description
309969	Instruction-Parts Manual (English)
Proportioning Pump Repair Kits	
Part No.	Description
312071	Instruction-Parts Manual (English)

Warnings

The following warnings are for the setup, use, grounding, maintenance, and repair of this equipment. The exclamation point symbol alerts you to a general warning and the hazard symbols refer to procedure-specific risks. Refer back to these Warnings. Additional, product-specific warnings may be found throughout the body of this manual where applicable.

 WARNING	
	<p>ELECTRIC SHOCK HAZARD</p> <p>Improper grounding, setup, or usage of the system can cause electric shock.</p> <ul style="list-style-type: none"> • Turn off and disconnect power cord before servicing equipment. • Use only grounded electrical outlets. • Use only 3-wire extension cords. • Ensure ground prongs are intact on sprayer and extension cords. • Do not expose to rain. Store indoors.
	<p>TOXIC FLUID OR FUMES HAZARD</p> <p>Toxic fluids or fumes can cause serious injury or death if splashed in the eyes or on skin, inhaled, or swallowed.</p> <ul style="list-style-type: none"> • Read MSDS's to know the specific hazards of the fluids you are using. • Store hazardous fluid in approved containers, and dispose of it according to applicable guidelines.
	<p>PERSONAL PROTECTIVE EQUIPMENT</p> <p>You must wear appropriate protective equipment when operating, servicing, or when in the operating area of the equipment to help protect you from serious injury, including eye injury, inhalation of toxic fumes, burns, and hearing loss. This equipment includes but is not limited to:</p> <ul style="list-style-type: none"> • Protective eyewear • Clothing and respirator as recommended by the fluid and solvent manufacturer • Gloves • Hearing protection
	<p>SKIN INJECTION HAZARD</p> <p>High-pressure fluid from gun, hose leaks, or ruptured components will pierce skin. This may look like just a cut, but it is a serious injury that can result in amputation. Get immediate surgical treatment.</p> <ul style="list-style-type: none"> • Do not point gun at anyone or at any part of the body. • Do not put your hand over the spray tip. • Do not stop or deflect leaks with your hand, body, glove, or rag. • Do not spray without tip guard and trigger guard installed. • Engage trigger lock when not spraying. • Follow Pressure Relief Procedure in this manual, when you stop spraying and before cleaning, checking, or servicing equipment.

 WARNING	
	<p>FIRE AND EXPLOSION HAZARD</p> <p>Flammable fumes, such as solvent and paint fumes, in work area can ignite or explode. To help prevent fire and explosion:</p> <ul style="list-style-type: none"> • Use equipment only in well ventilated area. • Eliminate all ignition sources; such as pilot lights, cigarettes, portable electric lamps, and plastic drop cloths (potential static arc). • Keep work area free of debris, including solvent, rags and gasoline. • Do not plug or unplug power cords, or turn power or light switches on or off when flammable fumes are present. • Ground all equipment in the work area. See Grounding instructions. • Use only grounded hoses. • Hold gun firmly to side of grounded pail when triggering into pail. • If there is static sparking or you feel a shock, stop operation immediately. Do not use equipment until you identify and correct the problem. • Keep a working fire extinguisher in the work area.
	<p>PRESSURIZED ALUMINUM PARTS HAZARD</p> <p>Do not use 1,1,1-trichloroethane, methylene chloride, other halogenated hydrocarbon solvents or fluids containing such solvents in pressurized aluminum equipment. Such use can cause serious chemical reaction and equipment rupture, and result in death, serious injury, and property damage.</p>
	<p>EQUIPMENT MISUSE HAZARD</p> <p>Misuse can cause death or serious injury.</p> <ul style="list-style-type: none"> • Do not operate the unit when fatigued or under the influence of drugs or alcohol. • Do not exceed the maximum working pressure or temperature rating of the lowest rated system component. See Technical Data in all equipment manuals. • Use fluids and solvents that are compatible with equipment wetted parts. See Technical Data in all equipment manuals. Read fluid and solvent manufacturer's warnings. For complete information about your material, request MSDS forms from distributor or retailer. • Check equipment daily. Repair or replace worn or damaged parts immediately with genuine Graco replacement parts only. • Do not alter or modify equipment. • Use equipment only for its intended purpose. Call your Graco distributor for information. • Route hoses and cables away from traffic areas, sharp edges, moving parts, and hot surfaces. • Do not kink or over bend hoses or use hoses to pull equipment. • Keep children and animals away from work area. • Comply with all applicable safety regulations.
	<p>MOVING PARTS HAZARD</p> <p>Moving parts can pinch or amputate fingers and other body parts.</p> <ul style="list-style-type: none"> • Keep clear of moving parts. • Do not operate equipment with protective guards or covers removed. • Pressurized equipment can start without warning. Before checking, moving, or servicing equipment, follow the Pressure Relief Procedure in this manual. Disconnect power or air supply.
	<p>BURN HAZARD</p> <p>Equipment surfaces and fluid that's heated can become very hot during operation. To avoid severe burns, do not touch hot fluid or equipment. Wait until equipment/fluid has cooled completely.</p>

Temperature Control Diagnostic Codes

Temperature control diagnostic codes E01 through E05 appear on temperature display.

These alarms turn off heat. Turn main power OFF



Code No.	Code Name	Alarm Zone	Corrective Action page
01	High fluid temperature	Individual	7

02	High hose current	Hose only	8
03	No hose current with hose heater on	Hose only	8
04	FTS not connected	Individual	9
05	Board overtemperature	All	9
30	Momentary loss of communication	A	13
99	Loss of communication	A	13



For hose zone only, if FTS is disconnected at startup, display will show hose current 0A.

E01: High fluid temperature

Causes of E01 Errors

- Thermocouple A or B (210) senses a fluid temperature of 229°F (109°C).
- Fluid temperature sensor (FTS) senses a fluid temperature of 229°F (109°C).
- Overtemperature switch A or B (208) senses a fluid temperature of 230°F (110°C) and opens. At 190°F (87°C) the switch closes again.
- Thermocouple A or B (210) fails, is damaged, or is not touching the heater element (207).
- Overtemperature switch A or B (208) fails in the open position.
- The temperature control board fails to turn off any heat zone.
- A and B heaters power or thermocouple wiring is not connected properly.

Checks



Troubleshooting this equipment requires access to parts which may cause electric shock or other serious injury if work is not performed properly. Have a qualified electrician perform all electrical troubleshooting. Be sure to shut off all power to the equipment before repairing.

Check which zone is displaying the E01 error. Verify fluid temperature, using an external temperature sensing device.

- **If temperature *is not* too high (sensor reading is 190°F [87°C] or below):**

1. Check that connector J1 is firmly plugged into temperature control board (see FIG. 8, page 34).
2. Check connections between the temperature control board and overtemperature switches A and B (208), and between temperature control board and thermocouples A and B (210) or FTS (11) [depending on which zone is displaying E01]. See TABLE 7, page 32. Ensure that all wires are securely connected to connector J1.
3. Remove connector J1 from temperature control board, and check continuity of overtemperature switches A and B, thermocouples A and B, or FTS

by measuring resistance across the pins on the plug end; see TABLE 1.



Table 1: Connector J1 Continuity Checks

Pins	Description	Reading
1 & 2	OT switch A	nearly 0 ohms
3 & 4	OT switch B	nearly 0 ohms
7 & 8	Thermocouple A	4-6 ohms
10 & 11	Thermocouple B	4-6 ohms
12 & 13	FTS	approximately 35 ohms per 50 ft (15.2 m) of hose, plus approximately 10 ohms for FTS
12 & 14	FTS	infinity

- If temperature *is* too high (sensor reading is 229°F [109°C] or above):

 Before doing the following checks, note which zone (A, B, FTS, or all) has high fluid temperature. Cool the equipment, using the feed pumps to move cool material into the Reactor.

1. Check connections between the temperature control board and thermocouples A and B (210) and/or FTS (11). See TABLE 7, page 32. Ensure that all wires are securely connected to connector J1.
2. Remove connector J1 from temperature control board, and check continuity of thermocouples A and B and/or FTS by measuring resistance across pins; see TABLE 1.
3. Check if thermocouples A and B are damaged, or not contacting the heater element, page 37.
4. To test that temperature control board turns off when equipment reaches temperature setpoint:

- Turn main power OFF .
- Measure the voltage across the red and black leadwires to the heater elements.
- Turn main power ON .

- Set the A and B temperature setpoints below ambient temperature. Turn the heat zones on. The red light above each zone on the control panel should be blinking, and the voltmeter should read little or no voltage.
- If the voltmeter reads line voltage while the red light is blinking:
For zones A and B, replace the temperature control board; see page 32.
For hose zone, perform step 2 under **Test SCR Circuit**, page 33.

E02: High hose current

1. Check tap connection at transformer, see operation manual.
2. Check hose connections for electrical short, page 39.
3. Move to lower hose length on transformer.
4. Replace temperature control board, page 32.

E03: No hose current

 Do steps in order. Do not skip any step.

1. Test hose continuity, page 41. Check hose connectors for broken electrical connection, page 39. Flex hose, especially the whip hose, to pinpoint intermittent connections.
2. Check 50A (806) and 20A (817A) circuit breakers, page 27.
3. Test transformer wire harness continuity, page 41.
4. Test current sensor continuity, page 41.
5. If using a 380V model, perform **Test In-Rush Current Limiter** procedure, page 41.
6. Do **Transformer Primary Check**, page 43.
7. Do **Transformer Secondary Check**, page 43.
8. Test temperature control board SCR circuit, page 32.

E04: Fluid Temperature Sensor (FTS) or thermocouple A or B not connected

Causes of E04 Errors

- E04 on the A display: With power on, thermocouple A lost communication with the temperature control board.
- E04 on the B display: With power on, thermocouple B lost communication with the temperature control board.
- E04 on the hose heat display: With power on, the FTS lost communication with the temperature control board.

Check Thermocouples A and B

1. Remove connector J1 from temperature control board. Ensure that wires are securely connected to pins 7-11. See TABLE 7, page 32.
2. Using an ohmmeter, check resistance of thermocouple A:
 - a. With connector J1 disconnected, measure resistance across pins 7 and 8. Resistance should be 4-6 ohms; if not, replace thermocouple A, see page 37.
 - b. Measure resistance between pin 7 and the thermocouple housing; resistance should be infinity. Then measure resistance between pin 8 and the thermocouple housing; resistance should be infinity. If not, replace thermocouple A, page 37.
3. Using an ohmmeter, check resistance of thermocouple B:
 - a. With connector J1 disconnected, measure resistance across pins 10 and 11. Resistance should be 4-6 ohms; if not, replace thermocouple B, see page 37.

- b. Measure resistance between pin 10 and the thermocouple housing; resistance should be infinity. Then measure resistance between pin 11 and the thermocouple housing; resistance should be infinity. If not, replace thermocouple B, page 37.

Check FTS

1. Check cable connections between all hose lengths.
2. Ensure that FTS wires are securely connected to pins 12-14 at connector J1 on temperature control board. See TABLE 7, page 32.
3. Check FTS by connecting directly to Reactor:
 - a. Unplug the hose cable from the cable connector (F) at the Reactor.

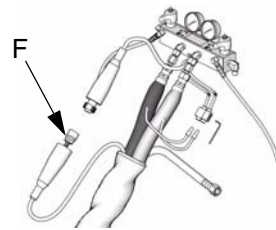

ti9878

- b. Bring the FTS close to the Reactor and plug its cable directly into the cable connector (F) at the Reactor.

4. Check FTS with ohmmeter, page 39.

E05: Board overtemperature

 The temperature control board has its own sensor which will shut down if the board exceeds 176°F (80°C).

1. Check fan operation.
2. Check that electrical cabinet door is properly installed.
3. Check for obstructions blocking cooling holes in bottom of Reactor.
4. Ambient temperature too high. Move Reactor to a cooler location.

Motor Control Diagnostic Codes

Motor control diagnostic codes E21 through E27 appear on pressure display.

There are two types of motor control codes: alarms and warnings. Alarms take priority over warnings.

Alarms

Alarms turn off Reactor. Turn main power OFF

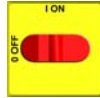

then ON





to clear.

Alarms can also be cleared, except for code 23, by pressing .

Warnings

Reactor will continue to run. Press  to clear. A warning will not recur for a predetermined amount of time (varies for different warnings), or until main power

is turned OFF  then ON .

Code No.	Code Name	Alarm (A) or Warning (W)	Corrective Action page
21	No transducer (component A)	A	11
22	No transducer (component B)	A	11
23	High fluid pressure	A	11
24	Pressure imbalance	A/W (to select, see page 29)	11
27	High motor temperature	A	13
30	Momentary loss of communication	A	13
31	Pumpline reversing switch failure/high cycle rate	A	13
99	Loss of communication	A	13

E21: No component A transducer

1. Check transducer A connection at J3 on motor control board, page 30.
2. Reverse A and B transducer connections. If error moves to transducer B (E22), replace transducer A, page 31. If error does not move, replace motor control board, page 29.

E22: No component B transducer

1. Check transducer B connection at J8 on motor control board, page 30.
2. Reverse A and B transducer connections. If error moves to transducer A (E21), replace transducer B, page 31. If error does not move, replace motor control board, page 29.

E23: High fluid pressure

1. Relieve pressure. Verify low pressure with analog

gauges. Turn main power OFF  then ON



. If error persists, do checks below.

2. If pressure imbalance is set to Warning instead of Alarm (see page 29), an E23 will occur. See **E24: Pressure imbalance**, below, for causes and checks.

E24: Pressure imbalance



If the pressure difference between components A and B exceeds 500 psi (3.5 MPa, 35 bar), an E24 will occur. This default value is adjustable; see the operation manual.



E24 can be an alarm or a warning, as desired. Set DIP switch on motor control board ON for alarm, OFF for warning. See page 29.

Fast E24 Errors

Fast E24 errors occur:

- within 10 sec of turning the pumps on, or
- as soon as you trigger the gun.

Causes of Fast E24 Errors

- one side of the gun is plugged.
- a pressure transducer has failed.
- damaged pump seals or check valve.
- no feed pressure or empty material drum
- plugged heater.
- plugged hose.
- plugged manifold.
- one PRESSURE RELIEF/SPRAY valve is leaking or is set to PRESSURE RELIEF.

Checks for Fast E24 Errors



If a fast E24 error occurs, first check the readings of the analog gauges.

- **If the gauge readings are very close:**

1. Clear the error (page 10) and try running the unit again.
2. If E24 recurs and the gauge readings are still very close, a pressure transducer has failed.

The digital display always shows the higher of the two pressures. As soon as the higher analog pressure drops below the lower analog pressure, the display changes to the new higher reading. Knowing this, the following checks will show which transducer has failed, or if the motor control board has failed.

- a. For testing purposes only, set DIP switch 2 on the motor control board to OFF. See page 29. This will allow the Reactor to continue to run with a pressure imbalance.
- b. Run the unit until pressure is 1000-1500 psi (7-10.5 MPa, 70-105 bar). Shut down the unit, clear the alarm, and power back up, but do not depressurize the unit.
- c. Check the analog gauges to see which pressure is higher, and check if the display matches.

If the higher gauge and display match, that transducer is communicating with the motor control board. Continue with step d.

If the higher gauge and display do not match, that transducer is not communicating with the motor control board. Check wire connections and replace transducer, page 31.

- d. Turn pumps off. Reduce pressure of higher component by **slightly** turning PRESSURE RELIEF/SPRAY valve for that component toward PRESSURE RELIEF, while watching the display and the analog gauges. As soon as the higher analog pressure drops below the lower analog pressure, the display should change to the new higher reading. Continue reducing the original higher pressure an additional 200 psi (1.4 MPa, 14 bar); digital display should stop dropping.
- e. Repeat for the other side, to check the other transducer.

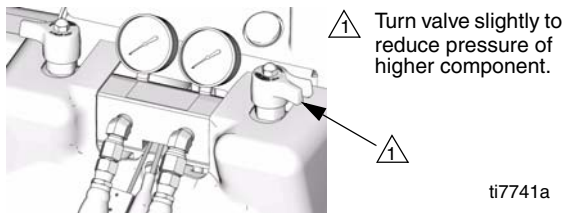



3. To test if the failure is with the transducer or the socket on the motor control board:
 - a. Reverse connections at J3 and J8 on the motor control board.
 - b. Run the unit until pressure is 1000-1500 psi (7-10.5 MPa, 70-105 bar).

- c. If the problem stays on the same side as before, replace the transducer. If the problem appears to move to the other side, replace the motor control board.

• **If the gauge readings are not very close:**

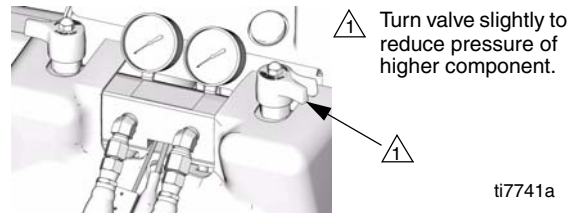
1. Secure bleed lines in grounded waste containers, or route back to respective component A or B supply drum. Reduce pressure of higher component by **slightly** turning PRESSURE RELIEF/SPRAY valve for that component toward PRESSURE RELIEF, until gauges show balanced pressures.



 Turn PRESSURE RELIEF/SPRAY valve only enough to balance pressure. If you turn it completely, all pressure will bleed off.

2. If you cannot get the pressures to balance:
 - a. Check for damaged pump seals or check valves.
 - b. Check if you've run out of material.
 - c. Check for a plugged fluid path by using the feed pump to push fluid through the gun manifold.
3. If you are able to balance pressures, try running the unit.
4. If a fast E24 error occurs again, and the gauges readings are not very close:
 - a. Check and clean the gun inlet screens.
 - b. Check and clean the gun mix chamber impingement ports and center port. See gun manual.

 Some mix chambers have counter bored impingement ports, requiring two drill sizes to clean completely.

Slow E24 Errors

Slow E24 errors occur gradually. The pressures are balanced when you begin spraying, but slowly become imbalanced until an E24 occurs.

Causes of Slow E24 Errors

- one side of the gun is partially plugged.
- the A or B proportioner pump has failed.
- the A or B feed pump has failed.
- the A or B feed pump pressure is set too high.
- the A or B proportioner pump inlet screen is plugged.
- the hose is not heating properly.
- kinked supply hose.
- bottom of drum is damaged, causing blockage of feed pump inlet.
- drum is not vented.

E27: High motor temperature

Causes of E27 Errors

- Motor temperature is too high. Reduce pressure, gun tip size, or move Reactor to a cooler location. Allow 1 hour for cooling.
- Make sure there is no obstruction to fan airflow. Ensure that the motor/fan shroud is installed.
- Check that the motor overtemperature wire assembly is plugged into J9 on the motor control board, page 30.
- If the preceding checks do not correct the problem, perform the following tests:



1. Turn main power OFF.
2. Allow motor to cool completely. Check continuity between pins 1 and 2 on connector J9 on the motor control board, page 29. If the resistance is infinity, the motor thermal switch or the wire harness is bad. Check wiring, measure thermal switch continuity at motor, and replace failed part.
3. Unplug motor from J9 on motor control board. Install jumper across pins 1 and 2 on board. If error still occurs, replace motor control board.
4. If the E27 error is still occurring, the problem is with the motor control board.

E30: Momentary loss of communication

If communication is lost between the display and either of the boards, the display will normally show E99. The corresponding control board will register E30 (the red LED will blink 30 times). When communications are reconnected, the display may show E30 briefly (no more than 2 sec). If the display shows E30 continuously, there is a loose connection causing the display and board to repeatedly lose and regain communication.

E31: Pumpline reversing switch failure/high cycle rate

Failure of a pumpline switch or switch mechanism may result in a high cycle rate, causing an E31 to occur. Replace the switch or switch mechanism, page 23.

E31 may also occur if the system is modified to produce a higher flow rate.



E99: Loss of communication

If communication is lost between the motor control display and the motor control board, or the temperature control display and the temperature control board, the affected display will show E99.

1. Check all wiring between the display and the boards. Pay close attention to the wire crimping at J13 on the motor control board (page 30) and J5 on the temperature control board (page 34).
2. Incoming voltage to both boards should be 230 Vac. Check the temperature control board voltage at terminal block (809) on the circuit breaker module (see pages 69-70). Check the motor control board voltage at motor/pumps circuit breaker (817B), see page 27.

Troubleshooting

Reactor Electronics

PROBLEM	CAUSE	SOLUTION
Reactor does not operate.	No power.	Plug in power cord.
		Turn main power ON  .
		Turn circuit breakers ON, page 27.
	Red stop button circuit open.	Check button connections. See page 45 and electrical diagrams.
	Line voltage not within specified range.	See Technical Data , page 72.
No display.	Main power OFF.	Turn main power ON  .
	Loose display cable.	Check cable connections, page 45.
	Both display boards failed.	Check boards, replace; page 45.
No temperature display.	Loose display cable.	Check cable connections, page 45.
	Defective display cable.	Disconnect temperature and pressure display cables from display boards and reverse cables. If fault moves to pressure display, replace cable, page 45.
	Failed temperature control board.	Open cabinet. Check if board LED is blinking. If not, check power wiring connections to ensure board has power. If board has power and LED is not blinking, replace board, page 32.
	Inadequate power to temperature board.	Check that power supply meets requirements.
	Loose power cable (internal to display).	Check cable connections, page 45.
	Defective display board.	Replace, page 45.

PROBLEM	CAUSE	SOLUTION
No pressure display.	Loose display cable.	Check cable connections, page 45.
	Defective display cable.	Disconnect temperature and pressure display cables from display boards and reverse cables. If fault moves to temperature display, replace cable, page 45.
	Failed motor control board.	Open cabinet. Check if board LED is lighted. If not, replace board, page 29.
	Inadequate power to motor control board.	Check that power supply meets requirements.
	Loose power cable.	Check cable connections, page 45.
	Defective display board.	Replace, page 45.
	Circuit breaker tripped.	Reset breaker.
Hose display reads 0A on startup.	FTS not installed and  zone off.	Install FTS (see operation manual), or adjust current to desired setting.
Erratic display; display turns on and off	Cable not grounded.	Ground cable, page 45.
	Extension cable too long.	Must not exceed 300 ft (91.5 m).
Display buttons do not work properly; cannot get out of an operation.	Broken membrane switch.	Replace, page 45.
	Ribbon cable disconnected or broken.	Connect cable, or replace.
Red stop button does not work.	Broken button (fused contact).	Replace, page 45.
	Loose wire.	Check connections, page 45.
Fan not working.	Blown fuse.	Replace, page 31.
	Loose wire.	Check.
	Defective fan.	Replace, page 31.

Primary Heaters (A and B)



Before performing any troubleshooting procedures:

1. Relieve pressure, page 24.

2. Turn main power OFF



3. Allow equipment to cool.

Try the recommended solutions in the order given for each problem, to avoid unnecessary repairs. Also, determine that all circuit breakers, switches, and controls are properly set and wiring is correct before assuming there is a problem.

PROBLEM	CAUSE	SOLUTION
Primary heater circuit breaker(s) trips (E01 error).	Surface temperature of the heater exceeds 230°F (110°C).	See Overtemperature Switch , page 38.
Primary heater(s) does not heat; red LED on the temperature control board is on.	Circuit breaker(s) tripped.	Reset circuit breaker 804A or 804B. See Circuit Breaker Module , page 27.
	Heat turned off.	Press A or B zone I keys.
	Temperature control alarm.	Check temperature displays for diagnostic code, page 7.
	Faulty temperature control board.	Open cabinet. Check if board LED is blinking. If not, check power wiring connections to ensure board has power. If board has power and LED is not blinking, replace board, page 32.
	Loose connectors or wire nuts.	Check connections.
	Faulty heater element(s).	See Primary Heaters , page 35.
	Signal failure from thermocouple.	See Check Thermocouples A and B , page 9.
Primary heater(s) heats but red LED on the temperature control board is on continuously.	Faulty temperature control board.	Open cabinet. Check if board LED is blinking. If not, check power wiring connections to ensure board has power. If board has power and LED is not blinking, replace board, page 32.
	Faulty heater element(s).	See Primary Heaters , page 35.

PROBLEM	CAUSE	SOLUTION
<p>Low heat in A or B zones; primary heater(s) partially heats but red LED on the temperature control board is on almost continuously.</p>	Faulty heater element(s).	See Primary Heaters , page 35.
	Low line voltage.	Check that voltage is adequate. See Technical Data , page 72.
	Ambient conditions.	<p>Move unit to warmer area.</p> <p>Reduce fluid flow.</p> <p>Use auxiliary hose heater.</p>
	A and B temperature setpoints too low.	Check setpoint. Increase if necessary.
	Flow too high.	Use smaller mix chamber. Decrease pressure.
	Defective thermocouples.	See Check Thermocouples A and B , page 9.
	Faulty heater element(s).	See Primary Heaters , page 35.
	Loose connectors or wire nuts.	Check connections.
	Overheated temperature control board.	Check fan operation.
		Check if door is open; close.
Check that cooling holes are not clogged or obstructed.		
<p>When flow starts, the red LED on the temperature control board turns on and stays on almost continuously for 30 sec or more.</p>	Faulty heater element(s).	See Primary Heaters , page 35.

Hose Heat System



Before performing any troubleshooting procedures:

1. Relieve pressure, page 24.

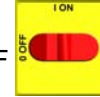

2. Turn main power OFF



3. Allow equipment to cool.

Problems

Try the recommended solutions in the order given for each problem, to avoid unnecessary repairs. Also, determine that all circuit breakers, switches, and controls are properly set and wiring is correct before assuming there is a problem.

PROBLEM	CAUSE	SOLUTION
Hose heats but does not reach temperature or takes too long to reach temperature.	Hose is too long.	The hose heat system will maintain the temperature developed by the primary heaters with up to 210 ft (64 m) of hose. Longer hoses require an auxiliary hose heat system.
	Ambient temperature is too cold.	Use auxiliary hose heat system.
Hose does not heat.	Hose heat primary circuit breaker (817A) tripped.	Reset circuit breaker. See Circuit Breaker Module , page 27.
	Hose heat secondary circuit breaker (806) tripped.	Reset circuit breaker. See Circuit Breaker Module , page 27.
	Hose zone not turned on.	Press  zone  key.
	A and B temperature setpoints too low.	Increase A and B setpoints. Hose designed to maintain temperature, not increase temperature.
	Loose hose electrical connections.	Check connections. Repair as necessary.
	Faulty temperature control board.	Open cabinet. Check if board LED is blinking. If not, check power wiring connections to ensure board has power. If board has power and LED is not blinking, replace board, page 32.
	Loss of signal from the FTS.	See Check FTS , page 9.
	Hose heating element.	See E03: No hose current , page 8.
<i>380V only:</i> In-rush current limiter does not close when hose heat is turned on.	Test In-Rush Current Limiter , page 41.	

PROBLEM	CAUSE	SOLUTION
Hose temperature not maintained during flow.	A and B temperature setpoints too low.	Increase A and B setpoints. Hose designed to maintain temperature, not increase temperature.
	Hose temperature setpoint too low.	Check. Increase if necessary to maintain heat.
	Flow too high.	Use smaller mix chamber. Decrease pressure.
	Low current; FTS not installed.	Install FTS, see operation manual.
	Hose heat zone not turned on long enough.	Allow hose to heat up, or preheat fluid.
	Loose hose electrical connections.	Check connections. Repair as necessary.
	Loss of signal from the FTS.	See Check FTS , page 9.
	Low line voltage.	The hose heat system operates from 230 Vac. Low line voltage will significantly reduce power available and the heater will not perform to its full capability at maximum hose length.
Hose or hoses near unit are warm, hoses downstream are cold.	Hose heating element.	See E03: No hose current , page 8.
	Circuit breakers tripped.	Reset breakers (806 or 817A), page 27.
	Failed temperature control board.	Open cabinet. Check if board LED is blinking. If not, check power wiring connections to ensure board has power. If board has power and LED is not blinking, replace board, page 32.
	Loss of signal from the FTS.	See Check FTS , page 9.

Hydraulic Drive System



Before performing any troubleshooting procedures:

1. Relieve pressure, page 24.

2. Turn main power OFF

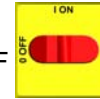

3. Allow equipment to cool.

Problems

Try the recommended solutions in the order given for each problem, to avoid unnecessary repairs. Also, determine that all circuit breakers, switches, and controls are properly set and wiring is correct before assuming there is a problem.

PROBLEM	CAUSE	SOLUTION
Electric motor will not start or stops during operation.	Loose connections.	Check connections at motor control board.
	Circuit breaker tripped.	Reset breaker (817B), page 27. Check 230Vac at output of breaker.
	Damaged motor control board.	Replace board. See page 29.
Hydraulic pump does not develop pressure. Low or zero pressure with screeching noise.	Pump is not primed or lost its prime	Check electric motor rotation. See Main Power Installation in the Operation manual.
		Check dipstick to ensure that hydraulic reservoir is properly filled (see Operation manual).
		Check that inlet fitting is fully tight, to ensure no air is leaking into the pump inlet.
	To prime pump, remove case drain fitting (12j, page 56) from top of pump housing and slowly fill pump with hydraulic oil.	
Screeching noise is characteristic of cavitation and is normal at initial startup for a maximum of 30 seconds.	If noise continues longer than 30 seconds, press motor  key to shut off the motor. Check that the inlet fittings are tight and that the pump has not lost its prime.	
Hydraulic fluid is too hot.	Ensure that the reservoir is properly serviced. Improve ventilation to allow more efficient heat dissipation.	

Proportioning System



Before performing any troubleshooting procedures:

1. Relieve pressure, page 24.

2. Turn main power OFF

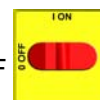

3. Allow equipment to cool.

Problems

Try the recommended solutions in the order given for each problem, to avoid unnecessary repairs. Also, determine that all circuit breakers, switches, and controls are properly set and wiring is correct before assuming there is a problem.

PROBLEM	CAUSE	SOLUTION
Proportioning pump does not hold pressure when stalled.	Pump piston or intake valve leaking.	<ol style="list-style-type: none"> 1. Observe gauges to determine which pump is losing pressure. 2. Determine in which direction the pump has stalled by observing which directional valve indicator light is on. See Table 2, page 23 to isolate the problem. 3. Repair the valve; see pump manual 311391.
Material imbalance. See Pressure/Material Imbalance , page 23.	Restriction at the gun.	Clean the gun; see your separate gun manual.
	Inadequate flow from pump; cavitation.	Increase fluid supply to proportioning pump: <ul style="list-style-type: none"> • Use 2:1 supply pump • Use minimum 3/4 in. (19 mm) ID supply hose, as short as practical
		Fluid is too thick. Consult your material supplier for the recommended fluid temperature to maintain a viscosity of 250 to 1500 centipoise.
		Clean inlet strainer screen, page 47.
Pumps do not reverse direction.	Bent or loose activator plate, rocker arm, or reversing switch.	See Pumps Do Not Reverse Direction , page 23.
	Loose piston packing bolt.	See Pumps Do Not Reverse Direction , page 23.
Pumps do not move, and both directional lights are out.		See Pumps Do Not Reverse Direction , page 23.

PROBLEM	CAUSE	SOLUTION
Erratic pump movement.		See Pumps Do Not Reverse Direction , page 23.
Pump output low.	Obstructed fluid hose or gun; fluid hose ID too small.	Open, clear; use hose with larger ID.
	Worn piston valve or intake valve in displacement pump.	See pump manual 311391.
	Inadequate feed pump pressure.	Check feed pump pressure and adjust to 100 psi (0.7 MPa, 7 bar) minimum.
Fluid leak at pump rod seal.	Worn throat seals.	Replace. See pump manual 311391.
No pressure on one side.	Fluid leaking from pump outlet rupture disk (47).	Check if heater (2) and PRESSURE RELIEF/SPRAY valve (SA or SB) are plugged. Clear. Replace rupture disk (47) with a new one; do not replace with a pipe plug.
	Inadequate feed pump pressure.	Check feed pump pressure and adjust to 100 psi (0.7 MPa, 7 bar) minimum.

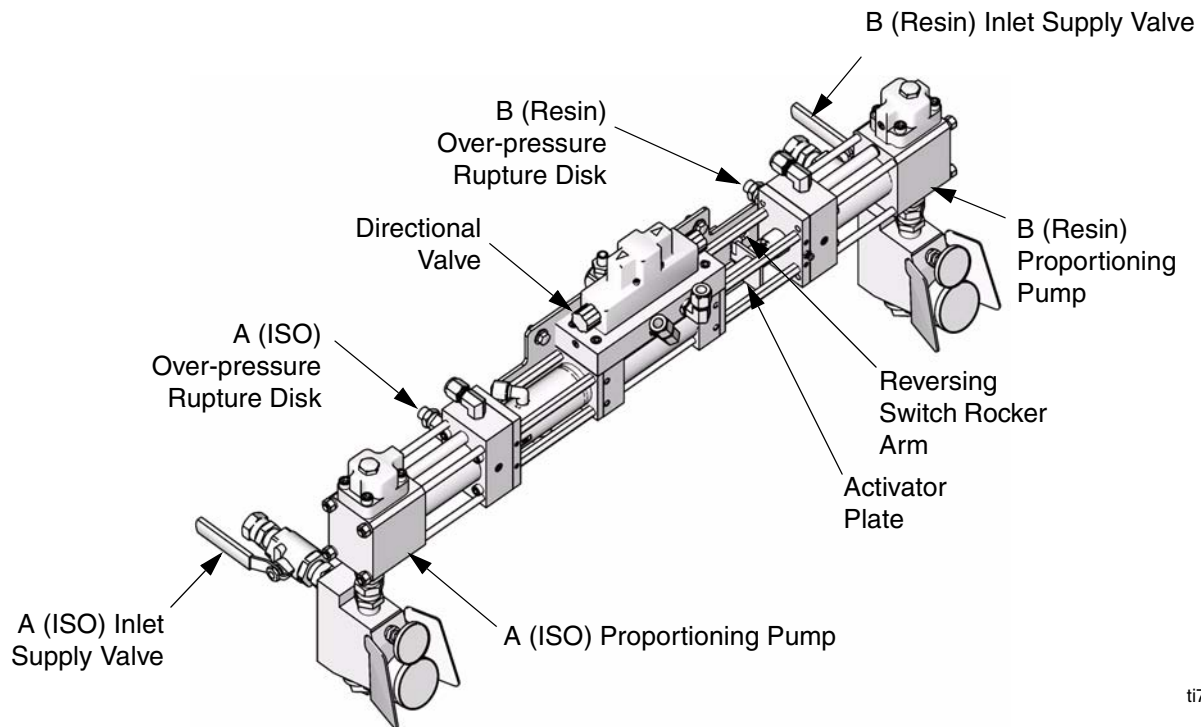

ti7735a

FIG. 1. Proportioning System

Table 2. Directional Valve Indicator Status

Left Pump Directional Indicator Lighted	Right Pump Directional Indicator Lighted
B-side pump piston valve dirty or damaged	B-side pump inlet valve dirty or damaged
A-side pump inlet valve dirty or damaged	A-side pump piston valve dirty or damaged

Pressure/Material Imbalance

To determine which component is out of balance, check the color of some sprayed material. Two-component materials are usually a mix of light and dark fluids, so the under-proportioned component can often be readily determined.



When you have determined which component is under-proportioned, spray off-target, focusing on the pressure gauge for that component.

For example: if component B is under-proportioned, focus on the B-side pressure gauge. If the B gauge reads considerably higher than the A gauge, the problem is at the gun. If the B gauge reads considerably lower than the A gauge, the problem is at the pump.



Pumps Do Not Reverse Direction

1. For the proportioning pumps to reverse direction, the activator plate (122) must contact the rocker arm to activate the reversing switch (137). Check for a bent or loose activator plate, rocker arm, or reversing switch. See FIG. 1 on page 22, and the parts drawing on page 54.
2. If a bent or loose activator plate, rocker arm, or reversing switch is not the cause, check for a loose piston packing retaining bolt. This causes the piston to contact the inner face of the pump inlet flange before the activator plate contacts the rocker arm. Shut down the unit and disassemble the appropriate pump for repair.

Repair

							
<p>Repairing this equipment requires access to parts which may cause electric shock or other serious injury if work is not performed properly. Have a qualified electrician connect power and ground to main power switch terminals, see operation manual. Be sure to shut off all power to the equipment before repairing.</p>							

Pressure Relief Procedure

							
---	---	--	--	--	--	--	--

1. Relieve pressure in gun and perform gun shut-down procedure. See gun manual.
2. Close gun fluid manifold valves A and B.

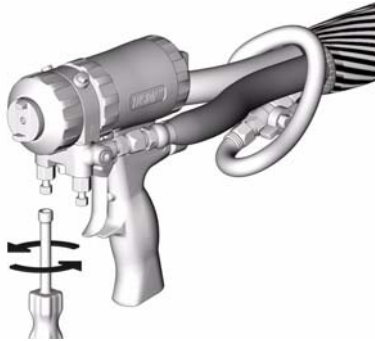

ti2421a

3. Shut off feed pumps and agitator, if used.

4. Turn PRESSURE RELIEF/SPRAY valves (SA, SB) to PRESSURE RELIEF. Route fluid to waste containers or supply tanks. Ensure gauges drop to 0.

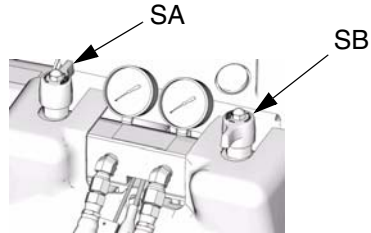

ti7740a

5. Engage gun piston safety lock.



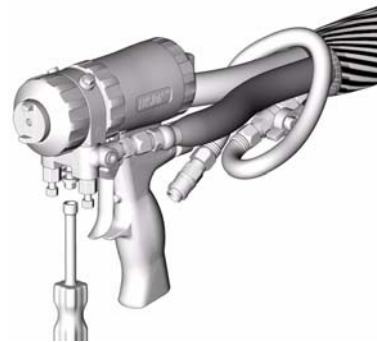

ti2409a

6. Disconnect gun air line and remove gun fluid manifold.



ti2554a

Flushing

						
<p>Flush equipment only in a well-ventilated area. Do not spray flammable fluids. Do not turn on heaters while flushing with flammable solvents.</p>						

- Flush out old fluid with new fluid, or flush out old fluid with a compatible solvent before introducing new fluid.
- Use the lowest possible pressure when flushing.
- All fluid components are compatible with common solvents. Use only moisture-free solvents.

- To flush feed hoses, pumps, and heaters separately from heated hoses, set PRESSURE RELIEF/SPRAY valves (SA, SB) to PRESSURE RELIEF. Flush through bleed lines (N).

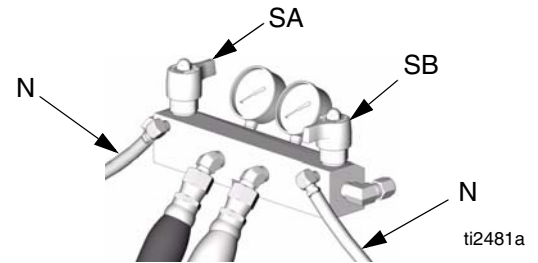

- To flush entire system, circulate through gun fluid manifold (with manifold removed from gun).
- To prevent moisture from reacting with isocyanate, always leave the system dry or filled with a moisture-free plasticizer or oil. Do not use water.

Proportioning Pumps

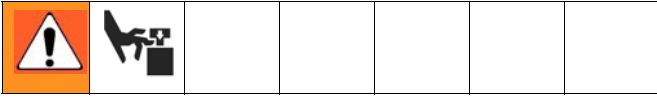

See manual 311391 for pump repair instructions.

1. Shut off **A** , **B** , and **Q** heat zones.
2. Flush, page 25.
3. If pumps are not parked, press Trigger gun until pumps stop.
4. Turn main power OFF . Disconnect power supply.
5. Shut off both feed pumps. Close both fluid inlet ball valves (B).

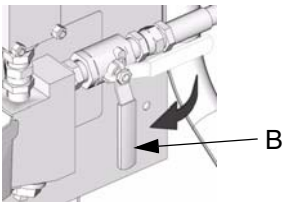

ti7737a

6. Turn both PRESSURE RELIEF/SPRAY valves (SA, SB) to PRESSURE RELIEF. Route fluid to waste containers or supply tanks. Ensure gauges drop to 0.

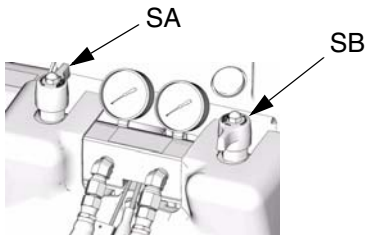

ti7740a

Use dropcloth or rags to protect Reactor and surrounding area from spills.

7. See FIG. 2. Disconnect the pump inlet and outlet lines. Remove the pin (149) from the clevis (140) to

disconnect the pump from the hydraulic cylinder. Remove the four screws (124) holding the pump to the spacers (313) of the hydraulic cylinder (134). Take the pump assembly to a workbench.

8. See manual 311391 for pump repair instructions.
9. Reconnect the pump in the reverse order. Torque the screws (124) to 200 in-lb (22.6 N•m).

Torque to 200 in-lb (22.6 N•m).

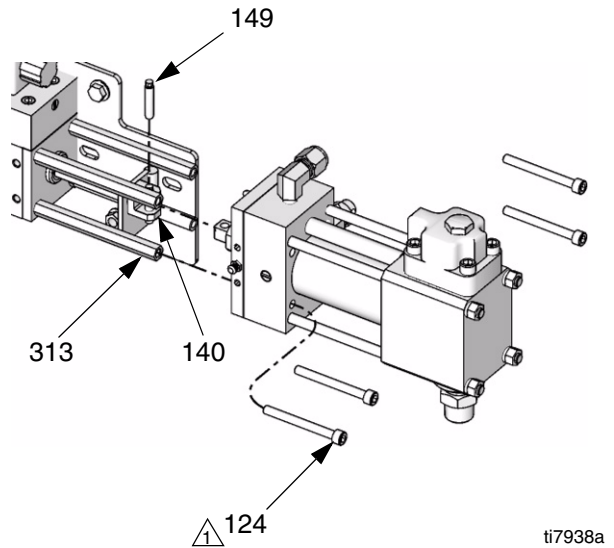

ti7938a

FIG. 2. Proportioning Pump

Circuit Breaker Module

1. Turn main power OFF . Disconnect power supply. Turn circuit breakers on to test.

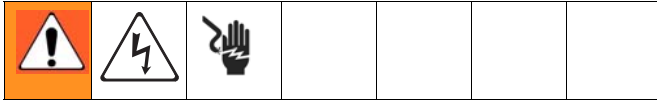

2. Relieve pressure, page 24.
3. Using an ohmmeter, check for continuity across circuit breaker (top to bottom). If no continuity, trip breaker, reset, and retest. If still no continuity, replace breaker as follows:
 - a. Refer to electrical diagrams and to TABLE 3. Disconnect wires and remove bad breaker.
 - b. Install new breaker and reconnect wires.

Table 3: Circuit Breakers, see FIG. 3

Ref. No.	Size	Component
806	50 A	Hose/Transformer Secondary Side
817A	20 A	Transformer Primary
804A	25 or 40 A*	Heater A
804B	25 or 40 A*	Heater B
817B	20 A	Motor/Pumps

* Depending on model.

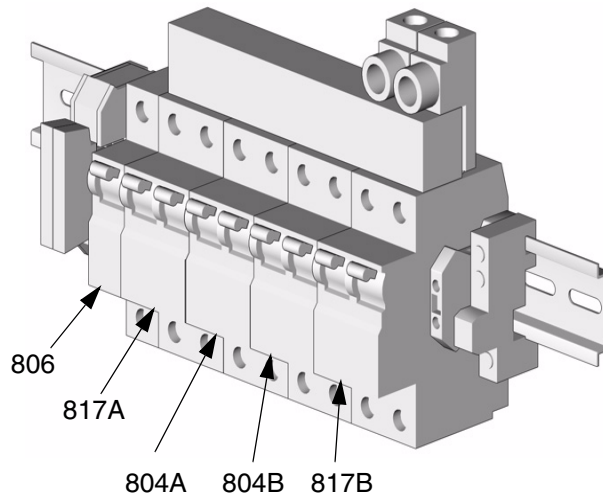

NOTE: To reference cables and connectors, see the electrical diagrams and the parts drawings on pages 69-70.

ti2514a

FIG. 3. Circuit Breaker Module

Electric Motor

Removal

1. Turn main power OFF . Disconnect power supply.

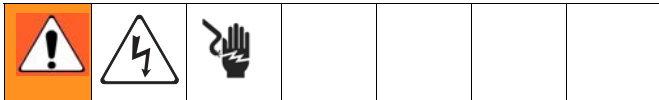

2. Relieve pressure, page 24.
3. Remove motor shroud.
4. Disconnect motor cables as follows:
 - a. Refer to electrical diagrams. Motor control board is on right side inside cabinet, see page 29.
 - b. Remove motor electric junction box cover.
 - c. Make a note of or label the wire connections. Refer to the electrical diagram manual 311508 and the diagram inside the motor junction box cover. The motor must operate counterclockwise when looking at the output shaft.

CAUTION

Motor is heavy. Two people may be required to lift.

5. Remove screws holding motor to bracket. Lift motor off unit.

Installation

1. Place motor on unit.
2. Fasten motor with screws.
3. Connect the wires, using wire nuts. Refer to the electrical diagram manual 311508 and the diagram inside the motor junction box cover. The motor must operate counterclockwise when looking at the output shaft.
4. Return to service.

Motor Control Board

 Motor control board has one red LED (D11). Power must be on to check. See FIG. 4 for location. Function is:

- Startup: 1 blink for 60 Hz, 2 blinks for 50 Hz.
- Motor running: LED on.
- Motor not running: LED off.
- Diagnostic code (motor not running): LED blinks diagnostic code, pauses, then repeats (for example, E21=21 blinks, pause, 21 blinks).

CAUTION
Before handling board, put on a static conductive wrist strap to protect against static discharge which can damage board. Follow instructions provided with wrist strap.

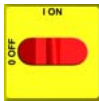
1. Turn main power OFF . Disconnect power supply.

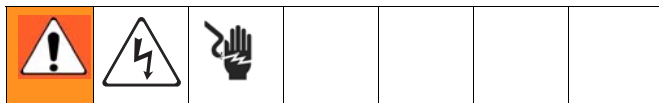

2. Relieve pressure, page 24.
3. Refer to electrical diagrams. Motor control board is on right side inside cabinet.
4. Put on static conductive wrist strap.
5. Disconnect all cables and connectors from board.
6. Remove nuts (42) and take entire motor control assembly to workbench.
7. Remove screws and take board off heatsink.
8. Set DIP switch (SW2) on new board. See TABLE 4 for factory settings. See FIG. 4 for location on board.



						
To prevent overpressurization, DIP switch 2 must be set to ON for Model H-25.						

Table 4: DIP Switch (SW2) Settings

DIP Switch	ON (up)	OFF (down)
Switch 1	Motor soft start ON (factory default)	Motor soft start OFF
Switch 2	ON for pressure imbalance alarm (factory default)	OFF for pressure imbalance warning
Switch 3	Standby ON	Standby OFF (factory default)
Switch 4	ON for Model H-25 (system dependent)	OFF for Model H-XP2 (system dependent)

9. Install new board in reverse order. Apply thermal heatsink compound to mating surfaces of board and heatsink.

 Order Part No. 110009 Thermal Compound.

Table 5: Motor Control Board Connectors

Connector	Pin	Description
J1	n/a	Main power
J3	n/a	Transducer A
J4	n/a	Not used
J7	n/a	Not used
J8	n/a	Transducer B
J9	n/a	Motor thermostat (NC)
J10	n/a	Not used
J12	n/a	Data reporting
J13	n/a	To display board
J14	n/a	Motor power
J18	1	Directional valve, A+
	2	Directional valve, A-
	3	Directional valve, B+
	4	Directional valve, B-
	5	GND
J5	1	Pumpline reversing switch (COM)
	2	Pumpline reversing switch (NC)
	3	Pumpline reversing switch (NO)

Motor Control for H-25 and H-XP2

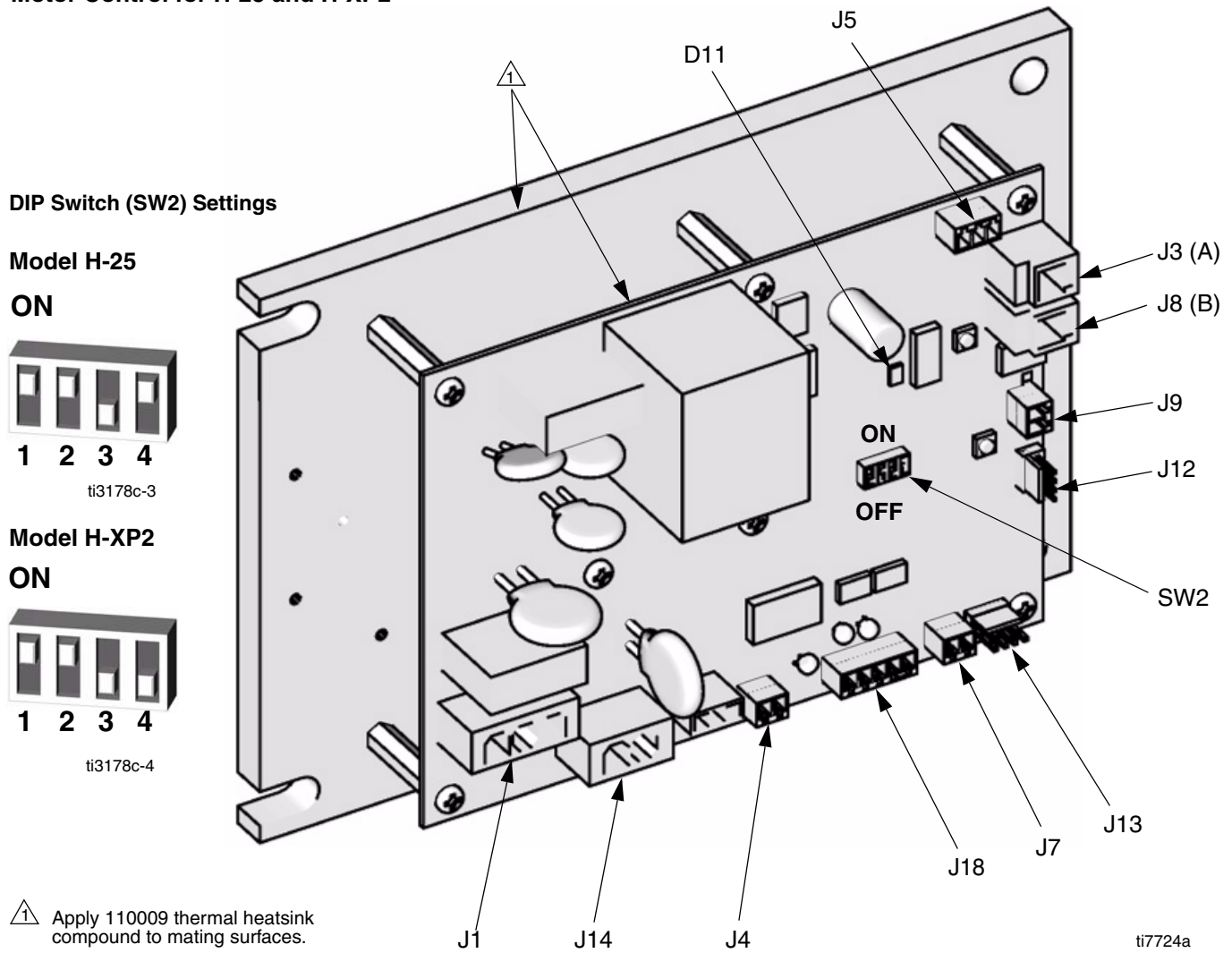
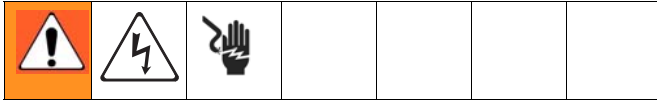

FIG. 4. Motor Control Board

Transducers

1. Turn main power OFF . Disconnect power supply.



2. Relieve pressure, page 24.
3. Refer to electrical diagrams. Motor control board is on right side inside cabinet.

4. Disconnect transducer cables at board; see FIG. 4, page 30. Reverse A and B connections and check if diagnostic code follows, page 11.
5. If transducer fails test, thread cable through top of cabinet. Note path as cable must be replaced in same way.
6. Install o-ring (720) on new transducer (706), FIG. 5.
7. Install transducer in manifold. Mark end of cable with tape (red=transducer A, blue=transducer B).
8. Route cable into cabinet and thread into bundle as before.
9. Connect transducer cable at board; see FIG. 4, page 30.

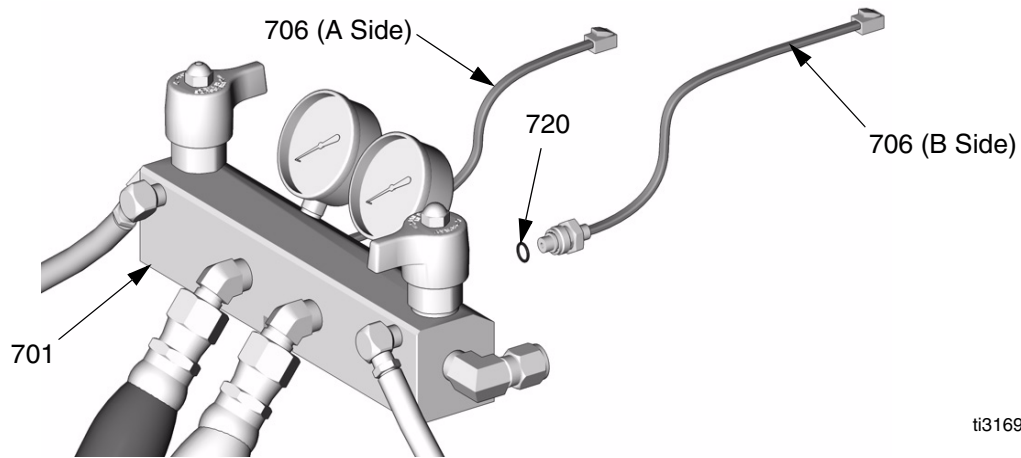

ti3169a

FIG. 5. Transducers

Electric Fan

1. Turn main power OFF . Disconnect power supply.

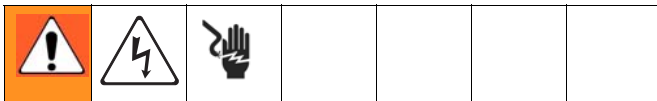

2. Relieve pressure, page 24.
3. Check fuses (F) at left of breaker module, FIG. 6. Replace if blown. If good, continue with step 4.
4. Refer to electrical diagrams. Disconnect fan wires from fuses (F). Thread wires through top of cabinet.

5. Remove fan.
6. Install fan in reverse order.

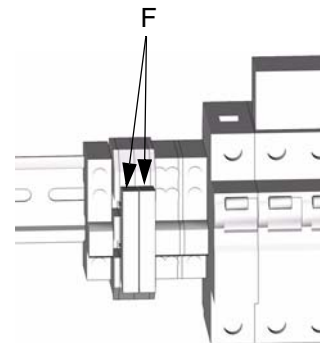

ti2514a-1

FIG. 6. Fan Fuses

Temperature Control Board

 Temperature control board has seven green LEDs. Power must be on to check. See FIG. 4 for location.

Table 6: Temperature Control Board LEDs

LED	Status	Function
D26	blinks	Board powered
D14	on	Zone A turned on
D13	cycles on and off	Zone A powered, LED cycles as temperature cycles
D18	on	Zone B turned on
D19	cycles on and off	Zone B powered, LED cycles as temperature cycles
D27	on	Hose zone turned on
D15	cycles on and off	Hose zone powered, LED cycles as temperature cycles

Table 7: Temperature Control Board Connectors

Connector	Pin	Description
J1	1, 2	Overtemperature switch A
	3, 4	Overtemperature switch B (on models with 15.3 kW heaters)
	5, 6	Current sensor
	7	Thermocouple A, red
	8	Thermocouple A, yellow
	9	Not used
	10	Thermocouple B, red
	11	Thermocouple B, yellow
	12	FTS, silver (unshielded bare wire)
	13	FTS, red
J2	n/a	To A heaters
J5	n/a	To display board
J8	n/a	Data reporting
J9	n/a	To B heaters
J13	n/a	To heated hose

Test SCR Circuit



1. Test the SCR circuit in the on position:

a. Make sure everything is connected, including the hose.

b. Turn main power ON



c. Adjust the hose heat setpoint **above** the ambient hose temperature.

d. Turn on  heat zone by pressing .

e. Using a voltmeter, carefully measure the voltage at the white hose connector (V). See FIG. 7. See TABLE 8 for the correct voltage reading for your hose length.

Table 8: SCR Circuit Voltage Readings

Hose Length, ft (m)	Reading in Vac
50 (15.2)	20
100 (30.5)	34
150 (45.7)	48
200 (61.0)	62
250 (76.2)	76
300 (91.5)	90

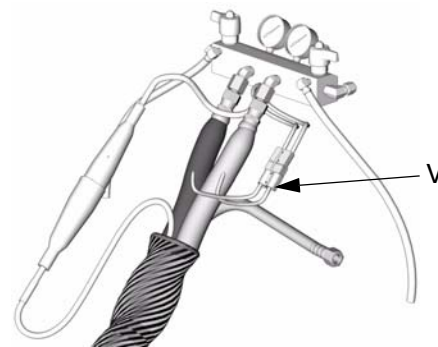



ti2727a

FIG. 7. Test SCR Circuit

2. Test the SCR circuit in the off position:
 - a. Make sure everything is connected, including the hose.

- b. Turn main power ON .

- c. Adjust the hose heat setpoint **below** the ambient hose temperature.

- d. Turn on  heat zone by pressing .

- e. Using a voltmeter, carefully measure the voltage at the white hose connector (V). See FIG. 7. You should not get a voltage reading. If you do, the SCR on the temperature control board is bad. Replace the temperature control board.

Replacing Temperature Control Board

CAUTION
Before handling board, put on a static conductive wrist strap to protect against static discharge which can damage board. Follow instructions provided with wrist strap.

1. Turn main power OFF . Disconnect power supply.

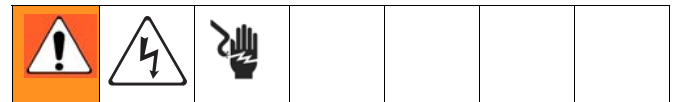

2. Relieve pressure, page 24.
3. Refer to electrical diagrams. Temperature control board is on left side inside cabinet.
4. Put on static conductive wrist strap.
5. Disconnect all cables and connectors from board, FIG. 8.
6. Remove nuts and take entire temperature control assembly to workbench.
7. Remove screws and take board off heatsink.
8. Install new board in reverse order. Apply thermal heatsink compound to mating surfaces of board and heatsink.



Order Part No. 110009 Thermal Compound.

⚠ Apply 110009 thermal heatsink compound to mating surfaces.

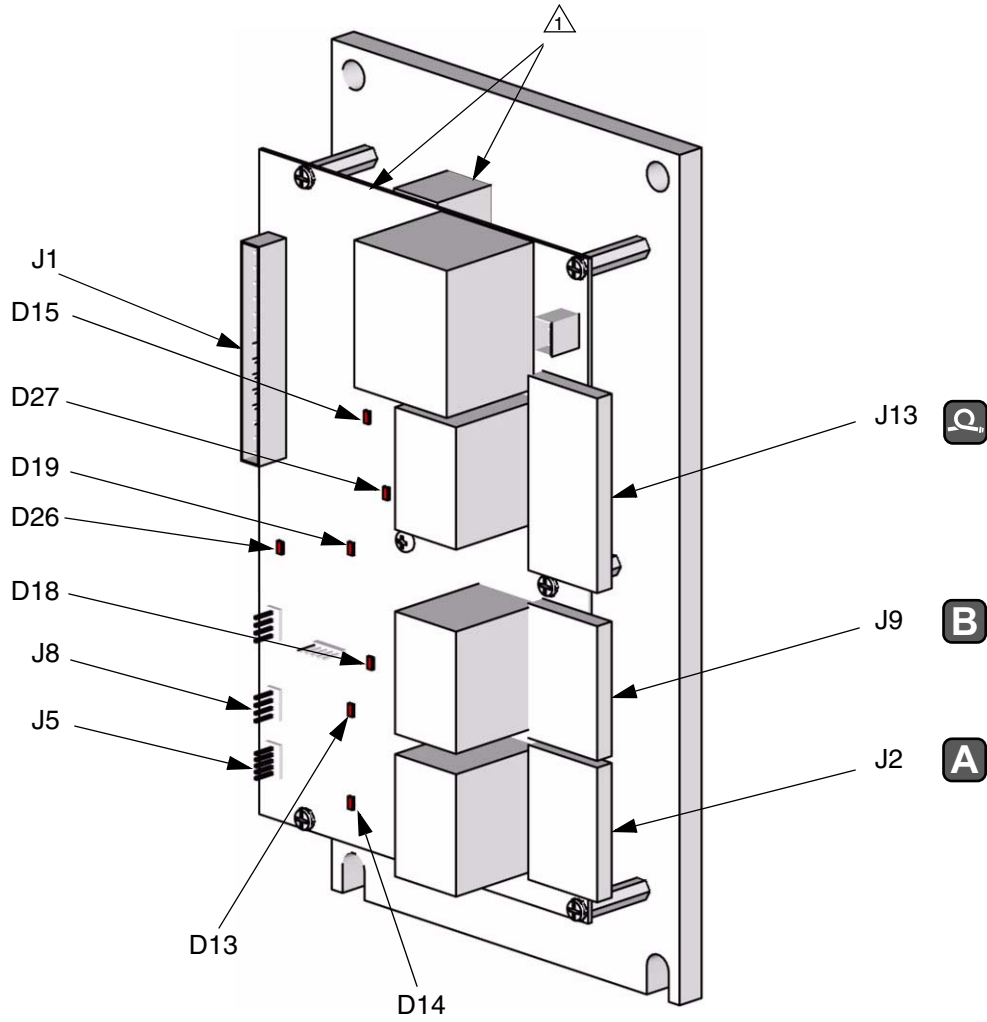

ti2575a

FIG. 8. Temperature Control Board

Primary Heaters

Heater Element



1. Turn main power OFF . Disconnect power supply.
2. Relieve pressure, page 24.
3. Wait for heaters to cool.
4. Remove heater shroud.
5. See FIG. 9. Remove tape and wire nuts (not shown), and disconnect heater element wires (W) from heater wire harness. Test with ohmmeter. Resistance must be 18-21 ohms for 2550W element (used on 7.5 kW heaters), and 23-26 ohms for 2000W element (used on 8.0 kW heaters).
6. To remove heater element, first remove thermocouple (210) to avoid damage, see step 7, page 37.
7. Unscrew heater element (207) from fitting (202). Remove heater element (207) from housing (201). Be careful not to spill any fluid left in housing.
8. Inspect the element. It should be relatively smooth and shiny. If there is a crusted, burnt, ash-like material adhered to the element or the sheath shows pitting marks, replace the element.
9. Apply thread sealant to the heater element threads and install new heater element (207), holding mixer (209) so it does not block thermocouple port (P).
10. Reinstall thermocouple, page 37.
11. Reconnect the heater element leadwires to the wire harness and secure with wire nuts and electrical tape.
12. Replace heater shroud.

Line Voltage

The primary heaters are rated at either 7650 W (single zone, 2 per machine) or 8000 W (dual zone, 1 per machine), at 230 Vac. Low line voltage will reduce power available and the heaters will not perform at full capability.

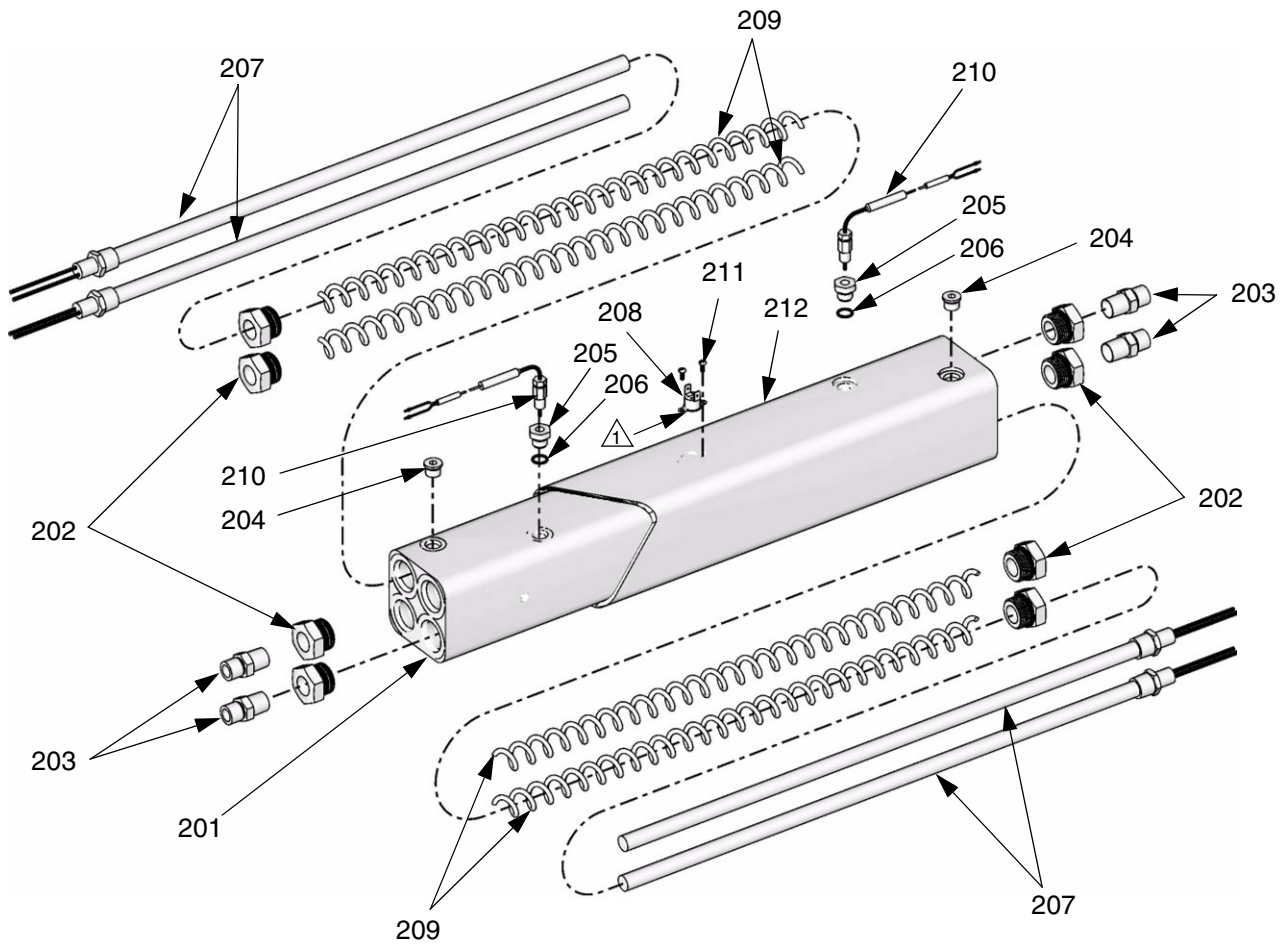

 Apply 110009 thermal heatsink compound.

ti7721a

FIG. 9. Heater (Part No. 253189 8.0 kW Dual Zone Heater Shown)

Thermocouple

1. Turn main power OFF . Disconnect power supply.
2. Relieve pressure, page 24.

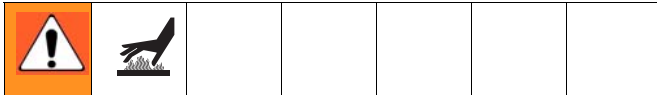

3. Wait for heaters to cool.
4. Remove heater shroud.
5. Disconnect thermocouple wires from J1 on temperature control board. See TABLE 7, page 32 and FIG. 8, page 34.
6. Feed thermocouple wires out of cabinet. Note path as wires must be replaced in the same way.
7. See FIG. 10. Loosen ferrule nut (N). Remove thermocouple (210) from heater housing (201), then remove thermocouple housing (H). Do not remove the thermocouple adapter (205) unless necessary. If adapter must be removed, ensure that mixer (209) is out of the way when replacing the adapter.

8. Replace thermocouple, FIG. 10.
 - a. Remove protective tape from thermocouple tip (T).
 - b. Apply PTFE tape and thread sealant to male threads and tighten thermocouple housing (H) into adapter (205).
 - c. Push in thermocouple (210) so tip (T) contacts heater element (207).
 - d. Holding thermocouple (T) against heater element, tighten ferrule nut (N) 1/4 turn past tight.
9. Route wires (S) into cabinet and thread into bundle as before. Reconnect wires to board.
10. Replace heater shroud.
11. Turn on heaters A and B simultaneously to test. Temperatures should rise at same rate (30°F, +/- 4°). If one heater is low, loosen ferrule nut (N) and tighten thermocouple housing (H) to ensure thermocouple tip (T) contacts element (207).

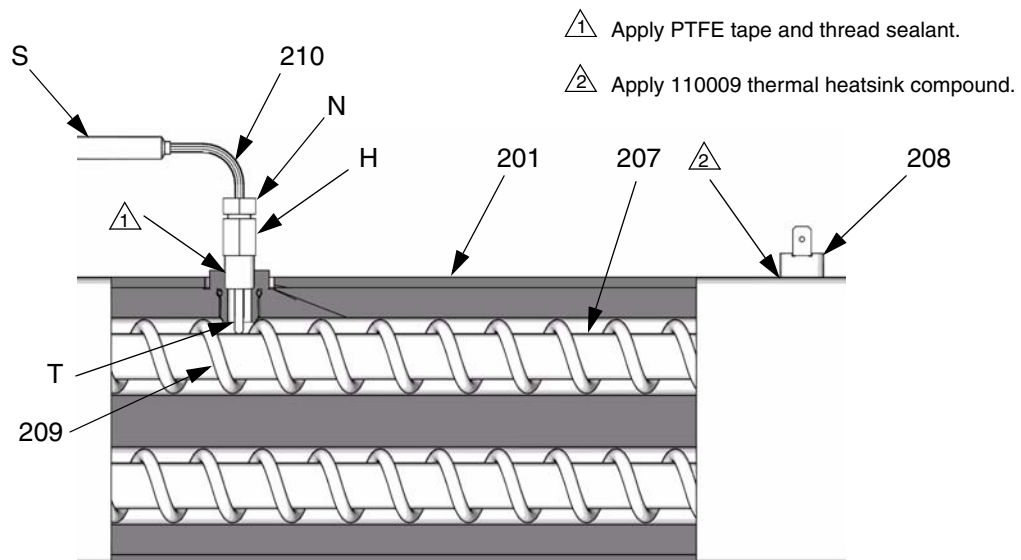

ti7924a

FIG. 10. Thermocouple

Overtemperature Switch

1. Turn main power OFF . Disconnect power supply.
2. Relieve pressure, page 24.



3. Wait for heaters to cool.
4. Remove heater shroud.
5. Disconnect one leadwire from overtemperature switch (208), FIG. 10. Test across switch with ohmmeter. Resistance must be approximately 0 ohms.
6. If switch fails test, remove wires and screws. Discard failed switch. Apply thermal compound 110009, install new switch in same location on housing (201), and secure with screws (211). Reconnect wires.

 If wires need replacement, disconnect from temperature control board. See TABLE 7, page 32 and FIG. 8, page 34.

Heated Hose

 Refer to the heated hose manual 309572 for hose replacement parts.

Check Hose Connectors

1. Turn main power OFF . Disconnect power supply.
2. Relieve pressure, page 24.

 Whip hose must be connected.

3. Disconnect hose electrical connector (D) at Reactor, FIG. 11.
4. Using an ohmmeter, check between the two terminals of hose connector (D). There should be continuity.
5. If hose fails test, retest at each length of hose, including whip hose, until failure is isolated.

Check FTS Cables

1. Turn main power OFF . Disconnect power supply.
2. Relieve pressure, page 24.
3. Disconnect FTS cable (F) at Reactor, FIG. 11.
4. Test with ohmmeter between pins of cable connector.

Pins	Result
1 to 2	approximately 35 ohms per 50 ft (15.2 m) of hose, plus approximately 10 ohms for FTS
1 to 3	infinity

5. If cable fails test, retest at FTS, page 39.

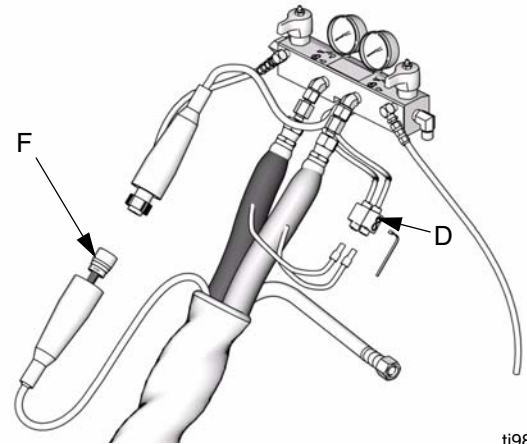

ti9878a

FIG. 11. Heated Hose

Fluid Temperature Sensor (FTS)

Test/Removal

1. Turn main power OFF . Disconnect power supply.
2. Relieve pressure, page 24.
3. Remove tape and protective covering from FTS (11), FIG. 12. Disconnect hose cable (F). Test with ohmmeter between pins of cable connector.

Pins	Result
1 to 2	approximately 10 ohms
1 to 3	infinity
3 to FTS groundscrew	0 ohms
1 to FTS component A fitting (ISO)	infinity

4. If FTS fails any test, replace FTS.
5. Disconnect air hoses (C, L), and electrical connectors (D).
6. Disconnect FTS from whip hose (W) and fluid hoses (A, B).
7. Remove ground wire (K) from ground screw on underside of FTS.
8. Remove FTS probe (H) from component A (ISO) side of hose.

Installation

The Fluid Temperature Sensor (FTS) is supplied. Install FTS between main hose and whip hose. See Heated Hose manual 309572 for instructions.

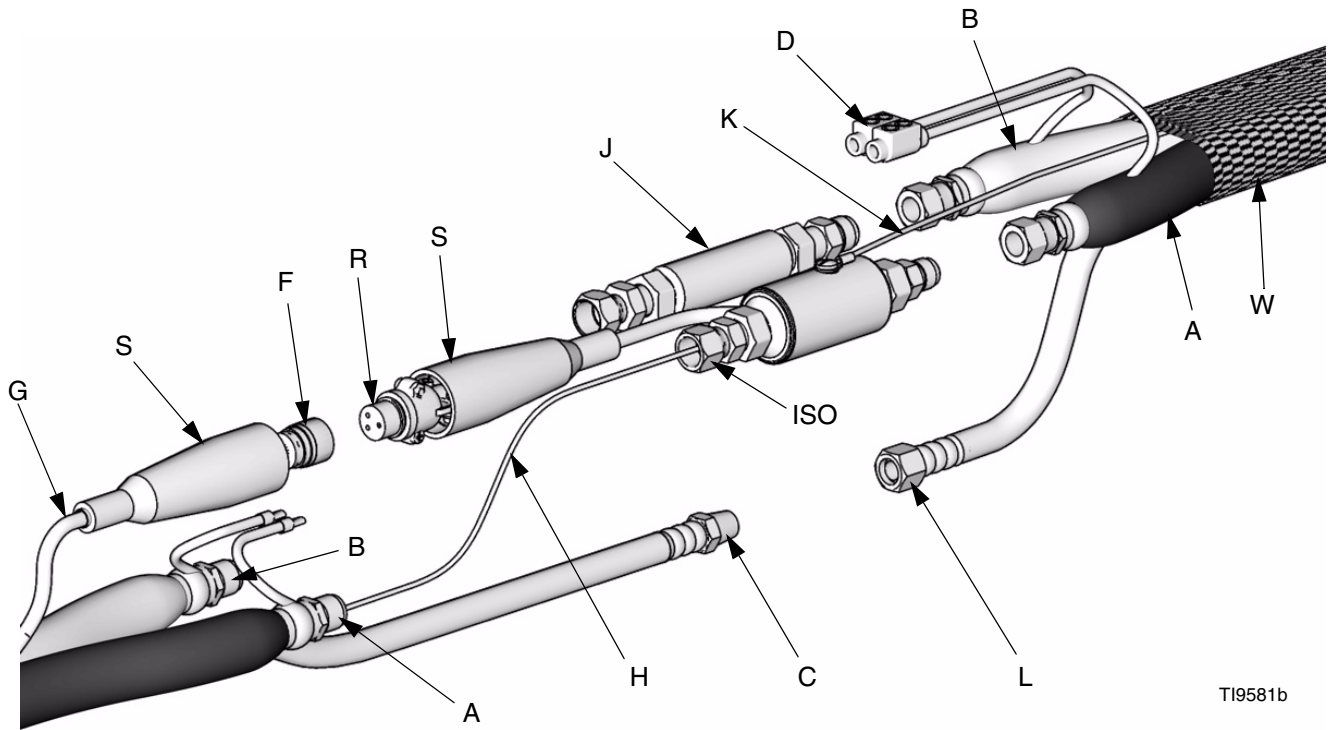

T19581b

FIG. 12. Fluid Temperature Sensor and Heated Hoses

Transformer

Test Hose Continuity

1. Turn main power OFF . Disconnect power supply. Leave hose plugged in.
2. See FIG. 13. Disconnect 6-pin transformer connector (S) from J13 at temperature control board. Remove red wire from transformer hose length tap you are using (R).
3. Using an ohmmeter, check between pin 6 (P6) of connector (not board) and red wire. There should be continuity.
4. If test fails, trace wires until failure is located.

Test Transformer Wire Harness Continuity

1. Turn main power OFF . Disconnect power supply. Leave hose plugged in.
2. See FIG. 13. Disconnect 6-pin transformer connector (S) from J13 at temperature control board.

3. Check for continuity between:
 - a. Connector pin 1 (P1) and T1 on 20A hose circuit breaker (817A).
 - b. Connector pin 3 (P3) and T2 on 20A hose circuit breaker (817A).
 - c. Connector pin 5 (P5) and T3 on 50A hose circuit breaker (806).

Test Current Sensor Continuity

1. Turn main power OFF . Disconnect power supply.
2. Disconnect 14-pin connector from J1 on temperature control board, page 32.
3. Using an ohmmeter, test for continuity across pins 5 and 6 of connector (not board). Reading should be 20-25 ohms. If not, replace current sensor (32). See FIG. 13.

Test In-Rush Current Limiter

Applies to 380V models only.

1. Ensure all harnesses, cables, and connectors are properly connected.
2. Connect main power supply. Turn main power on.
3. Press hose heat button to turn on hose heat.
4. Ensure contactor of in-rush current limiter closes.
5. If contactor does not close, turn off main power and check fuse. If fuse is blown, replace.
6. Turn hose heat on. If contactor still does not close with fuse replaced and hose heat on, perform transformer checks. See page 43.
7. If fuse continually blows, replace in-rush current limiter.

Detail B: Circuit Breaker Module and Hose Heat Wire Harness

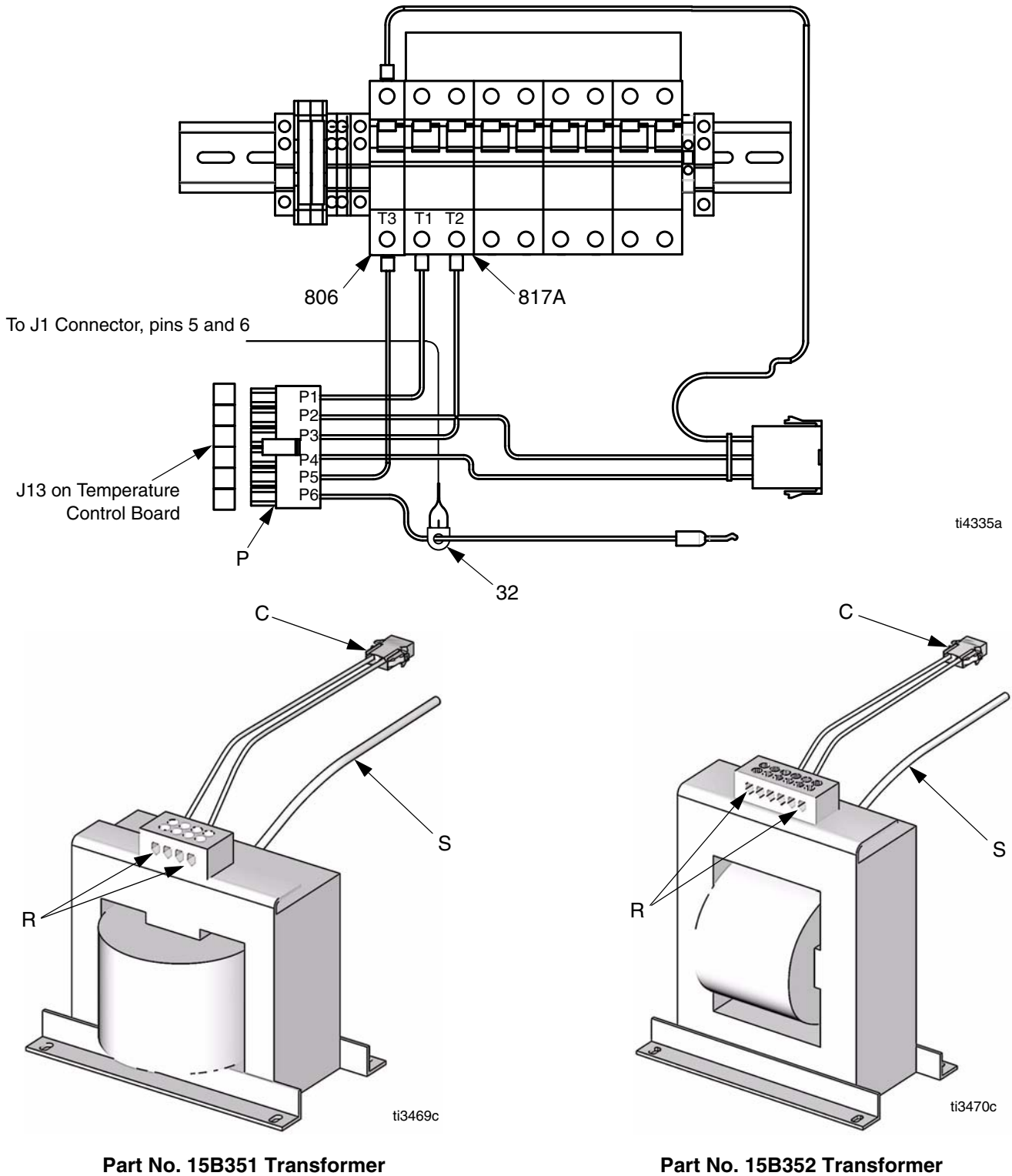

FIG. 13. Transformer Continuity Tests



Transformer Primary Check

1. Ensure that all harnesses, cables, and connectors are properly connected. Connect hose.

2. Connect power supply. Turn main power ON



3. Set hose heat target temperature below current hose temperature.

4. Turn on  heat zone by pressing .

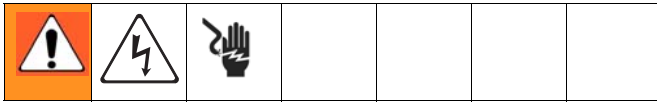

5. See FIG. 13, Detail B. Measure voltage across pins P2 and P4 of six-pin connector on temperature control board. Measurement should be within line voltage specifications, see page 72. If not, replace temperature control board, page 32.



Transformer Secondary Check

1. Ensure that all harnesses, cables, and connectors are properly connected. Connect hose.

2. Connect power supply. Turn main power ON



3. Set hose heat target temperature below current hose temperature.

4. Turn on  heat zone by pressing .

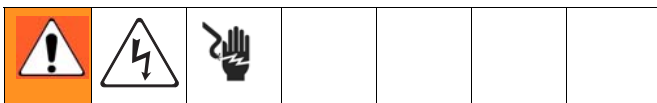



5. See FIG. 14, Detail B. Measure voltage across transformer hose tap (R) you are using and top terminal (T4) on 50A hose circuit breaker (806). See TABLE 9 for readings. If reading is correct, replace temperature control board, page 32. If reading is wrong, replace transformer.

Table 9: Transformer Voltage Readings

Transformer Tap	Reading (VAC)
50'	20
100'	34
150'	48
200'	62
250'	76
300'	90

Replace Transformer

 Use this procedure to replace transformer.

1. Turn main power OFF . Disconnect power supply.

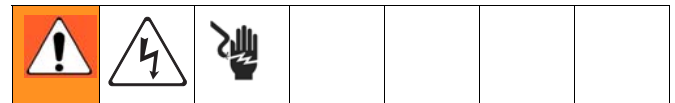

2. Open Reactor cabinet.
3. Remove bolts holding transformer to cabinet floor. Slide transformer forward.
4. Unplug 2-pin wire harness connector (C) from wire harness coming from temperature control board.
5. Disconnect the transformer's secondary common wire (S) from T4 at 50 amp circuit breaker (806).
6. Remove transformer from cabinet.
7. Install new transformer in reverse order.

Detail B: Circuit Breaker Module

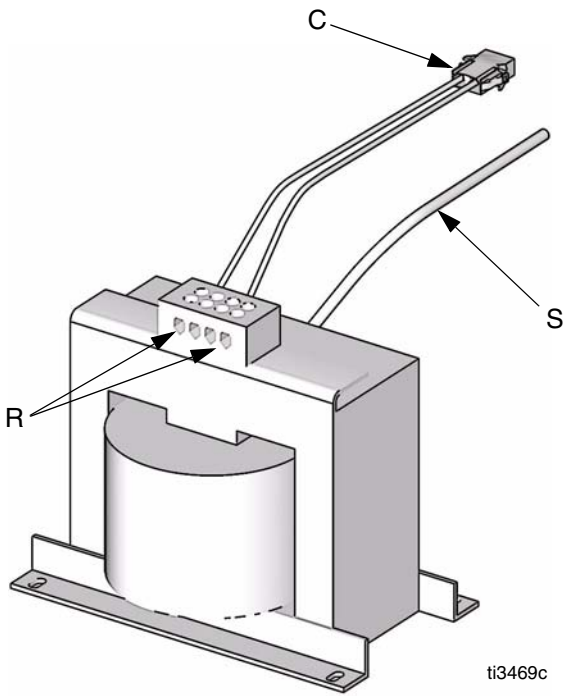
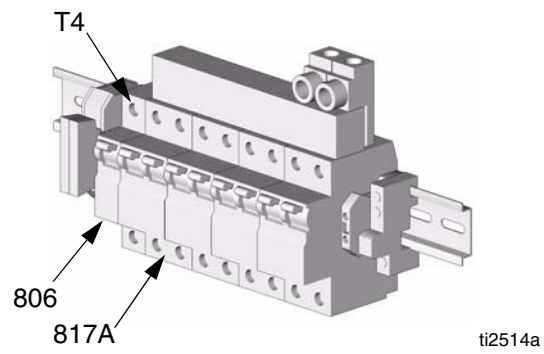

Part No. 15B351 Transformer

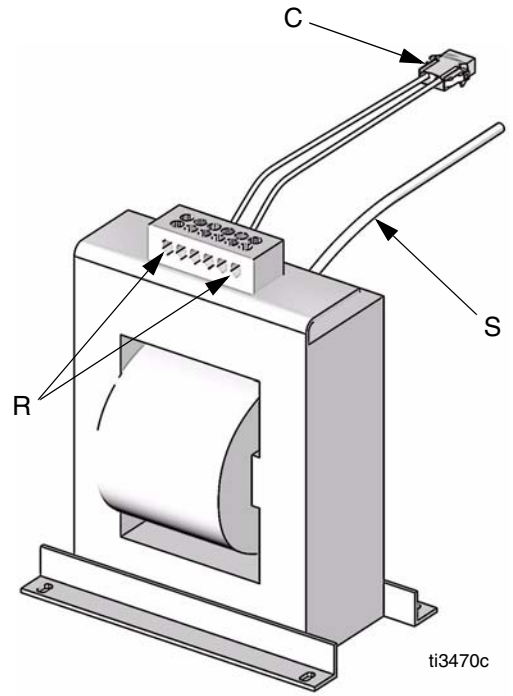

Part No. 15B352 Transformer

FIG. 14. Transformer

Display Module

Temperature and Pressure Displays

CAUTION

Before handling board, put on a static conductive wrist strap to protect against static discharge which can damage board. Follow instructions provided with wrist strap.

1. Turn main power OFF . Disconnect power supply.

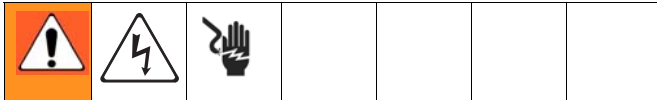

2. Relieve pressure, page 24.
3. Refer to electrical diagrams.
4. Put on static conductive wrist strap.
5. Disconnect main display cable (20) at lower left corner of display module, FIG. 15.
6. Remove screws (409, 410) and cover (404).

 If replacing both displays, label temperature display cables TEMP and pressure display cables PUMP before disconnecting.

7. Disconnect cable connectors J1 and J13 from back of temperature display (401) or pressure display (402).
8. Disconnect ribbon cable(s) (R) from back of display.
9. Remove nuts (408) and plate (405).
10. Disassemble display, see detail in FIG. 15.
11. Replace board (401a or 402a) or membrane switch (401b or 402b) as necessary.
12. Reassemble in reverse order, see FIG. 15. Apply medium strength thread sealant where shown. Be sure display cable ground wire (G) is secured between cable bushing and cover (404) with screws (412).

Red Stop Button

CAUTION

Before handling board, put on a static conductive wrist strap to protect against static discharge which can damage board. Follow instructions provided with wrist strap.

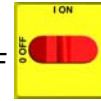

1. Turn main power OFF . Disconnect power supply.
2. Relieve pressure, page 24.
3. Refer to electrical diagrams.
4. Put on static conductive wrist strap.
5. Remove screws (409, 410) and cover (404), FIG. 15.
6. Disconnect button cable connectors J1 from back of temperature display (401) and pressure display (402).
7. Remove red stop button (406).
8. Reassemble in reverse order. Be sure display cable ground wire (G) is secured between cable bushing and cover (404) with screws (412).

 Apply medium strength thread sealant.

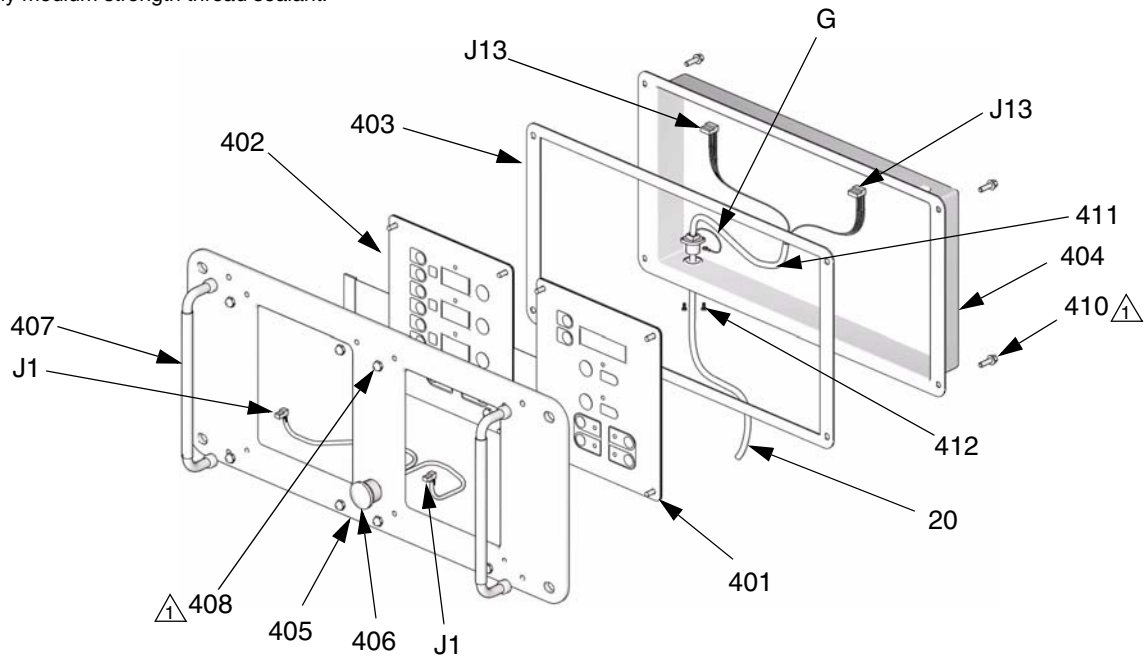

ti2574a

Detail of Membrane Switches and Display Boards

Temperature Display

Pressure Display

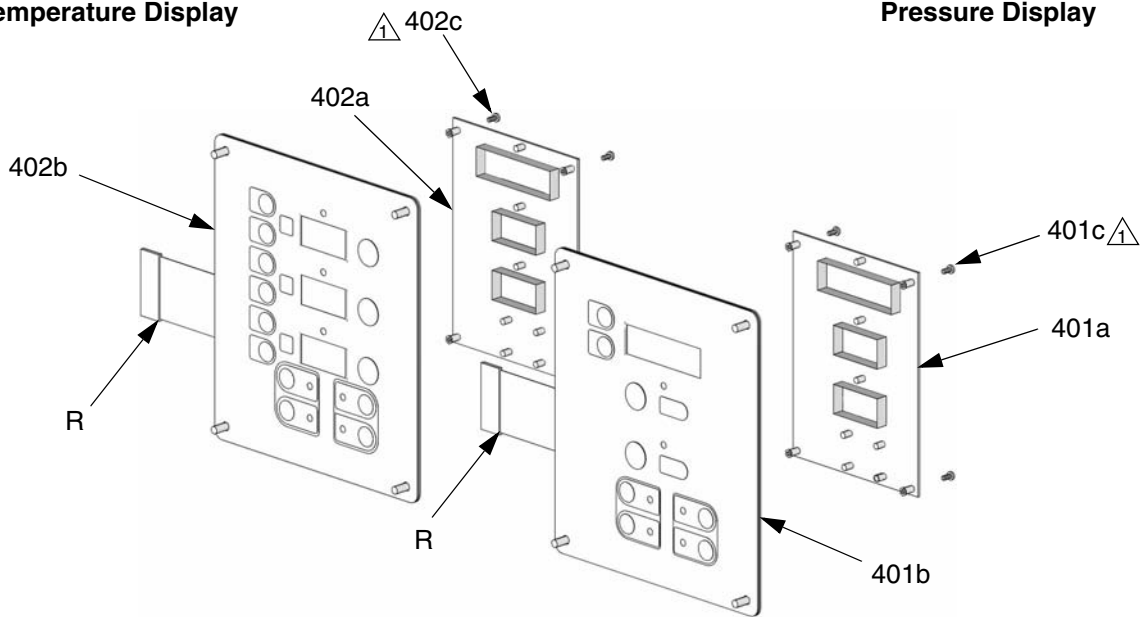

ti3172a

FIG. 15. Display Module

Inlet Fluid Strainer Screen

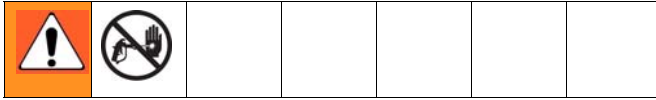

The inlet strainer at each proportioning pump filters out solid matter that can plug the inlet check valves. Inspect the screens daily as part of the startup routine, and clean as required.

Isocyanate can crystallize from moisture contamination or from freezing. If the chemicals used are clean and proper storage, transfer, and operating procedures are followed, there should be minimal contamination of the A-side screen.

 Clean the A-side screen only during daily startup. This minimizes moisture contamination by immediately flushing out any isocyanate residue at the start of dispensing operations.

1. Close the material supply valve at the pump inlet and shut off the hydraulic supply to the appropriate proportioning pump. This prevents material from being pumped while the strainer plug (59j) is removed.
2. Place a container under the strainer base to catch drain off when removing the strainer plug.
3. Remove the screen (59g) from the strainer manifold. Thoroughly flush the screen with gun cleaner and shake it dry. Inspect the screen for blockage. No more than 25% of the mesh should be restricted. If more than 25% is blocked, replace the screen. Inspect the strainer gasket (59h) and replace as required.
4. Ensure the pipe plug (59k) is securely screwed into the strainer plug (59j). Install the strainer plug with the screen (59g) and gasket (59h) in place and tighten. Do not overtighten. Let the gasket make the seal.
5. Open the material supply valve, ensure that there are no leaks, and wipe the equipment clean.
6. Proceed with operation.

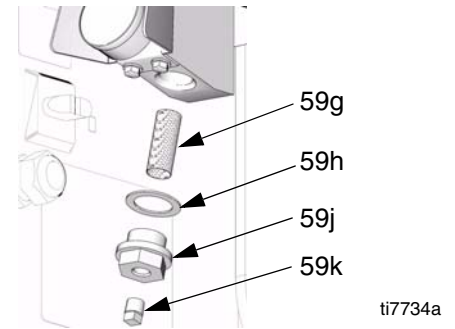

FIG. 16. Y Strainer Components

Pump Lubrication System



Check the condition of the ISO pump lubricant daily. Change the lubricant if it becomes a gel, its color darkens, or it becomes diluted with isocyanate.

Gel formation is due to moisture absorption by the pump lubricant. The interval between changes depends on the environment in which the equipment is operating. The pump lubrication system minimizes exposure to moisture, but some contamination is still possible.

Lubricant discoloration is due to continual seepage of small amounts of isocyanate past the pump packings during operation. If the packings are operating properly, lubricant replacement due to discoloration should not be necessary more often than every 3 or 4 weeks.

To change pump lubricant:

1. Relieve pressure, page 24.
2. Lift the lubricant reservoir (LR) out of the bracket (RB) and remove the container from the cap. Holding the cap over a suitable container, remove the check valve and allow the lubricant to drain. Reattach the check valve to the inlet hose. See FIG. 17.
3. Drain the reservoir and flush it with clean lubricant.
4. When the reservoir is flushed clean, fill with fresh lubricant.
5. Thread the reservoir onto the cap assembly and place it into the bracket.

6. Push the larger diameter supply tube (ST) approximately 1/3 of the way into the reservoir.
7. Push the smaller diameter return tube (RT) into the reservoir until it reaches the bottom.

Important: The return tube (RT) must reach the bottom of the reservoir, to ensure that isocyanate crystals will settle to the bottom and not be siphoned into the supply tube (ST) and returned to the pump.

8. The lubrication system is ready for operation. No priming is required.

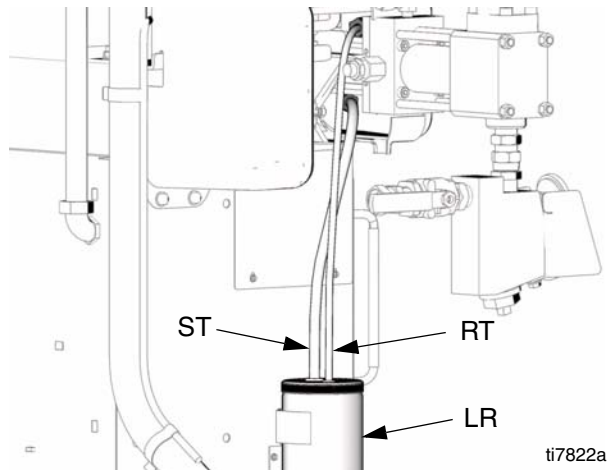
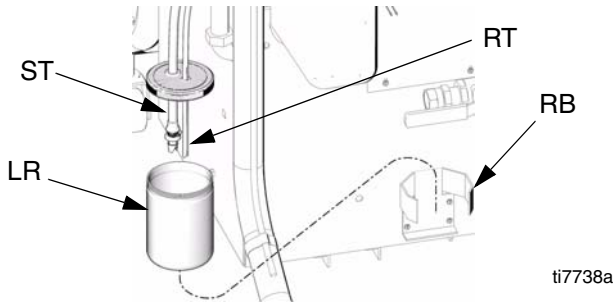

FIG. 17. Pump Lubrication System

Change Hydraulic Fluid and Filter



See TABLE 10 for recommended frequency of oil changes.

Change the break-in oil in a new unit after the first 250 hours of operation or within 3 months, whichever comes first.

Table 10: Frequency of Oil Changes

Ambient Temperature	Recommended Frequency
0 to 90°F (-17 to 32°C)	1000 hours or 12 months, whichever comes first
90°F and above (32°C and above)	500 hours or 6 months, whichever comes first

1. Relieve pressure, page 24.
2. Allow the hydraulic fluid to cool.
3. Remove the cover plate (152) from the left side of the unit.
4. Place a pan under the reservoir drain tube (12aa) to catch the oil. See FIG. 18.
5. Hold the drain tube (12aa) with a pipe wrench to prevent it from turning in the elbow (12z), and remove the drain cap (12ab).
6. Place a rag around the base of the oil filter (12t), to prevent oil from spilling. Unscrew the filter.
7. Clean the reservoir drain tube and cap threads. Reapply PTFE tape and pipe sealant.

Continued on page 49.

8. Hold the drain tube (12aa) with a pipe wrench to prevent it from turning in the elbow (12z), and reinstall the drain cap (12ab) on the reservoir drain tube.
9. Replace the filter (12t):
 - a. Coat the filter seal with fresh oil.
 - b. Screw filter on snug, then an additional 1/4 turn.
10. Refill reservoir with approved hydraulic fluid. See TABLE 11.
11. Proceed with normal operation.

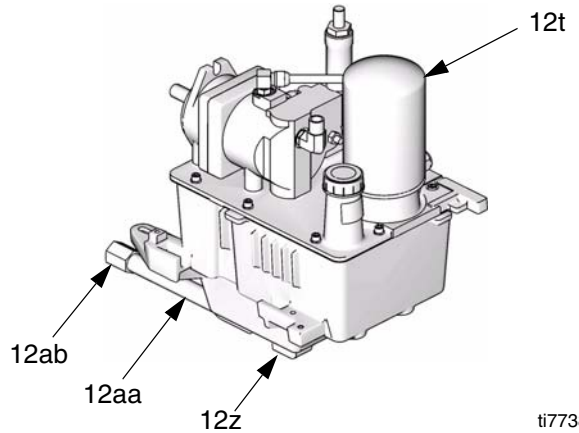

ti7738a

FIG. 18. Change Hydraulic Fluid and Filter

Upon starting motor, the hydraulic pump may make a screeching noise until primed. If this noise continues for more than 30 seconds, switch off the motor control. See **Hydraulic Drive System**, page 20.

Table 11: Approved Anti-Wear (AW) Hydraulic Oils

Supplier	Name
Citgo	A/W ISO Grade 46
Amsoil	AWI ISO Grade 46 (synthetic*)
BP Oil International	Energol [®] HLP-HM, ISO Grade 46
Carl Bechem GmbH	Staroil HVI 46
Castrol	Hyspin AWS 46
Chevron	Rykon [®] AW, ISO 46
Exxon	Humble Hydraulic H, ISO Grade 46
Mobil	Mobil DTE 25, ISO Grade 46
Shell	Shell Tellus, ISO Grade 46
Texaco	Texaco AW Hydraulic, ISO Grade 46
* Note: Do not mix mineral-based and synthetic hydraulic oils. Completely drain oil from reservoir and pump prior to converting between oils.	
If the approved oils are not available in your area, use an alternative hydraulic oil meeting the following requirements:	
Oil Type:	Anti-Wear (AW) Hydraulic
ISO Grade:	46
Viscosity, cSt at 40°C:	43.0-47.0
Viscosity, cSt at 100°C:	6.5-9.0
Viscosity Index:	95 or higher
Pour Point, ASTM D 97:	-15°F (-26°C) or lower
Other essential properties:	Formulated for anti-wear, anti-foaming, oxidation stability, corrosion protection, and water separation

Parts

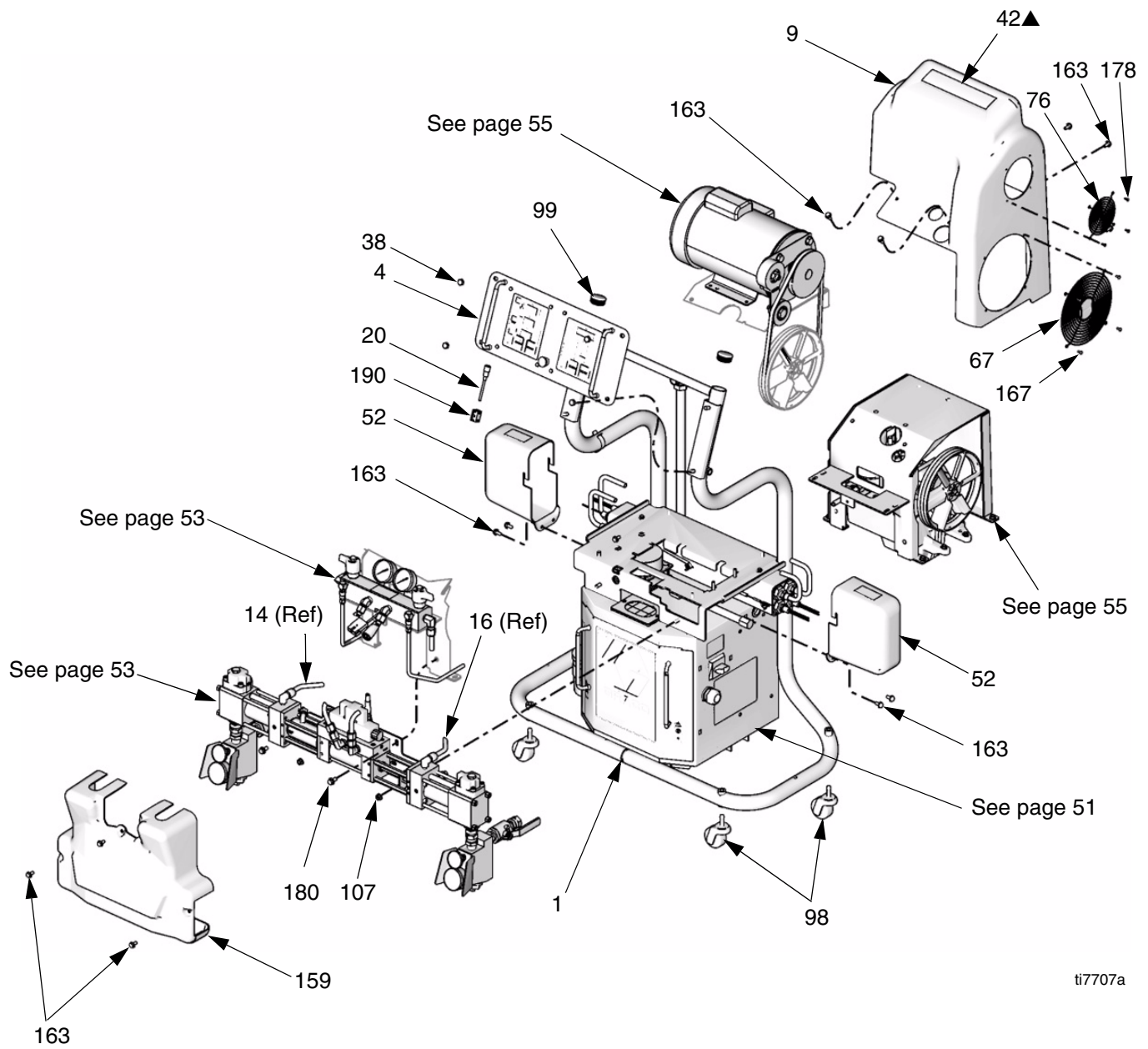

ti7707a

Detail of Cabinet Area

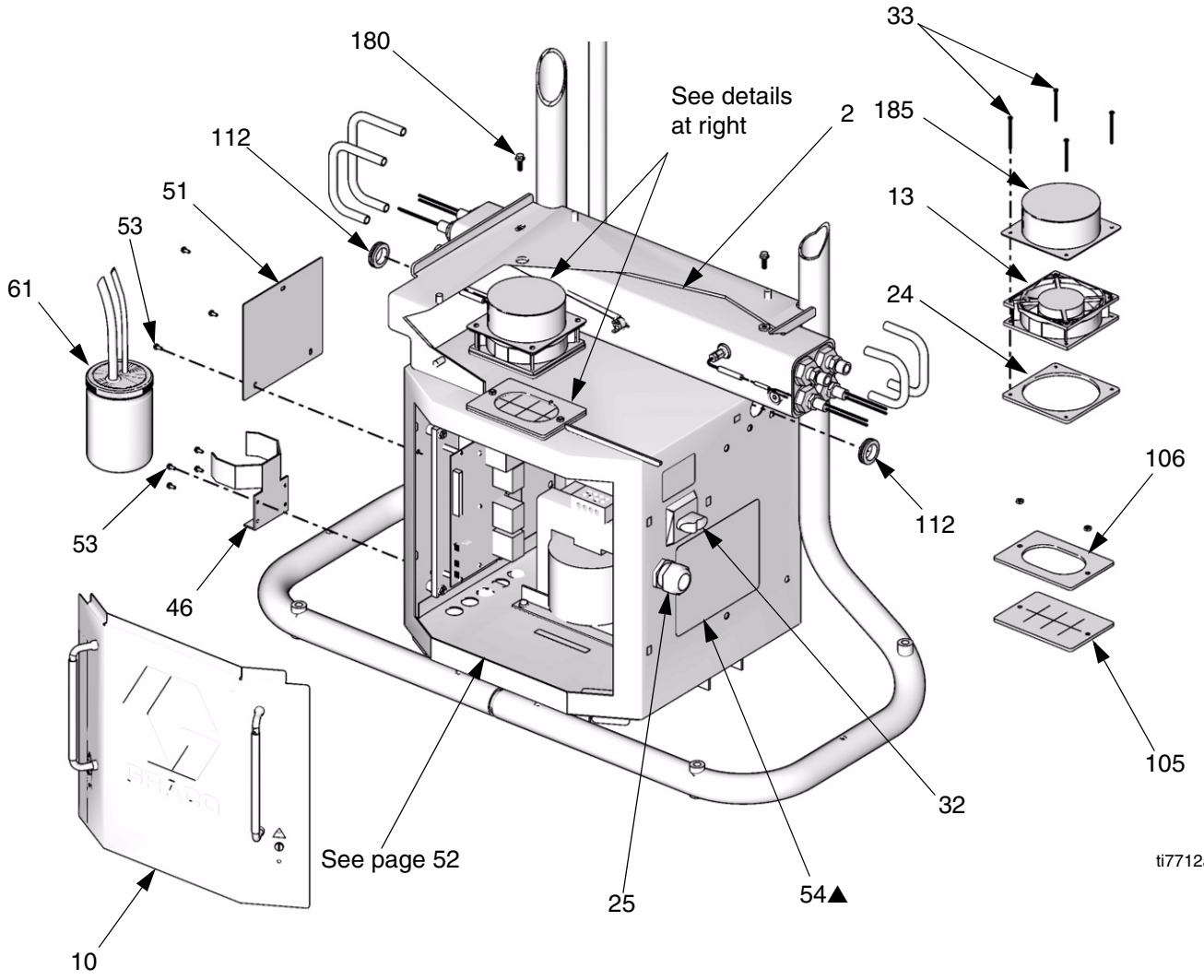

ti7712a

Left Side of Cabinet

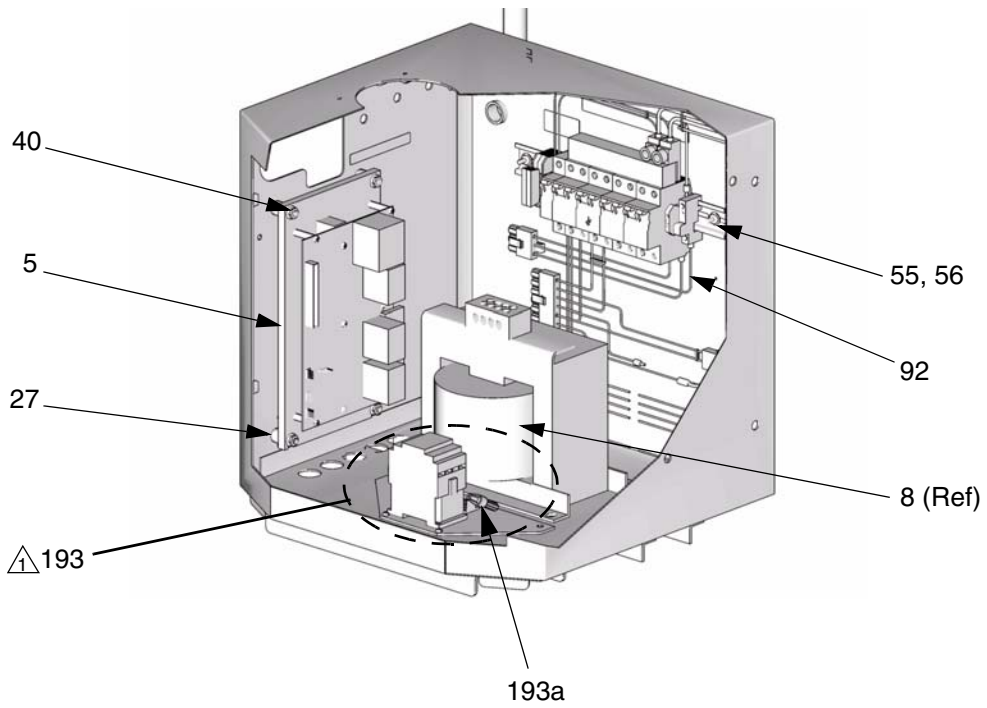

ti9638a

 380V models only

Right Side of Cabinet

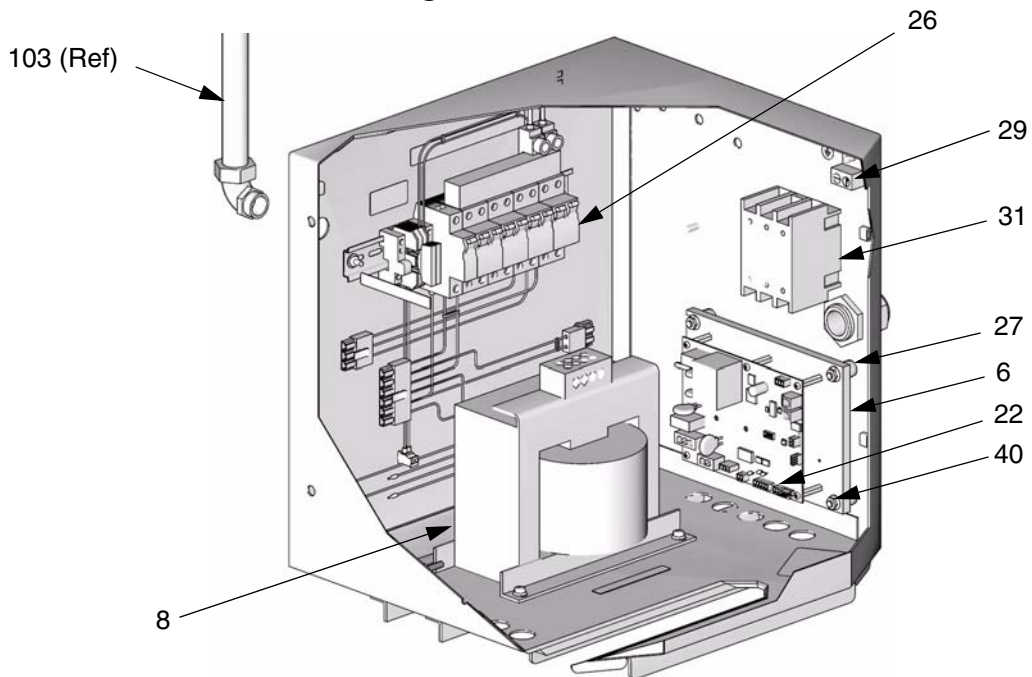

ti7714a

Detail, Fluid Manifold Area

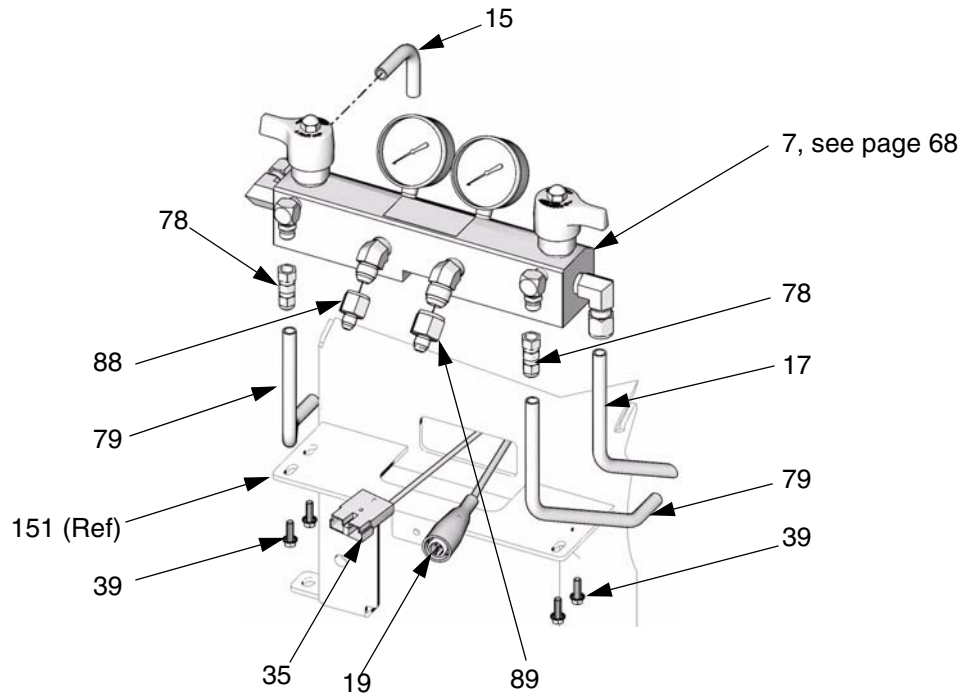

ti7710a

Detail, Proportioner Area

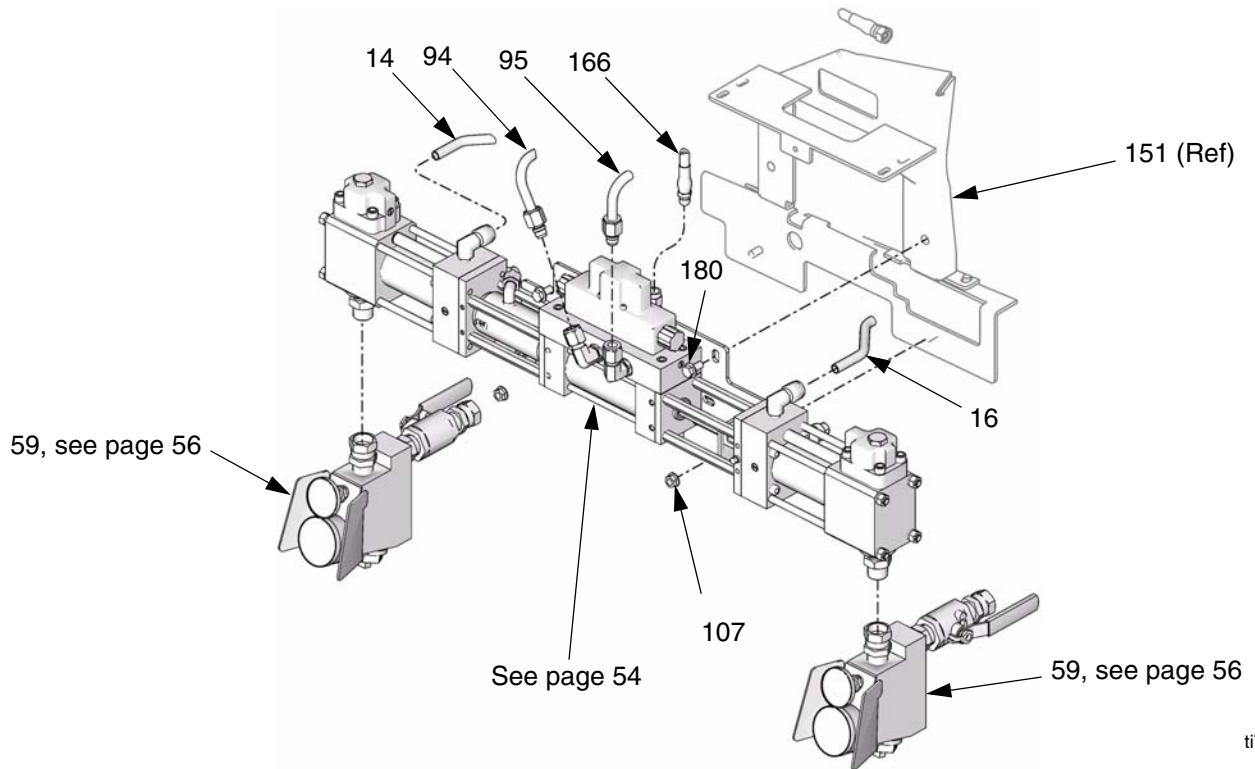

ti7708a

Proportioner Assembly

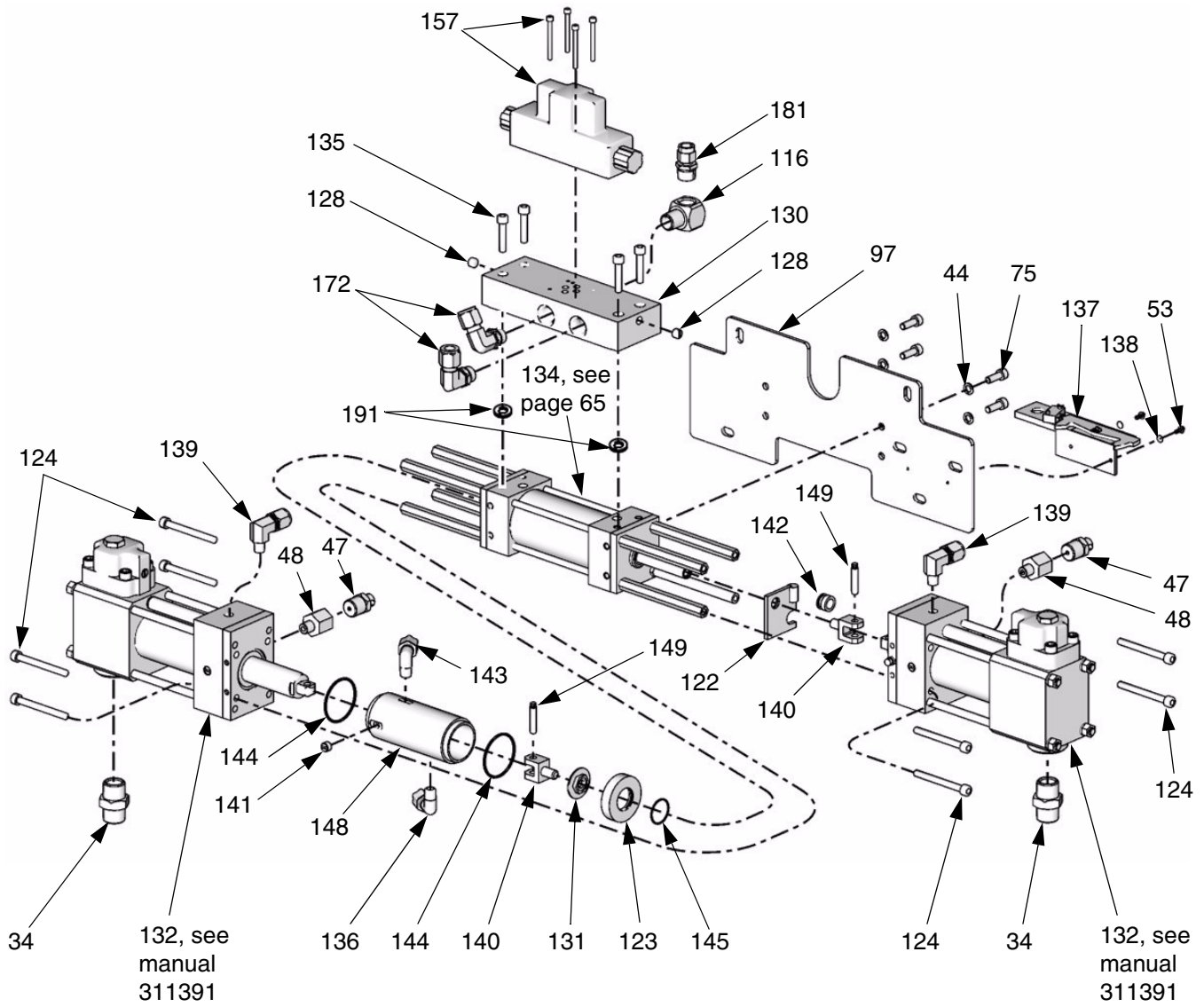

ti7728a

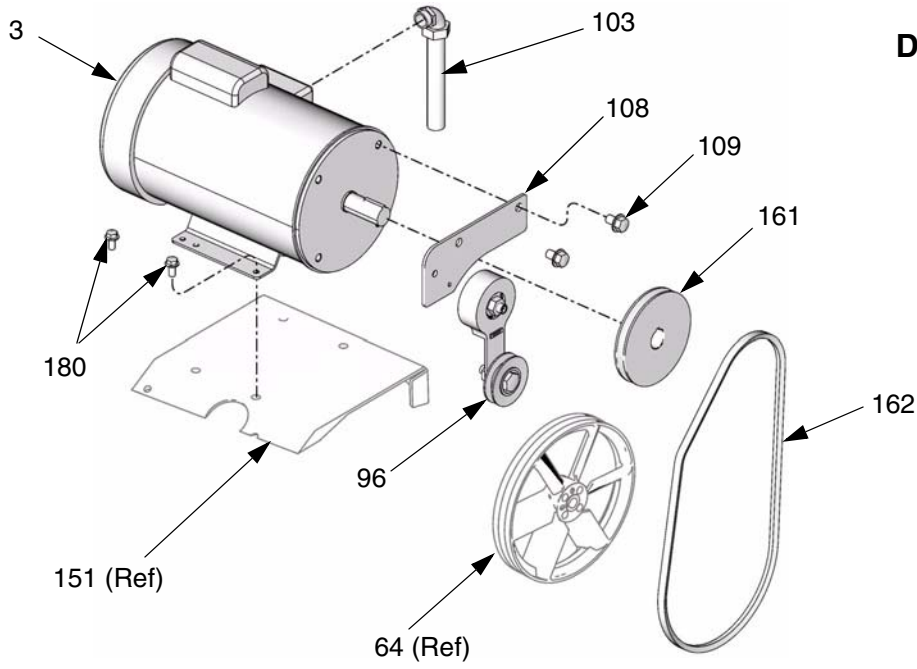

Detail, Electric Motor Area

ti7709a

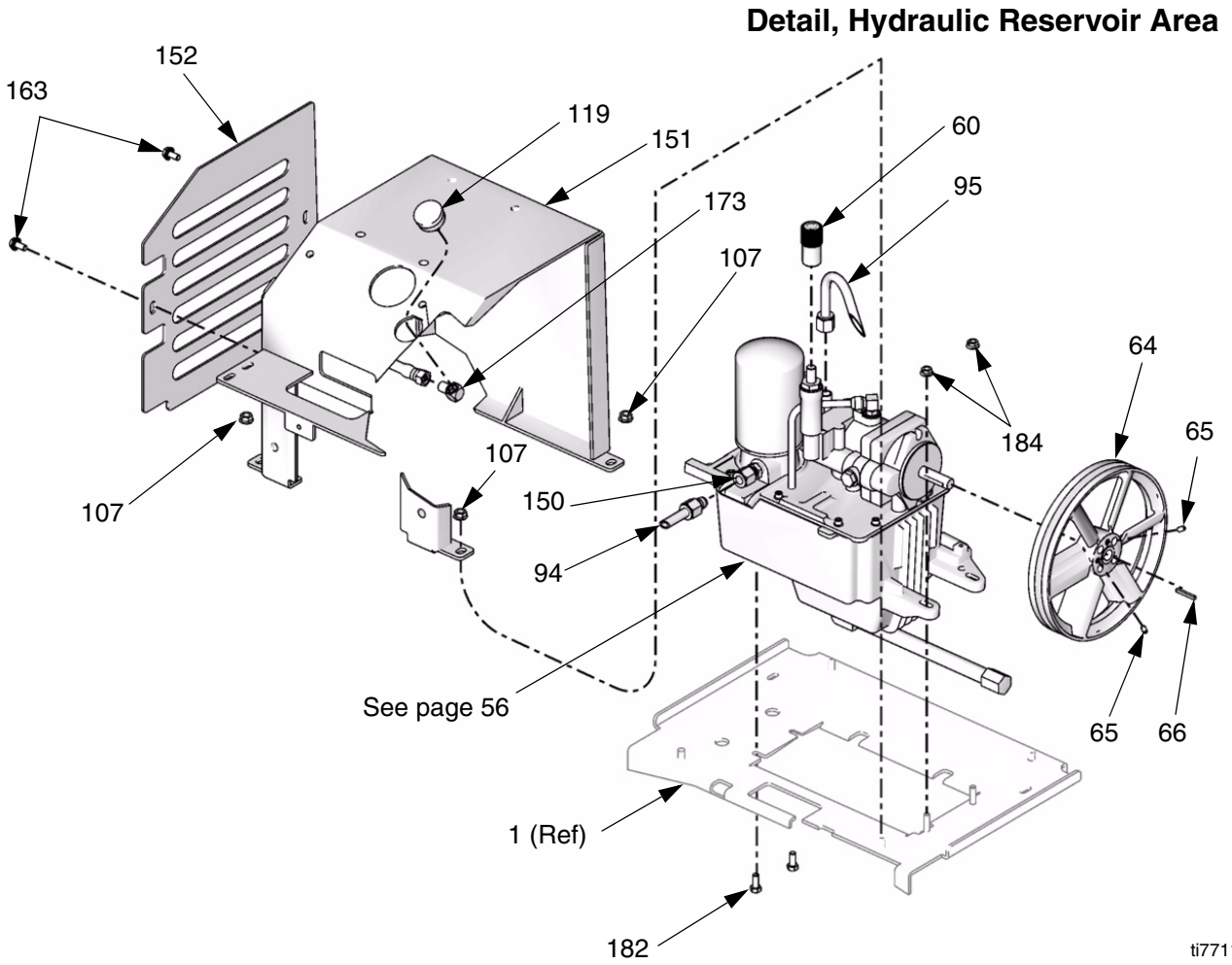

Detail, Hydraulic Reservoir Area

ti7711a

Ref. No. 59, Fluid Inlet Kit

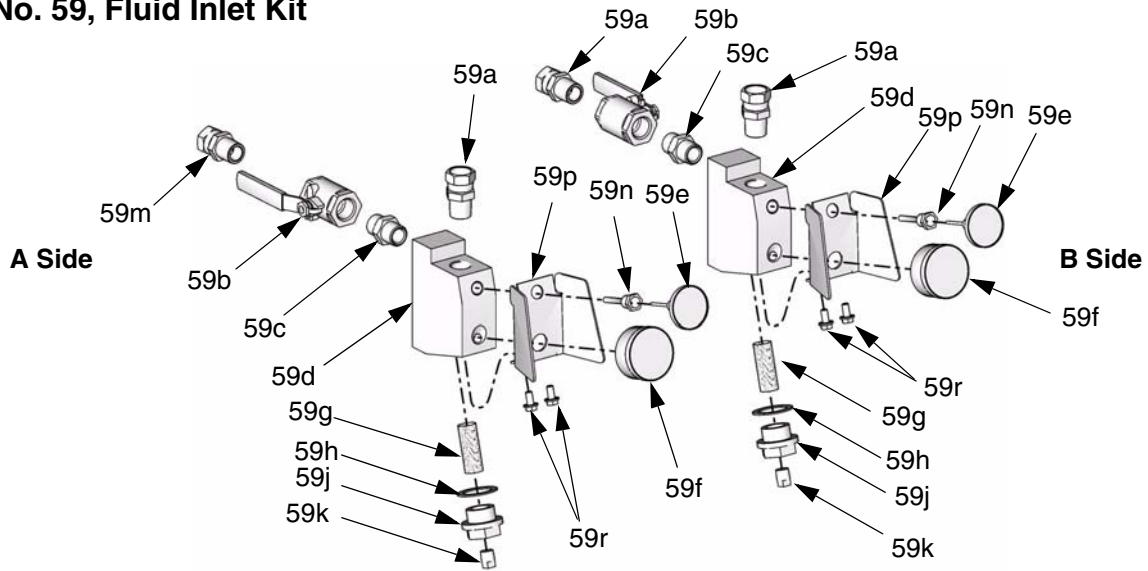

ti7719a

Ref. No. 12, Hydraulic Reservoir

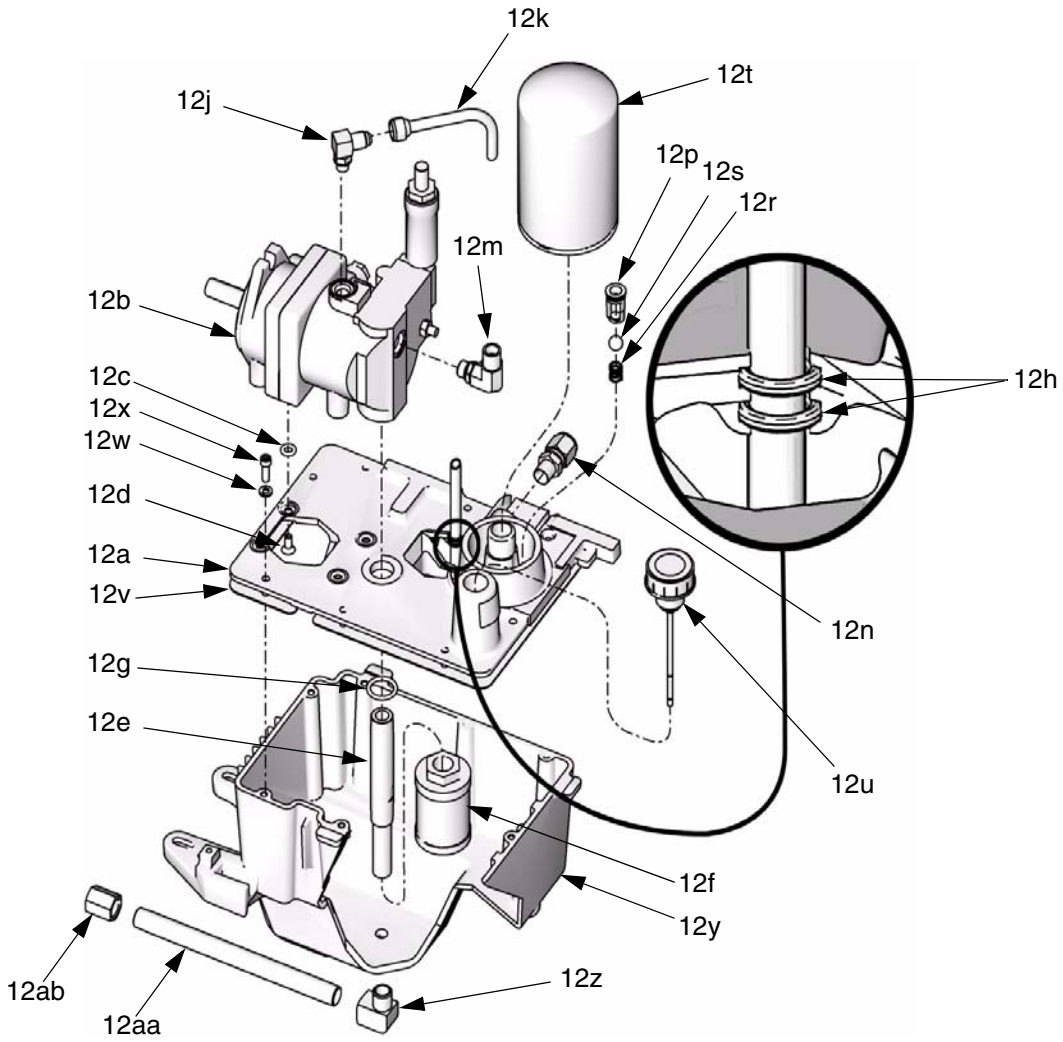

ti7717a

Parts Used on All Models

Pages 57-59 list parts used on all models. Pages 60-62 list parts that vary by model.

Ref. No.	Part No.	Description	Qty.	Ref. No.	Part No.	Description	Qty.
1	253184	CART	1	13	115834	FAN	1
2		HEATER; see pages 59-62 for part numbers		14		TUBE, inlet, component A; see pages 59-62 for part numbers	
3	15H192	MOTOR; 230 V; 4 hp	1	15		TUBE, outlet, component A; see pages 59-62 for part numbers	
4	245974	DISPLAY; page 66	1	16		TUBE, inlet, component B; see pages 59-62 for part numbers	
5	245979	CONTROL, temperature; page 67	1	17		TUBE, outlet, component B; see pages 59-62 for part numbers	
6	253221	CONTROL, motor	1	18	15G792	CABLE, overtemperature; not shown, see electrical diagrams	1
7	246154	MANIFOLD, fluid; page 68	1	19	15B380	CABLE, hose control; not shown, see electrical diagrams	1
8		TRANSFORMER; see pages 59-62 for part numbers		20	15B383	CABLE, display	1
9	253195	COVER, motor	1	21	117555	CONNECTOR, tube; 1/4 npt x 1/2 in. (13 mm) OD tube	2
10	246976	DOOR, cabinet	1	22	116773	CONNECTOR, plug	1
11	261669	SENSOR, fluid temperature	1	23		WASHER, spring lock; #6	1
12	253188	RESERVOIR, hydraulic; includes items 12a-12ab; see page 56	1	24	15B360	GASKET, fan	1
12a	15C676	. COVER, reservoir	1	25	117682	STRAIN RELIEF	1
12b*		. PUMP, hydraulic	1	26		MODULE, breaker; see pages 59-62 for part numbers	
12c*	107188	. O-RING	4	27	116149	SPACER	8
12d	117471	. SCREW, machine, flat hd; 1/4-20	4	29	117666	TERMINAL, ground	1
12e	15E587	. TUBE, suction	1	30	15B388	SENSOR, current, hose; not shown, see electrical diagrams	1
12f	116919	. FILTER, hydraulic	1	31	117564	SWITCH, disconnect	1
12g*	156401	. O-RING	1	32	117545	SWITCH, main power	1
12h	154594	. O-RING	2	33		SCREW, machine; 6-32 x 2 in. (51 mm)	4
12j	110792	. ELBOW	1	34		NIPPLE; 3/4 npt	2
12k	198699	. TUBE, drain	1	35	15B396	WIRE, hose	1
12m	120309	. ELBOW	1	36		SCREW, machine; 8-32 x 0.345 in. (9 mm)	13
12n	117594	. FITTING, straight; 3/8 npt(m) x 1/2 in. (13 mm) OD tube	1	37		INSULATOR, heat; see pages 59-62 for part numbers	
12p	198841	. RETAINER, ball	1	38		NUT, cap; 3/8-16	4
12r	116967	. SPRING	1	39		SCREW, flanged, hex hd; 1/4-20 x 3/4 in. (19 mm)	15
12s	100084	. BALL	1	40		NUT, hex flange; 1/4-20	15
12t	246173	. FILTER, oil	1				
12u	116915	. DIPSTICK, with breather cap	1				
12v*	15A697	. GASKET	1				
12w*	100016	. WASHER, lock	8				
12x*	112166	. SCREW, cap, socket hd	8				
12y	15H738	. TANK	1				
12z		. ELBOW; 1/2 npt (m x f)	1				
12aa		. TUBE, drain; 1/2 npt; 10 in. (254 mm)	1				
12ab		. CAP, drain; 1/2 npt(f)	1				

* These parts are included in Hydraulic Pump Replacement Kit 253573.

Parts

Ref. No.	Part No.	Description	Qty.	Ref. No.	Part No.	Description	Qty.
42▲	15B536	LABEL, status codes	1	60*	15H204	KNOB, pressure	1
44		WASHER, lock; 5/16	4	61	296731	RESERVOIR, lube hose assembly	1
45▲	189930	LABEL, warning	3	64	15E410	PULLEY, fan	1
46	297216	BRACKET, reservoir, lube	1	65		SCREW, set; 1/4 x 1/2 (13 mm)	2
47	248187	RUPTURE DISK KIT; see 309969	2	66		KEY, square; 3/16 x 1-1/4 in.	1
48		ADAPTER; 1/4 npt(m) x 1/2 npt(f)	2	67	117284	GUARD, fan	1
49	15B593	SHIELD, membrane switch; pack of 10	1	68	112512	FERRULE, wire; orange	2
51	15B775	COVER, wire access	2	74	206995	THROAT SEAL LIQUID; 1 quart; not shown	1
52		COVER, heater; see pages 59-62 for part numbers		75		SCREW, cap, socket hd; 5/16-18 x 7/8 in. (22 mm)	4
53		SCREW, machine, hex washer hd; 8-32 x 3/8 in. (10 mm)	9	76	115836	GUARD, finger	1
54▲	15G280	LABEL, warning	1	77	186494	CLIP, spring	5
55		NUT, keps; hex hd; 10-24	6	78	205447	COUPLING, hose	2
56		WASHER, plain; #10 x 0.56 in. (14 mm)	2	79	054826	TUBE; PTFE; 1/4 in. (6 mm) ID; 8 ft (2.4 m)	1
57	117722	CONNECTOR, wire, screw-on	4	88	117502	FITTING, reducer; #5 x #8 JIC	1
58		STRAP, wire tie	20	89	117677	FITTING, reducer; #6 x #10 JIC	1
59	253149	KIT, inlet, fluid; includes items 59a-59r, for A and B sides; see page 56	1	92	15B511	CABLE, power	1
59a		. UNION, swivel; 3/4 npt(m) x 3/4 npsm(f)	3	94	15H160	TUBE, hydraulic, return; sst	1
59b		. VALVE, ball; 3/4 npt (fbe)	2	95	15H161	TUBE, hydraulic, pressure; sst	1
59c		. NIPPLE; 3/4 npt	2	96	120298	ADJUSTER, belt tensioner	1
59d	15H198	. MANIFOLD, strainer, inlet	2	97	253186	BRACKET, mounting, pump	1
59e	102124	. DIAL, temperature, fluid	2	98	120302	CASTER	4
59f	120300	. GAUGE, pressure, fluid	2	99	112125	PLUG, tube	2
59g	180199	. ELEMENT, filter; 20 mesh	2	101	15H184	WIRE, bidirectional cable	1
59h	15H200	. GASKET, strainer; PTFE	2	102	15H185	WIRE, mechanical switch cable	1
59j	15H199	. PLUG, strainer	2	103	15H186	CONDUIT, assembly, motor power	1
59k		. PLUG, pipe; 3/8 npt	2	105	15H189	BOOT, wire, feed through	1
59m		. UNION, swivel; 3/4 npt(m) x 1/2 npt(f); A side only	1	106	15G816	COVER, plate, wire way	1
59n	15D757	. HOUSING, thermometer	2	107		NUT, hex, flanged; 3/8-16	6
59p	15H458	. GUARD, gauge	2	108	253183	BRACKET, tensioner	1
59r		. SCREW, cap, hex hd; 5/16-18 x 5/8 in. (16 mm)	4	109		SCREW, cap, hex hd; 1/2-13 x 3/4 in. (19 mm)	2
				111▲	189285	LABEL, warning	1
				112	114269	GROMMET, rubber	2
				116		ELBOW; 1/2 npt (m x f)	1
				117	295229	FITTING, grease 1/4-28	2
				118	M70430	SCREW, set socket (1/4-28 x .19)	1

▲ Replacement Danger and Warning labels, tags, and cards are available at no cost.

* These parts are included in Hydraulic Pump Replacement Kit 253573.

Ref. No.	Part No.	Description	Qty.	Ref. No.	Part No.	Description	Qty.
119	120301	GAUGE, pressure, fluid, panel mount	1	157	120299	VALVE, directional, hydraulic; includes 10-24 x 1.75 in. (44 mm) screws and o-rings	1
121	C20145	O-RING; buna-N	2	159	253193	COVER, front	1
122	295855	PLATE, activator	1	161	15H256	PULLEY, drive	1
123	298111	PLATE, adapter, lube cylinder	1	162	803889	BELT	1
124		SCREW, cap, socket hd; 5/16-24 x 3 in. (76 mm)	8	163		SCREW; see pages 59-62 for qty	
128	295225	PLUG, pipe, flush; 1/4-18 npt	2	165		SWITCH, added pole; see pages 59-62 for part numbers; 380V units only	
130	298040	MANIFOLD, hydraulic	1	166	15H253	HOSE, gauge, hydraulic	1
131	295852	NUT, jam, baffle	1	167		RIVET, pop; 3/16 in. (5 mm) x 0.4 in. (10 mm)	4
132		PUMP, proportioning; see pages 59-62 for part numbers		170		BRACKET, heater mounting; see pages 61-62 for part numbers; 15.3 kW units only	
134	295027	CYLINDER, hydraulic; see page 65	1	171		WIRE, jumper; see page 59 for part numbers; 8.0 kW units only	
135		SCREW, cap, socket hd; 5/16-18 x 1-1/2 in. (38 mm)	6	172		ELBOW; 3/4-16 x 1/2 in. (13 mm) OD tube	4
136		ELBOW; 3/8 npt(m) x 1/2 in. (13 mm) OD tube	1	173		ELBOW, street; 1/4 npt (mx f)	1
137	295571	SWITCH, reversing	1	174		SCREW, cap, socket hd; 3/8-16 x 2 in. (51 mm)	1
138		WASHER, lock, internal tooth; no. 8	2	175*		SCREW, set, socket hd; 1/2-20 x 1/2 in. (13 mm)	1
140	295850	CLEVIS, hydraulic cylinder	2	178		RIVET; 5/32 in. (4 mm) diameter x 1/2 in. (13 mm)	4
141	295829	PLUG; 3/8 npt	1	180		SCREW, hex hd flanged; 3/8-16 x 5/8 in. (16 mm)	6
142	295828	BUSHING; bronze	1	181	15H524	ACCUMULATOR, pressure; 1/4 npt (m x f)	1
143		ELBOW; 1/4 npt(m) x 3/8 in (10 mm) OD tube	1	182		SCREW, cap, flange hd; 5/16-18 x 1 in. (25 mm)	2
144	106258	O-RING; fluoroelastomer	2	183		BUSHING, pipe; 1/2 npt(m) x 1/4 npt(f)	1
145	177156	O-RING; fluoroelastomer	1	184		NUT, hex, flange hd; 5/16-18	2
147	296223	FITTING, straight; 3/4 ORB x 7/8 JIC	1	185	15H704	SHIELD, fan	1
148	298107	CYLINDER, ISO lube	1	189	120448	SUPPRESSOR, ferrite; 250 ohm	1
149	295851	PIN, clevis	2	190	119253	SUPPRESSOR, ferrite; 151 ohm	1
150		FITTING, straight; 3/8 npt x 1/2 in. (13 mm) OD tube	1	191	112793	O-RING, Buna-N	2
151	253185	BRACKET, motor mount	1				
152	253187	COVER, access	1				
156▲	15B679	LABEL, warning	1				

▲ Replacement Danger and Warning labels, tags, and cards are available at no cost.

* These parts are included in Hydraulic Pump Replacement Kit 253573.

Parts that Vary by Model

Use the tables on pages 59-62 to find parts that vary by model. Find the ref. no. of part in left column, and Reactor model across top of the table. Intersection is correct part no.

See pages 53-59 for parts used on all models.

Model H-25, 8.0 kW Reactor

Ref. No.	Description	Model H-25, 8.0 kW Reactor						Qty
		253200 (230V, 1 phase)	253201 (230V, 3 phase)	253202 (380V, 3 phase)	253300 (230V, 1 phase)	253301 (230V, 3 phase)	253302 (380V, 3 phase)	
2	HEATER; page 35	253189	253189	253189	253189	253189	253189	1
8	TRANSFORMER	15B351	15B351	15B351	15B352	15B352	15B352	1
14	TUBE, inlet, component A	15H165	15H165	15H165	15H165	15H165	15H165	1
15	TUBE, outlet, component A	15H164	15H164	15H164	15H164	15H164	15H164	1
16	TUBE, inlet, component B	15H162	15H162	15H162	15H162	15H162	15H162	1
17	TUBE, outlet, component B	15H163	15H163	15H163	15H163	15H163	15H163	1
26	MODULE, breaker; pages 69-70	246090	246087	246096	246090	246087	246096	1
37	INSULATOR, heater	167002	167002	167002	167002	167002	167002	2
52	COVER, heater	253194	253194	253194	253194	253194	253194	2
132	PUMP, proportioning; see 311391	247377	247377	247377	247377	247377	247377	2
163	SCREW, cap, hex hd; 5/16-18 x 5/8 in. (16 mm)							14
165	SWITCH, added pole; 380V			117553			117553	1
171	WIRE, jumper, with quick disconnect	15H187	15H187	15H187	15H187	15H187	15H187	1
193	KIT, retrofit, in-rush limiter, 380V			288346			288346	1
193a	FUSE, 1.6 amp, slo-blow, included in kit 288346			120614			120614	1

Model H-25, 15.3 kW Reactor

Ref. No.	Description	Model H-25, 15.3 kW Reactor						Qty
		253206 (230V, 1 phase)	253207 (230V, 3 phase)	253208 (380V, 3 phase)	253306 (230V, 1 phase)	253307 (230V, 3 phase)	253308 (380V, 3 phase)	
2	HEATER; page 35	253911	253911	253911	253911	253911	253911	2
8	TRANSFORMER	15B351	15B351	15B351	15B352	15B352	15B352	1
14	TUBE, inlet, component A	15H169	15H169	15H169	15H169	15H169	15H169	1
15	TUBE, outlet, component A	15H168	15H168	15H168	15H168	15H168	15H168	1
16	TUBE, inlet, component B	15H166	15H166	15H166	15H166	15H166	15H166	1
17	TUBE, outlet, component B	15H167	15H167	15H167	15H167	15H167	15H167	1
26	MODULE, breaker; pages 69-70	246092	246089	246098	246092	246089	246098	1
37	INSULATOR, heat	167002	167002	167002	167002	167002	167002	4
52	COVER, heater	253196	253196	253196	253196	253196	253196	2
132	PUMP, proportioning; see 311391	247377	247377	247377	247377	247377	247377	2
163	SCREW, cap, hex hd; 5/16-18 x 5/8 in. (16 mm)							22
165	SWITCH, added pole; 380V			117553			117553	1
170	BRACKET, heater mounting	253192	253192	253192	253192	253192	253192	2
193	KIT, retrofit, in-rush limiter, 380V			288346			288346	1
193a	FUSE, 1.6 amp, slo-blow, included in kit 288346			120614			120614	1

Model H-XP2, 15.3 kW Reactor

Ref. No.	Description	Model H-XP2, 15.3 kW Reactor						Qty
		253203 (230V, 1 phase)	253204 (230V, 3 phase)	253205 (380V, 3 phase)	253303 (230V, 1 phase)	253304 (230V, 3 phase)	253305 (380V, 3 phase)	
2	HEATER; page 35	253911	253911	253911	253911	253911	253911	2
8	TRANSFORMER	15B351	15B351	15B351	15B352	15B352	15B352	1
14	TUBE, inlet, component A	15H169	15H169	15H169	15H169	15H169	15H169	1
15	TUBE, outlet, component A	15H168	15H168	15H168	15H168	15H168	15H168	1
16	TUBE, inlet, component B	15H166	15H166	15H166	15H166	15H166	15H166	1
17	TUBE, outlet, component B	15H167	15H167	15H167	15H167	15H167	15H167	1
26	MODULE, breaker; pages 69-70	246092	246089	246098	246092	246089	246098	1
37	INSULATOR, heat	167002	167002	167002	167002	167002	167002	4
52	COVER, heater	253196	253196	253196	253196	253196	253196	2
132	PUMP, proportioning; see 311391	247375	247375	247375	247375	247375	247375	1
163	SCREW, cap, hex hd; 5/16-18 x 5/8 in. (16 mm)							22
165	SWITCH, added pole; 380V			117553			117553	1
170	BRACKET, heater mounting	253192	253192	253192	253192	253192	253192	2
193	KIT, retrofit, in-rush limiter, 380V			288346			288346	1
193a	FUSE, 1.6 amp, slo-blow, included in kit 288346			120614			120614	1

253189 8.0 kW Dual Zone Heater

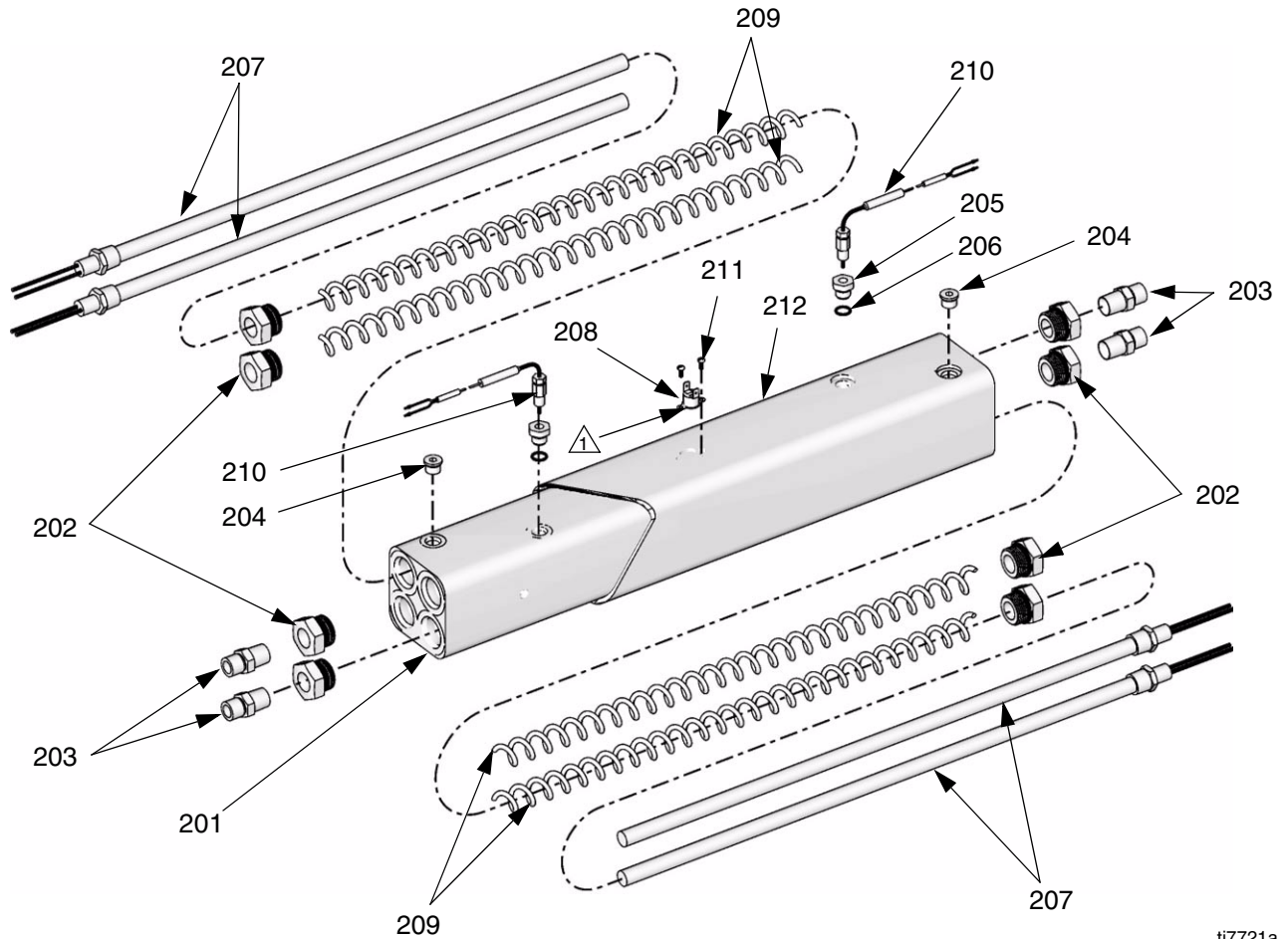



ti7721a

 Apply 110009 thermal heatsink compound.

Ref. No.	Part No.	Description	Qty
201	15H242	HOUSING, heater	1
202	15H302	FITTING, reducer	8
203	15H303	FITTING, adapter; 1/2 npt(m) x 1/2 in. (13 mm) OD tube	4
204	15H304	PLUG	2
205	15H306	ADAPTER, thermocouple	2
206	120336	O-RING; fluoroelastomer	2
207	15B139	HEATER, immersion; 2000 W	4
208	15B137	SWITCH, overtemperature	1
209	15B135	MIXER, immersion heater	4
210	117484	THERMOCOUPLE	2
211	100518	SCREW, machine, pan hd	2
212	15H205	INSULATOR	1

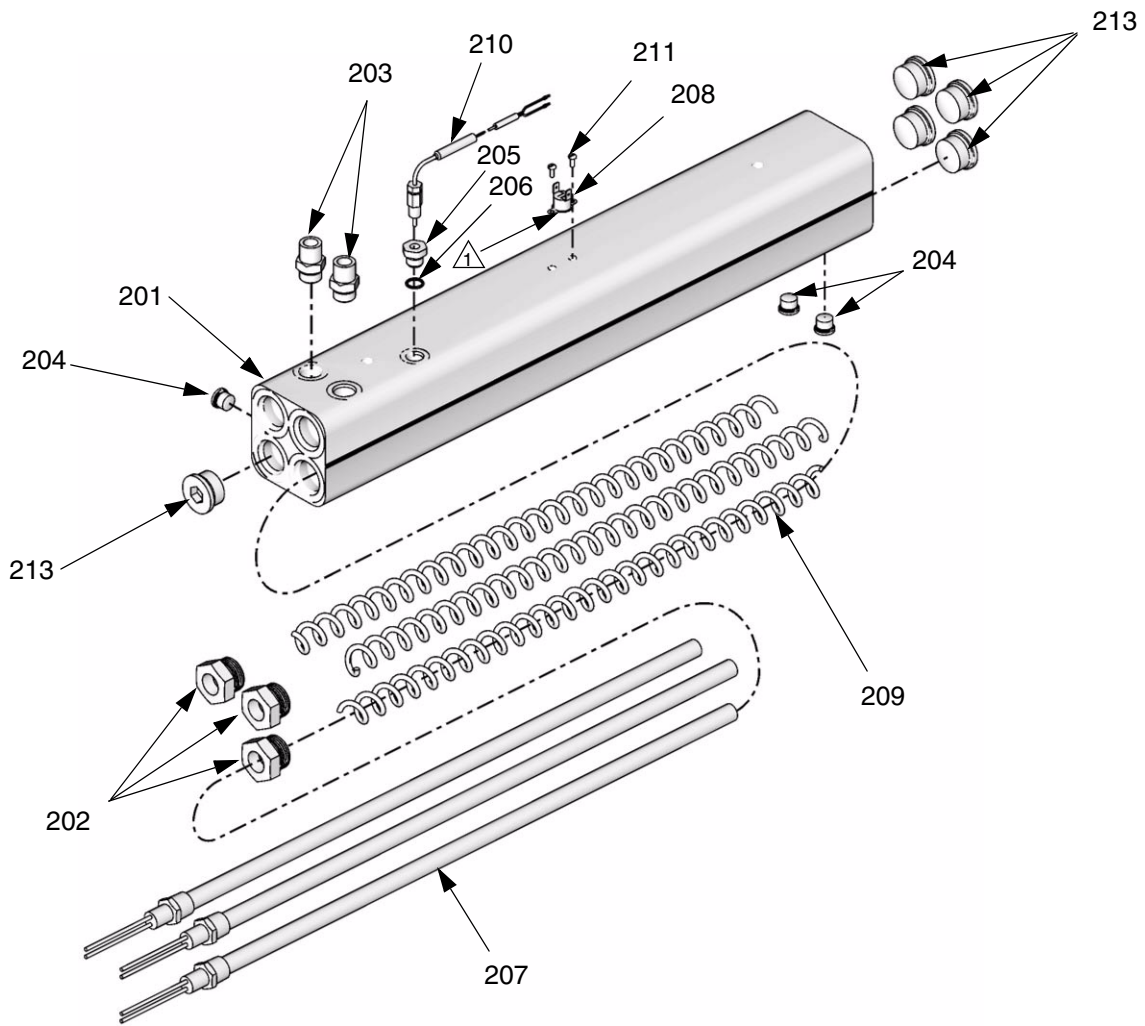
253911 7.65 kW Single Zone Heater (2 per machine)



 Apply 110009 thermal heatsink compound.

ti7723a

Ref. No.	Part No.	Description	Qty	Ref. No.	Part No.	Description	Qty
201	15J090	HOUSING, heater	1	208	15B137	SWITCH, overtemperature	1
202	15H302	FITTING, reducer	3	209	15B135	MIXER, immersion heater	3
203	15H307	FITTING, adapter; 3/4 SAE x 1/2 in. (13 mm) OD tube	2	210	117484	THERMOCOUPLE	1
204	15H308	PLUG	3	211	100518	SCREW, machine, pan hd	2
205	15H306	ADAPTER, thermocouple	1	213	15H305	FITTING, plug, hollow	5
206	120336	O-RING; fluoroelastomer	1				
207	15B138	HEATER, immersion; 2550 W	3				

295027 Hydraulic Cylinder

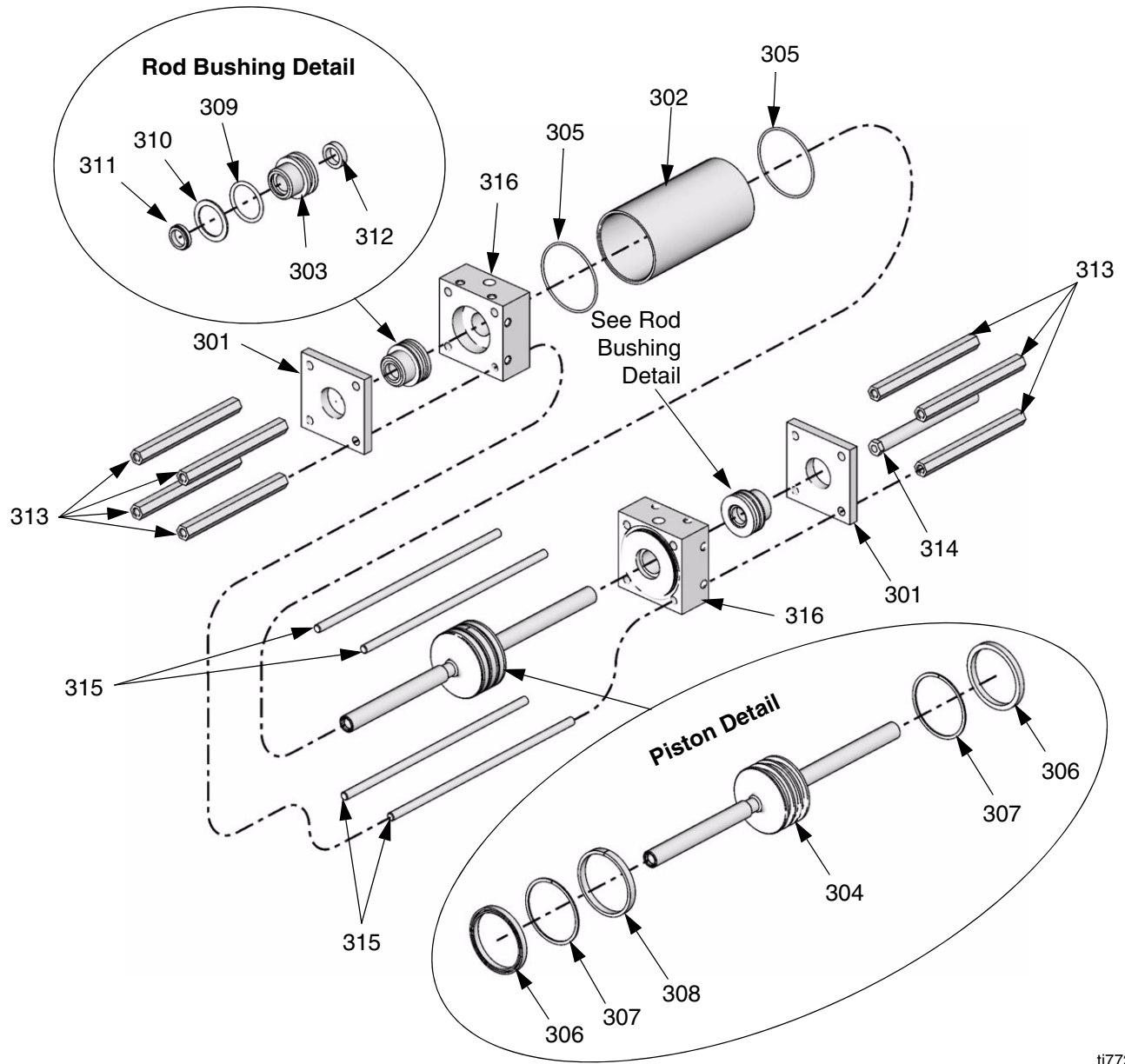

ti7727a

Ref. No.	Part No.	Description	Qty	Ref. No.	Part No.	Description	Qty
301	295029	PLATE, retainer	2	309	158776	O-RING	2
302	295030	CYLINDER	1	310	295644	RING, backup	2
303	295031	BUSHING, rod	2	311	295645	WIPER, rod	2
304	295028	PISTON	1	312	295646	SEAL, shaft	2
305	295640	O-RING	2	313	295032	SPACER, proportioning pump	7
306	295641	U-CUP	2	314	295033	SPACER, reverse switch	1
307	295642	RING, backup	2	315	295034	ROD, tie	4
308	295643	RING, wear	1	316	295035	BLOCK, port	2

245974 Display

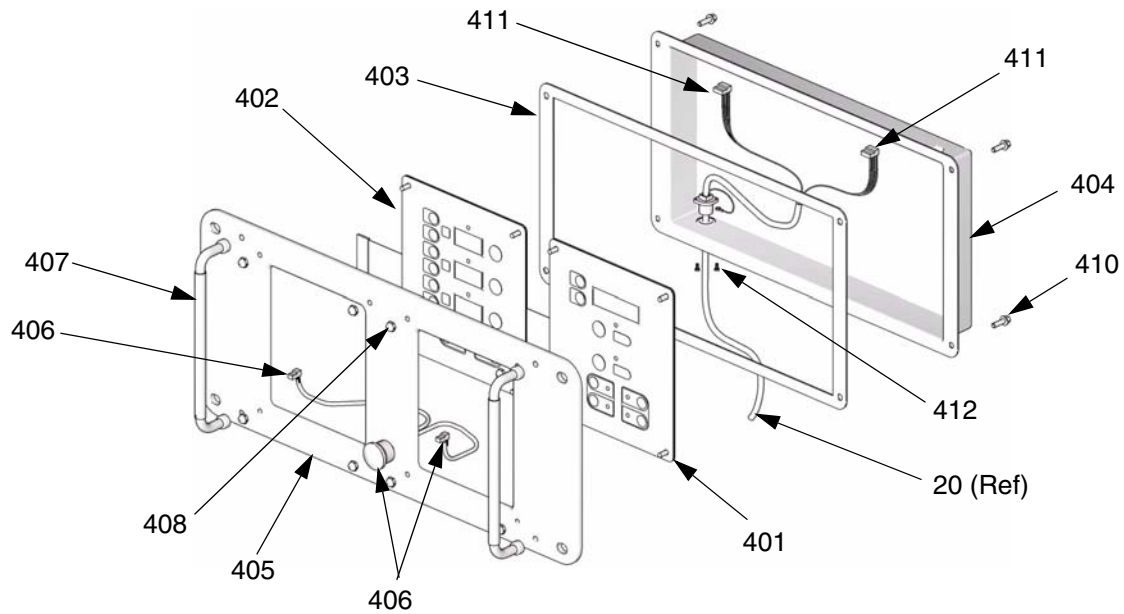

ti2574a

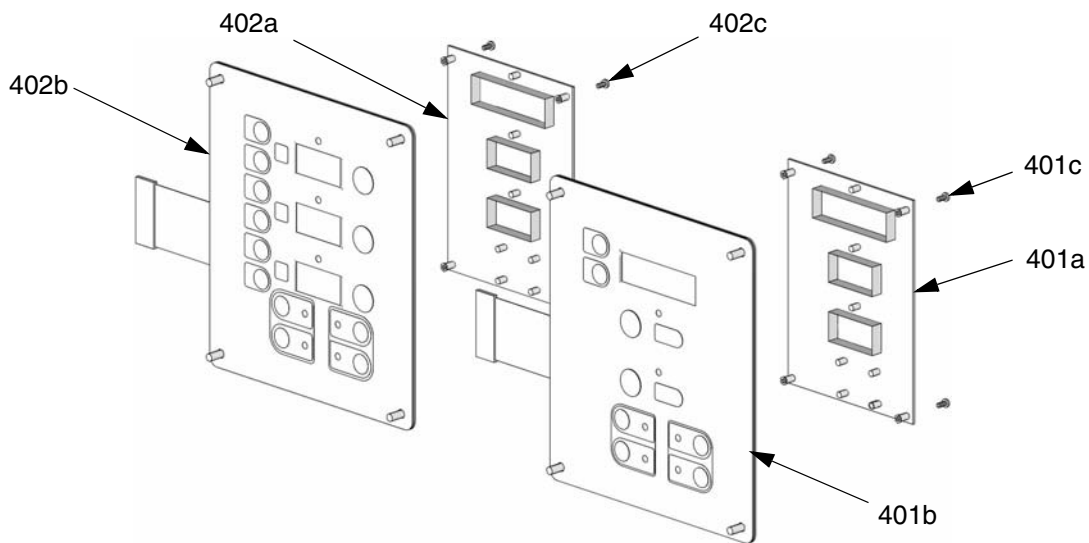

ti3172a

Ref. No.	Part No.	Description	Qty	Ref. No.	Part No.	Description	Qty
401	245978	DISPLAY, pressure; includes 401a-401c	1	403	15B293	GASKET	1
401a	246130	.BOARD, circuit	1	404	15B292	COVER	1
401b	246478	.SWITCH, membrane	1	405	15B291	PLATE	1
401c	112324	.SCREW	4	406	246287	HARNESS, wire, red stop button	1
402	245977	DISPLAY, temperature; includes 402a-402c	1	407	117499	HANDLE	2
402a	246130	.BOARD, circuit	1	408	117523	NUT, cap; 10-24	8
402b	246479	.SWITCH, membrane	1	410	111393	SCREW, machine, pan-hd; M5 x 0.8; 16 mm	4
402c	112324	.SCREW	4	411	15B386	CABLE, display	1
				412	195853	SCREW, machine; M2.5 x 6	2

245979 Temperature Control

 Apply 110009 thermal heatsink compound to mating surfaces.

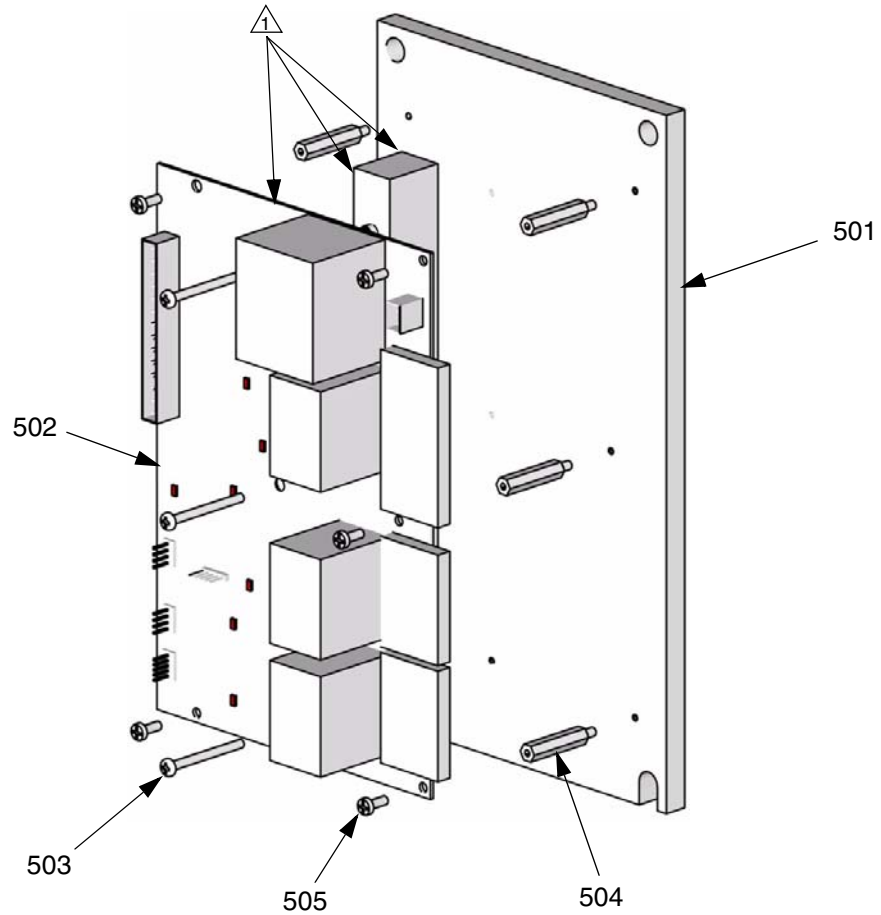

ti2575a

Ref. No.	Part No.	Description	Qty
501	15B779	HEAT SINK	1
502	246194	BOARD, temperature control	1
503	117683	SCREW, 6-32 x 1-1/2 in. (38 mm)	2
504	117526	SPACER	5
505	104590	SCREW, machine; 6-32 x 3/8 in. (10 mm)	5

246154 Fluid Manifold

- ① Apply 113500 thread lock (blue).
- ② Torque to 355-395 in-lb (40.1-44.6 N•m).
- ③ Apply PTFE tape or thread sealant to tapered threads.
- ④ Torque to 175-195 in-lb (19.8-22.0 N•m).
- ⑤ Lubricate ends of spring when assembling.
- ⑥ Assemble valves (702) and handles (709) with handles facing away from each other.
- ⑦ Assemble seat (707) with lapped seat facing valve (702).
- ⑧ Apply grease (118665) to seat (707) and seal (708) prior to inserting into valve (702) to aid retention during assembly to manifold (701).

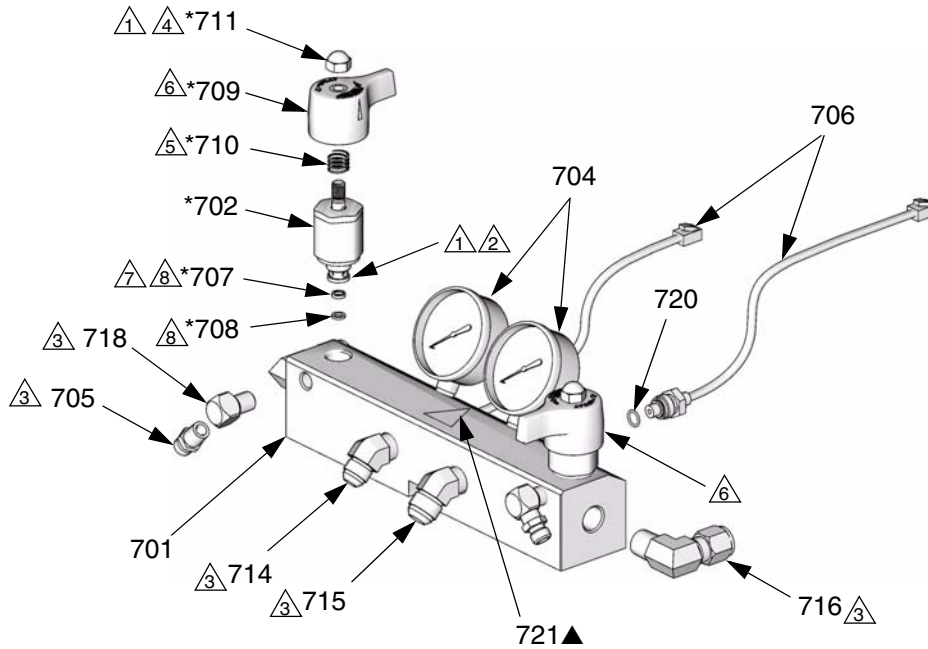

ti2573a

Ref. No.	Part No.	Description	Qty	Ref. No.	Part No.	Description	Qty
701	15B332	MANIFOLD; aluminum	1	715	117557	ELBOW, 45°; #10 JIC x 1/2 npt	1
702*	246161	VALVE, pressure relief/spray	2	716	117532	ELBOW; 1/2 npt(m) x 1/2 in. (13 mm) OD tube	2
704	102814	GAUGE; 5000 psi (35 MPa, 350 bar)	2	718	100840	ELBOW, street; 1/4 npsm x 1/4 npt	2
705	162453	NIPPLE; 1/4 npt x 1/4 npsm	2	720	111457	O-RING; PTFE	2
706	246123	TRANSDUCER, pressure control	2	721▲	189285	LABEL, caution	1
707*	193709	SEAT, valve; carbide	2	* Included in Repair Kit 246842 (purchase separately).			
708*	193710	SEAL, seat; nylon	2	▲ Replacement Warning labels, signs, tags, and cards are available at no cost.			
709*	15B287	HANDLE, valve	2				
710*	114708	SPRING	2				
711*	117623	NUT, cap; 3/8-16	2				
714	117556	ELBOW, 45°; #8 JIC x 1/2 npt	1				

Circuit Breaker Modules

230V, 3 Phase Circuit Breaker Modules

Part No. 246087 (H-25)
Part No. 246089 (H-XP2)

 For wiring and cable connections, refer to electrical diagrams manual 311508, supplied. See page 71 for parts list.

* Ref. No. 92 is not included with module.
Order separately, see page 58.

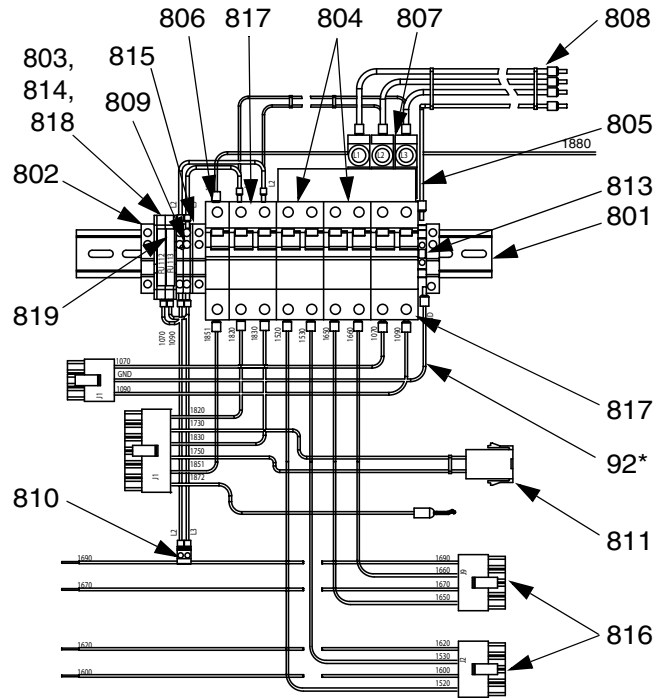

230V, 1 Phase Circuit Breaker Modules

Part No. 246090 (H-25)
Part No. 246092 (H-XP2)

 For wiring and cable connections, refer to electrical diagrams manual 311508, supplied. See page 71 for parts list.

* Ref. No. 92 is not included with module.
Order separately, see page 58.

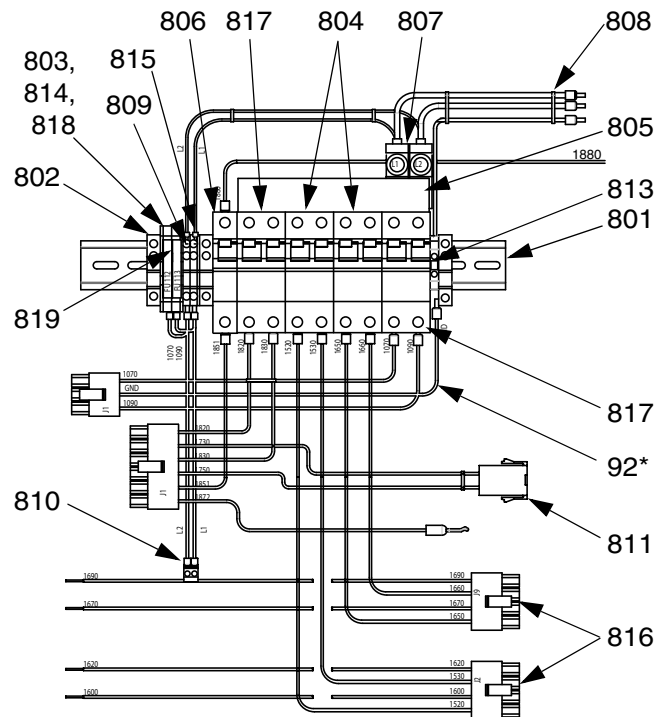

380V, 3 Phase Circuit Breaker Modules

Part No. 246096 (H-25)

Part No. 246098 (H-XP2)

 For wiring and cable connections, refer to electrical diagrams manual 311508, supplied. See page 71 for parts list.

* Ref. No. 92 is not included with module.
Order separately, see page 58.

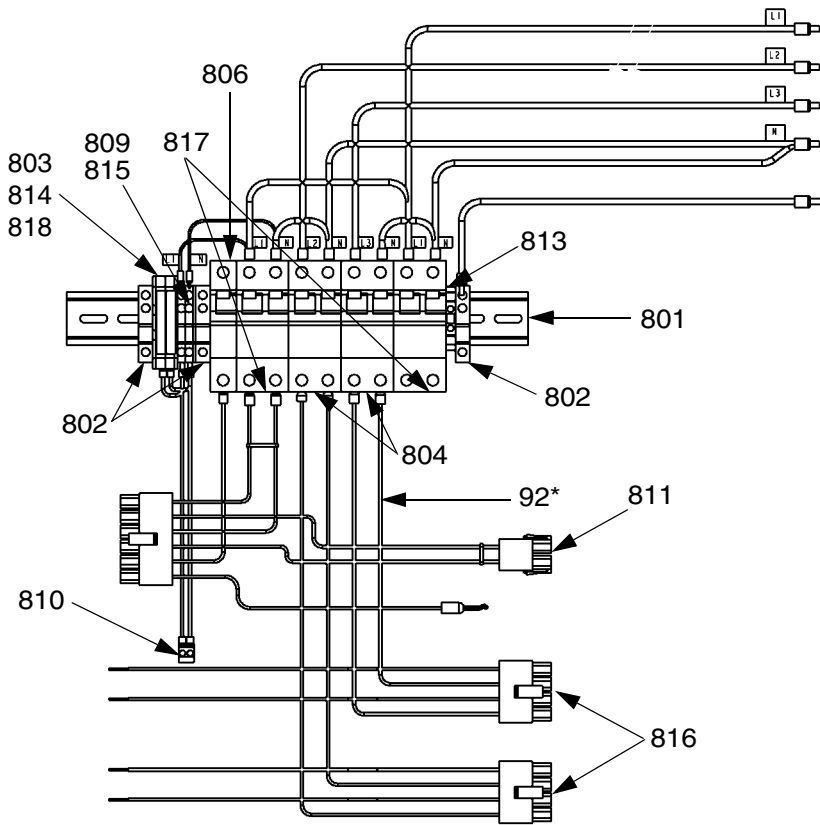

Circuit Breaker Modules Parts List

Ref. No.	Description	Breaker Modules						Qty
		246087 230V, 3 phase	246089 230V, 3 phase	246090 230V, 1 phase	246092 230V, 1 phase	246096 380V, 3 phase	246098 380V, 3 phase	
801	RAIL, mounting	buy locally	buy locally	buy locally	buy locally	buy locally	buy locally	1
802	CLAMP, end	112446	112446	112446	112446	112446	112446	3
803	TERMINAL, base, fuse plug	117798	117798	117798	117798	117798	117798	2
804	BREAKER, dual; 25A	117591		117591		117591		2
	BREAKER, dual; 40A		117505		117505		117505	2
805	BAR, power buss, 3 phase	117805	117805					1
	BAR, power buss, 1 phase			117678	117678			1
806	BREAKER, single; 50A	117503	117503	117503	117503	117503	117503	1
807	CONNECTOR, power lug	117679	117679					3
	CONNECTOR, power lug			117679	117679			2
808	CABLE, harness; 230V, 3 phase	15B387	15B387					1
	CABLE, harness; 230V, 1 phase			117674	117674			1
	CABLE, harness; 380V, 3 phase					15B377	15B377	1
809	TERMINAL, block	117796	117796	117796	117796	117796	117796	2
810	CABLE, harness, power temp	15B375	15B375	15B375	15B375	15B375	15B375	1
811	CABLE, hose, heat	15B378	15B378	15B378	15B378	15B378	15B378	1
813	BLOCK, terminal ground	112443	112443	112443	112443	112443	112443	1
814	FUSE, fan; 5 x 20 mm Bussman GDA-2A or equivalent	115216	115216	115216	115216	115216	115216	2
815	TERMINAL, end cover	117807	117807	117807	117807	117807	117807	1
816	CABLE, harness, heat A/B	15B376	15B376	15B376	15B376	15B376	15B376	2
817	BREAKER, dual; 20A	117711	117711	117711	117711	117711	117711	2
818	TERMINAL, end cover	117797	117797	117797	117797	117797	117797	1
819	FUSE, plug	117799	117799	117799	117799	117799	117799	2

Technical Data

Category	Data
Maximum Fluid Working Pressure	Model H-25: 2000 psi (13.8 MPa, 138 bar) Model H-XP2: 3500 psi (24.1 MPa, 241 bar)
Fluid:Oil Pressure Ratio	Model H-25: 1.91:1 Model H-XP2: 2.79:1
Fluid Inlets	Component A (ISO): 3/4 npt(f), 250 psi (1.75 MPa, 17.5 bar) maximum Component B (RES): 1/2 npt(f), 250 psi (1.75 MPa, 17.5 bar) maximum
Fluid Outlets	Component A (ISO): #8 JIC with #5 JIC adapter Component B (RES): #10 JIC with #6 JIC adapter
Fluid Circulation Ports	1/4 npsm(m), with plastic tubing, 250 psi (1.75 MPa, 17.5 bar) maximum
Ambient Temperature Range	0 to 140°F (-18 to 60°C)
Maximum Fluid Temperature	190°F (88°C)
Maximum Output (10 weight oil at ambient temperature)	Model H-25: 22 lb/min (10 kg/min) at 35 cycles/min (60 Hz) Model H-XP2: 1.5 gpm (5.7 liter/min) at 35 cycles/min (60 Hz)
Output per Cycle (A and B)	Model H-25: 0.063 gal. (0.23 liter) Model H-XP2: 0.042 gal. (0.16 liter)
Line Voltage Requirement	230V 1 phase and 230V 3 phase units: 195-264 Vac, 50/60 Hz 380V 3 phase units: 338-457 Vac, 50/60 Hz
Amperage Requirement	See tables, page 3.
Heater Power (A and B heaters total, no hose)	See tables, page 3.
Hydraulic reservoir capacity	1.2 gal. (4.5 liters)
Recommended hydraulic fluid	See TABLE 11, page 49.
Sound power, per ISO 9614-2	Model H-25: 87.8 dB(A) at 1200 psi and 20 lb/min (8.4 MPa, 84 bar and 9 kg/min) Model H-XP2: 87.8 dB(A) at 2000 psi and 1.36 gpm (13.8 MPa, 138 bar and 5.2 liter/min)
Sound pressure, 1 m from equipment	Model H-25: 80.2 dB(A) at 1200 psi and 20 lb/min (8.4 MPa, 84 bar and 9 kg/min) Model H-XP2: 80.2 dB(A) at 2000 psi and 1.36 gpm (13.8 MPa, 138 bar and 5.2 liter/min)
Weight	Units with 8 kW Heaters: 498 lb (226 kg) Units with 15.3 kW Heaters: 525 lb (238 kg)
Wetted Parts	Aluminum, stainless steel, zinc-plated carbon steel, brass, carbide, chrome, fluoroelastomer, PTFE, ultra-high molecular weight polyethylene, chemically resistant o-rings

All other brand names or marks are used for identification purposes and are trademarks of their respective owners.



Multiple horizontal lines for writing or drawing.

Graco Standard Warranty

Graco warrants all equipment referenced in this document which is manufactured by Graco and bearing its name to be free from defects in material and workmanship on the date of sale to the original purchaser for use. With the exception of any special, extended, or limited warranty published by Graco, Graco will, for a period of twelve months from the date of sale, repair or replace any part of the equipment determined by Graco to be defective. This warranty applies only when the equipment is installed, operated and maintained in accordance with Graco's written recommendations.

This warranty does not cover, and Graco shall not be liable for general wear and tear, or any malfunction, damage or wear caused by faulty installation, misapplication, abrasion, corrosion, inadequate or improper maintenance, negligence, accident, tampering, or substitution of non-Graco component parts. Nor shall Graco be liable for malfunction, damage or wear caused by the incompatibility of Graco equipment with structures, accessories, equipment or materials not supplied by Graco, or the improper design, manufacture, installation, operation or maintenance of structures, accessories, equipment or materials not supplied by Graco.

This warranty is conditioned upon the prepaid return of the equipment claimed to be defective to an authorized Graco distributor for verification of the claimed defect. If the claimed defect is verified, Graco will repair or replace free of charge any defective parts. The equipment will be returned to the original purchaser transportation prepaid. If inspection of the equipment does not disclose any defect in material or workmanship, repairs will be made at a reasonable charge, which charges may include the costs of parts, labor, and transportation.

THIS WARRANTY IS EXCLUSIVE, AND IS IN LIEU OF ANY OTHER WARRANTIES, EXPRESS OR IMPLIED, INCLUDING BUT NOT LIMITED TO WARRANTY OF MERCHANTABILITY OR WARRANTY OF FITNESS FOR A PARTICULAR PURPOSE.

Graco's sole obligation and buyer's sole remedy for any breach of warranty shall be as set forth above. The buyer agrees that no other remedy (including, but not limited to, incidental or consequential damages for lost profits, lost sales, injury to person or property, or any other incidental or consequential loss) shall be available. Any action for breach of warranty must be brought within two (2) years of the date of sale.

GRACO MAKES NO WARRANTY, AND DISCLAIMS ALL IMPLIED WARRANTIES OF MERCHANTABILITY AND FITNESS FOR A PARTICULAR PURPOSE, IN CONNECTION WITH ACCESSORIES, EQUIPMENT, MATERIALS OR COMPONENTS SOLD BUT NOT MANUFACTURED BY GRACO. These items sold, but not manufactured by Graco (such as electric motors, switches, hose, etc.), are subject to the warranty, if any, of their manufacturer. Graco will provide purchaser with reasonable assistance in making any claim for breach of these warranties.

In no event will Graco be liable for indirect, incidental, special or consequential damages resulting from Graco supplying equipment hereunder, or the furnishing, performance, or use of any products or other goods sold hereto, whether due to a breach of contract, breach of warranty, the negligence of Graco, or otherwise.

FOR GRACO CANADA CUSTOMERS

The Parties acknowledge that they have required that the present document, as well as all documents, notices and legal proceedings entered into, given or instituted pursuant hereto or relating directly or indirectly hereto, be drawn up in English. Les parties reconnaissent avoir convenu que la rédaction du présente document sera en Anglais, ainsi que tous documents, avis et procédures judiciaires exécutés, donnés ou intentés, à la suite de ou en rapport, directement ou indirectement, avec les procédures concernées.

Graco Information

TO PLACE AN ORDER, contact your Graco distributor or call to identify the nearest distributor.

Phone: 612-623-6921 **or Toll Free:** 1-800-328-0211 **Fax:** 612-378-3505

*All written and visual data contained in this document reflects the latest product information available at the time of publication.
Graco reserves the right to make changes at any time without notice.*

This manual contains English. MM 311300

Graco Headquarters: Minneapolis
International Offices: Belgium, China, Japan, Korea

GRACO INC. P.O. BOX 1441 MINNEAPOLIS, MN 55440-1441

Copyright 2006, Graco Inc. is registered to ISO 9001

www.graco.com
Revised 1/2009