

muratec

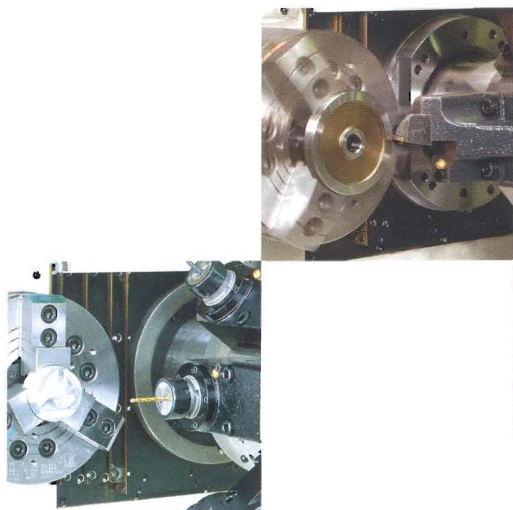

**Twin Spindle / Single Spindle CNC Chucker
CNC Turning Center**

MW&MS Series
MD Series
MJ Series

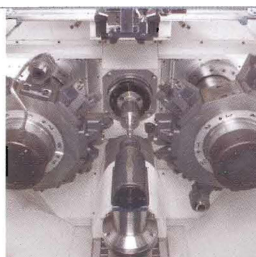
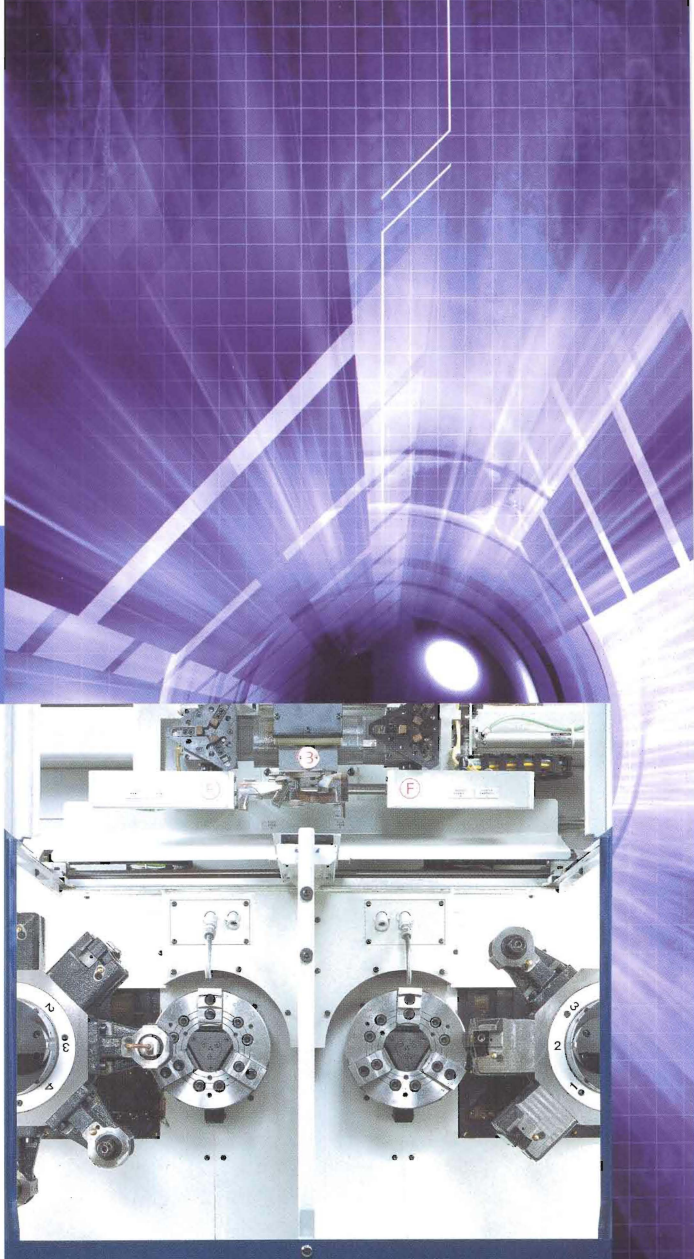

MURATA MACHINERY, LTD.

Muratec's CNC Chuckers / Turning Centers - Your

Twin Spindle CNC Chucker

MW SERIES



Single Spindle CNC Chucker

MS SERIES



Muratec's CNC Chuckers / Turning Centers are designed to exceed

Muratec's unprecedented machine features include precision machining, line planning, higher productivity, automation reliability, longer unattended production, machine rigidity, energy saving and turnkey experience for automobile component manufacturing. These outstanding features have made our machines extremely successful in the worldwide market. Our wealth of turnkey experience includes automotive parts manufacturing for; Electrical power steering, Continuous variable transmission (CVT), high precision light weight hubs, energy saving high performance engines, automotive compressors and more. Muratec continually strives to provide the latest technology in machines, and extremely reliable application solutions to boost productivity and profitability for our customers.

Transmission Parts

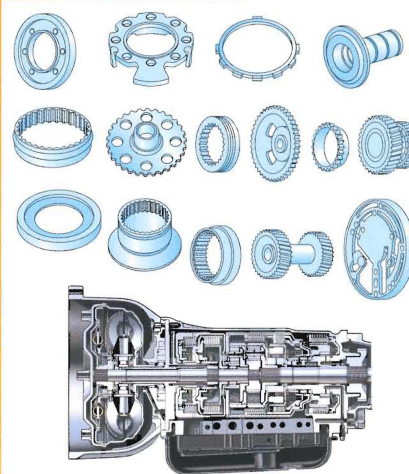

Engine Parts

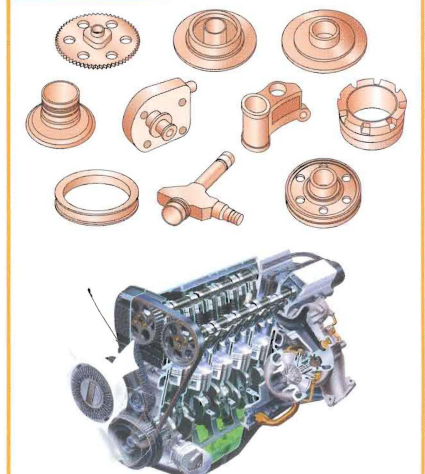

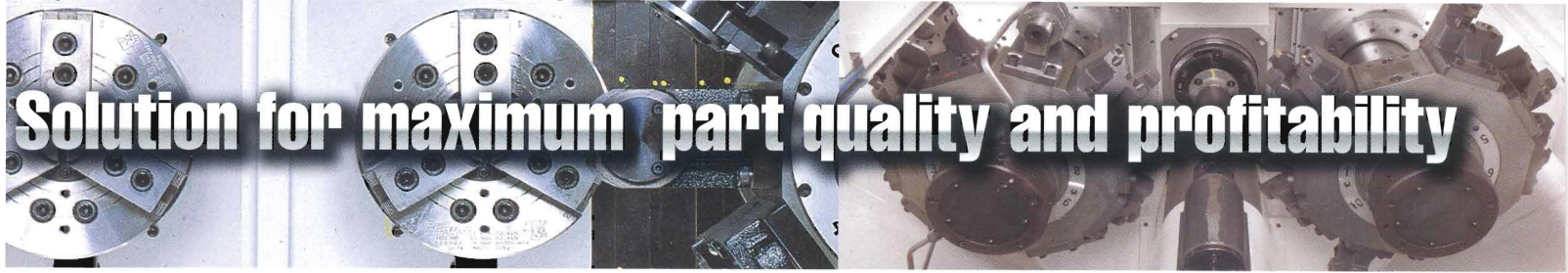

Solution for maximum part quality and profitability

CNC Turning Center

MD SERIES

CNC Turning Machine with tailstock

MJ SERIES



the challenging requirements of turning automotive components

Steering Parts

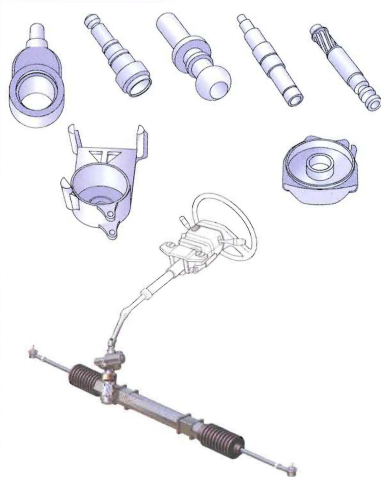

Compressor Parts

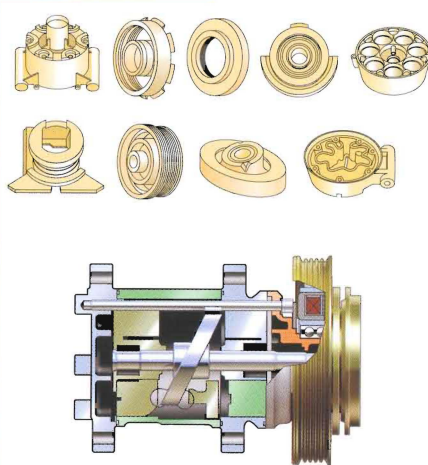

Power Train Parts

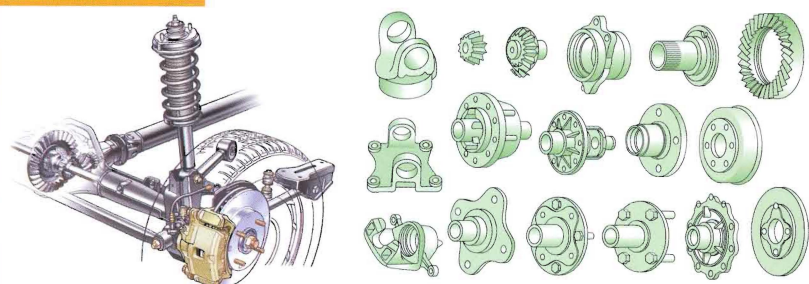

High Accuracy and High Rigidity -Heavy Duty Machining with Column and Turret Bar Design

■ Completely Separate Beds

The twin spindle turning machines are built with completely separate bed constructions. Separate beds eliminate the transfer of harmonic vibrations. This unique design provides excellent workpiece roundness and tremendous surface finish capabilities.

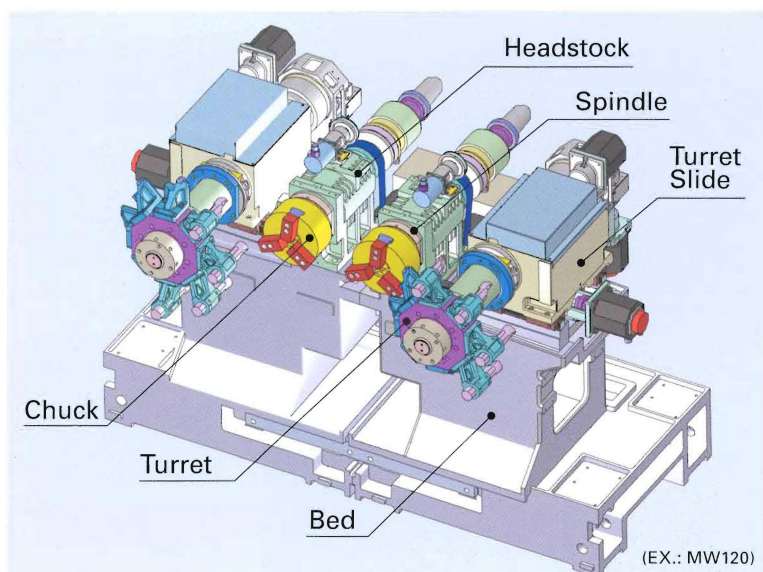

The turret and spindle are designed parallel to each other. Decades of column/turret style MW machines in the field have proven the superior design of these machines. This design supports heavy cuts, accurate finishing and allows free chip fall.

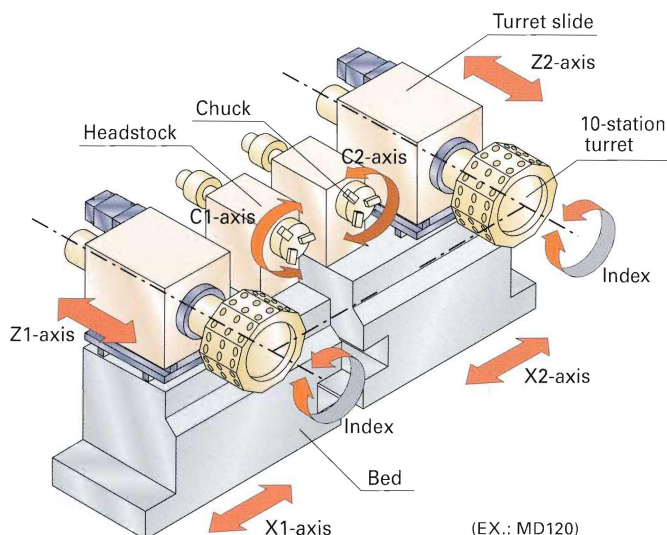

■ Exceptional Column Structure

The turret and spindles are arranged parallel. This field proven turret design, supports heavy cuts, accurate finishing and allows free chip fall.

■ Turret Design

Column type turret design provides exceptional rigidity, smooth axis movement, high speed positioning and when combined, results in stable cutting, close tolerances, and high productivity.

Better Machine Utilization, Easy Set-Up, Simple Operation and Quick

■ Easy Operator Set-Up

The wide-open front of the machine permits the operator convenient access to the spindle, turnaround chucks, and gantry grippers. Tool access is ergonomically designed.

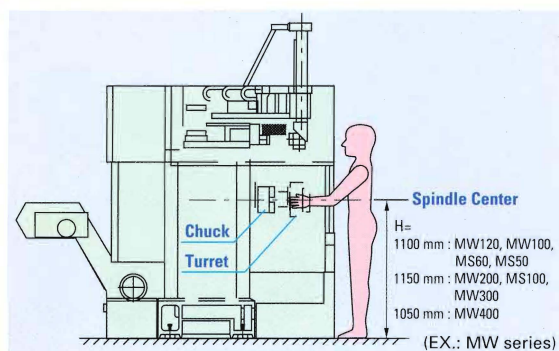

■ Careful Attention to Operating Environment and Safety

Front and top guards are incorporated into enclosure. In the simple motion of opening the doors, the entire work area is available to the operator.

The glass is 16 mm laminated shatterproof polycarbonate with excellent clarity and durability.



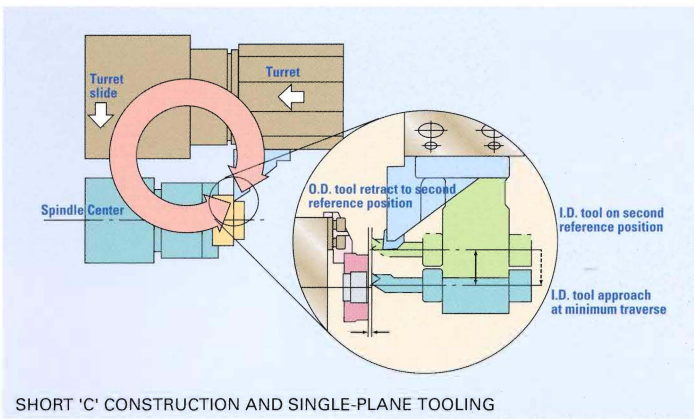

■ Short 'C' Construction

Closed 'C' loop between chuck and cutting tool enhances machining rigidity, allowing for full utilization of spindle and live tool power over a wide speed range.

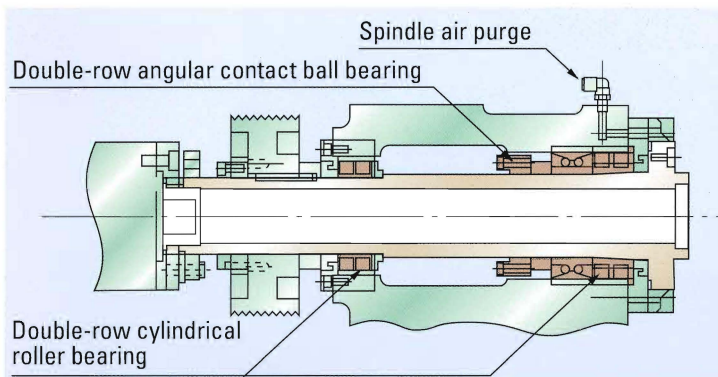

■ Stable, High Speed Spindle

Symmetrical headstocks with low temperature grease lube bearings provide high speed and rigid cutting conditions with consistent workpiece tolerance. Standard positive air pressure supply behind the front spindle seal prevents invasion of coolant and small particles to preserve bearing life.

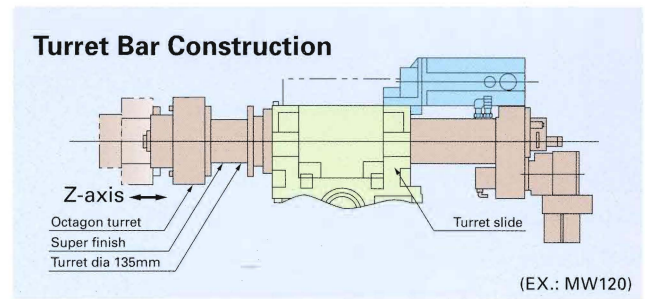

■ Turret Design (Except MW100, MW50, MS50)

The unique round turret design is supported on hydrostatic bearings over a wide span. Our hydraulic curvic coupling design provides exceptional rigidity, smooth axis movement and high speed positioning. When combined, these advanced designs results in stable cutting, close tolerances, and high productivity.

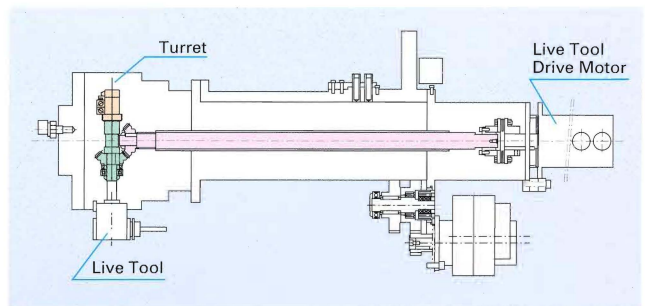

■ Live Tool Drive

The MD Series turning centers incorporate live tool drive on the turret as a standard feature with spindle drive positioning control. The live tool position is available on all the turret stations. The live tool heads are available as an option. Rigid tapping is available as a standard function.

Maintenance

■ Improved Chip Disposal

The coolant sump is on casters and separate from the chip conveyor. The coolant tank simply rolls out from under the front of the machine.

The conveyor stays fixed in the machine. The chip pan has steep sidewalls to guide chips into the conveyor.

Portable chip boxes sit in the coolant sump along the bottom of the chip conveyor to catch stray chips that remained on the return. Chip disposal may be selected right, left or rear of machine.



■ Complete Maintenance Access Through Rear Wide Open Area

Electrically interlocked one-lift/ one-slide-off action rear guard permits immediate access to all important maintenance parts.



MW & MS SERIES

MW series chucker come with column / turret bar design for heavy duty cutting capabilities, precision machining and high rigidity.

MS series single spindle chucks are designed for high speed, compact, automated line planning requirements.

The New Super Compact Twin Spindle Chucker Machine Machine Width : 1,220mm

MW50

MW50
Single loader type
Twin Spindle CNC Chucker



Gang tooling construction eliminates turret indexing time for significant cycle time reduction.



Tools used: 4 numbers/ Spindle

Proven 3-axis Gantry loader design with worldwide 8,000 installations.



Loader capacity: ϕ 50 mm x L 50 mm, 0.5 kg x 2
Max. Feed rate: X-axis 180 m/min
Y-axis 130 m/min
Z-axis 55 m/min

Compact footprint, yet easy maintenance access.



Muratec Design Concept for Small Parts Production

High Power Cutting Capability!

5.5 kW Spindle power and ϕ 80mm (option: ϕ 90 mm) main spindle bearing allows for efficient machining of small parts.

Reduction in idle time!

Gang tooling construction allows for a reduction in machine idle time (No turret indexing).

Space Saving Design!

Space saving Twin-spindle machine design (Width 1220 mm, Depth 1985 mm, Floor Space 2.4 m²) allows compact floor layouts.

Basic Machine Specifications

		MW50 Single loader
Number of spindles		2
Distance between spindle centers		620 mm
Maximum chuck size	Standard	ϕ 165 mm (ϕ 6 inch)
	Option	—
Number of turret stations	Standard	Tool plate x 2 / Width : 270 mm
Spindle nose size		Flat nose
Diameter of spindle bore		ϕ 32 mm
Spindle diameter at front bearing mounting		ϕ 80 mm
Spindle speed range	Standard A	50 rpm ~ 5000 rpm
	Standard B	60 rpm ~ 6000 rpm
Spindle drive motor	Standard	5.5 kW/30min x 2
	Option	7.5 kW/30min x 2
Total weight		3,400 kg

**Better Cost Performance for Work Size
 ø 60 mm x 40 mm Length**

MW100 & MS50

(Chuck size 6")

A synchronous twin loader operation enables minimum cycle time of 14 seconds for 2 workpieces.



MW100
 Single loader type
 Twin Spindle CNC Chucker

MW100
 Twin loader type
 Twin Spindle CNC Chucker
 Designed for quick cycle time parts production.



MW100
 Spindle isolation type
 Twin Spindle CNC Chucker
 Left spindle/turret, Right spindle/turret, and Gantry loader are separated.

MS50
 Single loader type
 Single Spindle CNC Chucker
 6" chuck capacity, compact and an ideal design for line planning with a floor contact width of only 980 mm.

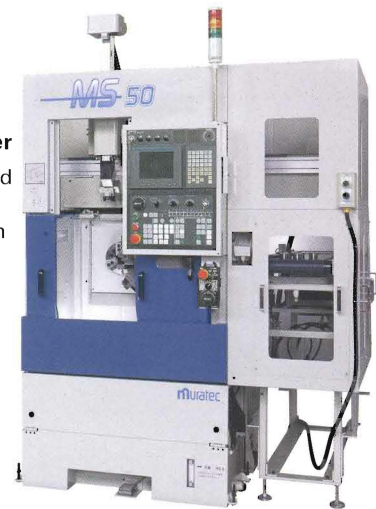

Basic Machine Specifications

	MW100 Single loader	MW100 Twin loader	MW100 Spindle isolation	MS50 Single loader
Number of spindles	2	2	2	1
Distance between spindle centers	340 mm	340 mm	340 mm	—
Maximum chuck size	ø 165 mm (ø 6 inch)	ø 165 mm (ø 6 inch)	ø 165 mm (ø 6 inch)	ø 165 mm (ø 6 inch)
Number of turret stations	8 × 2	8 × 2	8 × 2	8
Spindle nose size	JIS A2-5	JIS A2-5	JIS A2-5	JIS A2-5
Diameter of spindle bore	ø 47 mm	ø 47 mm	ø 47 mm	ø 47 mm
Spindle diameter at front bearing mounting	ø 80 mm	ø 80 mm	ø 80 mm	ø 80 mm
Spindle speed range	Standard A	45 rpm ~ 4500 rpm	45 rpm ~ 4500 rpm	45 rpm ~ 4500 rpm
	Standard B	30 rpm ~ 3000 rpm	30 rpm ~ 3000 rpm	30 rpm ~ 3000 rpm
	Standard C	60 rpm ~ 6000 rpm	60 rpm ~ 6000 rpm	60 rpm ~ 6000 rpm
Spindle drive motor	5.5 kW/continuous × 2	5.5 kW/continuous × 2	5.5 kW/continuous × 2	5.5 kW/continuous
Total weight	3,500 kg	3,600 kg	3,500 kg	2,200 kg

MW & MS SERIES

Best Seller Machine with Extreme Operational Flexibility

MW120 & MS60

(Chuck size 6", 8")



MW120
Single loader type
Twin Spindle CNC Chucker



A synchronous twin loader operation enables minimum cycle time of 15 seconds for 2 workpieces.

MW120
Twin loader type
Twin Spindle CNC Chucker
Designed for quick cycle time parts production.

MW120

Spindle isolation type Twin Spindle CNC Chucker

Left spindle/turret, Right spindle/turret, and Gantry loader are separated.



MS60

Single loader type Single Spindle CNC Chucker



MS60

Manual load type Single Spindle CNC Chucker

Basic Machine Specifications

		MW120 Single loader	MW120 Twin loader	MW120 Spindle isolation	MS60 Single loader	MS60 Manual load
Number of spindles		2	2	2	1	1
Distance between spindle centers		340 mm	340 mm	440 mm	—	—
Maximum chuck size	Standard	ø 165 mm (ø 6 inch)	ø 165 mm (ø 6 inch)	ø 165 mm (ø 6 inch)	ø 165 mm (ø 6 inch)	ø 165 mm (ø 6 inch)
	Option	ø 210 mm (ø 8 inch)	ø 210 mm (ø 8 inch)	ø 210 mm (ø 8 inch)	ø 210 mm (ø 8 inch)	ø 210 mm (ø 8 inch)
Number of turret stations	Standard	8 × 2	8 × 2	8 × 2	8	8
	Option	12 × 2	12 × 2	12 × 2	12	12
Spindle nose size		JIS A2-5	JIS A2-5	JIS A2-5	JIS A2-5	JIS A2-5
Diameter of spindle bore		ø 47 mm	ø 47 mm	ø 47 mm	ø 47 mm	ø 47 mm
Spindle diameter at front bearing mounting	Standard	ø 90 mm	ø 90 mm	ø 90 mm	ø 90 mm	ø 90 mm
	Option	ø 100 mm	ø 100 mm	ø 100 mm	ø 100 mm	—
Spindle speed range	Standard A	45 rpm ~ 4500 rpm	45 rpm ~ 4500 rpm	45 rpm ~ 4500 rpm	45 rpm ~ 4500 rpm	45 rpm ~ 4500 rpm
	Standard B	30 rpm ~ 3000 rpm	30 rpm ~ 3000 rpm	30 rpm ~ 3000 rpm	30 rpm ~ 3000 rpm	30 rpm ~ 3000 rpm
	Standard C	60 rpm ~ 6000 rpm	60 rpm ~ 6000 rpm	60 rpm ~ 6000 rpm	60 rpm ~ 6000 rpm	60 rpm ~ 6000 rpm
Spindle drive motor	Standard	7.5 kW/30min × 2	7.5 kW/30min × 2	7.5 kW/30min × 2	7.5 kW/30min	7.5 kW/30min
	Option	11 kW/30min × 2	11 kW/30min × 2	11 kW/30min × 2	11 kW/30min	—
Total weight		4,400 kg	4,600 kg	4,600 kg	2,500 kg	2,350 kg

MW & MS SERIES

10" Chuck Capacity Compact Machine Design

MW200 & MS100

(Chuck size 10")

MW200

Single loader type
Twin Spindle CNC Chucker



MS100

Single loader type
Single Spindle CNC Chucker

10" chuck capacity, compact and an ideal design for line planning with a floor contact width of only 1320 mm.

Basic Machine Specifications

		MW200 Single loader	MS100 Single loader
Number of spindles		2	1
Distance between spindle centers		440 mm	—
Maximum chuck size		ø 254 mm (ø 10 inch)	ø 254 mm (ø 10 inch)
Number of turret stations	Standard	10 × 2	10
	Option	12 × 2	12
Spindle nose size		JIS A2-6	JIS A2-6
Diameter of spindle bore	Standard	ø 63 mm	ø 63 mm
	Option	ø 73 mm	ø 73 mm
Spindle diameter at front bearing mounting	Standard	ø 100 mm	ø 100 mm
	Option	ø 110 mm	ø 110 mm
Spindle speed range	Standard A	24 rpm ~ 2400 rpm	24 rpm ~ 2400 rpm
	Standard B	35 rpm ~ 3500 rpm	35 rpm ~ 3500 rpm
Spindle drive motor	Standard	15 kW/30min × 2	15 kW/30min
	Option	22 kW/30min × 2	22 kW/30min
Total weight		7,200 kg	4,000 kg

Designed for Polly V Pulley Machining Applications

MW200 High power spindle type (Chuck size 12")

MW200
High power spindle type
Twin Spindle CNC Chucker

Basic Machine Specifications

		MW200 High power spindle type
Number of spindles		2
Distance between spindle centers		470 mm
Maximum chuck size		ø 305 mm (ø 12 inch)
Number of turret stations	Standard	10 × 2
	Standard	10 × 2
Spindle nose size		JIS A2-8
Diameter of spindle bore		ø 73 mm
Spindle diameter at front bearing mounting		ø 120 mm
Spindle speed range	Standard A	35 rpm ~ 3500 rpm
	Standard B	25 rpm ~ 2500 rpm
Spindle drive motor	Standard	22 kW/30min × 2
	Option	30 kW/30min × 2
Total weight		7,400 kg



Automated Line Planning for Large Size Work

MW300

(Chuck size 12")

Basic Machine Specifications

		MW300 Single loader
Number of spindles		2
Distance between spindle centers		560 mm
Maximum chuck size	Standard	ø 305 mm (ø 12 inch)
Number of turret stations	Standard	10 × 2
	Option	15 × 2
Spindle nose size		JIS A2-8
Diameter of spindle bore		ø 73 mm
Spindle diameter at front bearing mounting		ø 120 mm
Spindle speed range	Standard A	35 rpm ~ 3500 rpm
	Standard B	25 rpm ~ 2500 rpm
	Standard C	20 rpm ~ 2000 rpm
Spindle drive motor	Standard	18.5 kW/30min × 2
	Option	22 kW/30min × 2
Total weight		11,200 kg



MW300
Single loader type
Twin Spindle CNC Chucker

Heavy Duty, High Speed Disk Rotor Machining

MW400

(Chuck size 15")

Basic Machine Specifications

		MW400 Single loader
Number of spindles		2
Distance between spindle centers		560 mm
Maximum chuck size		ø 380 mm (ø 15 inch)
Number of turret stations	Standard	8 × 2
	Option	12 × 2
Spindle nose size		JIS A2-11
Diameter of spindle bore		ø 73 mm
Spindle diameter at front bearing mounting		ø 160 mm
Spindle speed range	Standard	35 rpm ~ 3000 rpm
	Option	35 rpm ~ 3500 rpm
Spindle drive motor	Standard	22 kW/30min × 2
	Option	30 kW/30min × 2
Total weight		13,200 kg



MW400
Single loader type
Twin Spindle CNC Chucker
Gantry loader is designed for extremely reliable, large size parts handling.

MD SERIES

Muratec, a global leader in twin-spindle turning machines introduces the MD Series Turning Centers. A new concept in process integration, flexible parts manufacturing and line planning. The new MD Series is designed for compact line operation, flexibility in manufacturing, versatility and easy set-up change.

MD series with it's compact footprint, is ideal for process integration of mid-size lot production

MD60 & MD120

(Chuck size 6", 8")

MD120

Single loader type
CNC Turning Center
(Twin-spindle)

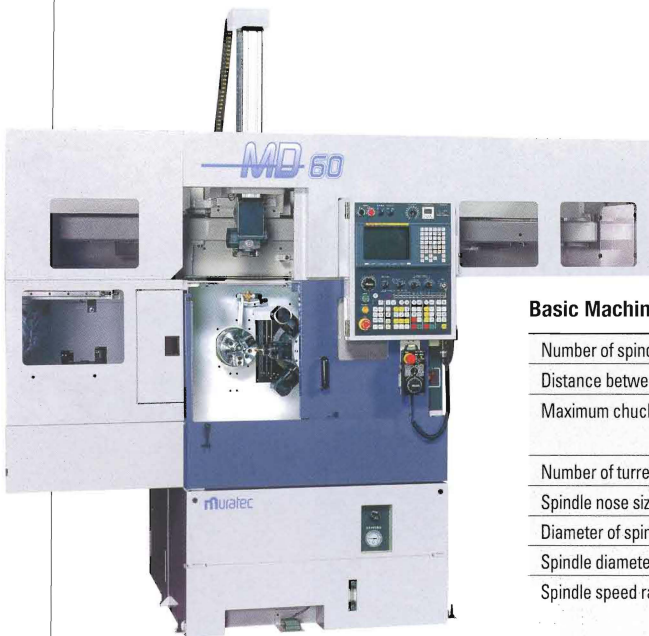

MD60

Single loader type
CNC Turning Center
(Single-spindle)

Basic Machine Specifications

		MD60 Single loader	MD120 Single loader
Number of spindles		1	2
Distance between spindle centers		—	340 mm
Maximum chuck size	Standard	ø 165 mm (ø 6 inch)	ø 165 mm (ø 6 inch)
	Option	ø 210 mm (ø 8 inch)	ø 210 mm (ø 8 inch)
Number of turret stations		10	10 × 2
Spindle nose size		JIS A2-5	JIS A2-5
Diameter of spindle bore		ø 47 mm	ø 47 mm
Spindle diameter at front bearing mounting		ø 90 mm	ø 90 mm
Spindle speed range	Standard A	45 rpm ~ 4500 rpm	45 rpm ~ 4500 rpm
	Standard B	30 rpm ~ 3000 rpm	30 rpm ~ 3000 rpm
	Standard C	60 rpm ~ 6000 rpm	60 rpm ~ 6000 rpm
Spindle drive motor	Standard	7.5 kW/30min	7.5 kW/30min × 2
	Option	11 kW/30min	11 kW/30min × 2
Live tool maximum speed		4000 rpm	4000 rpm
Live tool motor power		2.5 kW (9 Nm / continuous cutting)	2.5 kW (9 Nm / continuous cutting) × 2
Maximum Live tool size	Milling	ø 16 mm	ø 16 mm
	Tapping	M10	M10
Total weight		2,400 kg	5,000 kg

Live Tools and Process Integration

Contemporary manufacturing techniques such as lean manufacturing demand integrated processes, finishing the part on one machine, and compact line layouts to enable consistent and accurate production by eliminating in-process inventory.

The MD Series turning centers incorporate live tools on the turret as a standard feature with spindle drive positioning control. Live tools are available on all turret stations. The Live tool heads are available as an option to suit various requirements.

		MD120 / MD60	MD200 / MD100
Number of turret stations		10	10
Number of live tool stations		10	10
Maximum live tool RPM		4000 rpm	3000 rpm
Output Power		2.5 kW	4 kW
		(9 Nm / Continuous cutting)	(22 Nm / Continuous cutting)
Max. tool Shank size	Milling	ø 16 mm	ø 20 mm
	Tapping	M10	M16

Compact turning center of 10" chuck size

MD100 & MD200

(Chuck size 10")



MD200

Single loader type
CNC Turning Center
(Twin-spindle)

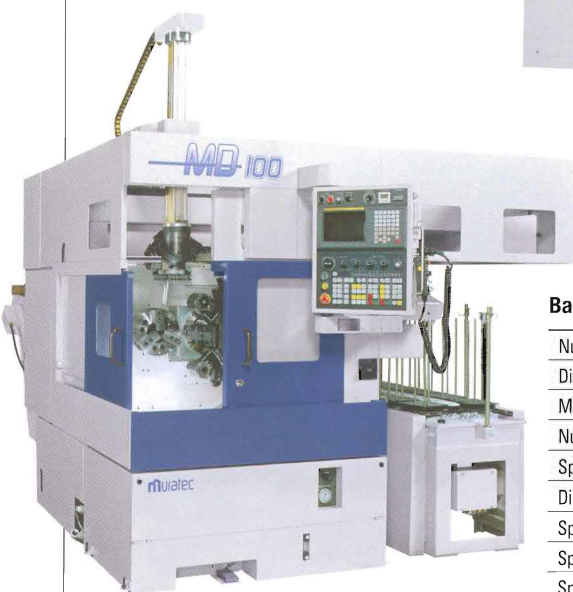

MD100

Single loader type
CNC Turning Center
(Single-spindle)

Basic Machine Specifications

	MD100 Single loader	MD200 Single loader
Number of spindles	1	2
Distance between spindle centers	—	440 mm
Maximum chuck size	ø 254 mm (ø 10 inch)	ø 254 mm (ø 10 inch)
Number of turret stations	10	10 × 2
Spindle nose size	JIS A2-6	JIS A2-6
Diameter of spindle bore	ø 73 mm	ø 73 mm
Spindle diameter at front bearing mounting	ø 110 mm	ø 110 mm
Spindle speed range	20 rpm ~ 2000 rpm	20 rpm ~ 2000 rpm
Spindle drive motor	Standard: 11 kW/30min Option: 22 kW/30min	11 kW/30min × 2 22 kW/30min × 2
Live tool maximum speed	3000 rpm	3000 rpm
Live tool motor power	4 kW (22 Nm/continuous cutting)	4 kW (22 Nm/continuous cutting) × 2
Maximum Live tool size	Milling: ø 20 mm Tapping: M16	ø 20 mm M16
Total weight	4,200 kg	7,400 kg



Cross live tool head
(MD60/120)



Face live tool head
(MD60/120)

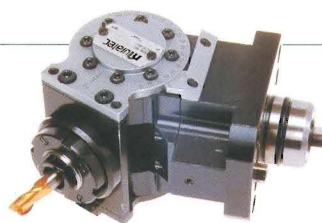

Angular live tool head
(MD60/120)

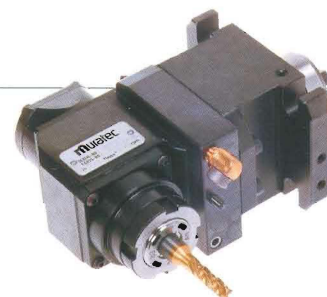

High speed face live tool head
(10,000 rpm spec)
(MD60/120)

Note: Please check tool dimensions when ordering.

MJ SERIES

Without changing design concept of MW and MS series, MJ60/ MJ100 enables shaft work machining with tailstock utilization.

MJ200 enables reduction of cycle time when combined with twin turrets and tailstock.

MJ series allows for automated shaft work line construction.

Turning machine with tailstock accommodates an automated line construction

MJ60, MJ100, MJ200

(Chuck size MJ60 : 6", 8"
MJ100, MJ200 : 10")

MJ100

Single loader type
CNC Turning Machine
with tailstock
(Single-spindle)



MJ200

Single loader type
CNC Turning Machine with tailstock
(Single-spindle, 2 turrets)

MJ60

Single loader type
CNC Turning Machine
with tailstock
(Single-spindle)



Basic Machine Specifications

		MJ60 Single loader	MJ100 Single loader	MJ200 Single loader
Number of spindles		1	1	1
Maximum chuck size	Standard	ø 165 mm (ø 6 inch)	ø 254 mm (ø 10 inch)	ø 254 mm (ø 10 inch)
	Option	ø 210 mm (ø 8 inch)	—	—
Number of turret stations	Standard	8	10	10 × 2
	Option	—	12	—
Spindle nose size		JIS A2-5	JIS A2-6	JIS A2-6
Diameter of spindle bore	Standard	ø 57 mm	ø 63 mm	ø 73 mm
	Option	—	ø 73 mm	—
Spindle diameter at front bearing mounting	Standard	ø 90 mm	ø 100 mm	ø 110 mm
	Option	—	ø 110 mm	—
Spindle speed range	Standard A	45 ~ 4500 rpm	24 ~ 2400 rpm	24 ~ 2400 rpm
	Standard B	30 ~ 3000 rpm	35 ~ 3500 rpm	35 ~ 3500 rpm
	Standard C	60 ~ 6000 rpm (7.5 kW only)	—	—
Spindle drive motor	Standard	7.5 kW/30min	15 kW/30min	22 kW/30min
	Option	11 kW/30min	22 kW/30min	—
Total weight		3,600 kg	5,400 kg	7,000 kg

More Flexible, Automated Line Planning

■ Designed to suit part size, shape and line tact time requirement

MW/MS/MD/MJ Series can be combined with single or twin spindle chucks or similar turning centers through common gantry loader system or independent loader system for maximum flexibility. This allows customers to design the line layout to suit exact requirements. Manufacturing line planning may incorporate a combination of single or twin spindle chucks with single or twin spindle turning centers. This line flexibility allows for turnaround operations, both spindles same operation, three spindles same operation, four spindles same operation, or a line where operations are divided for turning on chucks and live tool operations on turning centers. This type of line planning boosts the production capacity of the plant with compact layout and improved parts quality.



MW120 and MS60 Combination for 3rd operation solution.
MW120+MS60

■ Various system configurations to suit your requirements

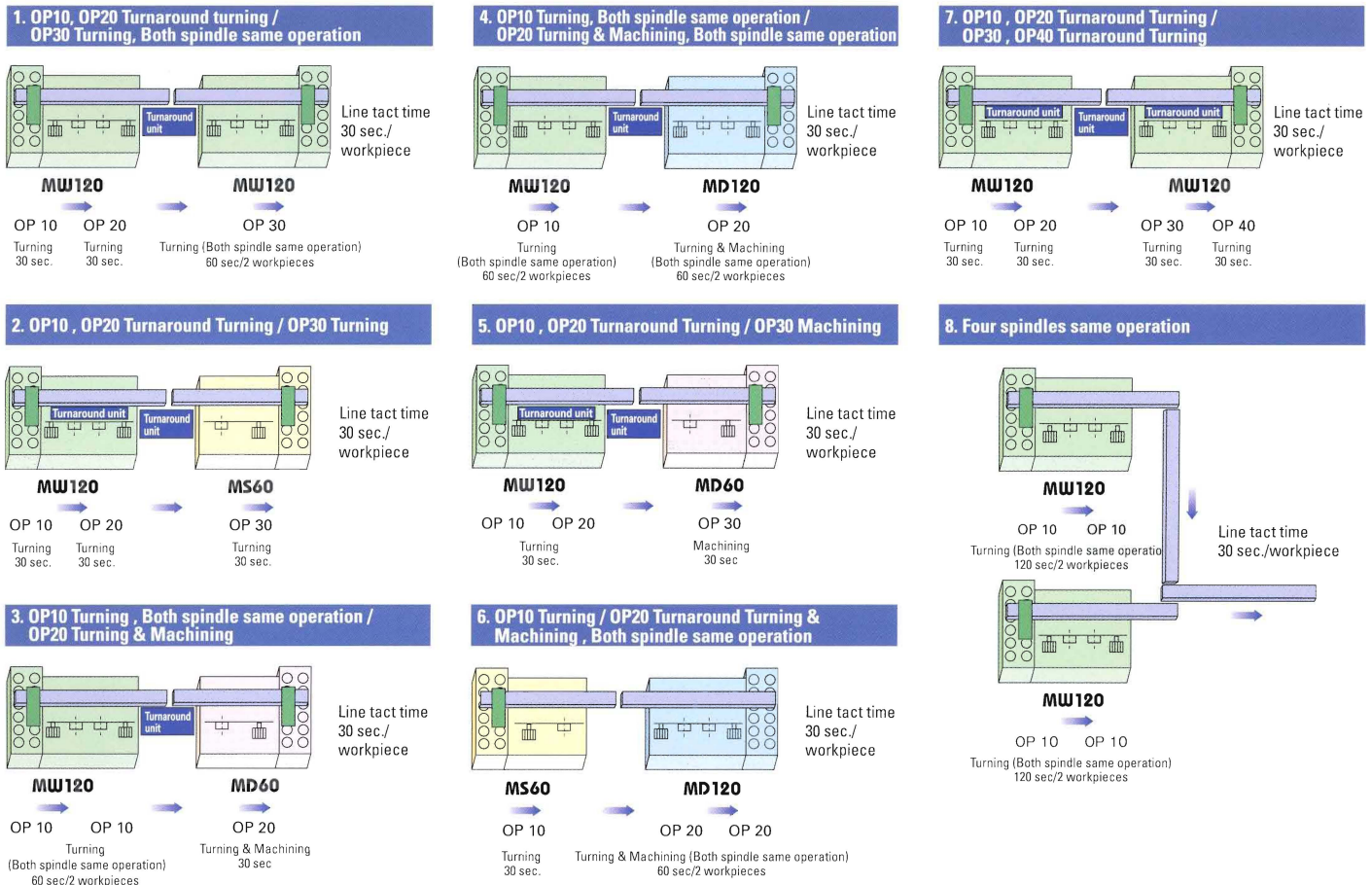

* These are few system configuration examples. A wide variety of system configuration is possible to meet various customer needs.

INTELLIGENT CNC GANTRY LOADER

An Integral, Intelligent 3-Axis CNC Gantry Loader Offers Versatile Automation

■ Safety during loader crash

Abnormal load detection function immediately stop axes movement and track back function reverse the axis movement

■ Loader Re-start from any Position

Loader cycle can be restarted from interrupted position

■ Work discharge for Work location NG Work

Auto unloading feature in case of NG work

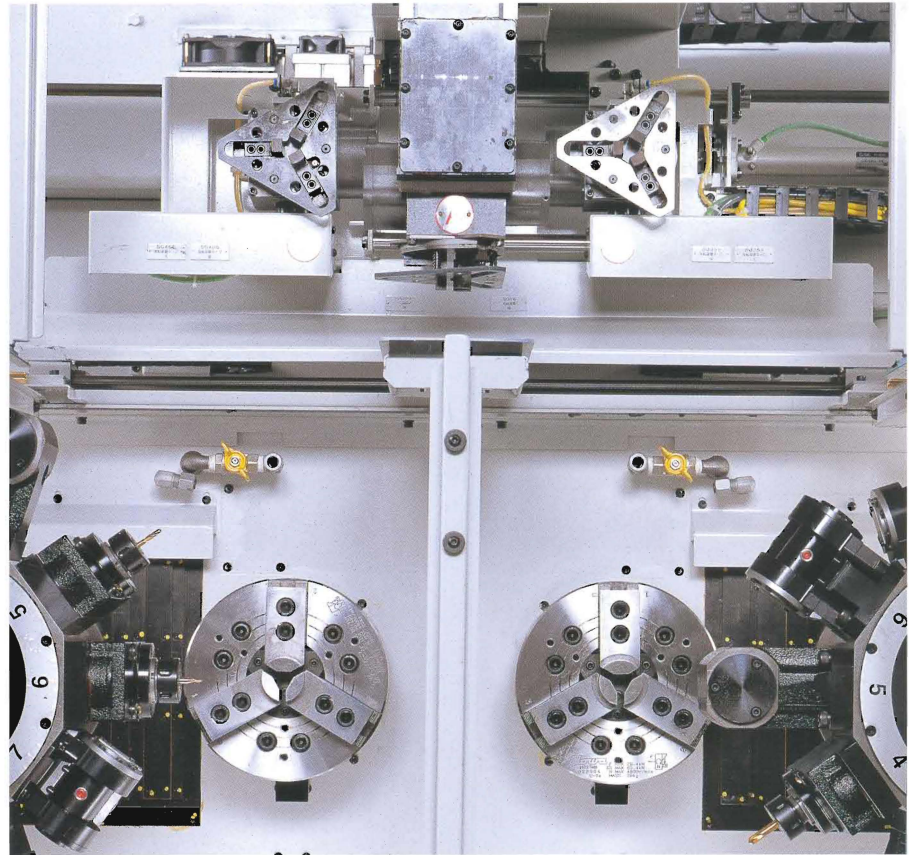

High Quality Performance with CNC Gantry Loader

■ Gantry Dual Gripper Swivel Head

Muratec's fully programmable 3-Axis CNC gantry loader allows quick load/ unload of various shape parts, quick palletizing and work transfer to various locations as per system requirement. It is fast, simple, economical and easily changed. Programs are recalled for fast changeover.

■ Remote Pendant Operator Panel

Operator can quickly position and set teach points at all pick and place junctions with this portable hand held unit. This panel includes a manual pulse generator.

■ Easy Loader Programming

The loader travel pattern is well defined with system requirement. By just establishing teach points on the variables, the loader program is prepared.

(EX.: MD200)

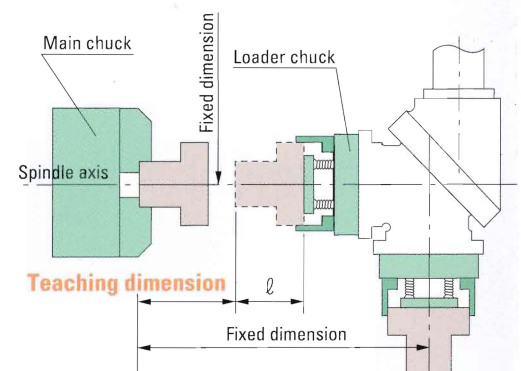
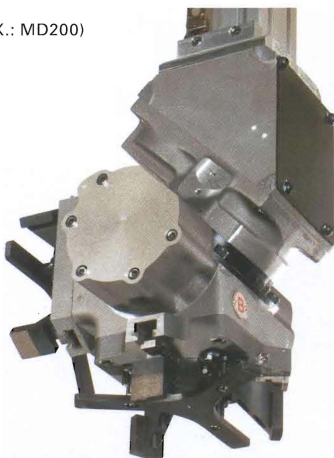

Loader Cycle

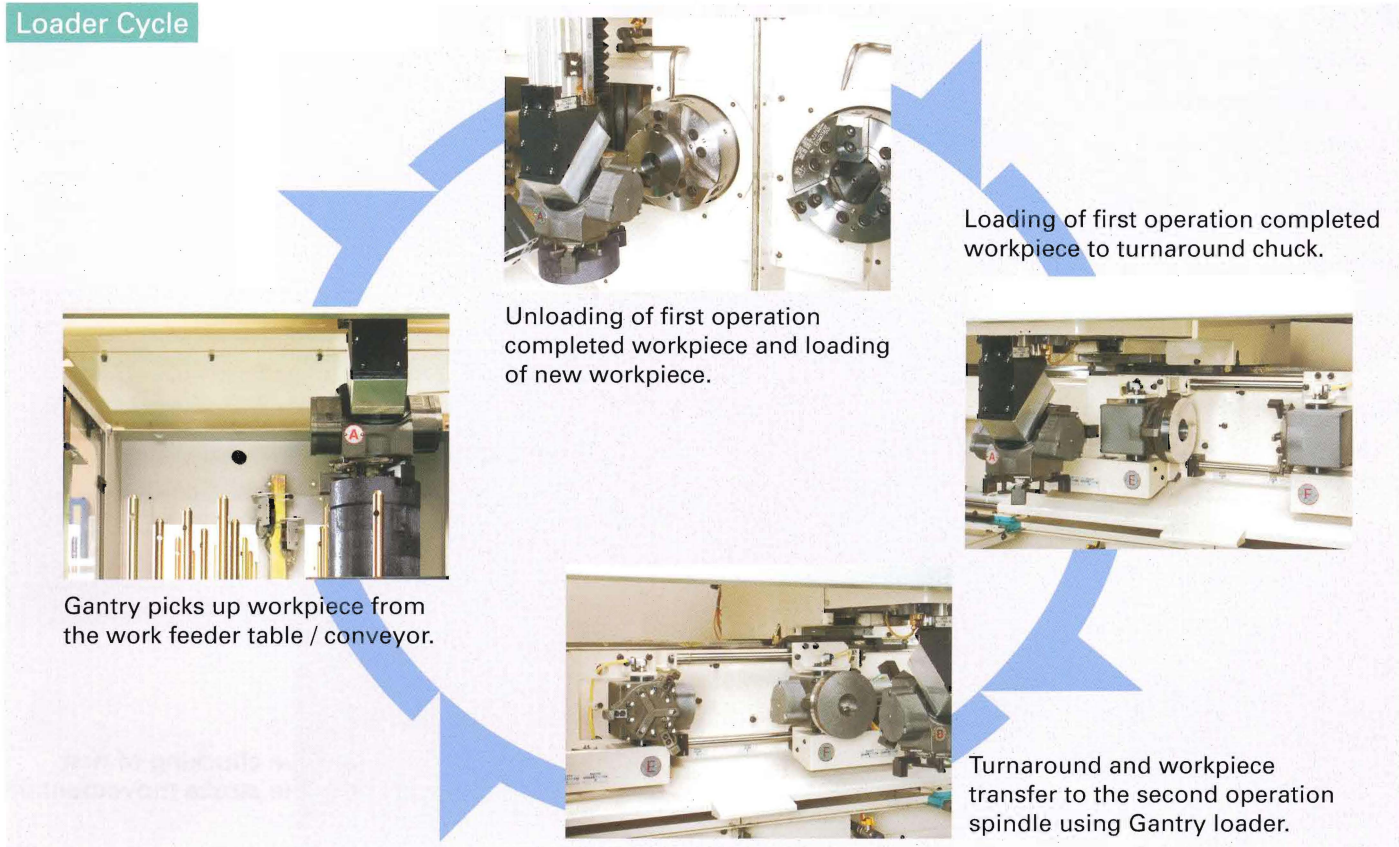

■ Loader Re-start Function

Intelligent gantry loader memorizes the working positions and the work status during operation. The loader cycle can be restarted from any interrupted position when auto cycle is halted due to a machine alarm, caution messages or manual intervention.

■ Abnormal Load Detection

Abnormal load detection function detects abnormal load for all turret and loader axes. Any crash due to operator's error, programming error etc. will minimize the severity of damage to the machine.

■ Quick Workpiece Palletizing

Three-axis, Swivel head gantry loader allows for easy and quick palletizing of different shape and size parts through flexible teaching positions. The loader feature allows work loading/unloading on stacking, Non-stacking type work feeders, Conveyors, Positioning units, Chutes etc. and irregular shape parts loading/unloading similar to robot hand.

■ Track Back Function

Axis Track-Back function enables reversing of the turret and loader axis movement direction. The axis is then retracted by 0.5 mm. This occurs when an abnormal load (100% motor load) is detected during cutting or axis movements.

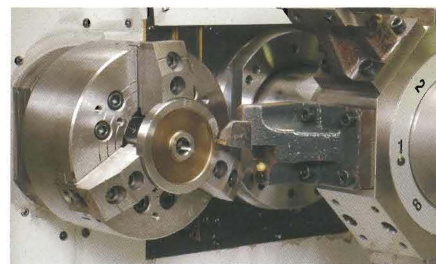

Turret Axis Track Back

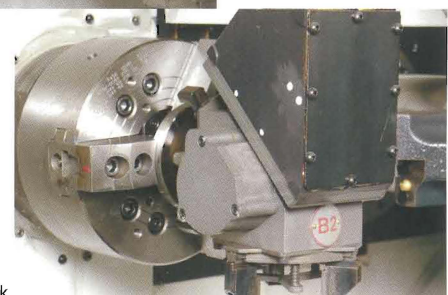

Gantry Loader Track Back

State-of-art Automation Know-how Designed

Chip disposal

■ Chip conveyor

(Hinge type / Spiral type / Screw type / Magnet-scraper type)

Muratec offers an optimum model of chip conveyor to suit your requirements based on materials and chip shapes.

■ Chip crusher

Chip crusher finely crushes long and bulk chips for ease of maintenance.

■ Flushing inside machine

Flushing inside machine is effective in chip discharge for casting and aluminum workpiece.

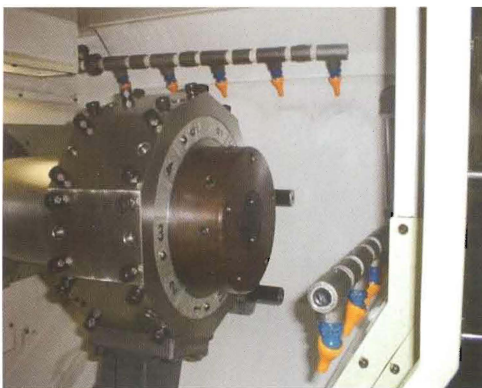

Chip disposal and coolant

■ Coolant filter

Coolant filter removes fine chips from coolant to prevent a filter from clogging.

■ Coolant level detector

An alarm is displayed when detecting coolant tank low level.

■ Coolant blow/ Air blow

Various blows such as coolant, air, and mixing blow are sprayed from suitable points in accordance with workpiece shapes and chip conditions.

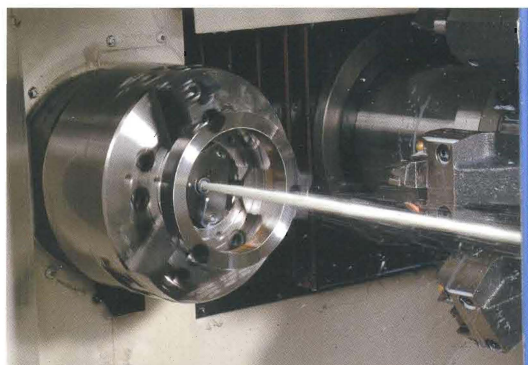

Quality check

■ Work load re-try function

If proper work location is not achieved, an automatic retry sequence will occur as follows: Workpiece unload, rotating chuck blow-off and part reload. If attempts at automatic reload fail within parametric set number of retries the workpiece is deposited in NG chute and the cycle is continued with a new workpiece.

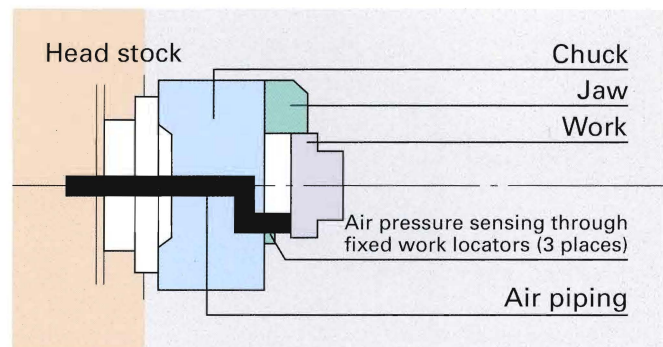

■ Work clamp sensor

This function confirms positive chucking of first operation by sensing complete stroke movement of the actuator.

■ Soft quality check counter

Finished workpieces every preset numbers are periodically discharged to outside machine.

■ Tool monitor

Wear or breakage of tools is detected based on load information obtained from servomotor without installing an external sensor.

■ High/ low chuck pressure switch

Chuck pressure is switched between roughing and finishing. Switching chuck pressure minimizes work deformation. It is ideal for high precision cutting.

for Unmanned Production



Work environment and Maintenance

■ Oil mist removal unit

This unit protects a work environment by collecting "Oil mist" in the cutting area within the machine.

■ Auto power off

Main breaker is automatically turned OFF after termination of an automatic operation at night.

■ Circuit for power saving

In machine waiting condition, wasted power consumption is reduced by turning hydraulic pump and servomotor OFF.

■ Installing each unit on the front side of the machine

Frequently used and confirmation units are placed on the front side of the machine.



Related to loader

■ Twin Gantry loader

Two loaders can be access to both right and left chucks.

This is truly effective for short cycle work.

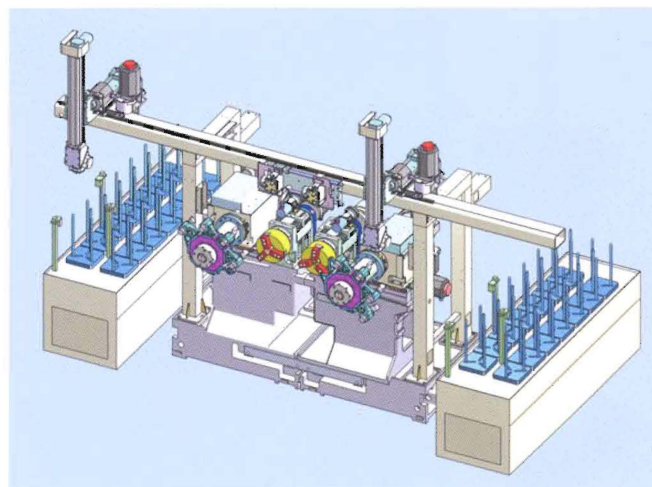

■ Special unit specification

(Single loader & Transfer loader)

One of the two loaders is used exclusively for transfer.

■ Loader cycle of starting from midpoint

When a program stops, the system stores its work status where the machine chuck or the loader chuck grips workpiece. On the next startup, operation begins with the perfect cycle.

Stocker / Gauge Unit / Peripheral device

Standard Stocker



WF14L-160II

	Number of pallets	Stack height	Weight of workpiece	Workpiece diameter
WF10L-160II	10	450 mm	40 kg/pallet	ø 30 mm ~ ø 160 mm
WF14L-160II	14	450 mm	40 kg/pallet	ø 30 mm ~ ø 160 mm
WF20L-160II	20	450 mm	40 kg/pallet	ø 30 mm ~ ø 160 mm
WF30L-160II	30	450 mm	30 kg/pallet	ø 30 mm ~ ø 160 mm
WF14L-280II	14	400 mm	50 kg/pallet	ø 60 mm ~ ø 280 mm

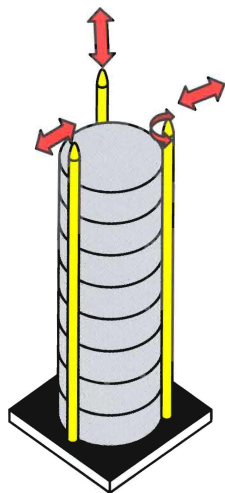
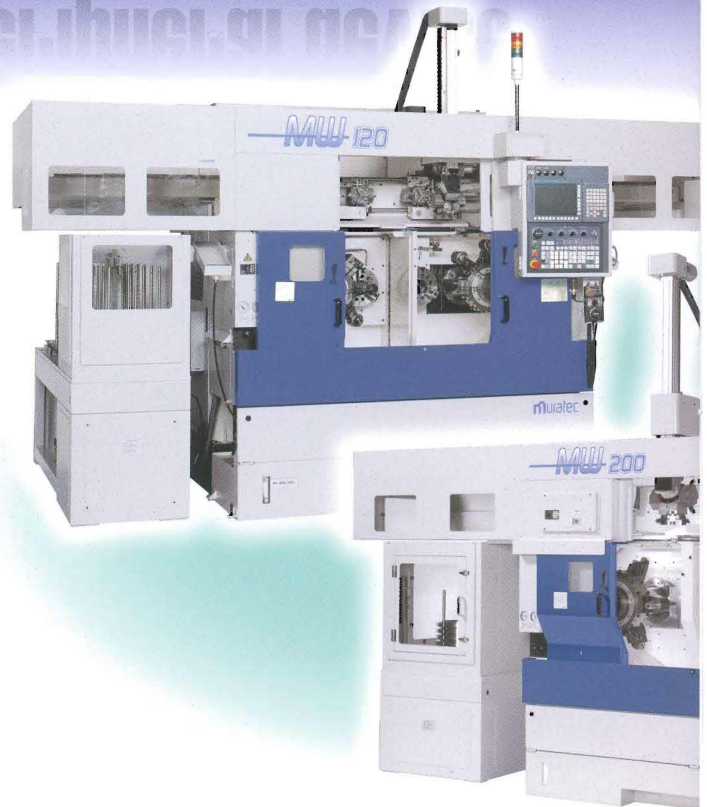

Standard 3 poles type

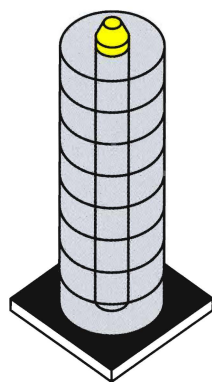

Center pole type

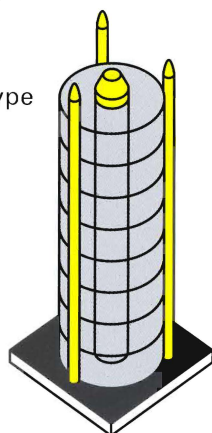

3 poles & center pole type

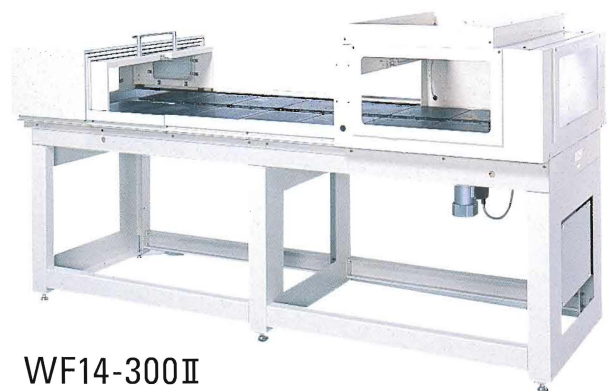

WF14-300II
Non-stacking Type

	Number of pallets	pallet size	workpiece Weight
WF14-300II	14	310 mm × 310 mm	30 kg/pallet
WF24-300II	24	310 mm × 310 mm	25 kg/pallet

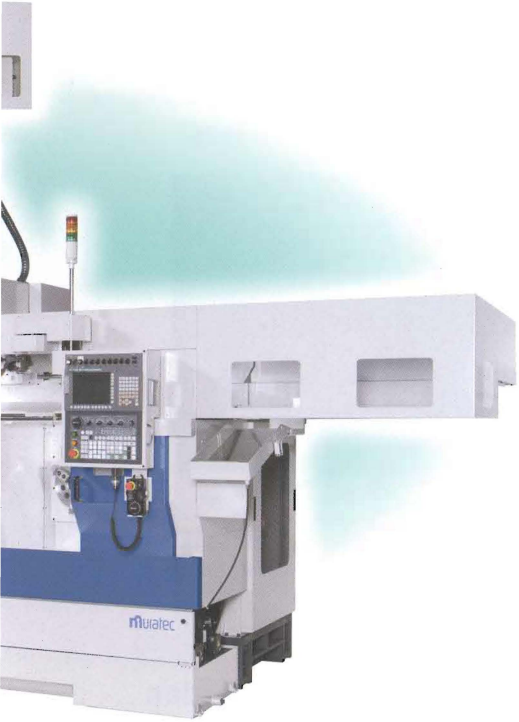

Stocker / Gauge Unit / Peripheral device

- Inlet/Outlet Conveyor
- Wash Unit
- Tray Changer
- Indexing pallet feeder table
- Workpiece checking Unit
- Aslope stocker
- Part orientation
- Post Process Gauge
- Inlet/Outlet shuttle
- Direct Post Process Gauge
- Parts Feeder
- Turn-around Unit
- Inlet/Outlet chute
- Deburring Unit
- Interface for special unit
- Auto Tray Changer



Wash Unit

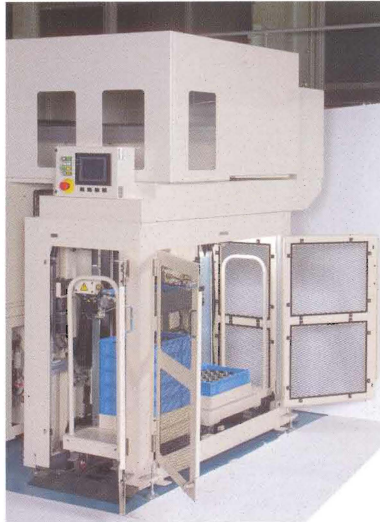

Tray Changer

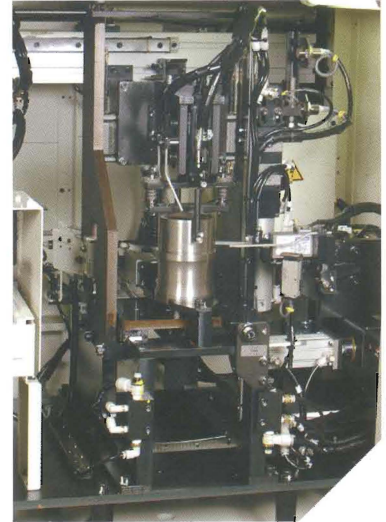

Post Process Gauge

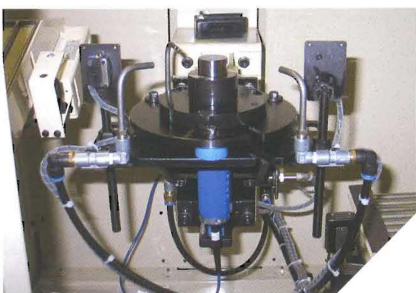

Direct Post Process Gauge



Parts Feeder



Auto Tray Changer

Advanced user-friendly functions and displays



The operation panel is at a convenient height on the right side of the machine. The panel can rotate 90 degrees. Buttons are clearly classified and logically grouped under; left spindle, right spindle (Twin spindle chucks) and loader. Distinction is also made for manual and automatic. Functions and symbolic button labels are international symbols.

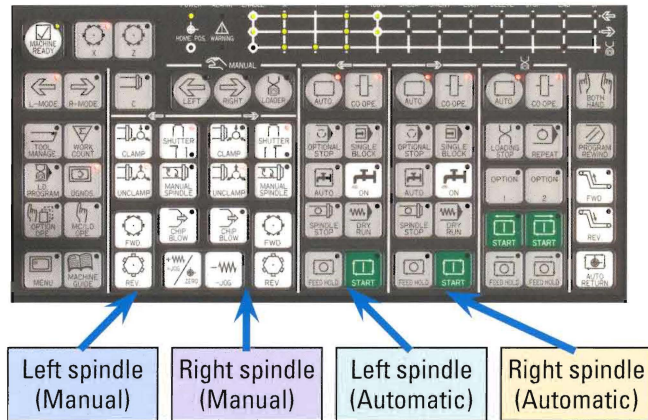

Auto Tool Shift Function (Option)

OPR. PATTERN	TOOL NO. (START)	TOOL NO. (END)	TOOL COUNT	TOOL GROUP	SHIFT MODE
1	1	10	1	2000	0
2	11	20	3	2000	0
3	21	30	5	2000	0
4	41	50	7	2000	0

Spare or redundant tools can be activated by tool count or tool breakage detection. Different part programs based on five patterns can be set for auto tool shift function. Each pattern has 8 tool groups with 15 tool shift settings. Standard and rotation tool shift modes are available to meet different production requirements. This tool shift option is useful for continuous and unattended type production.

Abnormal Load Detection

The MW/MS/MD/MJ series machines use the abnormal load detection function to detect abnormal load on all turret and loader axes. Any crash due to operator's mistake, programming mistake etc. will minimize damage to the machine by retracting the axis.

Tool Monitor (Option)

MONITOR PATH	LEVEL	SYSTEM	SCALE	SCALE	SCALE
X	0	180	X	0	13
L	2	231	R	2	0
S	0	0	S	0	0

The MW/MS/MD/MJ series machines incorporate optional 3-stage (Upper, Lower level & Zero cut) tool monitor function to check abnormal loads. The cutting load on individual axis is monitored for each cutting process. Emergency stop, Cycle stop or Auto running continue levels can be set for different cutting loads. In combination with optional Auto Tool Shift function, spare tool can be activated when cutting load exceeds predetermined level. This tool monitor is useful for continuous and unattended operations.

Diagnostics Function

ALARM HISTORY	DATE/TIME	ALARM NO.	ATTRIBUTE
ALM01	2006/03/31 09:00:25	001/200	
ALM02	2006/02/15 15:44:31	002/200	
ALM03	2006/02/15 15:44:25	003/200	
ALM04	2006/02/15 15:44:25	004/200	
ALM05	2006/02/15 15:44:24	005/200	

A display alarm will be accompanied by diagnostics explanation. A history of the last 200 alarms is maintained and can be accessed on the display.

Machine Guide

START CONDITION	STATUS	START CONDITION	STATUS
DOOR/COVER	OK	LOADER X-AXIS POSITION	OK
TURRET X-AXIS POSITION	OK	LOADER Y-AXIS POSITION	OK
TURRET Z-AXIS POSITION	OK	LOADER Z-AXIS POSITION	OK
MAIN CHECK	OK	B CHECK	OK
NO SPINDLE STOP	OK	SWIVEL POSITION	OK
AUTO MODE (CREDIT OFF)	OK	FRONT DOOR/COVER	OK
SHUTTER	OK	MEMORY MODE	OK
FTI CHECK	OK	NO ALARM	OK
SENSOR REVERSE	OK	F CHECK	OK
TOOL COUNTER UP	OK	F CHECK	OK
WORK STATE	OK	E/F TURN	OK

This function helps to check the machine and loader status quickly in combined display and guides the operator to restore the machine status for automatic operations or machine zero set.

Main Spindle Output Power Characteristics

MW50

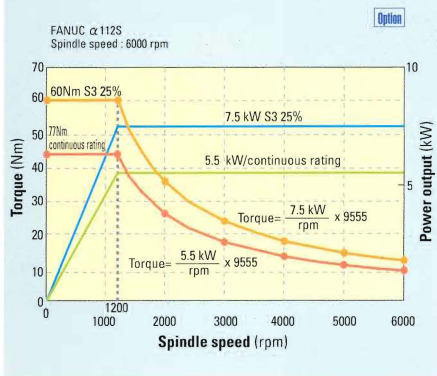
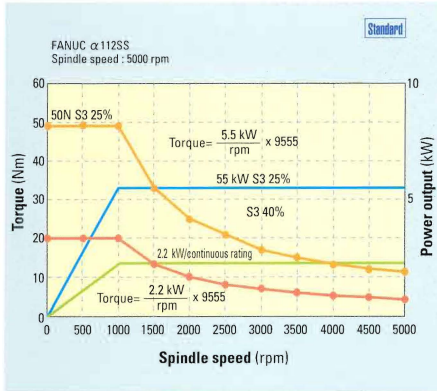

MW100 / MS50

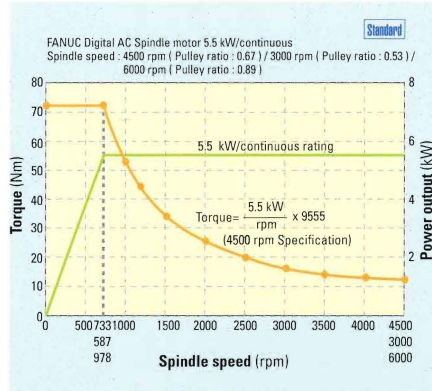

MW200 / MS100

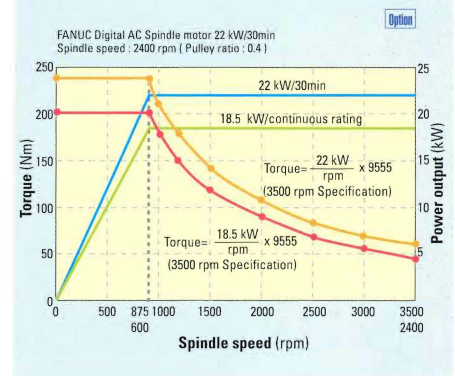
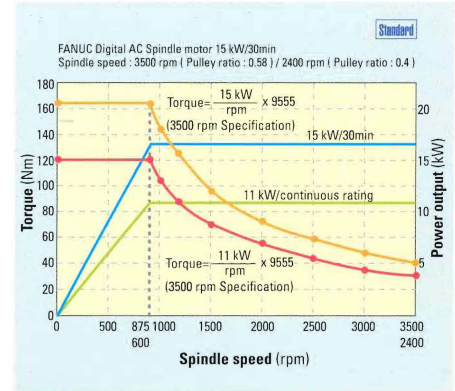

MW300

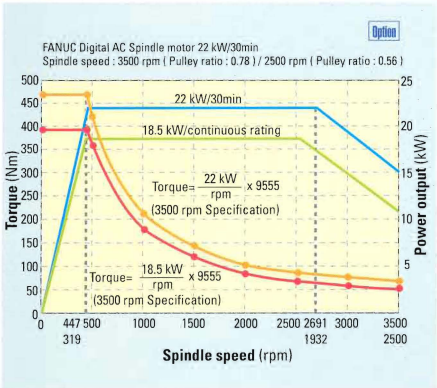
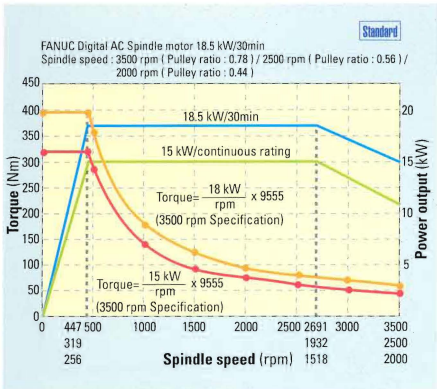

MW120 / MS60

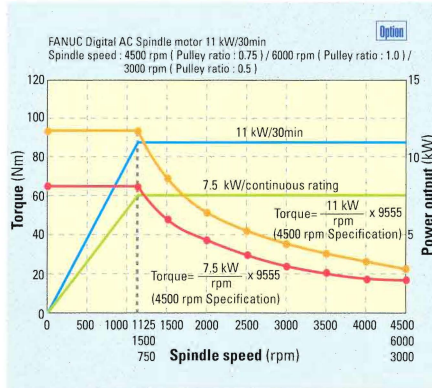
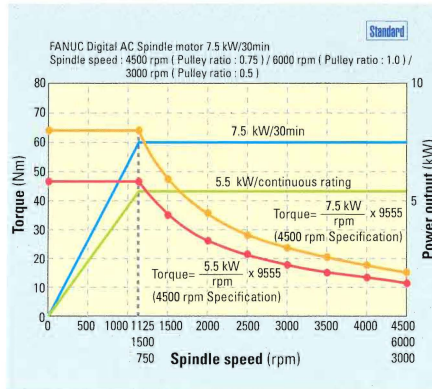

MW200 High power spindle type

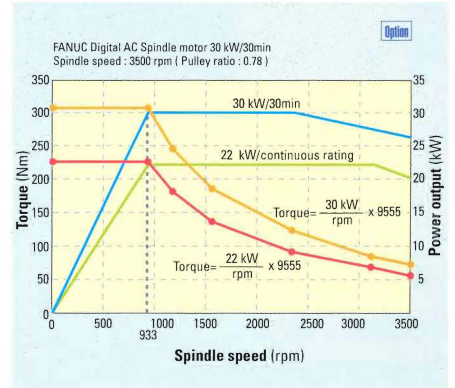
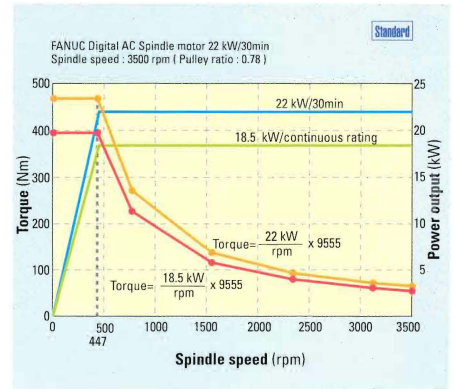

—●— 30 min rating
—●— Continuous rating

Main Spindle Output Power Characteristics

MW400

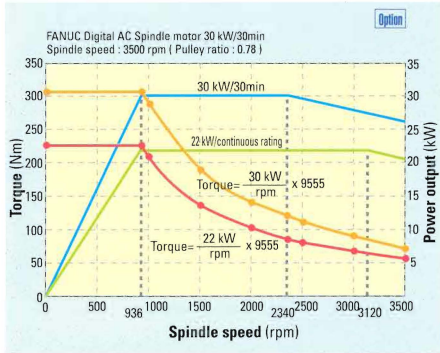
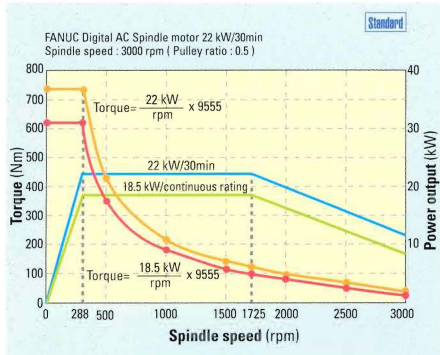

MD120 / MD60

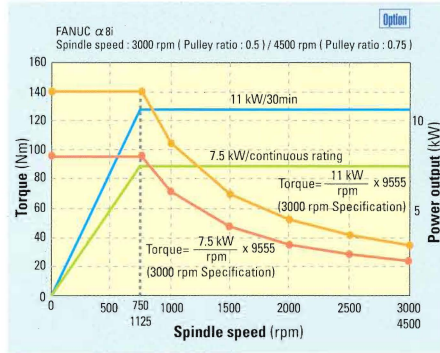
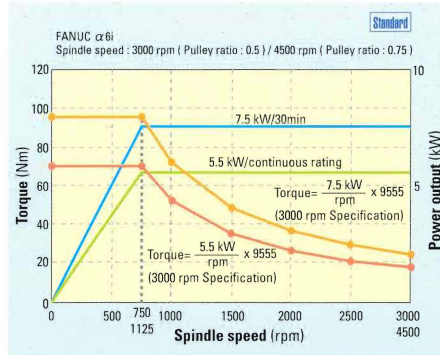

MD200 / MD100

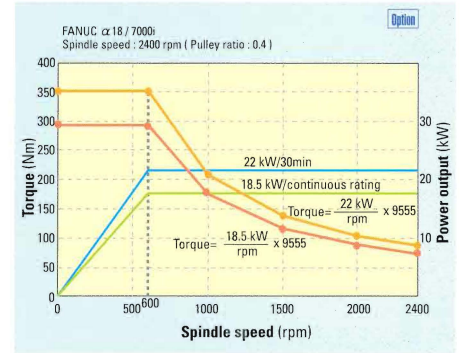

MJ60

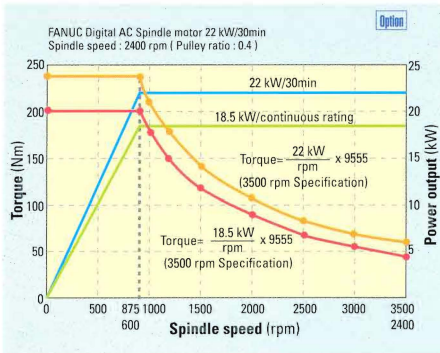
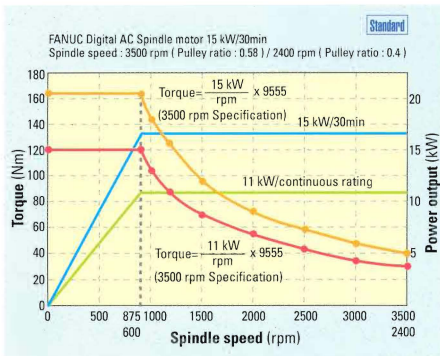

MJ100

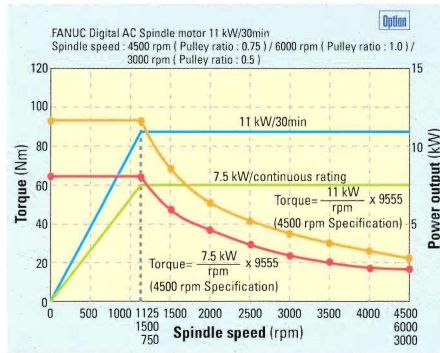
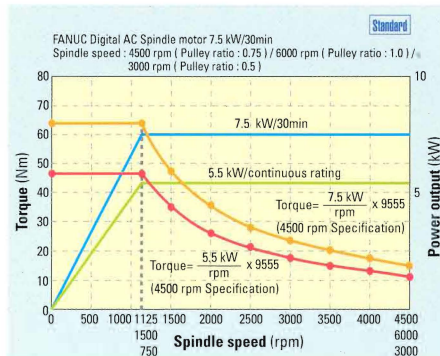

MJ200

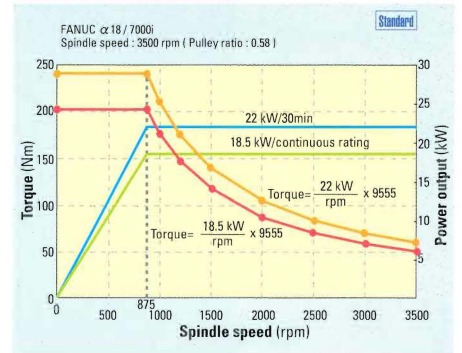
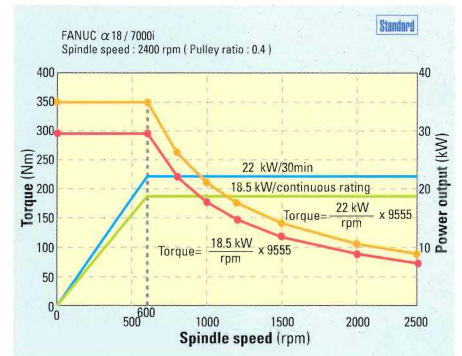

Live Tool Output Power Characteristics

MD120 / MD60

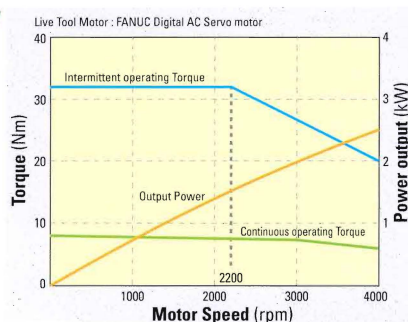

MD200 / MD100

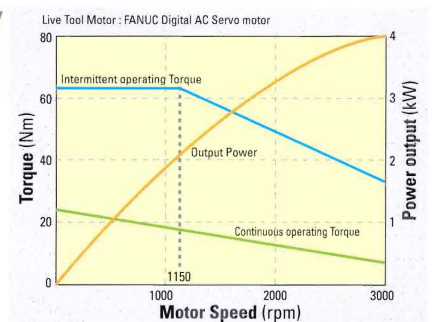

Tooling System

MW / MS
MJ

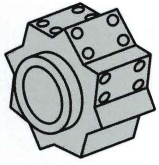

8 Station Turret
: MW100, MS50



8 Station Turret
: MW120, MS60,
MW400, MJ60

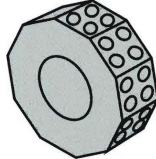

10 Station Turret
: MW200, MS100, MW300,
MJ100, MJ200



12 Station Turret
: MW120, MS60 MW200,
MS100, MW400, MJ100



15 Station Turret
: MW300

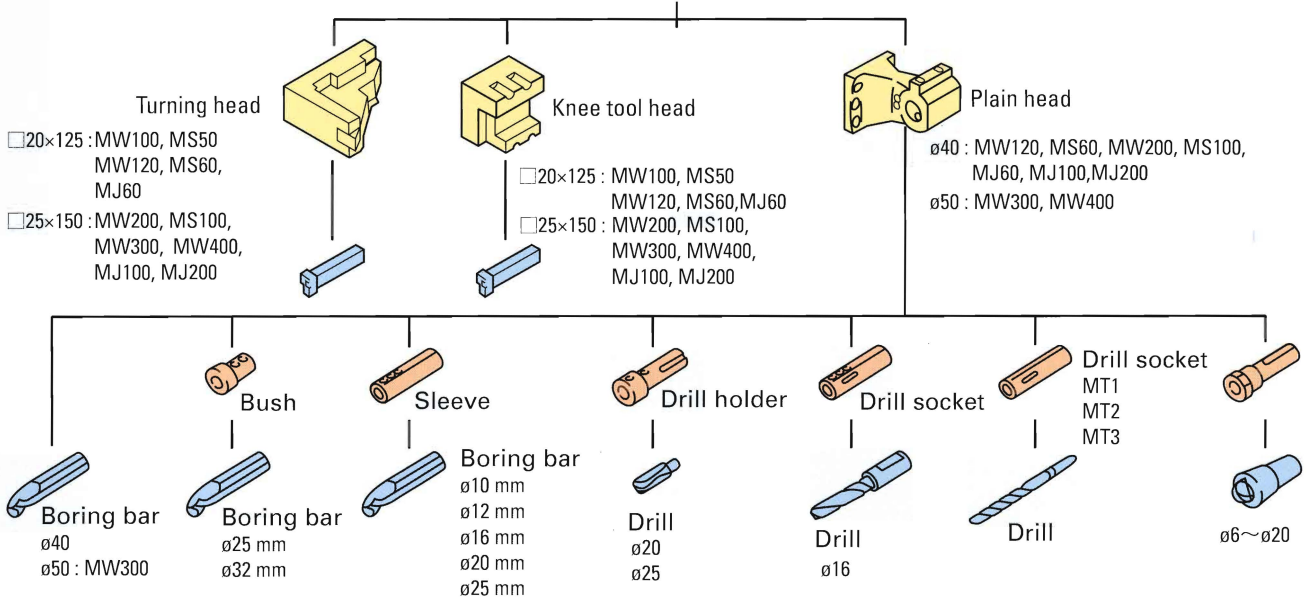

MD

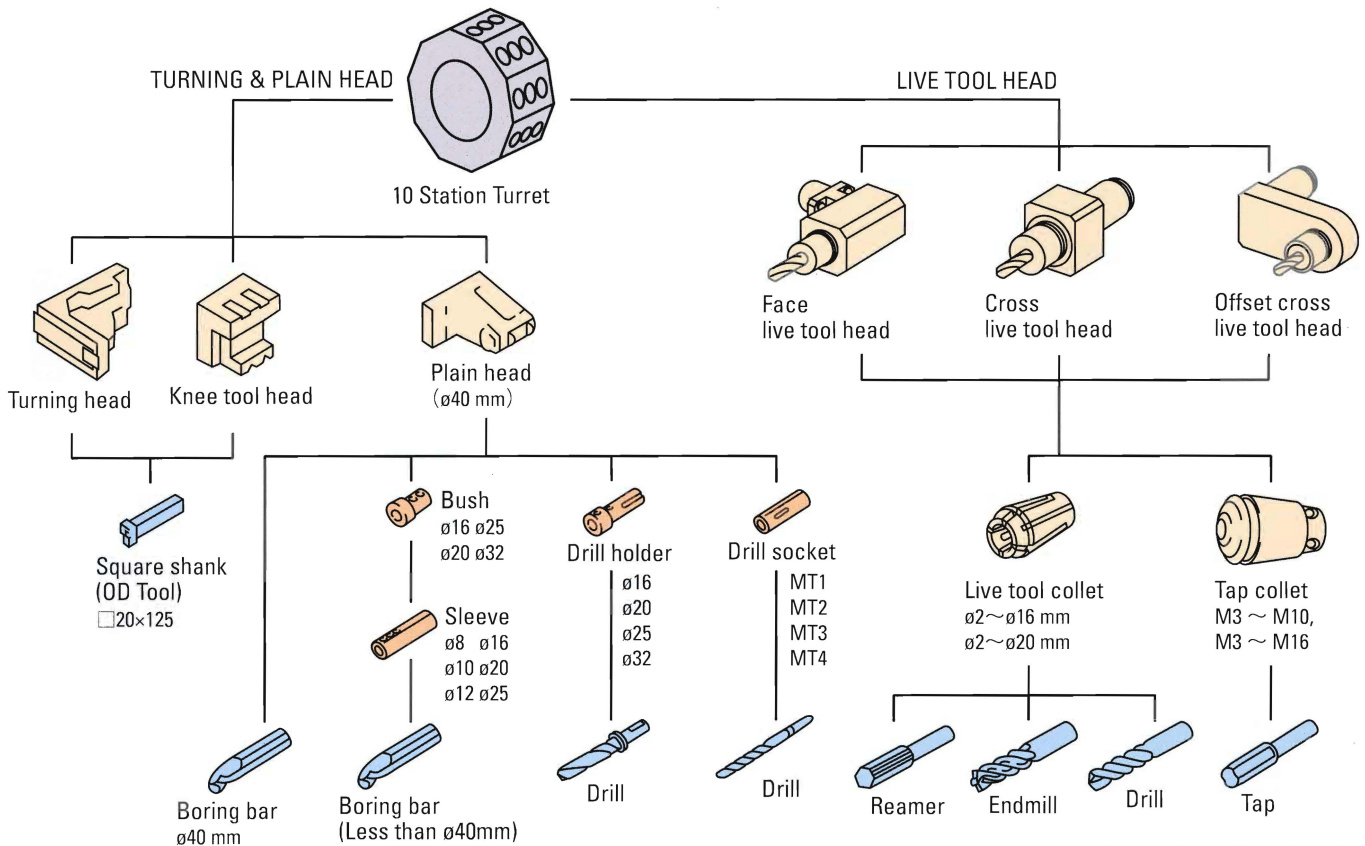

Note: Angular live tool head is available.

MW400 (8 Station Turret)

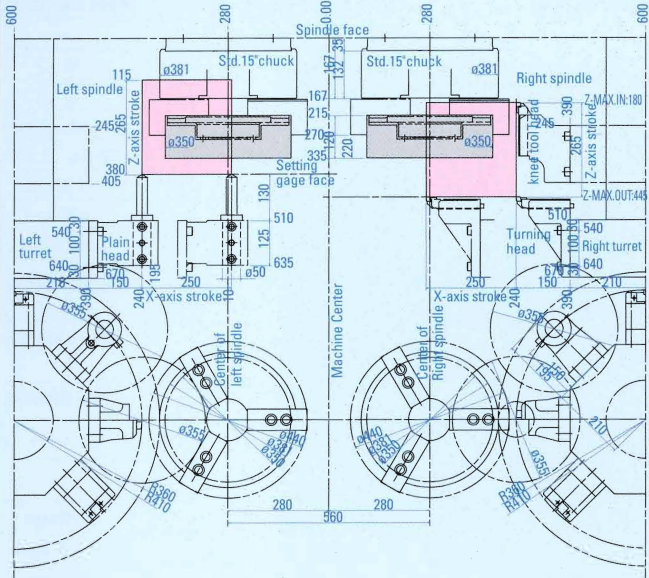

MD200 / MD100 (10 Station Turret)

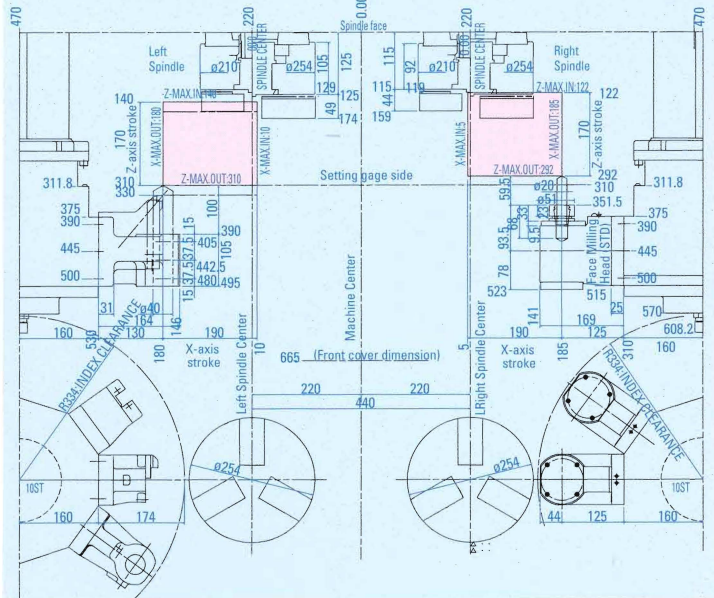

MW400 (12 Station Turret)

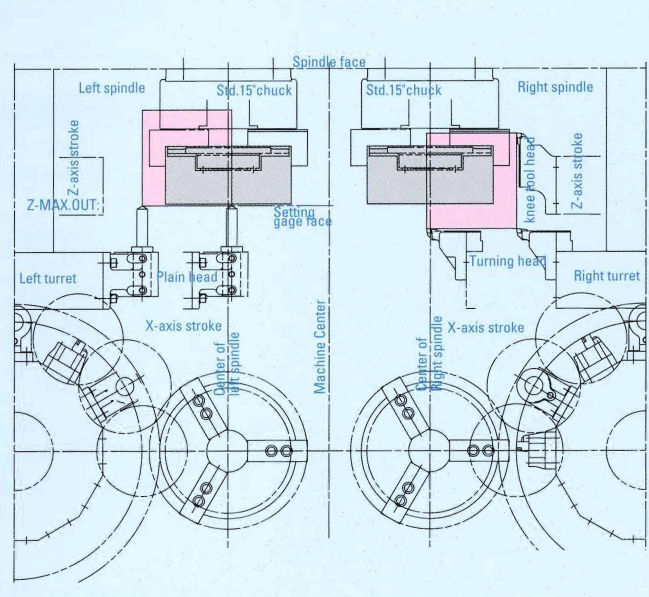

MJ60 (8 Station Turret)

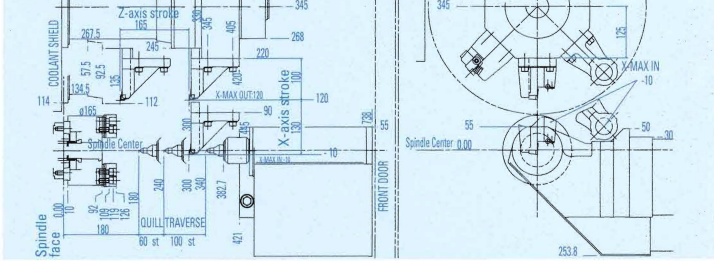

MJ100 (10 Station Turret)

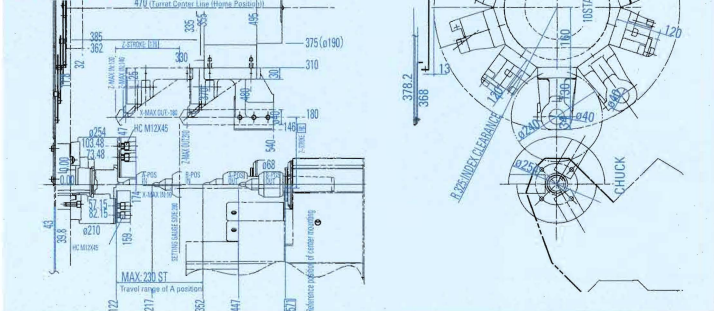

MD120 / MD60 (10 Station Turret)

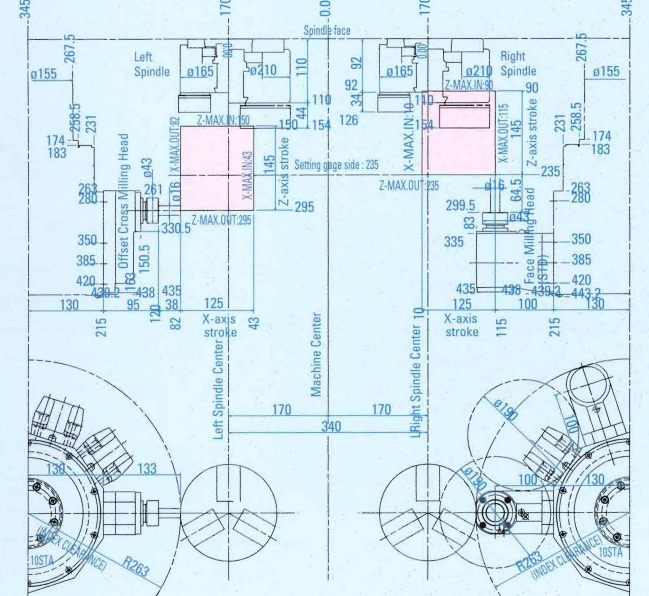

MJ200 (10 Station Turret)

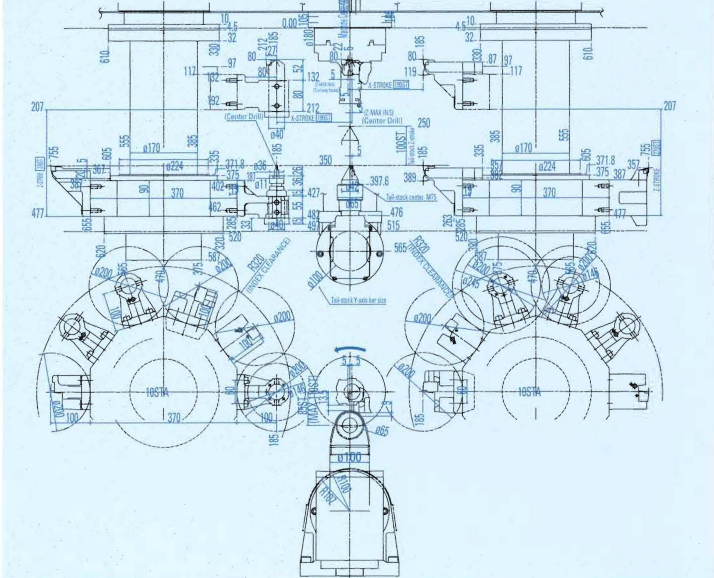

Specifications

Basic Machine Specifications

		MW50	MW100	MW120	MW200
Maximum chuck size	Standard	ø 165 mm (6 inch)	ø 165 mm (6 inch)	ø 165 mm (6 inch)	ø 254 mm (10 inch)
	Option	—	—	ø 210 mm (8 inch)	—
Number of turret stations	Standard	Tool plate × 2 Width : 270 mm	8 × 2	8 × 2	10 × 2
	Option	—	—	12 × 2	12 × 2
Specification of cutting axes for turret (Stroke/Max. speed)	X-axis	200 mm 18 m/min	130 mm 24 m/min	130 mm 24 m/min	190 mm 24 m/min
	Z-axis	200 mm 24 m/min	110 mm 24 m/min	145 mm 24 m/min	170 mm 24 m/min
Use tool	O.D. tool	□ 20 mm	□ 20 mm	□ 20 mm	□ 25 mm
	I.D. tool	ø 25 mm	ø 40 mm	ø 40 mm	ø 40 mm
Spindle drive motor	Standard	5.5 kW/30min × 2	5.5 kW/30min × 2	7.5 kW/30min × 2	15 kW/30min × 2
	Option	7.5 kW/30min × 2	—	11 kW/30min × 2	22 kW/30min × 2
	Option	—	—	—	—
Spindle speed range	Standard A	50 ~ 5000 rpm	45 ~ 4500 rpm	45 ~ 4500 rpm	24 ~ 2400 rpm
	Standard B	60 ~ 6000 rpm	30 ~ 3000 rpm	30 ~ 3000 rpm	35 ~ 3500 rpm
	Standard C	—	60 ~ 6000 rpm	60 ~ 6000 rpm (7.5 kW only)	—
Spindle diameter at front bearing mounting	Standard	ø 80 mm	ø 80 mm	ø 90 mm	ø 100 mm
	Option	—	—	ø 100 mm	ø 110 mm
Diameter of spindle bore	Standard	ø 32 mm	ø 47 mm	ø 47 mm	ø 63 mm
	Option	—	—	—	ø 73 mm
Spindle nose size		Flat nose	JIS A2-5	JIS A2-5	JIS A2-6
Foot print		W1220 mm × D1985 mm	W1550 mm × D1650 mm	W1900 mm × D1810 mm	W2360 mm × D2130 mm
Total weight		3,400 kg	3,500kg	4,400 kg	7,200 kg

Gantry loader Specifications

		MW50	MW100 / MS50 (Small parts spec)	MW100 / MS50 (Medium parts spec)	MW120 / MS60
Loader workpiece handling capacity (weight)		0.5 kg × 2	0.7 kg × 2	2.0 kg × 2	3.0 kg × 2
Loader workpiece handling capacity (size)		ø 50 mm × 50 mm	ø 60 mm × 40 mm	ø 80 mm × 60 mm	ø 120 mm × 80 mm
X-axis (Left/Right)	Stroke	The gantry loader X-axis stroke adjustable to layout.			
	Max. Speed	180 m/min	150 m/min	150 m/min	160 m/min
Y-axis (Up/Down)	Stroke	360 mm	360 mm	435 mm	550 mm
	Max. Speed	130 m/min	120 m/min	120 m/min	120 m/min
Z-axis (Front/Rear)	Stroke	95 mm	95 mm	135 mm	205 mm
	Max. Speed	55 m/min	55 m/min	55 m/min	35 m/min
α-axis	Stroke	180°	180°	180°	180°
	Cycle time	0.4 sec/180°	0.4 sec/180°	0.6 sec/180°	0.6 sec/180°
Jaw Stroke	Loader/ T/A unit	ø 12 mm	ø 12 mm	ø 30 mm	ø 30 mm
Standard loading time		5.4 sec	6.0 sec	7.0 sec	7.0 sec

CNC STANDARD SPECIFICATIONS

Simultaneous position and feed control	MW series (without MW300)	3 axes (Turret - X1, Z1, turret rotation) + 3 axes (Turret - X2, Z2, turret rotation) + 3 axes (Loader - X, Y, Z)
	MW300	2 axes (Turret - X1, Z1) + 2 axes (Turret - X2, Z2) + 3 axes (Loader - X, Y, Z)
	MS series	3 axes (Turret - X1, Z1, turret rotation) + 3 axes (Loader - X, Y, Z)
	MD60, MD100	3 axes (Turret - X1, Z1, turret rotation) + 3 axes (Loader - X, Y, Z)
	MD120, MD200	3 axes (Turret - X1, Z1, turret rotation) + 3 axes (Turret - X2, Z2, turret rotation) + 3 axes (Loader - X, Y, Z)
	MJ60, MJ100	3 axes (Turret - X1, Z1, turret rotation) + 3 axes (Loader - X, Y, Z)
	MJ200	2 axes (Turret - X1, Z1) + 2 axes (Turret - X2, Z2) + 3 axes (Loader - X, Y, Z) + 1 axis (tail-stock Z axis)
Position sensor (X, Y, Z axes)		Absolute serial type encoder
Least input increment	X-axis	0.001 mm/P
	Z-axis	0.001 mm/P
	Loader X, Y, Z axes	0.01 mm/P
Least movement increment	X-axis	0.0005 mm/P
	Z-axis	0.001 mm/P
	Loader X, Y, Z axes	0.01 mm/P
Manual continuous feed jog		0 ~ 1386 mm/min
Manual pulse generator jog		0.001 mm/div, 0.01 mm/div, 0.1 mm/div
Overrides Rapid (Separate for both turrets)	Feedrate	0 to 110 % in 10 % steps
	Rapid traverse	0 % 25 % 50 % 100 %
	Spindle speed	50 % to 120 % in 10 % steps

MW300	MW400
ø 305 mm (12 inch)	ø 380 mm (15 inch)
—	—
10 × 2	8 × 2
15 × 2	12 × 2
250 mm 20 m/min	250 mm 20 m/min
265 mm 15 m/min	265 mm 20 m/min
□ 25 mm	□ 25 mm
ø 50 mm	ø 50 mm
18.5 kW/30min × 2	22 kW/30min × 2
22 kW/30min × 2	30 kW/30min × 2
30 kW/30min × 2	—
35 ~ 3500 rpm (18.5 kW, 22 kW only)	35 ~ 3000 rpm (22 kW only)
25 ~ 2500 rpm (18.5 kW, 22 kW only)	35 ~ 3500 rpm (30 kW only)
20 ~ 2000 rpm (18.5 kW, 30 kW only)	—
ø 120 mm	ø 160 mm
—	—
ø 73 mm	ø 73 mm
—	—
JIS A2-8	JIS A2-11
W2910 mm × D2285 mm	W2910 mm × D2400 mm
11,200 kg	13,200 kg

MSS0	MS60	MS100
ø 165 mm (6 inch)	ø 165 mm (6 inch)	ø 254 mm (10 inch)
—	ø 210 mm (8 inch)	—
8	8	10
—	12	12
130 mm 24 m/min	130 mm 24 m/min	190 mm 24 m/min
110 mm 24 m/min	145 mm 24 m/min	170 mm 24 m/min
□ 20 mm	□ 20 mm	□ 25 mm
ø 40 mm	ø 40 mm	ø 40 mm
5.5 kW/30min	7.5 kW/30min	15 kW/30min
—	11 kW/30min	22 kW/30min
—	—	—
45 ~ 4500 rpm	45 ~ 4500 rpm	24 ~ 2400 rpm
30 ~ 3000 rpm	30 ~ 3000 rpm	35 ~ 3500 rpm
60 ~ 6000 rpm	60 ~ 6000 rpm (7.5 kW only)	—
ø 80 mm	ø 90 mm	ø 100 mm
—	ø 100 mm	ø 110 mm
ø 47 mm	ø 47 mm	ø 63 mm
—	—	ø 73 mm
JIS A2-5	JIS A2-5	JIS A2-6
W980 mm × D1650 mm	W1080 mm × D1810 mm	W1320 mm × D2130 mm
2,200 kg	2,500 kg	4,000 kg

MW200 / MS100	MW300	MW400
6.0 kg × 2 (Option : 8kg × 2)	15.0 kg × 2	25.0 kg × 2
ø 200 mm × 120 mm	ø 280 mm × 160 mm	ø 350 mm × 120 mm
150 m/min	100 m/min	120 m/min
650 mm	850 mm	1070 mm
110 m/min	100 m/min	110 m/min
300 mm	300 mm	250 mm
50 m/min	20 m/min	50 m/min
180°	180°	90° (Lower side only)
0.9 sec/180° (Option : 1.5 sec)	1.5 sec/180°	1.5 sec/90°
ø 55 mm	ø 76 mm	ø 55 mm
9.0 sec (Option : 9.6 sec)	10.0 sec	12.0 sec

Turret index / Tool offset	T command (4-digit / 2+2)
Assist function	M code (3-digit)
LCD display	10.4" color, 7.2" monochrome
Auto input coding recognition	EIA RS244A, ISO 840 tape code
Tape reader/punch interface	Memory Card
Manual Data Input : MDI	Fully keyboard manual data input

ADDITIONAL CNC FEATURES (STANDARD)

- Sub-program (10 fold nesting) *1
- Sub-program (4 fold nesting) *2
- Canned cycle
- Dwell
- Machine lock
- Dry run
- Program number search
- Sequence number search
- Normal decimal point or calculator type decimal point input programming
- Exact stop mode
- Automatic work coordinate reference shift
- Direct input of measured data offset type
- Backlash compensation applied separately for cutting feed and rapid traverse
- Data protection key: 4 types
- Sub-program stop/ end (M00~M02, M30)
- Optional block skip
- Emergency stop
- Feed hold
- Single block
- Sequence number display: 8 digit *1
- Sequence number display: 5 digit *2
- Circular interpolation radius programming
- Diameter/ radius programming (X-axis)
- Work co-ordinate shift/ Work co-ordinate shift direct input
- Stored stroke limit1
- Absolute/ incremental programming method
- Linear, circular interpolation
- Feed per minute/ Feed per revolution
- Tool offset
- Extended program edit *1
- Extended part program editing *2
- Detect abnormal function
- Position switch
- Reference return with mechanical stopper setting
- Constant surface speed control
- Tool offset (Geometric/ wear)
- Polar coordinate interpolation/ Cylindrical interpolation *3
- Cs axis control function *3

*1 : Without MW300, MW400, MJ200 *2 : Only MW300, MW400, MJ200 *3 : Only MD series

Specifications

Basic Machine Specifications

		MD60	MD100	MD120	MD200
Maximum chuck size	Standard	ø 165 mm (6 inch)	ø 254 mm (10 inch)	ø 165 mm (6 inch)	ø 254 mm (10 inch)
	Option	ø 210 mm (8 inch)	—	ø 210 mm (8 inch)	—
Number of turret stations		10	10	10 × 2	10 × 2
Specification of cutting axes for turret (Stroke/Max. speed)	X-axis	125 mm 24 m/min	190 mm 20 m/min	125 mm 24 m/min	190 mm 20 m/min
	Z-axis	145 mm 24 m/min	170 mm 16 m/min	145 mm 24 m/min	170 mm 16 m/min
Use tool	O.D. tool	□ 20 mm	□ 25 mm	□ 20 mm	□ 25 mm
	I.D. tool	ø 40 mm	ø 40 mm	ø 40 mm	ø 40 mm
Spindle drive motor	Standard	7.5 kW/30min	11 kW/30min	7.5 kW/30min × 2	11 kW/30min × 2
	Option	11 kW/30min	22 kW/30min	11 kW/30min × 2	22 kW/30min × 2
Spindle speed range	Standard A	45 ~ 4500 rpm	20 ~ 2000 rpm	45 ~ 4500 rpm	20 ~ 2000 rpm
	Standard B	30 ~ 3000 rpm (7.5 kW only)	—	30 ~ 3000 rpm (7.5 kW only)	—
	Standard C	60 ~ 6000 rpm	—	60 ~ 6000 rpm	—
Spindle diameter at front bearing mounting		ø 90 mm	ø 110 mm	ø 90 mm	ø 110 mm
Diameter of spindle bore		ø 47 mm	ø 73 mm	ø 47 mm	ø 73 mm
Spindle nose size		JIS A2-5	JIS A2-6	JIS A2-5	JIS A2-6
Foot print		W1080 mm × D1810 mm	W1320 mm × D2130 mm	W1900 mm × D1810 mm	W2360 mm × D2130 mm
Total weight		2,400 kg	4,200 kg	5,000 kg	7,400 kg

Live tooling specifications

		MD60 / MD120	MD100 / MD200
Live tool drive motor		2.5 kW (8 N/continuous)	4.0 kW (22 N/continuous)
Maximum speed		4000 rpm	3000 rpm
Maximum tool shank size	Milling	ø 16 mm	ø 20 mm
	Tapping	M 10	M 16
Spindle positioning function	C-axis control	Positioning Accuracy : ± 0.015°	Positioning Accuracy : ± 0.015°
	Maximum speed	200 rpm	100 rpm
	Least command increment	0.001°	0.001°
Spindle brake	Hydraulic brake torque	126 N (12.8 kgf) [3.5 Mpa (35 kgf/cm ²)]	412 N (42 kgf) [4.0 Mpa (40 kgf/cm ²)]

Gantry loader Specifications

		MD60 / MD120	MD100 / MD200
Loader workpiece handling capacity (weight)		3.0 kg × 2	6.0 kg × 2 (Option : 8 kg × 2)
Loader workpiece handling capacity (size)		ø 120 mm × 80 mm	ø 200 mm × 120 mm
X-axis (Left/Right)	Stroke	The gantry loader X-axis stroke adjustable to layout.	
	Max. Speed	160 m/min	150 m/min
Y-axis (Up/Down)	Stroke	550 mm	650 mm
	Max. Speed	120 m/min	110 m/min
Z-axis (Front/Rear)	Stroke	205 mm	300 mm
	Max. Speed	35 m/min	50 m/min
α-axis	Stroke	180°	180°
	Cycle time	0.6 sec/180°	0.9 sec/180° (Option : 1.5 sec)
Jaw Stroke	Loader/ T/A unit	ø 30 mm	ø 55 mm
Standard loading time		7.0 sec	9.0 sec (Option : 9.6 sec)

SELECTABLE CNC OPTION

Part program storage length/
Number of registrable programs/
Number of tool offset (Geometric/ wear)

		MW50 MW100 MW120 MW200	MD120 MD200
Part program storage length	Total 64 K byte (Equivalent to 80 m × 2)	◎	◎
	Total 128 K byte (Equivalent to 160 m × 2)	○	○
	Total 256 K byte (Equivalent to 320 m × 2)	○	○
	Total 512 K byte (Equivalent to 640 m × 2)	○	○
	Total 1 M byte (Equivalent to 1280 m × 2)	○	○
Number of registrable programs	Total 63	◎	◎
	Extension 1 (depend on Part program storage length)	○	○
Number of tool offset (Geometric/ wear)	Total 32	◎	◎
	Total 64	○	○
	Total 200	○	○

		MS50 MS60 MS100	MD60 MD100	MJ60 MJ100
Part program storage length	64 K byte	◎	◎	◎
	128 K byte	○	○	○
	256 K byte	○	○	○
	512 K byte	○	○	○
	1 M byte	○	○	○
Number of registrable programs	63	◎	◎	◎
	Extension 1 (depend on Part program storage length)	○	○	○
Number of tool offset (Geometric/ wear)	32	◎	◎	◎
	64	○	○	○
	200	○	○	○

◎ : Standard ○ : Option

Basic Machine Specifications

		MJ60	MJ100	MJ200
Maximum chuck size	Standard	ø 165 mm (6 inch)	ø 254 mm (10 inch)	ø 254 mm (10 inch)
	Option	ø 210 mm (8 inch)	—	—
Number of turret stations	Standard	8	10	10 × 2
	Option	—	12	—
Specification of cutting axes for turret (Stroke/Max. speed)	X-axis	130 mm 24 m/min	190 mm 24 m/min	190 mm 24 m/min
	Z-axis	165 mm 24 m/min	170 mm 24 m/min	270 mm 24 m/min
Use tool	O.D. tool	□ 20 mm	□ 25 mm	□ 25 mm
	I.D. tool	ø 40 mm	ø 40 mm	ø 40 mm
Spindle drive motor	Standard	7.5 kW/30min	15 kW/30min	22 kW/30min
	Option	11 kW/30min	22 kW/30min	—
Spindle speed range	Standard A	45 ~ 4500 rpm	24 ~ 2400 rpm	24 ~ 2400 rpm
	Standard B	30 ~ 3000 rpm	35 ~ 3500 rpm	35 ~ 3500 rpm
	Standard C	60 ~ 6000 rpm (7.5 kW only)	—	—
Spindle diameter at front bearing mounting	Standard	ø 90 mm	ø 100 mm	ø 110 mm
	Option	—	ø 110 mm	—
Diameter of spindle bore	Standard	ø 57 mm	ø 63 mm	ø 73 mm
	Option	—	ø 73 mm	—
Spindle nose size		JIS A2-5	JIS A2-6	JIS A2-6
Foot print		W1180 mm × D1950 mm	W1715 mm × D2130 mm	W1900 mm × D2350 mm
Total weight		3,600 kg	5,400 kg	7,000 kg

Tailstock specifications

	MJ60	MJ100	MJ200
Tailstock	MT4 (Rolling center)	MT5 (Rolling center)	MT5 (Rolling center)
	Quil	Quil	Quil & Up/Down
Quil stroke	60 mm (Hydraulic drive)	230 mm (Hydraulic drive)	110 mm (Servo drive)
Quil Up/Down stroke	—	—	110 mm (Hydraulic drive)
Base-slide offset stroke	100 mm	95 mm	—

Gantry loader Specifications

		MJ60	MJ100	MJ200
Loader workpiece handling capacity (weight)		1.0 kg × 2	2.5 kg × 2	2.5 kg × 2
Loader workpiece handling capacity (size)		ø 40 mm × 145 mm	ø 100 mm × 250 mm	ø 100 mm × 250 mm
X-axis (Left/Right)	Stroke	The gantry loader X-axis stroke adjustable to layout.		
	Max. Speed	150 m/min	150 m/min	150 m/min
Y-axis (Up/Down)	Stroke	502 mm	650 mm	550 mm
	Max. Speed	110 m/min	110 m/min	110 m/min
Z-axis (Front/Rear)	Stroke	155 mm	150 m/min	300 mm
	Max. Speed	35 m/min	50 m/min	50 m/min
α-axis	Stroke	90°	180°	90°
	Cycle time	0.7 sec/90°	0.9 sec/180°	1.0 sec/90°
Jaw Stroke	Loader/ T/A unit	ø 30 mm	ø 55 mm	ø 40 mm
Standard loading time		9.0 sec	9.0 sec	10.0 sec

	MW300 MW400	MJ200
--	----------------	-------

	MW300 MW400	MJ200	
Memory size	40 m × 2	◎	◎
	80 m (30 K byte) × 2	○	○
	160 m (60 K byte) × 2	○	○
	320 m (120 K byte) × 2	○	○
	640 m (240 K byte) × 2	○	○
	1280 m (490 K byte) × 2	○	○
Number of registrable programs	63 × 2	◎	◎
	125 × 2	○	○
	200 × 2	○	○
	400 × 2	○	○
Number of tool offset (Geometric/ wear)	16 × 2	◎	◎
	32 × 2	○	○
	64 × 2	○	○

CNC FEATURES (OPTION)

- Least input increment : sub-micrometer
- Inch/Metric conversion
- Thread cutting cycle retract
- Variable lead threading
- Continuous threading
- Stored pitch error compensation
- workpiece coordinate system
- Direct drawing dimension programming
- Tool nose R compensation
- Chamfering/ Corner R
- Multiple repetitive programming □
- Multiple repetitive programming
- Canned cycle for drilling
- Custom macro
- Custom macro common variables
- Direct input of tool offset value measured B
- Rigid tap function
- Spindle orientation
- Display of run time and Parts preset
- Background edit function
- Graphic function

MW50 Standard Cell system

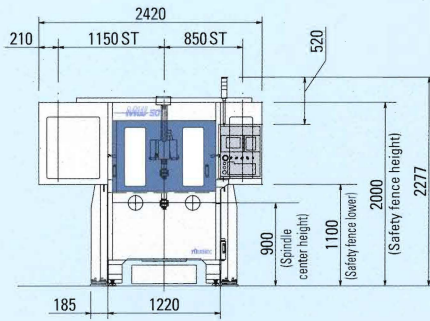
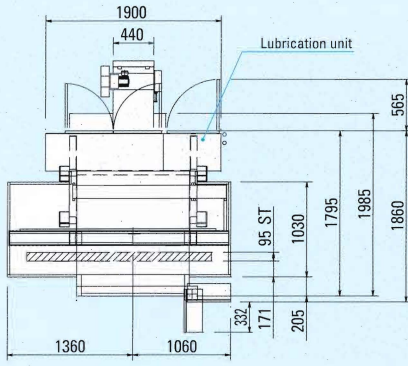

(Unit: mm)

MW120 Standard Cell system

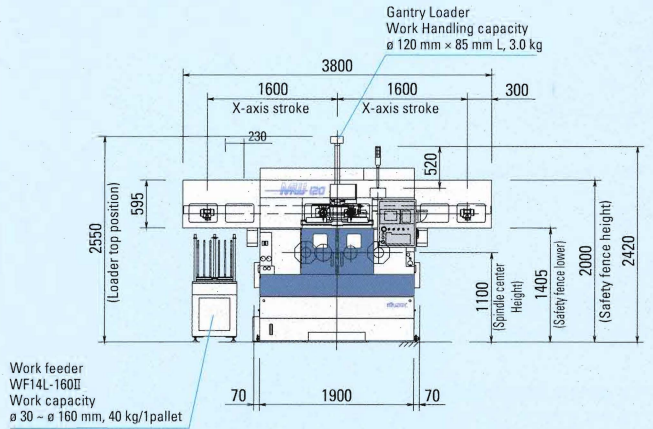
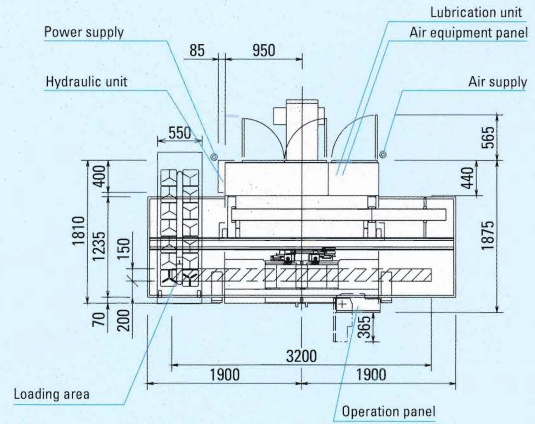

Work feeder
WF14L-160II
Work capacity
 $\phi 30 - \phi 160 \text{ mm}$, 40 kg/pallet

(Unit: mm)

MW100 Standard Cell system

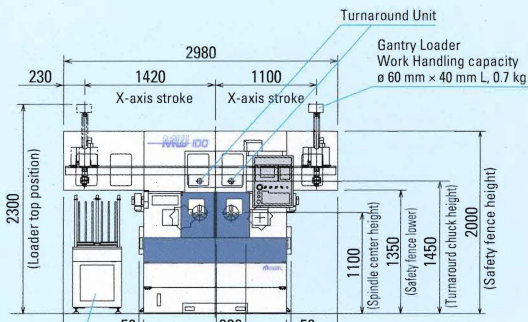
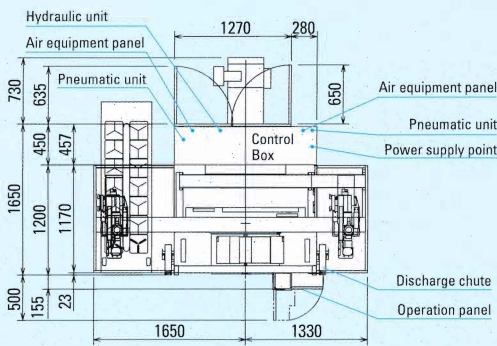

Palet feeder
WF14L-160II
Work capacity
 $\phi 30 - \phi 160 \text{ mm}$, 50 kg/pallet

(Unit: mm)

MW200 Standard Cell system

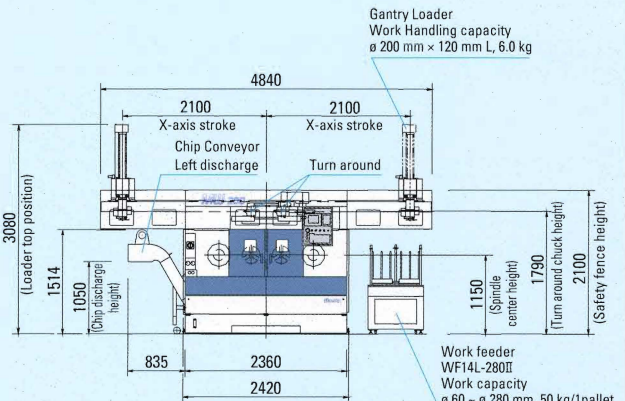
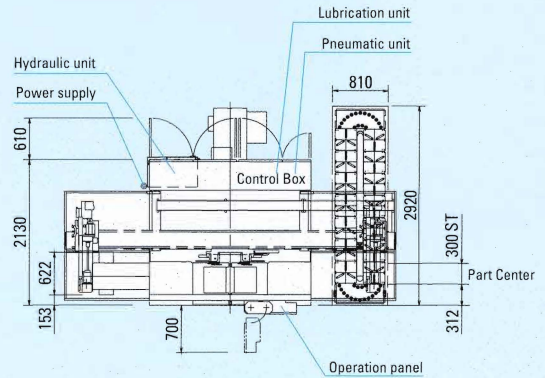

Work feeder
WF14L-280II
Work capacity
 $\phi 60 - \phi 280 \text{ mm}$, 50 kg/pallet

(Unit: mm)

MW300 Standard Cell system

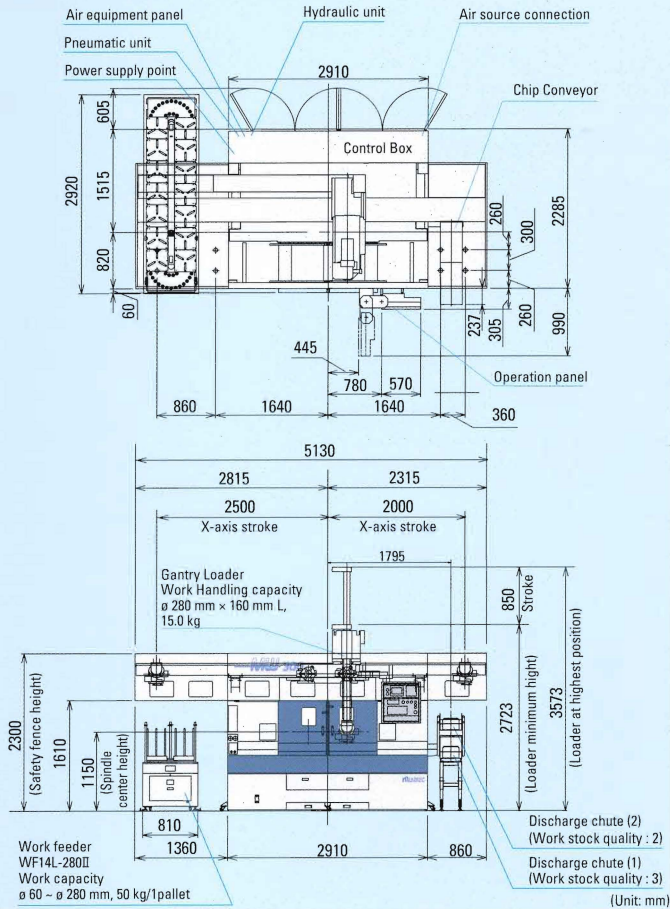

MS50 Standard Cell system

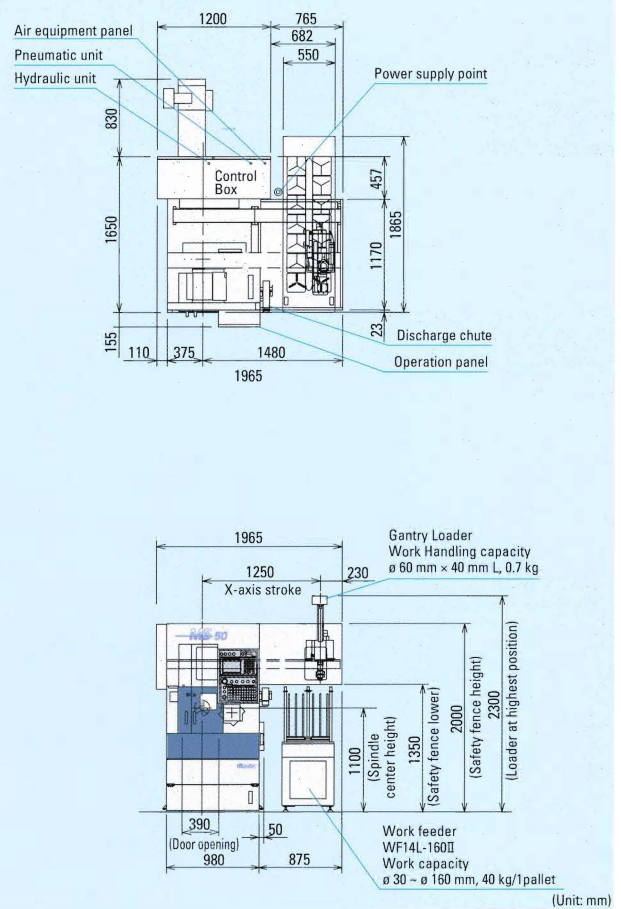

MW400 Standard Cell system

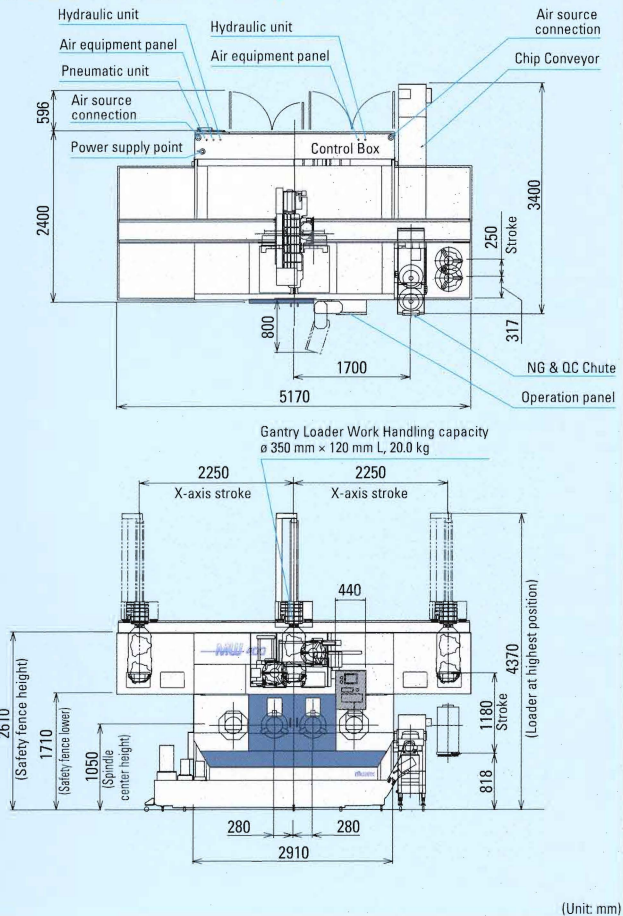

MS60 Standard Cell system

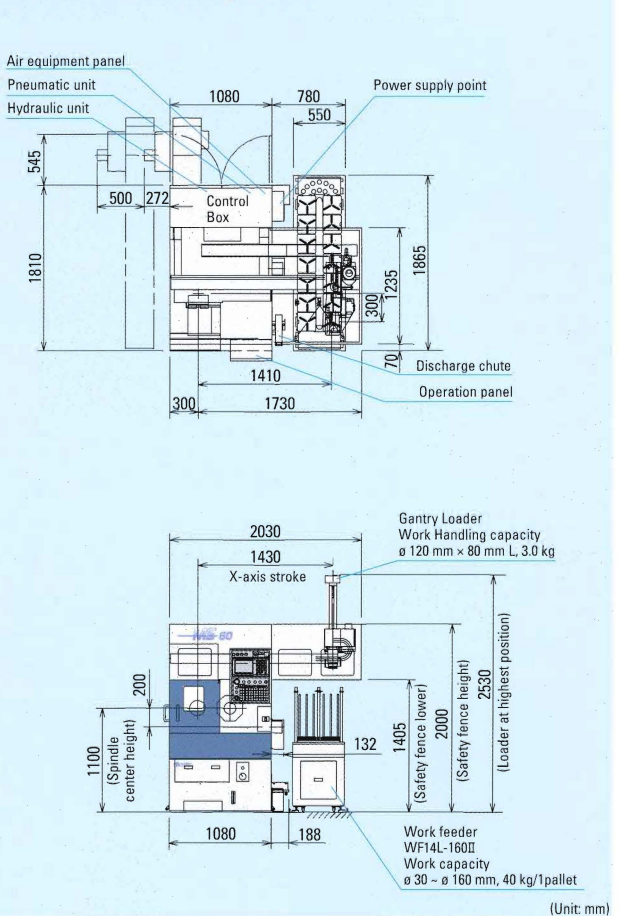

MS100 Standard Cell system

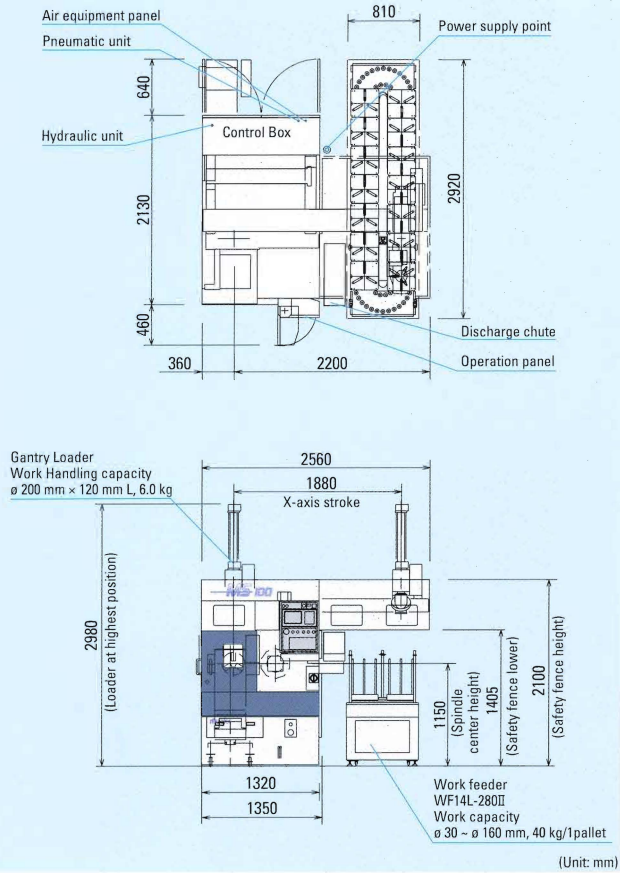

MD100 Standard Cell system

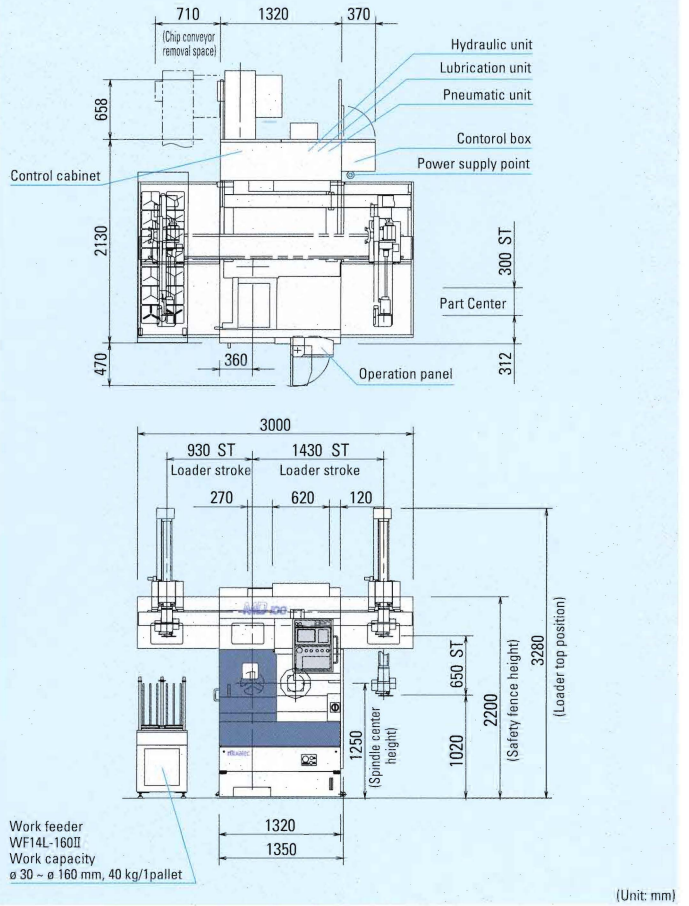

MD60 Standard Cell system

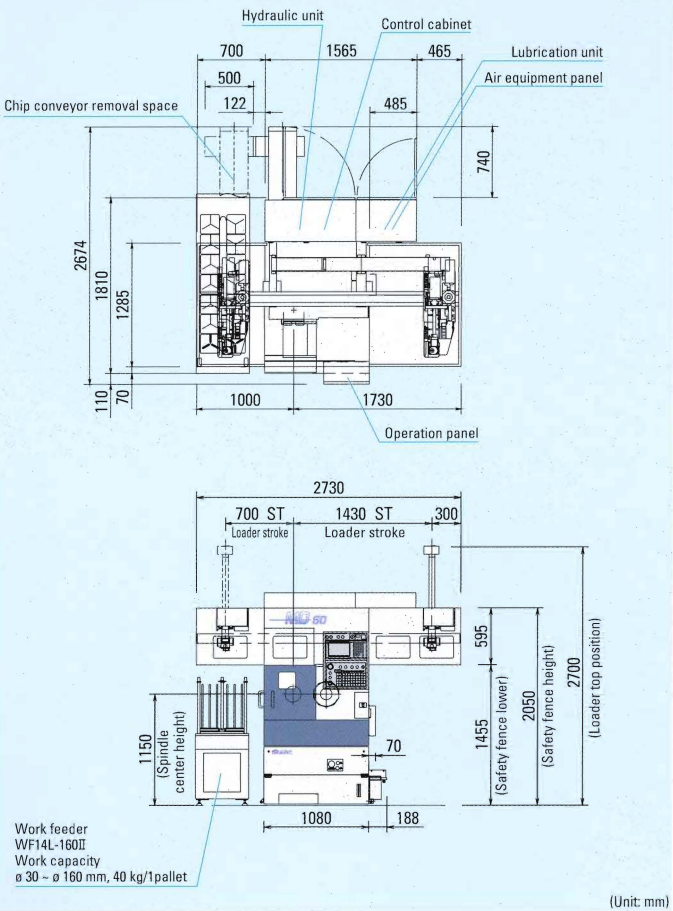

MD120 Standard Cell system

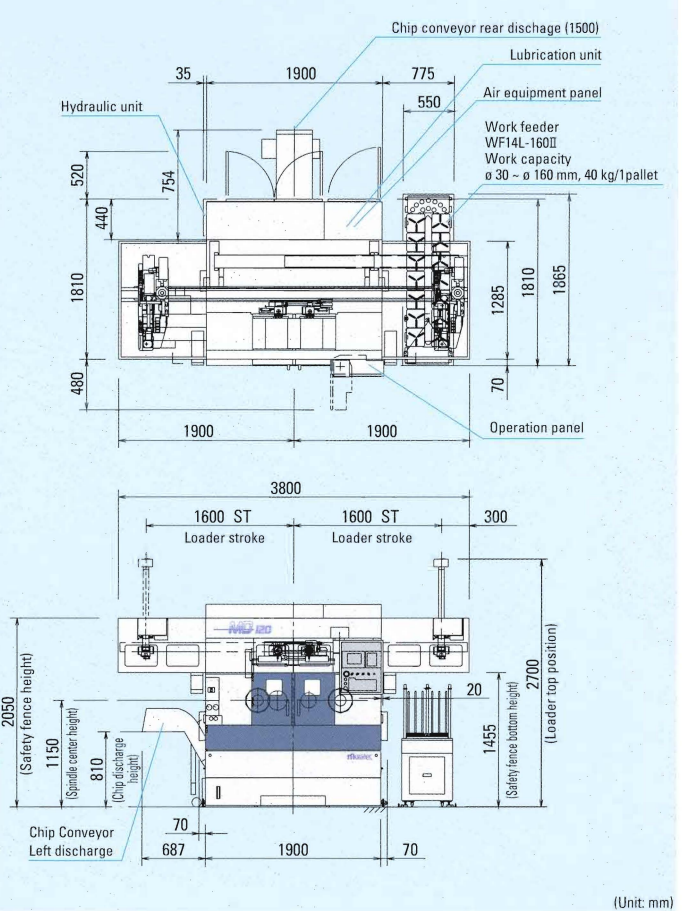

MD200 Standard Cell system

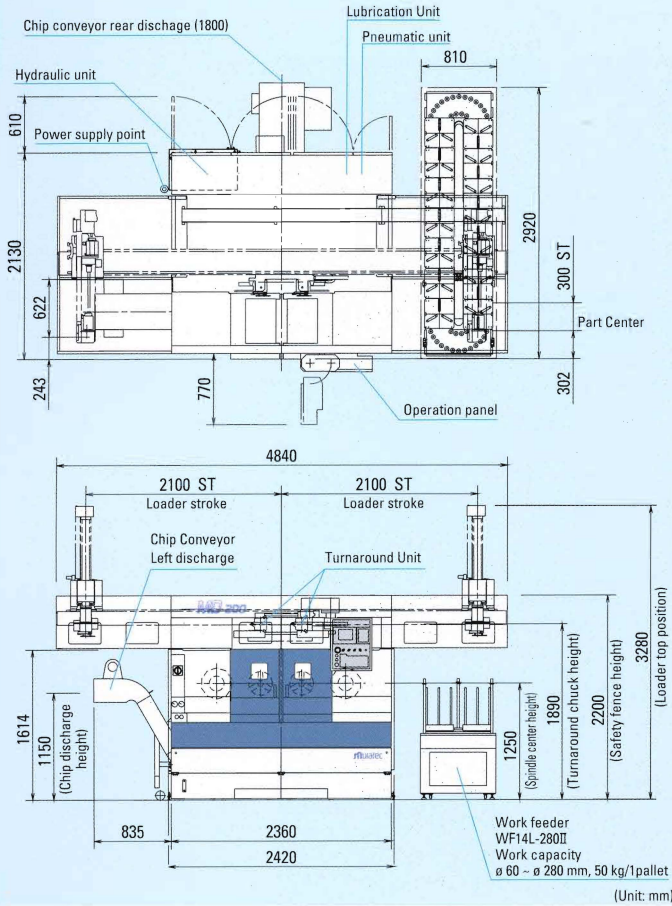

MJ100 Standard Cell system

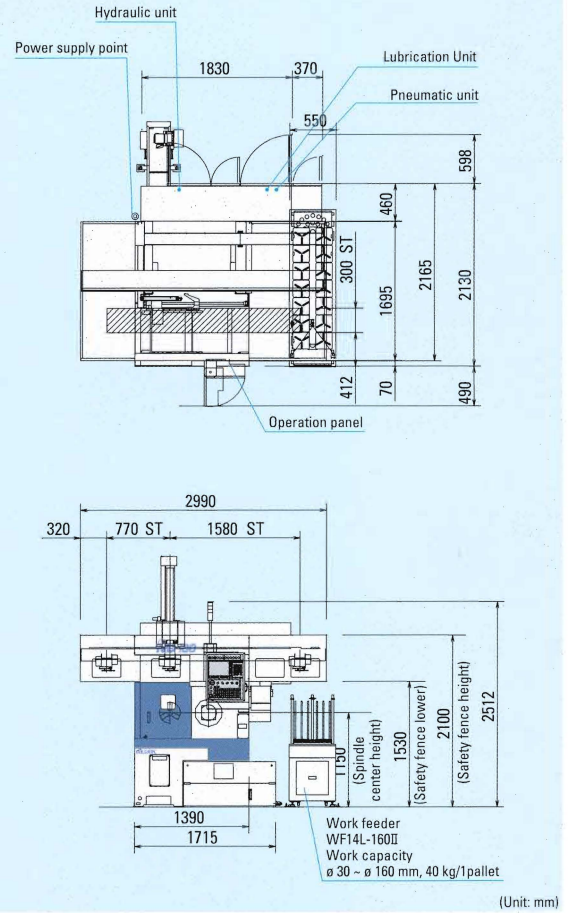

MJ60 Standard Cell system

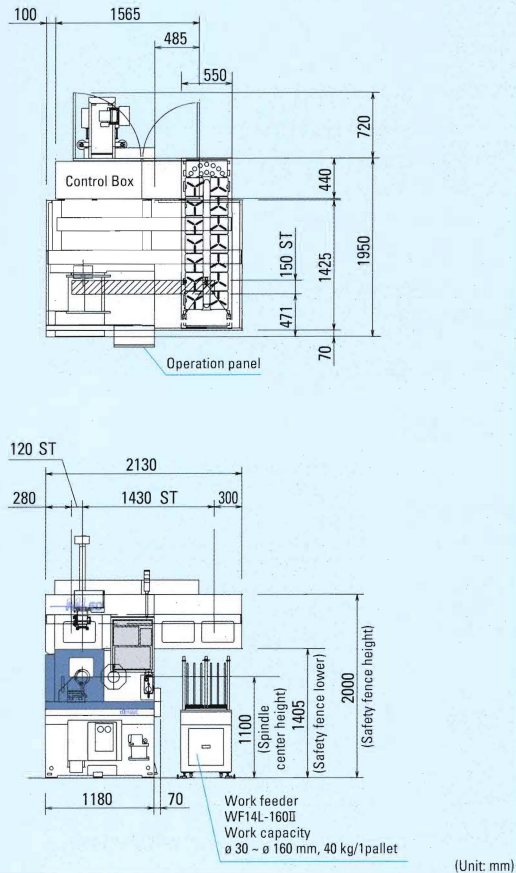

MJ200 Standard Cell system

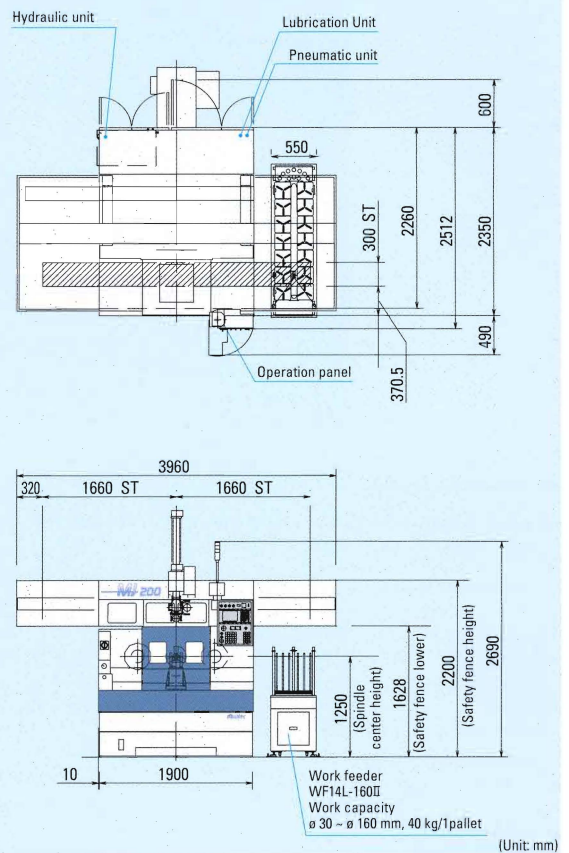

■ Safety Specification

For EU countries, machines are built with CE-safety conformity.

* Machine appearance may differ to that shown in the catalogue pictures.

* All specifications are subject to change without advance notice.

MURATA MACHINERY, LTD.
MACHINE TOOLS DIVISION

International Business Dept.

2, Nakajima, Hashizume, Inuyama-shi, AICHI 484-8502, JAPAN
TEL : +81-(0)568-61-3645 FAX : +81-(0)568-61-6455

Headquarters

136, Takeda-Mukaishiro-cho, Fushimi-ku, KYOTO 612-8686,
JAPAN

TEL : +81-(0)75-672-8138 FAX : +81-(0)75-672-8691

<http://www.muratec.co.jp>

e-mail info@muratec.co.jp

MURATA MACHINERY USA, INC

2120 Queen City Drive, P.O.Box 667609,
Charlotte, N.C. 28208, U.S.A.

TEL : +1-704-875-9280 FAX : +1-704-392-6541

<http://www.muratec-usa.com>

MURATA MACHINERY EUROPE GmbH

Hanns-Martin-Schleyer-Straße 3, D-47877, Willich, GERMANY

TEL : +49-(0)2154-914-250 FAX : +49-(0)2154-914-283

**MURATA DO BRASIL COMERCIO
E REPRESENTACAO DE MAQUINAS LTDA.**

Estrada de Santa Izabel, 3383-KM 38,5

Itaquaquecetuba-SP-CEP 08599-000 BRAZIL

TEL : +55-(0)11-4648-6222 FAX : +55-(0)11-4648-6737

MURATA MACHINERY (SHANGHAI) CO.,LTD

[Registry Add]

135 Fu Te Xi Yi Rd., Wai Gao Qiao Free Trade Zone,
Pudong, Shanghai, CHINA

[Contact Add]

150 Xin Gao Rd., Qingpu Industrial Zone,
Shanghai, 201700, CHINA

TEL:+86-(0)21-6921-2300 FAX:+86-(0)21-6921-2330

