

Dominations D26 SC White Paper

By : WahyuTanuwidjaja

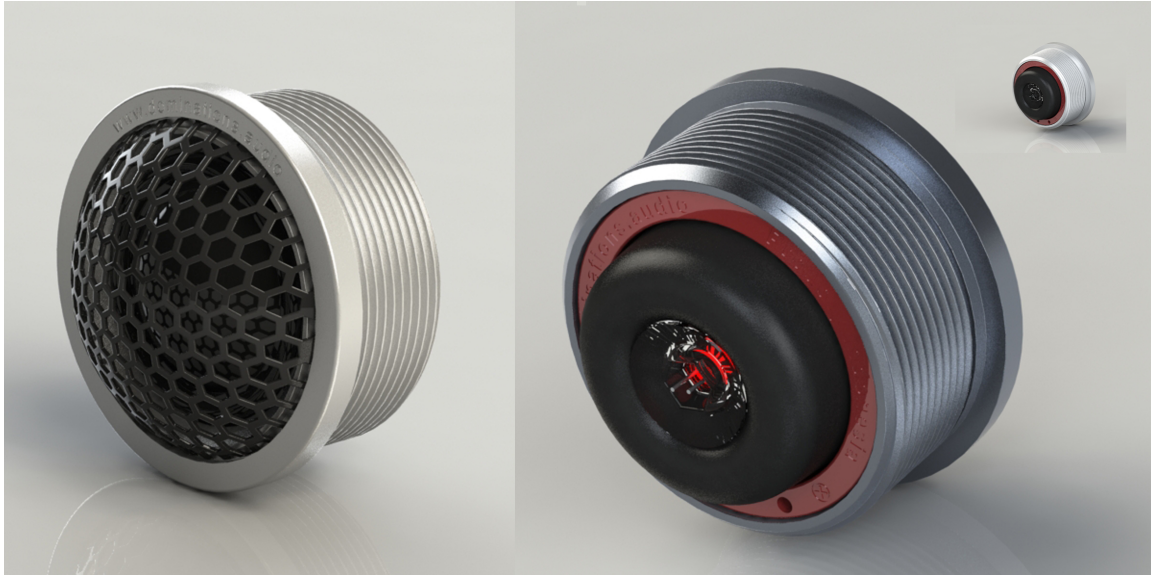

1. The General Review and The Ultimate Goal

A journey of a tweeter in the world of car audio

Observing the car audio industry development, especially for a tweeter, there are several points that my concern,

1.1. It is a fact that, the loudspeakers (speakers) that we use in the car is the 'incarnation' of a speaker system at home audio. Especially, the tweeter design parameters and the crossing point at the crossover circuit.

Set speaker system that we use at home, usually consist of (at least) a high tone speakers (tweeter) and a speaker for the underlying frequency (usually referred to as a woofer or mid-woofer).

This configuration is known as a 2 way system,

I call it a 'Configuration 2 way speaker for home'.

Characteristic point on the "2 way speaker system for home audio":

In this system,
usually tweeter will work ranging from 2500 Hz upwards,
with a tweeter resonant frequency (F_s) above 1000Hz up to 2500 Hz.

With a mid woofer work below these frequencies.

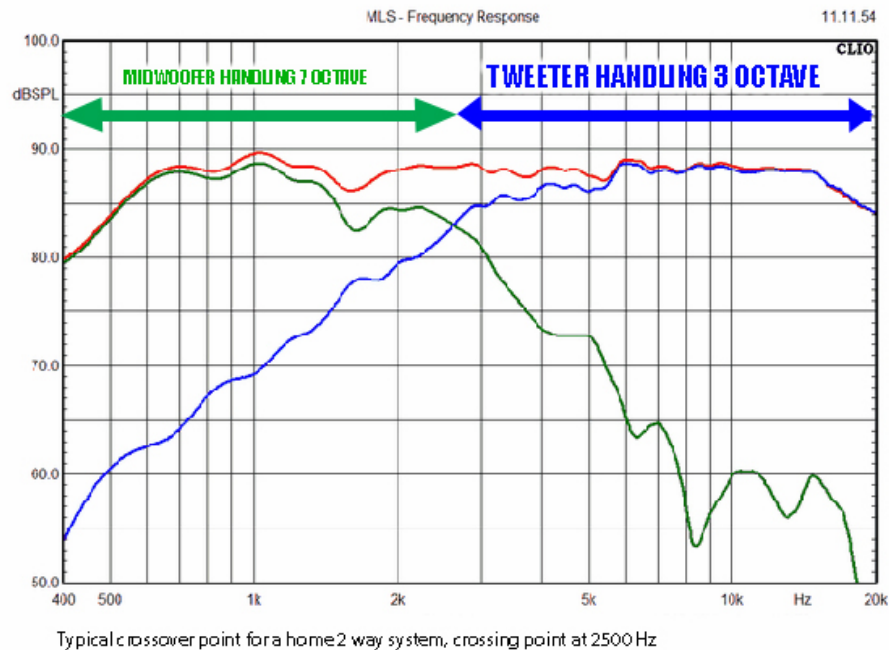

The goal is,

Creating a new tweeter, that are specially designed for car audio use. With a lower resonant frequency, but still maintain the size as an ordinary car audio tweeter.

I want tweeter that can be cut in the range of 1250Hz with a slope of 12dB slope per octave.

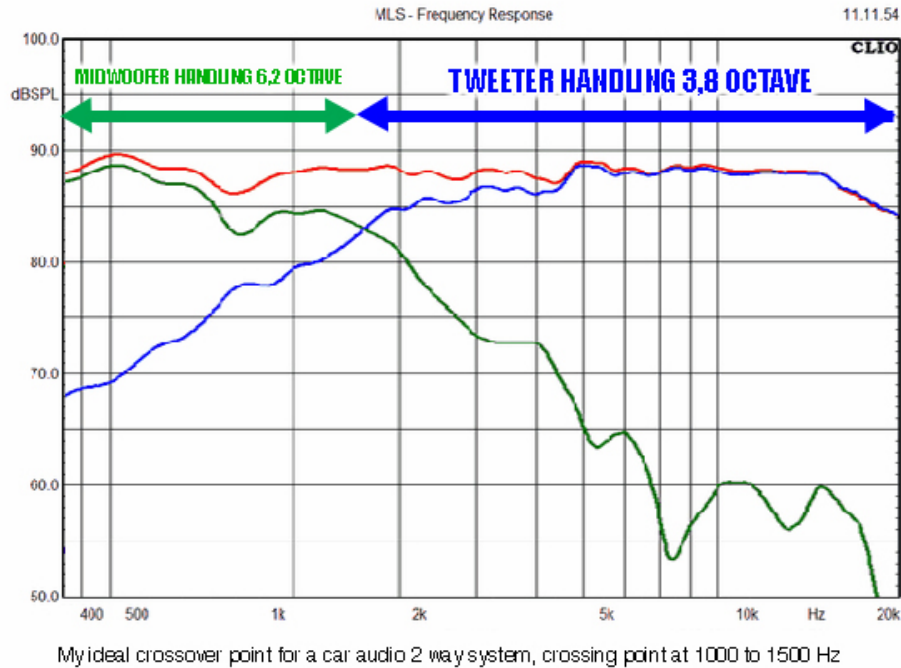

1.2. The lack of design flexibility,

A tweeter that could produce a great high notes, tend to be not so good in the lower frequencies. And the tweeter that is good at lower frequencies, usually perform not so good in high notes.

Both of the above circumstances, is not a design fault, but rather on the limitations of the priority selection of a designer.

Designer need to choose,

- A. tweeter with a good lower harmonics but it has a slight roll-off at the high notes (which is good for 2 way system), or
- B. a good high notes tweeter with a little bit 'stiff' in lower harmonics (which is good for 3 way system).

The goal is,

I want to create a new tweeter, which can function properly in two conditions, for 2 Way and 3way in the car.

The final goal can be achieved only with simple process,
not by providing two different types of tweeters.

Advantages for the installer, no need to stock the
different kind of tweeter for a different purposes.
Stock fewer means efficiency in the stock and financial.

The advantage for car audio hobbyist,
no need to replace the tweeter when you want to change
from 2 way to a 3 way system.

- 1.3. I'm bored with a typical car audio tweeter design,
I want something different.

The goal is,

Produce a product that not only works well,
but also look good and be a trend in the future.

D26SC equipped with a clear plastic bolt and can be inserted by a small
LED!

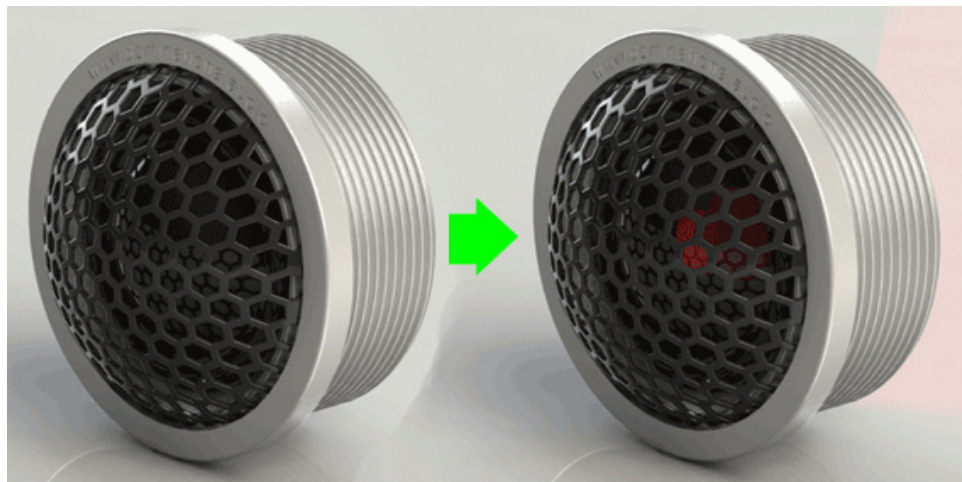

- 1.4. Flexibility of installation and when in use, which allows installers to
installed it and tune it easily.

The goal is,

Simplify the installation process, while maintaining the safety, and look attractive, can be used for 2way or 3 way.

Installation is easy and fast!

For this,

I'll open a few ideas that we design, it will be patented on a different items.

- 1.5. Maintaining the motto of Dominations,
Affordable Excellent Sound

Maintaining a rational price, although we invest so many new tooling for this project.

2. Review from physical installation differences, which led to

"a home audio tweeter **are not** suitable for car audio".

Next,

let's review the placement difference between a 2 way speaker home versus a 2 way car speakers.

- 2.1. Characteristics of speaker placement in a 2 way speaker system at home audio.

Typically, the tweeter will be adjacent to mid-woofer, tweeters can be installed below or above mid-woofer, a starting point of the sound between the two speakers will differ slightly, roughly below 0.15 mS (less than 4,5cm).

With the installation of speakers facing 'On-Axis' to the listener.

Typical 2 way home speaker

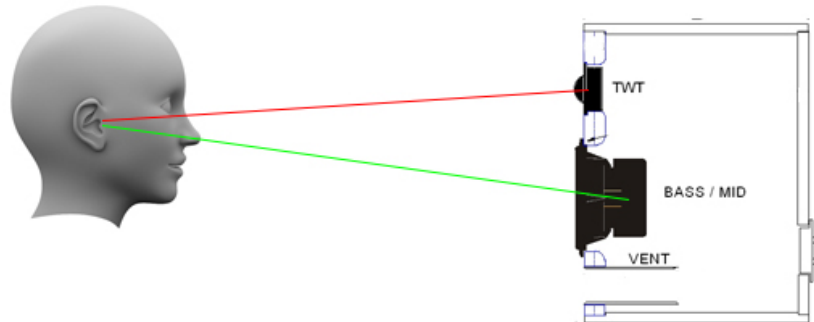

Distance between tweeter and midwoofer is below 0,15 mS
All drivers (speakers) are On Axis to the listeners and installed near to each other

- 2.2. Characteristics of speaker placement in a 2 way speaker system in a car, especially for cars with the driver on the right side, the tweeter will be around triangular area behind the left and right side mirror, or at the middle to bottom area of the A-pillar, or on the surface of the dashboard.



Tweeter at dashboard flush-mounted

Tweeter at A-pillar flush-mounted

Tweeter at side mirror triangular plastic cover

Tweeter at dashboard

Midbass will be mount at the bottom of the door trim door.

The distance between the two loudspeakers (usually) above 0,15 mS until 0,3 mS, on certain cars can be up 0,9 mS.

With mounting position of the loudspeakers tends to be Off-Axis to the listener.

Typical 2 way
car speaker

Distance between
tweeter and
midwoofer is around
0,15mS to 0,3mS

All drivers
are Off Axis to the
listeners and
installed far to each
other

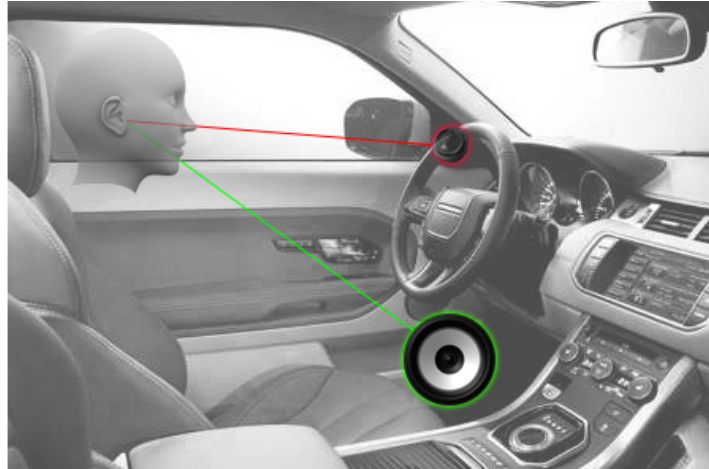

3. The problems that exist because of that situation

Speaker placement differences impact on the performance of the speaker

Both kinds of installation above is very different, and of course, an approach to the use of home loudspeaker crossover point will not be maximized for car audio.

Other than that,

3.1. The uncertainty of the frequency response from the speaker installed inside the door trim. The more bandwidth of frequency this speaker play, the more irregular curve will be produce.

3.1.1. As well as how we install the speaker (that is placed) inside the door trim, there still will be some irregularities because of,

3.1.1.1. Reflection.

3.1.1.2. Effects of space between the speakers to the door trim.

3.1.2. The time came that differ between the speakers in the door trim on the dashboard.

3.1. The greater 'portion' of the speaker inside the door trim played music (the more octave played), the greater the uncertainty that occurs.

Referring to the use of a combination of home speakers (tweeter and mid-woofer with a crossover point at 2500 Hz), then,

- 3.1.1. Tweeter will work as much 3oktaf.
- 3.1.2. Mid-bass will work as much 7oktaf.

The main cause of this situation is the 'inability' tweeter to produce lower notes.

The conclusion of the matter is:

how to 'narrow' the frequency response bandwidth for the speakers that installed inside the door trim. And add another driver somewhere in near the A-pillar/triangular/dashboard corner, which have the ability to play more on the lower notes.

This is where the concept of the speakers were really made for car.

- A. Where mid woofer only play up to 315 Hz range (below 315hz human hearing tends to be omni-directional, so that the problems of reflection in the door and the uncertainty of the response can become less problem in global, and
- B. Use another speaker installed in A-pillar /triangular /dashboard corner, known as 'full-range' which can cover 315 Hz up to 20kHz.

3.2. Answering these problems,

Since 2010,

Dominations is the first brand to implement and popularized the system called 2-way full-range in car audio, Dominations replace tweeter into a 50mm diameter speakers, with a working range from 250 Hz up to 20kHz.

This system is very successful in the market, as evidenced by there are so many other products copied this concepts.

In this system,

Full range speaker will play the music as much as 6.25 octaves and mid woofer only concentration to produce bass and mid bass in 3.75 octaves at the lower side.

In fact we can replace mid-woofer to be a woofer.

However,

this system has shortcomings, namely the size problems.

This system need a box which requires air-volume box around 250 ml, which certainly makes the system looks bulky and big.

Dominations F51 with 260 mL aluminum box, can play music from 250Hz up to 20kHz

For some listeners they dont like 'bulky' things on their eye level



Seeing this situation,

We opened our previous research, such as Futura F28 and D28 Evolution. Where both of these products can reach lower frequency (certainly not as low as the speaker with a diameter of 50mm).

We want lower notes but still retaining the physical form that is not too big (the previous project is still too large compare to the D26SC project).

DOMINATIONS[®]
AFFORDABLE EXCELLENCE SOUND

CFS SYSTEM
Creative Fidelity System

2 Way Component with **"3 Ways Performance"**

EMMA Indonesia
Master Unlimited
- **Champion** -
Master USD 56000
- **Champion** -
Experience USD 3000
- **Champion** -
Heat 2 - 2010

EMMA Singapore
Experience 3 channel
- **1st Runner Up** -
Heat 1 - 2010

EMMA Malaysia
Master 5 Channel Sound Only
- **Champion** -
Experience 3 channel
- **2nd Runner Up** -
Heat 1 - 2010

4. Introducing D26SC Tweeter that design for car audio use.

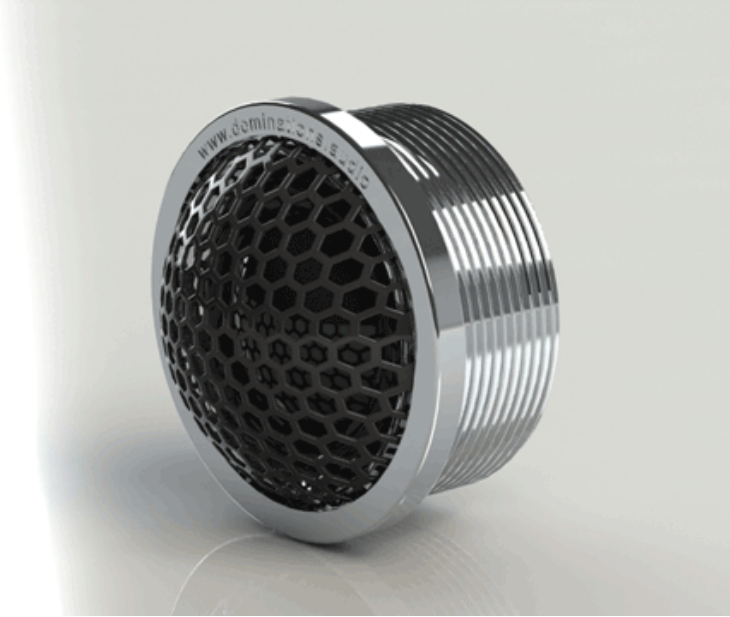

Several feature,

- 4.1. Size that is not so big and not to small, just a little bigger than ordinary car tweeter.

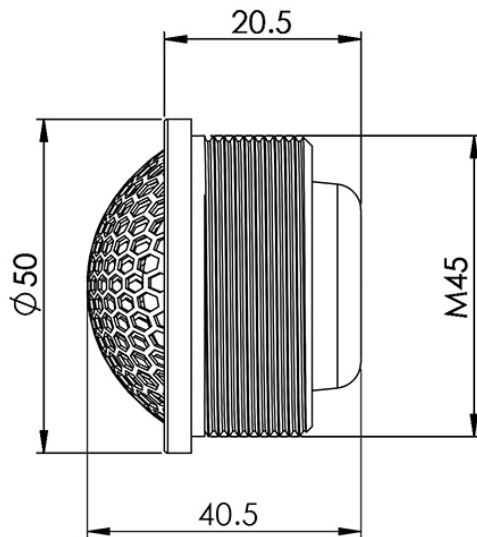

- 4.2. We been thinking an easy way to installed this tweeter. This mounting item will be on the market end of December 2016.

And can be use for tweeter, fullrange, midrange, and its combinations.



4.3. Upgradeable to 3 way system without having to replace the tweeter.

Using a bolt which serves to close and open the chamber behind.
This feature causes D26SC can be set to perform as 2-way tweeter (need lower harmonic), or 3-way tweeter (more on high frequencies).

D26SC

When the tweeter using a long Hex-Nut.
Back chamber is 'close'.

The frequency response shown a 'stiff',
less lower harmonics, but more on high frequency.
This configuration is for a three way car audio system.

When the tweeter using a long Hex-Nut.
Back chamber is 'close'.

The frequency response shown a 'stiff',
less lower harmonics, but more on high frequency.
This configuration is for a three way car audio system.



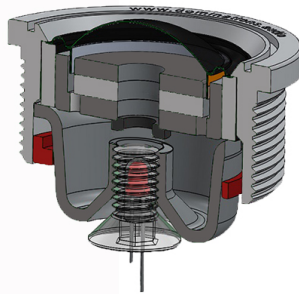

When the tweeter using a short Hex-Nut.
Back chamber is 'open'.

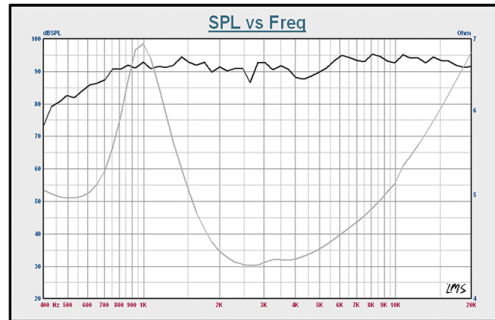

The frequency response shown a 'rich' lower harmonics.
This configuration is for two way car audio system.

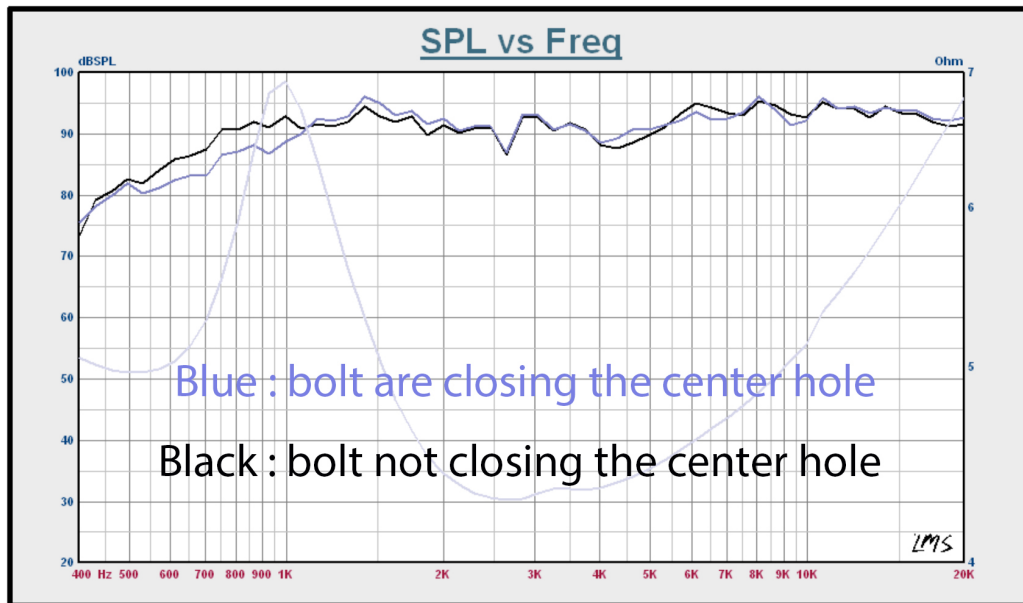

Explanation of the picture above,

At the top picture is seen that when the back chamber is used, then start from 750Hz, the pressure level already touched a 90 dB / w / m, this made this tweeter a good tweeter in 2 way system.

Unfortunately, the good performance on the lower tone makes the curve not as smooth as when the chamber is closed (4,5kHz is 3 db more, 6kHz 3 db less and 20kHz better 2dB).

Meanwhile, when the bolts are 'installed' closing the chamber, the bottom curve of the tweeter response become more 'stiff' , but it makes the tweeter to be more agile and more control.

The graph above is as it is, I do not polished or photo-shop it to make it look more flat.

- 4.4. Good appearance and performance with rational price
169 USD - 217 USD.

Have the possibility to look like a car racing wheel, can be combined in three colors. And it is equipped with a lighting system that has never been used by other manufacturers. I believe one day this idea will be imitated other manufacturers.

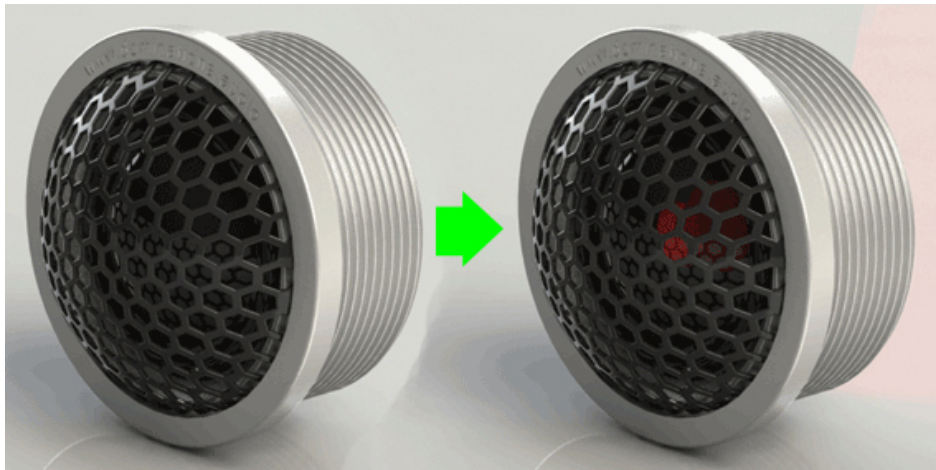

Being a trendsetter for future car tweeter.

- 4.4.1. Controlled chambered tweeter.
- 4.4.2. LED lighting.
- 4.4.3. Easy mounting.

- 4.5. Made from the best material,

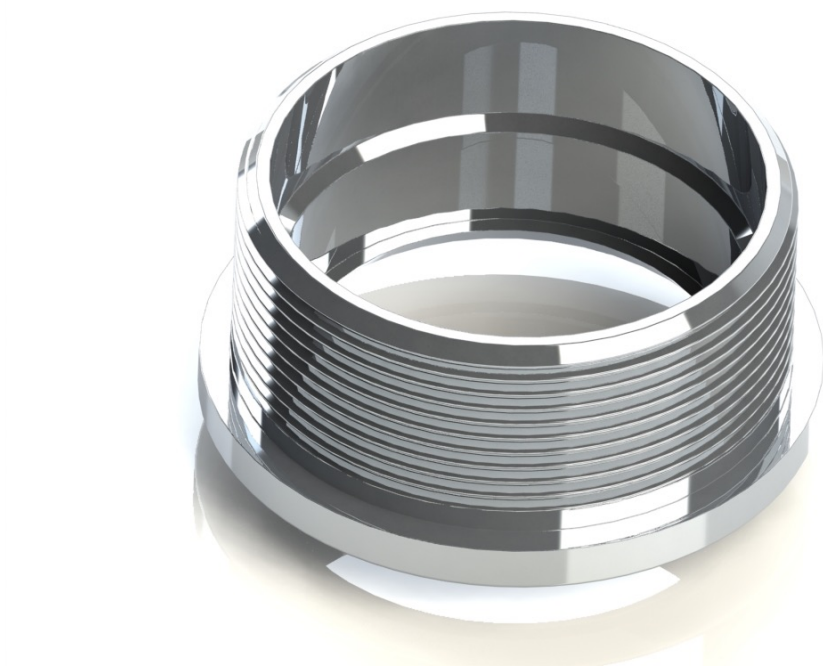
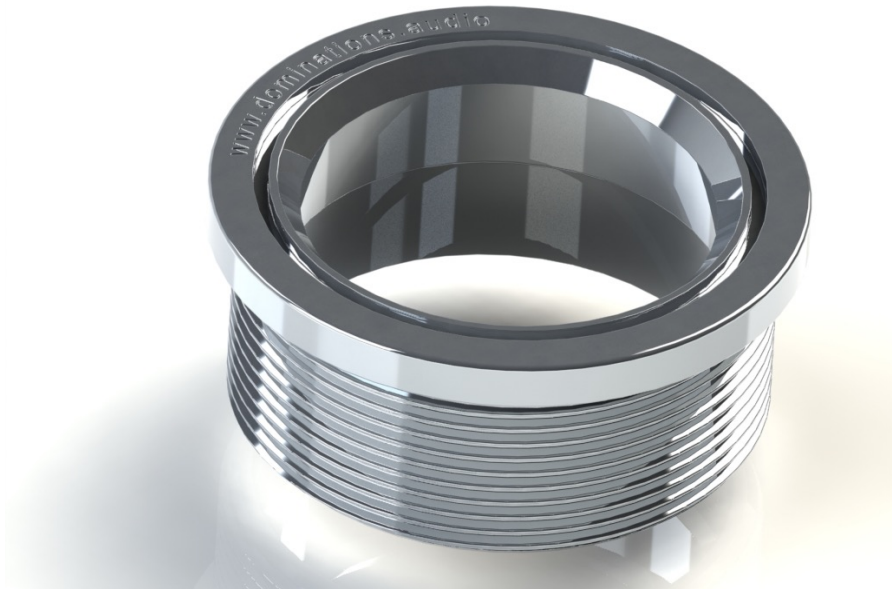

Aluminum housing, made from space grade aluminum.

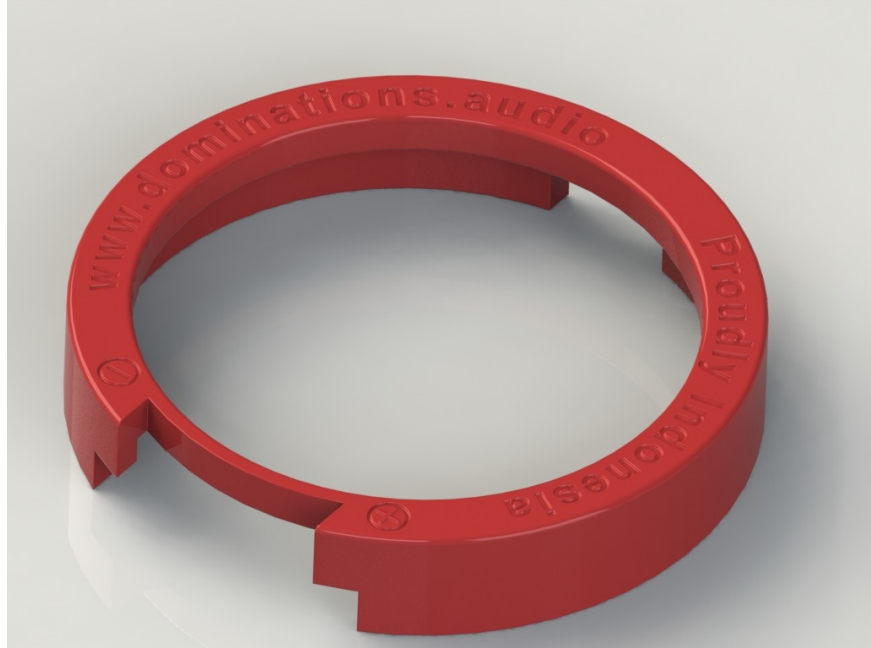

Plastic ring to reduce unit resonance, and as always proudly Indonesia.

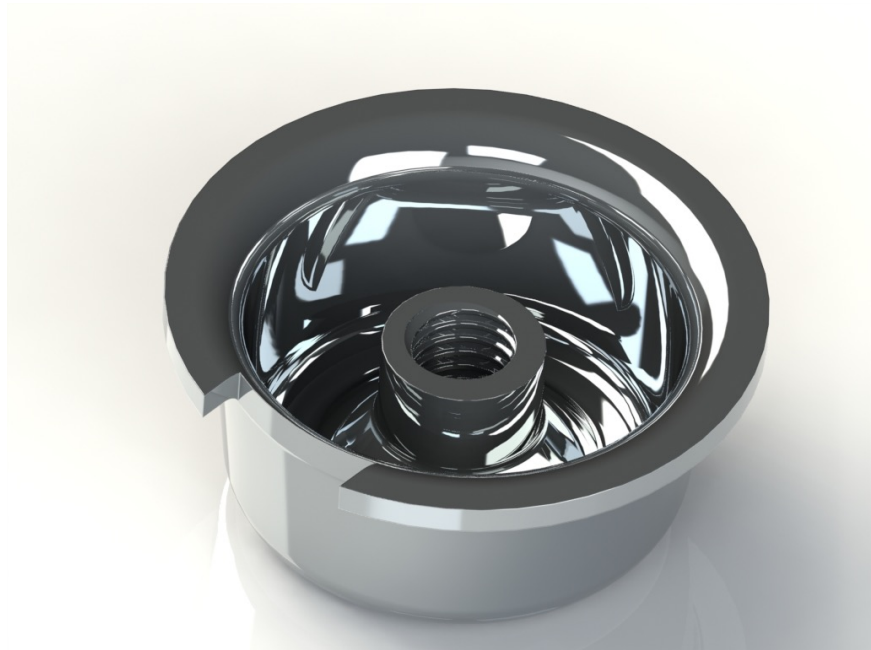



Aluminum 'curved' back chamber.

D26CC normal editions,

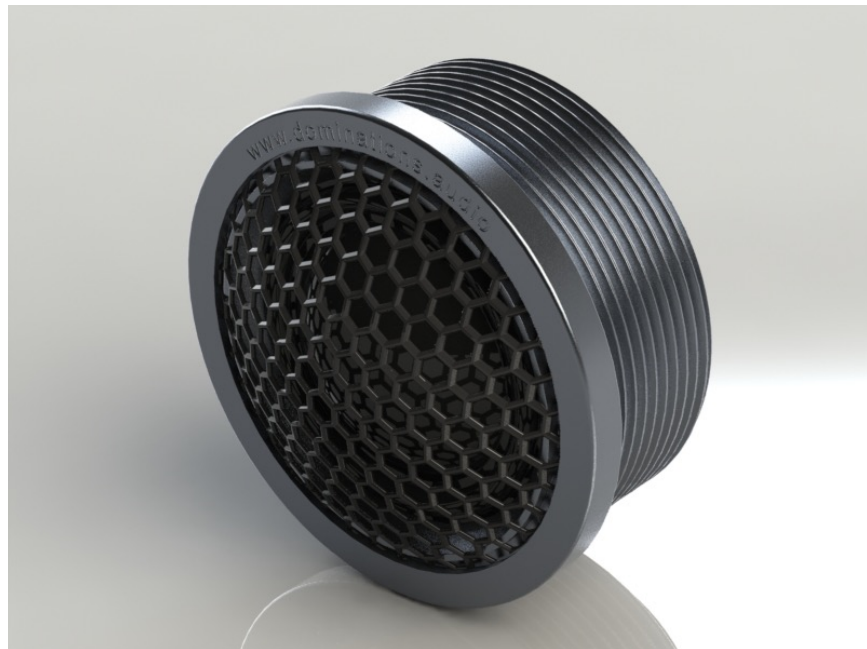

D26SC Front look, low profile frosted aluminum frame.

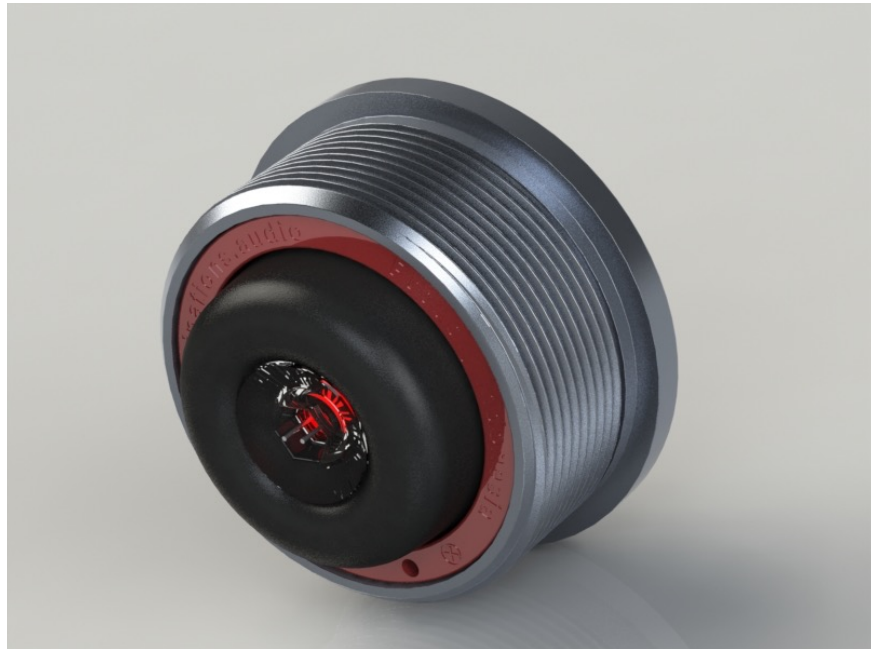

D26SC Back chamber with acrylic screw and red led lighting.

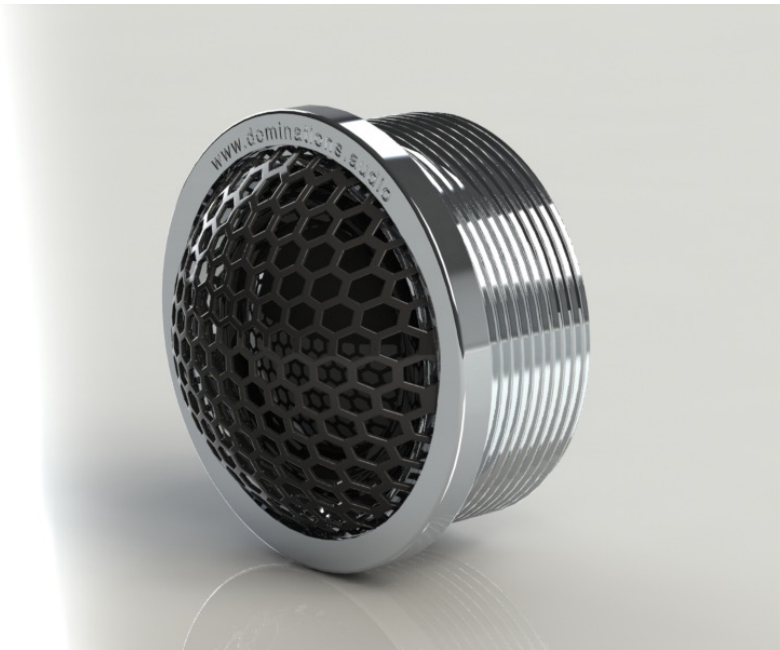

D26SC Limited Edition, match paired, 100 unit for every 1000 unit productions. Front.

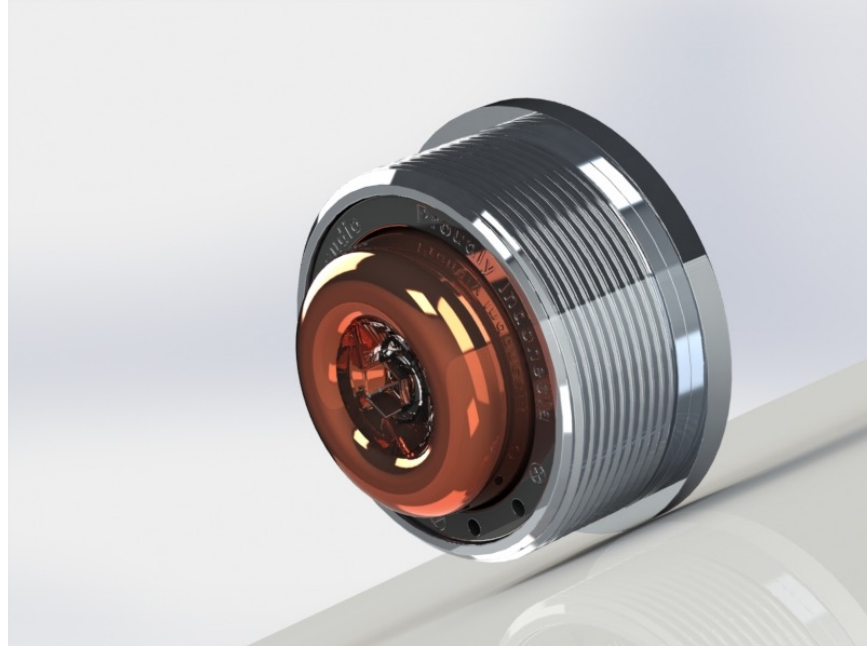

D26SC Limited Edition, back chamber. Blue lighting, chrome basket with rose gold chamber.

5. The team behind D26SC

- | | | |
|------|---|---|
| 5.1. | Ideas and Design | Mr. Wahyu Tanuwidjaja
whytan@dominationsound.com |
| 5.2. | Transducer Engineering | Mr. Steven
Audio Plus, Taiwan. |
| 5.3. | Product 3D and Imaging
www.sunjaya.xyz | Mr. Sunjaya Theja
sunjayathe@gmail.com |
| 5.4. | Head of Project Finance | Mrs. Djuhaeni
djuhaenihenny@yahoo.co.id |
| 5.5. | Artistic & Graphic Design | Mr. Ilyasa Abdillah
ailyasa@ymail.com |
| 5.6. | Testing & Evaluation | Mr. Cong Susanto
www.bestbuddyshop.com |
| 5.7. | Legal Officer | Mr Rudy Parwana
rudy.parwana@gmail.com |

- 5.8. Public Relation Officer Ms. Novia Hadiputri
noviahadiputri@yahoo.co.id
- 5.9. Webmaster Mr. Sean Tanuwidjaja
seantanuwidjaja@gmail.com
- 5.10. International Sales Mr. Chandra Budiman
+6282182777788 gabbie.budiman@gmail.com
- 5.11. Domestic sales (Ind) Ms. Cindy Theresia
+62 21 65309074 cindytheresia22@gmail.com
- Mr. Hikmat Imansyah
hikmatsatria@yahoo.com
- Mr. Alung Jarun
alungjarun@gmail.com

www.audioworkshop.co.id

PT. Audioworkshop
JL. Metro Indah Raya Blok A3 No.12a-14
Jakarta - Utara 14340
Indonesia