

Norfolk Greenhouses

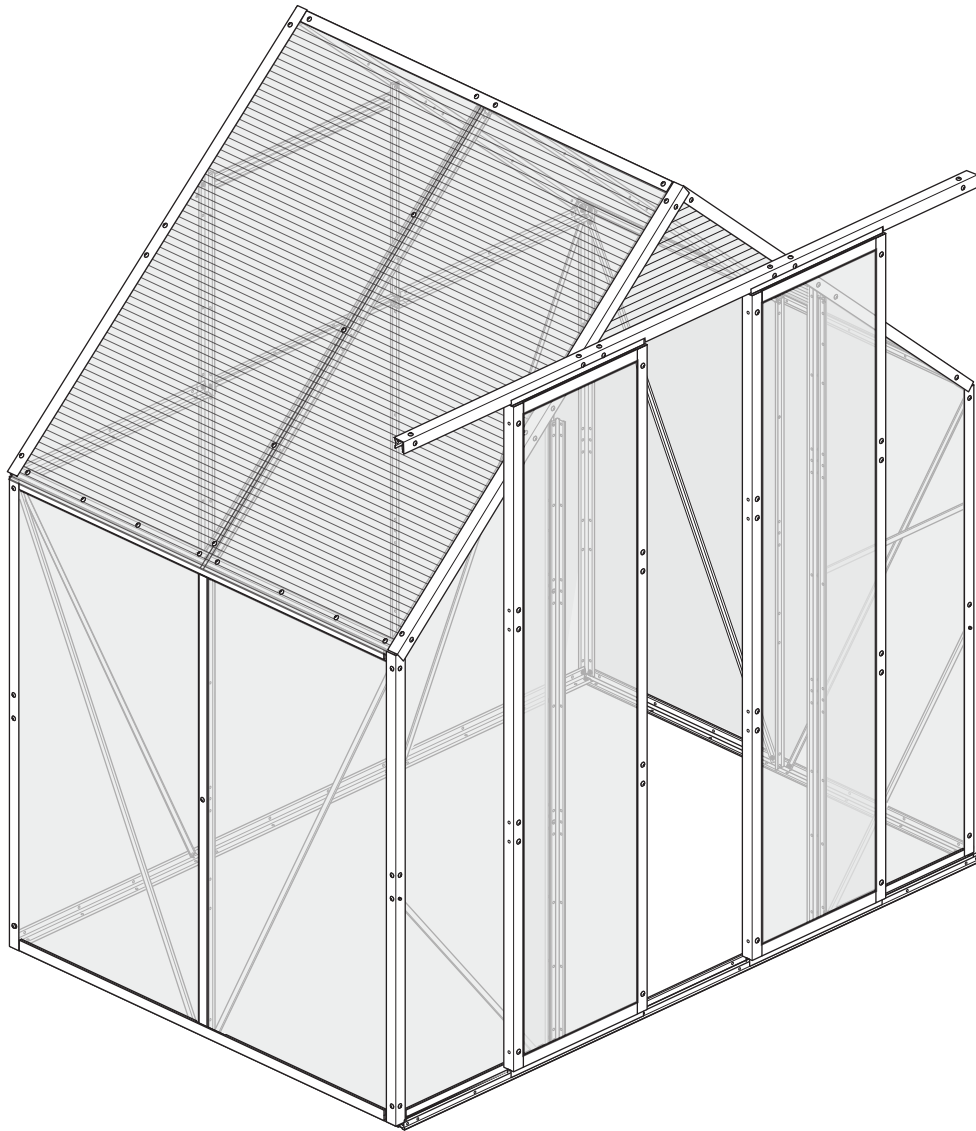

Ultimate Greenhouse 1.2m

GHUG1220

Assembly Instructions

IMPORTANT: Please read these instructions thoroughly before starting the assembly.
Please check that you have all of the parts listed on pages 3 - 5 before starting the assembly.

If there are any damaged or missing parts, please call us on: 020 3011 2040.

These instructions should be kept in a safe place for future use.

Introduction

Thank you for your purchase of the Ultimate Greenhouse and we hope you get many happy hours of use from it.

If you need any advice during the erection, our offices are open for your call Monday - Thursday 9.00am to 5.00pm and Friday 9.00am to 2.00pm. Please ring us on this number **020 3011 2040**.

Please read through these instructions and familiarize yourself with the construction before you begin.

If you cannot complete your construction in a day, leave the covering for another day so as not to leave the greenhouse half covered over night. As soon as covering has been completed make sure it is securely fixed to the ground.

Our policy is of continuous product improvement and we reserve the right to change specification without prior notice, therefore the latest model is supplied.

Contents

| | |
|-----------------------------------|-----|
| General Information..... | 2 |
| Hints and Tips..... | 2 |
| Parts | 3-5 |
| Groundworks | 6 |
| Door end assembly..... | 8 |
| Window end assembly..... | 12 |
| Making-up assemblies..... | 15 |
| Cladding door end and side..... | 17 |
| Cladding window end and side..... | 21 |
| Cladding the roof | 24 |
| Door assembly..... | 26 |
| Door Installation..... | 28 |
| Completing the Installation | 29 |
| Maintenance..... | 29 |
| Troubleshooting..... | 30 |
| Further Information..... | 30 |

General Information

General

- DO ask someone for help during assembly.
- Boxes are heavy don't try lifting them by yourself, get some help.
- Please check for any missing or broken part, it is essential that you advise us within the 10 days.
- **Caution:** Wear gloves when working with metal parts as some may have sharp edges.
- Keep children and pets away from the assembly area.
- Keep the area around your work place area clean and tidy.
- All framework is assembled with nuts on the inside except where stated.
- Protective film is fitted on both sides of the SAN panels and should be removed.
- Never leave your greenhouse partially assembled on a windy day.
- You are advised to take care and wear suitable protection where necessary.
- Make sure there are no underground cables or pipes, seek expert advice if necessary.
- All trim and glazing are fitted to the external side of framework.
- We suggest you add the greenhouse to your household insurance.

Ladders

- If you need to use a ladder during assembly, carefully follow all warnings and cautions supplied with the ladder.
- Take care when working at heights.
- The roof is not a load bearing structure.

Tools

- We advise that power tools are **NOT** used in the assembly of this product to tighten screws and bolts.
- Always use sharp tools, and never carry any sharp tools in your pocket.
- Follow the safety instructions provided with your tools.
- Always wear safety glasses, ear defenders and a face mask where applicable.
- If you have to use a power tool to fix your greenhouse to a base always use a RCD's (Residual Current Devices) never use in wet conditions.

Tools Required for Construction - Scissors, Flat screwdriver, Crosshead screwdriver, Bradawl, Junior hacksaw, Drill, 7mm Spanner.

Hints and Tips

All the metal parts are identified with the Part No. stamped towards one end, some also indicate which is the top, all other parts can be identified by measuring.

All framework is assembled with nuts on the inside except where stated.

Leave all bolts loose until the assembly is complete, then tighten.

Should you have any difficulty in lining up the holes on the framework, use a bradawl to help align the holes, alternatively use the supplied drill to enlarge one of the holes.

To eliminate condensation in the flutes of the twinwall panels, seal the ends using a silicone sealant.

To help you orientate the parts for the framework there are symbols (Ⓛ) placed over the part, see examples below.

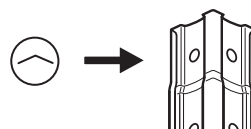
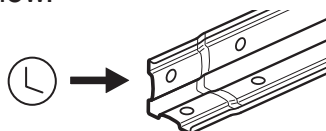

Parts - Metal

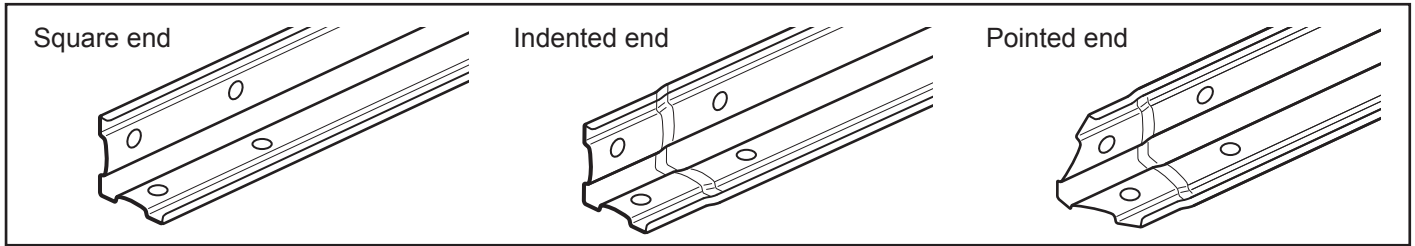

Please check that you have all of the parts listed on pages 3 - 5 before starting the assembly. If there are any damaged or missing parts, please call us on: **020 3011 2040**.

Parts - Metal 90° angle

| | | | | | | | |
|------------------------------|--|----------------------|--------|--|--|----------|--------|
| XL1 x 3 Square | | Square | 1178mm | XL47 x 4 Square | | Square | 1645mm |
| XL1S x 12 Pointed | | Indented | 1178mm | XL54 x 2 Square | | Square | 1758mm |
| XL2S x 2 Pointed | | Indented | 1704mm | XL56 x 2 Pointed | | Square | 1531mm |
| XL3 x 3 Square | | Square | 1758mm | XL55S x 2 Pointed | | Indented | 1593mm |
| XL8S x 2 Indented | | Indented extra holes | 598mm | GH-GDG x Pair Metal section fitted with trim and bolts (do not separate) | | | 1642mm |
| XL11-WD x 1 Square | | Square | 554mm | A8 x 4 Square | | Square | 396mm |

Note: some of these steel sections are packed in the PVC box.

Parts - Metal 135° angle

| | | | | | | | |
|--------------------------|--|--------|--------|--------------------------|--|--------|-------|
| XL6 x 2 Square | | Square | 1178mm | XL7 x 1 Square | | Square | 598mm |
|--------------------------|--|--------|--------|--------------------------|--|--------|-------|

Parts - Metal Channels

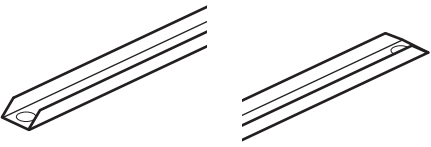
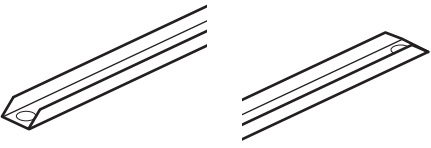
| | | |
|-----------------|---|--------|
| XL9 x 6 |  | 1266mm |
| XL57 x 2 |  | 703mm |

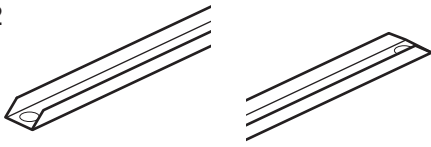
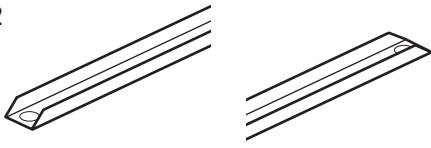
| | | |
|-----------------|--|-------|
| XL58 x 2 |  | 387mm |
| XL59 x 2 |  | 468mm |

Parts - Plastic Angle Trim

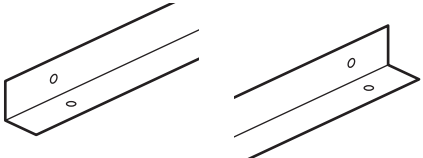
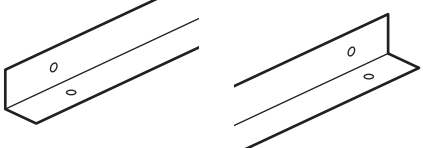
| | | |
|-----------------|---|--------|
| A12A x 9 |  | 1193mm |
| A15A x 3 |  | 1655mm |

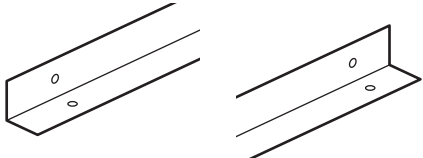
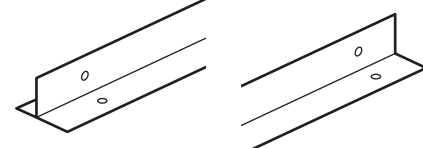
| | | |
|-----------------|--|--------|
| A17A x 1 |  | 1760mm |
| T10A x 1 |  | 1655mm |

Parts - Plastic Trim

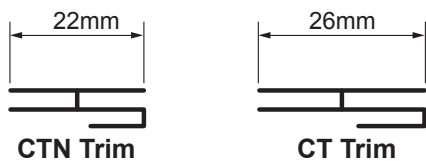

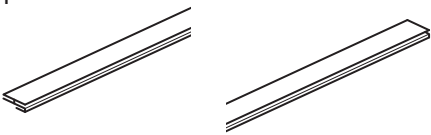
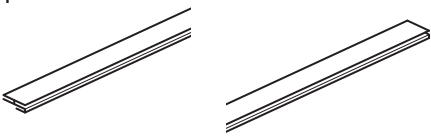
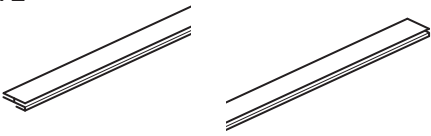
| | | |
|-------------------|---|--------|
| CTN4A x 1 |  | 1717mm |
| CTN8A x 4 |  | 1135mm |
| CTN11A x 2 |  | 435mm |

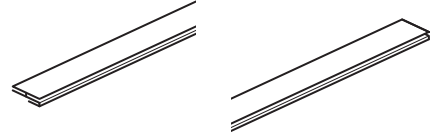
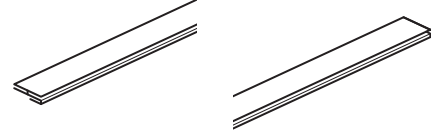
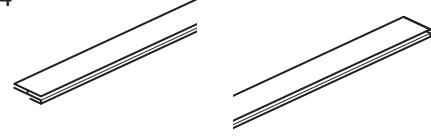
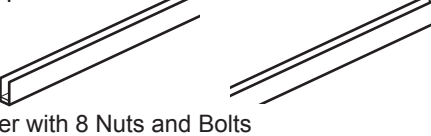
| | | |
|------------------|--|--------|
| CT2A x 3 |  | 550mm |
| CT8A x 2 |  | 1135mm |
| CT12A x 4 |  | 350mm |
| U1/WH x 4 |  | 396mm |

26mm

26mm

26mm

Door runner with 8 Nuts and Bolts

Parts - Panels

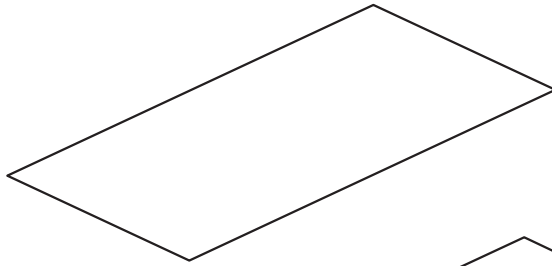

SAN1 Side panel x 7
1155mm x 575mm

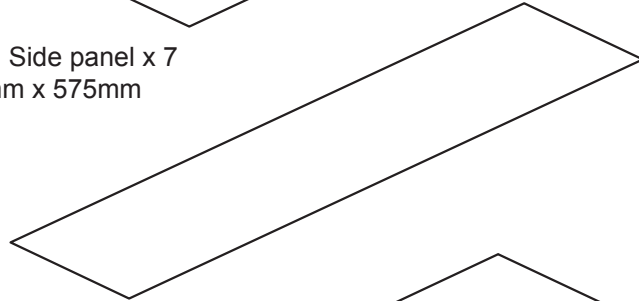

SAN18 Door panel x 2
1625mm x 373mm

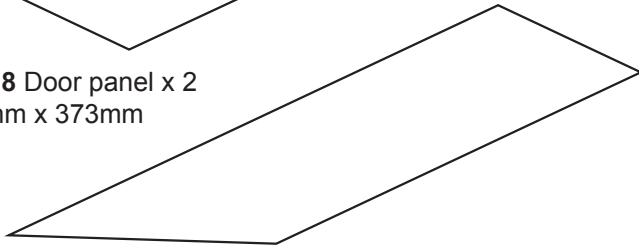

SAN17 Front panel x 2

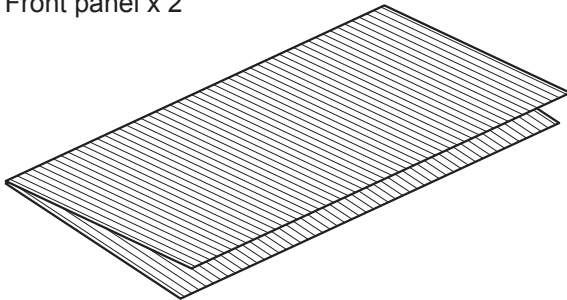

TW81 Roof panel (folded) x 2
1205mm x 1180mm

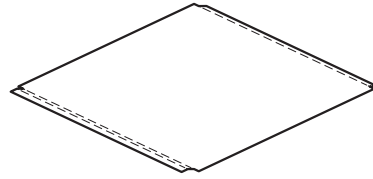

SAN15 Window panel x 1

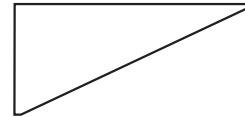

SAN12 Back side triangle x 2

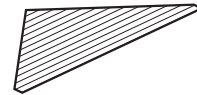



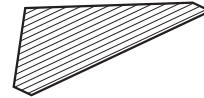



TW87 Front triangle x 1

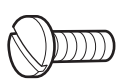

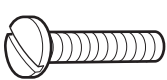
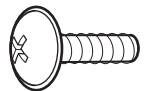
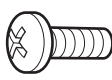
TW88 Back triangle x 1

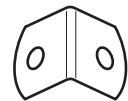
Parts - Hardware

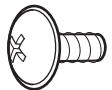
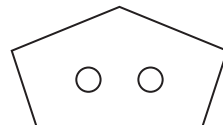
| | | |
|--|---|--|
| <p>A 8mm Bolt x 89</p>  | <p>B Flanged nut x 114</p>  | <p>C 16mm Bolt x 15</p>  |
| <p>D 1/2" Self tapping screw x 88</p>  | <p>E 10mm Bolt x 8</p>  | <p>F Square nut x 8</p>  |
| <p>G Door bracket x 1</p>  | <p>H 4mm Drill bit</p>  | <p>I 3/8" Self tapping screw x 24</p>  |
| <p>B4 Eave bracket x 4</p>  | | |

Groundworks

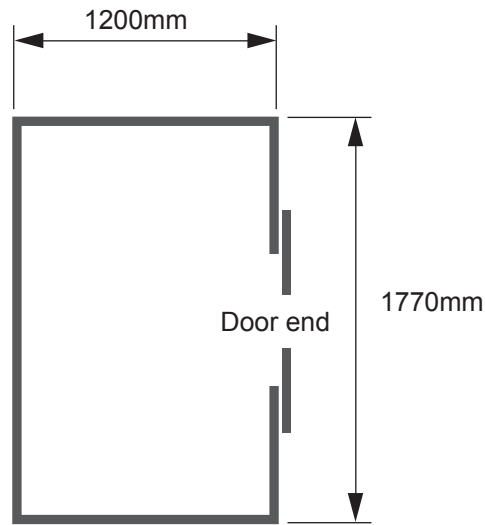

If you do not have a suitable hard standing for your Greenhouse, below are a few suggestions taken from customer feedback.

Whatever hard standing you have, your Greenhouse **must** be fixed to it, see below (fixings not supplied).

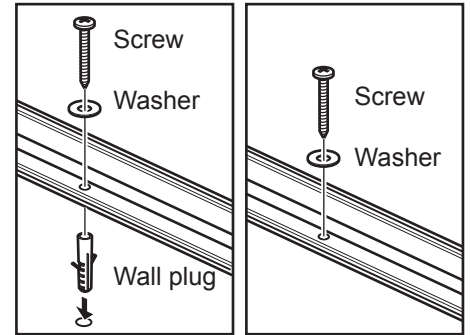

For concrete

For wood

Concrete Blocks

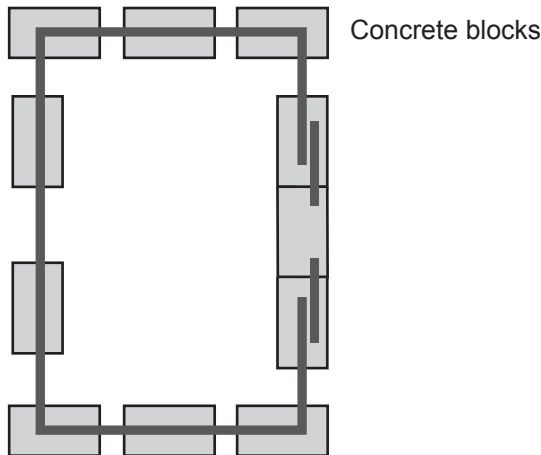

Dig out holes and position concrete blocks so that the tops are all level, ensure that the holes in the framework of your greenhouse are central to each block.

Once the position of all the blocks is correct, part fill the remaining holes with concrete. Once concrete has set, the remaining hole can be filled with soil.

Fix your greenhouse down to the centre of the blocks using suitable wall plugs and screws with washers.

Patio Slabs

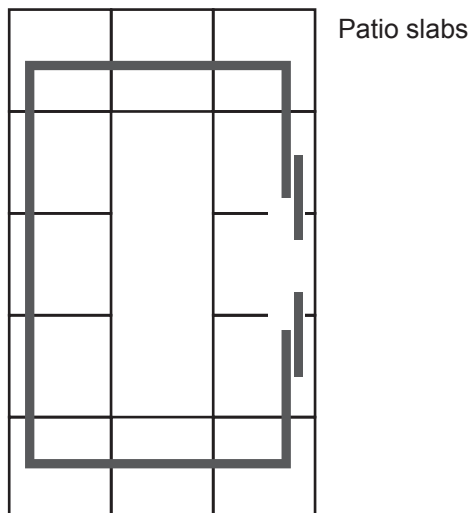

This method requires patio slabs laid out and concreted down.

Fix your greenhouse down to each slab using suitable wall plugs and screws with washers.

Sleepers

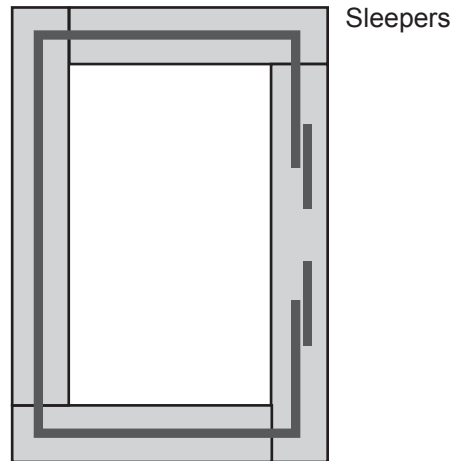

Lay the sleepers out in the required position, make sure all are level.
Fix through the greenhouse with suitable screws and washers.

Wooden Frame

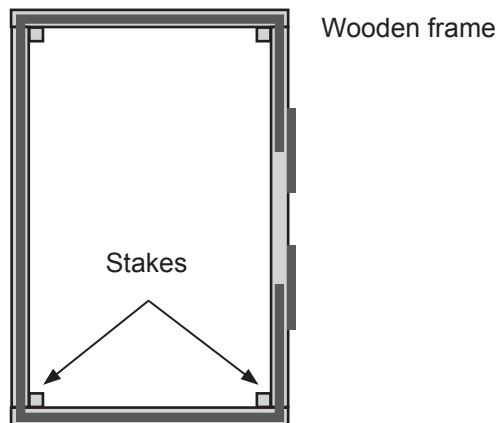
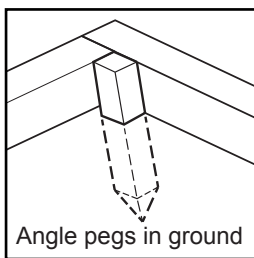

A wooden frame is made to the required size for the greenhouse making sure that the holes in the framework line up with the centre of the frame. Using a minimum of 4 stakes hammered into the ground at an angle. Level and screw the framework to each stake.

Fix the greenhouse in position with suitable screws and washers.

Concrete Slab

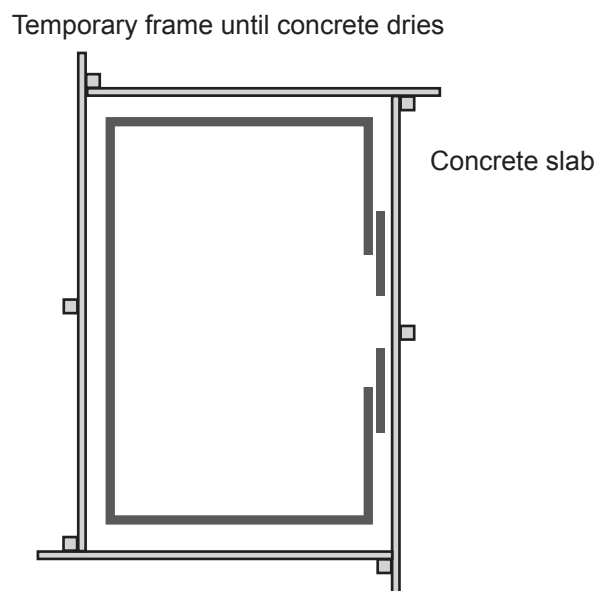

Dig out an area the size of your greenhouse, adding 300mm all round.

Using 3" boards construct a rectangle 200mm larger than the greenhouse. Hammer pegs into the ground on the outside of the frame, fix the frame to the pegs making sure that the frame is level in both directions.

Using a mix of all-in ballast and cement at a ratio of 5 parts ballast to 1 part cement. Fill the frame with the concrete tamping down as you go, making sure that it is pushed into the corners. Use a length of wood long enough to cover the frame and tamp down until the concrete is level with the top of the framework.

Allow to dry slowly for several days and remove the framework.

Fix your greenhouse down using suitable wall plugs and screws with washers.

Step 1 - Door end assembly

For illustrative purposes, the frame is shown in the upright position, you may find it easier to assemble it flat on the ground.

This frame is shown viewed from the outside.

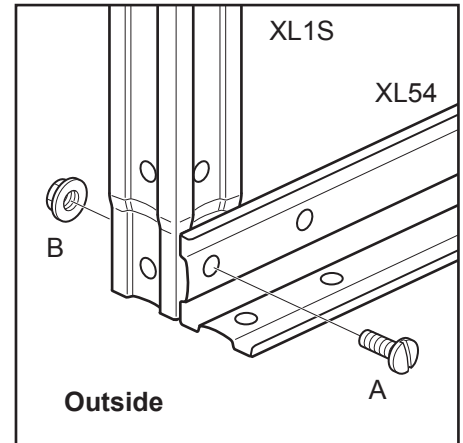
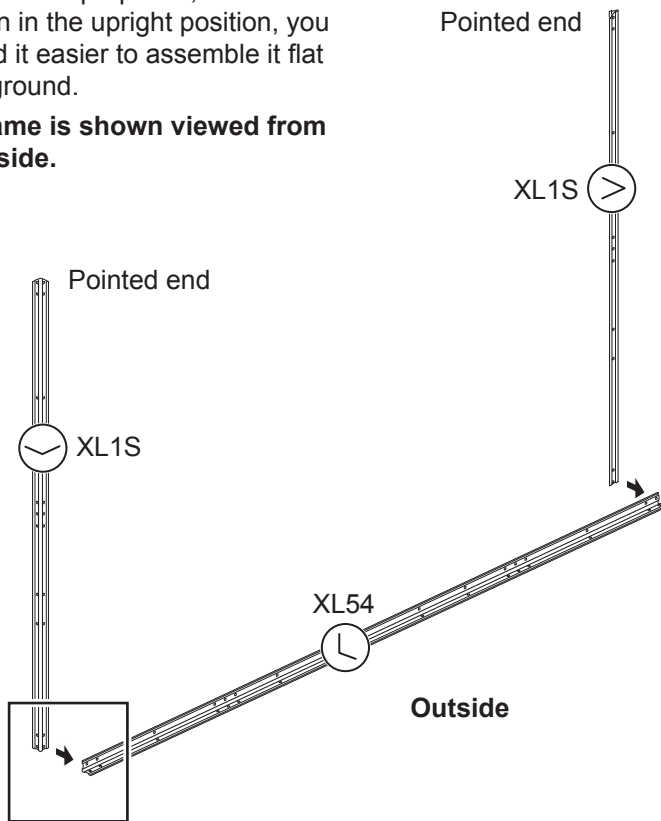

Start by laying down the base frame XL54 with the angle pointing towards the outside.

Using bolts A and nuts B, bolt on uprights XL1S, with the pointed ends to the top.

Note: All bolts are fitted from the outside, except where stated.

Step 2 - Door end assembly

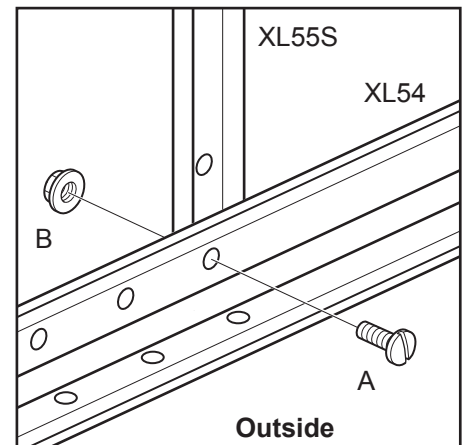
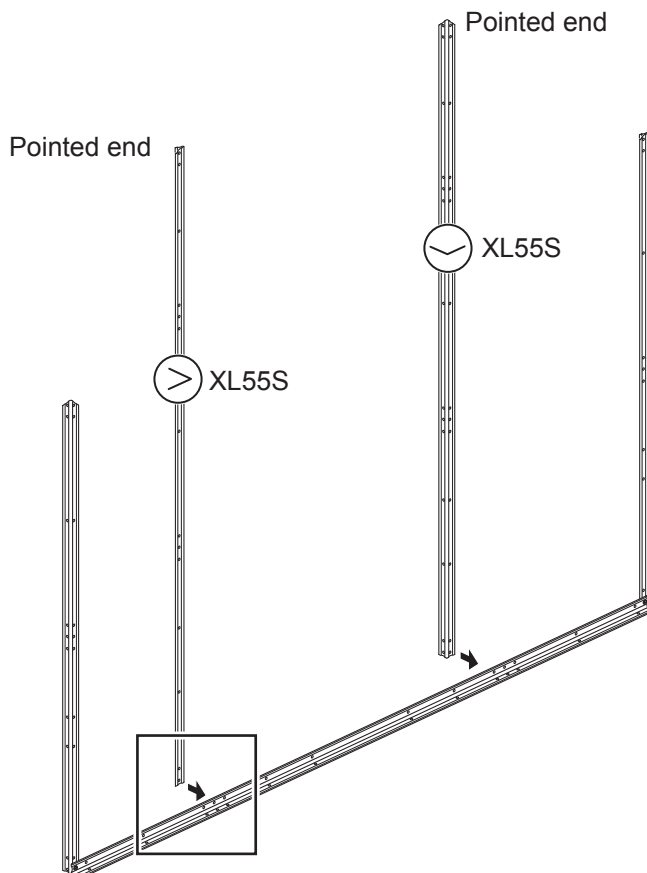

Using bolts A and nuts B, bolt on uprights XL55S onto the inside hole of the 3 in XL54. The pointed ends should be to the top with the angle on the inside.

Step 3 - Door end assembly

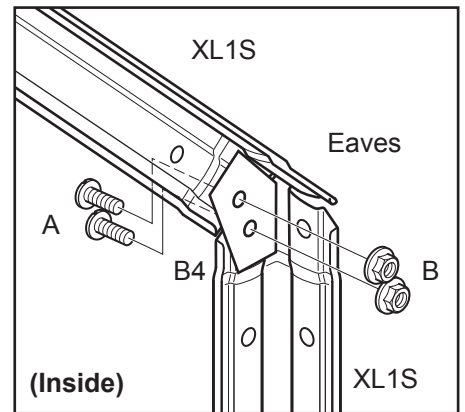
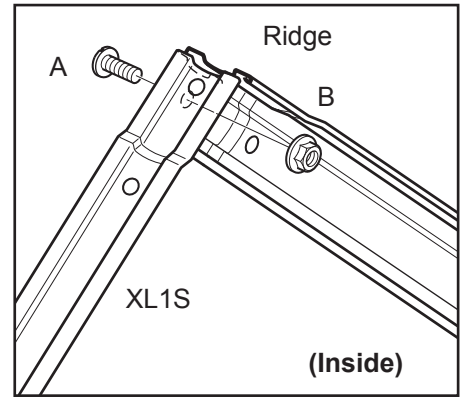
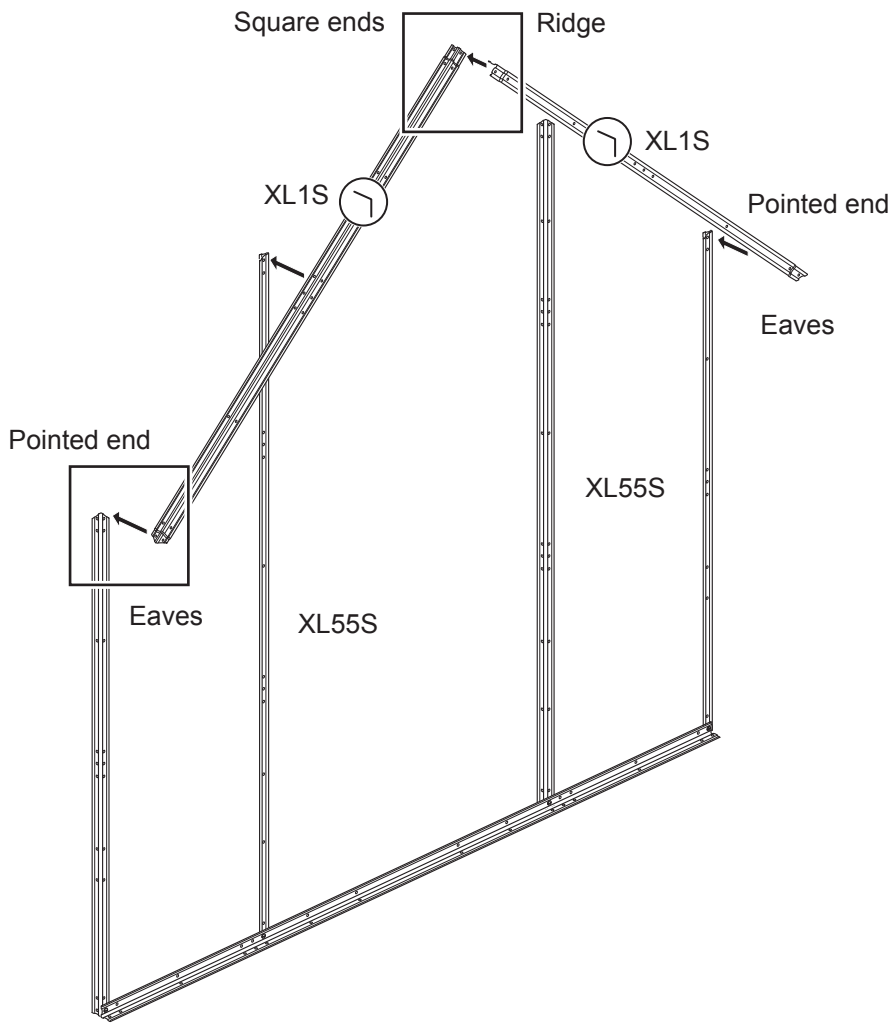

On both eaves, bolt together the pointed ends of the 2 XL1S using the plate B4 on the inside (see detail above).

Using a bolt A and nut B bolt together the 2 square ends XL1S at the ridge.

Bolt together the 2 uprights XL55S to the roof XL1S using the top hole of the 3.

Step 4 - Door end assembly

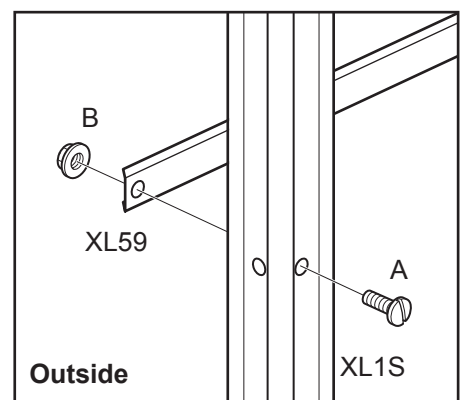
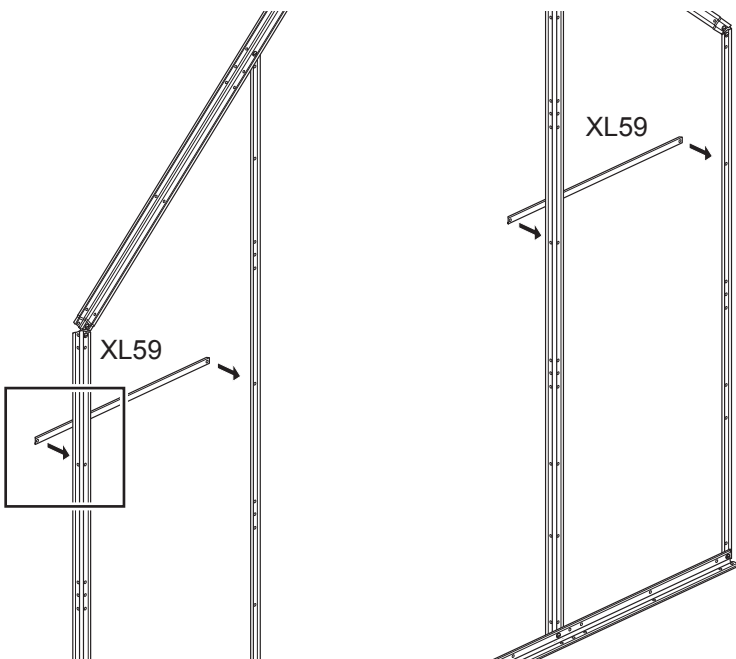

Using the third hole down from the top, bolt XL59 to the inside of XL1S and XL55S.

The bolts should fit from the outside.

Step 5 - Door end assembly

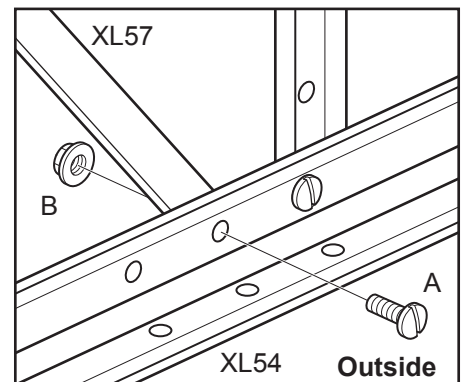
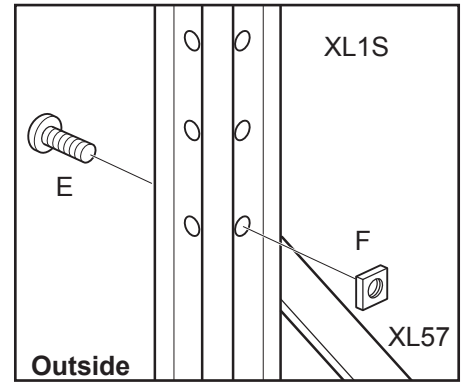
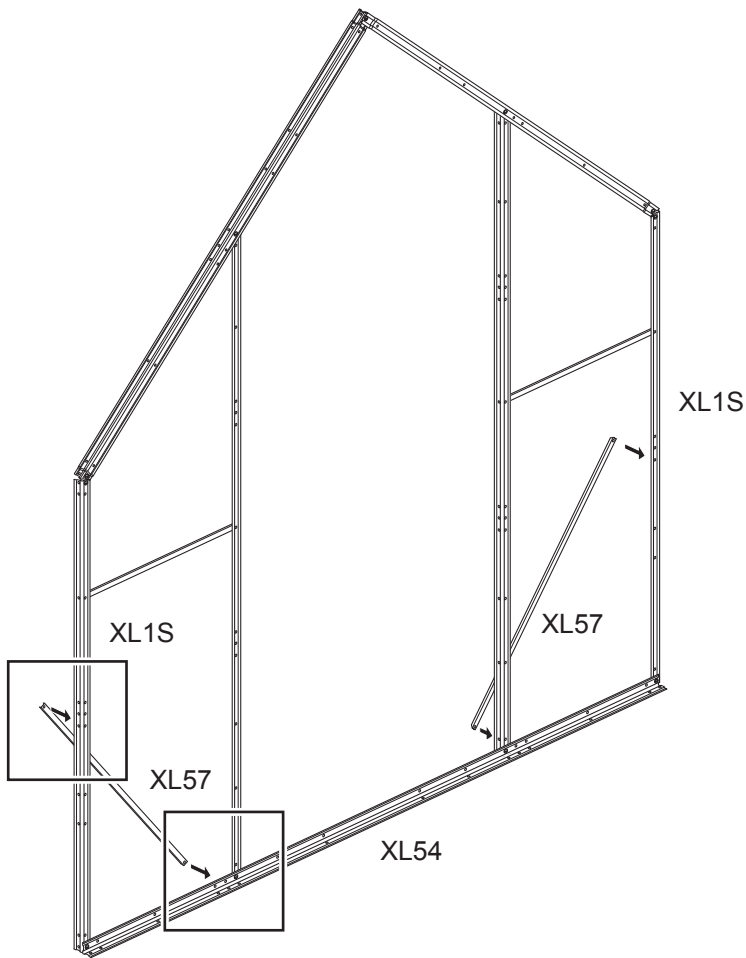

Using the bottom hole of the 3 on XL1S, bolt XL57 to the inside using bolt E and square nut F.

Note: the bolt should be fitted from the inside with the nut on the outside.

At the bottom bolt XL57 to XL54 using bolt A and nut B into the middle hole. The bolt should fit from the outside.

Now tighten all bolts.

Step 6 - Door end assembly

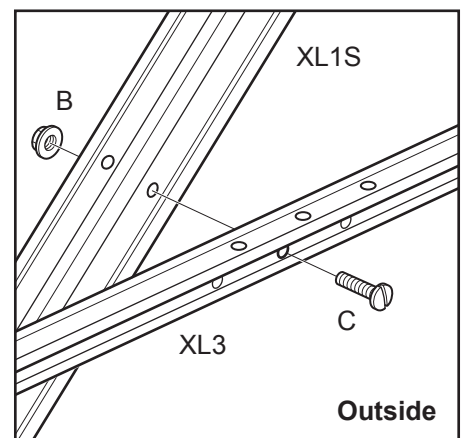
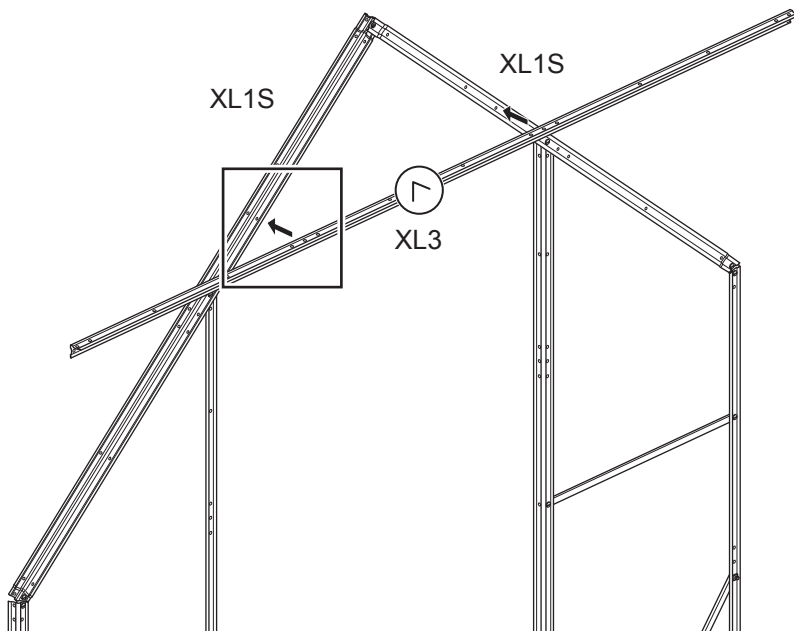

Temporarily bolt XL3 to the frame, you will need to remove it later when covering.

Using the middle hole of the 3, bolt XL3 to the 2 roof angles XL1S

The bolt should fit from the outside.

Step 7 - Door end assembly

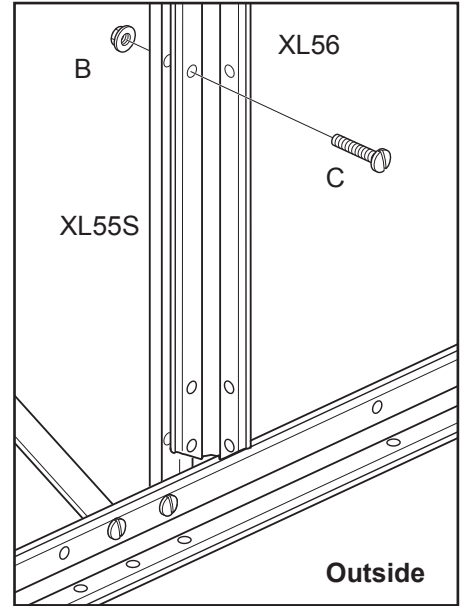
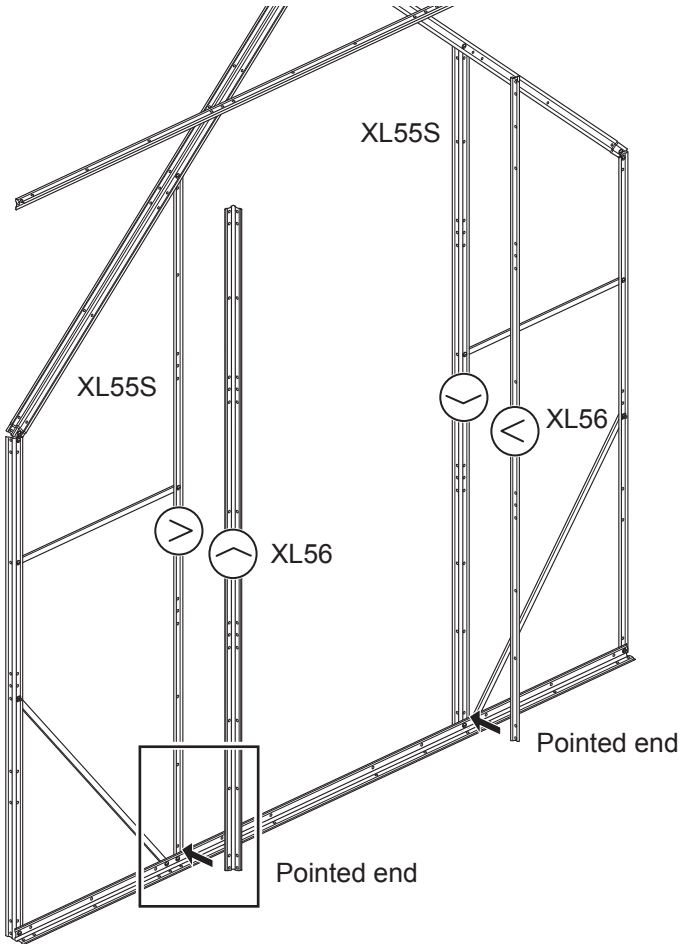

Bolt XL56 to XL55S, the pointed end should be at the **bottom**. Use 3 long bolts C with nuts B.

Note: For the bottom bolt use the 3rd hole up from the bottom.

Leave loose do not tighten.

Step 8 - Door end assembly

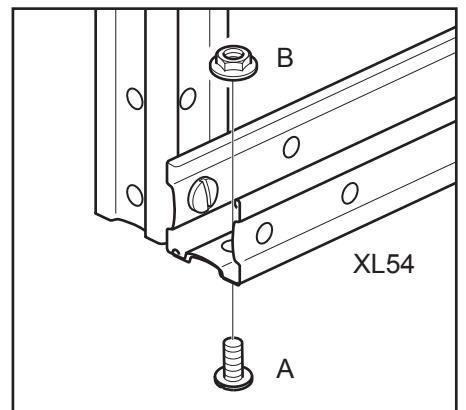
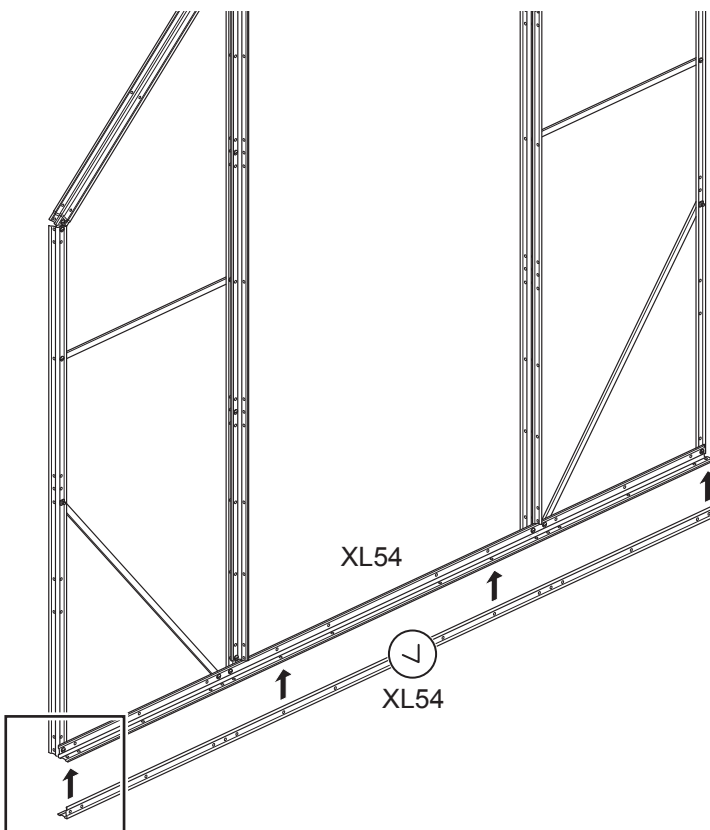

Place a second XL54 under the first to create a U section and bolt together with 4 bolts A from the underside, 4 nuts B from the top and tighten.

Step 9 - Window end assembly

For illustrative purposes, the frame is shown in the upright position, you may find it easier to assemble it flat on the ground.

This frame is shown viewed from the inside.

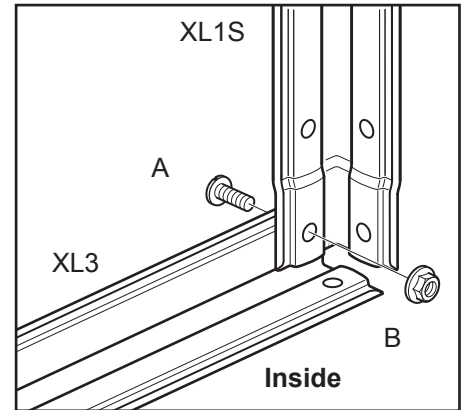
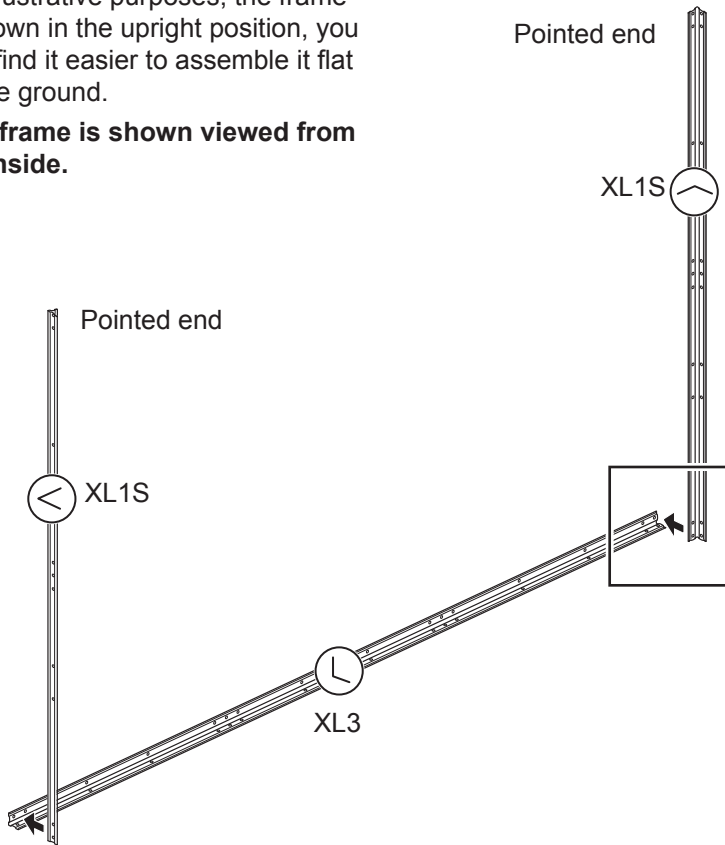

Start by laying down the base frame XL3.

Using bolts A and nuts B, bolt on uprights XL1S, with the pointed ends to the top.

Note: All bolts are fitted from the outside, except where stated.

Step 10 - Window end assembly

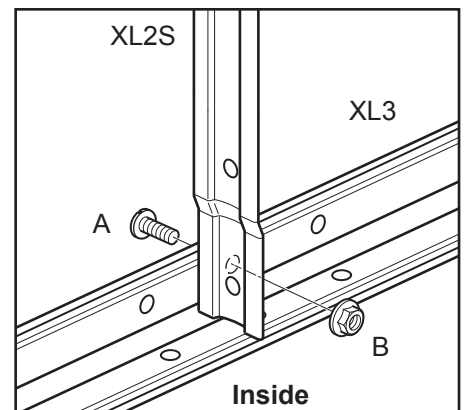
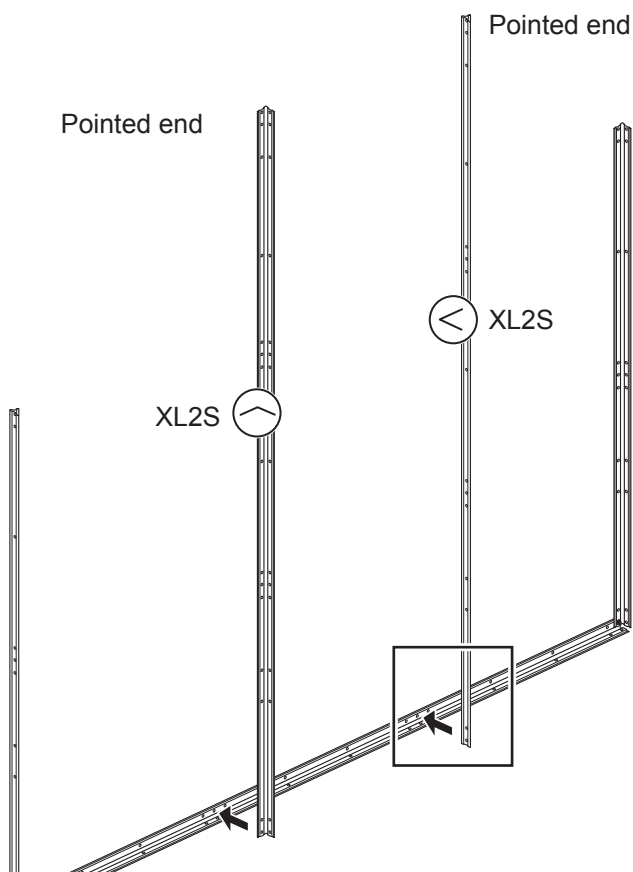

Using bolts A and nuts B, bolt on uprights XL2S onto the middle hole of the 3 in XL3. The pointed ends should be to the top with the angle on the inside.

Step 11 - Window end assembly

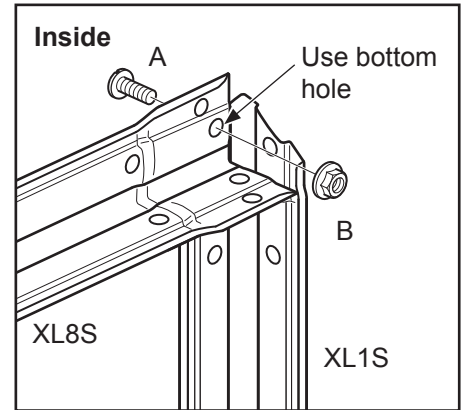
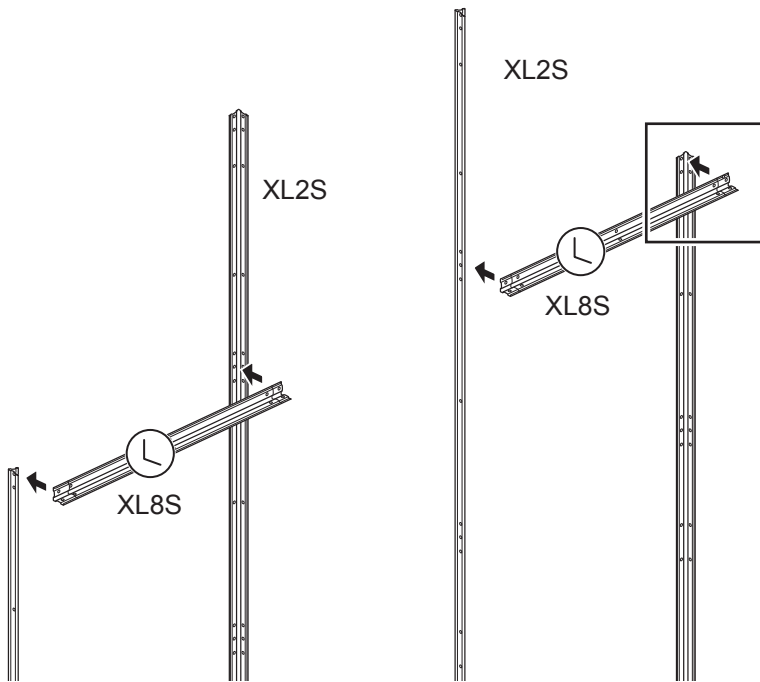

Bolt XL8S in between XL1S and XL2S using bolts A and nuts B.
 Use the bottom hole of the 2 where it joins to XL1S (see above).
 Where XL8S joins the upright XL2S use the middle hole of the 3.

Step 12 - Window end assembly

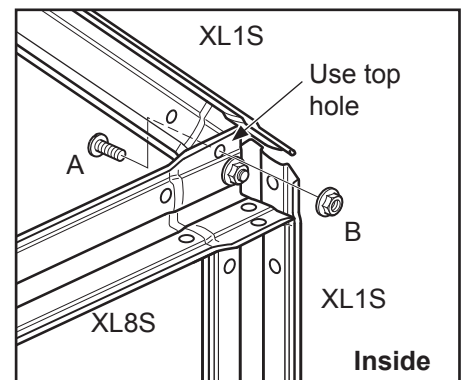
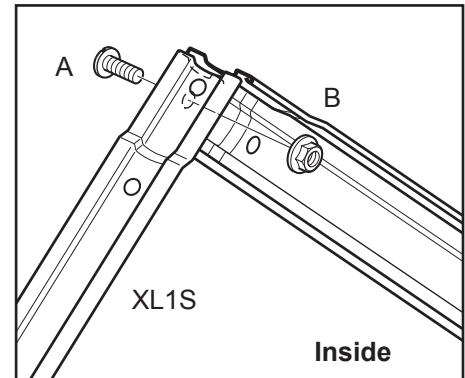
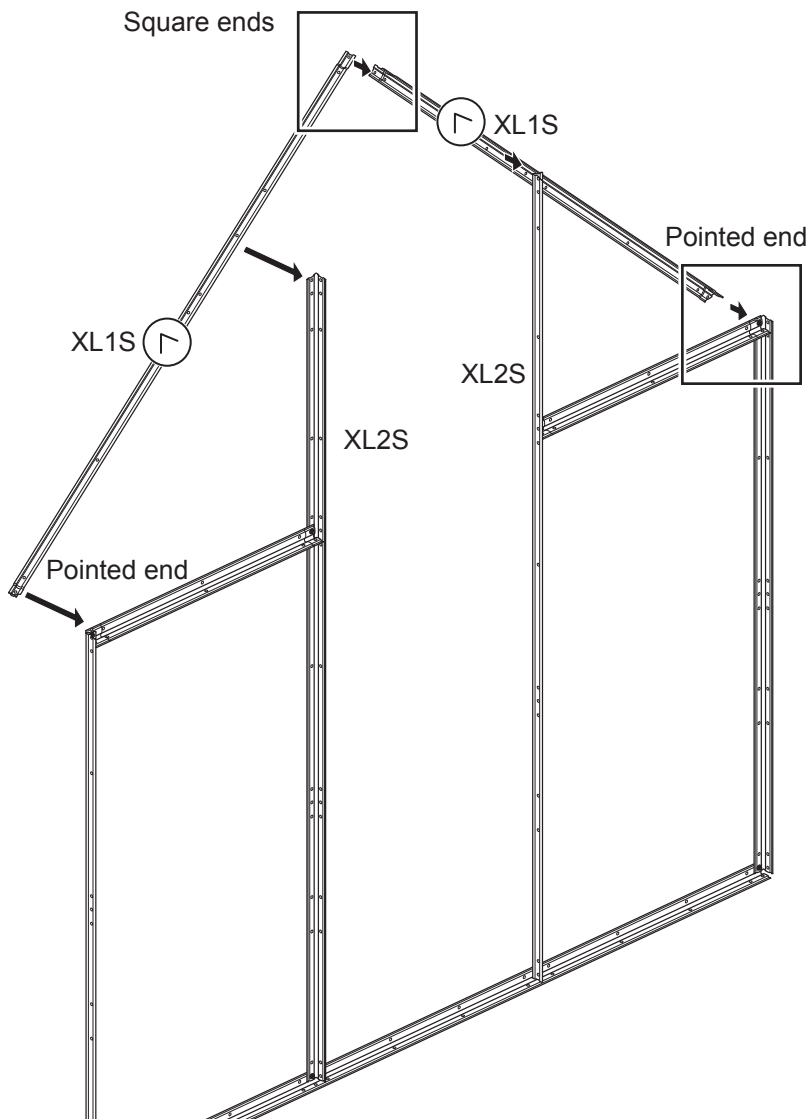

On both eaves bolt together the pointed end of the XL1S to XL8S using the top hole in XL8S (see detail above).
 Using a bolt A and nut B, bolt together the 2 square ends XL1S at the ridge.
 Bolt together the 2 uprights XL2S to the roof XL1S.

Step 13 - Window end assembly

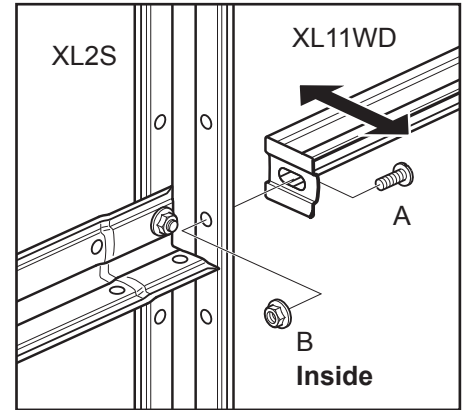
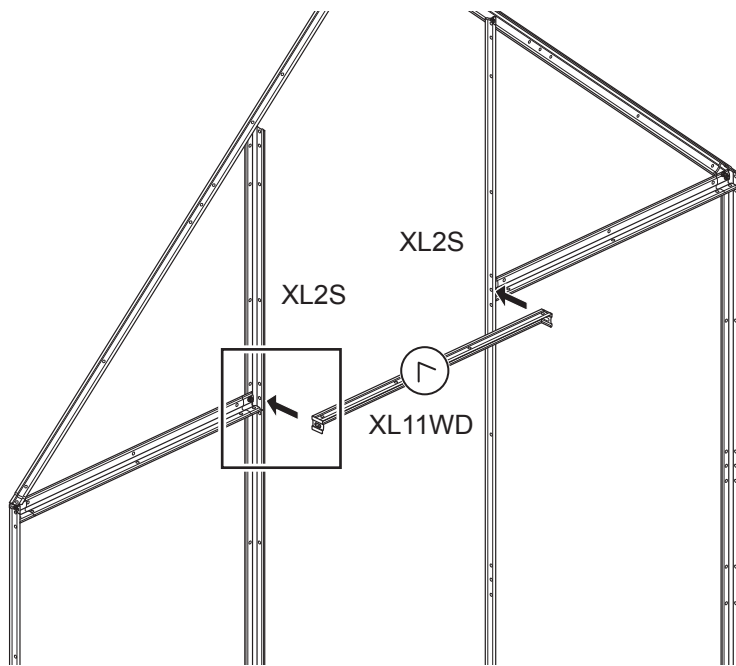

Bolt XL11WD in between the 2 uprights XL2S using bolts A and nuts B.

Adjust XL11WD in or out so it is flush with the outside face of XL2S, then tighten.

Step 14 - Window end assembly

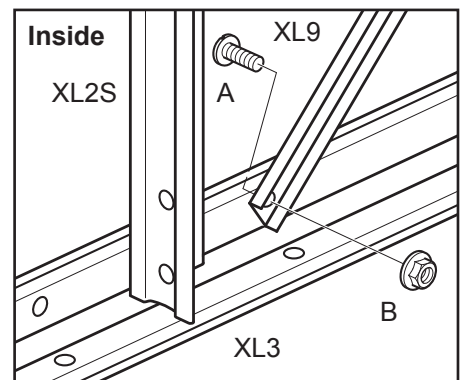
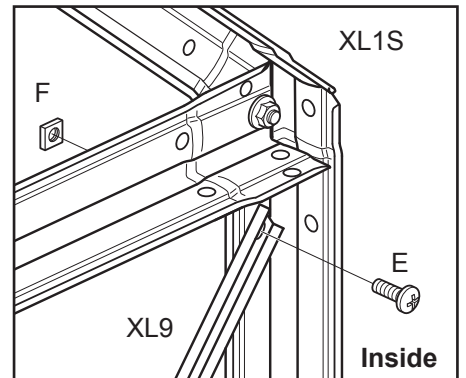
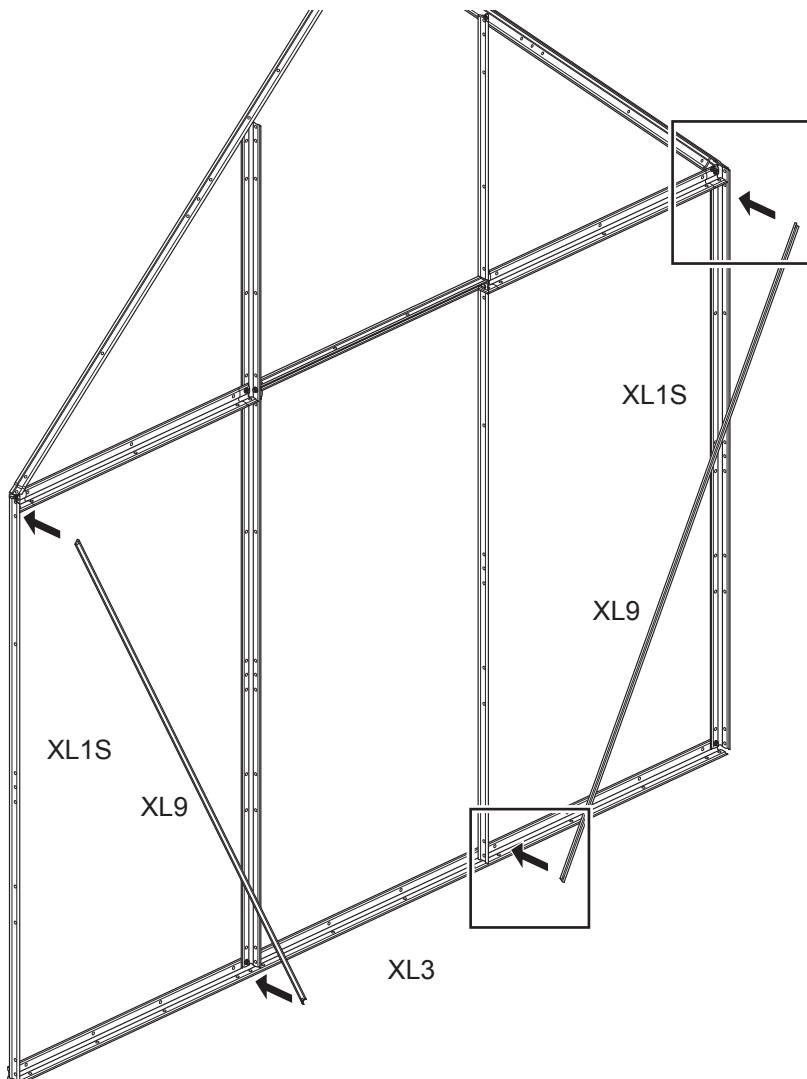

At the top bolt XL9 to the inside using bolt E and square nut F.

Note: the bolt should be fitted from the inside with the nut on the outside.

At the bottom bolt XL9 to XL3 using bolt A and nut B. The bolt should fit from the outside.

Now tighten all bolts.

Step 15 - Make-up assemblies

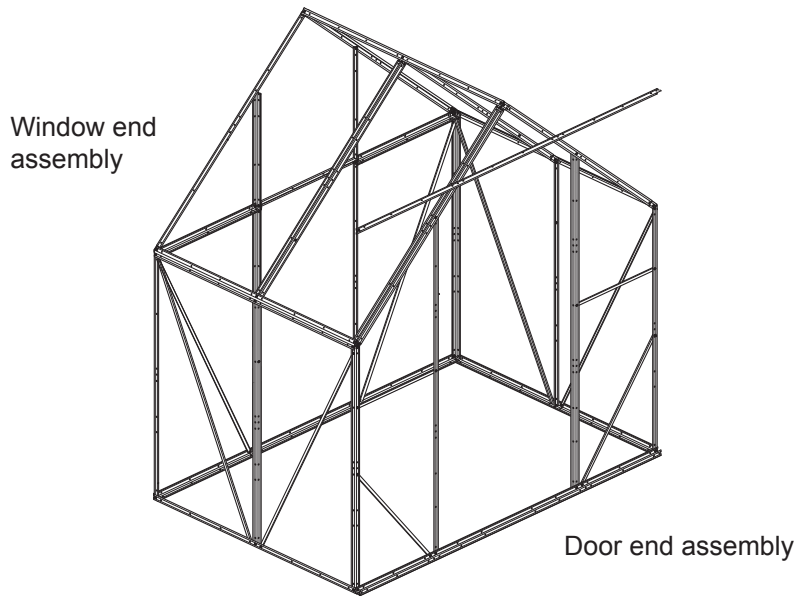

You now have to join together the door end assembly and window end assembly to complete the framework (see left).

Step 16 - Make-up assemblies

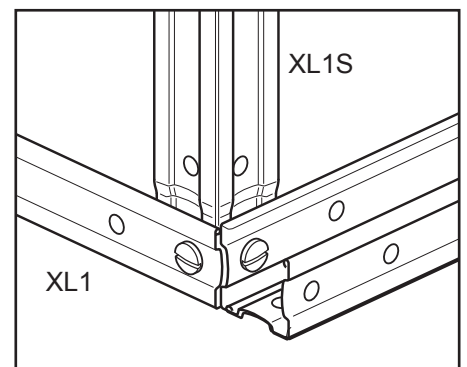
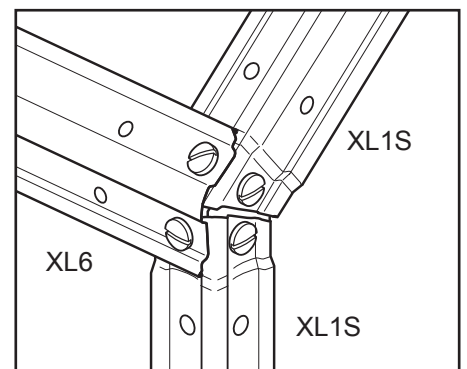
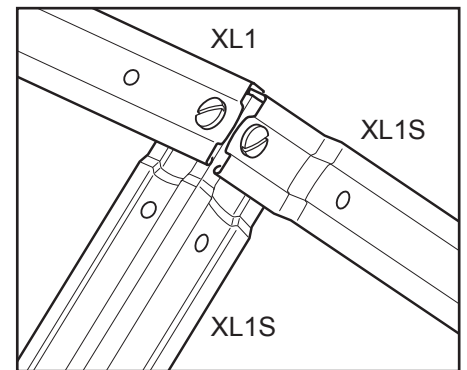
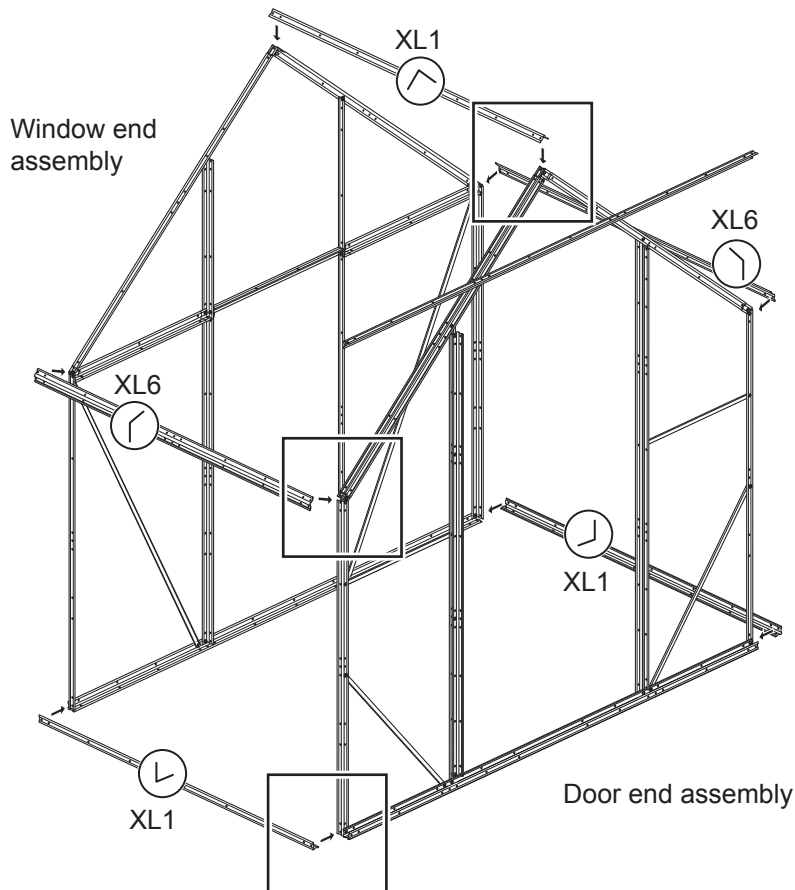

With help join the door assembly to the window end assembly.
Use 2 XL1 for the base and one for the ridge. On each of the eaves use an XL6.

Use bolts A and nuts B, all bolts should be fitted from the outside with nuts on the inside.
Bolt the ridge XL1 to both XL1S, use the drill or a bradawl to help fit the second screw.

Step 17 - Make-up assemblies

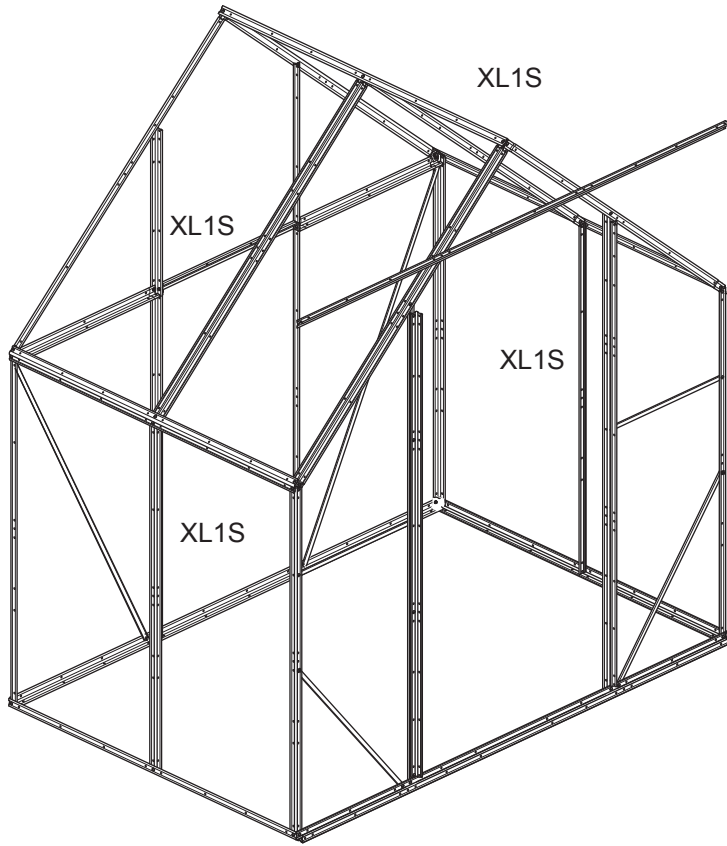

You now need to fit the 4 intermediate XL1S.

Use the same procedure as in previous steps (step 3).

Make sure that the pointed ends fit together at the eaves with the bracket B4.

Bolt each XL1S to XL6 and XL1 similar to step 16, use bolts A and nuts B in the middle hole.

Step 18 - Make-up assemblies

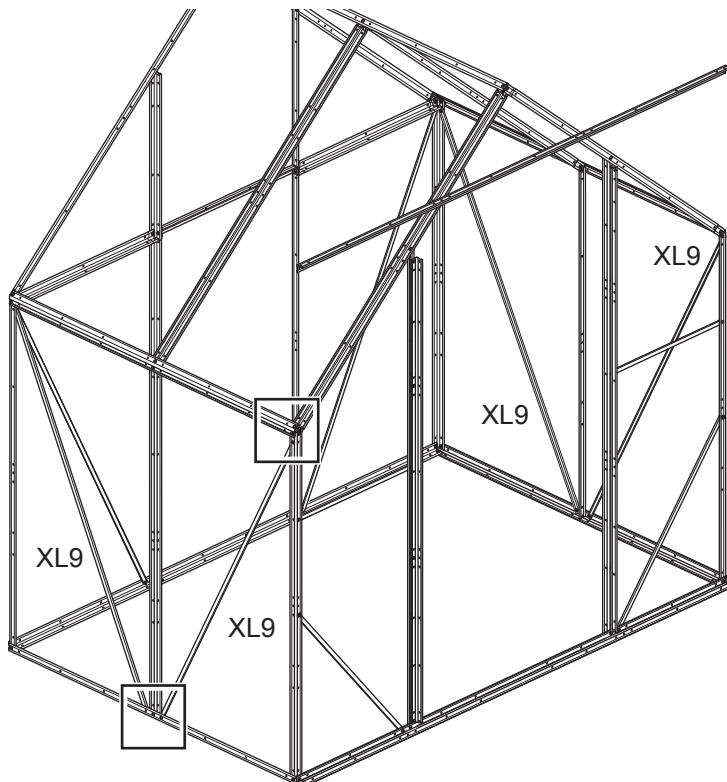

On each side bolt a XL9, from each top corner to the bottom XL1. Bolt XL9 to the top of XL1S, use bolt E and square nut F.

Note: the bolt should be fitted from the inside with the nut on the outside.

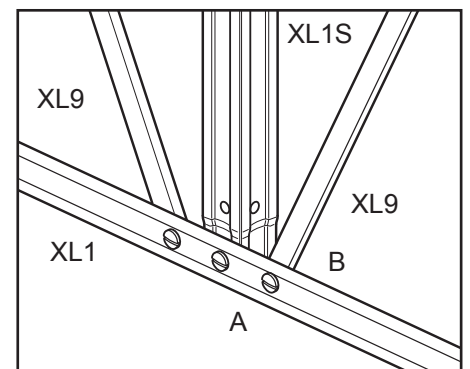
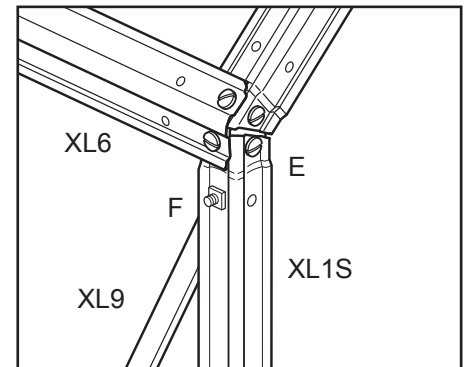

At the bottom bolt XL9 to XL1 using bolt A and nut B. The bolt should fit from the outside.

Now tighten all bolts

Step 19 - Cladding the door end and side

You now have to cover the assembled framework.

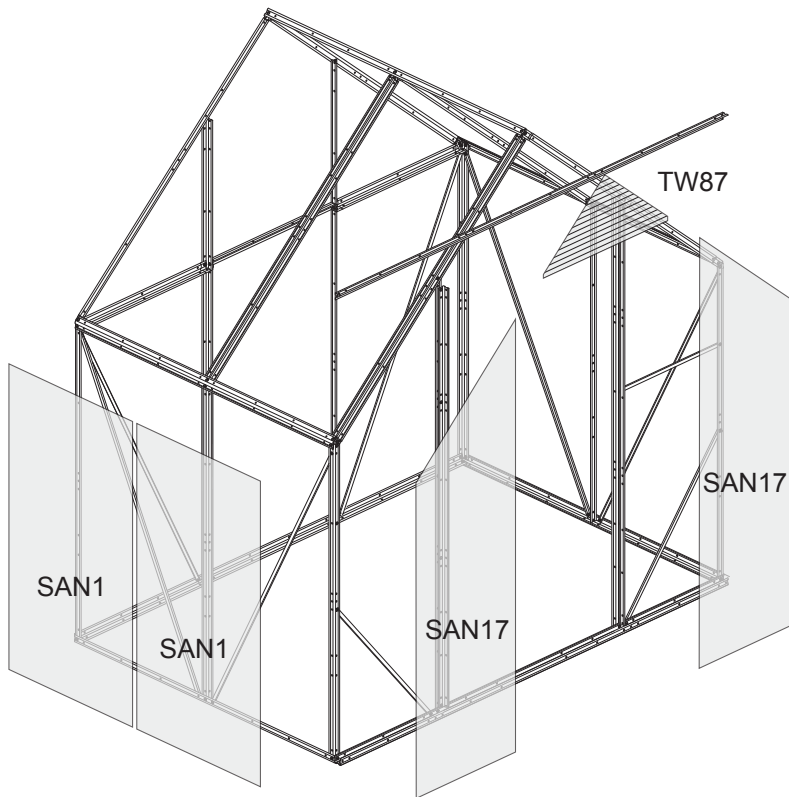

Use the clear SAN panels on the sides, they have clear film on both sides which should be removed before fitting.

The roof and the 2 top end panels are covered using Twinwall (TW) panels.

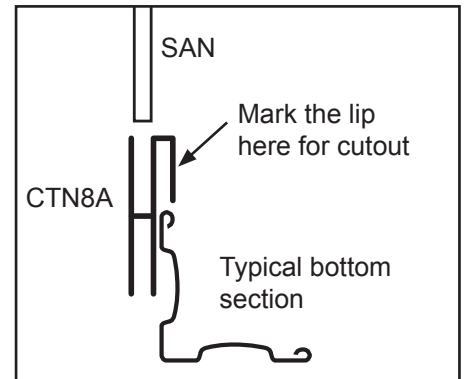

The clear panels (SAN) are held in position with plastic trims CTN8A. At various positions on the plastic trim CTN8A you will need to mark and cutout a section to fit in front of the uprights.

Step 20 - Cladding the door end and side

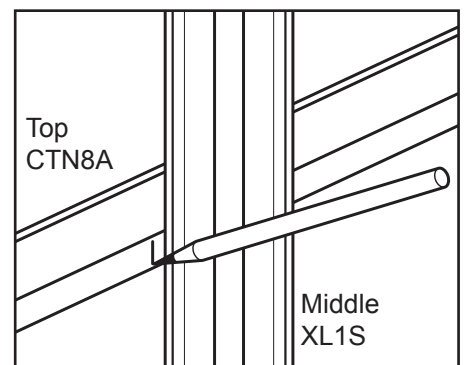
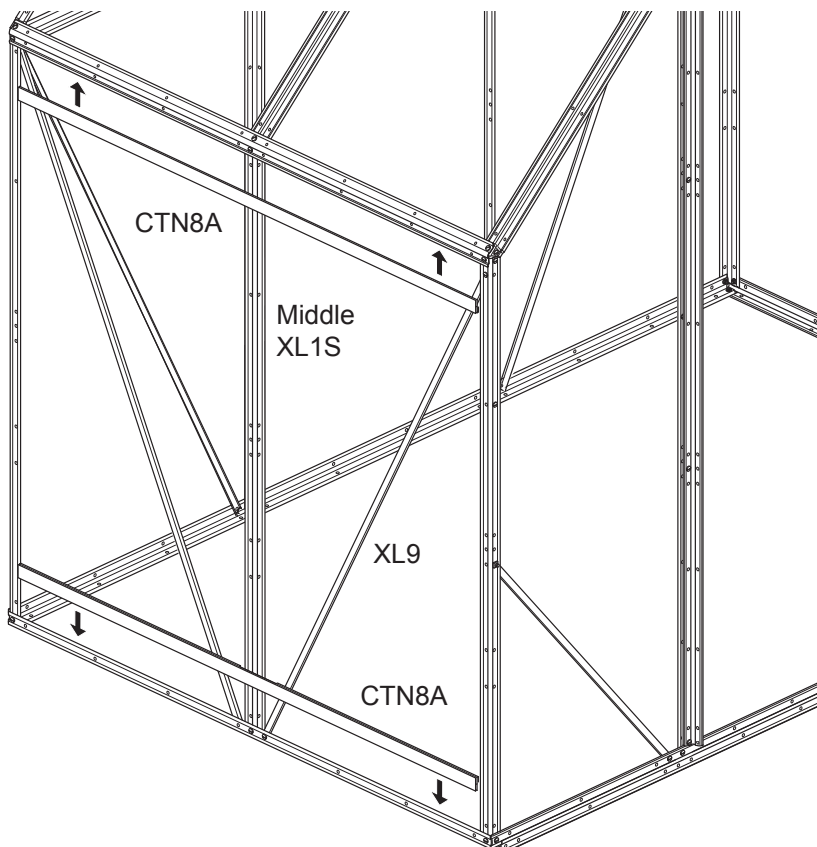

Start by covering the sides. You need to make some cutouts in CTN8A before fitting them to the framework. Offer up CTN8A in position in between the 2 end uprights, mark the position either side of the middle upright. Mark the smaller lip section of CTN8A.

Repeat the same procedure for the bottom CTN8A, here the cutout should be longer to allow for both XL9.

Remember that these trims are the opposite way round to each other.

Step 21 - Cladding the door end and side

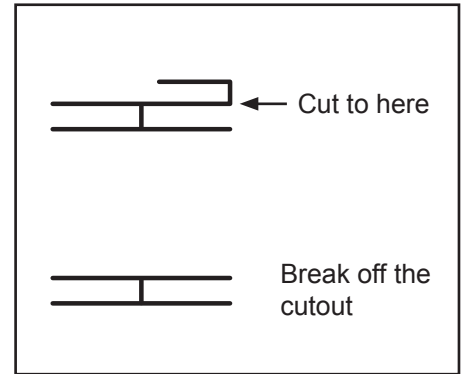
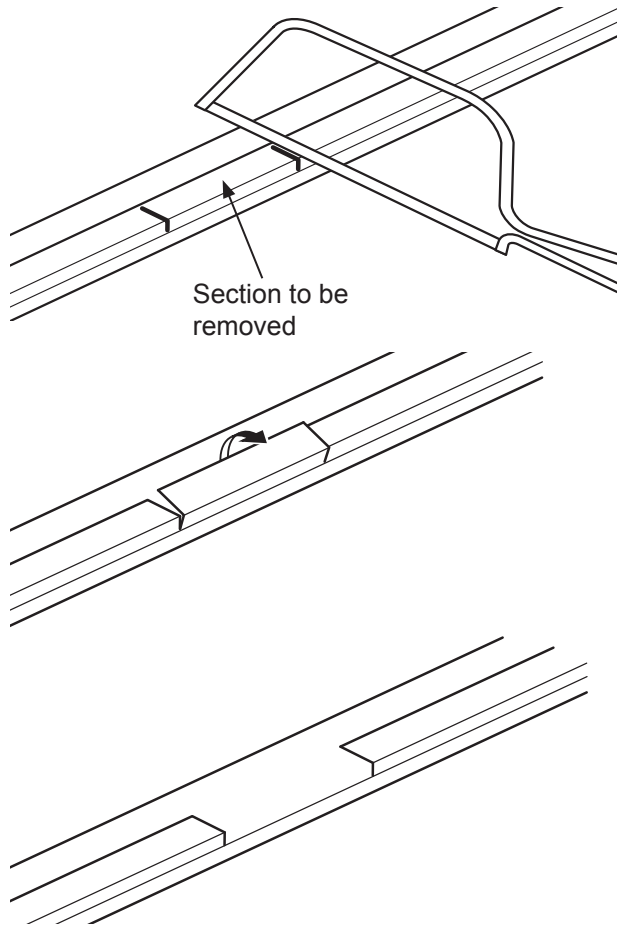

Using a knife/scissors or junior hacksaw cut across the small section of CTN8A where marked.

Bend back the small section to be removed until it breaks off, alternatively cut along the fold to remove.

Step 22 - Cladding the door end and side

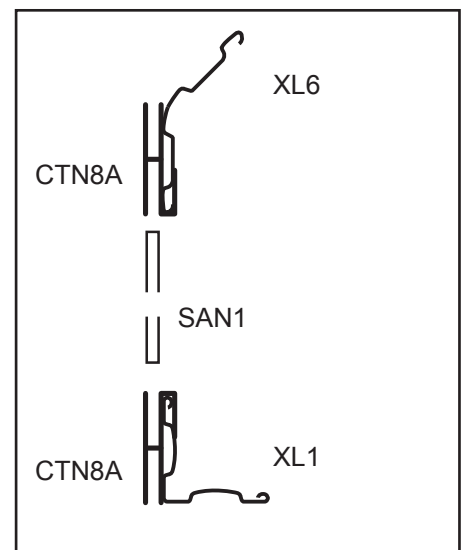
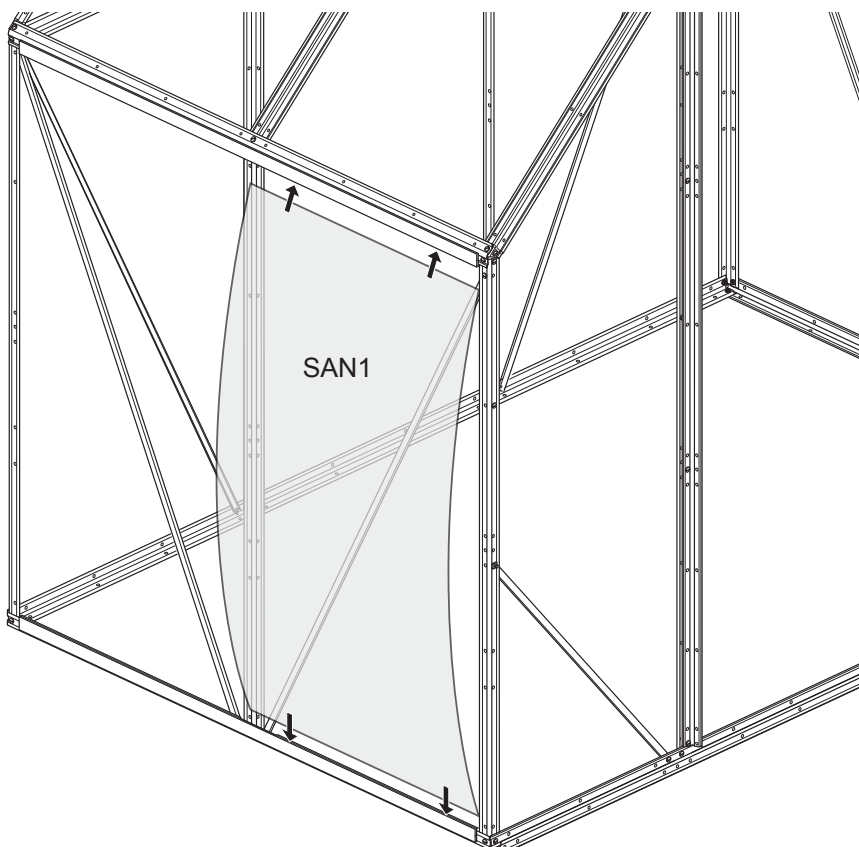

Slide both CTN8A, one into the top and one into the bottom.

Make sure that the "Lip" fits over the metal of XL1.

Take a side panel SAN1 and position into the bottom trim, making sure it fits into the slot and not behind.

Slightly bend the panel out to fit into the slot at the top.

Step 23 - Cladding the door end and side

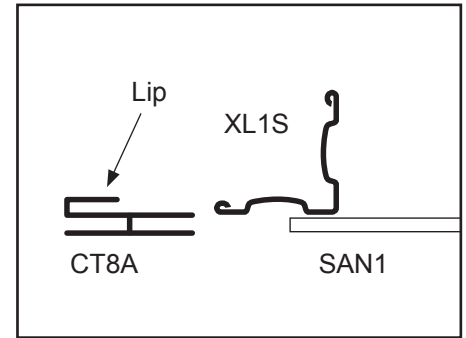
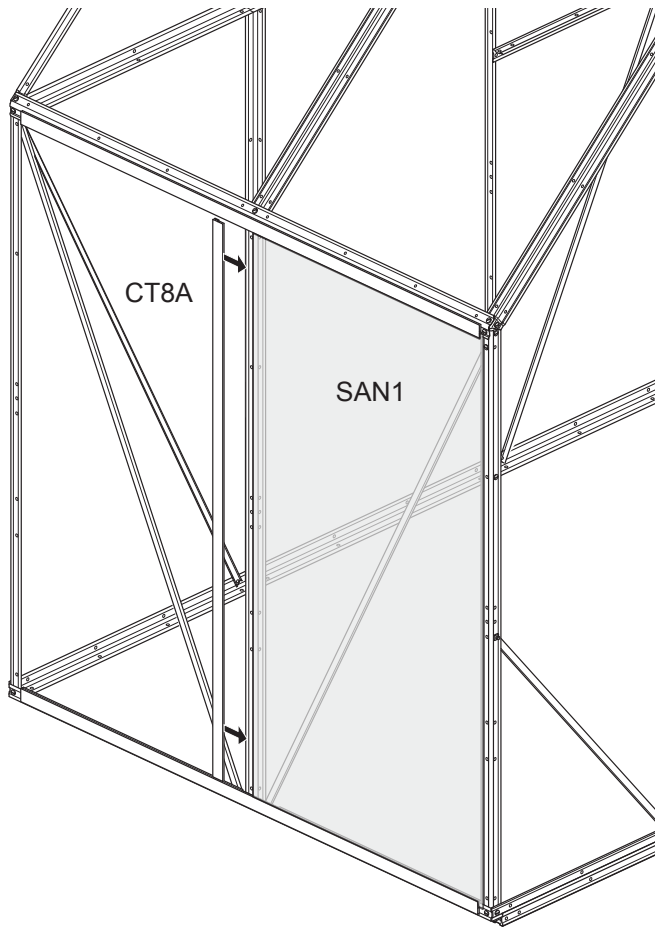

In the upright position slide on a CT8A, making sure that the lip fits over the metal frame XL1S and the groove fits over panel SAN1.

Step 24 - Cladding the door end and side

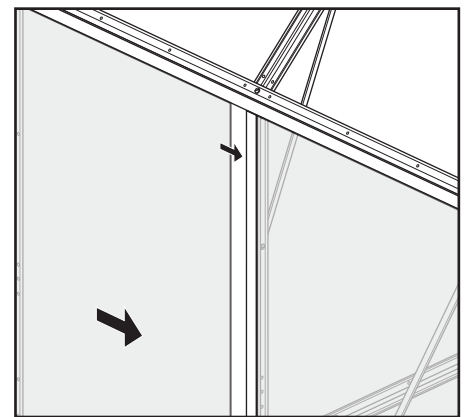
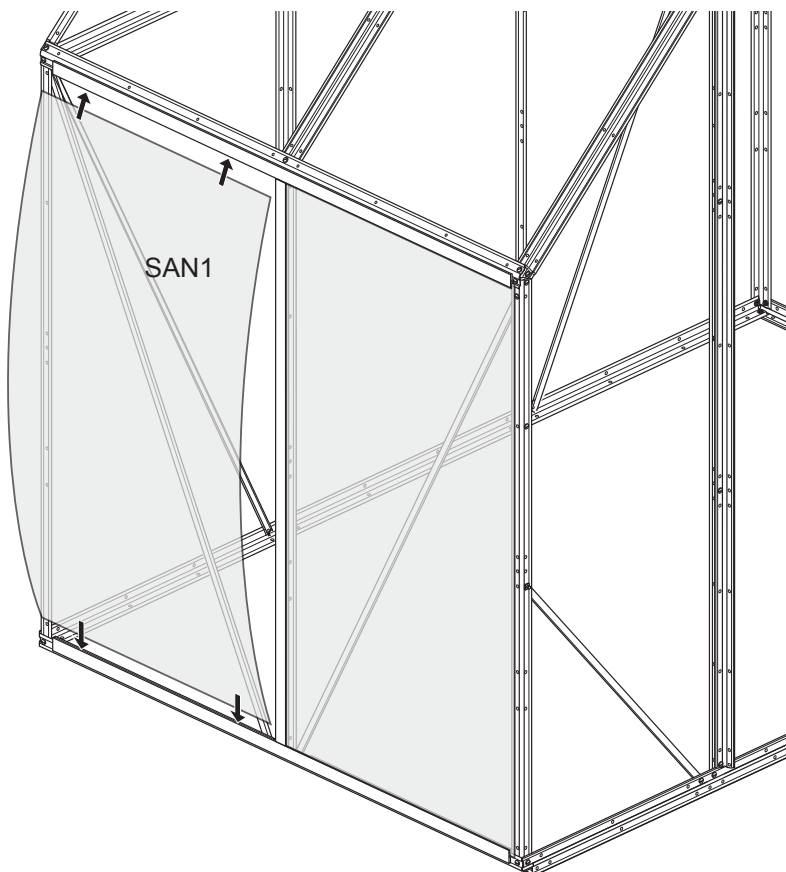

Take the next side panel SAN1 and position into the bottom trim, making sure it fits into the slot and not behind.

Slightly bend the panel out to fit into the slot at the top.

Slide the panel across so that the vertical edge slots into CT8A.

Run a table knife down to help to locate into the slot as you push in the panel.

Step 25 - Cladding the door end and side

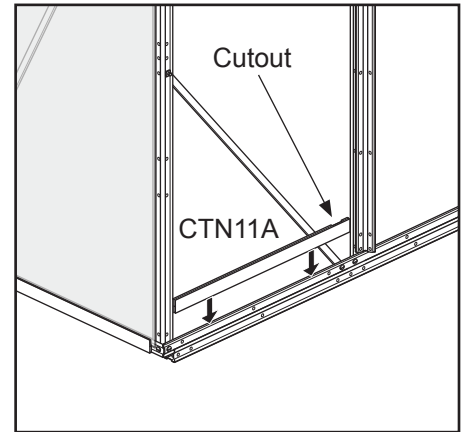
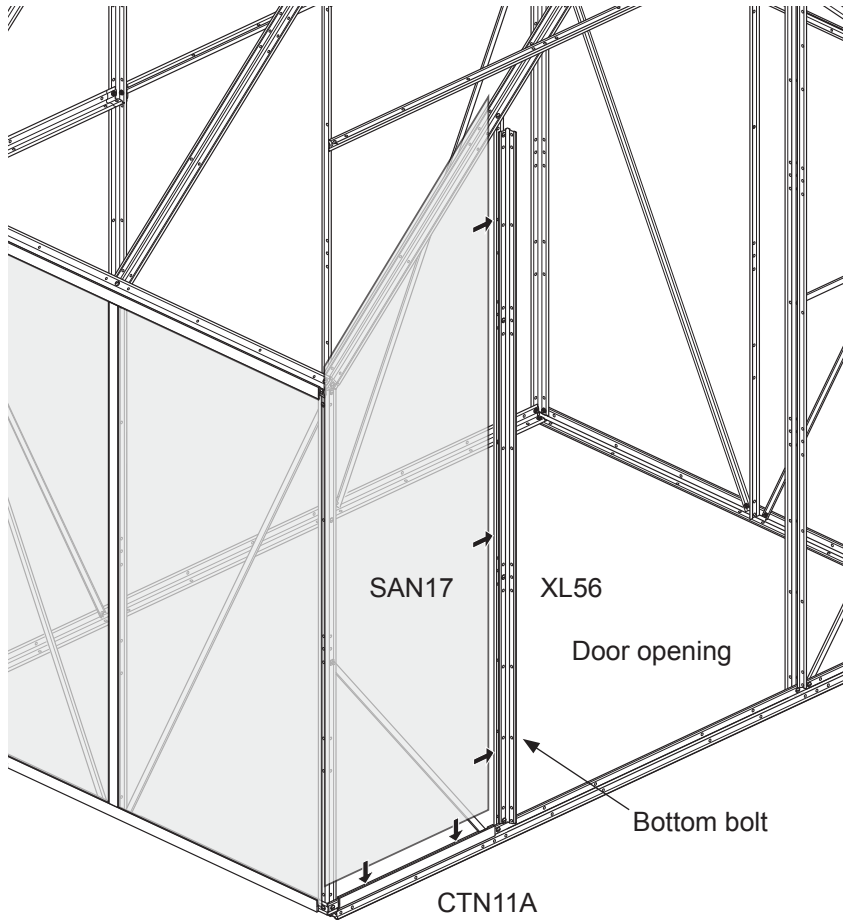

Fit a CTN11A to the bottom side of the door opening, make any cutouts in the lip as necessary.

Slide in panel SAN17 making it fit into the slot and not behind.

Slide the panel across so it slots between the door uprights of XL55S and XL56. Tighten the bolts to clamp in the panel.

Step 26 - Cladding the door end and side

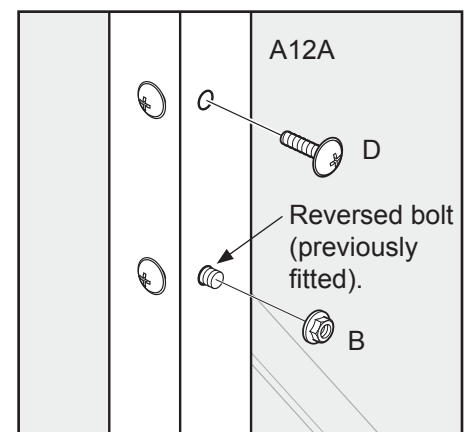
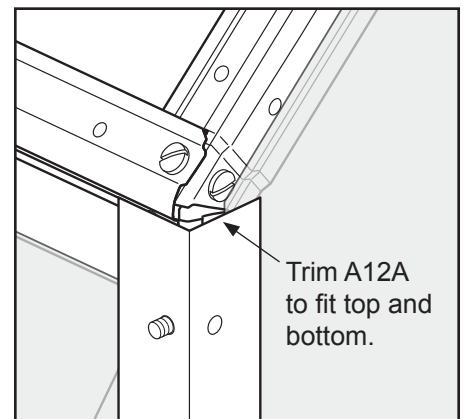
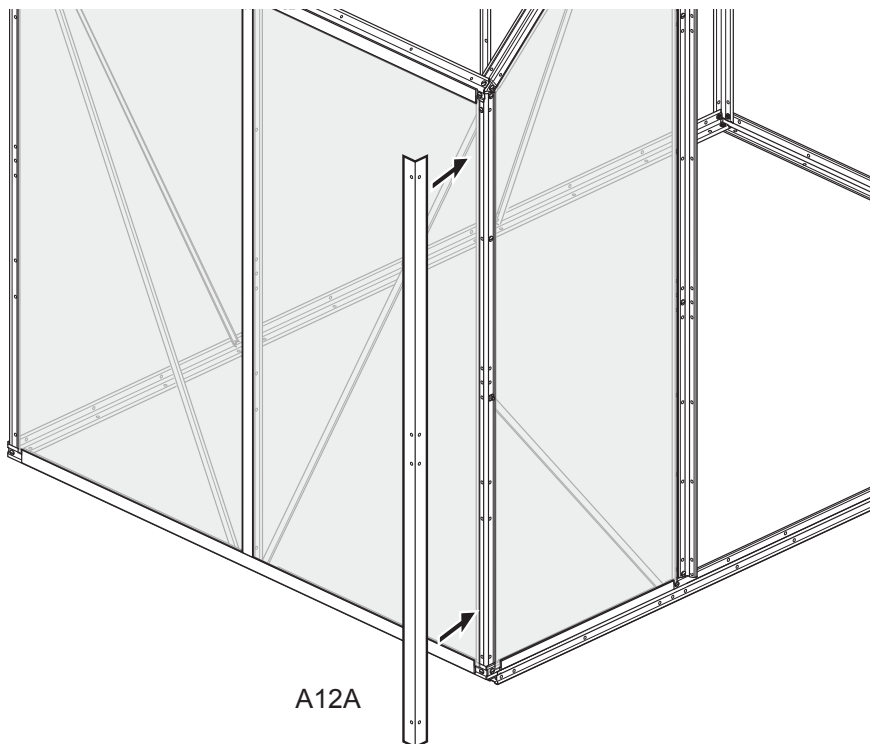

Fit the corner trims A12A using the self tapping screws D, note that the trim fits over **both** reversed bolts, cut to length top and bottom.

Screw through the holes in the trim and into the framework, fit nuts B onto the bolts. Use 6 screws on both sides of the trim.

Step 27 - Cladding the window end and side

For illustrative purposes, the cladding on the door end and side has not been shown.

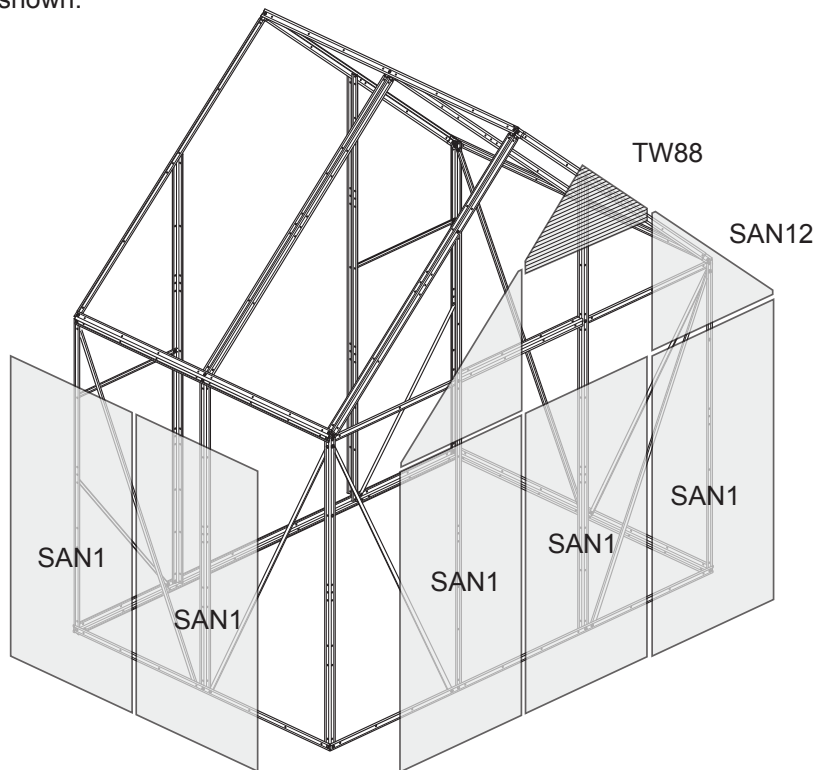

Use the same procedure to cover the window end.

This frame is shown viewed from the window end.

Use the clear SAN panels on the sides, they have clear film on both sides which should be removed before fitting.

The 2 top end panels are covered using Twinwall (TW) panels.

Step 28 - Cladding the window end and side

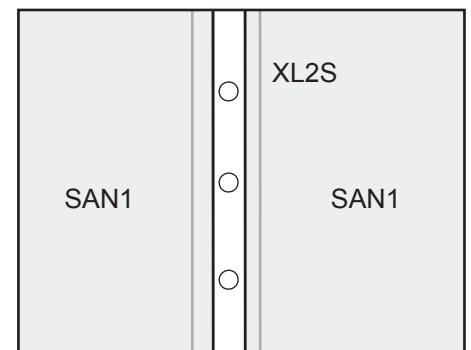
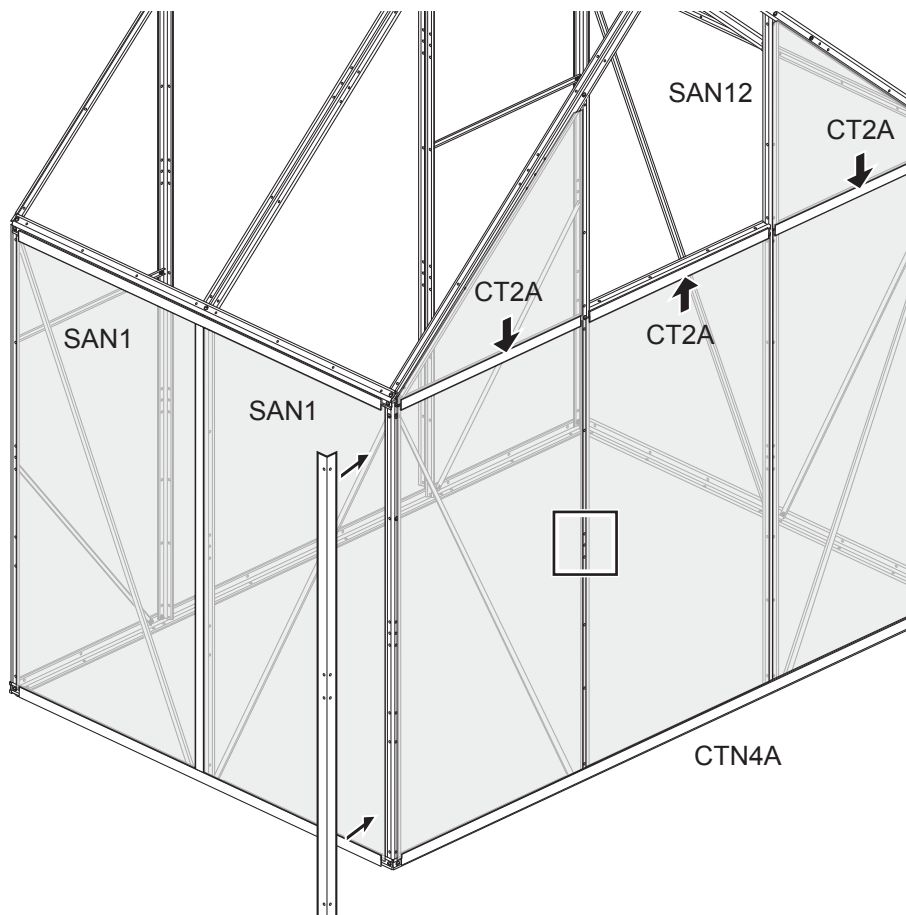

Complete the sides using SAN1 as in the door end.

The SAN1 on the end are held in place with CTN4A trim at the bottom, cutout as required. At the top they are held in position with 3 x CT2A, the middle fits over XL11WD from the bottom and the 2 outer ones fit from the top, trim back CT2A at the eaves to fit.

When the SAN1 are fitted side by side make sure the holes are clear in the frame XL2S.

Secure the panels at the corners using A12A trims as in Step 26.

Step 29 - Cladding the window end and side

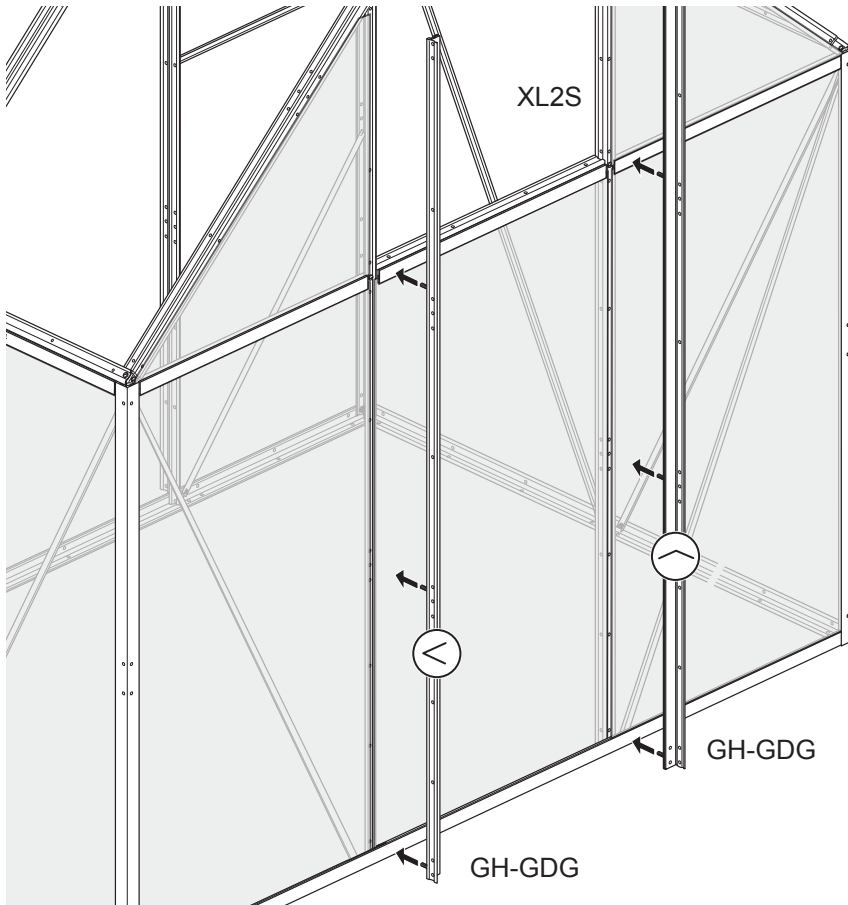

Using the 2 GH-GDG assemblies, left and right, locate the 3 bolts already assembled into the holes in XL2S, and between the bottom panels SAN1, the bottom bolt should fit into the second hole up in XL2S secure in position using nuts B. Make sure that they are the right way up (each one is marked top), this will then clamp the panels in position. Should the holes not match up use the supplied 4mm drill to clear out the holes.

Step 30 - Cladding the window end and side

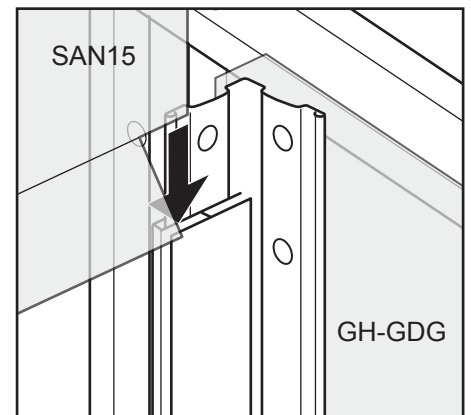
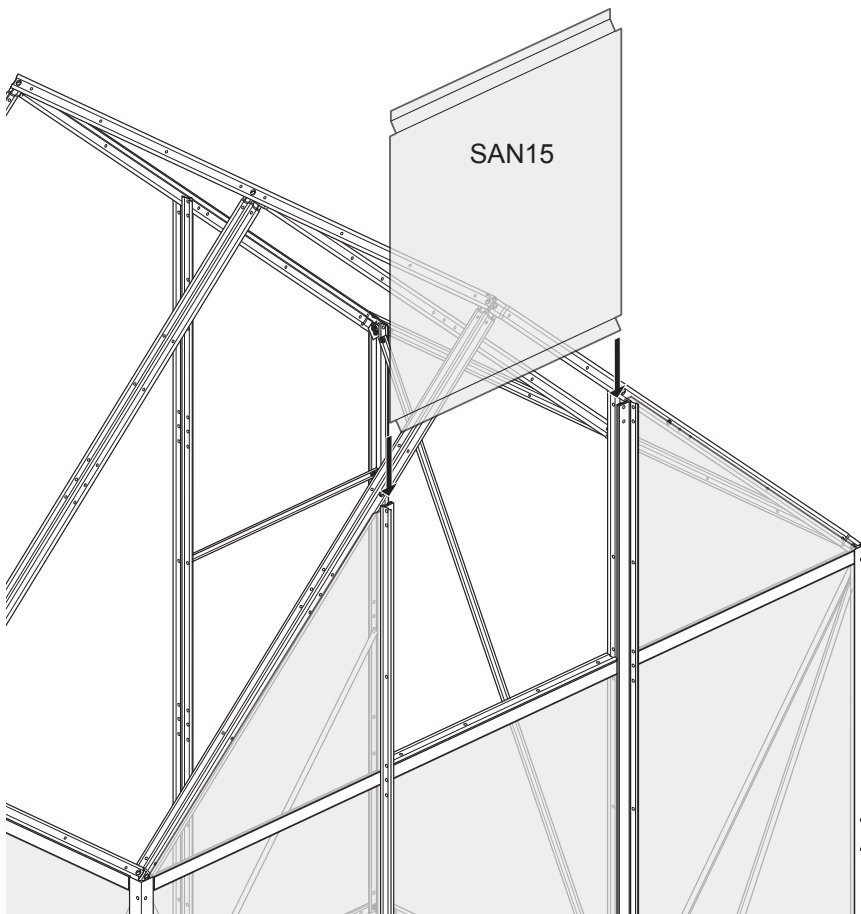

Slide SAN15 window panel down into the green trims on both GH-GDG from the top. The double bent edge of the panel should be at the top and facing inwards. Should the window panel be loose, tweak the sides of SAN15 for a tighter fit, see page 30 for details.

Step 31 - Cladding the window end and side

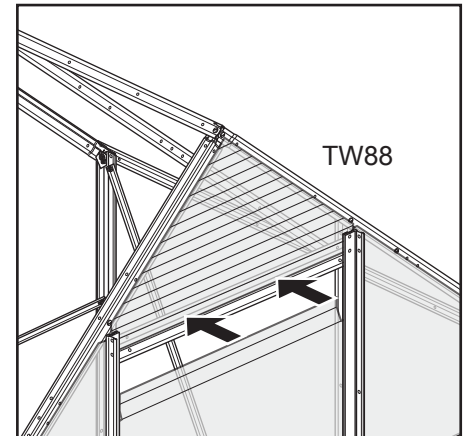
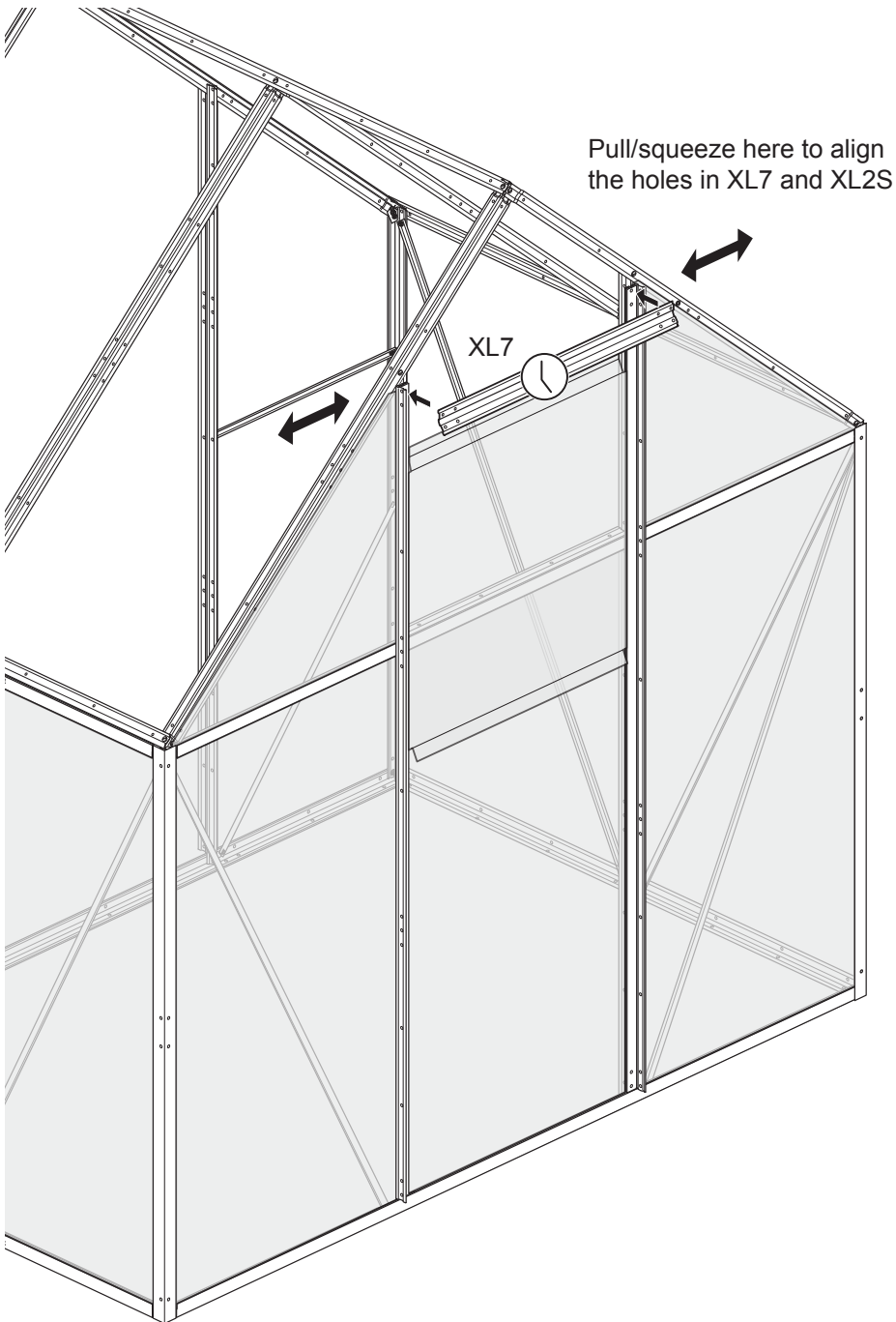

Fit XL7 to the second hole down of XL2S going through GH-GDG.

Use the top 2 holes of XL7 and the long bolts C and nuts B.

Place TW88 in position so it fits over XL7, pierce in 2 positions and secure to XL7 with 2 bolts C and nuts B.

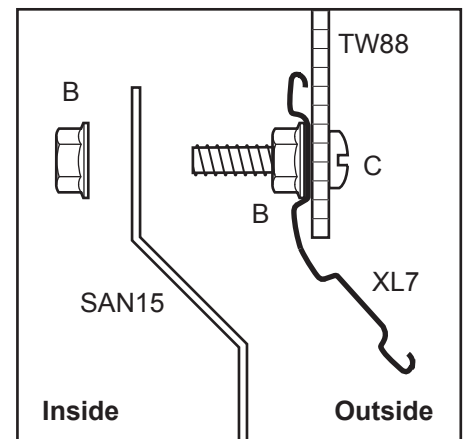

To add a more secure/tight closed position, drill through the SAN15 window inline with the 2 bolts.

The panel can then be fitted over these bolts and secured with nuts.

This is advised for stormy weather.

Step 32 - Cladding the roof

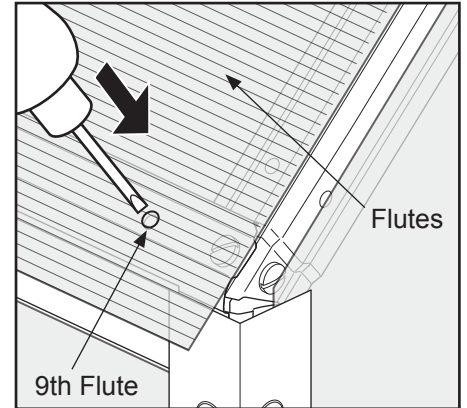
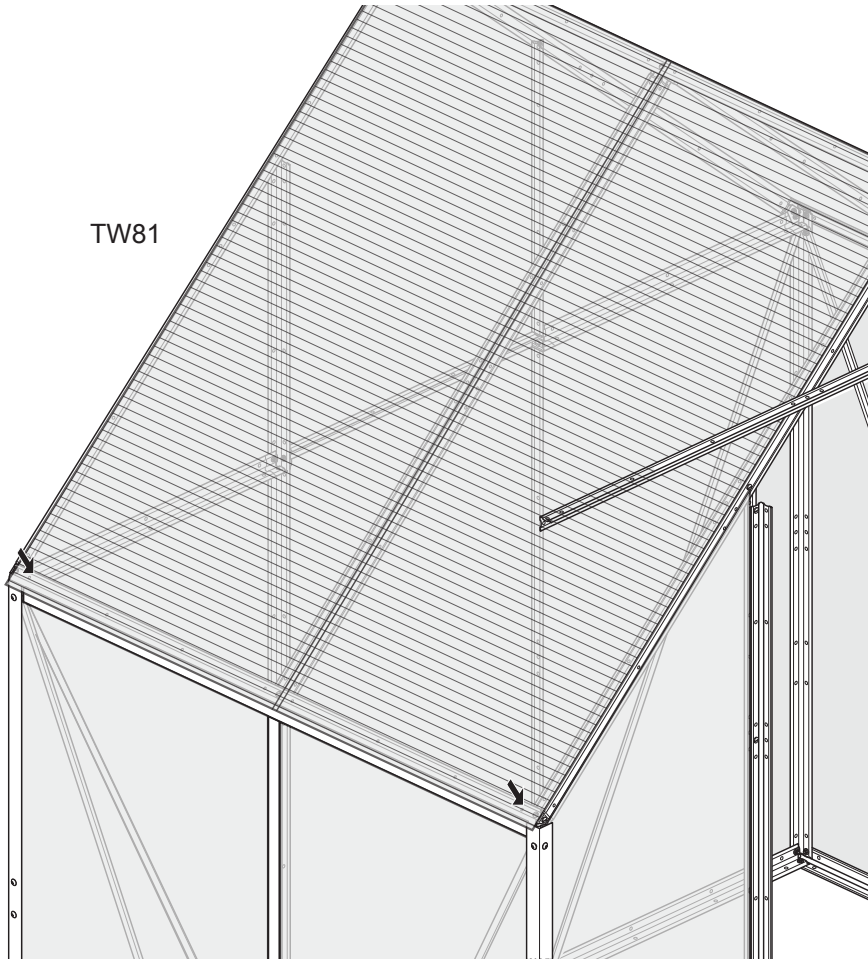

To fit the roof panel TW81, unfold and position the panel onto the roof with the flutes horizontally, the fold in the panel should line up with the centre roof bar XL1S.

Square the frame to the panels along the ridge and sides. Note that there should be an overhang at the eaves.

At the 2 bottom corners pierce the panel and fix in position with 2 screws D they should be about 9 flutes up from the bottom.

We recommend a bradawl or some sharp implement to pierce the twinwall, a drill will leave swarf in the flutes.

Step 33 - Cladding the roof

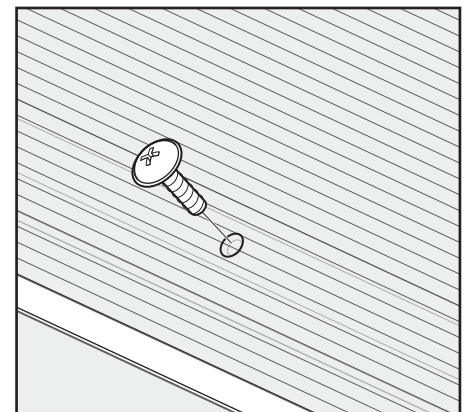
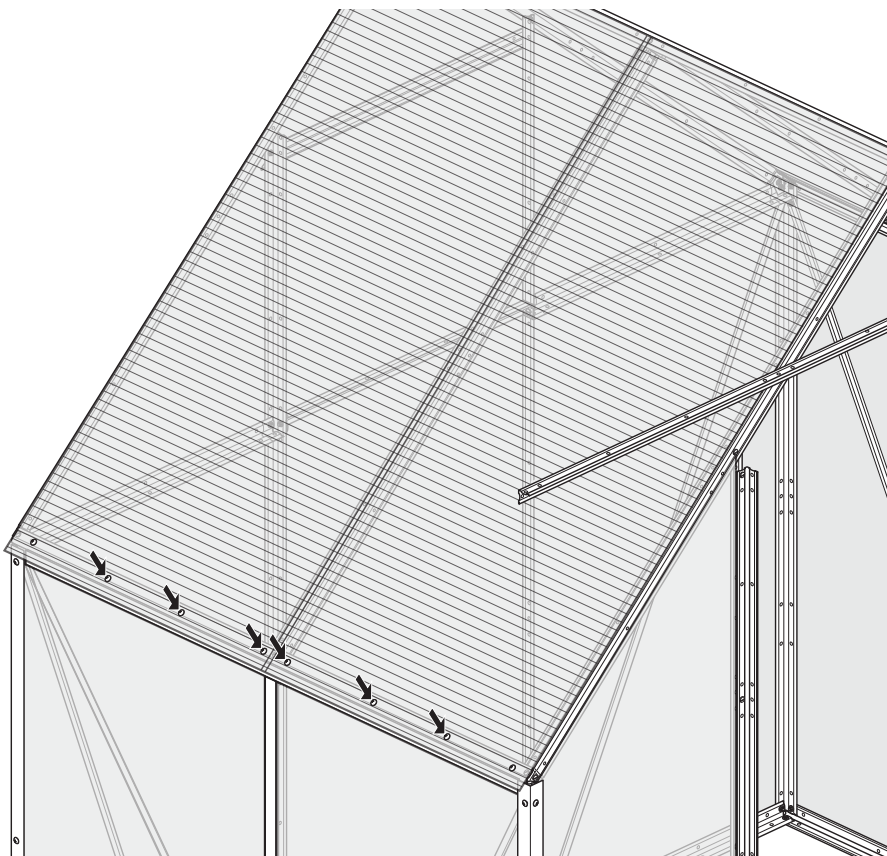

Make sure the panel is still square with the frame.

Complete the fixing of the panel, along the bottom **only** using the self tapping screws, repeat for the other roof panel.

Step 34 - Cladding the roof

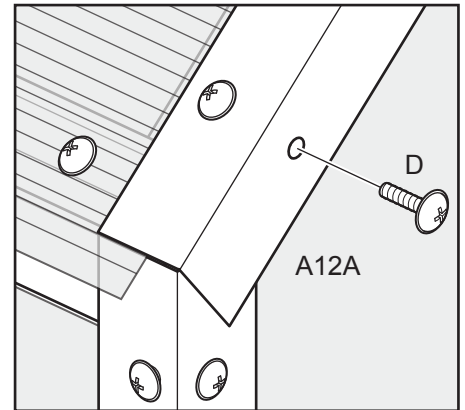
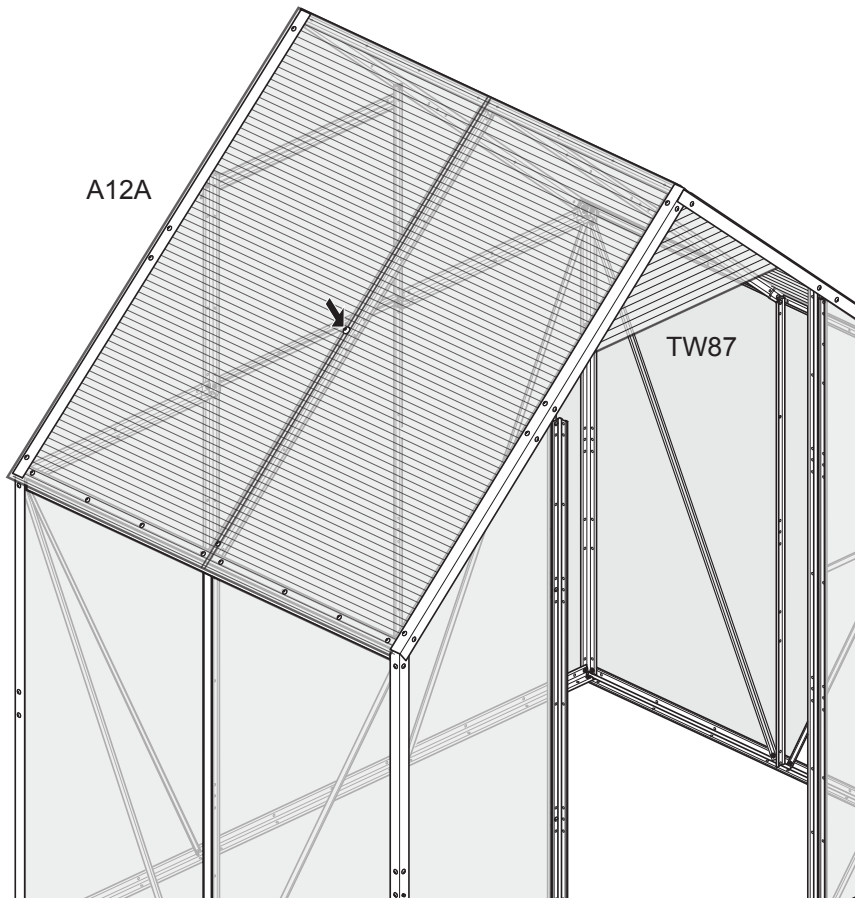

At the door end temporarily remove XL3.

Make sure that **BOTH** the roof panels are square with the frame.

Using a screw in the middle of each panel fix the 2 roof panels to the intermediate XL1S.

Position TW87 above the door,

Note: If you wish to stop water penetrating TW87 and TW88 seal the edges before fitting A12A trims.

Fit the plastic trims A12A to the ends of each section using the self tapping screws D.

Screw through the holes in the trim and into the framework.

Step 35 - Cladding the roof

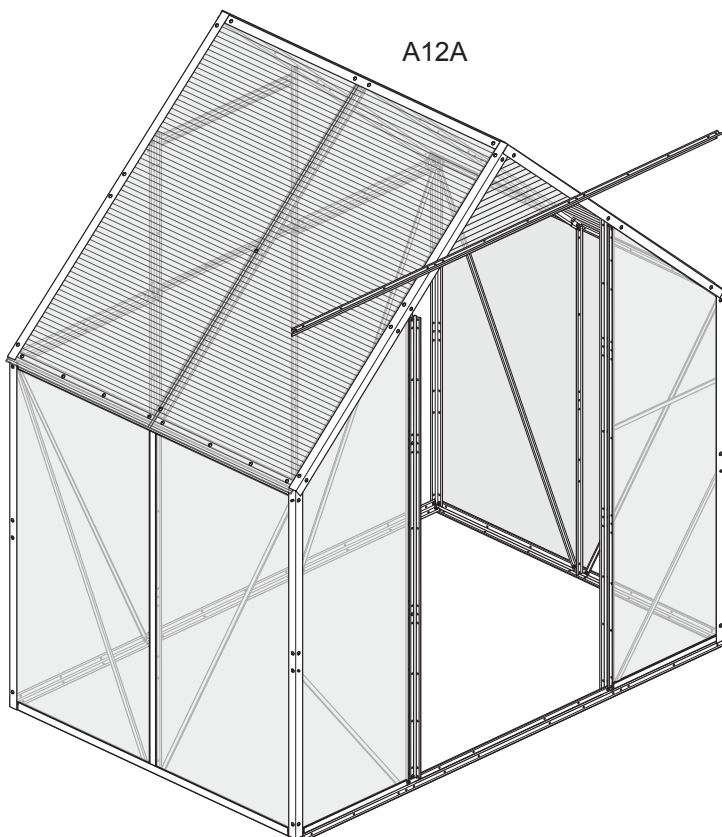

Fit trim A12A to the ridge using the self tapping screws trim to the required length.

When both sides are complete replace XL3 removed earlier, drill any new holes in the trim.

Step 36 - Door assembly

For illustrative purposes, the frame is shown being assembled flat on the ground.

This frame is shown viewed from the outside.

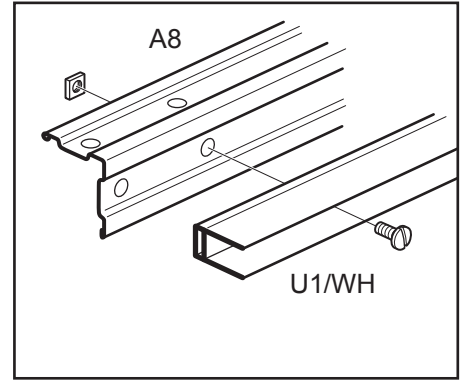
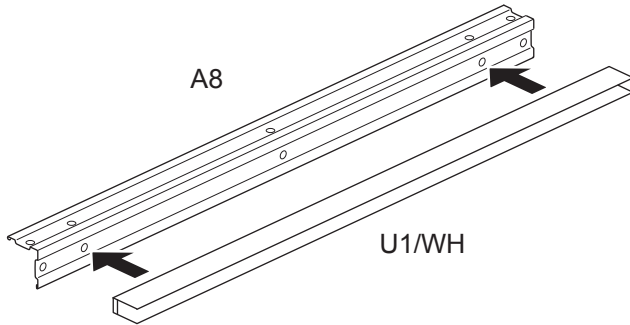

Bolt the door runner U1/WH to A8
Use the nuts and bolts that came with U1/WH.
You need to do this 4 times.

Step 37 - Door assembly

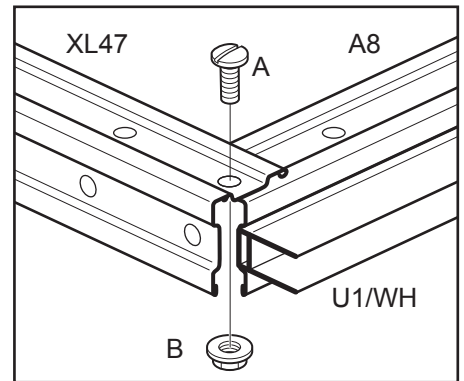
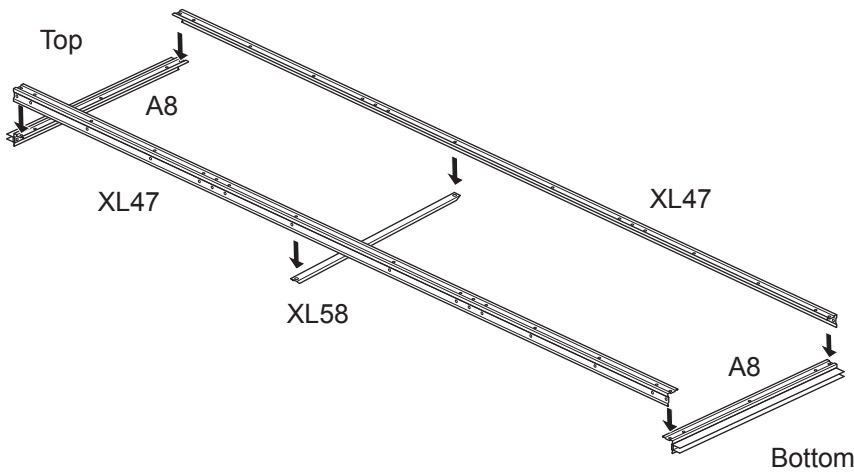

Bolt the door runner (U1/WH-A8) to the side rails XL47, use bolts A and nuts B.
Bolt XL58 between the 2 x XL47 side rails using bolts A and nuts B.

Step 38 - Door assembly

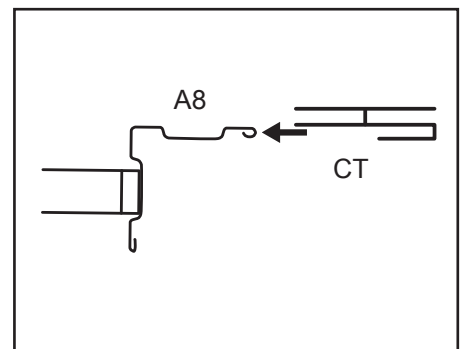
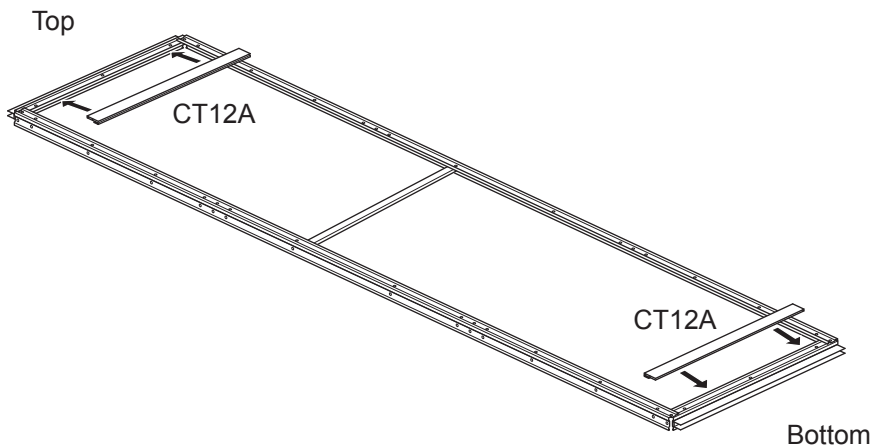

The door panels SAN18 are held in position with plastic trims CT12A at the top and bottom.
Push the lip of the trim onto the A8 angle.
Tighten all bolts.

Step 39 - Door assembly

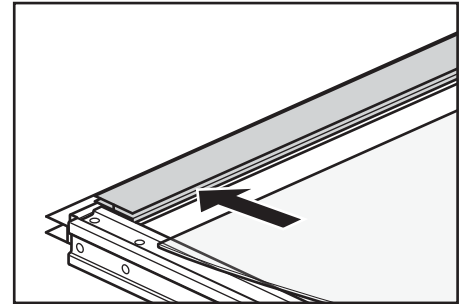
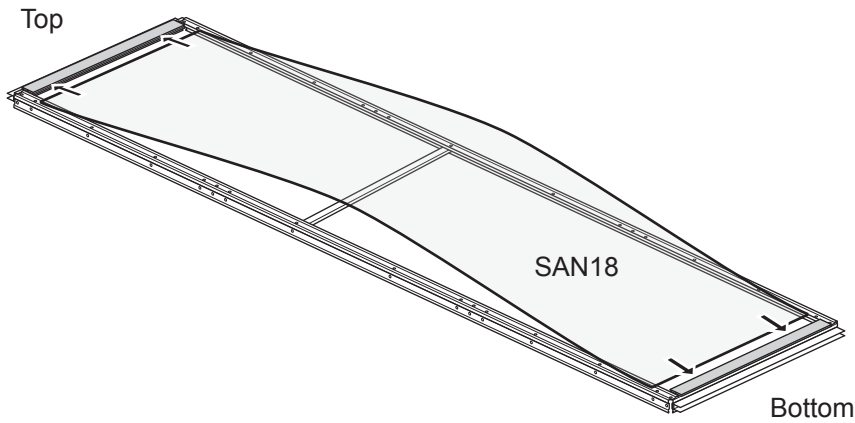

Take the door panel SAN18 and position into the bottom trim, making sure it fits into the slot. Slightly bend the panel out to fit into the slot at the top.

Step 40 - Door assembly

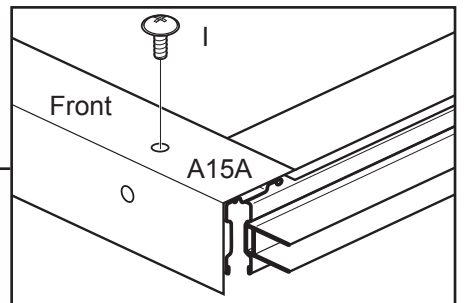
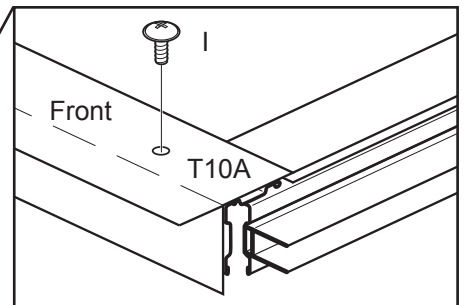
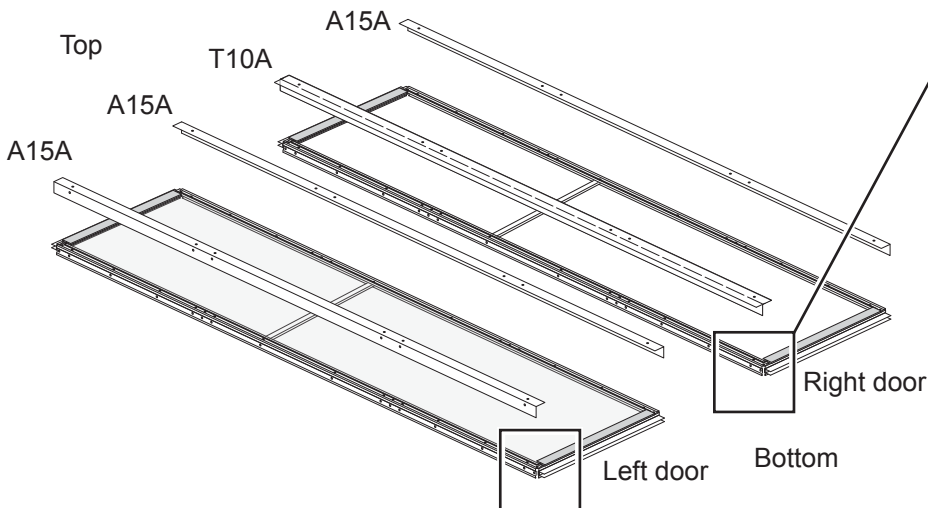

Fit the plastic trims A15A and T10A using the 6 self tapping screws I. Align the holes in the trim with the

holes in XL47, screw only through the **front** holes in the trim and into the framework.

Step 41 - Door handle

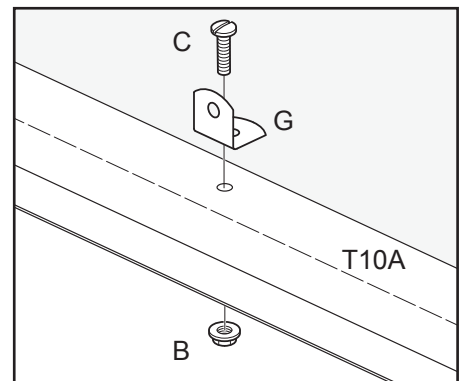
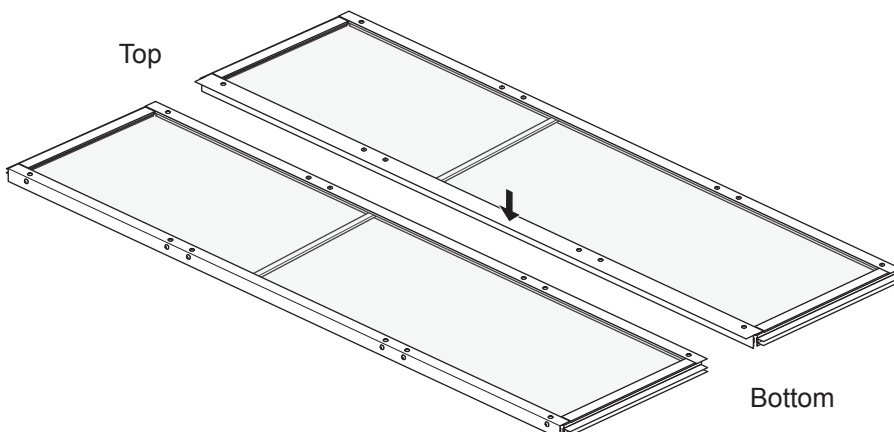

Fit a bracket to the front of the right door as shown.

Drill the plastic trim T10A on the 8th hole up and secure with bolt C and nut B.

Step 42 - Door installation

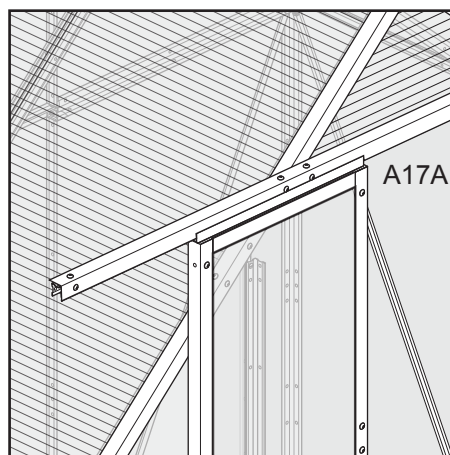
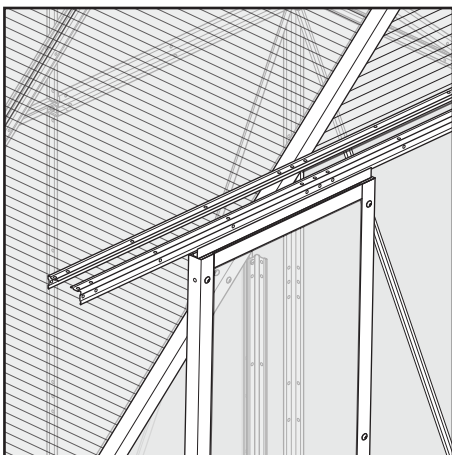
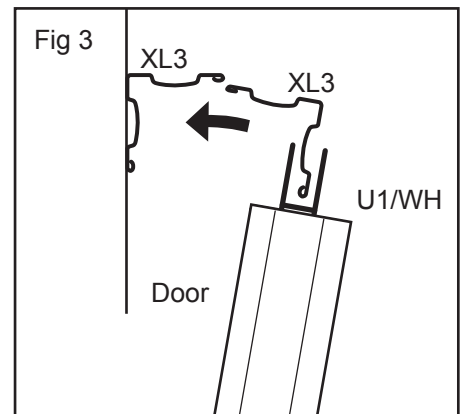
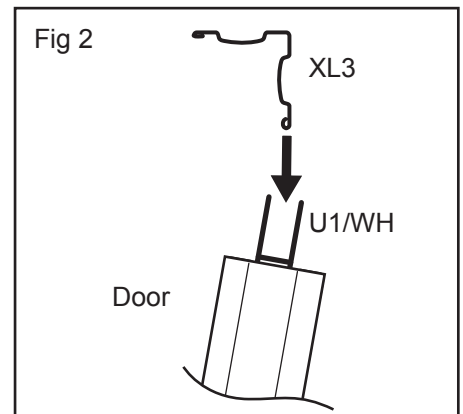
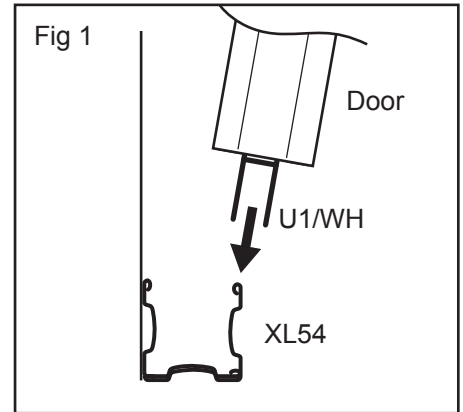
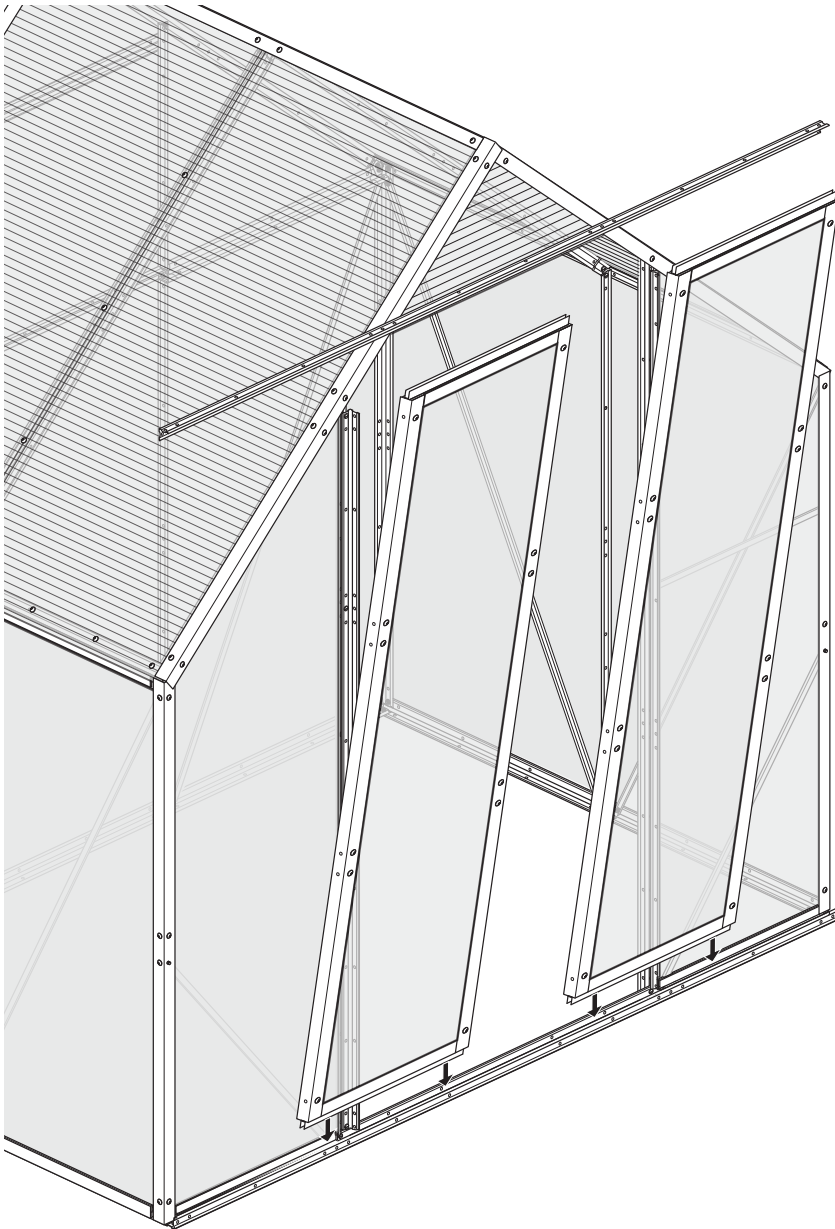

Take a door, at an angle locate U1/WH over the bottom XL54 (**fig. 1**), making sure that it fits under the bottom of upright XL56. It should also fit either side of the upright XL56 as this will act as a stop. Repeat for the second door.

Fit XL3 into the top runner U1/WH (**fig. 2**) and push in so it fits under the other XL3 already fitted (**fig. 3**), bolt in position with 4 bolts A and nuts B. Complete by fitting A17A trim to the top XL3 using selftapping screws D.

Step 43 - Completing the installation

Once your greenhouse is fully clad it is essential that the following steps are carried out. From the inside drill through the centre hole of XL1S and into trim CT8A then fit long bolt from the outside through the hole and secure with a nut.

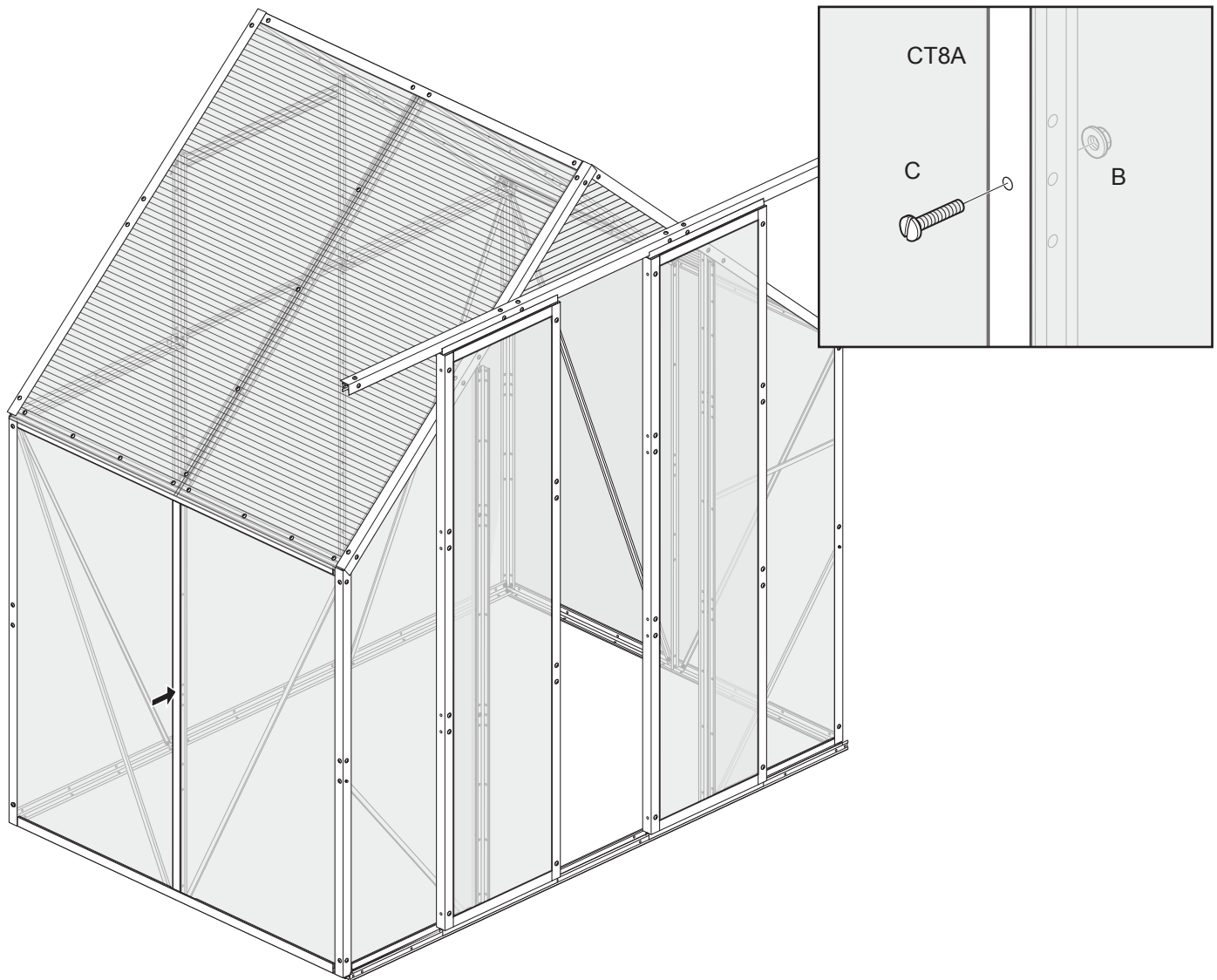

Your Greenhouse must now be fixed down using the holes around the base, use fixings accordingly to suit your base, see the groundworks section on page 6.

On completion tighten all nuts and bolts. It is advised that periodically or after storms/gales you check all nuts, bolts and screws, and tighten where necessary.

Maintenance

It is advised that periodically or after storms/gales you check all nuts, bolts and screws, and tighten where necessary.

Use warm soapy water and a soft cloth to clean the plastic panels, **DO NOT** use Cool Glass or similar products on the plastic panels.

DO NOT spray insecticides on the plastic panels.

Troubleshooting

If the doors do not slide.

1. Check to see if A14A or A15A side trim is not fouling the bottom runner, if so trim the bottom of A14A or A15A.
2. Make sure U1/WH door runner is sitting astride top edge of XL54.
3. RA brackets used as a door pull should be fitted on the lower part of the door.
4. Use silicone spray on the bottom runner XL54 for a smoother slide.

If door slides off runners.

Check XL61 or XL56 is fitted proud on the outside of the doorway and doors are running astride the angles, these angles act as door stop.

If door falls out.

Check XL3 that is used as the top runner, is fitted **under** the first XL3. This will close the gap making a tighter fit for your door.

If side panels fall out.

1. Check the long bolts have been fitted through CT8 trim on both sides.
2. SAN17 panels are trapped between XL55 and XL56 and bolts have been tightened.

If sliding window does not stay up.

Should the window panel be loose try to tweek the edges of the panel with a pair of pliers, this will create a small step to fit tightly into the trim. Do this as many times as required.

Should you still have problems drill through each side and fix in a long bolt, use this to help tension the window.

Should you wish to add a more secure/tight closed position, you are advised to drill through one of the holes in XL7 (top of window) and through SAN15. From the outside fit a long bolt C and nut B.

The panel can then be fitted over this bolt and a nut fitted, This is advised for stormy weather.

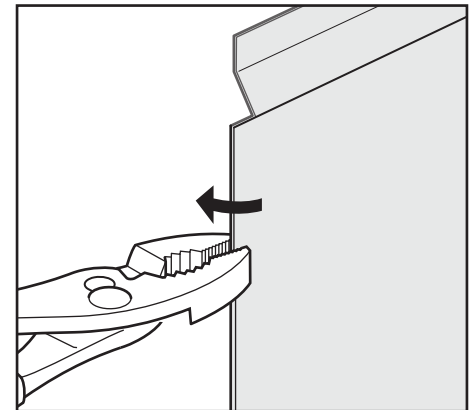

Further Information

Claims against the manufacturer will become invalid after the start of the assembly.

If you are not satisfied with your purchase, write or fax **020 3011 2040** to Customer Services within 10 days of receipt of goods requesting a pre paid returns envelop.

Under no circumstances return goods without contacting Customer Services.

Refunds will not be made unless goods are returned unused and complete and in original packaging.

Carriage charge is non refundable and any missing or damaged parts will be charged for.

In the unlikely event of a missing or broken part, it is essential that you advise us within the 10 day period.

These missing or damaged parts will only be sent to you free of charge on one occasion you are advised to get it right the first time.

Further requests will be charged for.

Your statutory rights are not affected.

Our policy is of continuous product improvement and we reserve the right to change specification without prior notice, therefore the latest model is supplied.



Norfolk Greenhouses

Chiswick Avenue Industrial Estate
Mildenhall
Suffolk
IP28 7AZ

Tel: 020 3011 2040

Email: info@norfolk-greenhouses.co.uk