



PRODUCT BROCHURE
2020

WHAT'S NEW

At Chapman we strive to continually improve everything we manufacture so that you get the best product. Here are just a few of the many improvements we've recently made.

CONTACT US

Chapman Machinery Ltd
Hele Barton, Week St. Mary,
Holsworthy, Devon, UK
EX22 6XR

Tel: +44 (0) 1288 308149

WWW.CHAPMAN.CO.UK

 /chapmanmachineryLtd

youtube.com/chapmanmachinery

DISCLAIMER

This literature is designed for worldwide circulation. Due to a policy of continuous improvement, we reserve the right to alter specifications and constructions without notice. As machines are exported to many different countries, general information, pictures and descriptions are provided. These should be taken as approximate and may include optional equipment that is not part of the standard specification. Please consult your local dealer or distributor for further information.



PC120 Paddock Cleaner

The all new Chapman PC120 Paddock Cleaner is the perfect machine for effortless paddock maintenance. Easily picks up leaves, dung and other debris towed behind a Quad, UTV or 4x4. Electric start & electric hopper are fitted as standard.

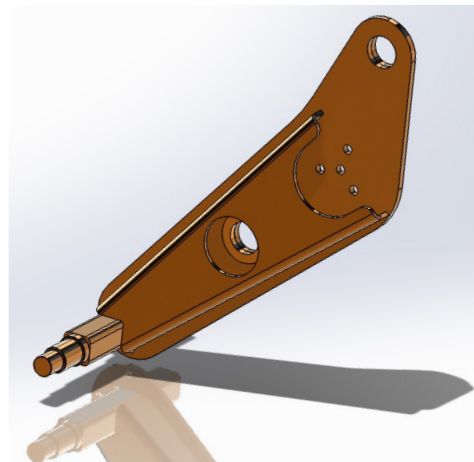

Improved FM Axles

The popular Flail Mower series now feature a small upgrade to the axles which have now been strengthened to higher tolerances. This also makes switching to the 'wheels trailing' set-up easier than ever.



TGF350 Game Feeder

The TGF350 replaces the tedious task of game feeding with bags. Simple electronic operation means feeding can be controlled from the cab easily, and adjustable spinner deflector plates can tailor the spread width of feed, or direct to one side.



New Rotary Blades

Our rotary mower series now features stronger heavy duty blades to give you the optimum cut with improved performance and better lift to cut thick or wet grass with ease.

PRODUCTS

04 OUR STORY

08



FM SERIES
FLAIL MOWER

12



RM120/150
ROTARY MOWER

14



PC120
Paddock
CLEANER

16



MG250
ARENA LEVELLER

18



TH200
TINE HARROW

20



W240
WEED WIPER

22



TF350
TRAILED LIVESTOCK
FEEDER

26



MF350
MOUNTED LIVESTOCK
FEEDER

28



TGF350
TRAILED GAME
FEEDER

30



BT500
BALE TRANSPORTER/
TRAILER

32



QT200
ROAD TRAILER

34



ST150
ATV TRAILER

OUR STORY

Chapman Machinery Ltd is an innovative design and manufacturing company producing products for equestrian, agricultural and estate management sectors.

From humble beginnings manufacturing ATV Trailers, the company has grown rapidly through continual investment in people, plant and machinery to produce a range of quality labour saving machinery.

We offer a two year warranty for peace of mind on all of our machines and work in partnership with local distributors to ensure our customers have a local point of contact for advice on getting the best out of your machine and to source any spares that may be required.

With dedicated design, manufacturing and assembly premises in the South West of England, Chapman Machinery Ltd proudly manufacture our products in Great Britain. Over 40% of our production is exported to Europe, using local distribution partners.

Our Aim

At Chapman Machinery Ltd our focus is on making a quality product that is easy to use.

Quality design and the utilisation of advanced manufacturing techniques ensure our products are of exceptional quality, yet represent great value. We aim to be a global manufacturer and are building towards this goal by ensuring we create great products of exceptional quality, backed by outstanding support.

James Chapman

Director



WHY CHOOSE CHAPMAN?

Founded in 2010, we're one of the newer manufacturers in the machinery world. We often get asked by potential customers why we think our machinery is better than the existing providers, so here are a few reasons why we're great to deal with.



MANUFACTURED IN GREAT BRITAIN

We genuinely believe the only way to truly keep quality consistent is to have your design, manufacturing, sales and spares all on one site, which we do.

This means we know our machinery, and can easily supply spares from our inventory at our base in Holsworthy, Devon, UK.



2 YEAR WARRANTY

To get to number one we strive to produce high quality machinery, at a competitive price point, and stand by it with an industry leading two year warranty. You will always find cheaper machinery on offer, but we are confident you won't find better whole-life value.

We are in this for the long-run, and as such try to ensure we're selling you the right piece of kit for what you're trying to achieve. We pride ourselves on honest, straightforward advice on any sales queries.



WE INNOVATE

We proudly design our machinery to be a genuine 'Chapman' product. Every machine carries the company founder, James Chapman's surname, and as such has to be to a high standard.

We design each and every one of our machines to feature innovative, unique features, to give you the best user experience. We don't simply copy what is already out there, as this is a poor basis to build a quality brand on.



BRITISH MANUFACTURING AT ITS BEST

Every machine we produce is designed, fabricated and built on site. From raw steel through to a finished product we manage the process, giving us control over the quality. We proudly manufacture each and every product right here in the UK.

DESIGN

Every machine starts its journey with a full CAD design. This allows every part to be checked for form, fit and function before fabrication.

New designs are built, tested and approved before the design progresses to full production. At this stage, engine powered equipment is independently tested by Honda so that each product is fully warranty approved.

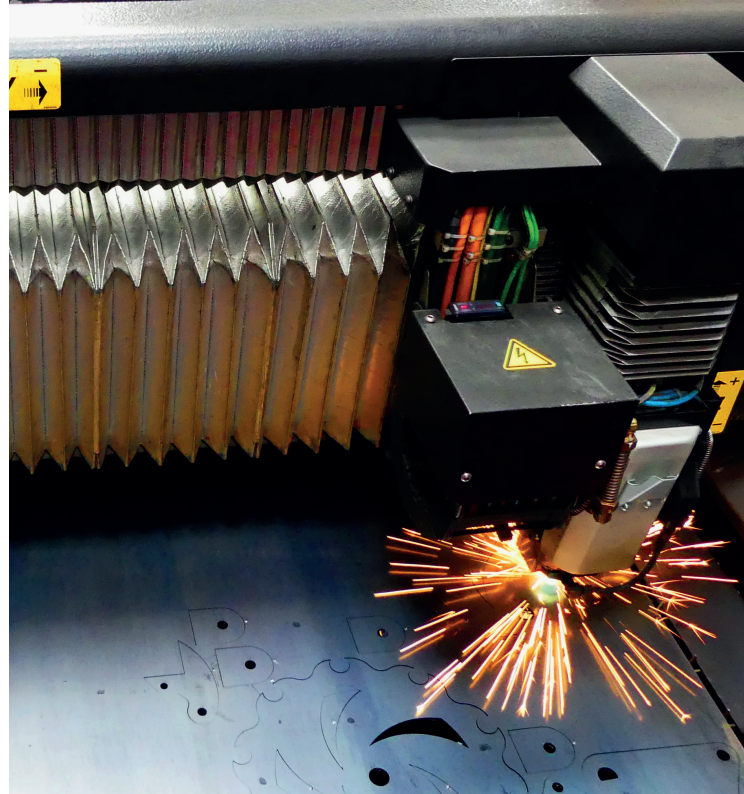

FINISH

All machines are shot blasted and powder coated on site. Shot blasting cleans the steelwork and provides a key for the paint to adhere strongly to, giving an even, glossy and hard-wearing finish.

We powder coat the machines in our trademark orange and black paint. We use powder coating as it is a very hard wearing finish and is considerably more environmentally friendly than traditional wet spray painting.

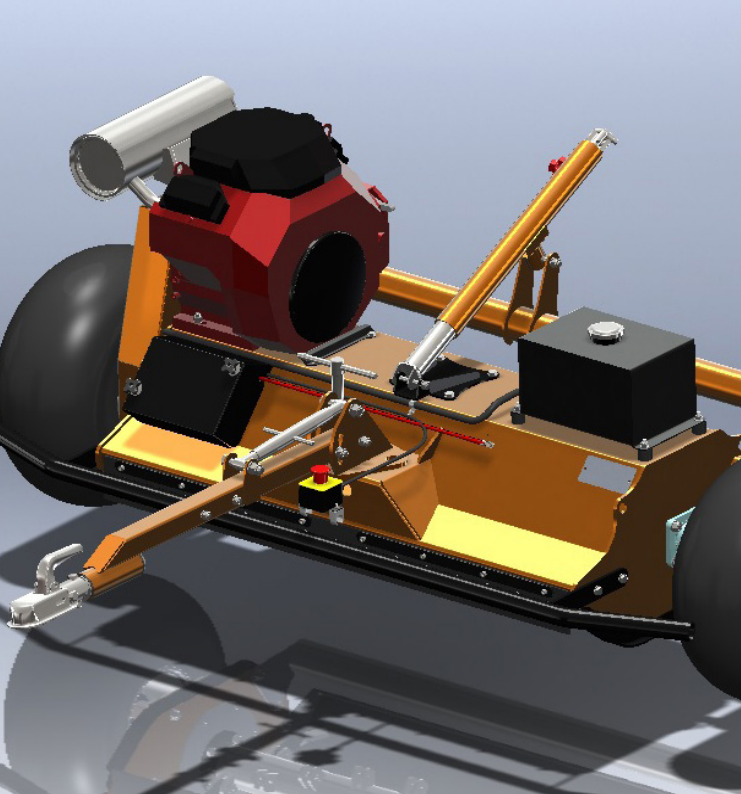

FABRICATE

Once the design is finished, tested and approved, the steel is laser cut and folded to the correct forms all in-house. We use laser profiling as it is the most accurate form of cutting large volumes of steel, ensuring precision and conformity of every product produced.

Critical parts such as bushes and bearings are CNC machined to the highest tolerances for accuracy.

All of the components are brought together and fully fabricated on site. This ensures all frames and components are made to measure before progressing for finishing.



FM SERIES FLAIL MOWER



Model shown FM120



Designed for the full range of topping and mowing tasks, from thick dense rushes to fine topping of parkland, the FM series Flail Mowers can tackle anything thrown at them. Extremely robust build with fine attention to detail ensures these mowers withstand years of use. Available in 1.2m (4') and 1.5m (5') cut widths.

The FM Series Flail Mowers feature a robust steel flail rotor, balanced to exacting tolerances for smooth operation, operating in a horizontal plane. This allows the cutting flails to fold back if an obstruction is encountered, to prevent damage to the machine.

Powered by a 21/23hp V-twin Honda engine, with integrated electric start, to give plenty of cutting power when needed, but in an easy to start and use package. Large flotation tyres can be set to run beside the cutting deck - for ease of towing and attachment - or behind the cutting deck - to enable cutting close to fences and hedges.

Simple height adjustment for ease of use and an automatic belt tensioning system with robust B Section drive belts for low-maintenance ownership, complete the package.



Wheels trailing the machine
(to enable cutting close to hedges and fences).



TECHNICAL FEATURES

- Powerful 21/23hp Honda engine with 3 year warranty
- Heavy duty construction throughout the machine
- Easy cutting height adjustment
- Unique double helix flail rotor, precision balanced for smooth operation
- Large diameter tyres for smooth travel over uneven arenas
- Automatic belt tensioning system for low maintenance
- Drawbar can be offset left and right
- Range of options to cater for specific requirements

OPTIONS



Front Breaker Bar

Ensures tall materials (e.g reeds or bracken) feed evenly into the rotor for consistent cutting performance



Chop Control Cutter Bar

Adjustable cutting bar within the deck to increase mulching and speed breakdown of cut material



Twin Axle

Twin wheels on bogie axles for smooth towing over the roughest terrain



Engine Centre Mounting

Engine is centrally mounted for 50/50 weight distribution giving greatly improved stability on steep ground



Hammer Flails

Forged and hardened hammer flails for cutting brush or to give the cleanest cut and finish on grass

SPEC	FM120	FM150
Cutting Width	1.25m	1.5m
Weight	305kg	325kg
Number Flails (Standard)	44	52
Number Flails (Hammer)	22	26
Cutting Height (mm)	25-225	
Rotor RPM	2400	
Rotor Balancing Grade	G6.3 Dynamic Balance	
Engine	21/23hp Honda V Twin	
Tyre Size	22x11x8"	
Fuel Tank Capacity (litres)	10	
Drive belt size	2 x Bx41	

UNIQUE SPIRAL ROTOR DESIGN

Our innovative rotor design incorporates a solid 40mm diameter drive shaft right through the centre of the rotor with a structural grade 90mm diameter outer tube, onto which the flail lugs are welded in a spiral pattern. This unique design transfers cutting power more efficiently from the engine to the cutting heads, giving a cleaner cut and better performance in tough situations.

Furthermore the rotor incorporates dedicated bearing guards designed to prevent string and wire damaging the bearings.

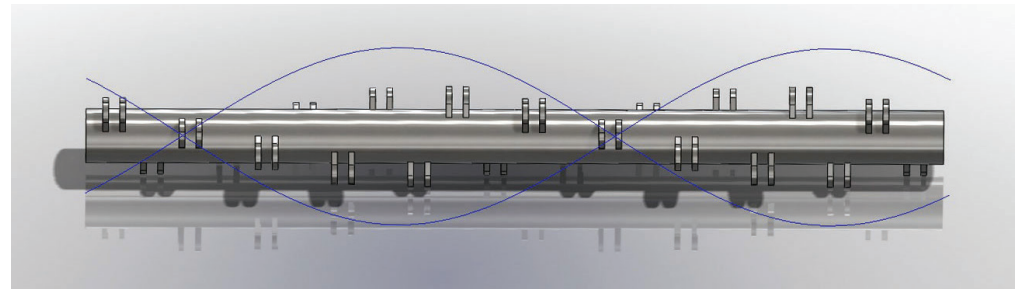

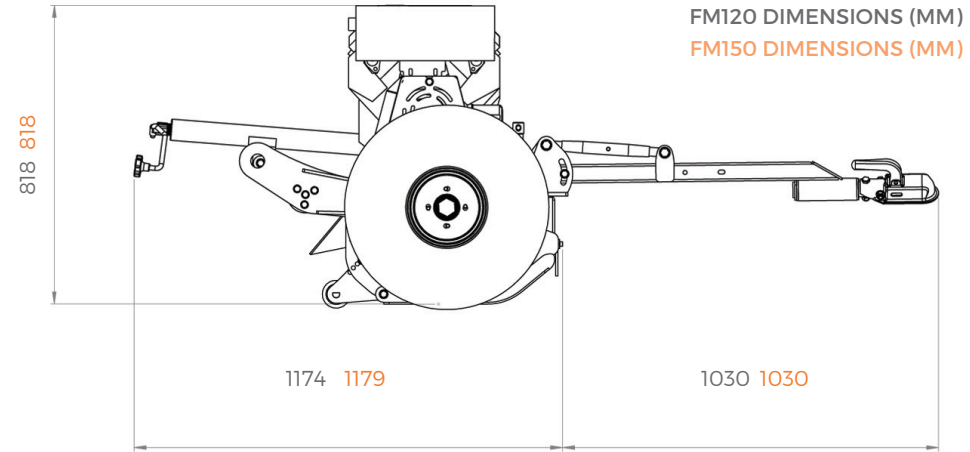
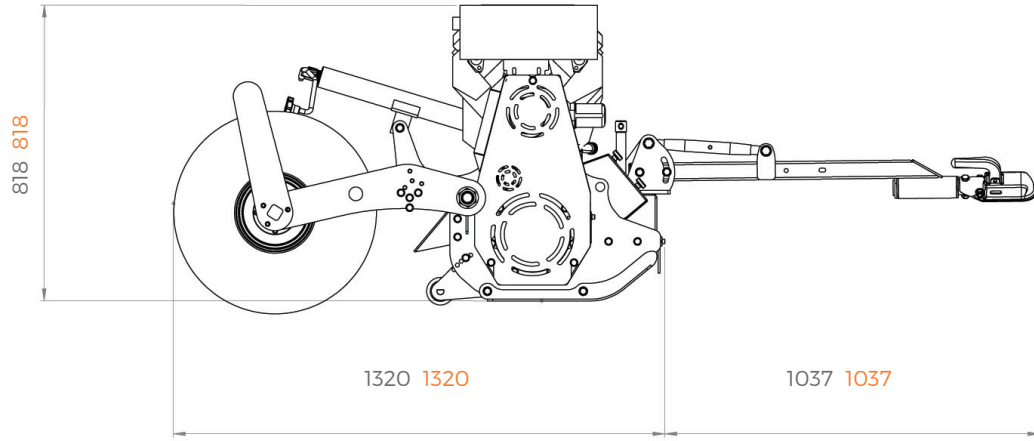

FM120 DIMENSIONS (MM)
FM150 DIMENSIONS (MM)

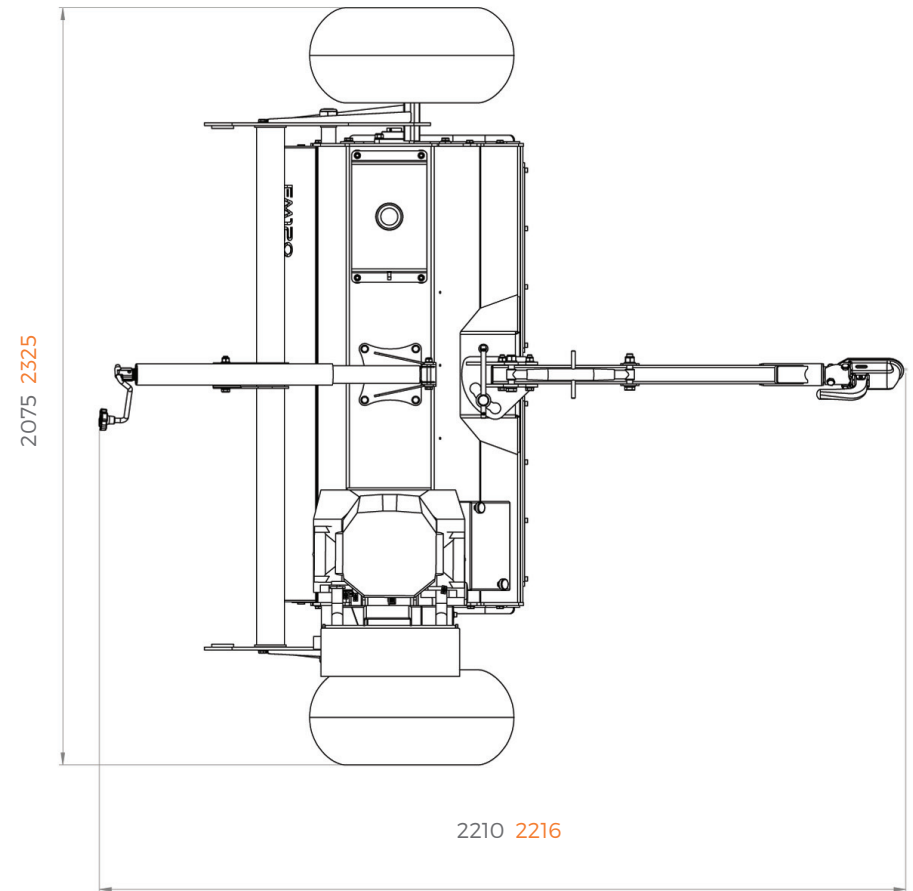
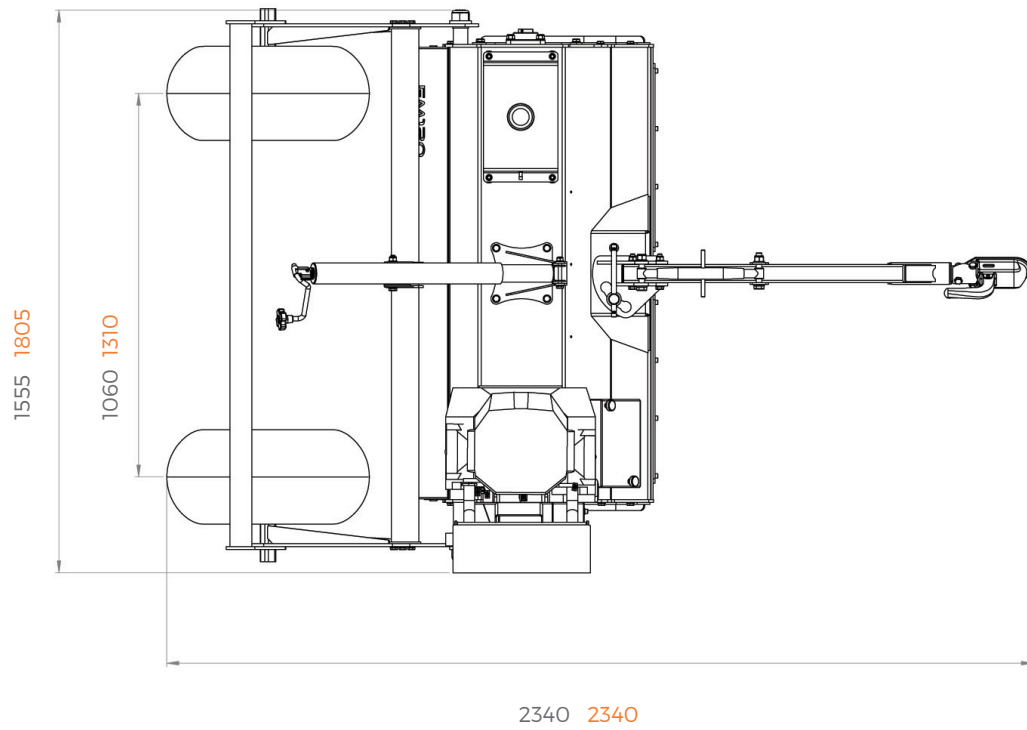

RM120 / 150 ROTARY MOWER



Model shown RM120



Designed for general topping and paddock maintenance duties, the RM Series Rotary Mowers give a great finish on parkland and large gardens, with the added benefit of a robust build which can handle rough fields and paddocks easily.

The RM Series now feature three new improved, heavy duty cutting blades to give you the optimum cut along with improved performance. Specifically designed to allow for better 'lift' to cut thick or wet grass with ease.

Easy to use height adjustment makes mowing quick and easy, with the large 19x7x8" tyres rolling smoothly across any terrain. Available with a recoil start 13hp Honda GXV390 engine (electric start optional).

TECHNICAL FEATURES

- Easy cutting height adjustment
- Large diameter tyres for smooth travel over uneven arenas
- Simple belt tensioning system designed to extend belt life and reduce wear
- Drawbar can be offset left and right
- Single piece heavy duty blades
- Honda engine with easy-start decompression
- Simple controls – fully integrated choke, throttle and stop in one control
- Robust deck and build

OPTIONS



Electric Start

Easy electric start option available with battery and starter controls mounted on mower to prevent damage.

SPEC	RM120	RM150
Cutting Width	1.2m	1.5m
Weight	175kg	205kg
Cutting Height	25-200mm	
Rotor RPM	2500	
No. of blades	3	
Engine Power	13hp Honda GXV390	
Tyre Size	19 x 7 x 8"	

RM120 DIMENSIONS (MM)
RM150 DIMENSIONS (MM)

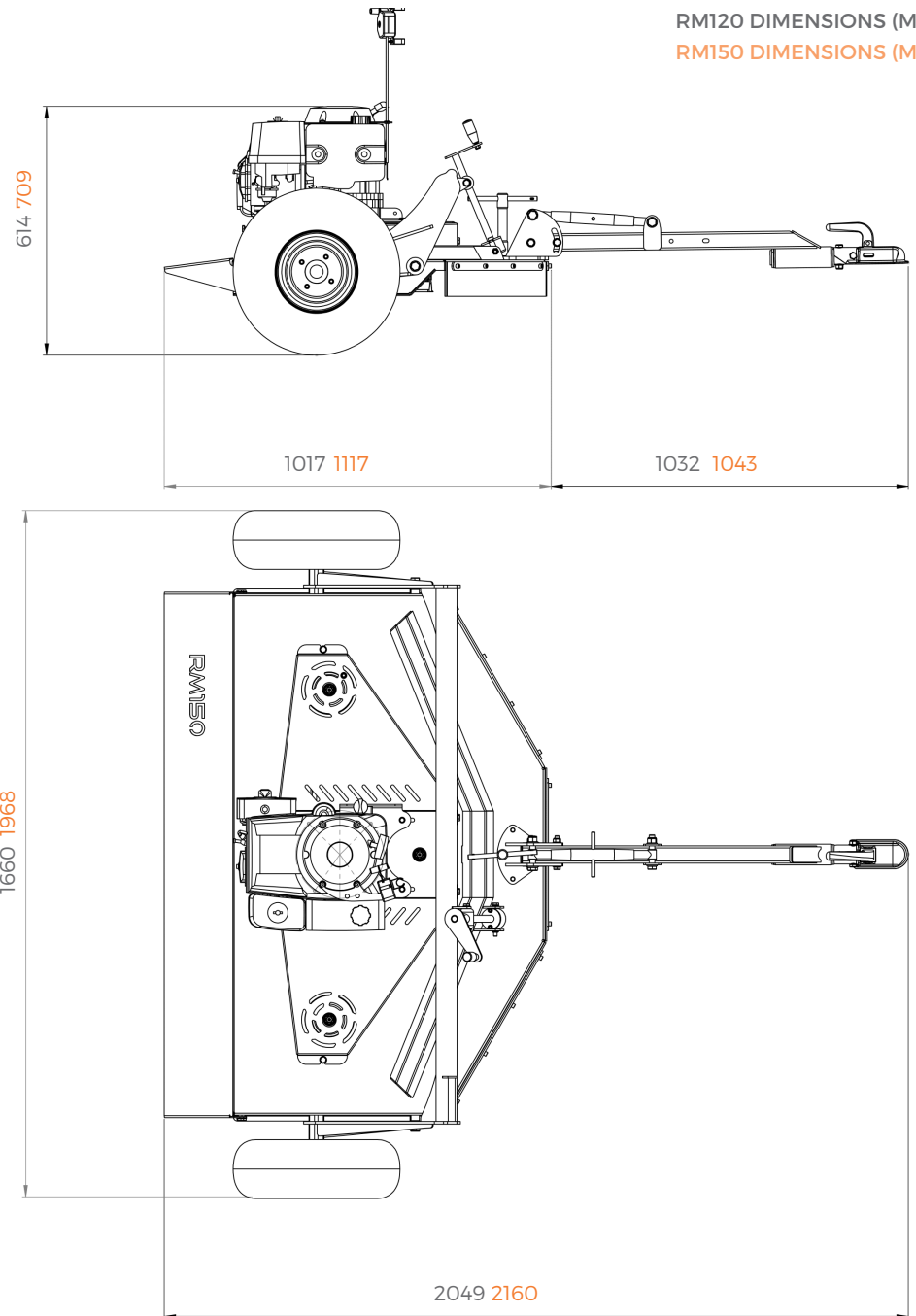

PC120 PADDOCK COLLECTOR



Electric Hopper
Emptying



The PC120 Paddock Cleaner is a 1.2m working width Paddock Sweeper, designed for effortless paddock maintenance. The PC120 is a self-powered towed unit for use behind almost any vehicle equipped with a 50mm ball or pin hitch. Sweeping up leaves, dung and other debris can be a tedious task by hand, the PC120 makes a strenuous maintenance task quick and simple, keeping your paddock clean and healthy.

The PC120 is powered by a reliable 6.5hp Honda GX200 Engine and centrifugal clutch system which engages 4 heavy duty brushes which pick up dung and other loose debris with ease. The paddock cleaner also comes with an adjustable Tine Bar as standard to help break up compacted dung for more stubborn paddocks.

The Electric Emptying Hopper comes with a remote tipping mechanism for ease of use from your ATV/UTV. This makes for effortless emptying of the large 550 litre hopper, removing the need for hand winching and locking mechanisms of similar competitor machines.

TECHNICAL FEATURES

- Robust deck and build with laser cut vents
- Remote electric empty hopper for ease of use
- Single axle for easy manoeuvrability
- IP69 Sealed Electrics
- 8 quality steel tines to help break up stubborn dung piles
- Heavy duty brushes for longevity
- Large diameter tyres for smooth travel over uneven arenas
- Tried and tested British manufactured swivel hitch

SPEC	PC120
Weight (Unladen)	300kg
Engine	6.5hp GX200 Honda with Electric Start
Hopper Size	550litre Hopper
Tyre Size	19 x 7 x 8"
Working Width	1.2m (4ft)



DIMENSIONS (MM)

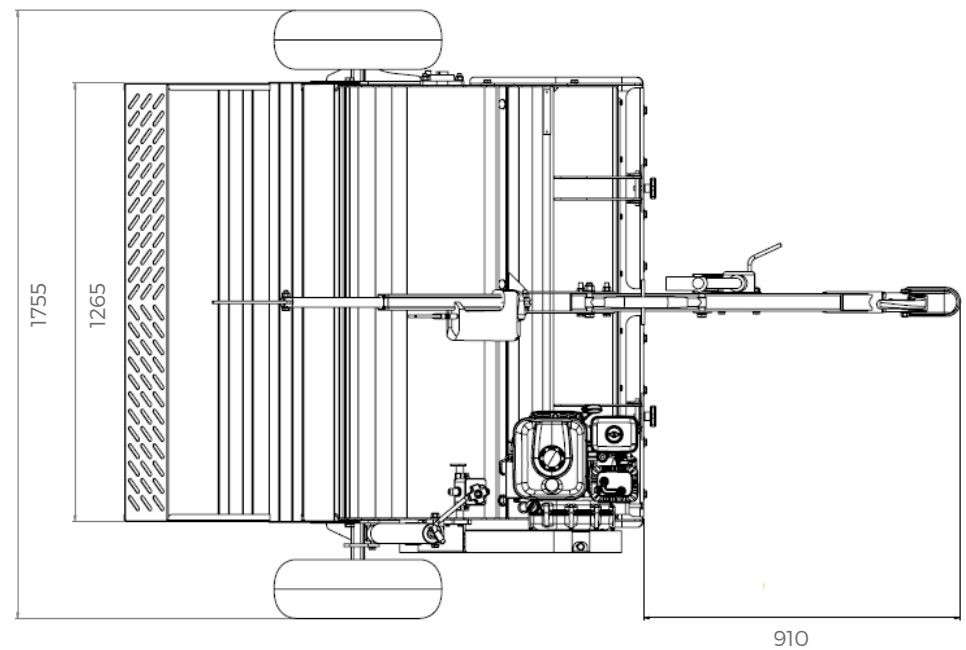
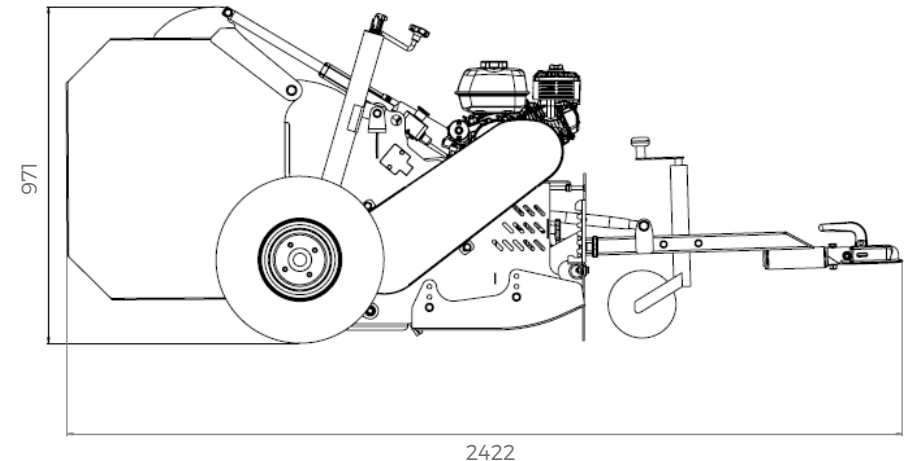

MG250

ARENA LEVELLER

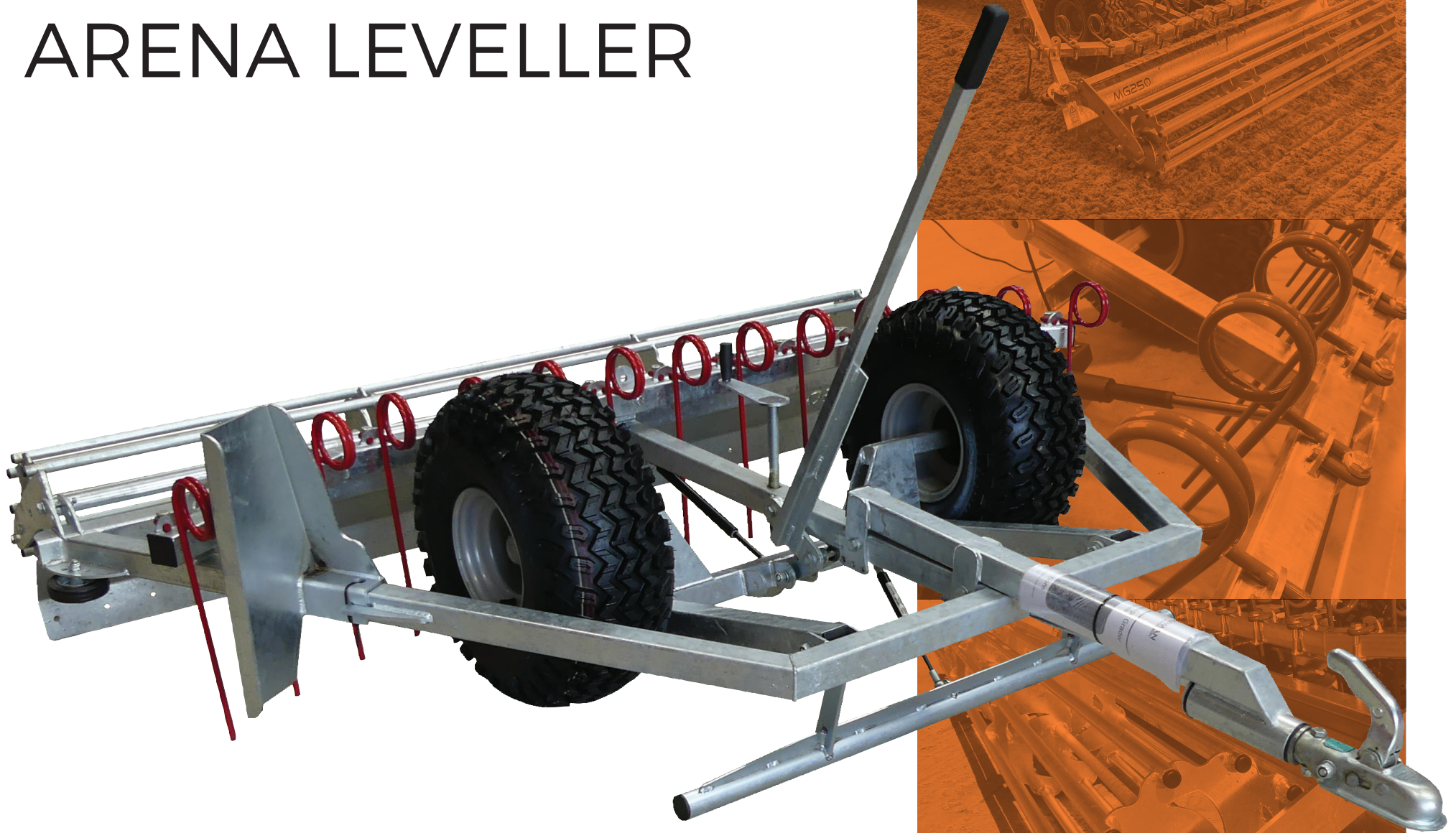

Model shown MG250+RR



The MG250 Arena Leveller is the perfect tool for levelling and grading all types of equestrian riding surface. Designed for ease of use and robust build, the MG250 will restore and maintain a top quality riding surface quickly and easily.

Built around a robust A-frame design, the MG250 can be supplied as a towed unit for use behind ATVs, 4x4s and large lawnmowers, or as a fully mounted unit for use behind a compact or mid-sized tractor.

Robust construction and a quality finish ensures years of trouble-free ownership and a consistent riding surface. Our unique work / transport modes allow you to maintain the grading depth consistently, and to easily change between modes using the integrated lever.

TECHNICAL FEATURES

- Robust 50mm box section steel frame for durability
- Large flotation tyres for smooth travel over uneven arenas
- Heavy duty 13mm agitation tines
- Perimeter blade
- Integrated running board wheels
- Transport / work modes for repeatable grading results
- Hardened levelling blade

OPTIONS



Rear Roller

Consolidates and aligns fibres on wax / fibre stabilised surfaces



3 Point Linkage Mounted

Mounted version of MG250 for 3 point linkage



Electric Lift

Electric actuator controlled grading depth in place of manual lift lever

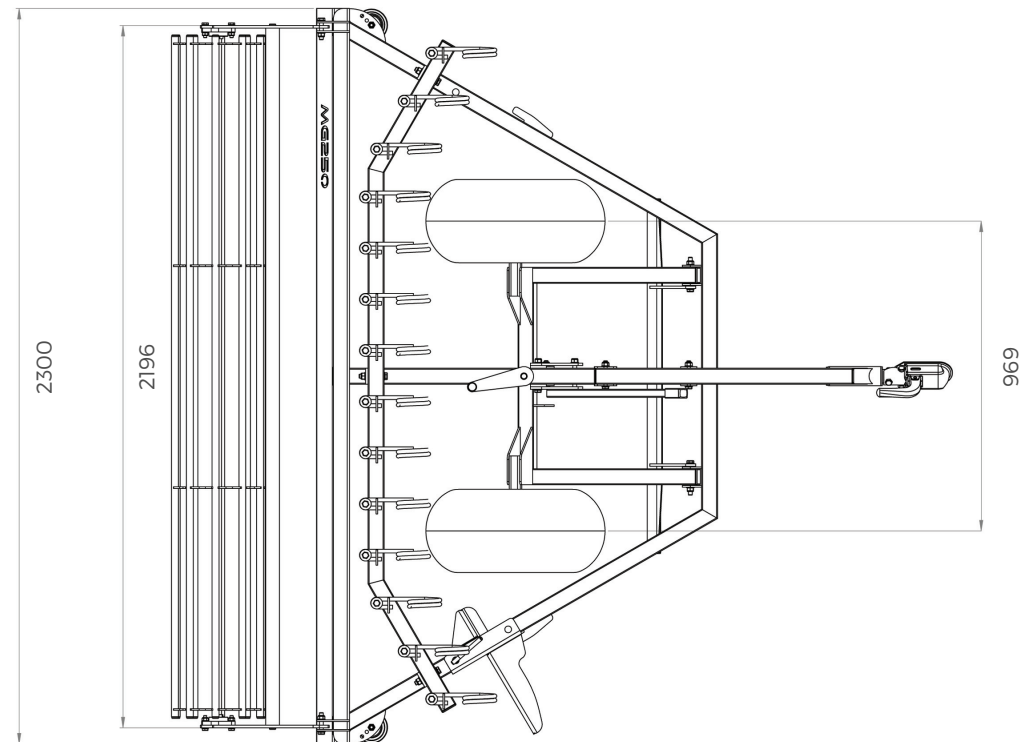
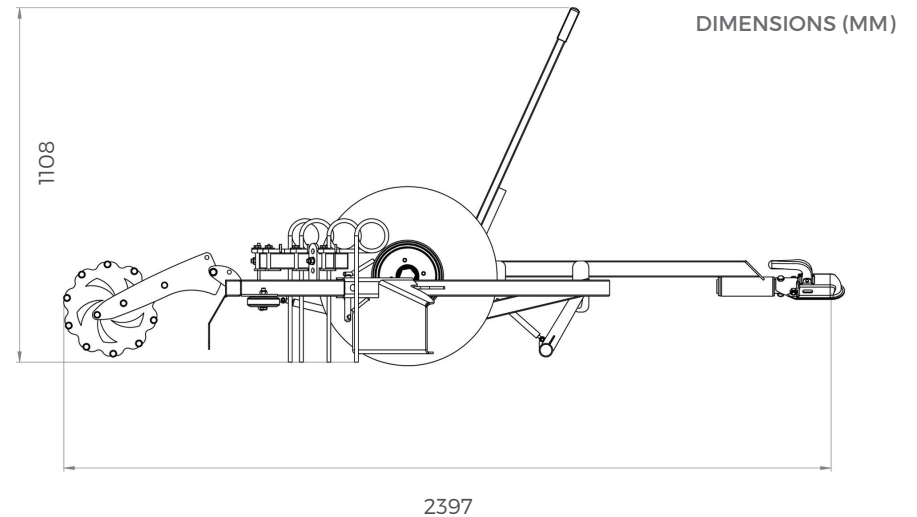

TH200 TINE HARROW



Model shown TH200



Electric Lift



The TH200 is the latest in the range of time saving, innovative equipment from Chapman Machinery. The TH200 is a trailed ATV/UTV Tine Harrow with electric lift for easy lowering/raising of the wheels for when the harrow is in use. With 2.0m working width and heavy duty fixed spring tines on a steel frame give the TH200 exceptional performance in levelling, aerating & scarifying surfaces allowing for a healthier paddock/field.

The four row's of 40 7mm Harrow Spring Tines helps removal of dead thatch & moss whilst scarifying and aerating the ground to help promote healthy grass growth with superb results. Spring tines are proven to give superior results over traditional chain harrows whilst saving time - easily adjust the aggressiveness of the tines with three tine settings and easy to use lever. The TH200 comes with flotation tyres for travel between fields with ease and it's 12v electric lift actuator let's you simply raise & lower the tines with a remote switch on the back of your ATV/UTV.

The TH200 can also be used to level and grade arenas, sand schools and gallops - careful and timely maintenance can make the difference between a long-lasting, brilliant riding surface, and a hard, dusty surface which can endanger both you and your horses.

Other benefits include:

- Removal of small rooted weeds
- Break up of livestock/horse manure in fields & paddocks
- More light and air reaching the soil from removal of thatch & moss
- Levelling of surface from mole hills and heavy soil
- Preparing the ground for grass seed

SPEC	TH200
Weight	170kg
Working width	2.0m
Tyres	19 x 7 x 8"
Number of Tines	40
Ground Clearance	170mm
Actuator	12v

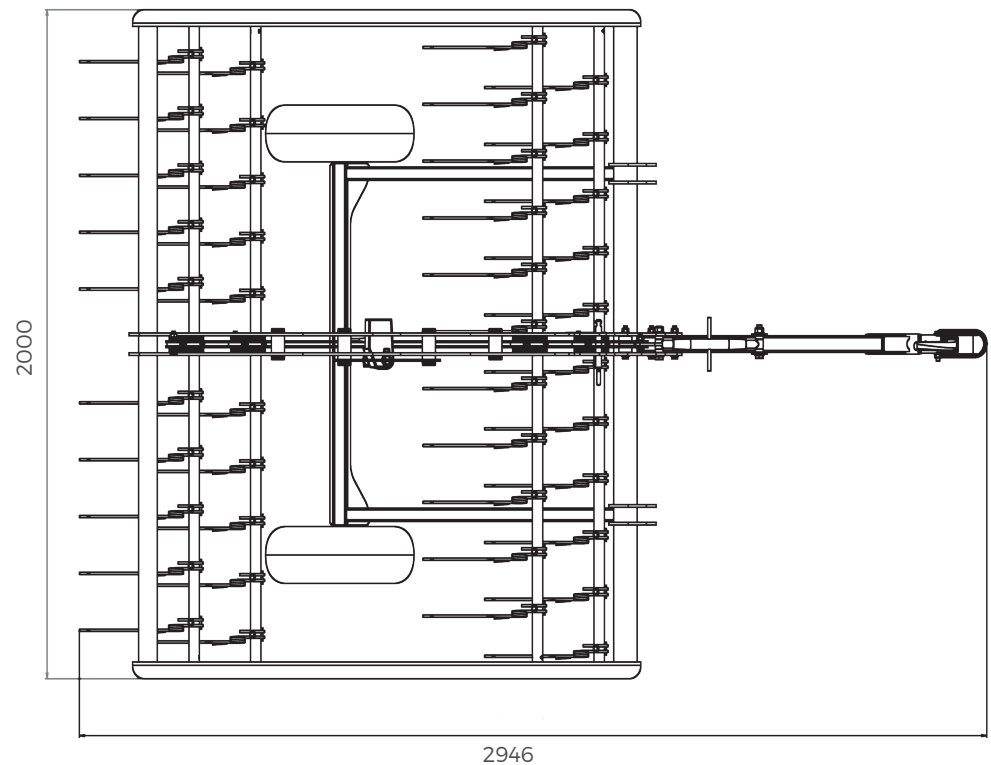
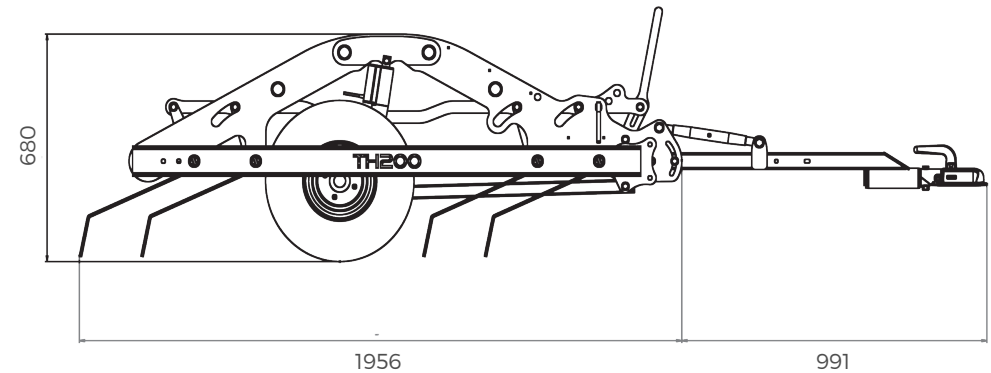

W240 WEED WIPER



Electronic Control Box

The W240 Weed Wiper is a simple, robust, yet highly effective tool for the selective application of herbicide to undesirable weeds such as reeds, rushes, bracken and thistles. A unique electric drive system eliminates dripping due to oversaturation and ensures consistent application and killing of weeds.

A robust tubular steel frame is used to ensure weeds flow smoothly through the machine, under the huge 200mm (8") diameter central wiping roller, which with its unique electric drive mechanism rotates at a constant speed, regardless of forward speed of the towing vehicle. Cleverly profiled steelwork directs any overspray from the application spray nozzles back onto the roller, which, combined with the constant rotation speed virtually eliminates dripping, even when moving between weed patches or at gateways.

A fully integrated 55 litre tank with integrated hand-lance for spot spraying, and IP67 sealed control electronics make for easy attachment and set-up. Roller rotation is controlled through a simple on/off switch and the herbicide application rate is controlled by a simple rotary adjustment on the electronic control module.

TECHNICAL FEATURES

- Unique electric drive roller eliminates dripping associated with ground-drive machines
- Tubular steel frame for smooth in-flow of weeds
- Profiled steelwork directs nozzle overspray onto top of wiper roller
- Integrated 55L tank
- Simple and robust IP67 sealed electronic controls
- Easy height and offset adjustment
- Narrow 19x7x8" flotation tyres for low ground pressure without transferring chemical or 'striping'

SPEC	W240
Weight	170kg
Tank Capacity	55L
Tyre Size	19 x 7 x 8"

OPTIONS



Brush Applicator

Upgradable applicator from carpet to brush for precise application

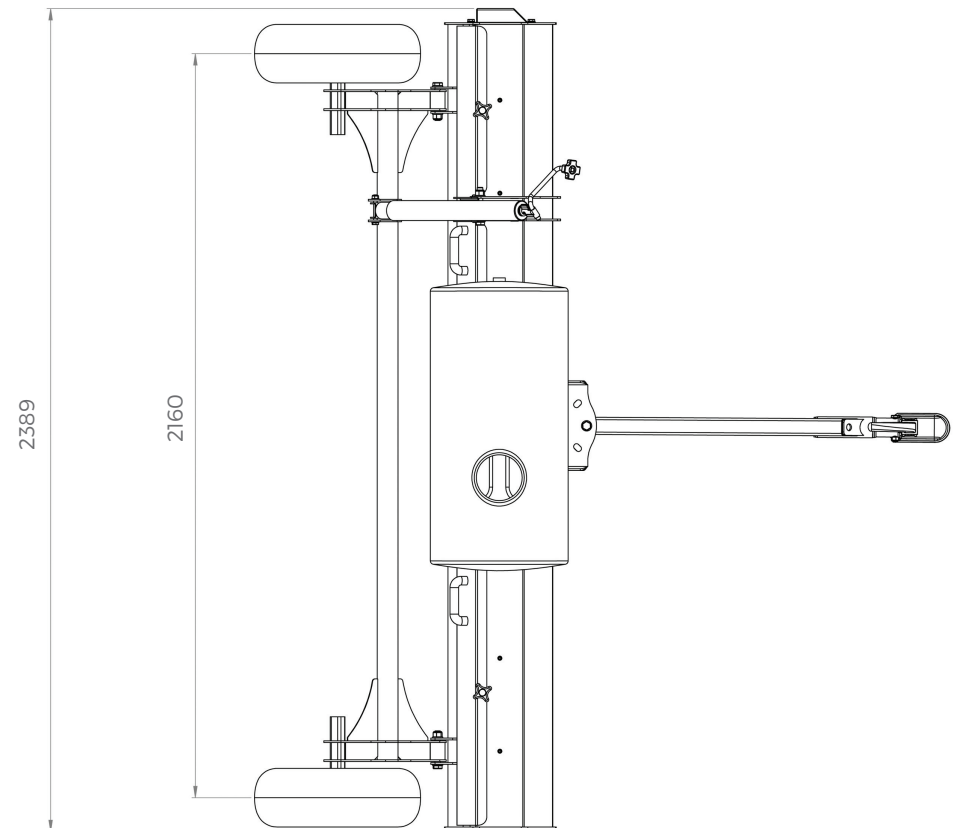
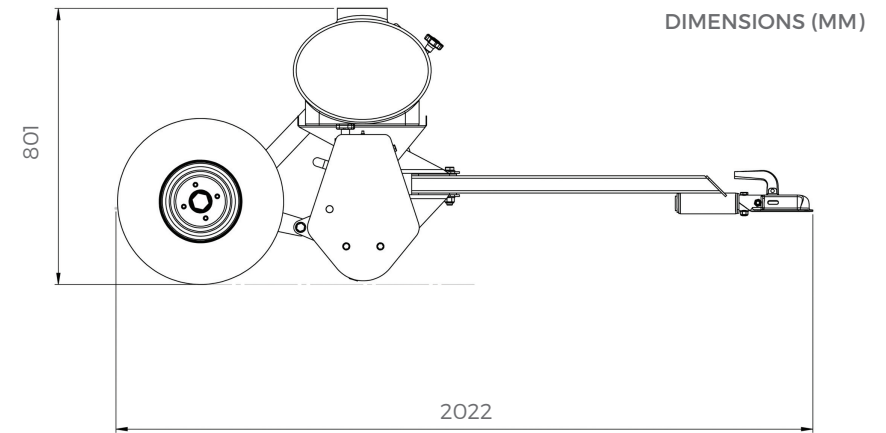

TF350

TRAILED LIVESTOCK FEEDER



Electronic Control Box

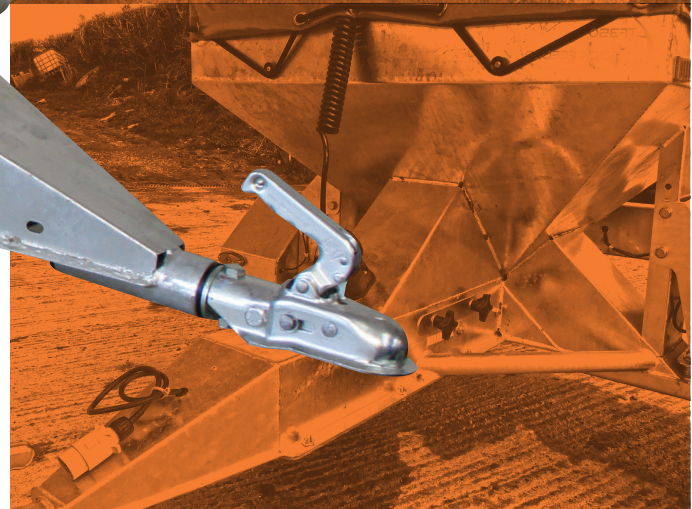
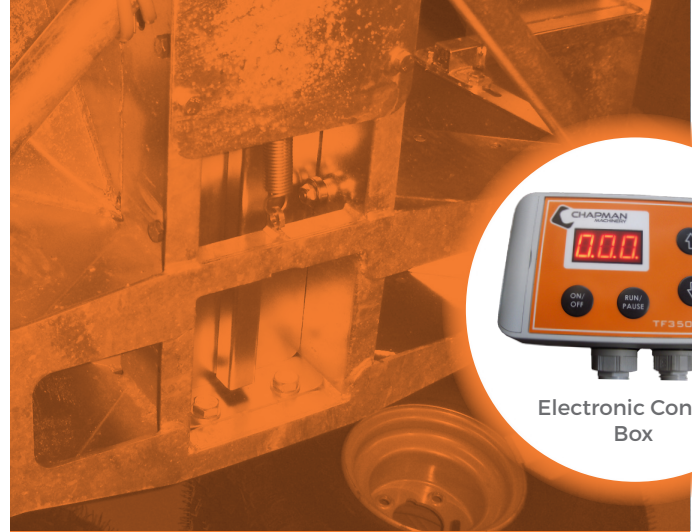

The TF350 Trailed Feeder is the ideal tool for easily and accurately feeding sheep, cattle and other livestock out in the field. Forget the tedious task of feeding with bags and troughs, feed your stock from the comfort of the towing vehicle, onto a clean patch of ground each day, ensuring each animal gets equal access to feed and preventing field damage when using fixed troughs.

Manufactured from 2mm and 5mm structural steel, and fully galvanised for durability, the TF350 is designed for the tough conditions experienced on farms when feeding stock, particularly in the winter months. The electronic drive system drops adjustable piles of feed (0.5-2kg approx), with the drop spacing altered by the forward speed of the towing vehicle, allowing larger or smaller stock to be accounted for.

With a 300kg hopper capacity as standard, and optional extension sides taking capacity to 500kg, as well as a range of other options to tailor to your specific requirements, the TF350 suits a huge range of farms and feeding situations.

Industry leading 300mm (12") ground clearance and a choice of tyres and axle options to handle rough or wet terrain, coupled with our unique electronic countdown timer makes for easy and efficient feeding, and allows the user to focus on checking stock condition. Unlike drum-type snacker feeders the electronic drive module only runs when feeding, meaning minimal wear occurs on the machine when travelling between fields, and reducing the burden on the towing vehicle. Fully galvanised steel construction will not fade and crack like plastic hoppers.

SPEC	TF350
Weight	135kg
Cubic Capacity	300kg (0.3 Cubic Meters)
(with extension sides)	500kg (0.6 Cubic Meters)
Ground Clearance	300mm (12")

TECHNICAL FEATURES

- Unique electronic control box with countdown function
- Fully galvanised steel construction
- Heavy duty reinforced mudguards
- Industry leading 300mm (12") ground clearance
- Simple and robust IP67 sealed electronic controls
- Tool-less drop calibration and adjustment
- 22x11x8" flotation tyres as standard or choice of flotation / road going axles and tyres
- Low fill height for ease of loading

OPTIONS



Oversize Tyres - 25x13x9"

Oversize flotation tyres with chevron tread pattern for reduced ground pressure and improved ground clearance, ideal for wet or steep terrain



Extension Sides

Bolt on extension sides, increase hopper capacity by approx. 200kg (varies with feedstuff)



Nudge Bar

Livestock fender bar, ideal for deflecting over-eager sheep when feeding large flocks



Twin Axle

Twin rocking beam axle for reduced ground pressure and improved travelling over rough / wet terrain



Road Legal

Range of suspension axles / tyres and lights to enable road travelling



Additional Control Box

Additional control box to allow use behind a second towing vehicle

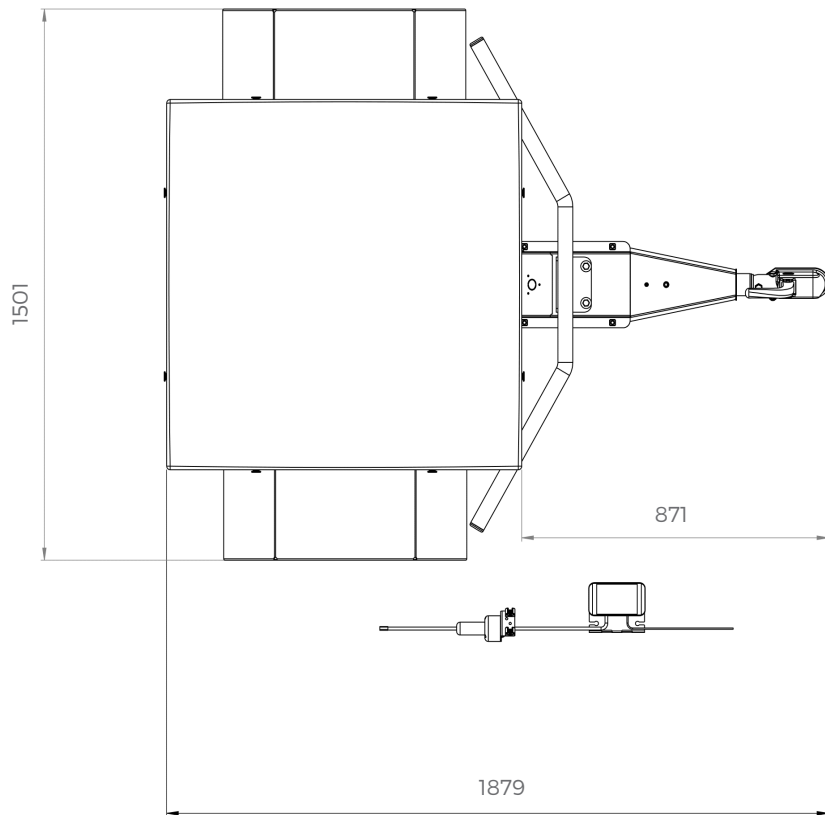
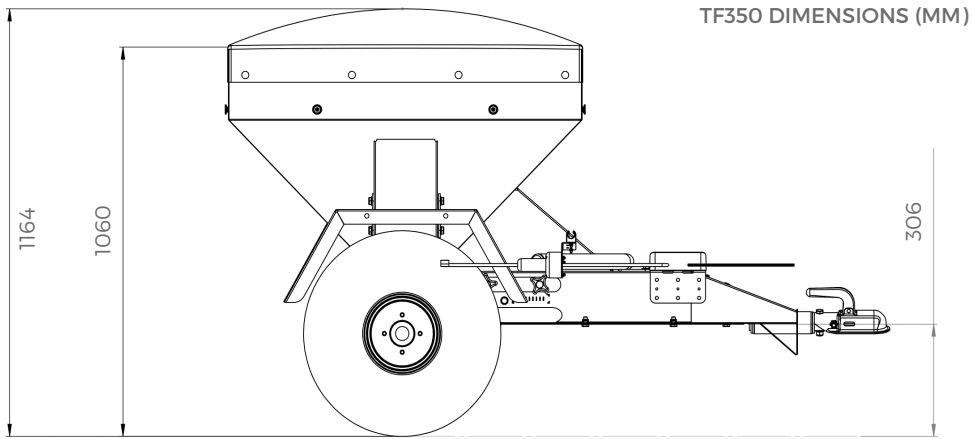

TF350

ROAD LEGAL OPTION

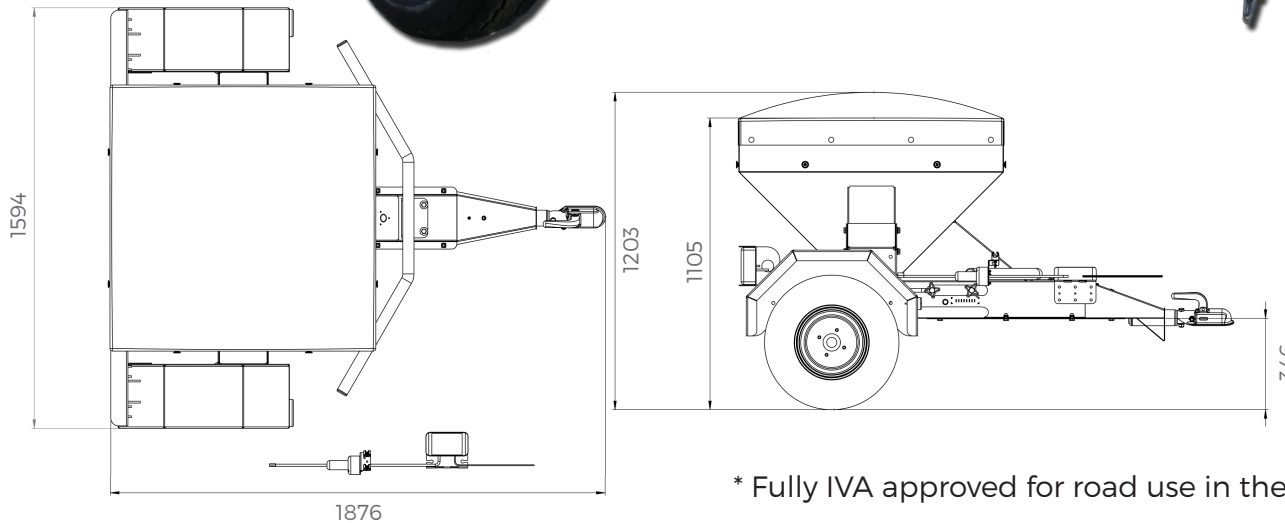

* Fully IVA approved for road use in the UK & EU



LED Lighting

Fitted as standard with super bright full LED lighting with reversing lights for vehicles supplied with 13 pin wiring and 7 pin adaptor



Suspension Axles and Road Tyres

Suspension axles and E-marked road tyres in place of standard off-highway tyres for use on public highways

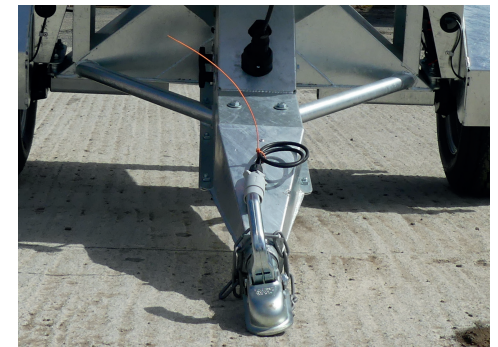

MF350

UTV MOUNTED FEEDER



Electronic Control
Box



The MF350 Mounted Stock Feeder (Sheep Snacker) is an electric drive spaced-drop feeder designed for fitment into a UTV or 4x4 pickup bed. Featuring fully galvanised all-steel construction and electronic operation with high-visibility digital counter ensures the right amount of feed is dispensed, exactly where you want it. Simple fitment into most popular UTVs, with drop deflection to allow use with a trailer.

The MF350 Livestock Feeder / Sheep Snacker allows you to drop the right amount of feed in the right place each time. Drop size is variable from 0.5kg to 2kg (approx), and drop spacing is controlled by the forward speed of the UTV or 4x4. Based on the same running gear as the TF350 Trailed feeder, the drive system and electronics are tried and tested. Furthermore the control module is interchangeable between mounted and trailed models.

The digital counter ensures you know exactly how much has been deposited, and allows you to focus on checking stock condition. Operable as either a count-up timer, from zero drops upwards, or as a countdown counter, whereby the desired number of drops is set, and the machine will deposit exactly that amount of feed, simply and reliably each and every time. Simple design, quality construction, and galvanised finish for a long lasting, reliable machine.

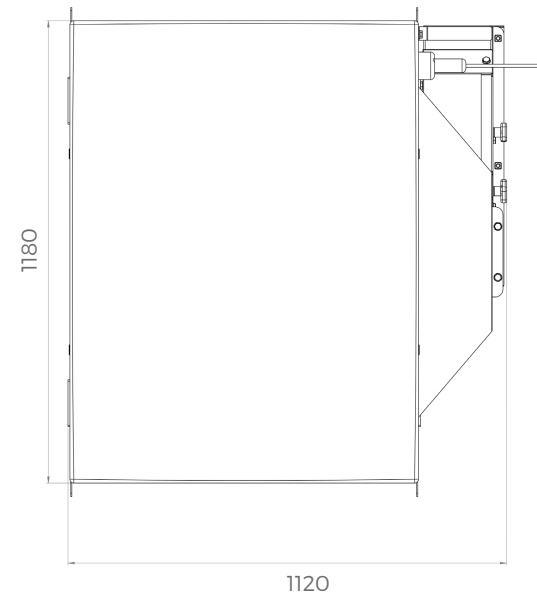
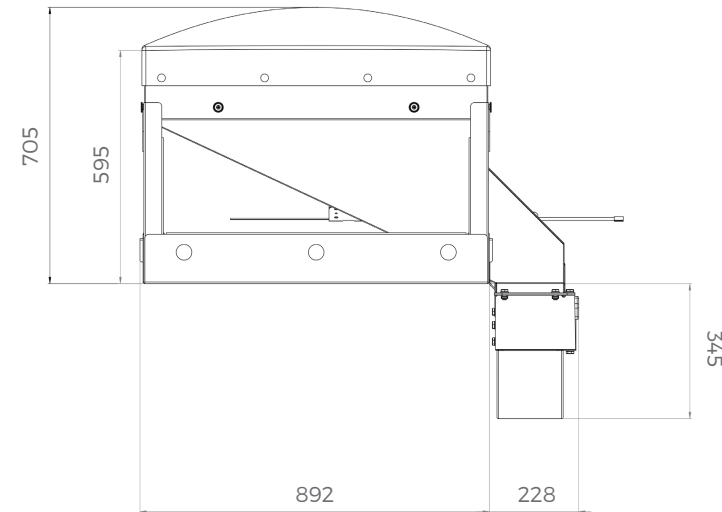

OPTIONS



Additional Control Box

Additional control box to allow use behind a second towing vehicle

SPEC	MF300
Weight	90kg (unladen)
Cubic Capacity	250kg (0.3 Cubic Meters)
Supply Voltage	13.8V Nominal
Operating Temp	-15/+50C (Min/Max)
Drops Per Minute	25

TGF350

TRAILED GAME FEEDER



Simple Electronic Operation

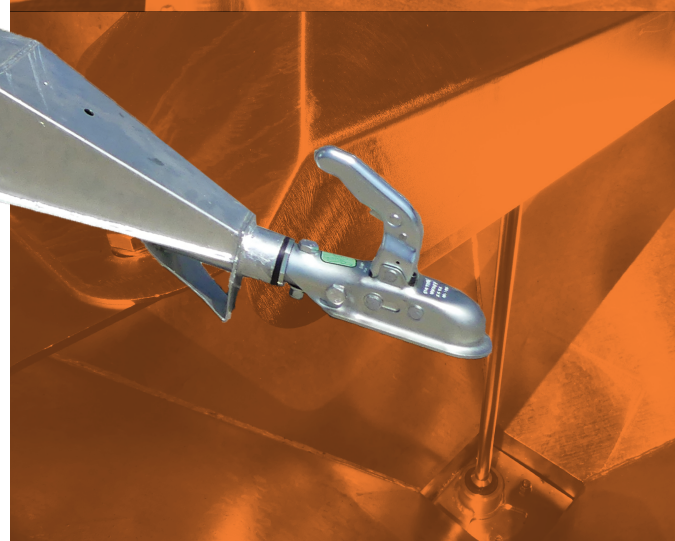
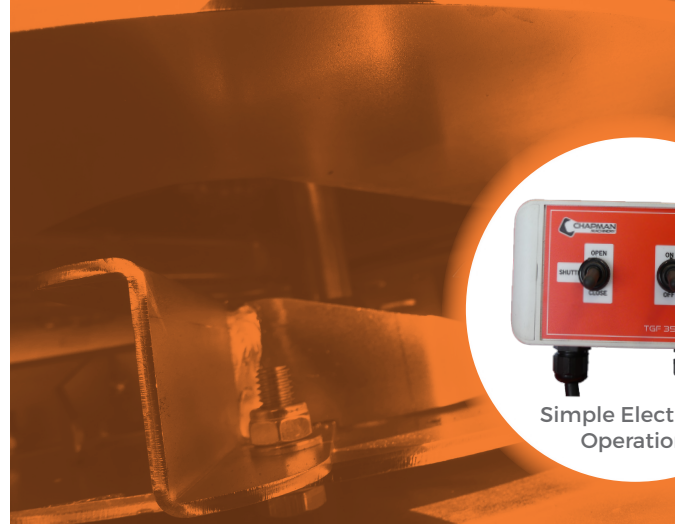

The TGF350 Trailed Game Feeder replaces the tedious task of feeding pheasants and game with bags. Simple remote electronic operation means feeding can be controlled from cab for ease of use. Featuring an all-steel, fully galvanised construction makes it a robust unit designed for easy towing and long durability.

The TG350 Trailed Game Feeder saves time and effort with the ability to carry around 300kg of feed as standard, with optional extension sides taking capacity up to 500kg. Fully sealed IP67 electrics operate in all weathers and conditions with an easy to use control box that the driver/ rider can operate the spinner from the cab/quad. Adjustable spinner deflector plates can further reduce or tailor the spread width for feeding down one side of cover crops or into pens.

Constructed from 2mm & 5mm steel, the TGF350 is designed for use behind an ATV, UTV or 4x4 (off-road only) for easy towing across woodlands & moorlands without being too heavy. Mudguards and PVC tonneau cover come as standard along with a heavy duty, high torque motor operating a variable vein spinning plate to provide strength & reliability. The electronic drive module only runs when feeding, meaning minimal wear occurs on the machine when travelling, reducing the burden on the towing vehicle and easy operation.

TECHNICAL FEATURES

- Simple tool-less feed rate adjustment
- 22x11x8" flotation tyres as standard
- Low fill height for ease of loading
- Heavy duty reinforced mudguards
- Industry leading 350mm (14") ground clearance
- IP67 sealed electronic controls

OPTIONS



Extension Sides

Bolt on extension sides, increase hopper capacity by approx. 200kg (varies with feedstuff)

SPEC	TF350
Weight	160kg
Cubic Capacity	300kg (0.3 Cubic Meters)
(with extension sides)	500kg (0.6 Cubic Meters)
Ground Clearance	350mm (14")
Tyres	22x11x8"
Spinner	Variable Vain @ 560rpm

TGF350 DIMENSIONS (MM)

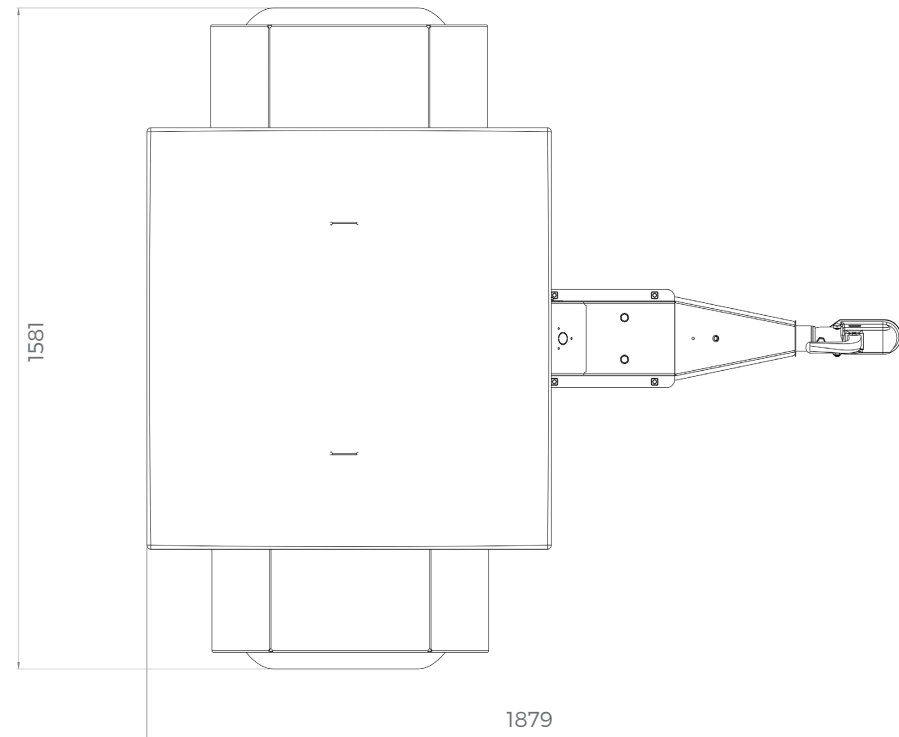
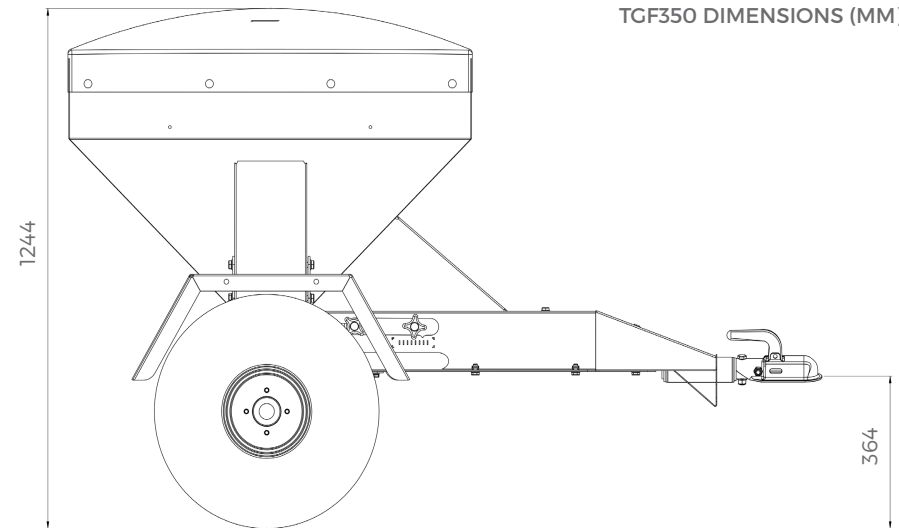

BT500 BALE TRANSPORTER / TRAILER



Twin Axle Model Shown



Wireless Remote
Winch

The BT500 Round Bale Transporter / Trailer is a simple yet robust tool for the transportation of round baled feed such as hay, straw or silage to wet ground beyond the reach of a conventional loader or tractor, or where a loader / tractor is not available.

Designed for use behind an ATV, UTV or 4x4 (off-road only) the low ground pressure and relatively light weight of the BT500 allows it to travel easily over rough or wet ground for feeding out-wintered stock. Alternatively, the BT500 can be used on smallholdings and in equestrian yards where a tractor is not available, allowing round bales to be used in place of small square bales at a considerable cost saving. The BT500 features an electric winch for loading and unloading the bale as standard, along with a remote control. This allows even the heaviest bales to be loaded with ease, and makes hitching and un-hitching the bale transporter quick and easy with just one small electrical plug connection to be made.

The innovative design of the BT500 round bale transporter means that the cradle arms automatically grip the bale as it is reversed up to it for loading, with only one small ratchet strap to be attached before the bale can be loaded securely and safely using the remote winch control.

TECHNICAL FEATURES

- Electric winch for easy loading & unloading of bales
- Robust galvanised steel chassis
- Available in single or twin axle configurations
- Remote control operation

OPTIONS



Twin Axle

Increases carrying capacity and reduces ground pressure as well as enabling smoother towing over rough ground.

SPEC	BT500
Working Width	1.7m
Weight (Unladen)	200kg
Max Bale Weight	500kg (Standard Axle) 750kg (Twin Axle)
Max Bale Diameter	1.5m (5')
Max Bale Length	1.5m (5')
Tyre Size	22 x 11 x 8"

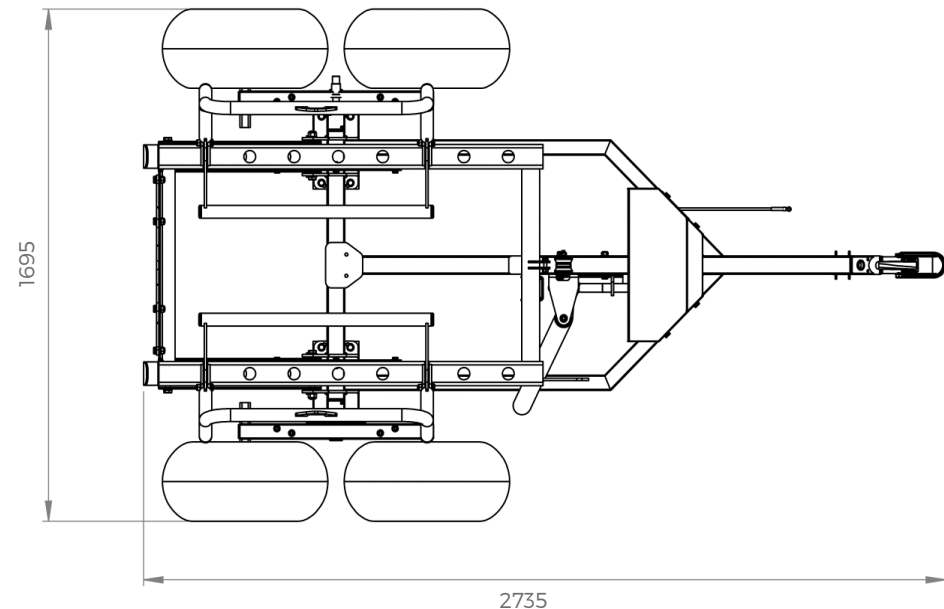
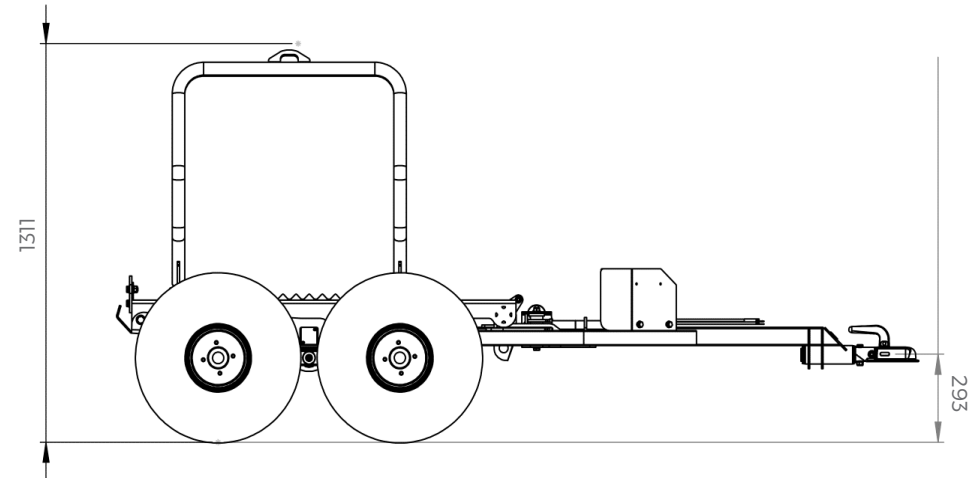

RT SERIES ROAD TRAILER



Canopy Model Shown



The RT ATV Road Going Trailers are an unbraked 750kg capacity trailer designed for professional use on farms, estates and smallholdings. Fully approved for road use within the EU, the box style trailer body come in two sizes; 7'x4'2" and 7'3"x4'7" both with removable, drop down perforated steel sides.

Featuring a folded steel A Frame drawbar and cast hitch, the RT trailers are designed to be both lightweight yet incredibly strong for maximum durability. 2mm laser cut steel panels are used for strength along with fold down sides complete with ventilation holes laser cut into them. This makes the drop down sides significantly stronger and less likely to fail than weldmesh sides. The drop down tailgate features an integral swing door, and is made from 2mm folded steel and aluminium chequer plate. The RT Series Trailers are all fully hot-dip galvanised and fitted with tough steel mudguards for longevity.

Aluminium flooring is fitted as standard and is both glued and riveted for a secure and rattle-free trailer. With added 20.5x8x10" flotation road tyres, this trailer will work equally well on-road as off-road. The A-Frame drawbar and suspensions axles ensure this trailer follows the towing vehicle without bouncing, even when empty. The RT Trailer also comes with an option of a livestock partition if required.

TECHNICAL FEATURES

- Laser cut folded steel construction
- Full LED Lighting with reverse
- Drop down perforated mesh sides
- Canopy and partition options

OPTIONS



Lifting Canopy

For livestock or goods carriage. Comes with gas assisted lift with auto locking on close for ease of use.

SPEC	RT200	RT220
Internal Dimensions	2.14 x 1.3m	2.2m x 1.3m
Weight (Unladen)	320kg	340kg
Max Load	750kg	
Floor Material	Aluminium Chequer Plate	
Coupling	50mm Ball	
Tyre Size	20.5 x 8 x 10"	

RT200 DIMENSIONS (MM)

RT220 DIMENSIONS (MM)

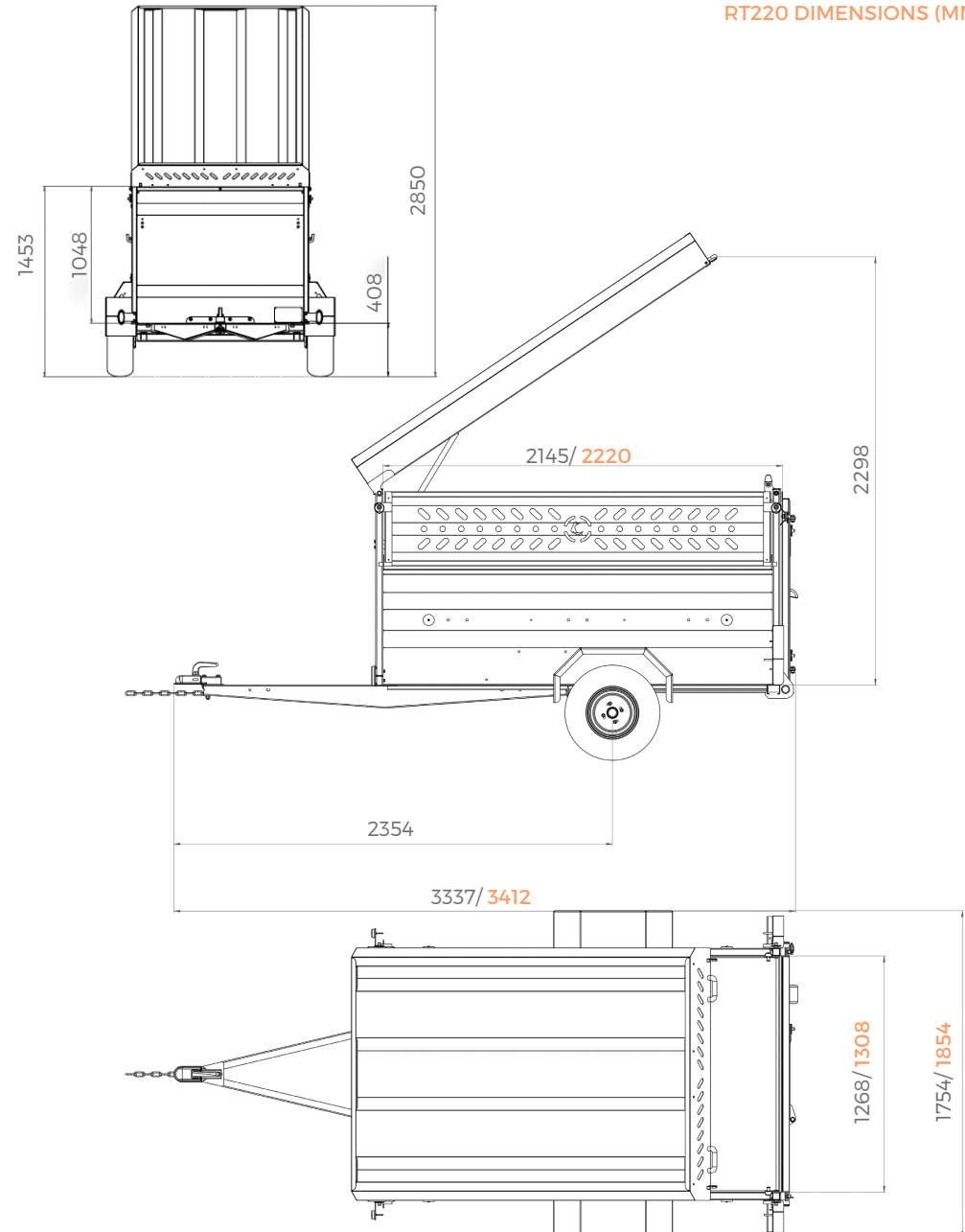

ST150 ATV TRAILER



The ST150 Stock Trailer has been designed to be a robust, reliable workhorse trailer on any farm, smallholding or estate. We've been manufacturing ATV attachments and trailers since 2010 and we have updated the design on our 5x3" (1m x 1.5m) stock trailer to ensure we remain the professional's choice of supplier.

The ST150 is a very high quality trailer, not to be confused with cheaper alternatives. We've been manufacturing trailers since 2010 and have used this experience to ensure we integrate all the features that make life easier for users.

Made from 2mm thick folded steel panels, laser cut for precision, with fully re-inforced joints and mounting points, this is a tough but not excessively heavy trailer designed for use on farms, smallholdings and estates. Aluminium treadplate floor is fitted as standard.

DIMENSIONS (MM)

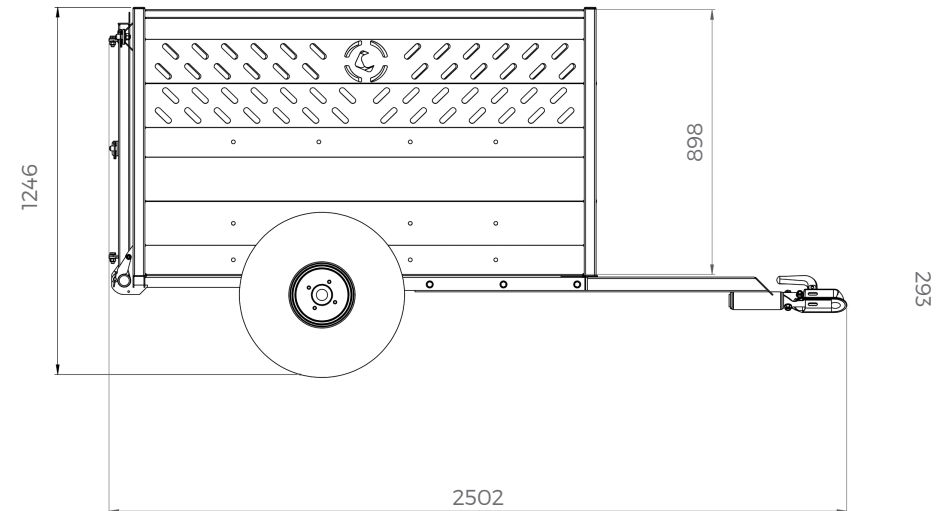

TECHNICAL FEATURES

- Robust 2 mm folded steel sides with laser cut vents
- Bolt on axles for ease of replacement or fitment of larger tyres or twin axles
- Ramp tailgate with integrated swing door
- Draw bar can be rotated to accommodate different tow ball heights over uneven arenas
- Large, good quality 22x11x8" flotation tyres for easy towing
- Glued and riveted floor aluminium tread plate floor and rear door to reduce noise
- Tried and tested British manufactured swivel hitch
- High speed axles with sealed angular ball bearings

SPEC	ST150
Weight (Unladen)	150kg
Floor Material	Aluminium Chequer Plate
Steel Thickness	2mm Folded Sides, 5mm Axle
Tyre Size	22 x 11 x 8"

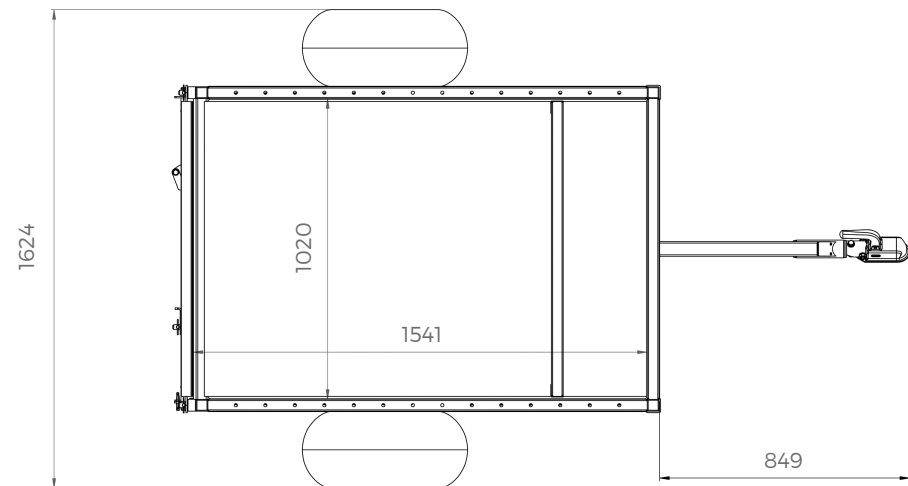

HOW TO BUY

At Chapman we strive to give you the best possible service from design to after sales technical support. That's why we have teamed up with distributors across the UK & EU so you can get all the benefits of a dedicated design and manufacturing company with local customer service.



WHERE'S MY NEAREST DISTRIBUTOR?

Finding your nearest distributor couldn't be easier. We have an interactive online map to easily locate your local Chapman dealer and provide you with their contact details.

www.chapman.co.uk/distributors

Alternatively you can pick up the phone and give us a call on **+44(0)1288 308 149** to speak with one of our advisors who can help find your local dealer for you.



BUYING FROM DISTRIBUTORS

Buying from distributors has many benefits. It means at Chapman we can produce market leading, high quality machinery at a competitive price point without the need for large overheads meaning a better price for you, the customer.

All purchases through distributors still come with our industry leading 2 year warranty. You will always find cheaper machinery on offer, but we are confident you won't find better whole-life value and better customer service.



AFTER SALES SUPPORT

Buying through one of our distributors means you will get great local customer service and support for your Chapman machine.

We are also available for any more in-depth questions or support so please don't hesitate to call us on **+44(0)1288 308 149** or email sales@chapman.co.uk and we will be more than happy to help.

NOTES

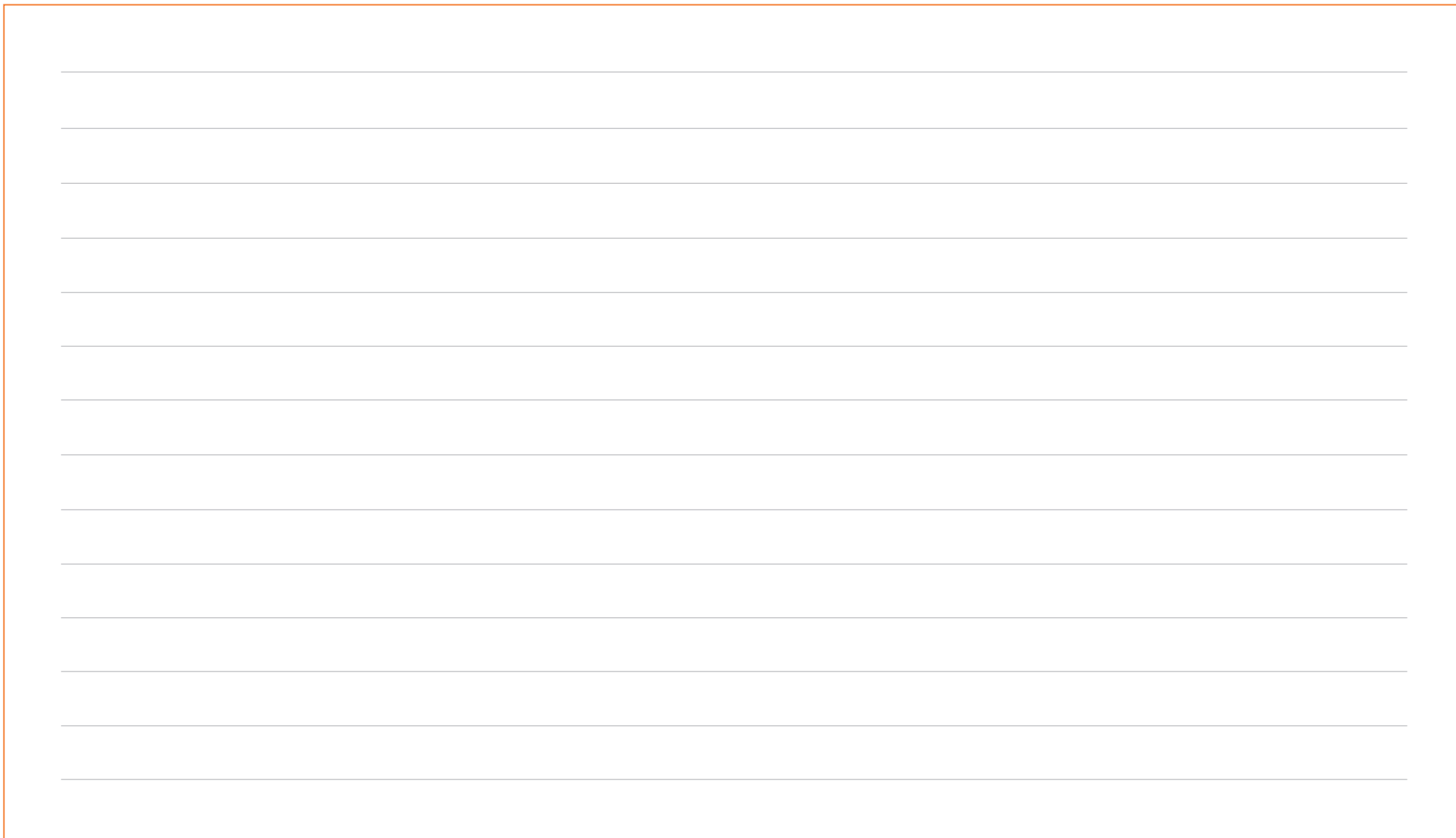

A large rectangular box with a thin orange border, containing 15 horizontal grey lines for writing notes. The lines are evenly spaced and extend across the width of the box.



Chapman Machinery Ltd, Hele Barton, Week St. Mary, Holsworthy, Devon, UK, EX22 6XR
Tel: +44(0)1288 308149

WWW.CHAPMAN.CO.UK

sales@chapman.co.uk