

Fair-Play

A TRANS·LUX® COMPANY

**OUTDOOR PORTABLE SCOREBOARD
INSTRUCTION MANUAL**

REVISION DATE: 09-18-06

PART#: 98-0038-01

Fair-Play

A TRANS·LUX® COMPANY

SERVICE & CUSTOMER INFORMATION

CUSTOMER MUST HAVE PART NUMBER WHEN ORDERING ITEMS THROUGH THE SERVICE DEPARTMENT.

IF FURTHER HELP IS NEEDED, CONTACT A FAIR-PLAY SERVICE AGENT IN YOUR FAIR-PLAY DEALER ORGANIZATION OR PHONE THE FAIR-PLAY HELP DESK AT (800) 462-2716.

TO AID YOU IN YOUR DISCUSSIONS WITH SERVICE AGENTS, WE SUGGEST THAT YOU RECORD THE FOLLOWING:

MODEL NUMBER: _____

FAIR-PLAY SALES ORDER NUMBER: _____
(THIS NUMBER IS FOUND IN THE UPPER RIGHT HAND CORNER OF THE PACKING SLIP AND INVOICE.)

INSTALLATION DATE: _____

WARRANTY: A COPY OF THE **FIVE-YEAR LIMITED WARRANTY** IS ENCLOSED.

FAIR-PLAY SCOREBOARDS

DES MOINES, IOWA

INSTRUCTION DRAWING LIST

OUTDOOR PORTABLE SCOREBOARD

TABLE OF CONTENTS

DESCRIPTION	DRAWING NUMBER
PSO-6900 FACE VIEW AND INSTALLATION.....	01-6900-01
CART ASSEMBLY INSTRUCTIONS.....	62-0000-05
WIRING #297 PLUGS WITH 2 CDR. CABLE.....	ZN-6-A391-3
OPERATING INSTRUCTIONS.....	98-0038-01-1
PRECAUTIONS FOR HANDLING VALVE-REGULATED LEAD-ACID BATTERIES.....	98-0025-01
SCOREBOARD CARE - OFF SEASON.....	EL-1527
TROUBLE SHOOTING FOR OUTDOOR SCOREBOARDS.....	01-0008-06
WARRANTY	

Fair-Play

A TRANS·LUX· COMPANY

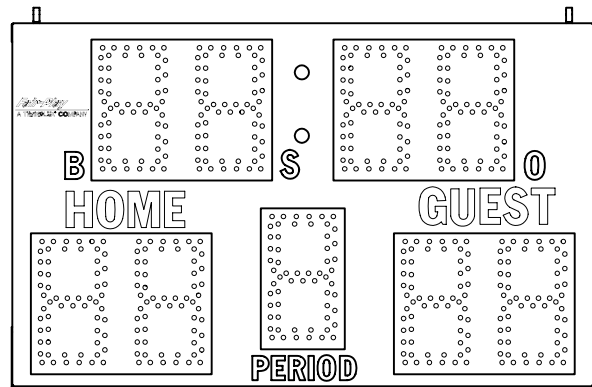

**PSO-6900-2
PORTABLE SCOREBOARD**

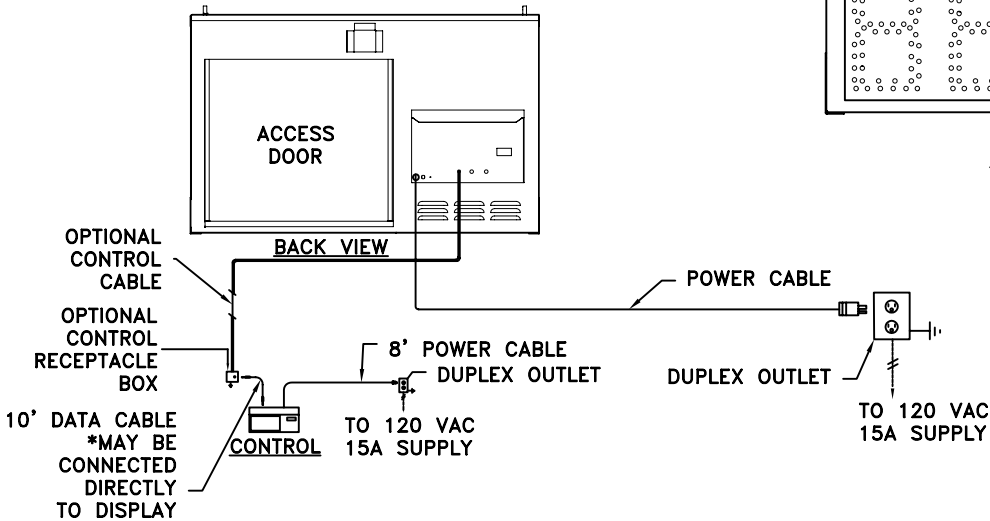

PSO-6900-2

SIZE: 4'-0"L X 2'-6"H X 6.25"D

POWER: 120 VAC, 50/60 Hz., 1-PHASE
37 WATTS.

CONTROL CONSOLE: MP-70 OR MP-50.
CONTROL CABLE: (1) TWO CONDUCTOR SHIELDED. (C0550)

COMES WITH TRAVEL CART (62-0000-05)

OPTIONS: HORN KIT. (12-0010-06)

BATTERY KIT, FACTORY INSTALLED ONLY, RUN TIME 6 HOURS. (12-0010-04)

WIRELESS BATTERY KIT, FACTORY INSTALLED ONLY. (16-0019-03)

WIRING DRAWING: 12-0010-03.

ESTIMATED WEIGHT: 50 LBS. (120 VAC)
65 LBS. (WITH BATTERY)

WATER INGRESS

NO ADDITIONAL PENETRATIONS MAY BE CREATED IN THE PRODUCT UNLESS THEY ARE SEALED PER NEMA 4 STANDARD. ALL FIELD PENETRATIONS MUST BE TESTED USING A STREAM OF WATER POURED FROM A CONTAINER LOCATED NOT LESS THAN 6" AWAY HORIZONTALLY. WARRANTY WILL BE VOID IF THIS TESTING IS NOT COMPLETED DURING INSTALLATION, OR IF THERE IS WATER INGRESS FROM FIELD MODIFICATIONS. ANY CABINETS LOCATED ABOVE THE PRODUCT MUST NOT ALLOW WATER TO BUILD UP AND THEN FLOW THROUGH CONDUITS INTO THE PRODUCT. PENETRATIONS BETWEEN PRODUCT AND HIGHER CABINETS MUST BE SEALED BETWEEN THE CABINET INTERNAL SPACES USING WATER TIGHT CABLE TO CONDUIT SEALS. HOLES REMAINING FROM EYE BOLT REMOVAL MUST BE FILLED, SEALED AND TESTED.

VENTILATION

INSTALL PRODUCT SO THAT AIR FLOW IS NOT RESTRICTED. CUSTOMER'S STRUCTURE MUST ALLOW FOR THE FREE FLOW OF OUTSIDE AMBIENT AIR TO THE PRODUCT, WITHOUT RECIRCULATION OF AIR. WARRANTY WILL BE VOID IF COMPONENTS FAIL DUE TO AIR FLOW RESTRICTIONS.

WEB ADDRESS
FAIR-PLAY SCOREBOARDS
FACTORY ADDRESS
PHONE

fair-play.com
PO BOX 1847
1700 DELAWARE AVE.
515-265-5305

DES MOINES, IOWA 50305-1847
DES MOINES, IOWA 50317-2999

C	ADDED WATER & VENTILATION NOTES	09-18-06	BEW	121202 DLS 01-6900-01
B	UPDATED CART INFORMATION	9/4/03	WJG	
A	REVISED FACEVIEW	1/10/03	WJG	
REV.#	CHANGE	DATE	BY	

TOOLS REQUIRED:
 PHILLIPS HEAD SCREWDRIVER
 7/16" WRENCH/SOCKET OR ADJUSTABLE WRENCH
 RUBBER Mallet

ASSEMBLY NOTES:
 BEFORE STARTING COUNT THE NUMBER OF PARTS AND COMPARE TO THE PARTS LIST SHOWN ON THIS PAGE.

ALL CONNECTION POINT WILL REQUIRE ONE EACH OF THE FOLLOWING PARTS: SCREW, FLAT WASHER, STAR WASHER, AND NUT (OR THREADED INSERT WHERE THE CART MEETS THE SCOREBOARD).

STEP1:
 REVIEW AND UNDERSTAND THE INSTRUCTIONS SHOWN ON THIS PAGE. THE DRAWING TO THE RIGHT SHOWS AN EXPLODED VIEW OF THE CART ASSEMBLY. PLEASE NOTE THAT NOT ALL REQUIRED HARDWARE IS SHOWN.

STEP 2:
 ATTACHED THE FRONT AND REAR GUSSET TO THE FRONT STAND OR AXLE SUPPORT RESPECTIVELY.

STEP 3:
 ATTACH ASSEMBLIES FROM STEP 1 TO THE SCOREBOARD. BOTH ASSEMBLIES SHOULD ATTACH AT BOTH THE SIDE AND BOTTOM OF THE SCOREBOARD.

STEP4:
 SLIDE THE AXLE THROUGH BOTH WHEELS AND THE AXLE SUPPORT. PUSHNUTS WILL HOLD THE WHEELS IN PLACE AND SHOULD BE SECURED USING A RUBBER Mallet.

STEP5:
 THE FINISHED CART SHOULD LOOK LIKE THE PICTURE SHOWN BELOW.

Parts List		
ITEM	QTY	DESCRIPTION
1	2	5-SPOKED WHEEL
2	1	AXLE SUPPORT
3	1	FRONT GUSSET
4	1	FRONT STAND
5	1	PAINT DETAIL, PORTABLE
6	2	PUSHNUT, 1/2"
7	1	REAR GUSSET
8	1	REAR GUSSET
9	1	ROD, 1/2" DIA. X 35"
10	25	SCREW, 1/4"-20, PHILLIPS
11	25	WASHER, 1/4", STAR
12	25	WASHER, 1/4", FLAT
13	10	NUT, 1/4"-20

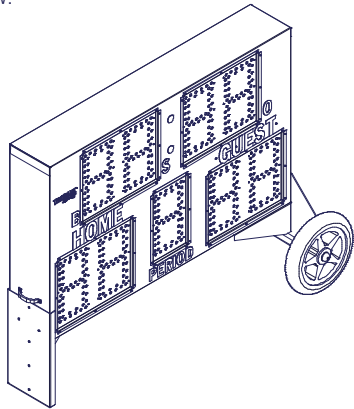
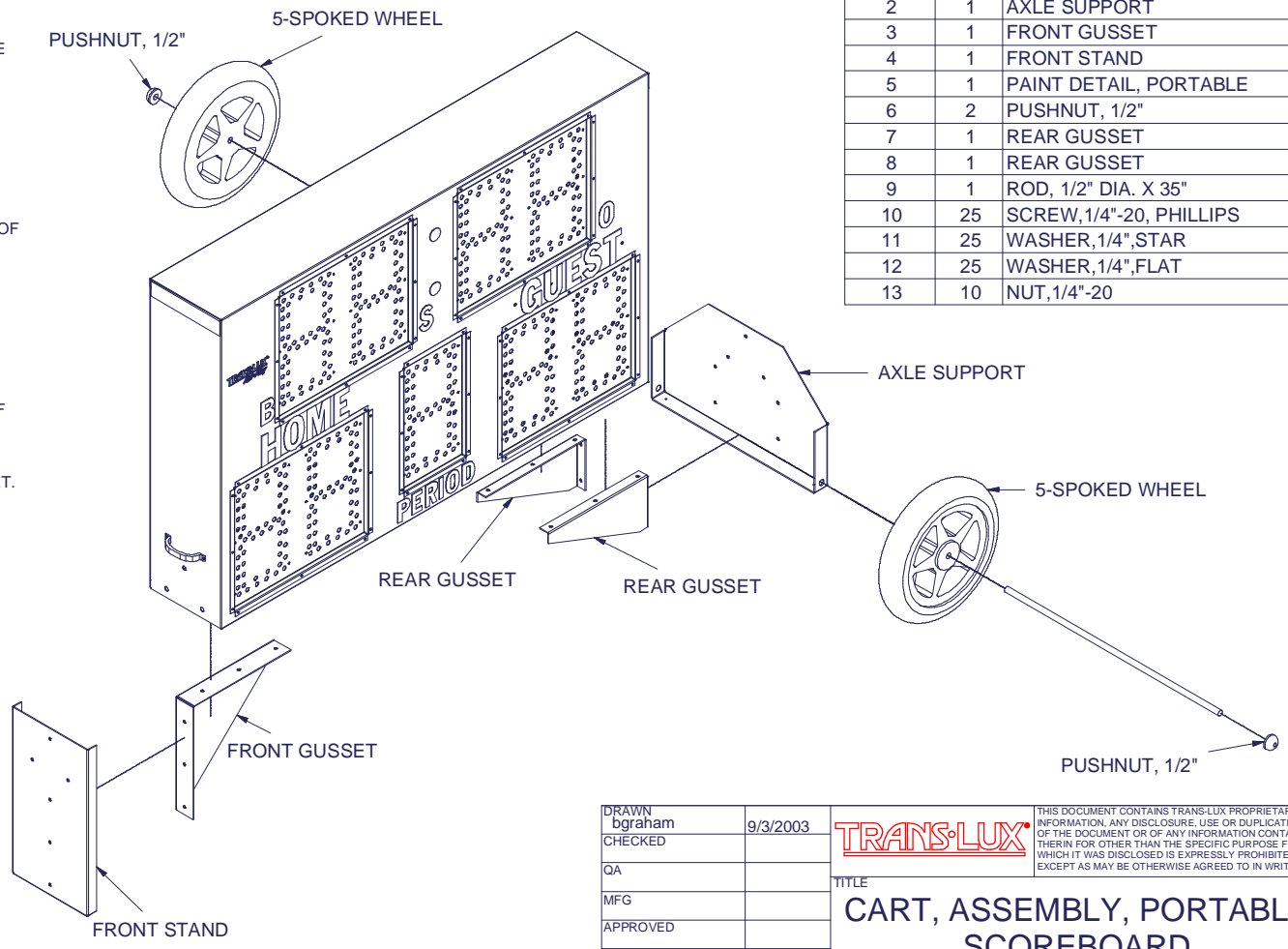

COMPLETED CART

DRAWN bgraham	9/3/2003	TRANS-LUX	THIS DOCUMENT CONTAINS TRANS-LUX PROPRIETARY INFORMATION. ANY DISCLOSURE, USE OR DUPLICATION OF THE DOCUMENT OR OF ANY INFORMATION CONTAINED THEREIN FOR OTHER THAN THE SPECIFIC PURPOSE FOR WHICH IT WAS DISCLOSED IS EXPRESSLY PROHIBITED, EXCEPT AS MAY BE OTHERWISE AGREED TO IN WRITING.
CHECKED			
QA			
MFG			
APPROVED		TITLE CART, ASSEMBLY, PORTABLE SCOREBOARD	
		SIZE B	DWG NO 62-0000-05
		SCALE	REV OR
			SHEET 1 OF 1

2 CDR.
TWISTED PAIR (C0550)

(-----)'

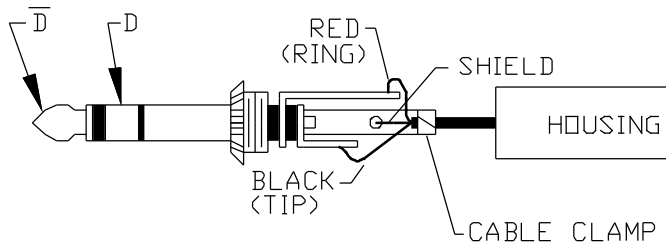
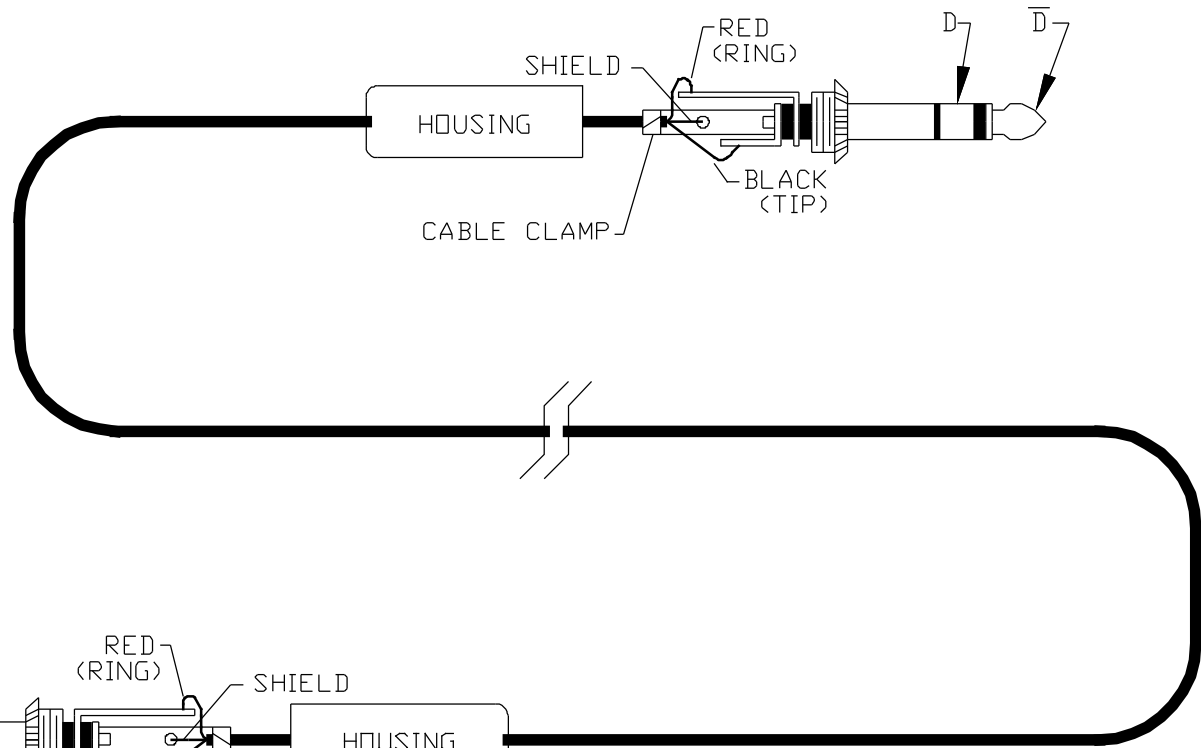

PLUG DETAIL
(#297 PLUG)
(C0483) 2-REQ'D

TRANS·LUX
Fair-Play

1700 DELAWARE AVE.
DES MOINES, IA 50317

THIS DOCUMENT CONTAINS FAIR-PLAY PROPRIETARY INFORMATION. ANY DISCLOSURE, USE OR DUPLICATION OF THE DOCUMENT OR OF ANY INFORMATION CONTAINED THEREIN FOR OTHER THAN THE SPECIFIC PURPOSE FOR WHICH IT WAS DISCLOSED IS EXPRESSLY PROHIBITED, EXCEPT AS MAY BE OTHERWISE AGREED TO IN WRITING

TITLE	DRAWN BY	MODEL:
WIRING #297 PLUGS WITH 2 CDR. CABLE	MEB	A
	DATE	DWG. NO.
	12-7-96	ZN-6-A391-3
	SCALE	
	NONE	

OR	UPDATED TITLE BLOCK	9/05/02	DLS
REV.#	CHANGE	DATE	BY

OPERATING INSTRUCTIONS **PORTABLE OUTDOOR SCOREBOARD**

**FAIR-PLAY SCOREBOARDS
DES MOINES, IOWA**

TABLE OF CONTENTS

I. INTRODUCTION

II. FEATURES

- GFCI POWER CABLE,
- POWER REQUIREMENTS
- POWER COMPARTMENT
- SWITCH FUNCTIONS
- CONTROLS
- HORN
- TWO-DIGIT DISPLAY

III. EQUIPMENT SETUP

- LOCATION
- POWERING THE DISPLAY
- CONNECTING OPTIONAL CONTROLS

IV. USING THE PSO-6900-2

- OVERVIEW
- PROGRAMMING AND USING OPTIONAL CONTROLS

V. OPTIONS AND ACCESSORIES

- WIRELESS OPTION
- HORN OPTION
- BATTERY OPTION
 - ❖ CHARGING THE BATTERY
 - ❖ REPLACING THE BATTERY & BATTERY SAFETY

I. INTRODUCTION

Your PSO-6900-2 is a portable, multi-function display that can be used for a variety of sports timing applications from football to water polo. It is designed to meet the needs of high school, college, and professional level facilities. It is powered by plugging into a standard 120VAC-wall outlet, and can also be equipped with an optional 12VDC rechargeable battery, which can provide at least 6 hours of operation on a fully charged, properly maintainrd battery.

This instruction booklet will provide you with information on how to install and operate the PSO-6900-2. A troubleshooting document (doc. # 01-0008-03, referenced in the table of contents) has also been included for your convenience. If further assistance is needed, please contact your local authorized **FAIR-PLAY** representative, or call the **FAIR-PLAY** Service Department using the telephone numbers listed below.

**IF YOU HAVE ANY QUESTIONS PLEASE CALL THE *TRANS-LUX / FAIR-PLAY*
HELP DESK AT:**

TELEPHONE (800) 747-5305 or (800) 462-2716

FAX / MESSAGE (770) 447-8128

**PLEASE VISIT THE *TRANS-LUX / FAIR-PLAY* WEBSITE:
WWW.FAIR-PLAY.COM**

II. FEATURES

GFCI POWER CABLE

Proper grounding of the electrical circuits and display structure is an important safety and operational aspect of any electrical device. The display power cord includes a built-in ground fault circuit interrupt (GFCI) for your protection during outdoor use. Under normal conditions, if an electrical fault is detected the interrupt circuit will break the primary power connection.

Reference **Illustration A** below. Again, under normal conditions when the GFCI power cable is plugged into a correctly wired 120 VAC power source, the POWER INDICATOR LAMP will illuminate. If the lamp doesn't light up, try firmly pressing the RESET button labeled "R". If the lamp still doesn't come on, refer to the troubleshooting document (doc. # 01-0008-06). To test the ground fault circuit, firmly press the TEST button labeled "T". The POWER INDICATOR LAMP should immediately extinguish to indicate a protected circuit. If it doesn't, please contact your local authorized **FAIR-PLAY** representative or call the **FAIR-PLAY** Service Department to arrange for service of the power cable.

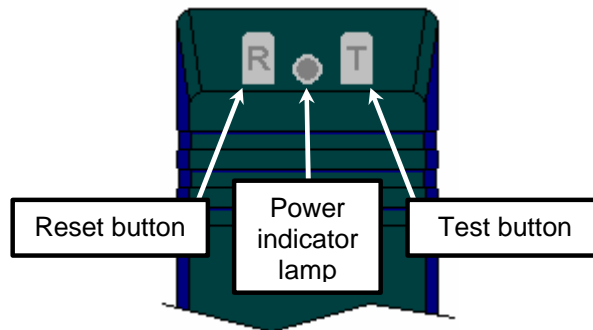

Illustration A

POWER REQUIREMENTS

The GFCI power cable is wired for connection into a standard 120-volt single-phase 2-wire grounded power supply outlet.

An optional factory installed battery** is also available for use as a portable power source with a minimum of 6 hours run time when properly charged and maintained. Recharging the battery requires connection to a standard 120-volt single-phase 2-wire grounded power supply outlet.

**** The battery option is factory installed ONLY ~ retrofit kits are not available!**

POWER COMPARTMENT

Reference the power compartment **Illustrations B1** (non-battery models) and **B2** (battery option models). The power compartment is positioned behind a sliding door located on the back of the display. For access, slide the door upwards using the recessed finger grip. Power compartment components common to both battery and non-battery models include one 120VAC-power cord with built in GFCI, one fuse, and one (1) control connection port.

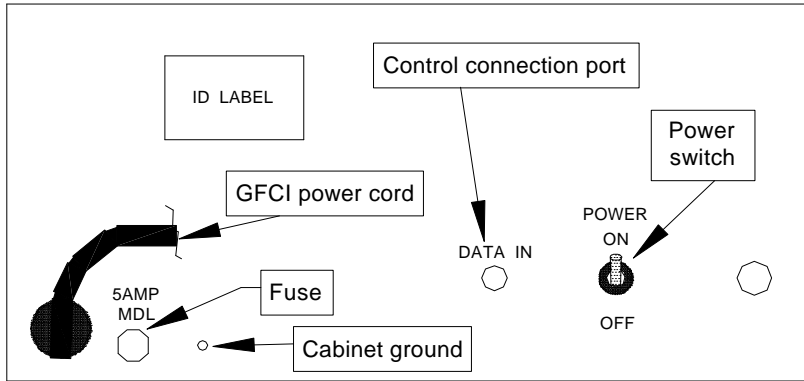

Illustration B1
Without optional battery

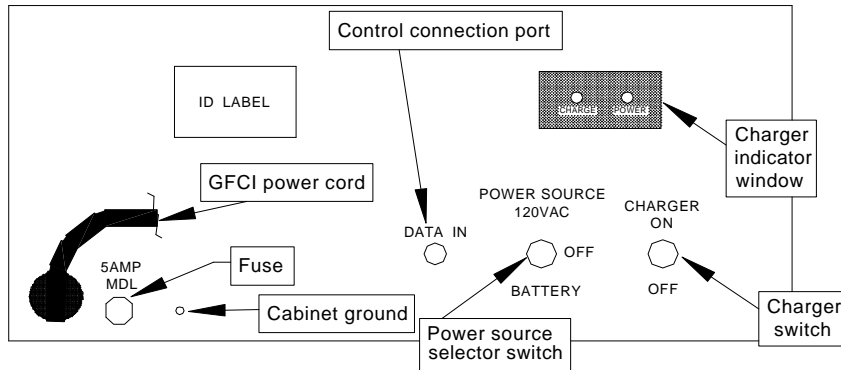

Illustration B2
With optional battery

Additionally, non-battery models of the display have one switch, POWER. Battery powered displays have two switches, CHARGER, and POWER SOURCE. (See **Illustrations B1** and **B2** above, and **Chart A**) Battery option models also have a window to view the charger indicators. Please read **OPTIONS AND ACCESSORIES (SECTION V)** of this manual for complete details about battery care.

SWITCH FUNCTIONS

The POWER switch is installed only in non-battery models and is used to turn the display on and off. In the ON position, 120-volts AC is supplied to the display through the GFCI power cable. The display is de-energized with this switch in the OFF position.

The POWER SOURCE switch is installed only in battery option models and is used to select which type of power will energize the display. This switch has three settings: 120 VAC, OFF, and BATTERY. In the 120 VAC position, 120-volts AC is supplied to the display through the GFCI power cable. In the BATTERY position the internal 12-volt DC battery powers the display. The display is de-energized with this switch in the OFF position.

The CHARGER switch is also installed only in battery option models and is used to turn the built-in battery charger on and off. In the CHARGER ON position, 120-volts AC is supplied to the battery charger. The charger is de-energized with this switch in the OFF position. Please read OPTIONS AND ACCESSORIES (**SECTION V**) for complete details about battery care.

Switch	Setting	Function
POWER (non-battery models only)	ON	Powers the display with 120-VAC.
	OFF	Turns off the display.
POWER SOURCE (battery option models only)	120 VAC	Powers the display with 120-VAC.
	OFF	Turns off the display
	BATTERY	Powers the display with the internal 12-volt battery.
CHARGER (battery option models only)	CHARGER ON	Turns the battery charger on to charge the battery. During the charge cycle the POWER SOURCE switch must be set either to OFF or 120 VAC ~ <u>not BATTERY!</u>
	OFF	Turns off the battery charger ~ battery does not charge.

Chart A

CONTROLS

The display is designed to accept data signals from any one of the following ***FAIR-PLAY*** controls (purchased separately): MP-70-0111, MP-70-0113, MP-50-0111, MP-50-0113, and BB-65. Each of these controls requires the use of a 10-foot control cable, part number C0170, included with the display, or any customer supplied cable length up to 1000'. Reference document ZN-6-A391-3 for cable wiring details. The MP-70-0211 (wireless) and MP-70-0213 (battery powered wireless) controls can also be used with displays that are equipped with the factory installed wireless option. Neither of these controls requires the C0170 control cable. Using any of the above controls, the display can function for numerous timing/scoring applications.

WHEN CONTROL IS NOT IN USE, STORE IT IN A COOL, DRY LOCATION.

DISPLAY

The display features nine ten-inch amber LED digits. They are easy to read, even at a distance or at sharp viewing angles, and are designed for durability and low maintenance.

III. EQUIPMENT SETUP

TRANSPORTATION

The display is equipped with a cart for easy transportation of the scoreboard. A handle has been placed opposite the wheels. Care should be taken to avoid steep grade with the cart. The cart must be placed on level ground whenever the display is not in transit. No one should sit on or place objects on top of the display. **Failure to follow these precautions may result in injury to person or display and may void warranty.**

LOCATION

The display may be positioned to face any direction so that the spectators and the operator can see it. For maximum visibility, place it at a southern or western edge of the field so that the sun does not shine directly on the face of the display during afternoon use. **Position the display in a location that avoids inadvertent contact or injury to athletes and spectators. Take proper precautions to route power and control cables so they can be avoided by athletes and spectators.**

POWERING THE DISPLAY

Plug the GFCI power cable into a standard 120-volt single-phase 2-wire grounded power supply outlet. **The display will not work if it is not plugged in.****

*** Units equipped with the battery option do not need to be plugged in to an AC power source to operate, provided that the battery has been fully charged according to the instructions of **SECTION V (OPTIONS AND ACCESSORIES)** and the **POWER SOURCE** switch is set to **BATTERY**. Optional battery versions can operate with 120VAC power while the battery is charging.*

CONNECTING OPTIONAL CONTROLS

Reference **Illustration D**, next page. Insert the 1/4-inch connector of either end of the C0170 control cable or other customer supplied cable (purchased separately) into either of the Scoreboard data output jacks located on the back panel of the optional control (purchased separately) and firmly push it all the way in. A list of qualified optional controls can be found in **SECTION II** under the heading **CONTROLS**.



Illustration D

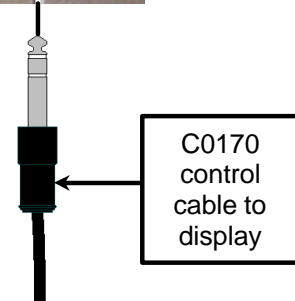

Connect the opposite end of the C0170 control cable into the data connection port in the display's power compartment.

If your PSO-6900-2 is **not equipped** with the battery option, set the power compartment switches to the following positions:

- POWER = ON (GFCI power cable plugged into 120-volt AC power source)

If your PSO-6900-2 **is equipped** with the battery option, set the power compartment switches to the following positions:

- POWER SOURCE = 120 VAC (GFCI power cable plugged into 120-volt AC power source)
– **OR** –
BATTERY (be sure battery is fully charged)
- CHARGER = OFF

IV. USE OF THE PSO-6900-2

OVERVIEW

Set up the system as outlined in **SECTION III** of this manual.

The PSO-6900-2's primary function is that of a portable scoreboard, which allows it to display a four digit game clock, home and visitor scores to 99, and period. In this mode of operation the display will respond to any one of several qualified ***FAIR-PLAY*** controls. The complete display weighs only 50 pounds, (61 pounds with the battery powered option), for ease of portability.

PROGRAMMING AND USING OPTIONAL CONTROLS

For specific details on programming and using optional controls to run the timer feature, refer to the operating instructions for the particular control that you are using to run the PSO-6900-2. A list of qualified optional controls can be found in **SECTION II** under the heading **CONTROLS**.

V. OPTIONS AND ACCESSORIES

WIRELESS OPTION

A factory installed wireless option is available when you purchase the PSO-6900-2. The wireless feature will work only if you are using an optional MP-70-0211 or MP-70-0213 control.

The wireless option consists of a factory installed radio frequency antenna and wireless receiver. For proper operation, the wireless receiver card must be tuned to the same channel setting as the transmitter card contained in the MP-70-0211 or MP-70-0213 controls.

To set the receiver channel, use a small, 1/8-inch slotted tip screwdriver to carefully adjust the 16-position rotary switch to the desired operating channel (located on the RF card inside the access door, adjacent to the lamp driver). Only channels 1 through D are valid, positions E, F and 0 will deactivate the receiver.

For specific details on programming and using wireless MP-70-021X controls refer to the MP-70 user's manual, part number 98-0002-06.

HORN OPTION

A factory installed horn is available when you purchase the PSO-6900-2. The horn will sound when the clock count reaches zero.

BATTERY OPTION

A factory installed battery option is available when you purchase the PSO-6900-2. If so equipped, the PSO-6900-2 will operate for a minimum of 6 hours from a fully charged, properly maintained battery. When the battery is low, the display digit LED's will become noticeably dim and the horn will sound very weak. Charge the battery as soon as possible when the display exhibits these conditions.

CHARGING THE BATTERY

To charge the battery, begin by plugging the GFCI power cable into a standard 120-volt single-phase 2-wire grounded power supply outlet. Next, place the POWER SOURCE switch in the OFF or 120 VAC positions ~ **NOT THE BATTERY POSITION** ~ and place the switch in the CHARGER ON position to charge the battery.

NOTE: The reason for not placing the POWER SOURCE switch in the BATTERY position is that it will take much longer to complete the charge cycle and the extra power drain could potentially damage the internal charger. Place the POWER SOURCE switch in the 120 VAC position only if you intend to use the display while the battery is charging, otherwise it should remain OFF!

During the charge cycle, the charger's amber colored CHARGE and green colored POWER indicators will illuminate. When the charge cycle is complete, the CHARGE indicator will extinguish. At this point, the battery will be fully charged. Place the CHARGER switch in the OFF position and the POWER indicator will extinguish.

Charge cycle durations will vary depending on how much the PSO-6900-2 has been used since the previous charge cycle, and the discharge level of the battery. **Do not leave the PSO-6900-2 on the charge cycle for more than 24 hours!** Regularly look at the amber colored CHARGE indicator in the power compartment's charge indicator window during the charge cycle. If it is no longer illuminated, the charge cycle is complete and the battery is fully charged. You may then place the CHARGER switch in the OFF position and use the PSO-6900-2 as you normally would.

REPLACING THE BATTERY & BATTERY SAFETY

If you need to replace the battery, do the following:

Read the PANASONIC document titled "PRECAUTIONS FOR HANDLING SEALED LEAD-ACID BATTERIES", included in your PSO-6900-2 documentation package.

Make sure the display's GFCI power cable is not plugged into a 120 VAC power source. Place the POWER SOURCE switch in the OFF position. Use a slotted tip screwdriver to remove the two retaining screws holding the bracket inside the PSO-6900-2. Remove the bracket and slide the battery outward, then carefully detach the red and black power cables from the battery terminals. Attach the red battery cable onto the positive (+) power terminal and the black battery cable to the negative (-) power terminals of the replacement battery. **DO NOT CONNECT THE CABLES ONTO THE WRONG TERMINALS AS THIS CAN CAUSE DAMAGE!** Slide the new battery back into the PSO-6900-2. Place the bracket back into position over the battery and secure it with the two screws. Charge the battery as outlined on the previous page once it has been installed.

To order a replacement battery, please contact your local authorized **FAIR-PLAY** representative, or call the **FAIR-PLAY** Service Department using the telephone numbers listed in the INTRODUCTION (SECTION I).

If you are returning a battery for warranty reasons, the outer carton must be labeled "NONSPILLABLE".

PRECAUTIONS FOR HANDLING VALVE-REGULATED LEAD-ACID BATTERIES

Precautions for handling Valve-Regulated Lead-Acid Batteries

- This document should be read in its entirety and its contents fully understood before handling or using Panasonic rechargeable Valve-Regulated Lead-Acid batteries. If there are any questions, please contact Panasonic. Please keep this document available for reference. Due to the potential energy stored in the batteries, improper handling or use of the batteries by not observing the precautions listed in this document may result in bodily injury caused by electrolyte leakage, heat generation, or explosion.

* All descriptions are subject to modification without notice.

Degree of danger

1. DANGER

Indicates an imminently hazardous situation which, if not avoided, will result in death or serious injury.

2. WARNING

Indicates a potentially hazardous situation which, if not avoided, could result in death or injury.

3. CAUTION

Indicates a potentially hazardous situation which, if not avoided, may result in minor or moderate injury, or damage to equipment.

4. RECOMMENDATION

Recommended course of action to prevent a situation that could result in damage of quality, performance or reliability of the batteries, should they be mishandled.

- (Remark 1) Even in cases where lead-acid batteries are handled improperly, a situation that will result in the immediate death of the user is highly unlikely. However, we have assumed the higher DANGER level situation instead of the WARNING and CAUTION levels because the high energy stored in batteries still implies a possibility of extreme hazard which might lead to serious injury.
- (Remark 2) Serious injury here would include injury, loss of eyesight, burns, electric shocks, bone fractures and poisoning that will cause permanent damage or require hospitalization or intensive treatment over an extended period. Minor injury includes slight burns and electric shock. Property damage means damage to buildings and household effects including livestock and pets.
- (Remark 3) RECOMMENDATION refers to the suggested means by which to protect batteries from impaired quality, performance and reliability.

PRECAUTIONS FOR HANDLING VALVE-REGULATED LEAD-ACID BATTERIES-CONT.

Safety Precautions

1. Environment and condition of use

DANGER

- (1) Do not load valve-regulated lead-acid batteries (hereinafter described as "the battery") in airtight equipment. Use of the battery in airtight equipment may cause explosion of the equipment or injury.

WARNING

- (1) Charge the battery using a specified charger or under the charging condition specified by Panasonic. Charging the battery under any other conditions may cause the battery to overheat, emit hydrogen gas, leak, ignite, or burst.
- (2) When using the battery in medical equipment*, provide a back-up system other than the main battery. Failure of the main battery in the absence of a back-up power could lead to injury.
- (3) Avoid direct contact of the battery with metallic containers; acid- and heat-resistant insulators should be employed. Leakage of the battery in the absence of insulators may cause problems such as release of fumes and ignition.
- (4) Do not place the battery near a device that may cause sparks (such as a switch or a fuse). The battery may generate flammable gas when charged, so remember to keep the battery away from fire or an open flame to prevent any sparks from igniting or causing explosions.
- (5) Avoid placing the battery near a heat-generating part (such as a transformer). Using the battery near a heat source may cause the battery to overheat, leak, ignite, or burst.

* The battery should only be used in non life critical medical equipment. When any medical equipment incorporating a Panasonic VRLA battery is planned, please notify Panasonic.

CAUTION

- (1) The operating temperature range for the battery is specified below. Use of the battery at temperatures beyond this range may cause battery damage.
Normal operating temperature of the battery is 77°F (25°C).
When discharged (equipment in use): 5°F to 122°F (-15°C to 50°C)
When charged: 32°F to 104°F (0°C to 40°C)
During storage: 5°F to 104°F (-15°C to 40°C)
- (2) Do not allow the battery to be immersed in or wetted with water/sea-water; as it may corrode the battery, ignite or create an electric shock hazard.
- (3) Do not place or store the battery in an automobile in hot weather, under direct sunlight, in front of a stove, or near fire. Use or storage of the battery in these places may cause battery leakage, fire or bursting.
- (4) Use of the battery in a dusty environment is not recommended, as it may cause the battery to short. The battery should be periodically checked when used in such an environment.

PRECAUTIONS FOR HANDLING VALVE-REGULATED LEAD-ACID BATTERIES-CONT.

- (6) In applications which use more than one battery, first make sure of correct mutual connections between batteries, and then connect the battery with the charger or the load. Make sure to firmly connect the (+) pole of the batteries to the (+) terminal of the charger or load, and the (-) pole to the (-) terminal in the same way. If the poles/ terminals of the batteries, the charger and the load are connected improperly, explosion, ignition or damage to the batteries and/or equipment may occur, causing injury to personnel in some cases.
- (7) Be extremely careful not to drop the battery onto feet to avoid the possibility of serious injury.

2. Installation

DANGER

- (1) Insulate metallic tools such as torque-wrenches and wrenches with a vinyl tape, etc. Using uninsulated tools may cause a short circuit, and the heat or sparks generated by the short circuit could result in burns, damage to the battery, or ignite an explosion.
- (2) Do not place the battery in a closed room or near fire. Placing the battery in such a location could result in an explosion or fire due to hydrogen gas emitted by the battery.

WARNING

- (1) Do not contact any plastic or resin containing a migrating plasticizer* with the batteries. Avoid using organic solvents such as thinner, gasoline, lamp oil, benzene and liquid detergent to clean the batteries. The use of any of the above materials may cause the containers and/or the covers (ABS resin) of the batteries to crack and leak, or could ignite. Avoid using material containing a migrating plasticizer by asking the manufacturer its contents.
- (2) Take safety measures such as wearing rubber gloves for insulation when handling a voltage of 45 V or higher. Operation without safety measures may result in electric shocks to the operator.
- (3) Avoid placing the battery in an environment which is susceptible to floods. There is the possibility that if the battery is immersed in water, it may ignite or cause electric shocks to personnel.

RECOMMENDATION

- (1) Avoid sudden movements or applying shocks to the battery e.g. from dropping the battery. Damage and deterioration of battery characteristics may occur if the battery is dropped.
- (2) Carefully check the life characteristics of the battery when in actual loaded mode. Life of the battery may vary greatly depending on charge/ discharge conditions

CAUTION

- (1) When unpacking the battery, make sure to handle it gently. Rough handling may shock the battery, causing damage. Check that the battery is free from cracks, fractures, tipping and leakage.
- (2) When loading the battery in equipment, mount it in the lower most section of the equipment in order to ensure easy checking, maintenance and replacement. Do not charge the battery in the inverted (upside-down) position: overcharging in the inverted position may cause battery leakage from the safety valve. The inverted position is demonstrated in the far left picture below where the letters "Panasonic" on the battery in the picture are inverted. The following illustrations are for explaining positions of the battery, not for showing accurate configurations for each type of battery.

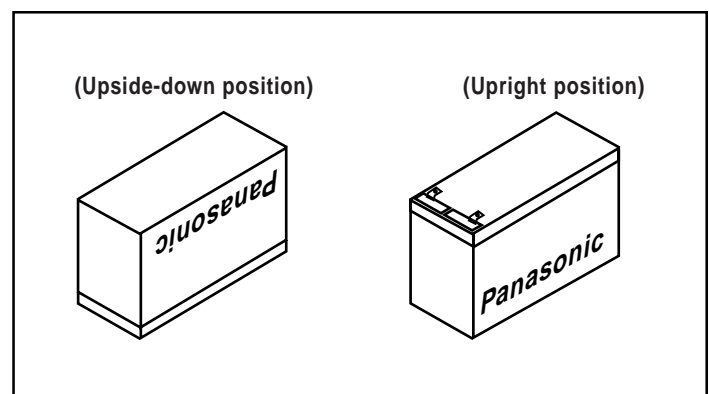

* Examples of plastic or resin to avoid: Vinyl chloride, Oily rubber.
Examples of acceptable types of plastic or resin: Polyolefin resin such as polypropylene or polyethylene.

PRECAUTIONS FOR HANDLING VALVE-REGULATED LEAD-ACID BATTERIES-CONT.

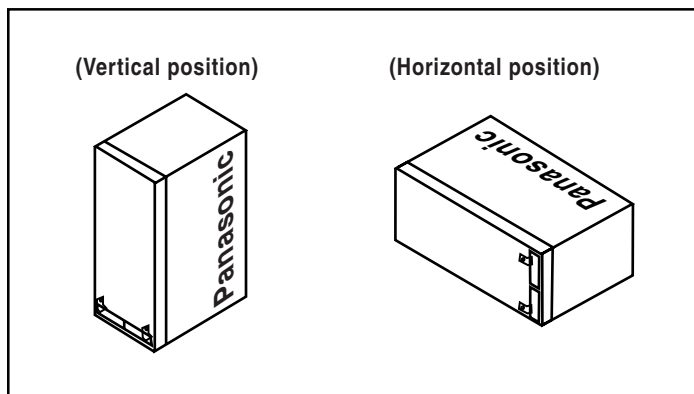

- (3) Do not carry the battery by hanging it from the terminal or the lead wire, as it may cause damage to the battery.
- (4) When carrying the battery, exercise caution not to apply a strong shock to it by dropping it, jarring it or causing it to collide with other objects, as this may cause damage to the battery.
- (5) Do not underestimate the weight of the battery. As it is heavy for its volume, careless handling of the battery may cause backache or other injuries to the operator.
- (6) Do not bring covered wires containing plasticizer or non-rigid PVC sheets in contact with the battery. Do not apply organic solvents such as paint thinner, gasoline, kerosene and benzene or liquid detergents to the battery. When brought in contact with these materials, the battery case may crack, causing leakage of the battery.
- (7) Do not cover the battery with a material which generates static electricity, such as a PVC sheet. A static charge may trigger fire or explosion.
- (8) In fastening bolts and nuts of the battery, observe the torque values specified: otherwise, sparks may be generated and damage of the terminal may occur. The fastening torque of bolts and nuts is as follows:

Bolt (nut) size (mm)			Fastening Torque		
Diameter	Pitch	Length	Nm	kg. cm.	lb. In.
M5 1.197(5)	0.031 (0.8)	0.591± 0.039 (15 ± 1)	2.0 ~ 2.9	20 ~ 30	17.3 ~ 26.0
M6 0.236(6)	0.039 (1.0)	0.7870.039 (20 ± 1)	3.9 ~ 5.4	40 ~ 55	34.6 ~ 47.6
M8 0.315(8)	0.049 (1.25)	0.7870.039 (20 ± 1)	7.8 ~ 9.8	80 ~ 100	69.3 ~ 86.6

- (9) Apply insulation covers to terminals, joint parts, bolts and nuts of the battery in order to prevent electric shocks to personnel.
- (10) When intending to use the battery in vibrating equipment such as motor cycles, engine driven bicycles and engine driven grass shears, please consult Panasonic in advance.
- (11) Fasten the batteries firmly to the equipment to avoid the influence of vibration and/or physical shock.

RECOMMENDATION

- (1) The battery and/or equipment should be installed by skilled personnel (specialists) such as personnel qualified for maintaining battery equipment. Handling of the battery by unskilled personnel may lead to dangerous errors.

PRECAUTIONS FOR HANDLING VALVE-REGULATED LEAD-ACID BATTERIES-CONT.

3. Preparation Prior to Operation

DANGER

- (1) Be sure to provide enough insulation around the lead wires and/or plates used between the batteries and the application. Insufficient insulation may cause an electric shock, heat generating from a short circuit(or excess current) may result in an injury, burn, smoke or ignition.

CAUTION

- (1) Do not connect the battery directly to a power outlet or a cigarette lighter socket of an automobile without using a charger. Direct connection to power sources may cause battery leakage, heating or bursting.
- (2) Turn off the switch of the circuit when connecting the battery to a charger or a load.
- (3) If newly purchased batteries exhibit any irregularities in initial use, such as rusting, heating or other problems, they should not be used. Continued use of an irregular battery may lead to leakage, fire or bursting of the battery.

REQUEST

- (1) Since the batteries tend to lose a part of their capacity due to self-discharge during shipment and storage, recharge the batteries before you use them after purchase or long-term storage in order to restore their full capacity. Check for the following conditions before recharging:

Charging method	Charging condition (at 25°C)
Constant voltage	<ul style="list-style-type: none">• Regulation range of the controlled voltage: 7.25V to 7.45V/6V battery, 14.5V to 14.9V/12V battery;Initial current: 0.1CA to 0.4CA;Maximum charging time: 24 hours.• Short-time charge is possible when several batteries of the same model, under the same storage conditions can be charged in series. Otherwise they can be charged separately.
Constant current	<ul style="list-style-type: none">• Charging current: 0.1CA• Charging time (hours)=[Amount of self-discharge (Ah)/0.1CA] x 120%• Rough estimation of amount of self-discharge is as follows (for an example): When the storage ambient temperature is lower than 25°C, and storage time is known, assume the following amount of self-discharge:[5%/month] x storage months• Multiply this by the rated capacity (at 20 hour rate) of the battery• Regardless of the above calculation, the charge time for a refresh charge must be less than 12 hours.• When the storage ambient temperature is higher than 25°C, please consult Panasonic.

4. Unspecified Use

CAUTION

- (1) Do not place the batteries in an unspecified use or they may leak, ignite, or explode.

PRECAUTIONS FOR HANDLING VALVE-REGULATED LEAD-ACID BATTERIES-CONT.

5. Method of use

DANGER

- (1) The batteries must be charged using the specified charger or by maintaining the charging conditions indicated by Panasonic. If the batteries are charged under conditions other than those specified by Panasonic, they may leak, ignite or explode.
- (2) Do not connect the (+) and (-) terminals of the battery to each other with a metallic material such as wire; do not allow tools such as pipe wrenches and wrenches to touch points of different voltages on the battery; and do not bring metallic necklaces or hair pins into contact with the battery or store them together with the battery. Failure to observe these precautions may cause the battery to overheat, emit hydrogen gas, leak, ignite, or burst.
- (3) For safety, make sure to observe the following: Otherwise, leakage, ignition or an explosion of the battery may occur.
 - 1) Do not charge the battery with its (+) and (-) terminals and the (+) and (-) terminals of the charger connected in reverse.
 - 2) Do not apply a solder directly to the battery terminals. If direct soldering is unavoidable, please contact Panasonic in advance.
 - 3) Avoid mixed usage of batteries differing in type, manufacturer or history of use.
 - 4) Do not remove or damage the outer case of the battery.
 - 5) Do not apply strong shocks or jolts to the battery.
- (4) Do not continue to charge the battery beyond the time specified in the instructions of use of the charger. If the battery is not fully charged even after being charged for a longer time than specified, discontinue charging and remove the battery from the charger. Charging for a longer time than specified may cause the battery to leak, ignite or burst.

WARNING

- (1) Do not throw the battery in fire nor heat the battery. The battery may burst or generate a toxic gas if placed in contact with fire.
- (2) Do not attempt to disassemble, remodel or destroy the battery, as it may cause battery leakage, fire or bursting, and could also create sulfuric acid spills from the battery resulting in possible burns to personnel and damage to the immediate environment.
- (5) Do not discharge the batteries beyond the maximum values indicated in the specifications. If the batteries are discharged beyond the maximum values, they may leak, ignite or explode.
- (6) Children should only use the battery under the guidance of an adult who should thoroughly instruct the child on its use. During use the adult should check that the battery is used exactly as instructed.

CAUTION

- (1) Check the battery for any sign of irregularities in appearance. If there is any damage to the battery case/cover such as cracks, deformation or leakage, replace the battery with a new one. If the battery appears dirty or dusty, clean it. If a battery of irregular appearance continues to be used, decrease of capacity, leakage of electricity, fumes, ignition or other problems may result.
- (2) If any irregularity is found in areas such as the charge voltage and discharge characteristics of the battery, replace it.

Keep the battery beyond the reach of small children. During charging or actual use of the battery, take caution not to allow small children to remove the battery from equipment.

PROPOSITION 65 WARNING

Battery posts, terminals, and related accessories contain lead and lead compounds, chemicals known to the State of California to cause cancer and reproductive harm. Wash hands after handling.

RECOMMENDATION

- (1) The recommended cut-off voltage during discharge depends on the size of the discharge current. The relationship between the storage battery discharge current and the ideal discharge cut-off voltage is described in Panasonic specifications and technical handbooks.
Do not continue discharging to the point where the voltage drops below the recommended discharge cut-off voltage.
If a storage battery that was discharged below the recommended discharge cut-off voltage is recharged, the storage battery may generate heat which could deform it or cause condensation to form on the battery casing due to the evaporation of moisture from inside the battery. Discharging below the recommended discharge cut-off voltage may also accelerate the deterioration of the battery's performance characteristics.
- (2) Avoid overdischarge, and charge the battery immediately after discharge. The instruction manual of the equipment should contain information telling the user not to overdischarge the battery and to charge the battery immediately after the use of the equipment (discharge). Even if discharge of the battery is stopped before voltage decreases to such a level that the battery-driven equipment stops being operational, deterioration of the battery may be accelerated by the so-called sulphation phenomenon if it is not recharged after use. The low voltage cut-off circuit should be designed so that it can completely cut off the discharge current including a weak current.
- (3) If a charge method and a charge condition other than that described in the specification and the technical brochures is to be adopted, charge/discharge characteristics and life characteristics of the battery should be thoroughly checked in advance. The adoption of adequate charge methods and adequate charge conditions are crucial to ensure safe use of the battery and for fully utilizing the battery capacity.
- (4) For the cycle operation of the battery (application of the battery as the main source of power by repeating charge and discharge), use a charger which operates by controlling either the charge period or charge quantity. Continue charging the battery for the time specified or until the charge completion lamp, if provided, indicates completion of charge. If charging is suspended before completion, the service life of the battery may be shortened.
- (5) Avoid parallel charging of batteries in cycle use, as this may shorten the service life of the batteries by causing an imbalance in charge/discharge state among the batteries connected in parallel.
- (6) During trickle or float charge of the battery, measure the total voltage with a high-accuracy voltmeter of Class 0.5 or better. If the voltage readout does not meet the specified value, investigate the reason and take proper measures. A total voltage that is lower than the specified value indicates insufficient charge which may reduce the battery capacity; a voltage higher than specified indicates an overcharge which may shorten service life of the battery or cause problems such as thermal runaway in some cases.
- (7) Make sure to turn off the switch of the battery equipment after use, otherwise excessive discharge may cause deterioration in battery performance and shorten service life.
- (8) When the equipment is not used for a long period, remove the battery from the equipment, charge it fully, and store it in a place where humidity is low. Unsatisfactory storage conditions may cause deterioration in battery performance, shorten service life and could cause rust to form on the terminals.

PRECAUTIONS FOR HANDLING VALVE-REGULATED LEAD-ACID BATTERIES-CONT.

6. Maintenance and checking

WARNING

- (1) Clean the battery with a slightly damp cloth, ensure there is no excess water on the cloth by squeezing it well. Do not use a dry cloth or a duster, as it may cause the battery to generate static electricity, leading to possible ignition and bursting of the battery.
- (2) Replace the battery with a new one within the time period specified in the instruction manual or equipment.
 - Follow the guideline which states the battery should be replaced when its capacity has decreased to 50% of the initial capacity (at an ambient temperature of 77°F (25°C) or below). In the trickle or float application of the battery (application as stand-by power) at an ambient temperature higher than 77°F (25°C), the period for which the battery can be used before replacement is shortened by a half for every 10°C rise of temperature. When the discharge current becomes higher than 0.25 CA, the run time and battery life is also shortened.

- The usable period for the battery is markedly shortened near the end of its service life (when discharge time has decreased to 50% of the initial). This is also the period when battery problems such as internal short, dry-up of electrolyte (increase in internal resistance) and corrosion of the cathode grids will occur. Replace the battery before these conditions are reached: if the battery continues to be used under these conditions, maximum discharge current will continue flowing, which may lead to thermal runaway or leakage.

CAUTION

- (1) Do not apply organic solvents such as paint thinner, gasoline, kerosene and benzene or liquid detergents to the battery. If these are brought into contact with the battery case, it may crack, causing leakage.

RECOMMENDATION

- (1) Keep the terminals of the battery clean. Dirty terminals may cause inadequate contact of the battery to the equipment body, leading to power failure or charge failure.

7. Emergency measures

WARNING

- (1) The battery contains diluted sulfuric acid, a very toxic substance. If the battery leaks and the liquid inside spills on the skin or clothing, immediately wash it off with plenty of clean water. If the liquid splashes into eyes, immediately flush the eyes with plenty of clean water and consult a doctor. Sulfuric acid in the eyes may cause loss of eyesight and acid on the skin will cause burns.

CAUTION

- (1) If any corrosion of the terminals, leakage or deformation of the case of the battery is found, do not use the battery and turn off the power supply. If a battery which is irregular or substandard in any way continues to be used, leakage, fire or bursting of the battery may occur and there is also a potential for electric shock.

PRECAUTIONS FOR HANDLING VALVE-REGULATED LEAD-ACID BATTERIES-CONT.

8. Storage

CAUTION

- (1) Store the battery in a stable position so as to keep the terminals of the battery away from any metallic or other conductive material (including items that may fall or drop onto the battery).
- (2) Protect the battery from rain. If the terminals of the battery come into contact with water, they may corrode.
- (3) Keep the battery in the upright position as a general rule, and do not apply abnormally strong vibrations or shocks to the battery. Transportation of the battery in an abnormal position or the application of abnormally strong vibrations or shocks to the battery may cause damage to the battery and the deterioration of characteristics.
- (4) When storing the battery, remove it from the equipment or disconnect it from the charger or the load and keep it in a place where temperature is low. Do not store the battery under direct sunlight or in high temperatures (140°F (60°C) or higher) or in a highly humid atmosphere, because rusting, deterioration of performance and life of the battery may occur.

RECOMMENDATION

- (1) During storage of the battery, charge it at least once every six months (when ambient temperature is 77°F (25°C) or below). Shorten the interval of charging to a half by every 50°F (10°C) rise of ambient temperature. The rate of self discharge of the battery doubles for each 5°F (10°C) rise of ambient temperature. If the battery has been stored for a long period in a discharged state, it may not be able to regain its capacity even if it is recharged.
- (2) If the battery is stored for a year or longer without being charged, its service life may be shortened.
- (3) Store the battery after fully charging it, otherwise its service life may be shortened.
- (4) Use the battery as soon as possible. The battery gradually deteriorates during storage and thus its decreased capacity may be irreversible even allowing when recharged.

9. Disposal of batteries

CAUTION

- (1) In countries where there are legal or voluntary regulations on the recycling of rechargeable batteries, please provide written information on recycling of rechargeable batteries with the equipment, packaging, instruction manuals, etc.
- (2) Adopt methods and measures for equipment design and battery mounting that will allow for easy removal of batteries for replacement and disposal.
- (3) Used batteries are recyclable. When returning used batteries, insulate their terminals with adhesive tapes, etc., otherwise the residual electricity in used batteries may cause a fire or explosion.
- (4) This battery is fully recyclable and should be accepted at any location that accepts common automotive starter batteries. Examples of places that accept these batteries are: County or municipal recycling drop-off centers, scrap metal dealers, and retailers who sell automotive replacement lead acid starter batteries. In North America, non-consumers can call 1-800-SAV-LEAD for assistance in recycling.

Refer to the SAV-LEAD section in the back of this handbook for complete instructions.

SCOREBOARD CARE – OFF SEASON

EL-1527

FAIR-PLAY SCOREBOARDS DES MOINES, IOWA

Your Fair-Play scoreboard, when installed as directed by the installation instructions, is designed and constructed to withstand normal environmental conditions. Because of its seasonal usage, particularly outdoor football and baseball scoreboards, long life with minimum service can be expected by caring for the scoreboard during off-season.

OFF-SEASON PREVENTATIVE MAINTENANCE PROCEDURES CAN INCLUDE:

- 1.) Small scoreboards and portable scoreboards can be disconnected and removed from their supports and stored in an indoor location.
- 2.) Controls should be unplugged, placed in their carrying cases and stored in a dry location of moderate temperatures.
- 3.) The processors in outdoor scoreboards will benefit by their removal and storage in a dry location of moderate temperature. When left in the scoreboard they are subject to vandalism and damage from various types of weather, including lightning.

IF IT IS NOT PRACTICAL TO REMOVE THE PROCESSOR, ITS POWER AND CONTROL CONNECTORS CAN BE UNPLUGGED TO ISOLATE IT FROM EXTERNAL ELECTRICAL SOURCES. WHEN UNPLUGGING CONNECTORS, BE SURE EACH IS MARKED WITH A NUMBER OR TAPE TO INDICATE ITS CORRECT SOCKET POSITION. DRAPE THE CABLE HARNESS UP SO THE CONNECTOR DOES NOT LIE ON THE BOTTOM OF THE SCOREBOARD COMPARTMENT.

- 4.) The scoreboard equipment should be inspected, reassembled, and tested well before the first game of the season to allow sufficient time for the return and repair of any malfunctioning parts.

CAUTION

SERVICE THE SCOREBOARD ONLY AFTER IT IS DISCONNECTED FROM ITS POWER SOURCE.

Fair-Play

A TRANS·LUX® COMPANY

TROUBLE SHOOTING PORTABLE DISPLAYS

Problem:

Display does not light or function.

Solution:

1. Check display GFI breaker.
2. Make sure connectors on processors are seated properly.
3. Check power at the display. If there is no power at the display, call an electrician.

Random LED's, display not functioning correctly.

1. Check to see if the controller is operating properly. Check power at the controller location. Check data cable plug and connectors.
2. Plug the controller into the data in on the processor located in the scoreboard. If the scoreboard runs, you need to replace the data cable.
3. Install spare processor, if this works send in old processor for repair.
4. If the above steps don't work, send in the controller for repair.

Miscellaneous LED's not lighting or staying lit all the time

1. If a complete digit is not working, check the connector on the processor and the digit.
2. If a single LED is not lighting, change the entire PCA card.
3. If LEDs are staying lit, install spare processor or call authorized Fair-Play dealer.

Fair-Play

A TRANS-LUX® COMPANY

**TRANS-LUX MIDWEST CORPORATION
d.b.a. Fair-Play Scoreboards**

LIMITED SCOREBOARD WARRANTY

Fair-Play provides a limited five-year warranty when its permanently mounted scoreboards and scoreboard controllers are operated and maintained according to the owner's instructions furnished with the equipment. Such limited warranty is two years for portable scoreboards. This warranty covers all electronic components, including LEDs, for five or two years as applicable from the date of invoice that prove to be defective in material or workmanship. Our #161 and #655-type indoor lamps are warranted on a ten-year factory exchange basis from the date of invoice.

Warranted for one year are mechanical control panel switches, connectors, horns and visual goal indicators. Wireless control components are warranted for two years. Wireless control devices even if not defective may not function reliably in certain environments or otherwise due to outside causes beyond Seller's control, including but not limited to cell phones or portable computers. In the event it is determined a wireless device during the ninety (90) day period following shipment does not function in accordance with its specification without repeated errors or is otherwise consistently unreliable, and Seller determines repair or replacement thereof is not likely to improve performance, at Purchaser's request, upon return to Seller postage prepaid in like new condition within such time period, Seller's sole obligation shall be to refund the entire purchase price of such device. Thereafter Seller's sole obligation shall be to repair or replace, other non-wireless defective components for the balance of the warranty period without responsibility or liability for claims for unreliable performance not due to defects. Batteries, battery packs and battery recharging equipment are warranted for thirty (30) days, except for defects arising from misuse, abuse, negligence or other exclusions set forth below. In no event will Fair-Play have any obligation for any damage caused by defective batteries, battery packs and battery recharging equipment. Also warranted for 30 days are outdoor portable scoreboard carts.

Fair-Play's sole obligation during the applicable warranty period is to repair or replace any defective items. Defective assemblies or components are to be returned postage prepaid to Fair-Play's service center, after obtaining a return authorization number, for repair or replacement at no cost to the owner during the applicable warranty period. Replacement parts may be either new or like-new. Return shipping costs after repair will be paid by Seller except for overnight, express or special shipping costs which shall be paid by Purchaser.

Excluded from this warranty are fuses, major components provided by other manufacturers including, but not limited to, computers, rotating signs, power distribution panels, disconnect switches and components of rear-illuminated or lighted signs. The other manufacturer's warranty will apply to such components. Also excluded from this warranty are electronic signs or message centers and related controls. These items are covered by their own specific warranty.

THIS WARRANTY IS IN LIEU OF ALL OTHER WARRANTIES OF SELLER, EXPRESS OR IMPLIED, AND, EXCEPT TO THE EXTENT HEREIN PROVIDED, SELLER DOES NOT MAKE ANY WARRANTY WHATSOEVER INCLUDING, WITHOUT LIMITATION, ANY WARRANTY OF MERCHANTABILITY OR FITNESS FOR ANY PARTICULAR USE OR PURPOSE.

Fair-Play shall not be liable for any incidental, special or consequential damages nor any other loss that may arise in connection with its warranted equipment or any claims under this warranty. (Individual states may have limitations on the length of implied warranties.)

This warranty does not cover shipping damages or problems which result from improper installation of your equipment. (Promptly inspect shipment for visible or concealed damages and report immediately to the delivering carrier.)

Under no circumstances shall this warranty apply if the warranted products have been subject to abuse, misuse, neglect, sabotage, acts of terrorists, negligence, accident, or any casualties or abnormal conditions, including without limitation fire, civil disorders, war, flood, lightning or acts of God. Nor does this warranty cover labor or damage resulting from, or problems caused by, any repair, alteration, modification, or adjustment of the warranted scoreboard(s) or components not performed by Fair-Play.

This warranty extends only to the original purchaser of the warranted products, and is not transferable. For information on extended warranties contact your Fair-Play dealer. In the event authorized Fair-Play dealers make extensions to or provide additional service for Fair-Play products, Fair-Play assumes no liability therefore other than the specific warranty set forth above in this Limited Warranty.

Fair-Play Scoreboards - A Division of Trans-Lux Midwest Corporation
For Service contact: Trans-Lux Repair Center, 110 Richards Avenue, Norwalk, CT 06854
Telephone: 800-462-2716 Fax: (203) 831-8827
Internet Address - www.fair-play.com

Effective 0518-04 © 2004, Fair-Play Scoreboards, All rights reserved.