

Experts in Computational Fluid Dynamics



TotalSim Background

- TotalSim is an independent CFD consultancy firm specialising in aerodynamic and hydrodynamic design and development through the use of open source computational methods.
- TotalSim was established in 2007 by the current managing director Dr Rob Lewis. TotalSim was a natural replacement for the successful Advantage CFD (established in 1998) which was part of the Honda Formula 1 team until 2006.
- TotalSim is based in Brackley, Northamptonshire. We currently employ 16 people in the UK and the company is largely employee owned. We have sibling offices in the USA and Italy, sharing business models and intellectual property.
- TotalSim has over 100 years of combined CFD experience in the automotive and motorsport industry. We are experts in the use of CFD.
- TotalSim has designed and developed race cars in nearly all forms of racing categories, ranging from Formula 1 cars to Le Mans Prototypes, GT sportcars and many more.
- TotalSim also has extensive experience in road car development helping several large road car manufacturers with product development and support.
- TotalSim are world leaders in the use of the open source CFD solver OpenFOAM®* for automotive and motorsport applications. We work closely with the lead developers of OpenFOAM® to generate new codes and improve existing methods.
- TotalSim can also provide support for those wishing to run their own CFD programmes. We offer support packages sharing all of TotalSim's methodologies and codes focused around OpenFOAM®.
- TotalSim has developed its own custom built high performance computing system, giving access to over 850 CPU cores. TotalSim can supply hardware based around our own bespoke low cost recipe, purposely built for CFD.
- In summary, TotalSim can provide cost-effective CFD solutions, systems, training and support within a rigid timeframe and budget.

*OPENFOAM® is a registered trademark of OpenCFD Limited, the producer of the OpenFOAM software.
This offering is not approved or endorsed by OpenCFD Limited, the producer of the OpenFOAM software and owner of the OPENFOAM® and OpenCFD® trademarks.

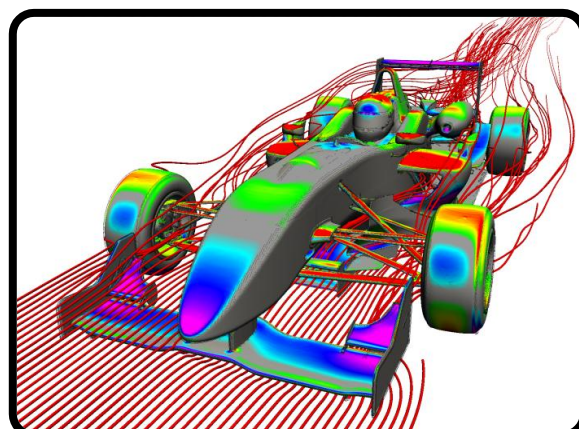
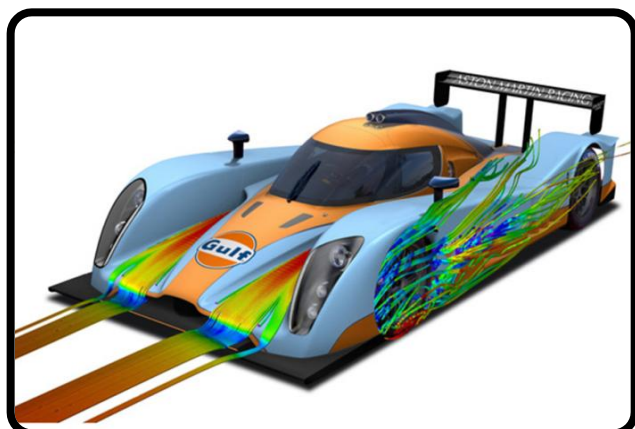



Image courtesy of Swift Group Limited.

Aerodynamic Development

- TotalSim are experts in aerodynamic design and development of automotive vehicles. We have led numerous development programmes working on conceptual designs and prototypes through to full production road and race cars.
- TotalSim can provide complete aerodynamic analysis of external and internal flows. We can quickly evaluate key aerodynamic data such as drag, downforce, balance and cooling flows.
- TotalSim has developed a highly efficient and refined CFD process that allows for rapid turnaround of results. Full car simulation from CAD to first solution can typically be completed in less than 1 week.
- TotalSim has the resources to conduct a large number of CFD simulations concurrently, allowing for rapid aerodynamic development.
- TotalSim can optimise individual components using advanced multi-parameter optimisation techniques coupled with CFD morphing technology.
- TotalSim has consistently delivered performance gains seen computationally to the track. Several of our clients now go directly from CFD to track testing, removing the need for expensive wind tunnel testing.





Optimisation

- TotalSim are at the forefront of multi-parameter optimisation techniques and CFD morphing technology. We are capable of running hundreds of design iterations within a given design space both quickly and efficiently.
- TotalSim's unique optimisation process uses a combination of sophisticated mesh deformation tools and advanced kriging routines. Our process has been developed and refined over many years to create a robust and proven development tool.
- Key to our optimisation process is Sculptor® (www.gosculptor.com), a powerful yet flexible mesh deformation tool. Sculptor® can rapidly morph a processed CAD model into an infinite number of variations, reducing the need for complex and time consuming CAD updates and saving significant time and money. TotalSim are resellers of Sculptor® in the UK.
- Our optimisation process allows multiple geometric parameters to be optimised against multiple performance functions. This may be as simple as a wing angle optimisation or as complex as simultaneous changes in camber, twist, thickness and chord length of a multi-element wing. Optimisations can be performed at multiple attitudes and flow conditions and traded off against each other, to maximise car performance at different tracks.
- In summary, TotalSim's optimisation process will maximise product performance, using an efficient and cost-effective solution in the quickest time possible.

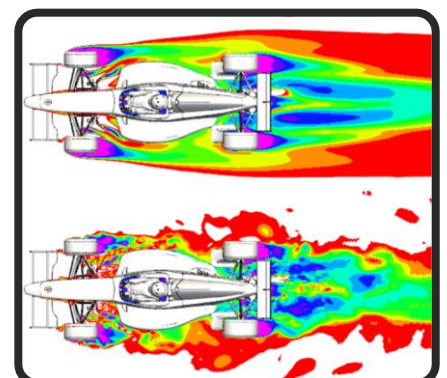
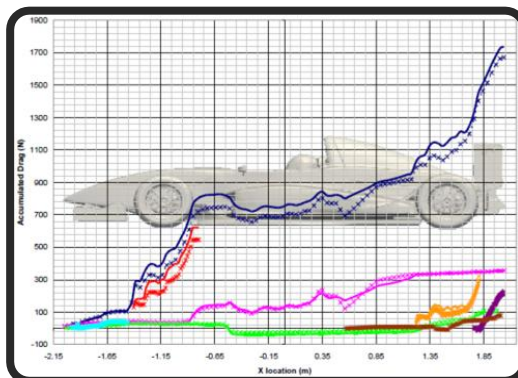
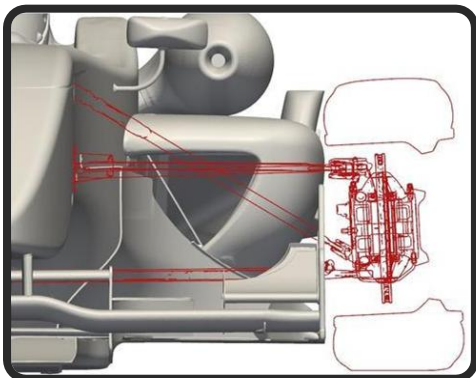

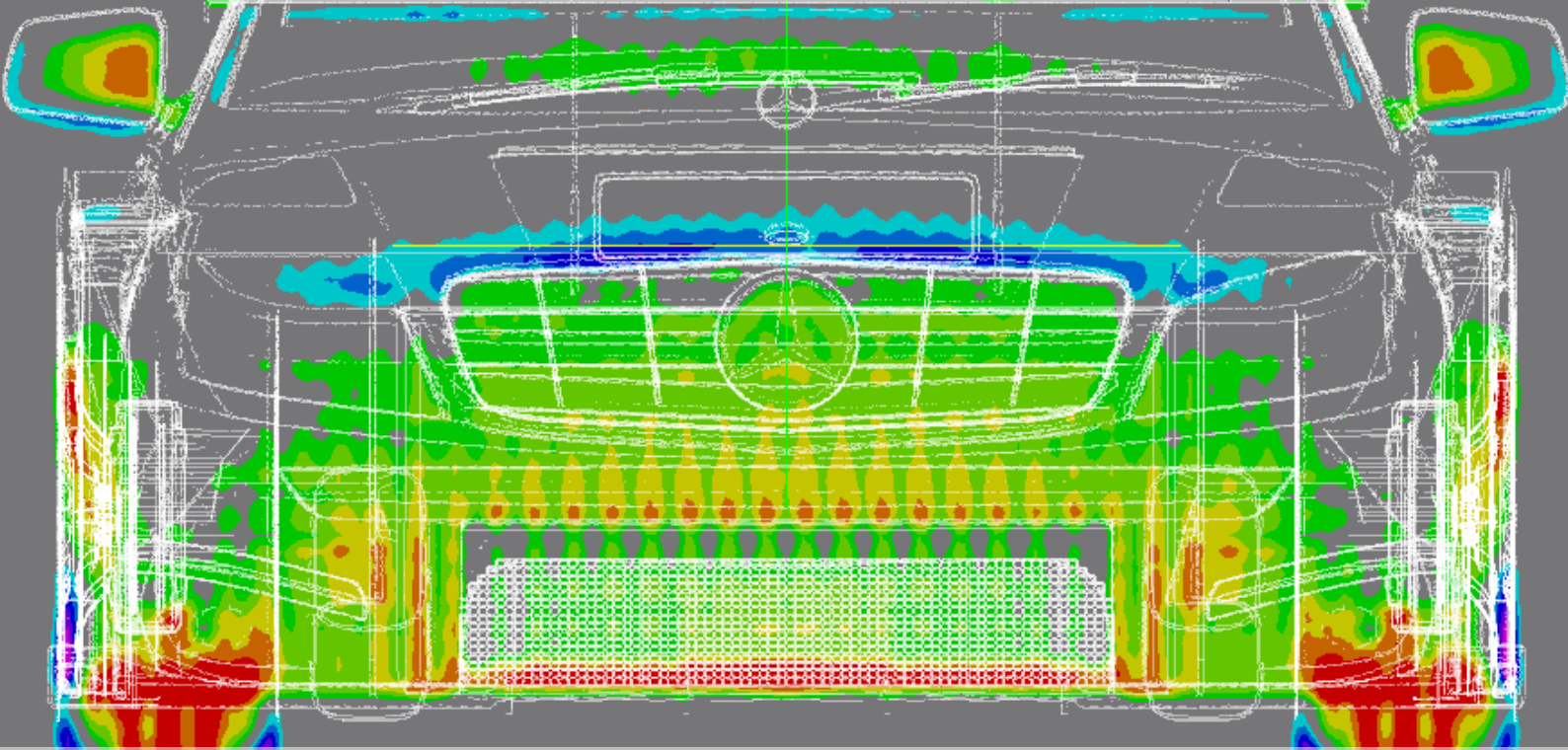

Performance Mapping

- TotalSim has the ability to map the aerodynamic performance of vehicles over a range of:
 - Ride heights (include roll, pitch, steer and yaw)
 - Speeds
 - Wing angles
 - Gurney heights
- TotalSim's bespoke performance mapping tools are quick to setup, fully automated and allow for rapid turnaround of CFD results.
- Performance mapping tools are designed to manipulate the pre-processed CFD model without the need for complicated and time consuming CAD model updates.
- In particular, TotalSim has developed a sophisticated 'Ride Height Changer' tool which can automatically update the geometry of the CFD model based on a given ride height setting.
- 'Rider Height Changer' applies kinematic translations and rotations on suspension and wheel components to accurately represent the orientation of the real life vehicle undergoing roll, pitch or yaw.
- 'Rider Height Changer' is highly flexible, allowing the user to specify front and rear ride heights, roll, yaw and steer. This can all be automated for a number of flow conditions.

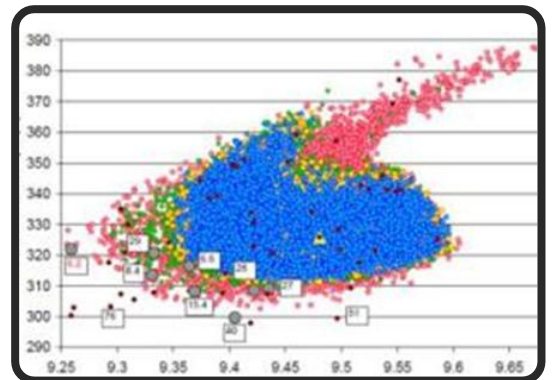
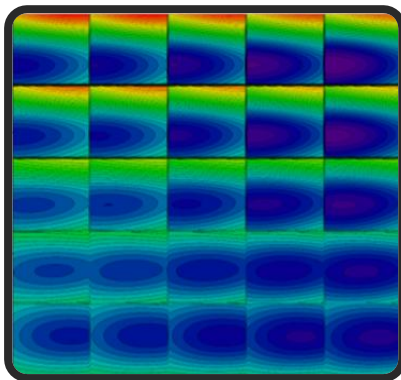
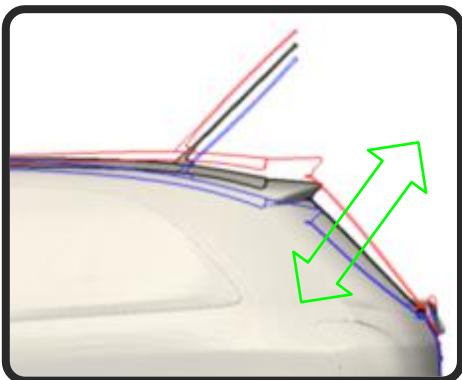

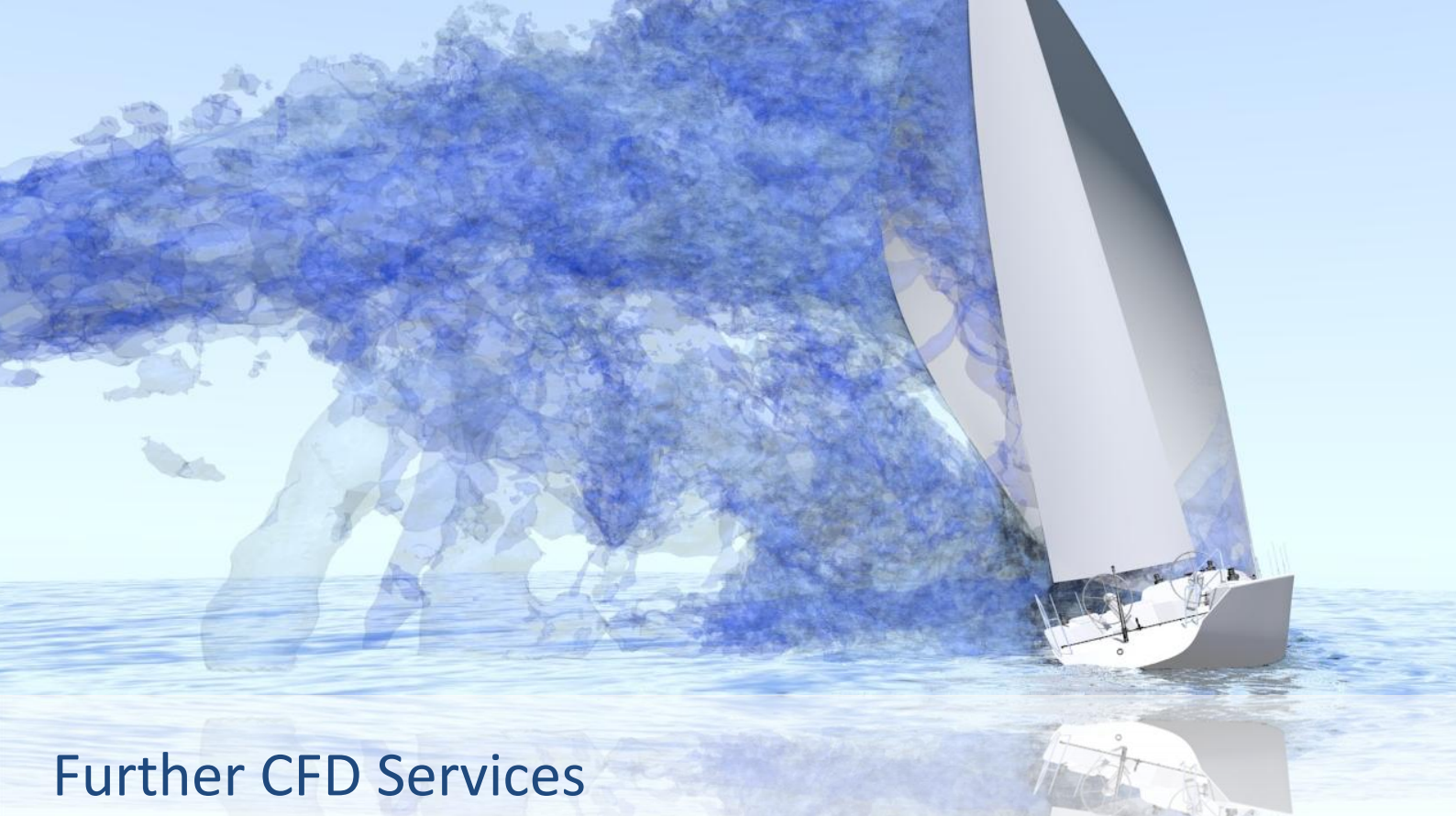

Further CFD Services

- TotalSim's knowledge and expertise is not just limited to CFD based development of external vehicle flows. We have extensive experience in solving a multitude of complex engineering problems.
- Examples include:
 - Internal flow – Modelling of flow inside engine bays and cabins,
 - Cooling flows – Maximising cooling flow to radiators and brakes,
 - Exhaust flows – Modelling of flow from the engine exhaust gases,
 - Thermal modelling – Modelling of heat rejection from brakes and exhausts,
 - Engine intake development – Maximising the efficiency of engine intakes and airboxes,
 - Cabin and ventilation flows,
 - Compressible flows,
 - Multiphase flows,
 - Noise modelling,
 - Free surface modelling – Moving mesh models with multiple degrees of freedom.
- TotalSim also have experience in the environmental, marine, oil and gas industries. This knowledge all adds to the toolbox when complex engineering decisions need to be made.

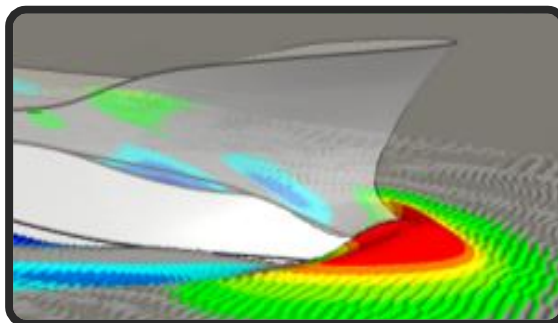
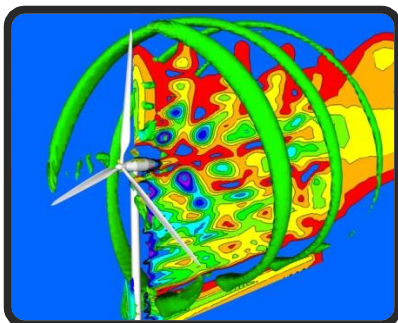
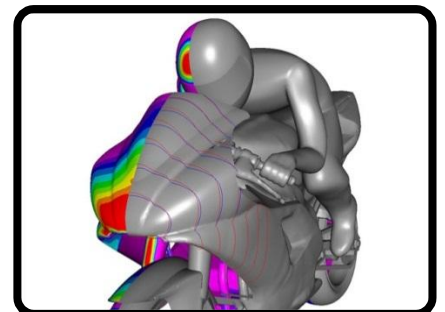
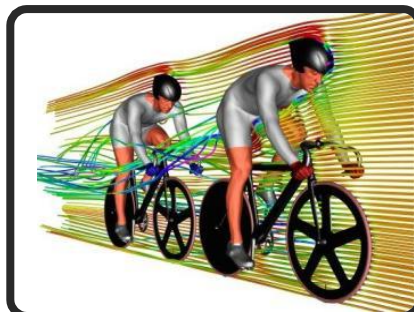
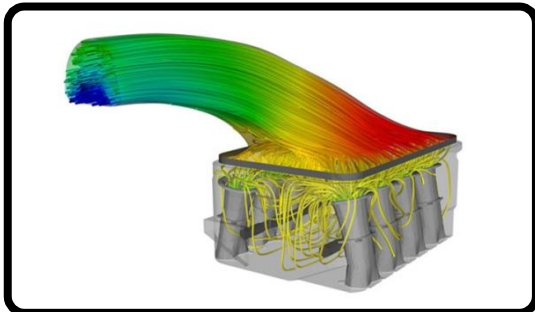

Support Contracts

- TotalSim also offer support contracts for those wishing to:
 - Setup and develop their own CFD capabilities,
 - Get expert training and support in OpenFOAM®,
 - Get bespoke TotalSim codes and tools to help increase productivity.
- TotalSim's open philosophy means we will freely share all our methods, all our software and all our hardware solutions. We help you with everything you need to start up from scratch as a support customer.
- TotalSim also provide expert training in all areas of OpenFOAM® usage, from pre-processing right through to post-processing. We are happy to provide this onsite or at TotalSim's office.
- A CFD solution is only the start point in developing a product. TotalSim can guide you in how to use CFD to develop a design.
- Support contacts include a fixed number of support hours that can be used for:
 - Training,
 - Installation support,
 - General OpenFOAM® usage,
 - Advice on best practise and methodologies,
 - Code development and testing.
- Support contracts also include phone and email support for the whole process so you can get help on demand.
- TotalSim works closely with the lead developers of OpenFOAM®. If you require bespoke functionalities or development of codes, we can make it happen.

Hardware

- TotalSim builds and maintains its own high performance, low cost, low power consuming computing system purposely built for CFD. This allows us to maintain a flexible and cost effective approach to CFD modelling.
- We have access to over 850 CPU cores locally, giving us exceptional computational resources, in addition to access to other supercomputers worldwide.
- TotalSim are happy to share its hardware systems and solutions with our clients. We can help you build, install and maintain your own high performance computing environment.
- Our clusters utilise the latest generation of quad core i7 CPUs. Processors are connected using Infiniband to give high throughput, low latency, yet scalable performance.
- The clusters are custom built using off the shelf components and assembled in a compact bespoke cabinet.
- TotalSim also provide technical support for installation and maintenance of hardware systems.
- Further details on the latest specifications and prices are available upon request.

References

TotalSim have experience in nearly all forms of motorsport including:

- F1
- F3
- GT sport cars
- Karting
- Le Mans Prototypes
- WRC
- GP2
- GP3
- Nascar
- Indicar
- MotoGP
- Historic racing
- SuperGT
- WTCC
- BTCC

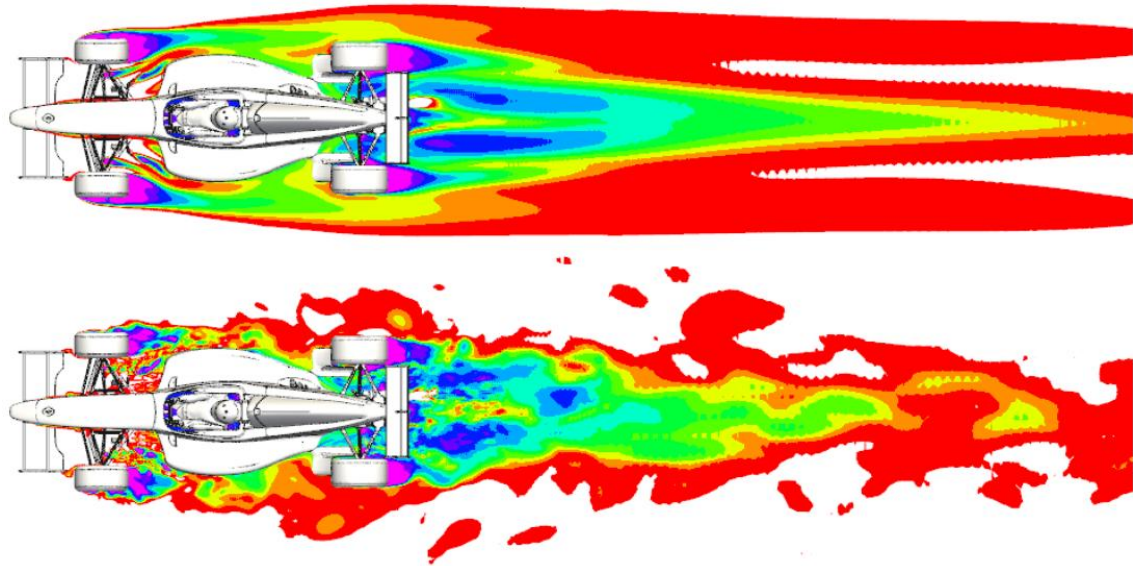

What our clients say about us:

"A great aero development partnership, we are in the 6th year of working together!"

George Howard-Chappell, Prodrive.

" TotalSim have consistently proven to be one of the most creative and innovative organisations we have a partnership with. "

Dr Scott Drawer, Head of Research & Innovation, UK Sport.

" TotalSim have time and again provided the Wolfson Unit with accurate and instructive computational models of real engineering problems."

Sandy Wright, Wolfson Unit.

Contact Details

If you have any questions or queries, please do not hesitate to contact us.

TotalSim Ltd - UK

Top Station Road
Brackley
Northants
United Kingdom
NN13 7UG

Tel : +44 (0)1280 840316

Email : info@totalsim.co.uk

Website: www.totalsim.co.uk

