

VENT-O-MAT[®]

SERIES RBXc

**“ANTI-SHOCK” AIR RELEASE AND VACUUM BREAK VALVES
FOR EFFECTIVE AIR RELEASE VACUUM PROTECTION AND
SURGE ALLEVIATION**



DFC
DYNAMIC
FLUID CONTROL

VENT-O-MAT[®]

AIR RELEASE AND VACUUM BREAK VALVES SERIES RBXc “ANTI SHOCK”

The Unique defence against pipe bursts and pipeline system damage!

Vent-O-Mat Series RBXc has evolved from a long lineage of research and development into a product that has proven unsurpassed for air release, vacuum protection, surge alleviation and pipeline flow enhancement.

The basis of the Vent-O-Mat design is in the understanding of the physical laws that govern air valve and pipeline operation. Reaction to pipeline dynamics is therefore instantaneous and protection provided is relevant to the pipeline's needs.

Vent-O-Mat Series RBXc truly represents the pinnacle of valve design evolution. This valve design provides the most comprehensive, effective and efficient pipeline protection relative to initial cost of any other available pipeline component. This can easily be gauged from the below:

Automatic Surge Protection

The unique Series RBXc valve incorporates as standard, three design features to automatically protect a pipeline, under all pipeline operating conditions, from the destructive surge and water hammer phenomena. These features are independent of any mechanical devices ensuring reaction in a very low millisecond time span.

Effective Air Release

The RBXc design ensures effective de-aeration under all pipeline flow and operating conditions, via either one of three discharge orifices.

Vacuum Protection

The RBXc series large orifice diameters equal the nominal size of the valve. This ensures the least possible resistance to the intake of air and consequently the least possible negative pressure within a draining pipeline. The use of solid, cylindrical floats ensures instantaneous reaction, discourages the "Venturi" phenomenon and is a further guarantee of effective vacuum protection.

Guaranteed Performance

The RBXc has been designed and developed to provide the optimum usable and safe performance relative to all functions. Selection data has been substantiated through third party testing and can therefore be confidently referenced.

The surge protection function of the RBXc design has been incorporated in the well-known **SURGE 2000** surge analysis software programme and can be analysed with great accuracy in other commercially available surge analysis programmes such as FLOWMASTER and TRANSAM.

Unparalleled Service

Vent-O-Mat is committed to customer service and to the selling of solutions. Our highly dedicated team is available at all times to assist with air valve sizing and positioning. Assistance is also provided in finding the most cost effective and/or efficient surge protection strategy relevant to the pipeline's needs.

International Representation

Vent-O-Mat is represented in the following countries and regions:

- | | | | | |
|------------------------|------------|----------------|---------------|-------------|
| * USA | * Thailand | * South Africa | * Namibia | * Kuwait |
| * Canada | * Germany | * Zimbabwe | * Hong Kong | * Brazil |
| * Carribean | * Kenya | * Tanzania | * Taiwan | * France |
| * United Arab Emirates | * Egypt | * Malawi | * New Zealand | * Singapore |
| * South America | * UK | * Zambia | * Vietnam | * Australia |

CATALOGUE INDEX

Introduction	1
Recommended Installation Arrangements	2
Operation	3
Available Discharge Connections	4
Component Description & Material Specifications DN25 (1") & DN50 (2") - Screwed	5
Component Description & Material Specifications DN25 (1") & DN300 (12") - Flanged	6
General Specifications DN25 (1") & DN50 (2") - Screwed	7
General Specifications DN25 (1") & DN300 (12") - Flanged	8
Small Orifice Discharge Performance	9
Selection & Positioning - Series RBXc	10-12
Surge & Waterhammer Protection	13-14
Purchase Specifications	15
Ordering Guide & Test Specification	16

Introduction

- **"ANTI - SHOCK" - "ANTI - SURGE"** - The RBXc is the only air release valve available that is supplied as standard with a mechanism which operates automatically to prevent pipeline damage from the high induced pressure transients associated with high velocity air discharge. Surge resulting from liquid column separation and liquid oscillation is dramatically reduced as an automatic function of this mechanism.
- **PERFORMANCE** - The RBXc has been designed and developed to provide the optimum usable and safe performance relative to all functions. Selection data has been substantiated through CSIR* and other testing and can therefore, be confidently referenced.
- **QUALITY** - The RBXc economically offers the highest quality construction and materials available in an air release and vacuum break valve. Stringent manufacturing and test procedures are maintained to ensure the best possible service and reliability is given by every valve produced.
- **SERVICEABILITY** - The RBXc design facilitates extreme ease of service and maintenance. Components are in corrosion free materials to allow problem free disassembly and reassembly even after many years of operation. All maintenance spares are replaceable without special tools or skills.
- **VACUUM BREAK** - The RBXc series offers large orifice diameters equal the nominal size of the valve, i.e., a 200mm (8") valve has a 200mm (8") orifice. This ensures the least possible resistance to the intake of air and consequently the least possible negative pressure within a draining pipeline.
- **COMPACTNESS** - Although extremely robust the RBXc valve's lightweight and compact construction offers handling transport and installation advantages.
- **BACK UP** - Vent -O- Mat provides highly committed customer orientated sales, service, spares and technical back up - TRY US!!!

* Council for Scientific and Industrial Research

RECOMMENDED INSTALLATION ARRANGEMENTS

TYPE 1

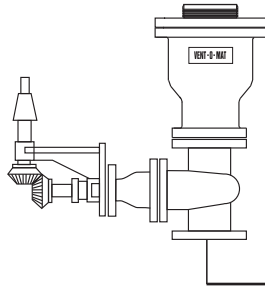

TYPE 2

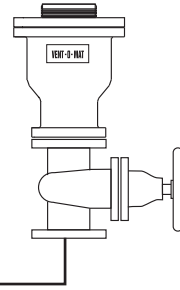

THE DEGREE OF TOLERANCE ALLOWED FOR THE EFFECTIVE OPERATION OF A VENT-O-MAT AIR RELEASE AND VACUUM BREAK VALVE IS **3 DEGREES FROM VERTICAL**

TYPE 3 (Screwed)

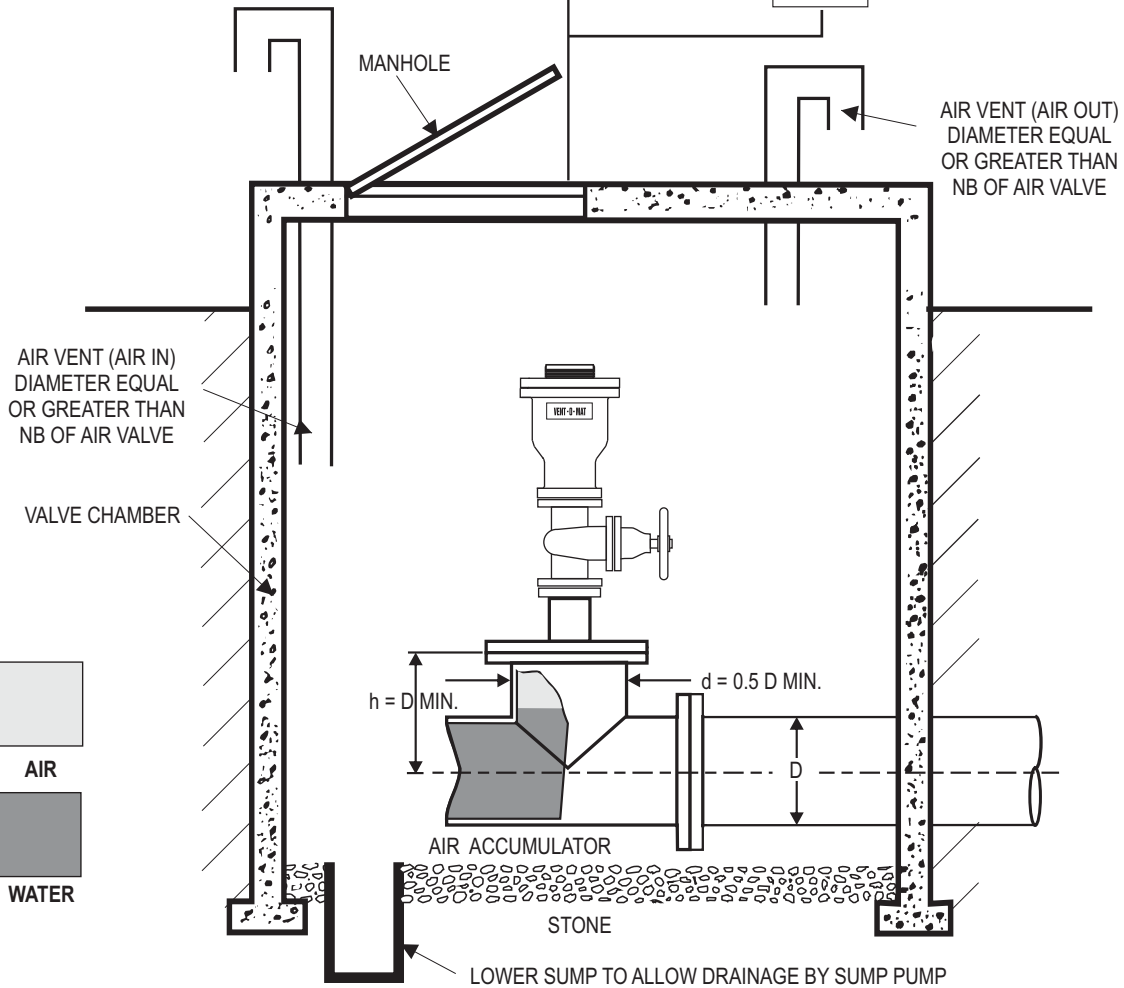
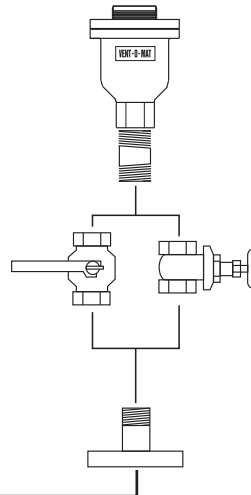

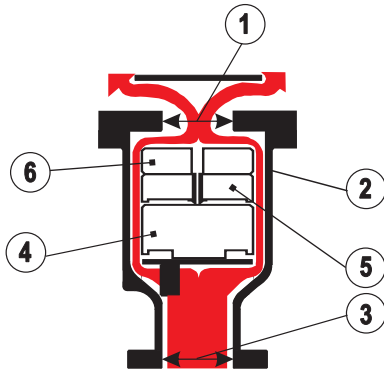

1

VENTING OF A FILLING PIPELINE (SUB CRITICAL WATER APPROACH VELOCITY)

Air enters Orifice (3), travels through the annular space between the cylindrical floats (4), (5), and (6) and the valve Chamber B arrel (2) and discharges from the Large Orifice (1) into atmosphere.

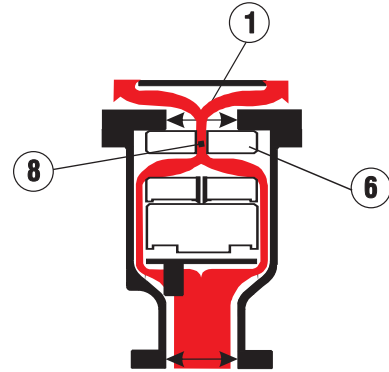

2

VENTING OF A FILLING PIPELINE (EXCESSIVE WATER APPROACH VELOCITY)

In reaction to increased air flow, Float (6) closes Large Orifice (1) and air is forced through the Anti Shock Orifice (8) resulting in deceleration of the approaching water due to the resistance of rising air pressure in the valve.

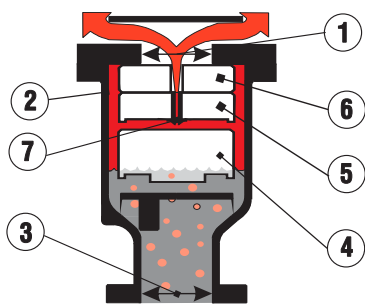

3

PRESSURISED AIR RELEASE FROM A FULL PIPELINE

Subsequent to the filling of a pipeline, liquid enters the valve Barrel Chamber (2) and the Floats (4), (5) and (6) are buoyed so that the Large Orifice (1) is closed by Float (6). The valve will then become internally pressurised. A minimal working pressure of < 0.5 bar (7.3 psi) acting on the relatively large area of the Orifice (1) will lock Float (6) into the closed position across the Large Orifice (1).

Disentrained air rises through the liquid and accumulates in the valve chamber. When the volume of air is sufficient to displace the liquid, Float (4) will no longer be buoyant and will gravitate downwards thereby opening the Small Orifice (7) and allowing accumulated air to be discharged into atmosphere. As air is discharged the liquid raises the Float (4) and re-seals the Small Orifice (7) and prevents the escape of liquid.

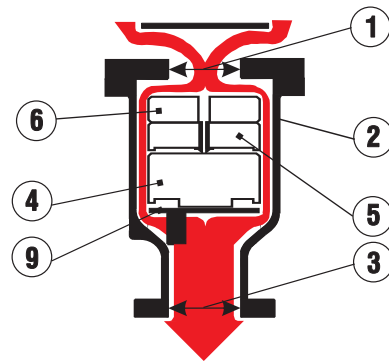

4

VACUUM RELIEF (AIR INTAKE) OF A DRAINING PIPELINE

Simultaneous drainage of liquid from Valve Chamber (2) causes Floats (4), (5) and (6) to gravitate downwards into the Baffle Plate (9), thereby allowing atmospheric air through the valve to rapidly displace draining liquid in the pipeline and prevent potentially damaging internal negative pressure.

AVAILABLE DISCHARGE CONNECTIONS DN25 (1") to DN300 (12")

Standard Screen Discharge
25 mm (1") to 300mm (12")

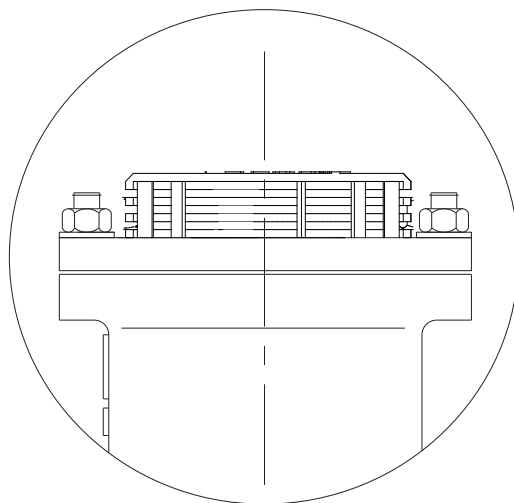

Alternative Arrangements can be provided on request

Screwed BSP
Discharge
25mm (1") to 100mm (4")

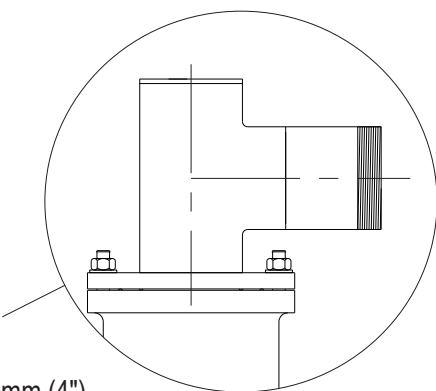

Swivel Discharge
25mm (1") to 300mm (12")

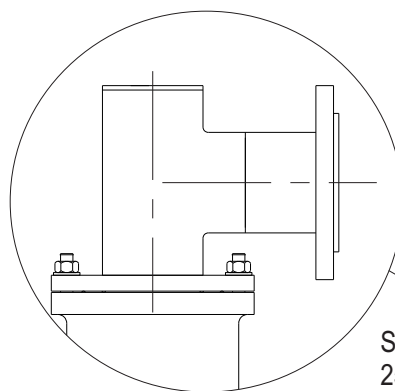

Screwed BSP
Discharge
25mm (1") to 100mm (4")

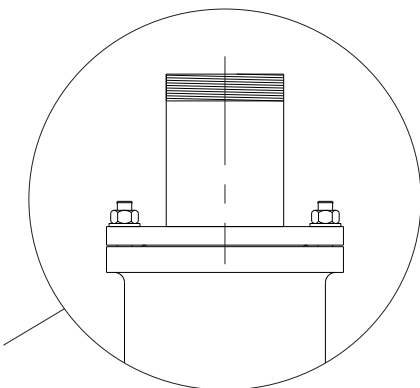

Swivel Discharge
25mm (1") to 300mm (12")

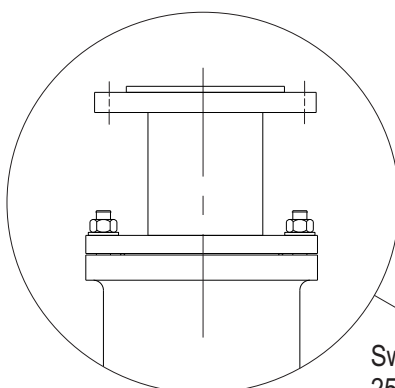

*NOTE
Discharge Connections Are Equal to Valve Pressure Rating

COMPONENT DESCRIPTION & MATERIAL SPECIFICATION DN25 & DN50 - SCREWED

Type:
Series RBXc - Double Orifice (Small & Large Orifice)
with Anti Shock Orifice Mechanism

End Connection:
Screwed BSP Female BS21 (ISO R7)
Screwed NPT Female ASME B1.20.1

Nominal Sizes:
DN 25 (1")
DN 50 (2")

Model No's:
RBXc 1611 & 1621 _____
RBXc 2511 & 2521 _____

Pressure Ratings:
PN 16 (232 PSI)
PN 25 (363 PSI)

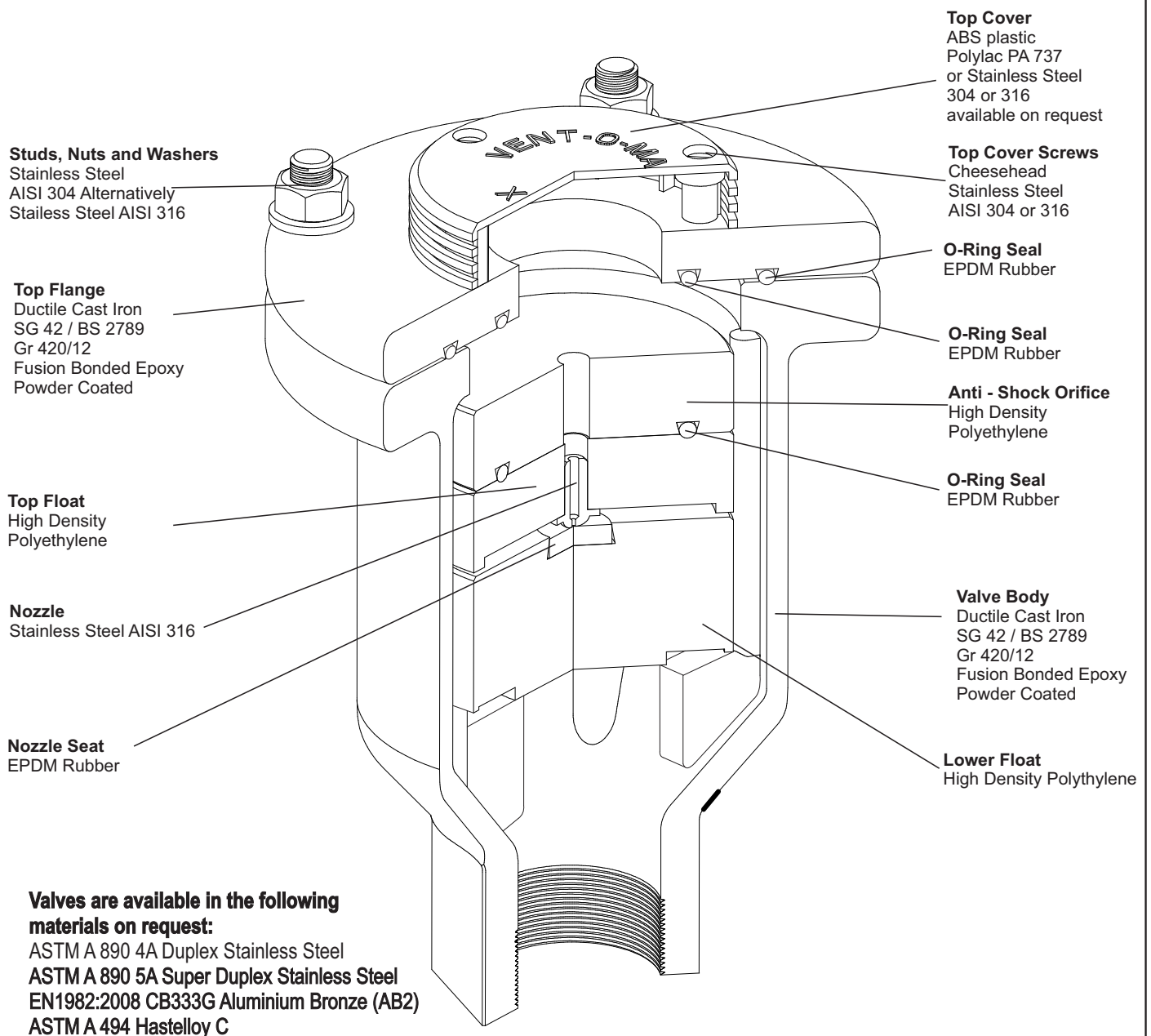

COMPONENT DESCRIPTION & MATERIAL SPECIFICATION DN25 (1") to DN300 (12") - FLANGED

Type:
Series RBXc - Double Orifice (Small & Large Orifice)
with Anti Shock Orifice Mechanism

End Connection:
Flanged

Nominal Sizes:

- DN 25 (1")
- DN 50 (2")
- DN 80 (3")
- DN 100 (4")
- DN 150 (6")
- DN 200 (8")
- DN 250 (10")
- DN 300 (12")

Model No's:

- RBXc 1601, 1631
- RBXc 2501 & 2531

Pressure Ratings:

- PN16 (232 PSI)
- PN25 (363 PSI)

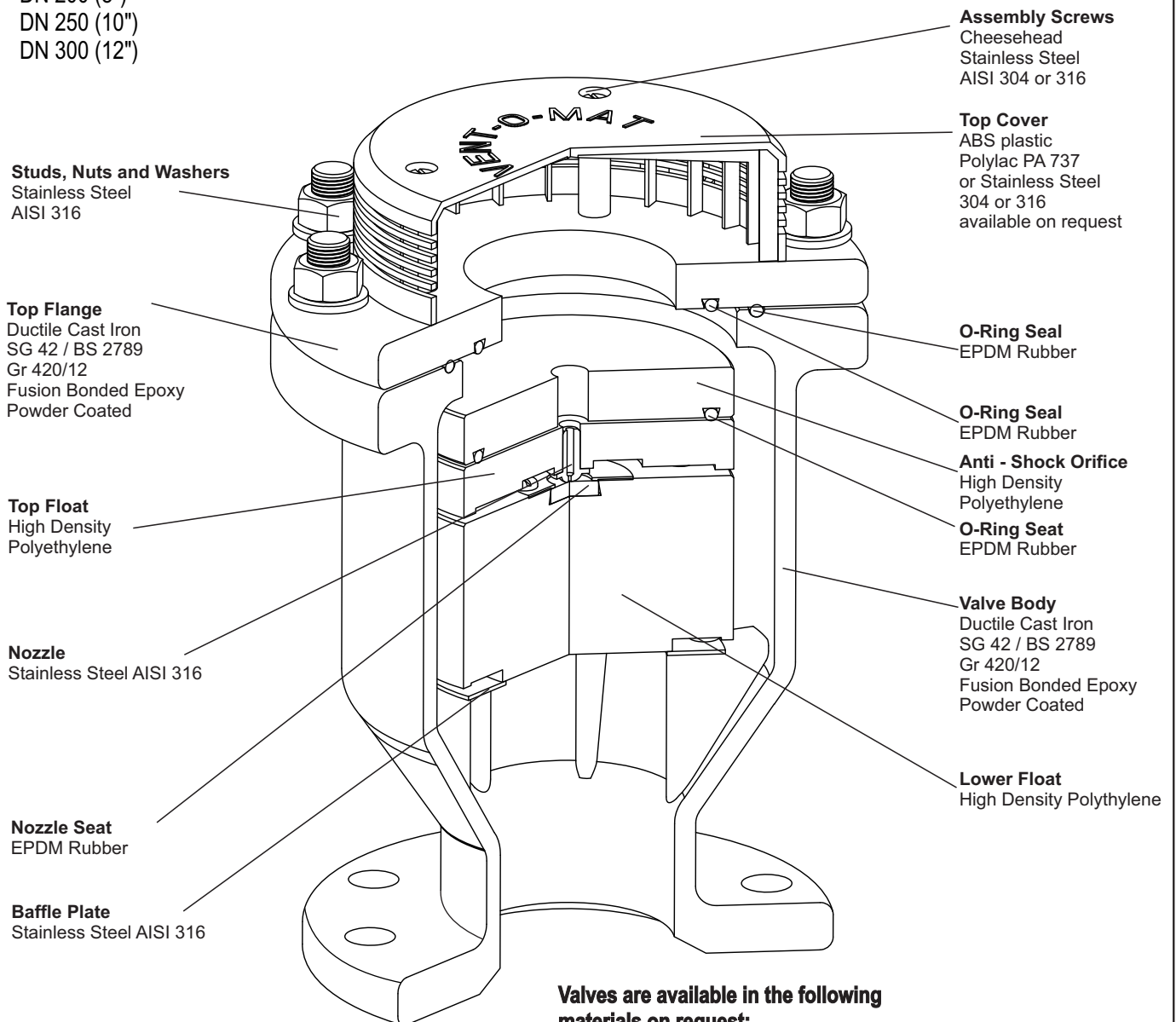

Valves are available in the following materials on request:

- ASTM A 890 4A Duplex Stainless Steel
- ASTM A 890 5A Super Duplex Stainless Steel
- EN1982:2008 CB333G Aluminium Bronze (AB2)
- ASTM A 494 Hastelloy C

GENERAL SPECIFICATIONS DN25 (1") & DN50 (2") - SCREWED

Type:

Double Orifice (Small & Large Orifice) with Anti Shock Orifice mechanism.

End Connection:

Screwed BSP/ NPT female

Nominal Sizes:

DN25 (1") & DN50 (2")

Model No's:

RBXc 1611 & 1621 _____ 16 bar (232 psi)

RBXc 2511 & 2521 _____ 25 bar (363 psi)

Pressure Ratings bar (psi):

Operating Pressure Range - bar (psi):

	Min	Max.
16 bar (232 psi) _____	0.5(7.2) _____	16 (232)
25 bar (363 psi) _____	0.5 (7.2) _____	25 (363)

Operating Temperature Range:

0 °C (35 °F) to 85 °C (185 °F)

Acceptable Media:

Potable or strained raw water.

Function:

- i) High volume air discharge - pipeline filling.
- ii) High volume air intake - pipeline draining
- iii) Pressurized air discharge - pipeline filled.
- iv) Surge dampening - high velocity air discharge, water column separation & liquid oscillation.

Materials of Construction: - see page 4

Installation: - see page 3

Standard Factory Tests:

- i) Hydrostatic - 1.5 x max. rated working pressure
- ii) Low head leak - 0.5 bar (7.2 psi)
- iii) Small orifice function at max. rated working pressure (minimum 1 valve in 10).

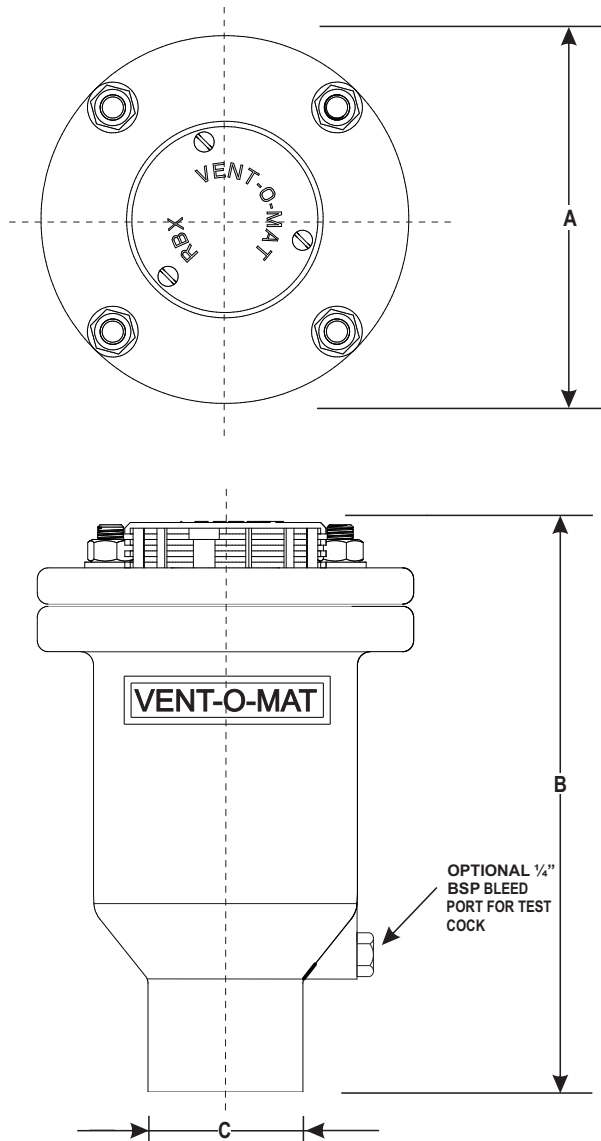

OVERALL DIMENSIONS & WEIGHTS

DN		MODEL No.	A		B		C	WEIGHT	
mm	in.		mm	in.	mm	in.		kg.	lbs.
025	1"	025RBXc 1611/21 & 2511/21	154	6.06	235	9.25	1" BSP/ 1" NPT	10	22
050	2"	050RBXc 1611/21 & 2511/21	174	6.85	249	9.79	2" BSP/ 2" NPT	13	29

GENERAL SPECIFICATIONS DN25 (1") TO DN300 (12") - FLANGED

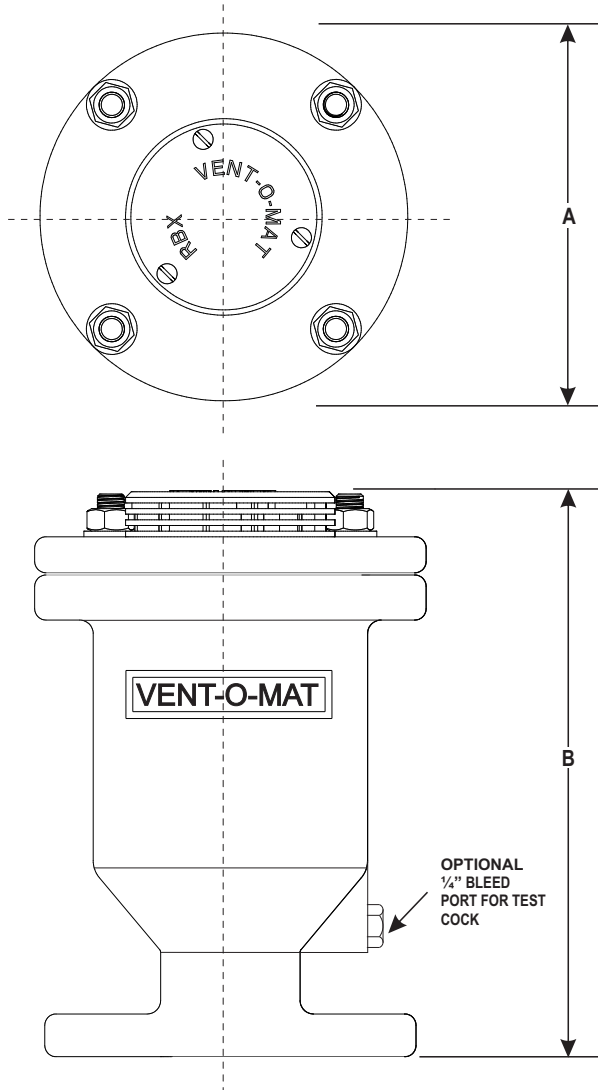

Type:

Double Orifice (Small & Large Orifice) with Anti Shock Orifice mechanism.

End Connection:

Flanged - ASME B16.5 Class 150
- BS EN 1092

Nominal Sizes:

DN25 (1") to DN300 (12")

Model No's:

RBXc 1601 & 1631 _____

RBXc 2501 & 2531 _____

Pressure Ratings bar (psi):

PN 16 (232 psi)

PN 25 (363 psi)

Operating Pressure Range - bar (PSI):

	Min	Max.
16 bar (232 psi) _____	0.5 (7.2) _____	16 (232)
25 bar (363 psi) _____	0.5 (7.2) _____	25 (363)

Operating Temperature Range:

0 C° (35 F°) to 85 C° (185 F°)

Acceptable Media:

Potable or strained raw water.

Function:

- i) High volume air discharge - pipeline filling.
- ii) High volume air intake - pipeline draining
- iii) Pressurized air discharge - pipeline filled.
- iv) Surge dampening - high velocity air discharge, water column separation & liquid oscillation.

Materials of Construction: - see page 6

Installation: - see page 3

Standard Factory Tests:

- i) Hydrostatic - 1.5 x max. rated working pressure
- ii) Low head leak - 0.5 bar
- iii) Small orifice function at max. rated working pressure (min. 1 valve in 10).

OVERALL DIMENSIONS & WEIGHTS

DN	MODEL No.		A		B		WEIGHT CAST	
	mm	in.	mm	in.	mm	in.	kg.	lbs.
025	1"	025RBXc1601	154	6.06	249	9.79	11	24
025	1"	025RBXc2501	154	6.06	252	9.92	13	29
050	2"	050RBXc1601	174	6.85	253	9.96	16	35
050	2"	050RBXc2501	174	6.85	265	10.09	18	40
080	3"	080RBXc1601	225	8.86	331	13.02	24	53
080	3"	080RBXc2501	225	8.86	336	13.23	29	64
100	4"	100RBXc1601	230	9.06	341	13.43	30	66
100	4"	100RBXc2501	230	9.06	349	13.74	33	73
150	6"	150RBXc1601	340	13.39	469	18.46	62	137
150	6"	150RBXc2501	340	13.39	480	18.90	68	150
200	8"	200RBXc1601	355	13.98	523	20.58	72	159
200	8"	200RBXc2501	355	13.98	535	21.06	80	176
250	10"	250RBXc1601	550	21.65	559	22.01	146	322
250	10"	250RBXc2501	550	21.65	565	22.24	156	344
300	12"	300RBXc1601	646	25.43	715	28.13	250	550
300	12"	300RBXc2501	646	25.43	723	28.46	267	588

SMALL ORIFICE DISCHARGE PERFORMANCE

Type:
 Series RBXc - Double Orifice (Small & Large Orifice)
 with 'Anti Shock Orifice' Mechanism

Model No's:
 RBXc 1601/1631
 RBXc 2501/2531

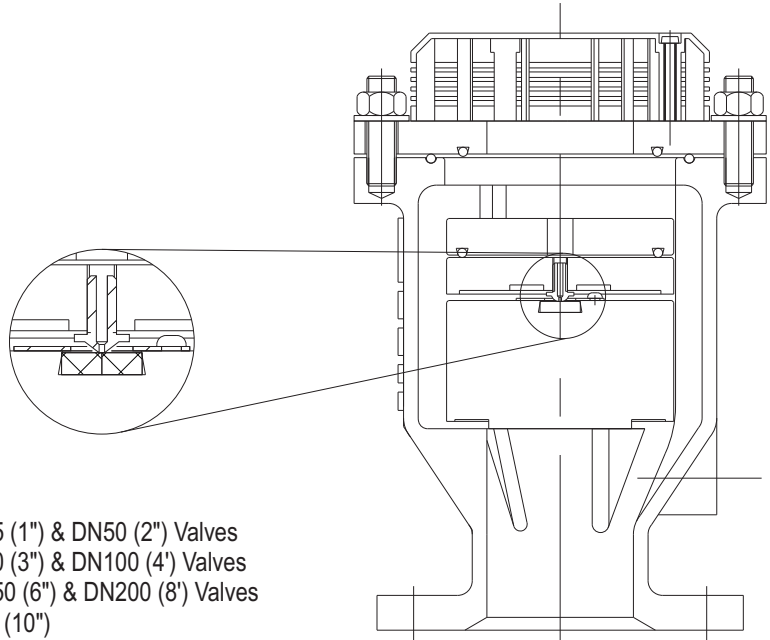

- █ \varnothing 1.2 mm (\varnothing 0.047") small orifice - DN25 (1") & DN50 (2") Valves
- █ \varnothing 1.5 mm (\varnothing 0.059") small orifice - DN80 (3") & DN100 (4") Valves
- █ \varnothing 2.4 mm (\varnothing 0.094") small orifice - DN150 (6") & DN200 (8") Valves
- █ \varnothing 3 mm (\varnothing 0.125") small orifice - DN250 (10")
- █ \varnothing 4 mm (\varnothing 0.157") small orifice - DN300 (12")

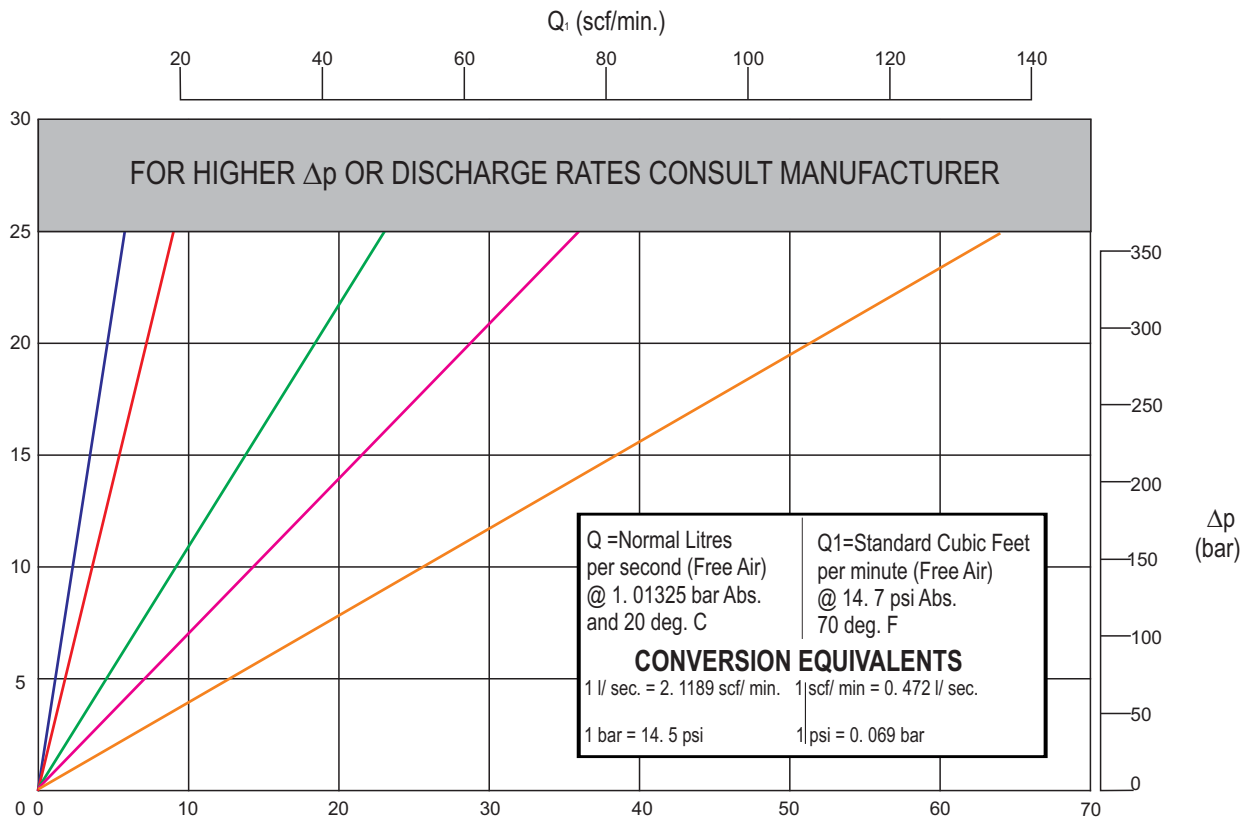

SELECTION & POSITIONING

VALVE SELECTION FROM GRAPH

All the relevant information has been condensed into one graph to enable valve selection to be simple and easy and at the same time to allow flexibility to the designer to move within certain parameters which eventually allows the most suited and economically viable valve to be selected.

IMPORTANT NOTE: The graph is based on vacuum breaking and limiting vacuum to 0.34 bar (5 psi) below atmospheric. It is not good practice to go below 0.69 bar (10 psi) absolute (0.303bar (4.4 psi) differential in pipeline at sea level). The graph allows for change in altitude and hence change in atmospheric pressure and is based on the assumption that more than one valve per section is used for vacuum protection and venting

ACTUAL SELECTION (GRAVITY OR PUMPED PIPELINES)

Selection is based on the premise that pipelines are generally filled at a slower rate than they are drained, scoured or at which separation occurs (a maximum fill/ drain ratio of 1:1).

1. Determine the maximum drainage rate in m/s either for scouring, pipe rupture or column separation for a particular pipeline section.
2. Move vertically on the graph from the m/s point and move horizontally from the pipe size finding the intersecting point.
3. This point should fall within the operating band of a particular valve size. Consideration must be given to the fact that the upper portion of the band approaches - 0.34 bar (5 psi) and the lower portion - 0.1 bar (1.45 psi) for each valve size, this allows the designer to see at a glance if the valve is too close to it's operating limits and to select the next valve size.

EXAMPLE OF VALVE SIZING (ASSUMING AN INDIVIDUAL SECTION)

A ϕ 400mm (16") pipeline draining at 377l/sec which equates to 3m/sec (10ft/s) what valve size should be selected?

From the 3m/sec (10ft/s) point, move vertically until the ϕ 400mm (16") pipe size horizontal line is intersected. This places the intersection point squarely in the centre of the operating band of a DN80 (3") Vent -O- Mat RBXc valve. But, if for example, the drainage rate is 503l/sec which equates to 4m/sec (13.2ft/s), the valve would be operating on it's limit and it may be prudent to change to a DN100 (4") Vent -O- Mat RBXc.

VALVE POSITIONING

1. ON APEX POINTS (relative to hydraulic gradient).
2. 5 METERS (16 FEET) BELOW APEX POINTS FORMED BY INTERSECTION OF PIPELINE AND HYDRAULIC GRADIENT - i.e. where pipeline siphoning over gradient a air release valve positioned on the apex would break the siphon. If positioning on apex is required a modified VENT -O- MAT Series RBXc can be supplied.
3. NEGATIVE BREAKS (increase in downward slope or decrease in upward slope).
4. LONG HORIZONTAL SECTIONS - every 600 meters (1/3 of a mile) maximum.
5. LONG ASCENDING SECTIONS - every 600 meters (1/3 of a mile) maximum.
6. LONG DESCENDING SECTIONS - every 600 meters (1/3 of a mile) maximum.
7. PUMP DISCHARGE (not shown in diagram) - just subsequent to non return valve.
8. BLANK ENDS (not shown in diagram) - where a pipeline is terminated by a blind flange or a valve.

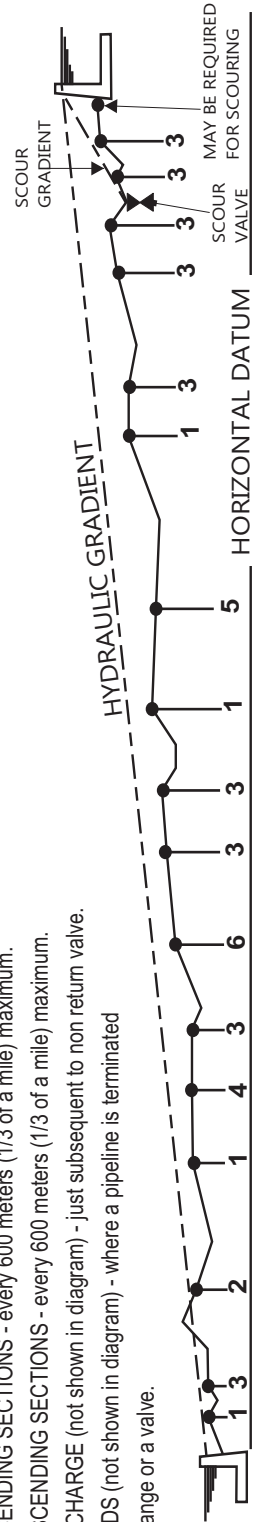

SELECTION & POSITIONING

PRE-NOTES

The functional limits of an air valve are governed by three physical laws namely: Joukowski's Equation Boyle's Law and Pascal's Law. Air valve operation however is also dependent on design and internal configuration, and can vary dramatically from manufacturer's product to manufacturer's product, within the parameters of what is physically possible. The basis of the Vent -O- Mat design is in the understanding of these laws, which have been used to design an air release and vacuum break valve that provides the optimum usable safe performance relative to all functions. The following summary is a general guideline of factors to consider when sizing air valves.

Sizing for Vacuum

Calculate necessary valve orifice sizes independently for each apex point.

Determine the smallest air release and vacuum break valve capable of admitting air into the pipeline equal to the potential water flow out of the pipeline whilst not exceeding a differential pressure that would put the pipeline and gasket joints at risk. We recommend 0.35 bar (5psi) Dp for steel pipe or lower if GRP, uPVC or HDPE pipe is being utilised. This exercise is simplified on pages 9 and 10 of this catalogue. **Be cautious of air valve designs with spherical floats as a low pressure zone is created above the float which causes it to partially close off the large orifice during air intake.**

Note that vacuum protection is dependent on valve size selection and orifice size relative to the nominal size of the valve. In sizing air valves be cautious of designs with restricted orifice diameters, i.e., orifice diameters that are smaller than the nominal size of the valve, as this could lead to insufficient vacuum protection and pipe collapse if not accommodated for. Vent -O- Mat large orifice diameters and flow path through the ale is equal to the nominal size of the valve e.g. a DN100 (4") ale has a 100mm (4") orifice. This ensures the least possible resistance to the intake of air and consequently the least possible negative pressure within a draining pipeline.

Sizing for Discharge

If a Vent -O- Mat air valve is sized correctly for air intake, discharge should not be a factor in sizing as all air will be discharged through the large orifice or "Anti-Shock" orifice (refer to RBXc operation on pages 1 and 2 of this catalogue). If this information is used for the sizing of air valves other than Vent-O-Mat recommend that ale be selected that is capable of discharging air equal to the filling rate, whilst not exceeding a differential of 0.05 bar (0.7) psi across the large orifice in order to prevent pressure surge and water hammer.

Pressurized Air Discharge

Effective discharge by an air release and vacuum break vale of pressurized air depends on the existence of a "Critical Relationship" between the area of the small orifice and the mass of the control float, i.e., the mass of the float must be greater than the force created by the working pressure acting on the orifice area. If the float is relatively too light or the orifice area relatively too great, the float will be held against the orifice even when not buoyed, and air discharge will not take place.

Surge Alleviation

It is imperative, due to the unpredictable nature of pipeline operation, that every air release and vacuum break valve should as standard, incorporate a surge and water hammer alleviation mechanism. This mechanism should only be activated in the instance of high velocity air discharge or pump trip (where the separated liquid columns rejoin at excessive velocities). The alleviation of surge and/or water hammer must be achieved by deceleration of the approaching liquid prior to valve closure (see operation of RBXc on pages 1 and 2 of this catalogue). Relief mechanisms that act subsequent to valve closure cannot react in the low millisecond time span required and are therefore unacceptable (refer to pages 11 and 12 of this catalogue).

Kindly contact the manufacturer for a free Air valve Sizing Disc and a copy of the Vent -O- Mat publication; "Air Valve Technology Reviewed", which gives a comprehensive guideline on air valve sizing as well as an in-depth look at air valve research and development over the past 35 years. Vent-O-Mat in addition provides assistance on air valve sizing and positioning.

SELECTION & POSITIONING

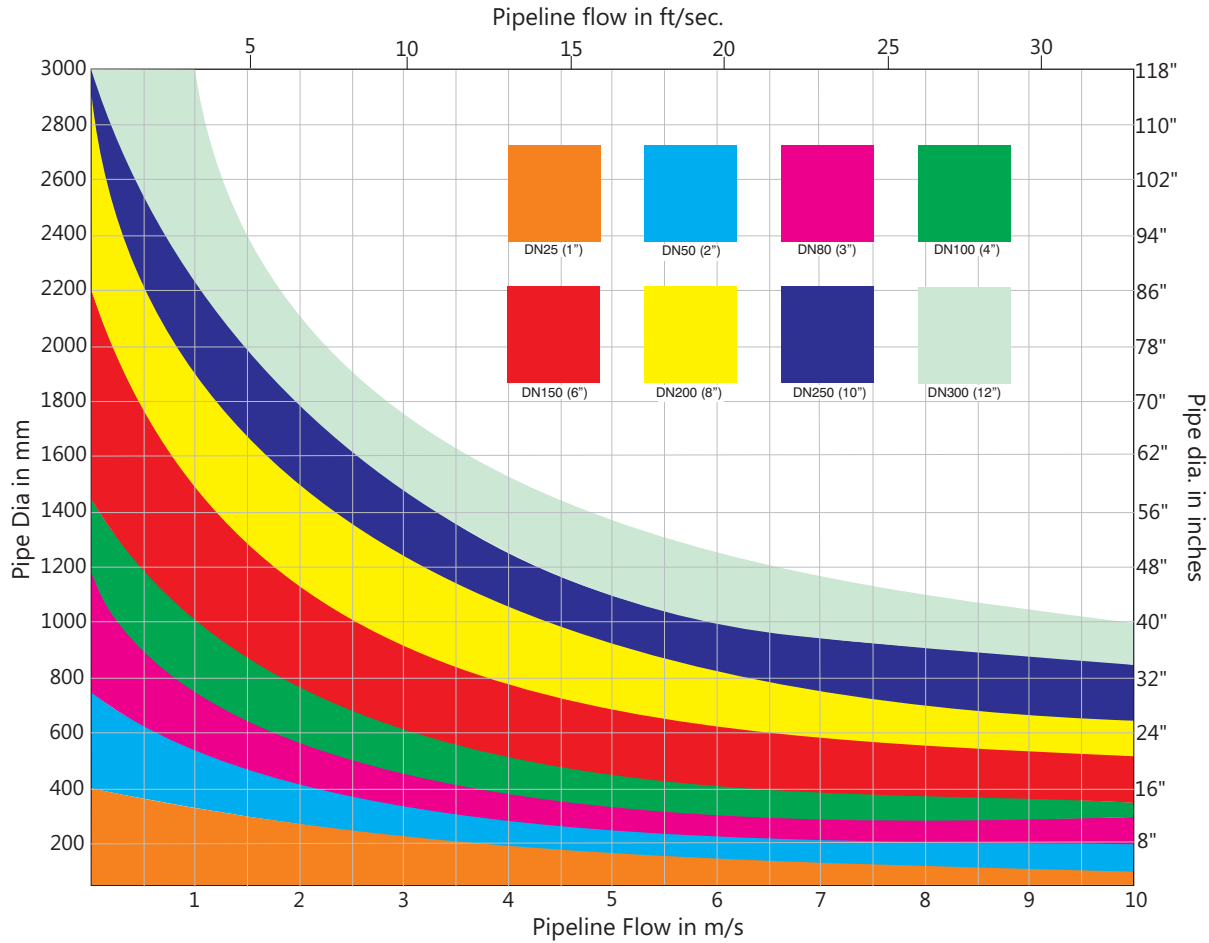

Pipe Dia mm	0.5	1	1.5	2	2.5	3	3.5	4	4.5	5	5.5	6	6.5	7	7.5	8	8.5	9	9.5	10
100	4	8	12	16	20	24	27	31	35	39	43	47	51	55	59	63	67	71	75	79
150	9	18	27	35	44	53	62	71	80	88	97	106	115	124	133	141	150	159	168	177
200	16	31	47	63	79	94	110	126	141	157	173	188	204	220	236	251	267	283	298	314
250	25	49	74	98	123	147	172	196	221	245	270	295	319	344	368	393	417	442	466	491
300	35	71	106	141	177	212	247	283	318	353	389	424	459	495	530	565	601	636	672	707
350	48	96	144	192	241	289	337	385	433	481	529	577	625	673	722	770	818	866	914	962
400	63	126	188	251	314	377	440	503	565	628	691	754	817	880	942	1005	1068	1131	1194	1257
450	80	159	239	318	398	477	557	636	716	795	875	954	1034	1113	1193	1272	1352	1431	1511	1590
500	98	196	295	393	491	589	687	785	884	982	1080	1178	1276	1374	1473	1571	1669	1767	1865	1963
550	119	238	356	475	594	713	832	950	1069	1188	1307	1425	1544	1663	1782	1901	2019	2138	2257	2376
600	141	283	424	565	707	848	990	1131	1272	1414	1555	1696	1838	1979	2121	2262	2403	2545	2686	2827
650	166	332	498	664	830	995	1161	1327	1493	1659	1825	1991	2157	2323	2489	2655	2821	2986	3152	3318
700	192	385	577	770	962	1155	1347	1539	1732	1924	2117	2309	2501	2694	2886	3079	3271	3464	3656	3848
750	221	442	663	884	1104	1325	1546	1767	1988	2209	2430	2651	2872	3093	3313	3534	3755	3976	4197	4418
800	251	503	754	1005	1257	1508	1759	2011	2262	2513	2765	3016	3267	3519	3770	4021	4273	4524	4775	5027
850	284	567	851	1135	1419	1702	1986	2270	2554	2837	3121	3405	3688	3972	4256	4540	4823	5107	5391	5675
900	318	636	954	1272	1590	1909	2227	2545	2863	3181	3499	3817	4135	4453	4771	5089	5407	5726	6044	6362
950	354	709	1063	1418	1772	2126	2481	2835	3190	3544	3899	4253	4607	4962	5316	5671	6025	6379	6734	7088
1000	393	785	1178	1571	1963	2356	2749	3142	3534	3927	4320	4712	5105	5498	5890	6283	6676	7069	7461	7854
1100	475	950	1425	1901	2376	2851	3326	3801	4276	4752	5227	5702	6177	6652	7127	7603	8078	8553	9028	9503
1200	565	1131	1696	2262	2827	3393	3958	4524	5089	5655	6220	6786	7351	7917	8482	9048	9613	10179	10744	11310
1300	664	1327	1991	2655	3318	3982	4646	5309	5973	6637	7300	7964	8628	9291	9955	10619	11282	11946	12610	13273
1400	770	1539	2309	3079	3848	4618	5388	6158	6927	7697	8467	9236	10006	10776	11545	12315	13085	13854	14624	15394
1500	884	1767	2651	3534	4418	5301	6185	7069	7952	8836	9719	10603	11486	12370	13254	14137	15021	15904	16788	17671
1600	1005	2011	3016	4021	5027	6032	7037	8042	9048	10053	11058	12064	13069	14074	15080	16085	17090	18096	19101	20106
1700	1135	2270	3405	4540	5675	6809	7944	9079	10214	11349	12484	13619	14754	15889	17024	18158	19293	20428	21563	22698
1800	1272	2545	3817	5089	6362	7634	8906	10179	11451	12723	13996	15268	16540	17813	19085	20358	21630	22902	24175	25447
1900	1418	2835	4253	5671	7088	8506	9924	11341	12759	14176	15594	17012	18429	19847	21265	22682	24100	25518	26935	28353
2000	1571	3142	4712	6283	7854	9425	10996	12566	14137	15708	17279	18850	20420	21991	23562	25133	26704	28274	29845	31416
2100	1732	3464	5195	6927	8659	10391	12123	13854	15586	17318	19050	20782	22513	24245	25977	27709	29441	31172	32904	34636
2200	1901	3801	5702	7603	9503	11404	13305	15205	17106	19007	20907	22808	24709	26609	28510	30411	32311	34212	36113	38013
2300	2077	4155	6232	8310	10387	12464	14542	16619	18696	20774	22851	24929	27006	29083	31161	33238	35315	37393	39470	41548
2400	2262	4524	6786	9048	11310	13572	15834	18096	20358	22619	24881	27143	29405	31667	33929	36191	38453	40715	42977	45239
2500	2454	4909	7363	9817	12272	14726	17181	19635	22089	24544	26998	29452	31907	34361	36816	39270	41724	44179	46633	49087
2600	2655	5309	7964	10619	13273	15928	18583	21237	23892	26546	29201	31856	34510	37165	39820	42474	45129	47784	50438	53093
2700	2863	5726	8588	11451	14314	17177	20039	22902	25765	28628	31491	34353	37216	40079	42942	45804	48667	51530	54393	57256
2800	3079	6158	9236	12315	15394	18473	21551	24630	27709	30788	33866	36945	40024	43103	46181	49260	52339	55418	58496	61575
2900	3303	6605	9908	13210	16513	19816	23118	26421	29723	33026	36329	39631	42934	46236	49539	52842	56144	59447	62749	66052
3000	3534	7069	10603	14137	17671	21206	24740	28274	31809	35343	38877	42412	45946	49480	53014	56549	60083	63617	67152	70686

Conversion Table l/sec. to m/sec. of Pipeline Velocity

Information subject to change without prior notice

SURGE & WATERHAMMER PROTECTION

Introduction

The Vent-O-Mat Series RBXc "Anti-Surge" air release and vacuum break valve, is an evolution of market feedback and the incorporation of the already proven Vent-O-Mat technology which itself resulted from years of extensive research. The valve unlike many others is not just an adaption of an air valve to handle sewage, but the result of over 30 years of dealing with water and seeing what works and adapting it to the needs of the end user.

Surge Protection - Initial Filling

The RBXc is always biased in the "Anti-Surge" mode meaning all air release is controlled through the "Anti-Surge" Orifice which is aerodynamically engineered to throttle air discharge when liquid approach velocity would otherwise become too great and induce an unacceptable pressure rise. The air throttling action increases resistance to the flow of the approaching liquid which consequently decelerates to a velocity which reduces the pressure rise when the valve closes (see operation of valve on pages 3). Vent-O-Mat series RBXc is an essential precaution for pipeline priming.

Surge Protection - Pump Trip Conditions

In instances where a pipeline experiences liquid column separation due to pump stoppage, high shock pressures can be generated when the separated liquid column rejoins.

The Vent-O-Mat series RBXc takes in air through the unobstructed large orifice when liquid column separation occurs, but controls the discharge of air through the "Anti-Surge" Orifice as the separated column commences to rejoin. The rejoining impact velocity is thereby considerably reduced to alleviate high surge pressures in the system (see operation of valve on page 3).

Other surge control measures may, dependant on pipeline profile, diameter and operating conditions, be needed to provide the primary surge alleviation function with the Vent-O-Mat air-valves forming an integral and valuable addition in a combined strategy for further reducing surge pressures. The benefit of the "Anti-Surge" Orifice can be readily demonstrated by suitable surge modelling software.

Surge Protection - Pipeline Operating

The operation of valves and similar flow control devices can cause high-pressure transients in an operating pipeline.

The unique, single chamber design of the Vent-O-Mat series RBXc valve enables a pocket of air to be trapped in the valve chamber. Automatic operation of the small orifice control float regulates the volume of air entrapped.

The volume maintained in the valve will provide a cushioning benefit to the pipeline for short duration transient pressure "spikes". This effect can be modelled by the design engineer using suitable surge software.

Computer Modelling

The effectiveness of Vent-O-Mat "Anti-Surge" technology has been substantiated by independent third party testing and by thousands of applications globally. Effective computer modelling, based on practical tests, has been ensured in the well-known and respected commercially available surge analysis software programmes such as AFT impulse, FLOWMASTER, WATHAM and SURGE 2000.

Technical and Financial Benefits

1. Improved alleviation of surge behaviour including reduction of:
 - Surge pressure magnitudes by slowing surge velocities
 - Duration of oscillation following a pump trip, as the air-valve continuously absorbs and dissipates the energies of the surge.
2. Potential for reduction in size and/or quantity of conventional surge protection devices such as surge vessels etc.
3. Automatic protection during initial filling when most surge protection devices are not operational.
4. Holistic protection as each sewage air valve installed has design features to automatically damp surges.
5. The valve is virtually maintenance free.

PURCHASE SPECIFICATION

VENT -O- MAT MODEL NO.

Page 7 - Series RBXc - DN25 or DN50 with BSP / NPT, Screwed Female Connection

Page 8 - Series RBXc - DN25 to DN300 Flanged Connection

CONSTRUCTION & DESIGN

The air release & vacuum break valve shall be of the compact single chamber design with solid cylindrical H.D.P.E. control floats housed in a tubular ductile cast iron body, epoxy powder coated to 300 microns, secured by means of stainless steel 304 or 316 fasteners.

The valve shall have an integral 'Anti - Shock' Orifice mechanism which shall operate automatically to limit transient pressure rise or shock induced by closure to 1.5 x valve rated working pressure.

The intake orifice area shall be equal to the nominal size of the valve i.e., a 150mm (6") valve shall have a 150mm (6") intake orifice.

Large orifice sealing shall be effected by the flat face of the control float seating against a E.P.D.M. rubber 'O' ring housed in a dovetail groove circumferentially surrounding the orifice.

Discharge of pressurized air shall be controlled by the seating & unseating of a small orifice nozzle on a E.D.P.M. rubber seal affixed into the control float. The nozzle shall have a flat seating land surrounding the orifice so that the damage to the rubber seal is prevented.

The valve construction shall be proportioned with regard to material strength characteristics, so that deformation, leaking or damage of any kind does not occur by submission to twice the designed working pressure.

Connection to the valve inlet shall be facilitated by a screwed BSP (ISO R7) or NPT female end (DN25 (1") & DN50 (2") only) or a flanged end conforming to PN10, 16 & 25 ratings of BS 4504 or SABS 1123 Standards, ANSI B16. 5 Class 150 & 300 & AS 4087.

Nuts, bolts, washers, or jointing gaskets shall be excluded.

The valve construction shall be proportioned with regard to material strength characteristics, so that deformation, leaking or damage of any kind does not occur by submission to 1.5 times the designed working pressure.

OPERATION

1. Prior to the ingress of liquid into the valve chamber, as when the pipeline is being filled, valves shall vent through the "Anti-Surge" orifice at all times.
2. Valves shall be tested and not exhibit leaks or weeping of liquid past the large orifice seal at operating pressures of 0,5 bar (7.2 psi) to 1.5 x valve rated working pressure.
3. When the pipeline is fully charged valves shall respond to the presence of air/gas by discharging it through the small orifice at the pressures within the specified design range, and shall remain leak tight in the absence of air.
4. Valves shall react immediately to pipeline drainage or liquid column separation by the full opening of the large orifice so as to allow unobstructed air intake at the lowest possible negative internal pipeline pressure.

ORDERING GUIDE

<p>VALVE SIZE:</p> <p>DN25 (1") - <input type="text" value="025"/></p> <p>DN50 (2") - <input type="text" value="050"/></p> <p>DN80 (3") - <input type="text" value="080"/></p> <p>DN100 (4") - <input type="text" value="100"/></p> <p>DN150 (6") - <input type="text" value="150"/></p> <p>DN200 (8") - <input type="text" value="200"/></p> <p>Dn250 (10") - <input type="text" value="250"/></p> <p>DN300 (12") - <input type="text" value="300"/></p> <p>VALVE SERIES No: _____</p> <p>ANTI SHOCK ORIFICE: _____</p> <p>CAST BODY: _____</p>	<p><input type="text" value="050"/> <input type="text" value="RB"/> <input type="text" value="X"/> <input type="text" value="c"/> <input type="text" value="25"/> <input type="text" value="0"/> <input type="text" value="1"/></p>	<p>VALVE TYPE: DOUBLE ACTING <input type="text" value="1"/></p> <p>VALVE END CONNECTION:</p> <p>SCREWED - BSP <input type="text" value="1"/></p> <p>SCREWED - NPT <input type="text" value="2"/></p> <p>FLANGED - BSEN 1092 <input type="text" value="0"/></p> <p>FLANGED - ANSI B16.5 <input type="text" value="3"/></p> <p>VALVE PRESSURE RATING:</p> <p>PN16 / ANSI#150 <input type="text" value="16"/></p> <p>PN25 / ANSI#300 <input type="text" value="25"/></p>
--	---	--

TEST SPECIFICATION

All air release valves supplied shall be subjected to the following testing procedures in the order laid down:

(A) A high pressure strength and leak test whereby the valve is filled with water and pressurized to 1.5 times the rated working pressure which shall be held for a period of 2 minutes. Any leaking, weeping or sweating shall be reason for rejection.

(B) A low head leak test whereby the valve is filled with water and pressurized to a maximum of 0.5 bar (7.3 psi) using a visible water column connected to the test rig. The valve shall be rejected if leak tightness is not maintained for 2 minutes

(C) Every tenth air release valve of the same size and pressure rating must be subjected to a small orifice function test - "DROP TEST" - whereby the valve is filled with water, pressurized to above rated working pressure and isolated from the test rig by closure of an isolating valve. A chamber in the test rig immediately prior to the isolating valve must be filled with compressed air at a pressure equal to that being maintained in the air release valve. The isolating valve is then opened so as to allow the air to rise in the air release valve without the pressure dropping lower than 2 - 3 bar (29 - 44 psi) above rated working pressure of the air release valve. The "DROP TEST" is then carried out by slowly bleeding off the pressure through a suitable cock until rated working pressure is reached and the float drops away from the orifice to allow discharge. Failure of the air release valve to function in the manner described will be reason for rejection.

On request the manufacturer shall provide batch certificates of test compliance which shall be cross referenced to serial numbers indelibly marked onto the identity label of each valve.

IMPORTANT NOTE: It is impossible to inject air into an incompressible liquid, air injection can only be achieved if the liquid can be displaced which implies that the pressure in the test rig must be reduced to atmospheric, and absolutely nothing is proven by discharge through the small orifice of the air release valve at atmospheric pressure. "DROP TESTING" in this manner is not acceptable.

GENERAL CONDITIONS OF TENDER AND SALE

1. DEFINITIONS

- 1.1 Seller:
Dynamic Fluid Control (Pty) Ltd
- 1.2 Purchaser:
The party who places an order on the Seller, which is accepted by the Seller in terms of Clause 2. (such acceptance hereinafter being referred to as "Acceptance of Order").
- 1.3 Goods
The materials, products and/or services ordered by the Purchaser and accepted by the Seller in terms of Clause 2, Contract.
These General Conditions of Tender and Sale, technical specifications of the Purchaser's order as have been specifically agreed in writing and the Acceptance of Order, together with only such other terms and conditions as may be specifically agreed in writing between the parties.

2. ACCEPTANCE OF ORDER

- 2.1 The Purchaser's order shall constitute an offer, and a contract shall only come into existence when the Seller accepts the Purchaser's order, by issuing an Acceptance of Order or by performing in response to the Order. Unless otherwise specifically agreed in writing in the contract any other terms and conditions including those forming part of the Purchaser's order, which deviate from the General Conditions, shall not form part of the Contract, and shall be of no force or effect.
- 2.2 In the event that the Purchaser and the Seller engage in negotiations over amendments or additions to or deletions from the General Conditions of Tender and Sale, these General Conditions shall govern the sale of the goods until such negotiations are finalised and these General Conditions amended (if at all) by agreement in writing.

3. SCOPE OF CONTRACT

- The Seller's obligations in terms of the Contract will be to produce the Goods in accordance with such designs, instructions, itemised details, plans, drawings, programmes and specifications (the specifications) as form part of the Contract, and in particular the Seller will not be responsible for the adequacy of or for any costs occasioned by the inadequacy of any such specifications or for any foundations or supporting structures of other work as may have been provided, prepared or specified by or on behalf of the Purchaser.

4. LIABILITY

- 4.1 Liability for Defects
The Seller undertakes that the Goods will conform to such specifications in respect of each other as have been specifically accepted by the Seller in writing and in the event of the Goods proving not to be in accordance with such specifications, the Seller shall, if requested to do so in writing within a reasonable time of discovery of such failure to conform to such specifications (hereinafter referred to as defects), but not in any event after 6 months have elapsed from the date of delivery of such defective Goods to the Purchaser, at its option, repair or replace the defective portions/components of the Goods, by supplying the repaired or replacement portion components of the Goods to the initial place of delivery, or at the further option of the Seller, to credit the Purchaser with the invoice value of the defective portion/components of the Goods in question. Notwithstanding anything to the contrary anywhere contained, the Seller shall have no liability in respect of any defects in the Goods, whether latent or patent, not notified to the Seller in writing before the end of the aforesaid 6 month period.
- 4.2 Liability for Delay
Subject to the provisions of Clause 8 and 10, the Seller undertakes to supply the Goods in accordance with such delivery dates as are specifically agreed in contract, and in the event that the Goods are not supplied in accordance with such dates, or within extensions or revisions of such dates, or if delays caused by the discovery of defects after delivery, the Seller's liability shall be limited to such penalty for late delivery as may have been specifically accepted by the Seller in writing in respect of each order accepted by the Seller. Such penalty shall only be payable in the event that, and to the extent that, the Purchaser is himself legally obliged to pay penalties in respect of each delay and in no event shall such penalty exceed 10% of the unescalated Contract Price of such portions of the Goods as cannot, because of the delay, be put to the use intended, and such penalty shall constitute the Seller's sole liability and the Purchaser's sole remedy for such delay. Notwithstanding anything to the contrary anywhere contained, the liability of the Seller howsoever arising out of the Contract or in Delict or by operation of statute shall not extend beyond the obligations specifically assumed in terms of this Clause 4, and the Seller.
- 4.3 gives no other warranties, expressed or implied in respect of (without limitation) workmanship, materials, fitness for purpose, merchantability or products liability not set out herein;
- 4.3.2 in respect of "brought out" or proprietary items not of its own manufacture, gives no greater warranty and accepts no greater liability than that given or accepted by and enforceable against the supplier/manufacturer thereof.
- 4.3.3 gives no warranties in respect of Goods used other than for the intended purpose, or for defects arising through fair wear and tear or neglect, shall in no event be liable for the Purchaser's loss of profits, loss of use, loss of production, loss of custom or goodwill, or for any special, indirect or consequential damages howsoever arising.

5. DELIVERY

- 5.1 Unless otherwise stipulated in the Contract, delivery shall be "ex the Seller's works" and the Contract Price is based on such "ex works" delivery and is exclusive of any sales tax payable in terms of any applicable statute, packaging, freight and insurance during transport.
- 5.2 The risk in and to the Goods will pass to the Purchaser on Delivery and claims for non delivery or for shortages or damage upon receipt of the Goods must be made in writing by the Purchaser within the earlier of 7 (seven) days of the relevant consignment note or receipt of the Goods as the case may be, failing which the Seller shall have no liability in respect of such claims.
Should the Purchaser fail or refuse to take delivery of the Goods when delivery is tendered by the Seller, the Purchaser shall be liable for such costs as may be incurred by the Seller as consequence thereof.

6. Contract Price

- Unless otherwise specifically agreed in writing in each particular instance:
- 6.1 the contract price to be paid by the Purchaser for the Goods shall be as set out in the tender and is based on the costs of materials, transport, labour, insurance rates, exchange rates and import duties ruling at the date of the tender and any variation in such costs or rates occurring between the date of the tender and the date of payment, shall be for the account of the Purchaser, and shall be determined in accordance with the formula included in the Contract, and if no formula is so included, in accordance with the prevailing relevant formulae, principles and indices published by SEIFSA.
- 6.2 If the Goods or any parts thereof are to be imported, the price will be based on the rates of exchange, freight, insurance premiums, lighterage, landing charges, port dues, custom duty and railage at the date of tender, or as specifically agreed. Should these rates vary between the date of the tender and the date upon which charges are incurred, the price shall be varied by the amount of the increase or decrease in such charges.

- 6.3 the Contract Price shall be paid in cash, free of exchange, deduction or set off within 30 (thirty) days of the date of Seller's statement, provided that in any event, notwithstanding delivery of the Goods to the Purchaser or to any third party, it is specifically agreed that it is the intention of the parties that the Goods shall not accede to any other property, whether moveable or immovable, and that it is as far as any other goods or equipment are concerned the Goods shall, for the purposes of accession be deemed to be the Principle items, and that ownership of the goods and any items accessory thereto shall at all times remain vested in the Seller, and shall not pass to the Purchaser until the full Contract Price has been paid. In the event of non-payment, the Purchaser hereby irrevocably authorises the Seller or its duly authorised agents to repossess the Goods wherever they may be found, and further, at its option, in detach or unmix by itself, its agents or servants, the Goods from anything to which they are attached or in which they are installed or annexed without being responsible for any damage that may be caused thereby and may, for such purpose, by itself, its servants or agents, enter upon any land or building, vehicle or vessel or other place upon which the Goods are reasonably thought to be situated.

- 6.4 Payments delayed after the due date for payment shall be subject to interest charges, compounded monthly with effect from the date of delivery, at prime bank overdraft rate.

- 6.5 Where payment by the Purchaser is effected by cheque, and where the post is used the risk of loss arising from the use of a cheque or the use of the post, shall rest with the Purchaser.

7. RENUNCIATION OF BENEFITS

- The Purchaser hereby renounces the benefits of any other rights; not expressly referred to in these General Conditions are not expressly agreed in writing and to which it may be entitled, or which it may acquire in terms of the Agricultural Credit Act, 28 of 1966 as amended, the Moratorium Act, 25 of 1963 or any other similar rights under any other statute.

8. VARIATIONS

- The Seller shall supply the Goods strictly in accordance with the Contract. Should the Purchaser require variations to the Goods, or to the quantities thereof, or should the Seller be hindered, delayed or prevented from supplying in terms of the Contract or be exposed to extra cost owing to extensions or to emissions from the order, deviations from the specifications, late, defective or non-receipt of information or re-issued materials or by any other act, default or omission by or on behalf of the Purchaser, the Seller shall be entitled to an appropriate variation to the rates or to the Contract Price or to the programme, or any other obligation of the Seller, provided that no such variation required by the Purchaser shall, without the written consent of the Seller, together with such other variations as may have been requested, involve a variation of more than 10% (ten per centum) to the Contract Price or to the quantities set out in the Contract.

9. RETURNS

- Returns, if accepted by the Seller at its sole discretion and upon such terms as it may prescribe, shall be credited Subject to a deduction of a minimum of 10% (ten per centum) as a handling charge, subject to the goods being within their specified shelf life and in a marketable condition and provided further that the Purchaser shall be liable for all costs of delivery to the Seller's designated premises.

10. FORCE MAJEURE

- 10.1 Neither party shall be liable to the other for inability to perform or delayed performances in terms of the Contract, should such inability delay arise from any cause beyond the reasonable control of such party, the existence or happening of which cause has been drawn to the attention of the other party within a reasonable time of the occurrence of such cause (hereinafter referred to as "a Force Majeure event").
- 10.2 For the purposes of this clause a Force Majeure event shall, without limitation to the generality of the foregoing, be defined to include, strikes, lock outs, labour disputes, accidents, plant and machinery breakdowns, fire, explosions, theft, war (whether declared or not) invasion, acts of foreign enemies, hostilities, riot, civil insurrection, flood, earthquake, lightning, act of local or national government, martial law, failure or delay or, the part of the Seller's supplier(s) of service, of "bought out" or raw materials, to meet delivery dates, or any failure or delay on the part of the Purchaser or the Purchaser's agents or other Contractors to provide the Seller with free issue materials, specifications, or defects or change s in such Specifications, or any other cause beyond the reasonable control of the party effected.

11. PATENTS COPYRIGHT AND CONFIDENTIALITY

- 11.1 The Purchaser shall indemnify and hold harmless the Seller against all claims and expenses of whatsoever nature and description arising from alleged or infringement of any Letters Patent, Trade Mark, Designs or Copyright occasioned by the Seller's performance of this Contract.
- 11.2 The Seller warrants however that any designs specified by it shall not infringe any of such Letters Patent, Trade Marks, Designs or Copyright.
- 11.3 The Purchaser shall keep confidential and shall not use for any purpose other than the Contract itself, all drawings and designs supplied by the Seller in terms of the Contract, and the Purchaser shall indemnify the Seller against any loss suffered by the Seller as a result of the breach of this clause. Such drawings and designs supplied by the Seller remains the exclusive property of the Seller and shall be promptly delivered and returned to the Company upon completion of the Contract.

12. BREACH

- Should either party be in breach of any material obligations imposed in terms of the Contract and fail to remedy such breach or take positive steps towards remedying such breach within 14 (fourteen) days of written notice of such breach from the other party, then the non defaulting party shall be entitled to cancel the Contract, without prejudice to such other rights that such non defaulting party may have in terms of this agreement or at law.

13. GOVERNING LAW AND DISPUTES

- 13.1 The Contract shall be construed and interpreted in accordance with, the laws of the Republic of South Africa.
- 13.2 Any disputes arising between the parties in respect of the Contract shall, at the option of the Seller, be justiciable before the Magistrates Court of South Africa having jurisdiction over the Purchaser, notwithstanding the fact that the dispute might otherwise have fallen outside the jurisdiction of such Magistrates Court and the Purchaser to such jurisdiction.

14. FUTURE CONTRACTS

- These General Conditions of Tender and Sale (as they may be amended from time to time) by the Seller shall also apply to any future, oral or written contract for the supply of goods and/or services by the Seller to the Purchaser, save to the extent that such conditions are in any future contracts specifically varied or excluded or are inconsistent with what is expressly agreed in any such future contract.

15. LANGUAGE

- These General Conditions of Tender and Sale are available in the other official language, upon request.

DFC DYNAMIC
FLUID CONTROL

Aveng DFC
P O Box 5064
Benoni South
1502
South Africa

Tel:- 27 11 748 0200
Fax:- 27 11 421 2749

dfc@dfc.co.za
www.ventomat.com



Revision Date Sept 2015 Catalogue RBXc0002