

Complements and Accessories

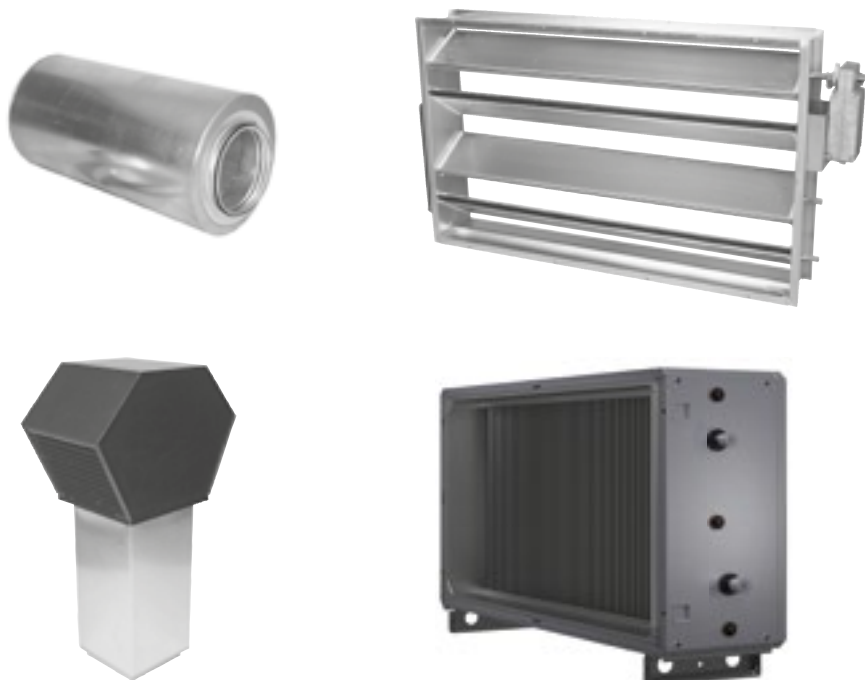

Contents

Chillers/heat pumps	260
GOLD RX/HC, Reversible heat pump	260
COOL DX/COOL DX Top, Cooling unit.....	275
Chiller, Echos+	282
Blue Box, Chiller/Heat pump.....	284
Air handling unit section	285
TCBR Air recirculation section.....	285
Solutions for fire bypass.....	286
Smoke extraction adapter.....	288
Duct crossover section	289
Multisection	290
Duct Accessories	292
Uninsulated	292
In insulated casing	313
Roof hoods and exterior wall hoods	352
Component box	353
Outdoor installation	354
Mechanical Equipment	355
Electrical and Control Equipment	359

Complements and Accessories

GOLD RX/HC

General

RX/HC is a complete reversible heat pump, fully integrated in the GOLD air handling unit.

Mechanical Design

RX/HC replaces the GOLD air handling unit's ordinary heat exchanger section.

RX/HC is available in all variants to match the equivalent GOLD air handling unit's different fan placements and right respective left-hand designs.

RX/HC consists of one section with sorption rotor and one section on each side of this that contains heating/cooling engineering components.

All components from a cooling and electrical standpoint are pre-wired.

The RX/HC section can be delivered in a variant with split refrigerant circuit. The RX/HC section can be divided into three units for transport into the work site. Assembly of the RX/HC section may only be performed by certified refrigeration technicians.

The casing is composed of cover panels and inspection doors. The outer skin is made of galvanized sheet steel, pre-painted in Swegon's grey metallic colour (closest comparable: RAL, 9007). The inner skin is made of aluminium-zinc plated sheet steel. Environmental Class C4. Panel thickness of 52 mm with intervening insulation consisting of mineral wool.

The evaporator and condenser consist of copper tubes and profiled aluminium fins.

RX/HC is test run prior to delivery.

RX/HC are designed and tested for ambient temperatures from -40°C to $+40^{\circ}\text{C}$. The heat pump function withstands temperatures from -25°C to $+35^{\circ}\text{C}$.

Control and Regulation

Heating/cooling engineering components have a separate integrated electrical cabinet which are operated via the GOLD air handling unit's hand-held micro terminal.

The refrigerant circuit contains a variable speed controlled compressor (all sizes) that regulates the output. Size 040-080 also comprises an on/off compressor for increased capacity.

Completely direct-acting system

The RX/HC has a completely direct-acting system. It has an evaporation coil for direct-evaporating refrigerant on the cold side and a condenser coil on the hot side.



RX/HC, size 012



Refrigerant

The refrigerant circuit is charged with refrigerant on delivery. The volume of refrigerant for each size is tabulated in the Technical Data Table.

Type R410A refrigerant is used. At present, this refrigerant has no known influence on the ozone layer and no known future restrictions are anticipated.

Inspection of the installation, obligation to report and periodic leakage tracing must be carried out according to the F-Gas Regulation EU/517/2014 and associated local legislation, also refer to the separate Installation and Maintenance Instructions for GOLD RX/HC.

Installation tips

When positioning the cooling unit, bear in mind that it must be possible to open the inspection doors as well as connect drainage pipework and power supply and control wiring without difficulty.

To drain the air cooler

The coils in RX/HC are equipped with a condensate drain tray and a drainage connection (condensate forms in the evaporator). The condensate discharge pipework must be connected across a water trap (accessory) to the drain connections of the cooling unit and must run with continuous slope to a drain gully. The air handling unit must be raised at least 50 mm to provide space for the water trap, ideally this is done with the support feet (accessory).

Complements and Accessories

GOLD RX/HC

Defrost

There are three options to defrost the exhaust coil (for the heat pump function), see below. For sizing, the product selection program AHU Design proposes suitable defrosting options for the specific operating case.

Reversing the refrigerant circuit.

Reversing the refrigerant circuit increases the temperature of the refrigerant in the exhaust coil, which means that the coil defrosts from the inside.

Reversing the refrigerant circuit + Electric air heater

Reversing the refrigerant circuit increases the temperature of the refrigerant in the exhaust coil, which means that the coil defrosts from the inside.

An electric air heater (accessory) is placed in front of the rotating heat exchanger, see diagram.

For defrosting, the electric air heater increases the temperature of the air before the heat exchanger. The heat exchanger transfers heat energy to the exhaust air. The temperature across the exhaust coil increases.

Reversing the refrigerant circuit + Air recirculation section RX/HC

Reversing the refrigerant circuit increases the temperature of the refrigerant in the exhaust coil, which means that the coil defrosts from the inside.

An air recirculation section RX/HC (accessory) is placed on the air handling unit's outdoor air/exhaust side, see diagram.

For defrosting, the air recirculation damper opens fully and the outdoor air/exhaust air damper closes fully. The warm extract air is recirculated. The temperature across the exhaust coil increases.

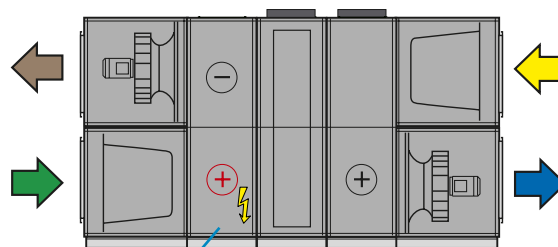

Electrical air heater placed in RX/HC (accessory)

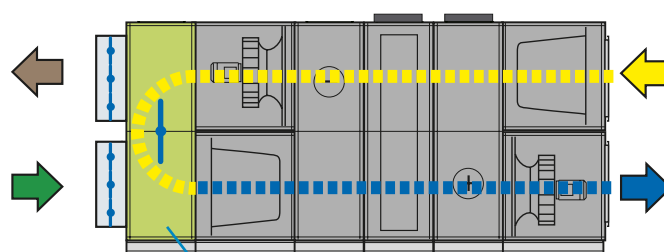

Air recirculation section RX/HC (accessory)

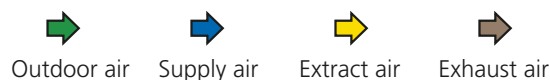

Air recirculation section RX/HC (accessory)

For GOLD	B	H	L	kg	End conn. panel, if required kg/pc.
011/012	1199	1295	565	92	13
014/020	1400	1551	565	110	19
025/030	1600	1811	565	125	23
035/040	1990	2159	565	142	34
050/060	2318	2288	565	168	34
070/080	2637	2640	565	229	40

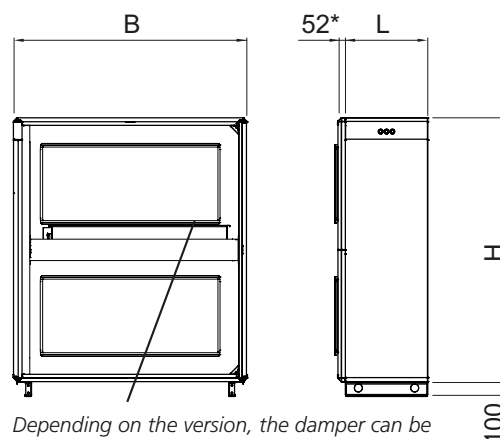

Depending on the version, the damper can be mounted in the upper or lower level.

* End connection panel selectable.

Complements and Accessories

GOLD RX/HC

Technical data

Size	Airflow at SFPv 1.8 (m ³ /s)	Min. airflow (m ³ /s)	Cooling cap. (kW) ¹⁾	Heating cap. (kW) ²⁾	Refrigerant (kg)	Power supply	EER ¹⁾	COP ²⁾
011	0.89	0.45	14.8 / 8.2	44.0 / 4.1	6	3 x 400V ±10%, +N +PE 16A	4.7	3.5
012	0.97	0.50	15.9 / 8.9	47.4 / 4.8	8	3 x 400V ±10%, +N +PE 25A	4.6	3.5
014	1.48	0.75	24.2 / 13.6	72.0 / 7.9	8	3 x 400V ±10%, +N +PE 25A	5.3	3.6
020	1.53	0.75	25.0 / 14.1	74.1 / 8.4	10	3 x 400V ±10%, +N +PE 25A	4.4	3.4
025	2.07	0.95	33.7 / 19.1	100.1 / 11.5	10	3 x 400V ±10%, +N +PE 25A	4.4	3.4
030	2.10	0.95	34.1 / 19.4	101.4 / 11.8	13	3 x 400V ±10%, +N +PE 32A	4.9	3.4
035	3.12	1.50	51.2 / 28.5	152.0 / 16.4	18	3 x 400V ±10%, +N +PE 50A	4.5	3.2
040	3.30	1.58	53.8 / 30.3	159.7 / 18.3	20	3 x 400V ±10%, +N +PE 50A	4.9	3.3
050	4.22	2.05	68.8 / 38.9	204.4 / 23.2	17.5	3 x 400V ±10%, +N +PE 63A	4.3	3.1
060	4.25	2.08	69.3 / 39.2	205.7 / 23.5	20	3 x 400V ±10%, +N +PE 63A	3.9	3.0
070	5.51	2.87	90.5 / 50.5	268.8 / 28.7	25	3 x 400V ±10%, +N +PE 63A	4.0	2.9
080	5.52	2.92	90.6 / 50.6	269.2 / 28.8	30	3 x 400V ±10%, +N +PE 80A	4.0	2.9

¹⁾ For an outdoor temperature of 26°C, 50% RH, extract air temperature of 22°C, supply air temperature 16°C.

Cooling capacity: rotating heat exchange / coil HC.

²⁾ For an outdoor temperature of -20°C, 95% RH, extract air temperature of 22°C, supply air temperature 20°C.

Heating capacity: rotating heat exchange / coil HC.

Sizing in AHU Design

For correct sizing we refer to our AHU Design air handling unit selection program.

Electrical and Control Equipment

General

The RX/HC is internally fully wired and trial run prior to delivery.

Equipment for heating/cooling engineering components are collected in an integrated electrical cabinet.

The safety isolating switch is located on the connection hood (size 011-020) or the air handling unit's inspection side (size 025-080).

Power supply

Wire the 400 V (5-conductor system) incoming power supply directly to the safety isolating switch.

Wire the electrical power supply connections according to the technical data tabulated above. Use delayed fuses! In applications where automatic circuit breakers are used, the circuit breakers must have C-characteristic.

Control and Regulation

A ready-to-use communication cable with quick connector for on/off switching, cooling capacity control as well as in-operation indication and alarms is used. The communication cable is supplied together with the unit.

Standards

The RX/HC is CE labelled in accordance with PED and the provisions of the EMC Directive for interference levels defined in SS-EN-50081-1 and SS-EN-61000-6-2 Standards (electromagnetic emissions in dwellings, office buildings, shops and similar environments as well as for immunity in industrial environments).

Applicable to installations in Sweden:

The unit meets the provisions of the ELSÄK-FS 1999:5 and SS-EN 60,204-1 and other applicable Swedish electrical safety standards and rules.

Hand-held terminal

Settings can be entered, readings can be viewed and possible alarms are displayed in the hand-held micro terminal of the GOLD air handling unit.

Complements and Accessories

GOLD RX/HC

Dimensions and weights

RX/HC 011

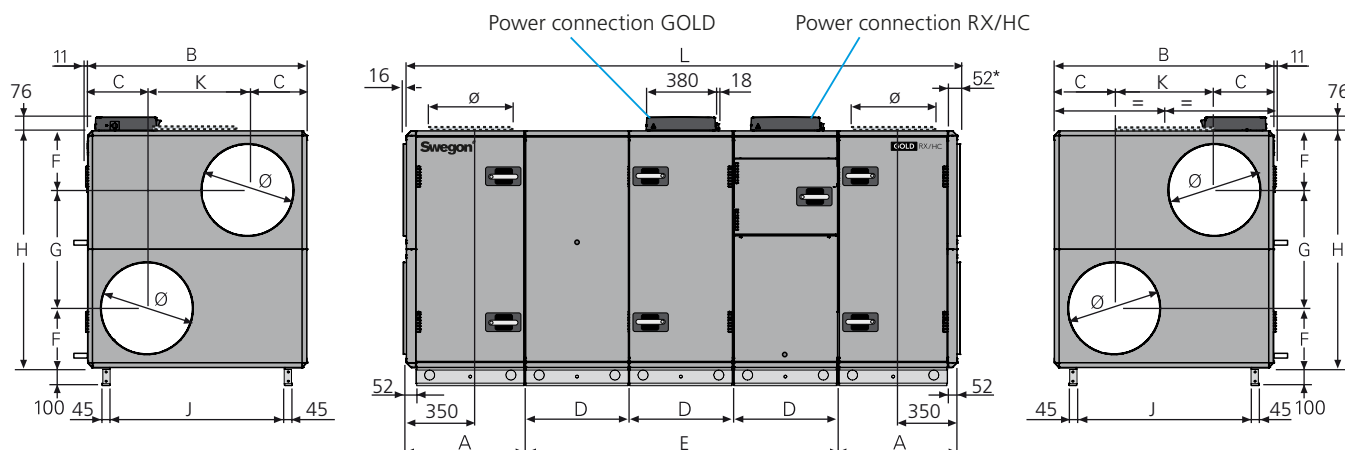

The diagram shows RX/HC integrated in a GOLD standard air handling unit set-up. The installation length for RX/HC corresponds to the E-measurement. Placement of the air handling unit sections, duct connections, connection hood, drain pipe, etc. may vary depending on the selected variant.

If a water trap (accessory) is fitted, the air handling unit must be raised at least 50 mm to provide space for the water trap. Support feet (accessories) can be used for this purpose.

* The air handling unit is supplied without end connection panel if a duct accessory housed in an insulated casing will be connected. The AHU can also be supplied with full face end connection panel (accessory).

Size	A	B	C	D	E	F	G	H	J	K	L	Ø	Weight, kg
011	647	1199	324	565	1695	324	647	1295	953	551	2989	500	737-845

Division into sections for transport

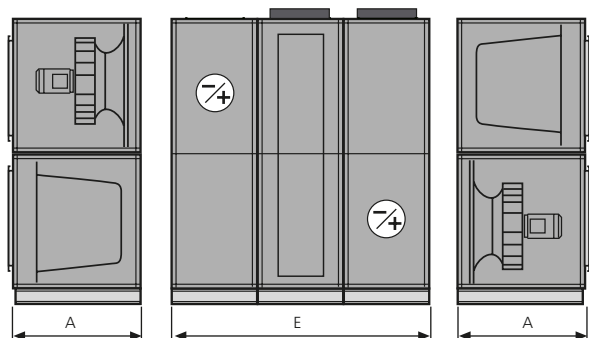

The unit can be divided into three air handling unit sections at the building site.

Dimensions: See A and E in the table above.

Weight: A = 135-175 kg,
E = 467-495 kg.

In addition to this, the middle section (RX/HC) can be delivered in a variant with split refrigerant circuit. The RX/HC section is then delivered assembled from the factory, but can be divided into three units on site, see D in the table above. Assembly of the RX/HC section may only be performed by certified refrigeration technicians.

Complements and Accessories

GOLD RX/HC

Dimensions and weights

RX/HC 012

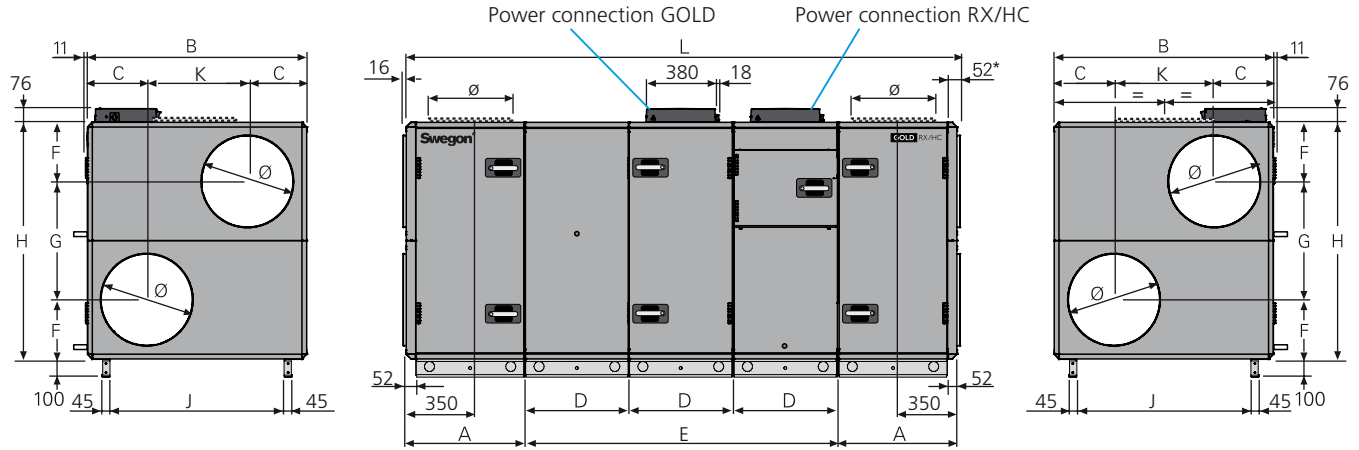

The diagram shows RX/HC integrated in a GOLD standard air handling unit set-up. The installation length for RX/HC corresponds to the E-measurement. Placement of the air handling unit sections, duct connections, connection hood, drain pipe, etc. may vary depending on the selected variant.

If a water trap (accessory) is fitted, the air handling unit must be raised at least 50 mm to provide space for the water trap. Support feet (accessories) can be used for this purpose.

* The air handling unit is supplied without end connection panel if a duct accessory housed in an insulated casing will be connected. The AHU can also be supplied with full face end connection panel (accessory).

Size	A	B	C	D	E	F	G	H	J	K	L	Ø	Weight, kg
012	647	1199	324	565	1695	324	647	1295	953	551	2989	500	765-879

Division into sections for transport

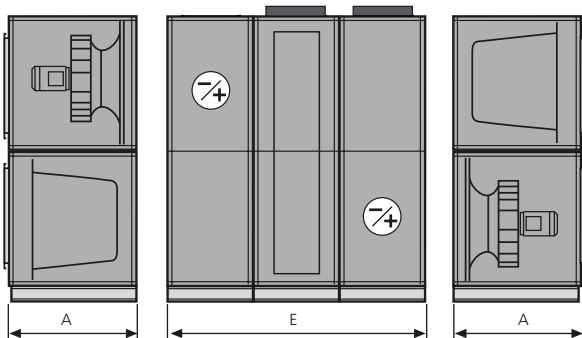

The unit can be divided into three air handling unit sections at the building site.

Dimensions: See A and E in the table above.

Weight: A = 146-189 kg,
E = 473-501 kg.

In addition to this, the middle section (RX/HC) can be delivered in a variant with split refrigerant circuit. The RX/HC section is then delivered assembled from the factory, but can be divided into three units on site, see D in the table above. Assembly of the RX/HC section may only be performed by certified refrigeration technicians.

Complements and Accessories

GOLD RX/HC

Dimensions and weights

RX/HC 014

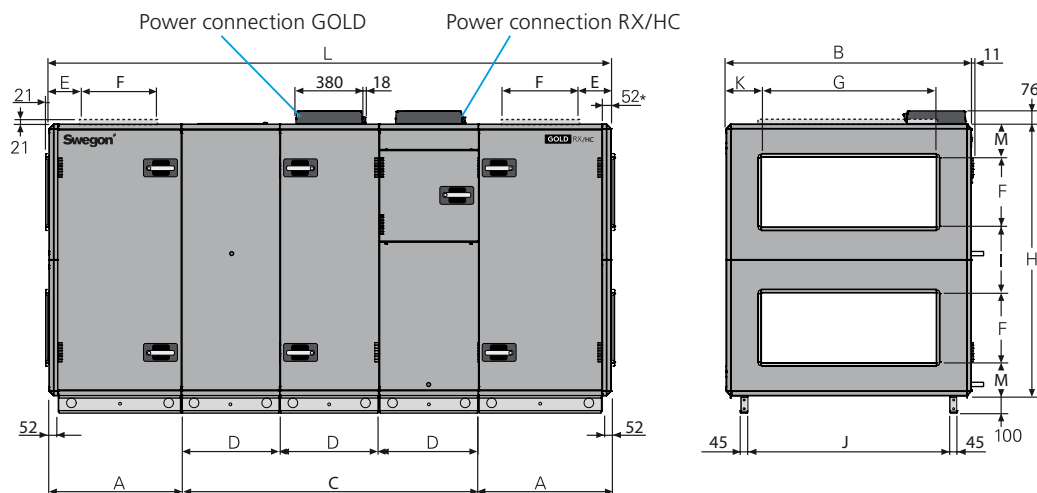

The diagram shows RX/HC integrated in a GOLD standard air handling unit set-up. The installation length for RX/HC corresponds to the C-measurement. Placement of the air handling unit sections, connection hood, drain pipe, etc. may vary depending on the selected variant.

If a water trap (accessory) is fitted, the air handling unit must be raised at least 50 mm to provide space for the water trap. Support feet (accessories) can be used for this purpose.

* The air handling unit is supplied without end connection panel if a duct accessory housed in an insulated casing will be connected. The AHU can also be supplied with full face end connection panel (accessory).

Size	A	B	C	D	E	F	G	H	I	J	K	L	M	Weight, kg
014	757,5	1400	1695	565	205	400	1000	1551	375	1154	200	3210	188	934-1074

Division into sections for transport

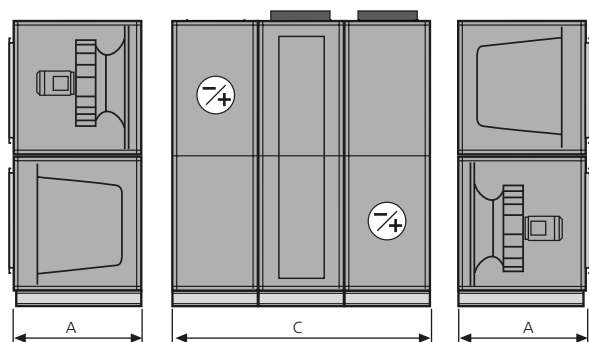

The unit can be divided into three sections at the building site.

Dimensions: See A and C in the table above.

Weight: A = 190-244 kg,

C = 554-586 kg.

In addition to this, the middle section (RX/HC) can be delivered in a variant with split refrigerant circuit. The RX/HC section is then delivered assembled from the factory, but can be divided into three units on site, see D in the table above. Assembly of the RX/HC section may only be performed by certified refrigeration technicians.

Complements and Accessories

GOLD RX/HC

Dimensions and weights

RX/HC 020

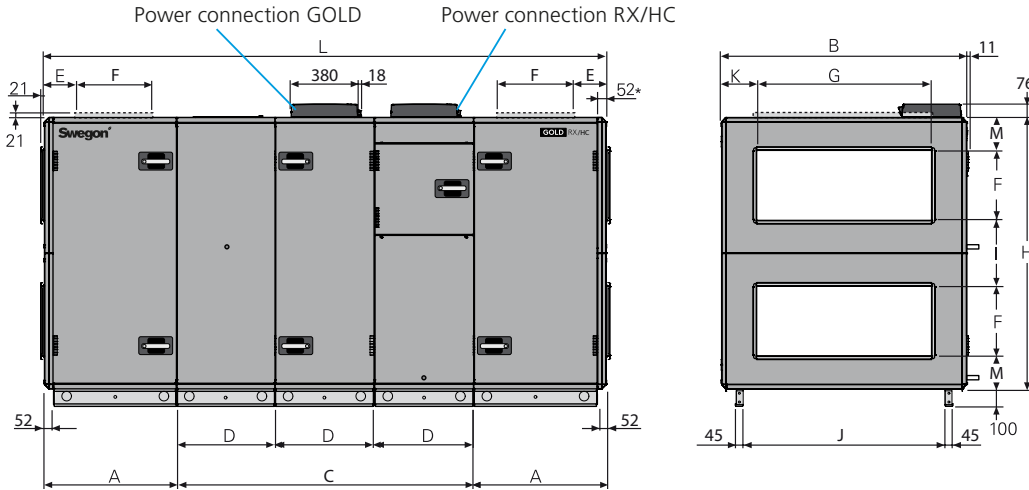

The diagram shows RX/HC integrated in a GOLD standard air handling unit set-up. The installation length for RX/HC corresponds to the C-measurement. Placement of the air handling unit sections, connection hood, drain pipe, etc. may vary depending on the selected variant.

If a water trap (accessory) is fitted, the air handling unit must be raised at least 50 mm to provide space for the water trap. Support feet (accessories) can be used for this purpose.

* The air handling unit is supplied without end connection panel if a duct accessory housed in an insulated casing will be connected. The AHU can also be supplied with full face end connection panel (accessory).

Size	A	B	C	D	E	F	G	H	I	J	K	L	M	Weight, kg
020	757,5	1400	1695	565	205	400	1000	1551	375	1154	200	3210	188	964-1124

Division into sections for transport

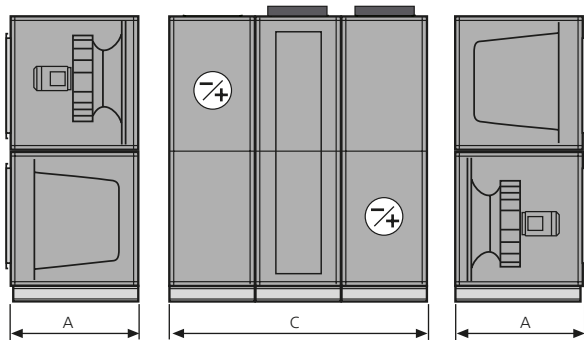

The unit can be divided into three sections at the building site.

Dimensions: See A and C in the table above.

Weight: A = 200-264 kg,
C = 564-596 kg.

In addition to this, the middle section (RX/HC) can be delivered in a variant with split refrigerant circuit. The RX/HC section is then delivered assembled from the factory, but can be divided into three units on site, see D in the table above. Assembly of the RX/HC section may only be performed by certified refrigeration technicians.

Complements and Accessories

GOLD RX/HC

Dimensions and weights

RX/HC 025

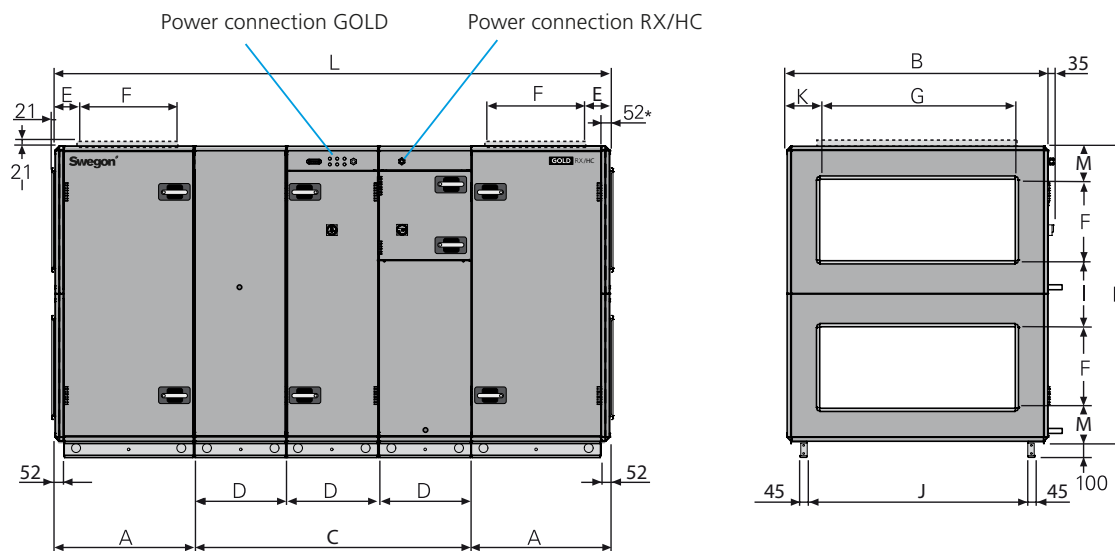

The diagram shows RX/HC integrated in a GOLD standard air handling unit set-up. The installation length for RX/HC corresponds to the C-measurement. Placement of the air handling unit sections, connection hood, drain pipe, etc. may vary depending on the selected variant.

If a water trap (accessory) is fitted, the air handling unit must be raised at least 50 mm to provide space for the water trap. Support feet (accessories) can be used for this purpose.

* The air handling unit is supplied without end connection panel if a duct accessory housed in an insulated casing will be connected. The AHU can also be supplied with full face end connection panel (accessory).

Size	A	B	C	D	E	F	G	H	I	J	K	L	M	Weight, kg
025	848	1600	1695	565	200	500	1200	1811	405	1354	200	3391	203	1238-1445

Division into sections for transport

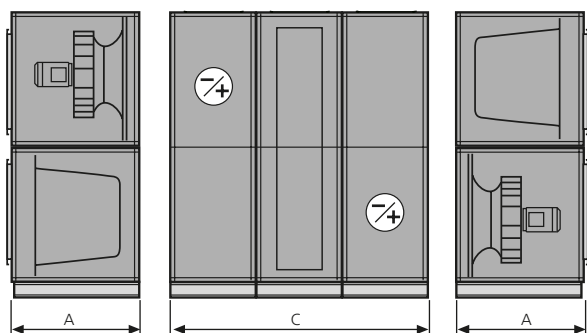

The unit can be divided into three sections at the building site.

Dimensions: See A and C in the table above.

Weight: A = 249-333 kg,
C = 740-779 kg.

In addition to this, the middle section (RX/HC) can be delivered in a variant with split refrigerant circuit. The RX/HC section is then delivered assembled from the factory, but can be divided into three units on site, see D in the table above. Assembly of the RX/HC section may only be performed by certified refrigeration technicians.

Complements and Accessories

GOLD RX/HC

Dimensions and weights

RX/HC 030

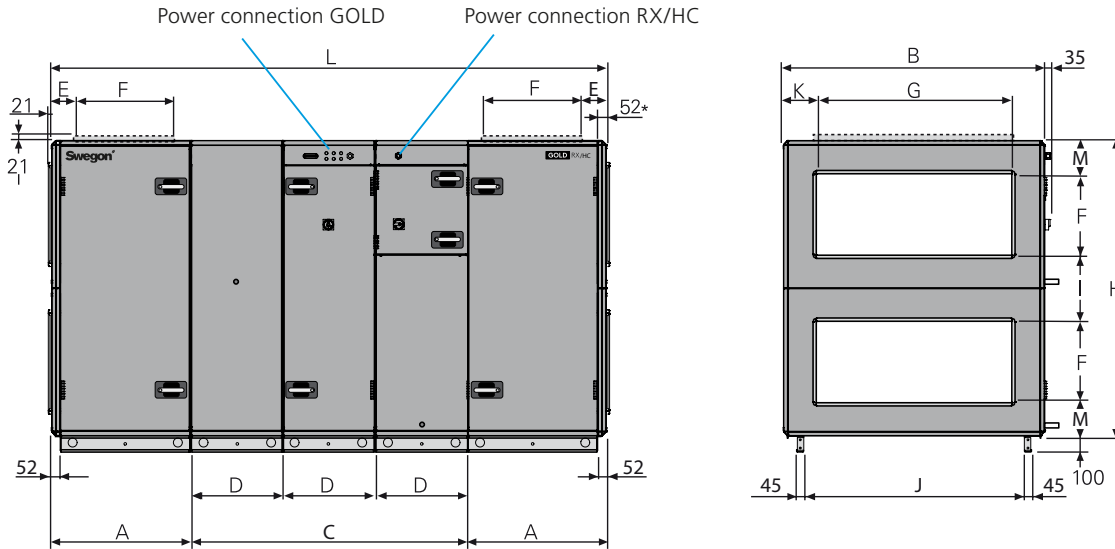

The diagram shows RX/HC integrated in a GOLD standard air handling unit set-up. The installation length for RX/HC corresponds to the C-measurement. Placement of the air handling unit sections, connection hood, drain pipe, etc. may vary depending on the selected variant.

If a water trap (accessory) is fitted, the air handling unit must be raised at least 50 mm to provide space for the water trap. Support feet (accessories) can be used for this purpose.

* The air handling unit is supplied without end connection panel if a duct accessory housed in an insulated casing will be connected. The AHU can also be supplied with full face end connection panel (accessory).

Size	A	B	C	D	E	F	G	H	I	J	K	L	M	Weight, kg
030	848	1600	1695	565	200	500	1200	1811	405	1354	200	3391	203	1300-1479

Division into sections for transport

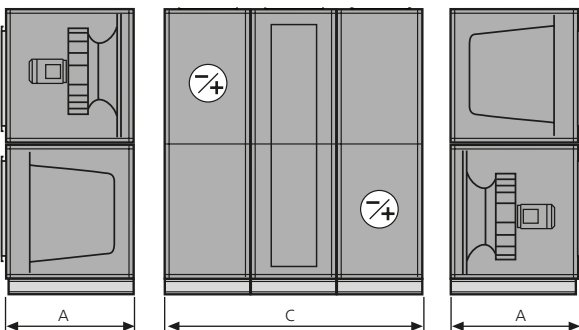

The unit can be divided into three sections at the building site.

Dimensions: See A and C in the table above.

Weight: A = 275-345 kg,
C = 750-789 kg.

In addition to this, the middle section (RX/HC) can be delivered in a variant with split refrigerant circuit. The RX/HC section is then delivered assembled from the factory, but can be divided into three units on site, see D in the table above. Assembly of the RX/HC section may only be performed by certified refrigeration technicians.

Complements and Accessories

GOLD RX/HC

Dimensions and weights

RX/HC 035

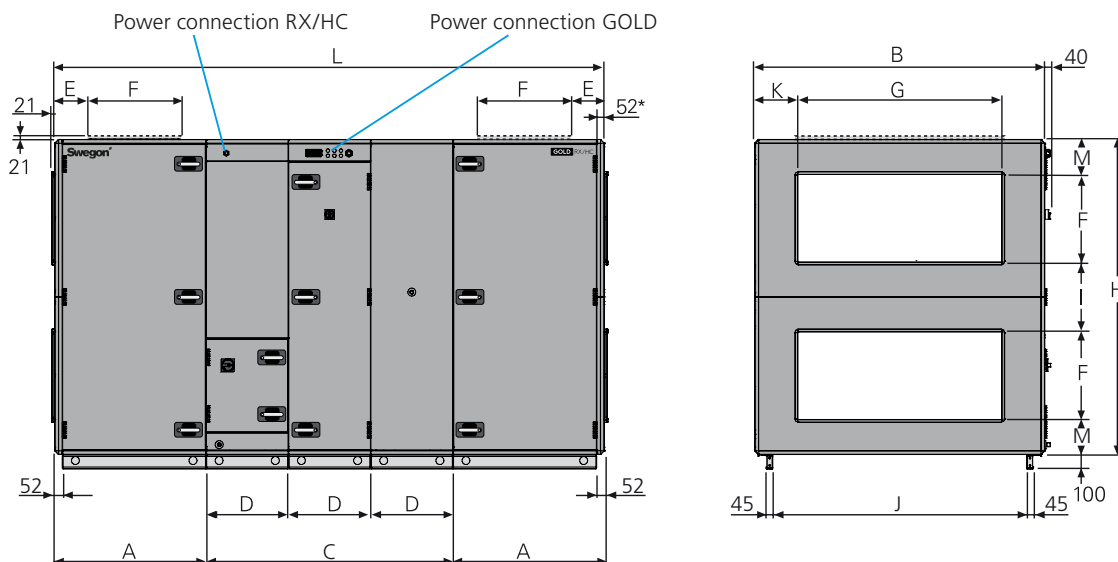

The diagram shows RX/HC integrated in a GOLD standard air handling unit set-up. The installation length for RX/HC corresponds to the C-measurement. Placement of the air handling unit sections, connection hood, drain pipe, etc. may vary depending on the selected variant.

If a water trap (accessory) is fitted, the air handling unit must be raised at least 50 mm to provide space for the water trap. Support feet (accessories) can be used for this purpose.

* The air handling unit is supplied without end connection panel if a duct accessory housed in an insulated casing will be connected. The AHU can also be supplied with full face end connection panel (accessory).

Size	A	B	C	D	E	F	G	H	I	J	K	L	M	Weight, kg
035	1038,5	1990	1695	565	245	600	1400	2159	479	1744	295	3772	240	1664-1922

Division into sections for transport

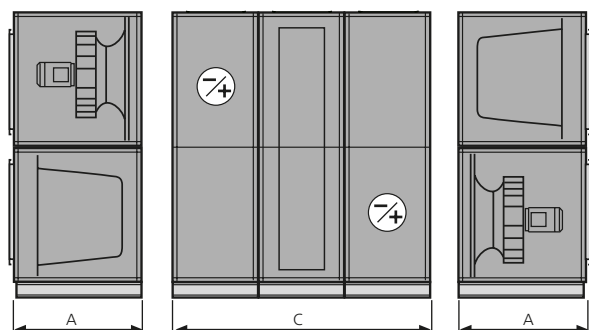

The unit can be divided into three sections at the building site.

Dimensions: See A and C in the table above.

Weight: A = 377-482 kg,
C = 910-958 kg.

In addition to this, the middle section (RX/HC) can be delivered in a variant with split refrigerant circuit. The RX/HC section is then delivered assembled from the factory, but can be divided into three units on site, see D in the table above. Assembly of the RX/HC section may only be performed by certified refrigeration technicians.

Complements and Accessories

GOLD RX/HC

Dimensions and weights

RX/HC 040

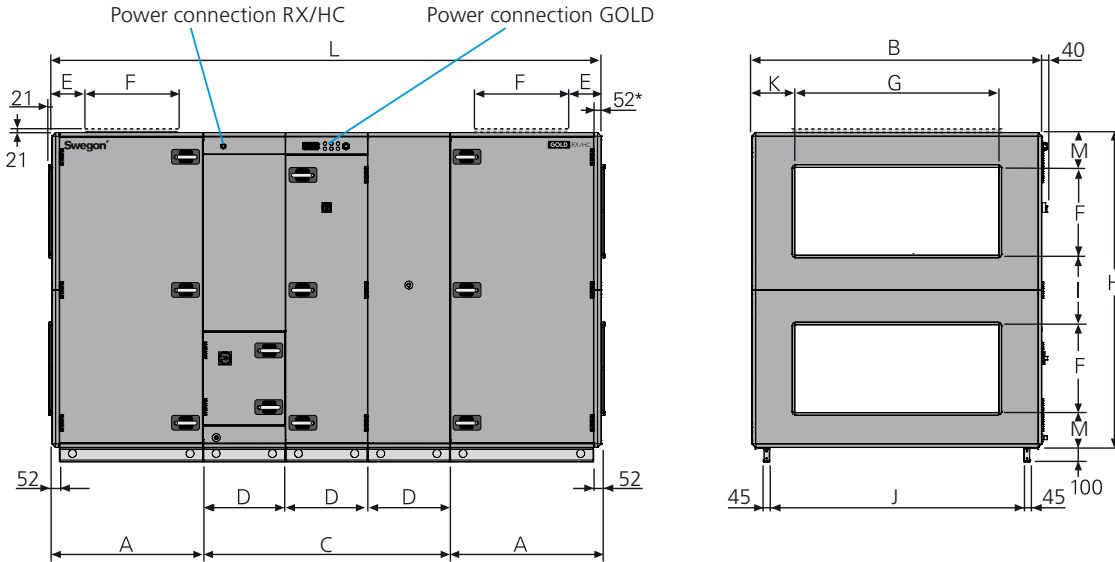

The diagram shows RX/HC integrated in a GOLD standard air handling unit set-up. The installation length for RX/HC corresponds to the C-measurement. Placement of the air handling unit sections, connection hood, drain pipe, etc. may vary depending on the selected variant.

If a water trap (accessory) is fitted, the air handling unit must be raised at least 50 mm to provide space for the water trap. Support feet (accessories) can be used for this purpose.

* The air handling unit is supplied without end connection panel if a duct accessory housed in an insulated casing will be connected. The AHU can also be supplied with full face end connection panel (accessory).

Size	A	B	C	D	E	F	G	H	I	J	K	L	M	Weight, kg
040	1038,5	1990	1695	565	245	600	1400	2159	479	1744	295	3772	240	1740-2016

Division into sections for transport

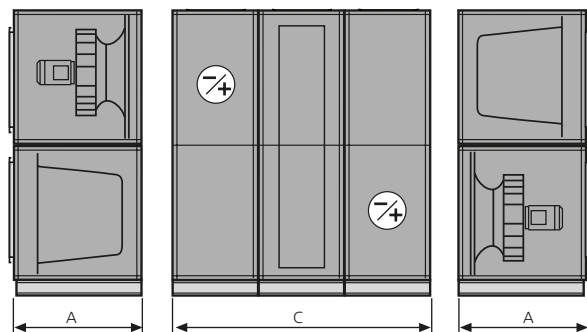

The unit can be divided into three sections at the building site.

Dimensions: See A and C in the table above.

Weight: A = 390-504 kg,
C = 960-1008 kg.

In addition to this, the middle section (RX/HC) can be delivered in a variant with split refrigerant circuit. The RX/HC section is then delivered assembled from the factory, but can be divided into three units on site, see D in the table above. Assembly of the RX/HC section may only be performed by certified refrigeration technicians.

Complements and Accessories

GOLD RX/HC

Dimensions and weights

RX/HC 050

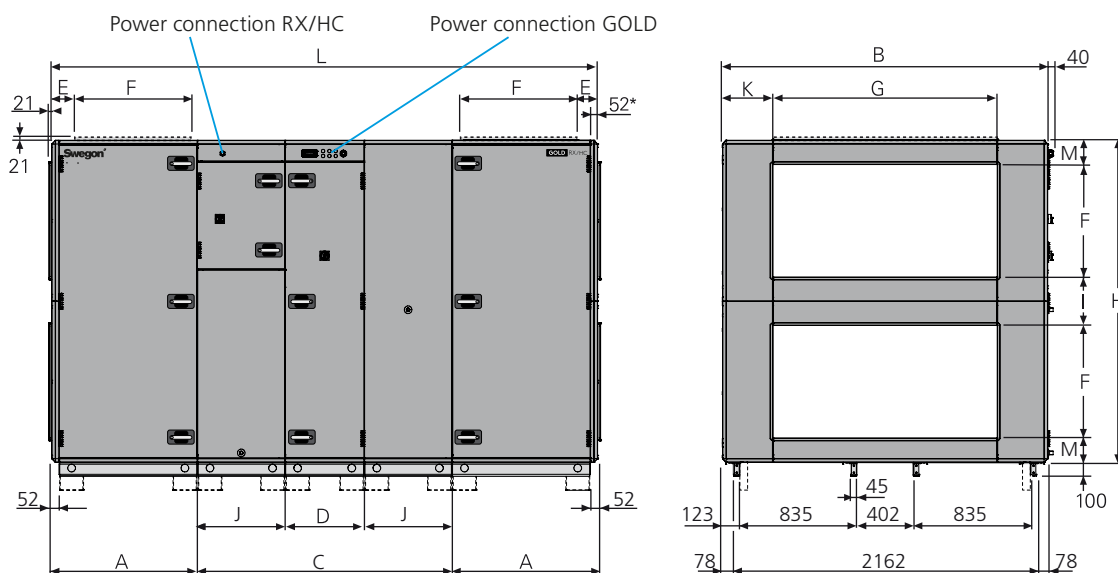

The diagram shows RX/HC integrated in a GOLD standard air handling unit set-up. The installation length for RX/HC corresponds to the C-measurement. Placement of the air handling unit sections, connection hood, drain pipe, etc. may vary depending on the selected variant.

Supplied on 100 mm high transport feet. Removed when the unit is at its final location. If a water trap (accessory) is fitted, the air handling unit must be raised at least 50 mm to provide space for the water trap. Adjustable support feet (accessories) can be appropriately fitted to the base beams for this purpose.

* The air handling unit is supplied without end connection panel if a duct accessory housed in an insulated casing will be connected. The AHU can also be supplied with full face end connection panel (accessory).

Size	A	B	C	D	E	F	G	H	I	J	K	L	M	Weight, kg
050	1038,5	2318	1815	565	145	800	1600	2288	344	625	359	3892	172	2138-2445

Division into sections for transport

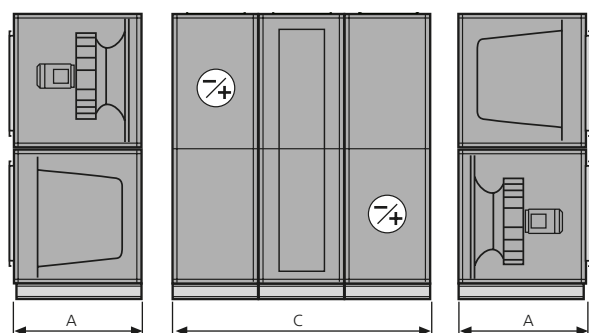

The unit can be divided into three sections at the building site.

Dimensions: See A and C in the table above.

Weight: A = 444-572 kg,
C = 1250-1301 kg.

In addition to this, the middle section (RX/HC) can be delivered in a variant with split refrigerant circuit. The RX/HC section is then delivered assembled from the factory, but can be divided into three units on site, see D and J in the table above. Assembly of the RX/HC section may only be performed by certified refrigeration technicians.

Complements and Accessories

GOLD RX/HC

Dimensions and weights

RX/HC 060

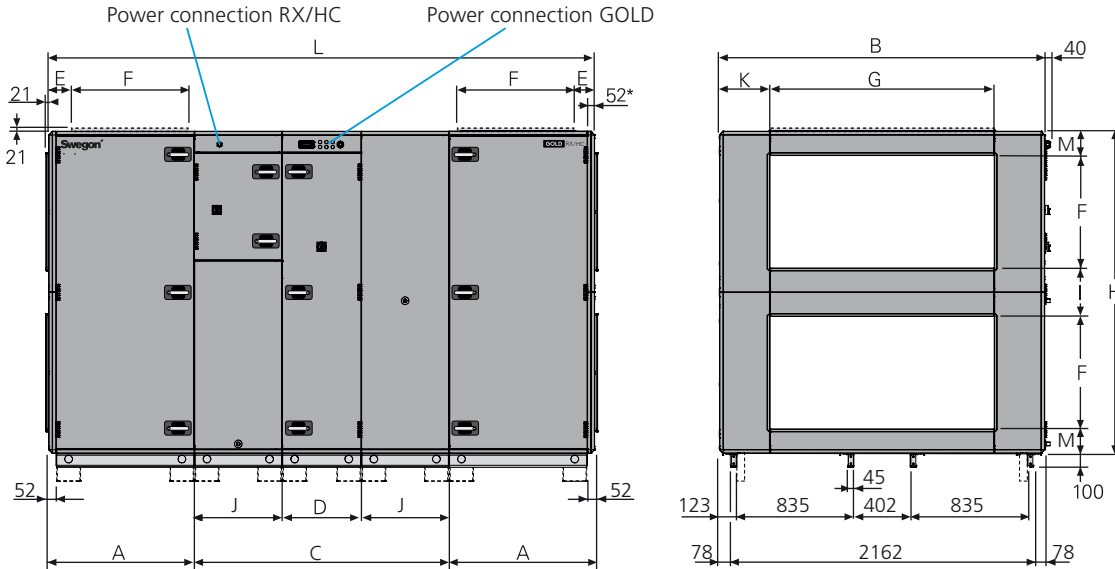

The diagram shows RX/HC integrated in a GOLD standard air handling unit set-up. The installation length for RX/HC corresponds to the C-measurement. Placement of the air handling unit sections, connection hood, drain pipe, etc. may vary depending on the selected variant.

Supplied on 100 mm high transport feet. Removed when the unit is at its final location. If a water trap (accessory) is fitted, the air handling unit must be raised at least 50 mm to provide space for the water trap. Adjustable support feet (accessories) can be appropriately fitted to the base beams for this purpose.

* The air handling unit is supplied without end connection panel if a duct accessory housed in an insulated casing will be connected. The AHU can also be supplied with full face end connection panel (accessory).

Size	A	B	C	D	E	F	G	H	I	J	K	L	M	Weight, kg
060	1038,5	2318	1815	565	145	800	1600	2288	344	625	359	3892	172	2322-2611

Division into sections for transport

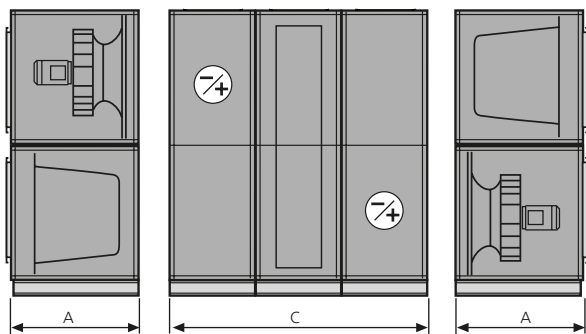

The unit can be divided into three sections at the building site.

Dimensions: See A and C in the table above.

Weight: A = 511-630 kg,
C = 1300-1351 kg.

In addition to this, the middle section (RX/HC) can be delivered in a variant with split refrigerant circuit. The RX/HC section is then delivered assembled from the factory, but can be divided into three units on site, see D and J in the table above. Assembly of the RX/HC section may only be performed by certified refrigeration technicians.

Complements and Accessories

GOLD RX/HC

Dimensions and weights

RX/HC 070

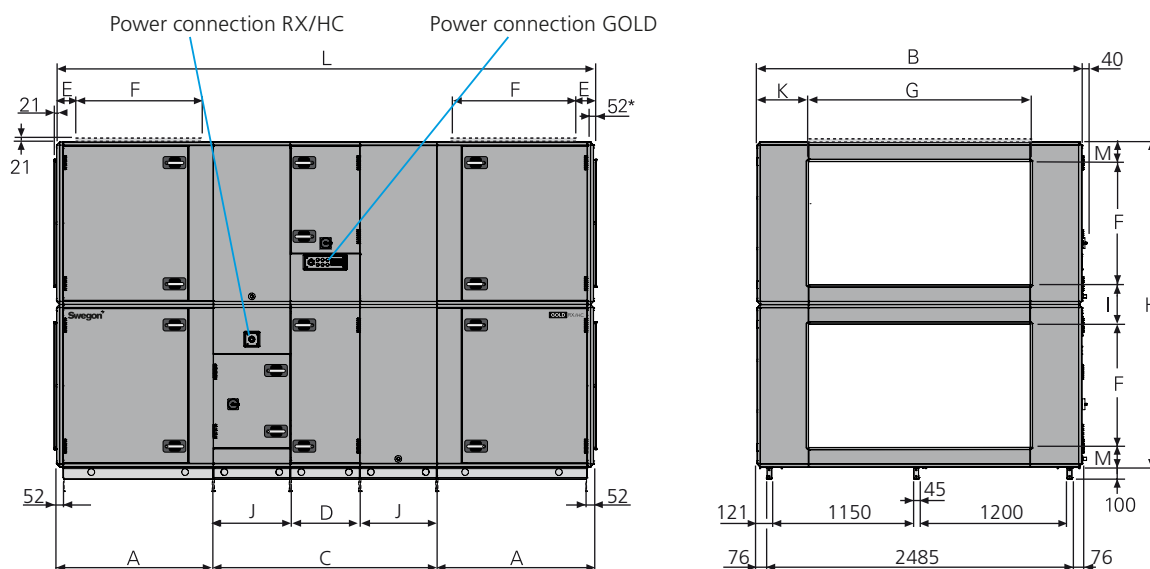

The diagram shows RX/HC integrated in a GOLD standard air handling unit set-up. The installation length for RX/HC corresponds to the C-measurement. Placement of the air handling unit sections, connection hood, drain pipe, etc. may vary depending on the selected variant.

If a water trap (accessory) is fitted, the air handling unit must be raised at least 50 mm to provide space for the water trap. Adjustable support feet (accessories) can be appropriately fitted to the base beams for this purpose.

* The air handling unit is supplied without end connection panel if a duct accessory housed in an insulated casing will be connected. The AHU can also be supplied with full face end connection panel (accessory).

Size	A	B	C	D	E	F	G	H	I	J	K	L	M	Weight, kg
070	1273,5	2637	1815	565	162	1000	1800	2640	320	625	418,5	4362	160	3322-3645

Division into sections for transport

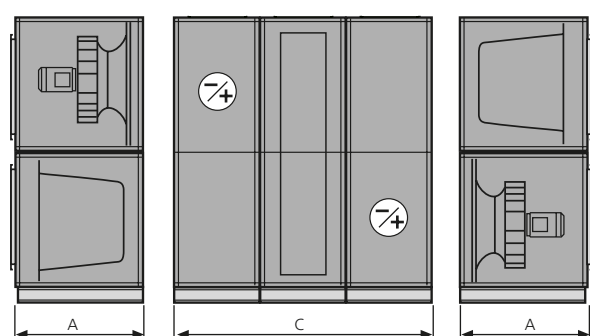

The unit can be divided into three sections at the building site.

Dimensions: See A and C in the table above.

Weight: A = 786-911 kg,
C = 1750-1823 kg.

In addition to this, the middle section (RX/HC) can be delivered in a variant with split refrigerant circuit. The RX/HC section is then delivered assembled from the factory, but can be divided into three units on site, see D and J in the table above. Assembly of the RX/HC section may only be performed by certified refrigeration technicians.

Complements and Accessories

GOLD RX/HC

Dimensions and weights

RX/HC 080

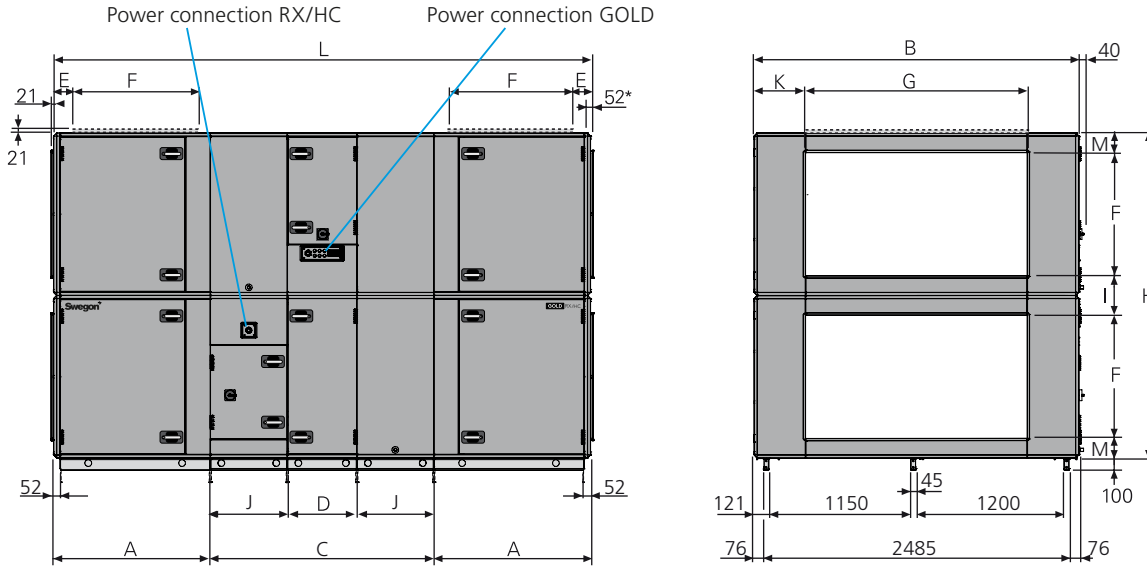

The diagram shows RX/HC integrated in a GOLD standard air handling unit set-up. The installation length for RX/HC corresponds to the C-measurement. Placement of the air handling unit sections, connection hood, drain pipe, etc. may vary depending on the selected variant.

If a water trap (accessory) is fitted, the air handling unit must be raised at least 50 mm to provide space for the water trap. Adjustable support feet (accessories) can be appropriately fitted to the base beams for this purpose.

* The air handling unit is supplied without end connection panel if a duct accessory housed in an insulated casing will be connected. The AHU can also be supplied with full face end connection panel (accessory).

Size	A	B	C	D	E	F	G	H	I	J	K	L	M	Weight, kg
080	1273,5	2637	1815	565	162	1000	1800	2640	320	625	418,5	4362	160	3426-3785

Division into sections for transport

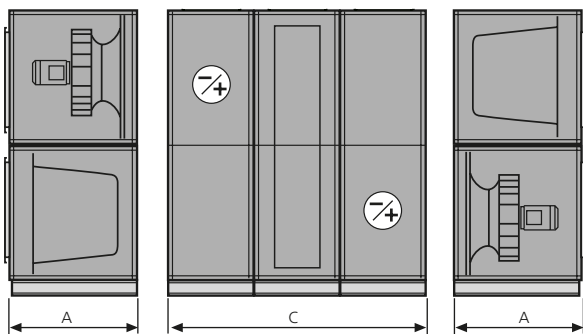

The unit can be divided into three sections at the building site.

Dimensions: See A and C in the table above.

Weight: A = 813-956 kg,
C = 1800-1873 kg.

In addition to this, the middle section (RX/HC) can be delivered in a variant with split refrigerant circuit. The RX/HC section is then delivered assembled from the factory, but can be divided into three units on site, see D and J in the table above. Assembly of the RX/HC section may only be performed by certified refrigeration technicians.

Plug and Play with COOL DX!



Dock the COOL DX to the GOLD air handling unit

The CoolDX Top cooling unit fits in well in the concept of the GOLD air handling unit and really stands for Plug and Play.

All the equipment is housed in one and the same unit and can be docked to the GOLD. The COOL DX can also be installed as a stand-alone unit.

In addition to the above, only an electric power supply and a communication cable (with quick-fit connector)



Dock the COOL DX Top on top of the GOLD RX Top air handling unit

between the COOL DX/COOL DX Top and the GOLD as well as the connection of drainage pipework are required.

The GOLD has ready-to-use cooling functions for controlling and regulating the COOL DX/COOL DX Top. This also includes communication via web or traditional performance monitoring systems.

The COOL DX/COOL DX Top thus means minimal investment for project designing, procurement and installation.

- Extremely quick and simple installation.
- Built-in control equipment operated from the GOLD.
- Variable comfort control or economy control in 3 steps.

- Ready for communication via the GOLD.
- Its location inside the GOLD prevents the extract air fan motor from being subject to high temperatures.

Economy or comfort control

Economy control

Cooling in 3 steps

When cooling is required, cooling compressor 1 starts up. On an increasing cooling load, cooling compressor 2 starts up and cooling compressor 1 is switched out. If the cooling load increases even more, both cooling compressors are started.

Advantage: Each cooling compressor is switched in and out in pace with the amount of cooling required and this shortens the overall in-operation period.

Consequence: Cooling in 3 steps

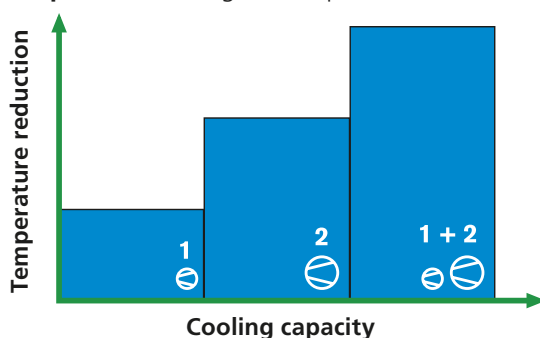

Cooling compressor ⊖ Heat exchanger

Comfort control (not COOL DX Top)

Cooling and variable temperature control

As a form of economy control but when there is a cooling load, the heat exchanger of the air handling unit is also activated and this controls the temperature within the cooling step.

Advantage: Variable control of the cooling capacity and uniform supply air temperature.

Consequence: Each cooling compressor operates for a longer period when cooling is needed.

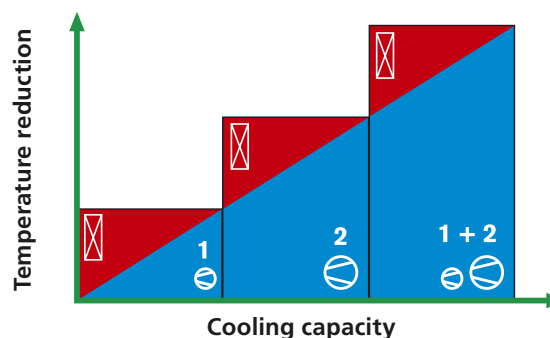

Complements and Accessories

COOL DX/COOL DX Top

General

The COOL DX/COOL DX Top is a complete cooling unit for comfort cooling in the air handling system.

The COOL DX is produced in seven sizes with cooling capacity from 10 to 134 kW. The seven sizes are capacity-wise matched to the size 007-080 GOLD air handling units.

The COOL DX Top is produced in three sizes with cooling capacity from 6.8 to 20.4 kW. On the basis of capacity, the three sizes are matched to the size 004 - 012 GOLD air handling units.

Mechanical Design

The COOL DX cooling unit is designed for installation against the outdoor air and exhaust air side of the GOLD unit.

Place the COOL DX Top cooling unit on top of the GOLD RX Top air handling unit

All electrical and control equipment is prewired and collected inside a common casing.

Composed of cover panels and inspection doors. The outer skin is made of galvanized sheet steel, re-painted in Swegon's own grey metallic paint (closest comparable RAL colour: 9007). The inner skin is made of aluminium-zinc plated sheet steel. Environmental Class C4. Panel thickness of 52 mm with intervening insulation consisting of mineral wool.

The cooling coil and condenser are fabricated of copper tubing and profiled aluminium fins.

The cooling unit is test run prior to delivery.

Control and regulation

The COOL DX/COOL DX Top cooling unit has a built-in control system.

Only an electric power supply and a communication cable are required for the transmission of information between the COOL DX/COOL DX Top and the GOLD control systems. The communication cable is supplied together with the unit. All in-operation status and other information is readily available for viewing in the hand-held terminal of the GOLD air handling unit.

The cooling capacity is controlled by operating one or both compressors. Cooling is controlled in 3 steps in binary mode.

On receiving an on/off control signal, compressor M1 starts up. On an increasing cooling load, compressor M2 starts at the same time that compressor M1 stops. If the cooling load increases even more, both compressors M1 and M2 operate.

Completely direct-acting system

The COOL DX/COOL DX Top has a completely direct-acting system. It has an evaporation coil for direct-evaporating refrigerant on the cold side and a condenser coil on the hot side.



COOL DX



COOL DX Top

Refrigerant

The COOL DX/COOL DX Top has double refrigerant circuits, which are charged with refrigerant on delivery. The volume of refrigerant for each size is tabulated in the Technical Data Table.

Type R410A refrigerant is used. At present, this refrigerant has no known influence on the ozone layer and no known future restrictions are anticipated.

Inspection of the installation, obligation to report and periodic leakage tracing must be carried out according to the F-Gas Regulation EU/517/2014 and associated local legislation, also refer to the separate Installation and Maintenance Instructions for COOL DX/COOL DX Top.

Duct connection

The end connection panel for outdoor and/or exhaust air is optional for the Cool DX cooling units. If an end connection panel is selected, slip-clamps (sizes 020-080) or rubber ring seals (sizes 008-012) are used for connection to the ducting. If no end connection panel has been selected, the profiled frame members on the cooling unit should be connected to the ducting across an adapter (not supplied by Swegon).

Connect the COOL DX Top to duct connections with rubber seal ring.

Complements and Accessories

COOL DX/COOL DX Top

Technical data

COOL DX

COOL DX Size	Capacity variant	Nom. air-flow m ³ /s	Min. air-flow m ³ /s	Nom. cooling capacity ¹⁾ (kW)	Nom. Power required (kW)	Refrigerant (kg)		Power supply	Weight excl. end conn. panel (kg)	Weight of each end conn. panel, if required ²⁾ (kg)
						Circuit 1	Circuit 2			
008	1	0.55	0.22	9.8	2.39	1,20	1,30	3-ph.+N, 400 V ±10%, 16 A	194	8
	2	0.70	0.3	13.9	4.33	1,20	1,30	3-ph.+N, 400 V ±10%, 20 A	215	8
012	1	0.85	0.35	15.4	3.95	1,50	1,70	3-ph.+N, 400 V ±10%, 20 A	260	10
	2	1.05	0.4	20.9	6.53	1,50	1,70	3-ph.+N, 400 V ±10%, 25 A	287	10
020	1	1.1	0.45	15.4	4.06	1,20	1,50	3-ph.+N, 400 V ±10%, 25 A	247	11
	2	1.3	0.5	23.3	5.73	2,50	2,80	3-ph.+N, 400 V ±10%, 25 A	287	11
	3	1.6	0.6	31.0	9.15	2,10	2,40	3-ph.+N, 400 V ±10%, 40 A	318	11
030	1	1.8	0.7	25.0	6.33	1,80	2,00	3-ph.+N, 400 V ±10%, 32 A	327	17
	2	2.0	0.8	35.8	9.34	3,00	3,20	3-ph., 400 V ±10%, 25 A	379	17
	3	2.4	1.0	46.2	13.5	2,90	3,30	3-ph., 400 V ±10%, 40 A	419	17
040	1	2,9	1,1	38,6	8,40	3,30	4,00	3-ph., 400 V ±10%, 25 A	498	22
	2	3,1	1,3	48,4	12,3	3,30	4,50	3-ph., 400 V ±10%, 40 A	506	22
	3	3,6	1,5	67,0	17,5	5,50	4,50	3-ph., 400 V ±10%, 50 A	559	22
060	1	3,9	1,5	56,2	11,8	4,50	5,50	3-ph., 400 V ±10%, 40 A	715	32
	2	4,1	1,6	66,7	17,1	5,00	5,20	3-ph., 400 V ±10%, 50 A	786	32
	3	5,0	2,0	97,5	26,3	6,00	7,50	3-ph., 400 V ±10%, 80 A	859	32
080	1	5,2	2,0	67,0	13,3	6,60	7,30	3-ph., 400 V ±10%, 50 A	852	38
	2	6,0	2,4	96,5	24,8	6,50	9,00	3-ph., 400 V ±10%, 80 A	979	38
	3	7,0	2,8	134,0	36,4	9,00	11,50	3-ph., 400 V ±10%, 100 A	1035	38

¹⁾ For an outdoor temperature of 26°C, 50% RH (capacity variant 1), 27°C, 50% RH (capacity variant 2) or 28°C, 50% RH (capacity variant 3), and an extract air temperature of 26°C. ²⁾ The first weight applies to a small end connection panel; the second weight applies to a large end connection panel. COOL DX can be supplied completely without end connection panels or with a maximum of 2 small and two large end connection panels depending on the variant selected.

COOL DX Top

COOL DX Top Size	Capacity variant	Nom. air-flow (m ³ /s)	Min. air-flow (m ³ /s)	Nom. cooling capacity ¹⁾ (kW)	Nom. power required (kW)	Refrigerant (kg)		Power supply	Weight (kg)
						Circuit 1	Circuit 2		
005	1	0.40	0.10	6.77	1.66	0.95	1.00	3-ph.+N, 400 V ±10%, 16 A	200
	2	0.55	0.20	9.30	2.48	1.02	1.03	3-ph.+N, 400 V ±10%, 20 A	200
008	1	0.55	0.22	9.31	2.38	1.15	1.20	3-ph.+N, 400 V ±10%, 20 A	280
	2	0.70	0.3	13.5	4.34	1.29	1.30	3-ph.+N, 400 V ±10%, 20 A	280
012	1	0.85	0.35	14.8	3.95	1.60	1.70	3-ph.+N, 400 V ±10%, 20 A	340
	2	1.05	0.40	20.4	6.69	1.75	1.92	3-ph.+N, 400 V ±10%, 25 A	340

¹⁾ For an outdoor temperature of 26°C, 50% RH (capacity variant 1) or 28°C, 50% RH (capacity variant 2), and an extract air temperature of 26°C.

Sizing in AHU Design

There are many factors that influence what size of cooling unit is required. For correct sizing we refer to our AHU Design air handling unit selection program.

Complements and Accessories

COOL DX/COOL DX Top

Electrical and control equipment

General

The COOL DX/COOL DX Top cooling unit is internally fully wired and trial run prior to delivery.

All electrical and control equipment is collected inside an electrical equipment cubicle inside the COOL DX/COOL DX Top.

The safety switch is positioned on the front panel of the cooling unit.

Power supply

The incoming power supply for 400 V (4-wire system for size 030, capacity variants 2 and 3, and sizes 040-080, all capacity variants, 5-wire system for other sizes) should be connected directly to the safety isolating switch.

Wire the electrical power supply connections according to the technical data table on the previous page. Use delayed fuses! In applications where automatic circuit breakers are used, the circuit breakers must have delta characteristic.

Control and regulation

A ready-to-use communication cable with quick connector for on/off switching, cooling capacity control as well as in-operation indication and alarms is used. The communication cable is supplied together with the unit.

Standards

The COOL DX/COOL DX Top is CE labelled in accordance with PED and the provisions of the EMC Directive for interference levels defined in SS-EN-50081-1 and SS-EN-61000-6-2 Standards (electromagnetic emissions in dwellings, office buildings, shops and similar environments as well as for immunity in industrial environments).

Applicable to installations in Sweden:

The unit meets the provisions of the ELSÄK-FS 1999:5 and SS-EN 60,204-1 and other applicable Swedish electrical safety standards and rules.

Hand-held micro terminal

Settings can be entered, readings can be viewed and possible alarms are displayed in the hand-held micro terminal of the GOLD air handling unit.

Complements and Accessories

COOL DX/COOL DX Top

Variants

COOL DX 008

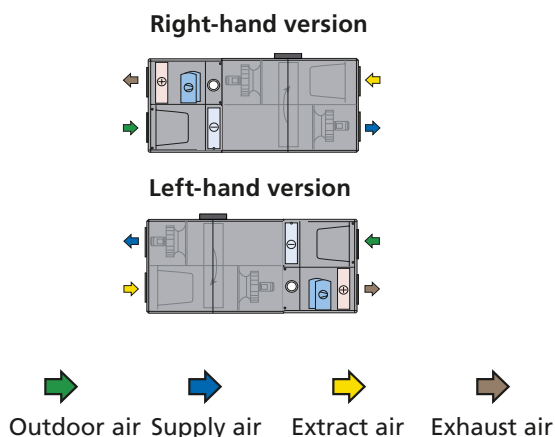

COOL DX 012-080

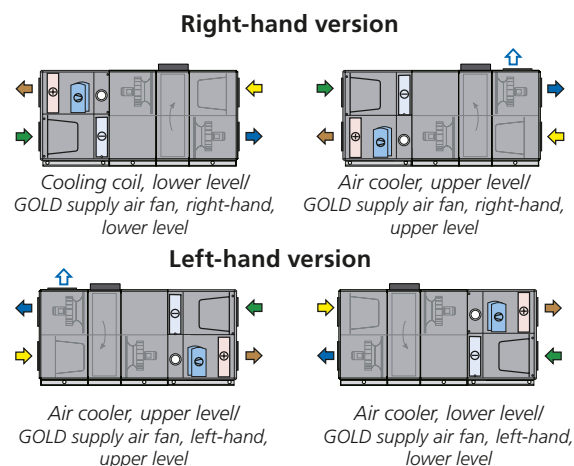

Installation Tips

The cooling unit can be positioned against the outdoor air/exhaust air side of the GOLD air handling unit: See the illustration above. The COOL DX cooling units can be docked directly to the GOLD air handling unit, with so-called full face connection (without end connection panels). The COOL DX can also be installed as a stand-alone unit. If you order a stand-alone COOL DX, select version D as a variant with end connection panels.

When positioning the cooling unit, bear in mind that it must be possible to open the inspection door as well as connect drainage pipework and power supply and control wiring without difficulty.

To drain the cooling coil

The cooling coil in the cooling unit is equipped with a condensate drain tray and a drainage connection (condensate forms on coil surfaces). The condensate discharge pipework must be connected across a water trap (accessory) to the drain connections of the cooling unit and must run with continuous slope to a drain gully.

Height adjustment to the height of the GOLD/water trap

COOL DX, size 008

In combination with the GOLD RX 008

The GOLD air handling unit can be mounted on base beams, a stand or some other form of foundation. Base beams and stands are available as accessories.

Appropriate base beams and stands are also available as accessories for the COOL DX. The base beams/stands are matched to one another in terms of height. The stands also provide space for accommodating a possible water trap in the lower level (right-hand unit version).

In combination with the GOLD PX 008

The air handling unit is supplied with base beams. A set of legs (accessory) can be mounted in the base beams.

Appropriate base beams and set of legs are also available as accessories for the COOL DX. The base beams/sets of legs are matched to one another in terms of height. The sets of legs also provide space for accommodating a possible water trap in the lower level (right-hand unit version).

COOL DX, sizes 012-080

The GOLD air handling unit and the COOL DX chiller are supplied with a 100 mm high base beam.

Applicable to a cooling coil in the lower level:

If a water trap (accessory) is fitted, the GOLD air handling unit and the chiller must be raised at least 50 mm to provide space for the water trap. Adjustable support feet (accessories) can be appropriately fitted to the base beams for this purpose.

Supply air filter

The COOL DX is supplied without supply air filter. Consequently, the supply air filter in the GOLD unit should be dismantled and moved to the COOL DX.

COOL DX/COOL DX Top

Variants

COOL DX Top, 005 - 012

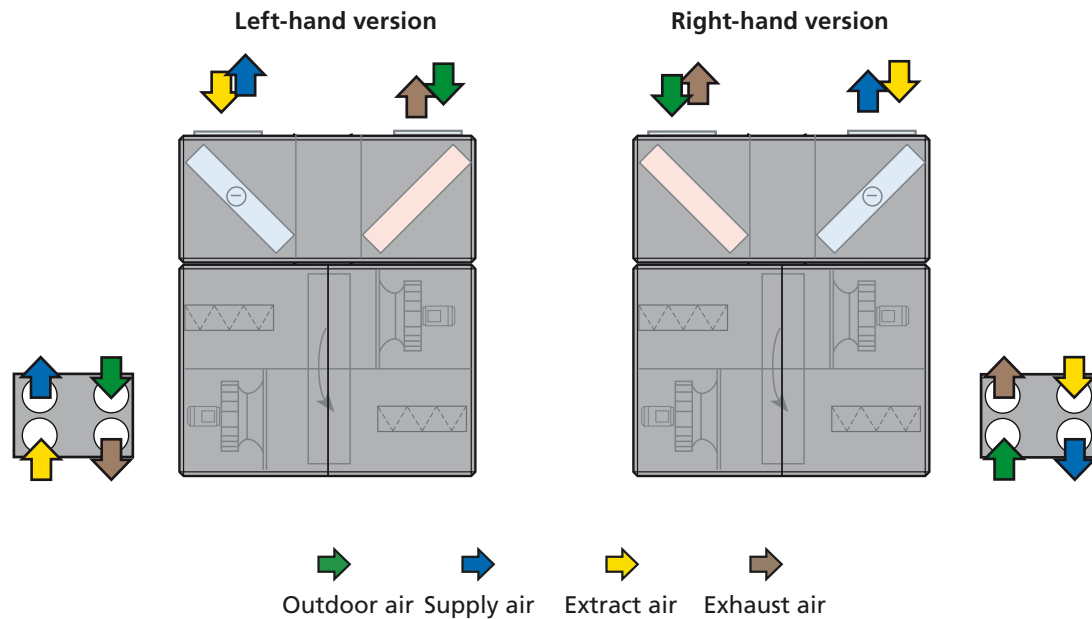

Installation tips

The cooling unit can be positioned on top of a GOLD RX Top unit equipped with a docking module. See illustration above.

When positioning the cooling unit, bear in mind that it must be possible to open the inspection door and connect the drainage pipework and power supply without difficulty.

To drain the air cooler

The air cooler in the cooling unit is equipped with a condensate drain tray and a drainage connection (condensate forms on air cooler coil surfaces). The condensate discharge pipework must be connected across a water trap (accessory) to the drain connections of the cooling unit and must run with continuous slope to a drain gully.

Complements and Accessories

COOL DX/COOL DX Top

Dimensions

COOL DX 008

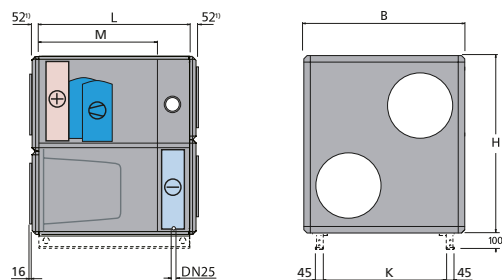

Base beams are accessories.

¹⁾ End connection panel, optional.

Size	L	B	H	K	M	Duct connection ²⁾
008	900	995	1085	749	709	Ø 400

²⁾ For particulars on how to arrange the duct connections, see the corresponding GOLD air handling unit

COOL DX 012

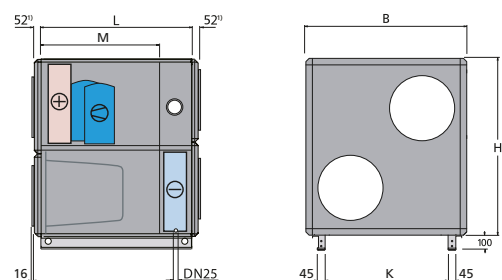

¹⁾ End connection panel, optional.

Size	L	B	H	K	M	Duct connection ²⁾
012	900	1199	1395	953	709	Ø 500

²⁾ For particulars on how to arrange the duct connections, see the corresponding GOLD air handling unit

COOL DX 020, 030, 040, 060, 080

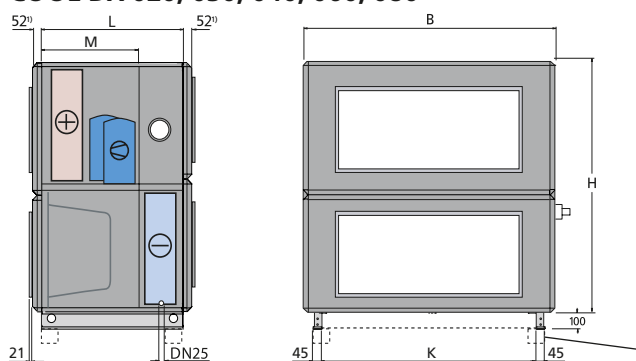

¹⁾ End connection panel, optional.

Size	L	B	H	K	M	Duct connection ²⁾
020	900	1400	1551	1154	709	1000 x 400
030	900	1600	1811	1354	709	1200 x 500
040	1100	1990	2159	1744	884	1400 x 600
060	1100	2318	2288	2072	884	1600 x 800
080	1100	2637	2640	2395	884	1800 x 1000

²⁾ For the locations of the duct connections, see the corresponding GOLD air handling unit

COOL DX Top, 005, 008, 012

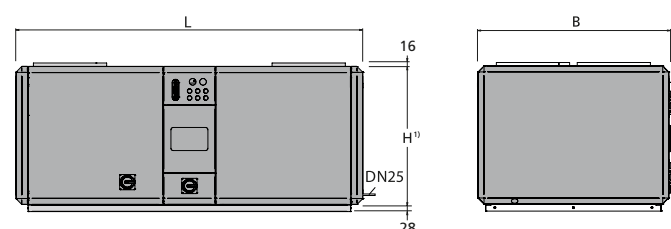

¹⁾ When calculating the total plant height, use the height of the GOLD air handling unit + the H dimension from the illustration above.

Size	L	B	H	Duct connection ²⁾
005	1500	825	600	Ø 315
008	1600	995	600	Ø 400
012	1860	1199	600	Ø 500

²⁾ For particulars of the locations of the duct connections, see the corresponding GOLD air handling unit

Reversible chiller for direct expansion, Echos+ LE, LE/HP

Echos+ in version LE/HP is a energy-efficient air-cooled and reversible chiller with direct expansion.

The chiller has a frequency-controlled compressor that steplessly operates at exactly the right speed for producing just the right evaporation temperature to meet the immediate need. This means significant energy savings compared with a traditional compressor controlled only by On or Off switching.

The chiller is controlled in a simple way from a GOLD unit via SMART Link DX.

Versions

LE: For direct expansion

LN: Sound attenuated

LE/HP: Reversible heat pump

Quick facts

5 sizes with rated cooling capacity up to 26 kW

Speed-regulated scroll compressor with DC inverter, type R410A refrigerant

Condenser fan control as standard

Electronic expansion valve as standard

4-way reversing valve as standard to version HP

Energy class A as standard

Smart and simple control via the GOLD

Control via SMART Link DX

The Echos+ has integrated SMART Link technology. This enables control of the chiller from the GOLD air handling unit.

The Echos+ is controlled from the GOLD via internal communication, where the rotational speed of the chiller compressor is regulated to meet immediate needs.

The Echos+ is reversible and can therefore also be used for reheat in winter. Up to three units can be connected each with its own circuit to the cooling/heating coil for the required cooling/heating demand.

The integrated control system makes the installation very simple. Only one data cable is needed between the GOLD and the Echos+.

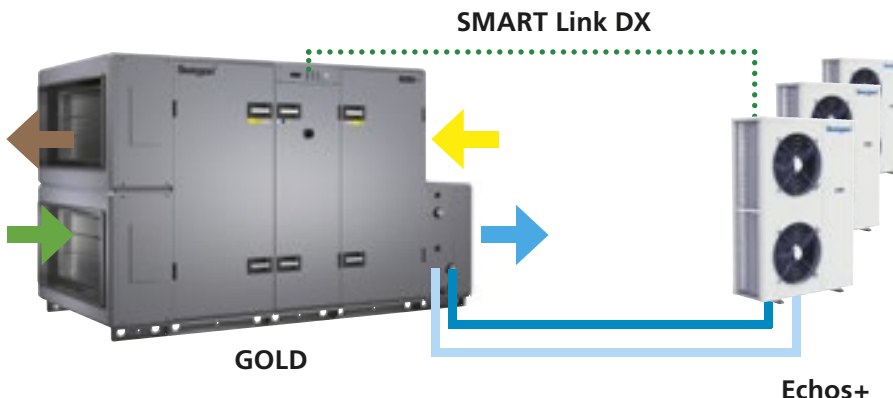

Complements and accessories

Echos+ LE/HP chiller

Technical data

Echos+ LE/HP		9	15	20	26	30
Rated cooling capacity (ambient temperature 35°C, evaporation temperature 7.5°C, compressor speed 90 rps)	kW	6,9	12,1	18,2	25,0	29,6
Power consumption, cooling (compressor + fans)	kW	1,9	3,2	5,1	6,9	8,2
EER (to EN 14511-3:2011)		3,69	3,74	3,59	3,63	3,61
Rated heating capacity (ambient temperature 7°C, condensation temperature 7.5°C, compressor speed 90 rps)	kW	7,0	12,5	18,7	24,4	28,9
Power consumption, heat (compressor + fans)	kW	1,76	2,95	4,68	6,20	7,44
COP (to EN 14511-3:2011)		3,98	4,22	3,99	3,94	3,88
Length	mm	925	925	1105	1305	1305
Width	mm	375	375	505	505	505
Height	mm	1350	1350	1385	1585	1585
Weight in operation	kg	146	149	217	262	268
Power supply		1x230V	3+N x 400 V			

Large operation range

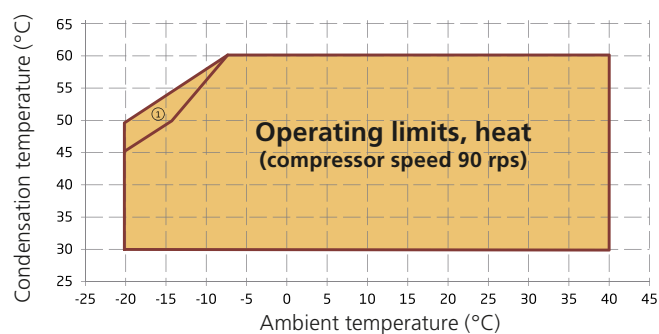
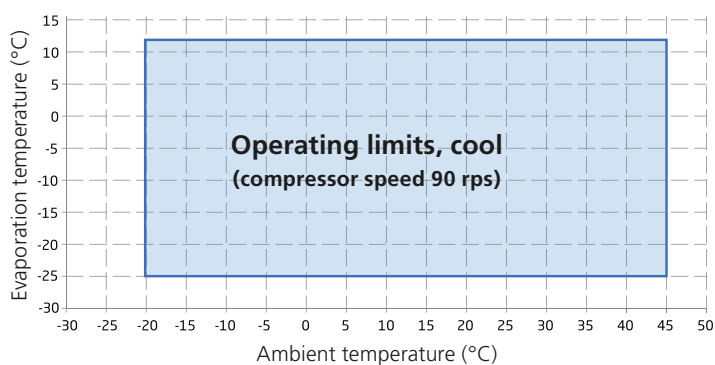

1. In this area, the compressor can be regulated for controlling the condensation temperature

Complements and Accessories

Blue Box Chiller/Heat pump

General

A wide range of Swegon’s chillers/heat pumps of Blue Box type are available. See separate catalogue.

Blue Box chillers/heat pumps are of the highest quality and are leading products in their segment.

AQUA Link

The AQUA Link hydraulic module supplies both air handling units and comfort modules with cooling power. See separate catalogue.

Control and regulation

The BlueBox unit control system includes functions intended for controlling the times, temperatures, etc. and also for reading the alarms and settings of a Blue Box chiller/heat pump via the hand-held micro terminal and web page in a GOLD air handling unit.

An optimisation function for waterborne chillers/heat pumps is also incorporated into the GOLD air handling unit’s control system. The optimisation function optimizes the position of the valve for the water coil, so that the valve always strives to be fully open. The water temperature is controlled instead and this saves energy.

See separate Guide to the SMART Link Functions for waterborne chillers/heat pumps and the Guide to the SMART Link DX Functions respectively for the Echos+ DX chillers/ heat pumps.

Installation

The installation work is quick and simple compared with other systems.

All the necessary control functions are ready to be activated.

One supplier for all the equipment



Blue Box chiller

Ex: OXFORD



Blue Box heat pump

Ex: MAROON 2 HWS



AQUA Link

Complements and Accessories

Unit sections

TCBR Air recirculation section

The air recirculation section is an extra unit section that has a motor-driven damper (on/off or modulating) in the intermediate level.

The air recirculation section is available for the size 011 and larger GOLD RX, PX and CX units. The air recirculation section is also available for GOLD RX/PX size 004-008 in split version. The GOLD PX/CX cannot be used for the ReCO function₂.

Included in the delivery:

Air recirculation section. Mounted actuator for damper. Necessary extension wiring for the supply air fan.

Delivery version:

Sizes 004-080: The air recirculation section is fitted to at least one of the other unit sections, see the section entitled: Air Handling Unit/Delivery Configuration RX/PX/CX, sizes 004-080.

Size 120: The air recirculation section is supplied as an individual item in two sections.

Additional equipment required:

Depending on how the air recirculation section is to be used, it may also be necessary to install extra sensors for reading e.g. the pressure, room temperature or CO₂ content, heating and/or cooling coil temperatures and the status of shut-off dampers for exhaust air and outdoor air.

Work to be carried out at the building site:

Sizes 004-080: Fitting together/splitting of unit sections to the extent required.

Size 120: Assembly of the air recirculation section to become one unit. The air recirculation section is then fitted together with the other unit sections.

Operation:

Recirculation, on/off: Can be used when it is desirable to heat an unoccupied room with recirculated air; an economic solution for e.g. factory buildings, shopping centres, etc.

The intermittent night-time heating function stops the extract air fan and heat recovery, closes the shut-off dampers for outdoor air and exhaust air and opens the damper in the air recirculation section. See also previous section "Control Functions".

Recirculation, modulating: Can be used for the demand-controlled and economical operation of fans, heating and cooling, especially in buildings in which the load conditions vary.

The patent-pending ReCO function₂ adjusts the air quality (in response to signals from CO₂ sensors) and temperature by variably controlling the shut-off dampers and the damper in the air recirculation section as well as the speed of the fans. See also previous section "Control Functions".

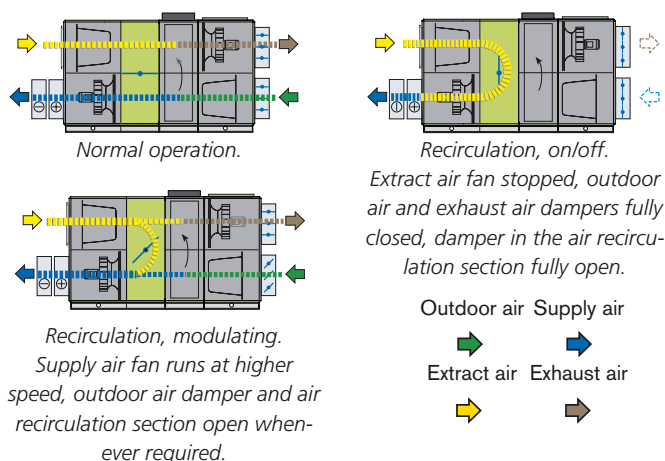

The ReCO function₂ requires the accessory, complete set for control of the mixing function (ReCO₂), TBLZ-2-51. Pressure sensors and IQlogic+ are included. Air quality sensor must be ordered separately.

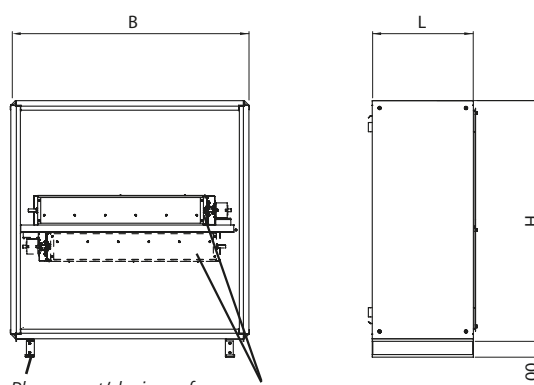

Placement/design of the base beam, see the equivalent size of the GOLD air handling unit.

Depending on the version, the damper can be mounted in the upper or lower level (for GOLD size 120 the damper is always mounted in the upper level).

For GOLD	B	H	L	kg
004/005	825	920	400	50
007/008	995	1085	400	57
011/012	1199	1295	565	90
014/020	1400	1551	565	103
025/030	1600	1811	565	118
035/040	1990	2159	565	142
050/060	2318	2288	565	168
070/080	2637	2640	565	195
100/120	3340	3340	1070	547

Complements and accessories

Unit sections

Solutions for fire bypass

The air bypass section is used when you want the extract air to bypass the heat exchanger and filter, e.g. as a component in a system for smoke extraction. See the example for respective variants/sizes. The fans of the air handling unit are tested for, and can manage operation for one hour at 70°C.

The air bypass section is available for GOLD RX/PX size 011-080. The air bypass section is also available for GOLD RX/PX sizes 004-008 and GOLD SD extract air handling unit sizes 004-012 in split version.



GOLD RX, sizes 004-080

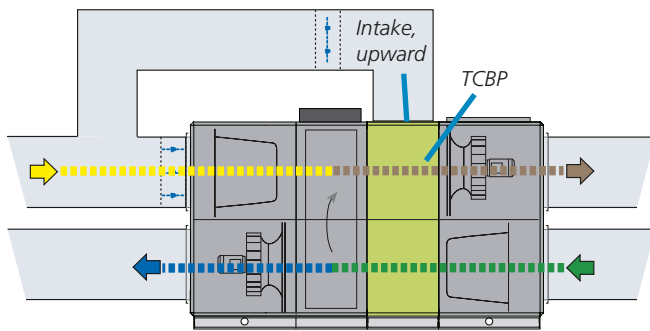

Solution for fire bypass (upward) for GOLD RX 004-080.

Necessary components required (apart from GOLD units):
 The TCBP air bypass section is supplied fitted together with at least one of the other unit sections, see the section entitled: Description of the Air Handling Unit/Delivery Configuration RX/IPX/CX, sizes 004-080.
 The required splitting/fitting together of unit sections is performed at the building site.
 Extra dampers may be required depending on the application.
 Should be controlled via TRITON control and supervisory unit or the like.

GOLD PX, sizes 004-040

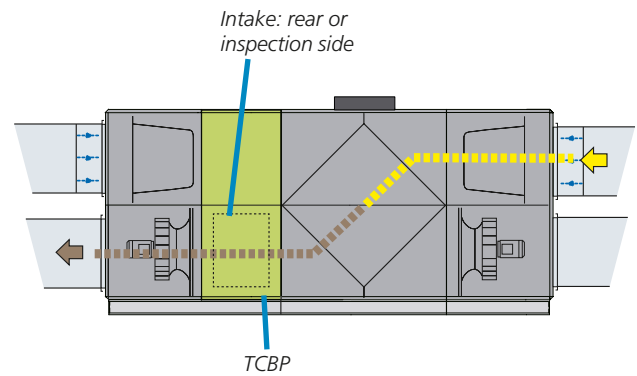

Solution for fire bypass (rear, inspection side or upward) for GOLD PX 004-040.

Necessary components required (apart from GOLD units):
 The TCBP air bypass section is fitted together with at least one of the other unit sections, see the section entitled: Description of the Air Handling Unit/Delivery Configuration RX/IPX/CX, sizes 004-080.
 Required splitting/fitting together of unit sections is performed at the building site.
 Extra dampers may be required depending on the application.
 Should be controlled via TRITON control and supervisory unit or the like.

GOLD SD extract air handling unit, sizes 004-012

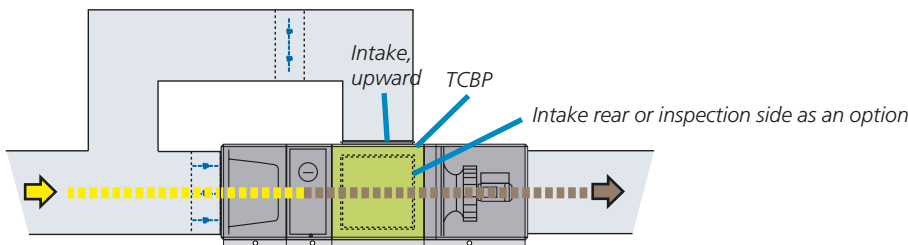

Solution for fire bypass (upwards, back or inspection side) for GOLD SD 004-012 extract air handling unit in split version.

Necessary components required (apart from GOLD units):
 Air bypass section, TCBP.
 The air handling unit can be supplied as one single unit or in an optional division of sections.
 Required splitting/fitting together of unit sections is performed at the building site.
 Extra dampers may be required depending on the application.
 Should be controlled via TRITON control and supervisory unit or the like.

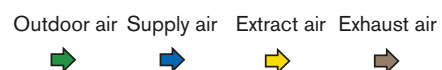

Complements and accessories

Unit sections

Air bypass section, TCBP, intake upward

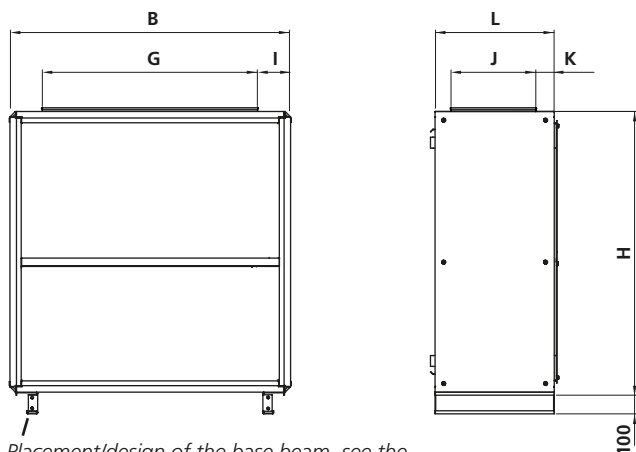

Placement/design of the base beam, see the equivalent size of the GOLD air handling unit.

For GOLD	B	H	L	G	I	J	K	kg
004/005	825	920	400	500	140	300	30	42
007/008	995	1085	400	650	150	300	30	49
011/012	1199	1295	565	1000	100	400	82.5	87
014/020	1400	1551	565	1000	200	400	82.5	103
025/030	1600	1811	565	1200	200	400	82.5	112
035/040	1990	2159	565	1400	295	400	82.5	123
050/060	2318	2288	565	1600	359	400	82,5	168
070/080	2637	2640	565	1800	418,5	400	82,5	246

Air bypass section, TCBP-xxxx, rear intake or on inspection side (GOLD PX)

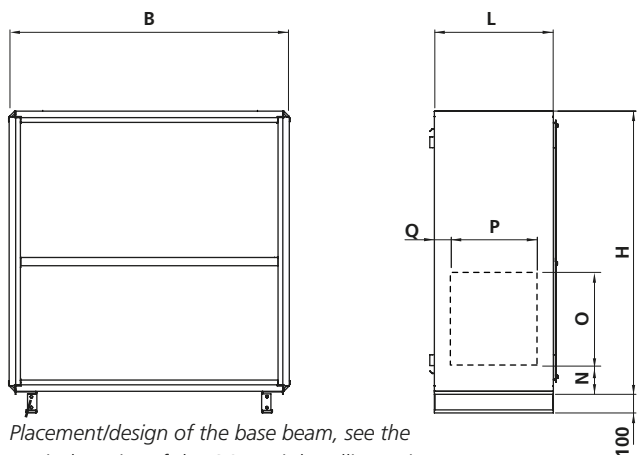

Placement/design of the base beam, see the equivalent size of the GOLD air handling unit.

For GOLD	B	H	L	N	O	P	Q	kg
004/005	825	920	400	77	300	300	30	47
007/008	995	1085	400	130	300	300	30	56
011/012	1199	1295	565	110	500	400	82.5	70
014/020	1400	1551	565	110	500	400	82.5	85
025/030	1600	1811	565	100	600	400	82.5	96
035/040	1990	2159	565	110	800	400	82.5	123

Air bypass section TCBP, intake: upward, rear or inspection side (GOLD SD)

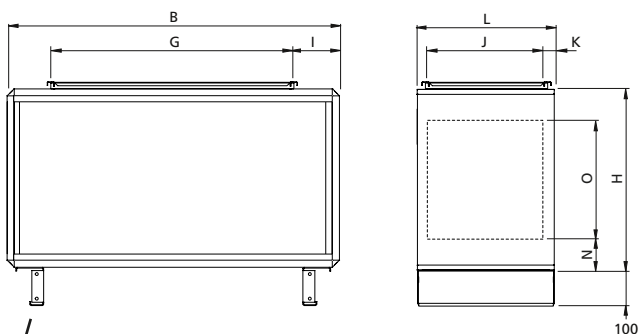

Placement/design of the base beam, see the equivalent size of the GOLD air handling unit.

For GOLD	B	H	L	G	I	J	K	N	O	kg
004/005	825	460	400	500	162.5	300	50	80	300	25-26
007/008	995	542.5	400	650	173	300	50	121	300	30-32
011/012	1199	647.5	565	1000	99.5	400	82.5	74	500	43-45

Complements and accessories

Unit sections

Smoke extraction adapter

The air bypass section is used when you want the extract air to bypass the heat exchanger and filter, e.g. as a component in a system for smoke extraction. See the example for respective variants/sizes.

The fans of the air handling unit are tested for, and can manage operation for one hour at 70°C.

The smoke extraction adapter is designed for use with GOLD PX, size 004-040.

Example

Normal operation.

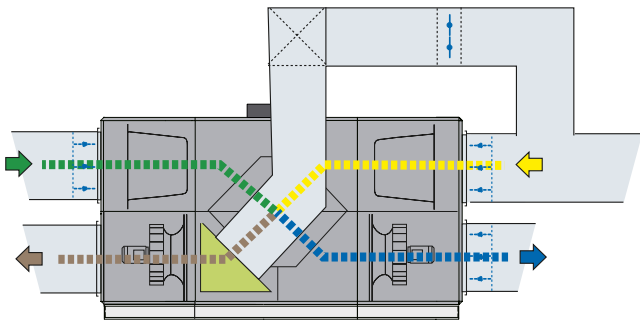

The extract air is routed to bypass the heat exchanger and filter

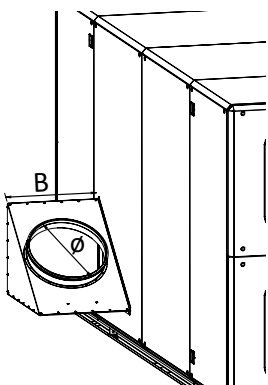
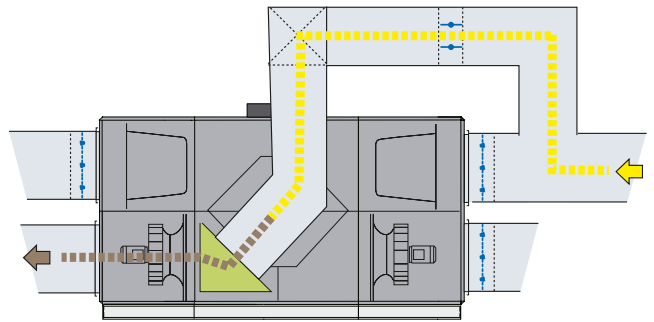

For GOLD	B	ø
004/005	320	250
007/008	385	315
011/012	477	400
014/020	477	400
025/030	577	500
035/040	700	630

Complements and accessories

Unit sections

TCRS duct crossover section

The duct crossover section for GOLD PX units is designed for use when you need to have the extract air fan and/or the supply air fan in the upper level. This may be necessary if space available is restricted or for example when replacing older AHUs with new ones that have fans in the upper level.

It is also possible to use the duct crossover section as a fire bypass.

The duct crossover section is available for GOLD PX size 011-040. The duct crossover section is also available for GOLD PX size 004-008 in split version.

Delivery version:

The duct crossover section is fitted to at least one of the other unit sections, see the section entitled: Description of the Air Handling Unit/Delivery Configuration RX/PX/CX, sizes 004-080.

Work to be carried out at the building site:

Fitting together/splitting of unit sections to the extent required.

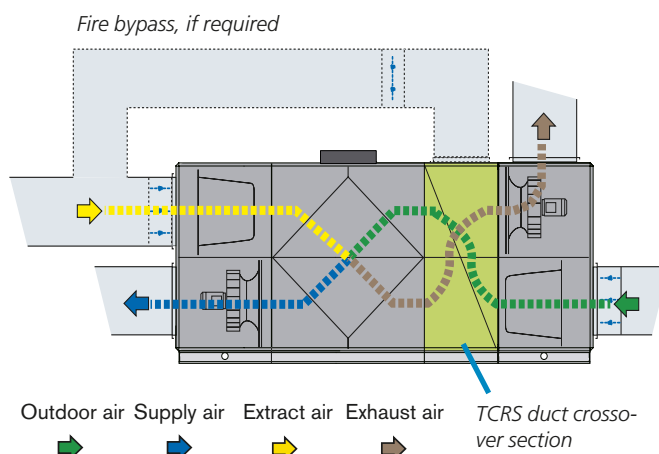

For GOLD	B	H	L	kg
004/005	825	920	565	66
007/008	995	1085	625	84
011/012	1199	1295	750	120
014/020	1400	1551	750	146
025/030	1600	1811	750	169
035/040	1990	2159	750	248

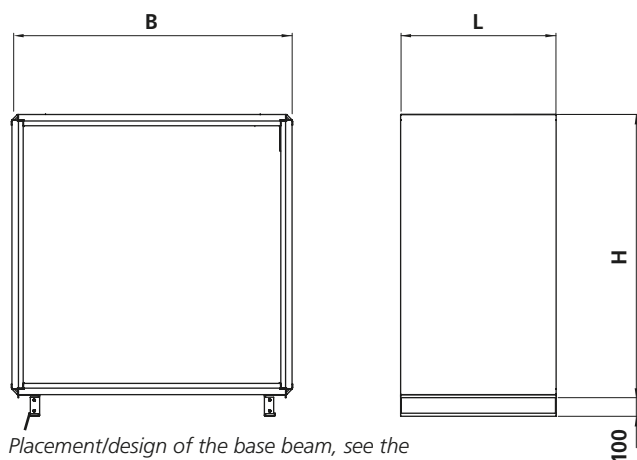

Placement/design of the base beam, see the equivalent size of the GOLD air handling unit.

Duct connection dimensions for fire bypass, if required

The illustration shows the Duct crossover section viewed from above.

TCRS 005, 020

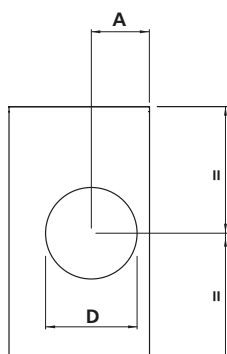

For GOLD	A	D
004/005	210	315
007/008	250	400
011/012	300	500
014/020	300	500

TCRS 030, 040

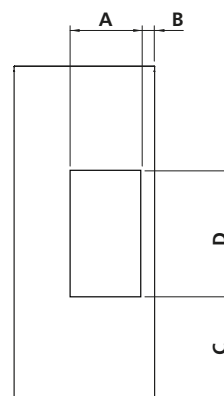

For GOLD	A	B	C	D
025/030	400	78	450	700
035/040	506	74	592	806

Complements and accessories

Unit sections

TCFE multisection

The multisection is an extra unit section, available in two lengths, with intermediate deck and optional combinations of cover panels/inspection doors on the inspection side, see illustrations on the next page. The cover panels are easy to dismantle.

Up to two multisections can be used in one air handling unit.

The multisection is available for the size 011 and larger GOLD RX, PX and CX units. The multisection is also available for GOLD RX/PX size 004-008 in split version. The multisection can be located between the other unit sections of the GOLD unit. See example below.

The multisection is available, as a special version, with installed accessories from the factory, for example an air heater/air cooler, dampers, etc..

Delivery version:

Sizes 004-080: The multisection is fitted to at least one of the other unit sections, see the section entitled: Description of the Air Handling Unit/Delivery Configuration RX/PX/CX, sizes 004-080.

Size 120: The multisection is supplied as an individual item in two sections.

Work to be carried out at the building site:

Sizes 004-080: Fitting together/splitting of unit sections to the extent required.

Size 120: Assembly of the multisection to become one unit. The multisection is then fitted together with the other unit sections.



Example

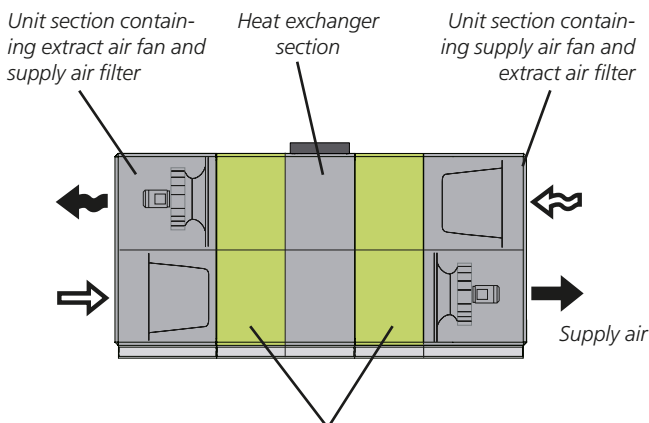

Up to two multisections can be used for one air handling unit. The illustration shows possible locations of the multisection.

Complements and accessories

Unit sections

Possible combinations, cover panels/inspection doors

Multisection, short (565 mm)

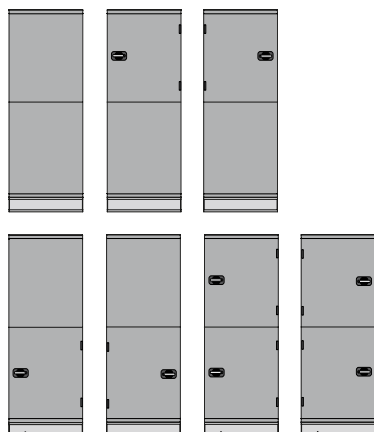

Multisection, long (850 mm)

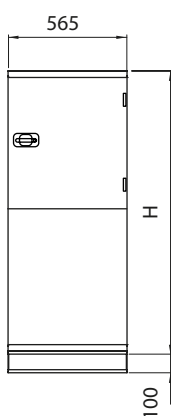
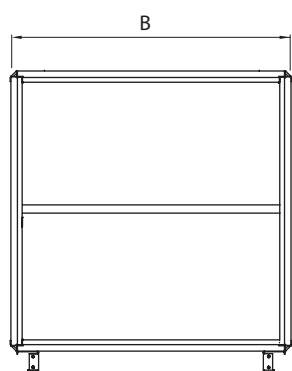
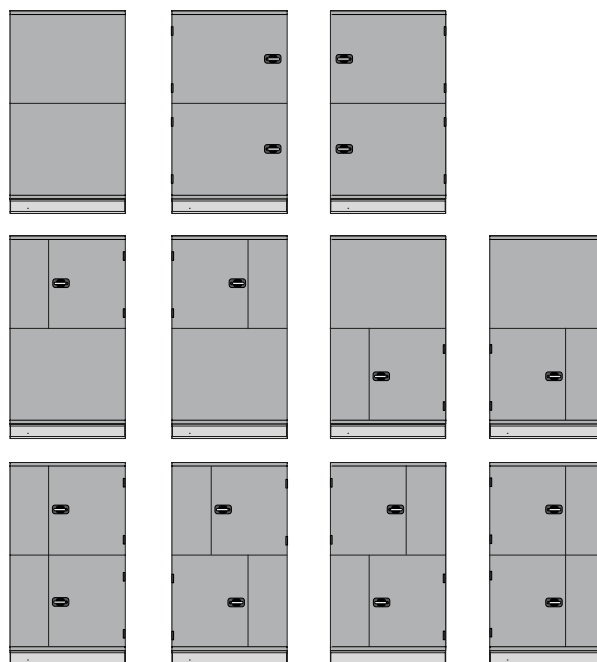

Placement/design of the base beam, see the equivalent size of the GOLD air handling unit.
The possible combinations of cover panels/inspection doors, see above.

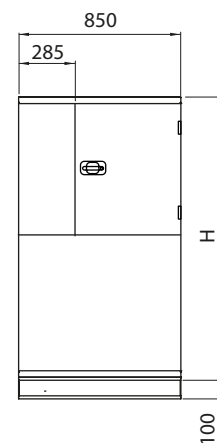
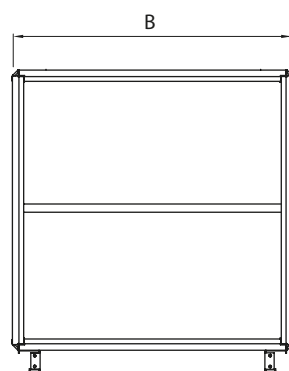

Placement/design of the base beam, see the equivalent size of the GOLD air handling unit.

For GOLD	B	H	kg
004/005	825	920	74
007/008	995	1085	77
011/012	1199	1295	90
014/020	1400	1551	104
025/030	1600	1811	119
035/040	1990	2159	143
050/060	2318	2288	189
070/080	2637	2640	258
100/120	3340	3340	492

For GOLD	B	H	kg
004/005	825	920	110
007/008	995	1085	120
011/012	1199	1295	142
014/020	1400	1551	167
025/030	1600	1811	189
035/040	1990	2159	202
050/060	2318	2288	243
070/080	2637	2640	347
100/120	3340	3340	640

Complements and Accessories

Duct accessories, uninsulated

Common for duct accessories

The duct accessories must be positioned outside the GOLD unit in the ductwork. The unique Wing+ fans in the GOLD air handling unit also make it possible to connect duct accessories directly to the duct connections of the air handling unit without pressure losses or non-uniform air distribution.

GOLD with standard end connection frame:

The duct accessories for GOLD sizes 004/005, 007/008 and 011/012 are fitted with a rubber ring seal.

The duct accessories for GOLD sizes 014/020, 025/030, 035/040, 050/060, 070/080 and 100/120 are equipped with connection frames for slip-clamp jointing (slip-clamps must be ordered separately).

Type METU connection frames are available as accessories. Insulating, if required, must be done at the site.

GOLD with full face connection frame:

Full face connection frames are available as accessories for further reduction of the pressure drop in the ventilation system. See the section on Mechanical equipment.

The duct accessories are equipped with connection frame for slip-clamp jointing (slip clamps must be ordered separately). Insulating, if required, must be done at the site.

Other particulars for sizing can be computed in the AHU Design air handling unit selection program.

Complements and Accessories

Duct accessories, uninsulated

TBSA Dampers

The TBSA 000-031, 000-040, 060-030 and 080-040 dampers are used as shut-off dampers or boosting dampers. The dampers of other sizes can also be used for other applications, such as an outdoor air damper for the ReCO₂ control function.

Shut-off dampers are normally used if the air handling unit is idle during some period, for example at night, or if a water coil without anti-frost protection is used.

Can be mounted in a horizontal or vertical duct.

Complete with damper actuator for 24 V. The actuator can be selected with spring return or on/off actuation. TBSA 000-050 and TBSA 100-040 – 250-080 are also available with an actuator of modulating type with spring return.

Technical data

Circular dampers made of galvanised sheet steel, rectangular dampers made of aluminium-zinc plated sheet steel. Tightness class 3 to EN 1751.

Installation

Wire the control and power supply cables to the appropriate wiring terminal on the air handling unit.



GOLD with standard end connection frame:
 TBSA 100-040, matches GOLD sizes 014, 020
 TBSA 120-030, matches GOLD RX/IPX Top sizes 014, 020 (for air intake)
 TBSA 120-050, matches GOLD sizes 025, 030
 TBSA 140-030, matches GOLD RX/IPX Top sizes 025, 030 (for air intake)
 TBSA 140-060, matches GOLD sizes 035, 040
 TBSA 160-080, matches GOLD sizes 050, 060
 TBSA 180-100, matches GOLD sizes 070, 080
 TBSA 240-120, matches GOLD sizes 100, 120
 (for air intake resp. fan outlet for forward air discharge)
 TBSA 250-080, matches GOLD sizes 100, 120
 (for fan outlet for upward air discharge)

GOLD with full face connection frame (accessory TBXZ):
 TBSA 060-030, matches GOLD sizes 004, 005
 TBSA 080-040, matches GOLD sizes 007, 008
 TBSA 100-040, matches GOLD sizes 011, 012
 TBSA 120-050, matches GOLD sizes 014, 020
 TBSA 140-060, matches GOLD sizes 025, 030
 TBSA 160-080, matches GOLD sizes 035, 040
 TBSA 180-100, matches GOLD sizes 050, 060
 TBSA 240-120, matches GOLD sizes 070, 080

GOLD with standard end connection frame:
 TBSA 000-031, is compatible with GOLD sizes 004, 005
 TBSA 000-040, is compatible with GOLD size 007, 008
 TBSA 000-050, is compatible with GOLD size 011, 012

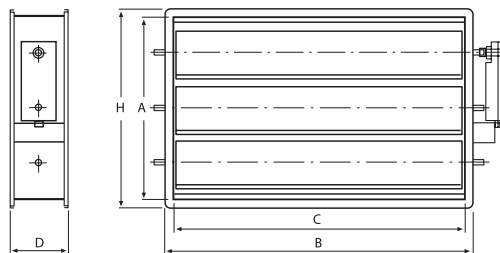
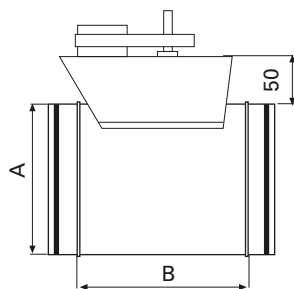

TBSA	A	B	kg
2-000-031	∅ 315	140	5
2-000-040	∅ 400	210	7
2-000-050	∅ 500	210	8

TBSA	A	B	C	D	H	kg
4-060-030	300	640	600	220	340	10
4-080-040	400	840	800	220	440	15
6-100-040	400	1040	1000	220	440	20
1-120-030	300	1240	1200	120	340	11
6-120-050	500	1240	1200	220	540	25
1-140-030	300	1440	1400	120	340	13
6-140-060	600	1440	1400	220	640	32
6-160-080	800	1640	1600	220	840	42
4-180-100	1000	1840	1800	220	1040	63
4-240-120	1200	2440	2400	220	1240	105
4-250-080	800	2540	2500	220	840	93

Complements and Accessories

Duct accessories, uninsulated

TBDA Unit silencer

TBDA 000-031, 000-040 and 000-050

Sound attenuators TBDA 000-031, 000-040 and 000-050 are circular sound attenuators for GOLD sizes 004–012 with standard end connection frame and are intended for installation in the ductwork.

Technical data

Galvanized sheet steel.

Sound attenuating material consisting of 100 mm thick long-fibred glass wool slabs that offer excellent sound attenuation, especially in the mid-frequencies. Glass wool covered with a layer of EUROLON that withstands substantially higher air velocities and mechanical strain than staple fibre. Sound attenuating material covered with perforated sheet steel outside the EUROLON layer.

Installation

Provision for inspection and cleaning must be guaranteed.



GOLD with standard end connection frame:

TBDA 000-031, is compatible with GOLD sizes 004, 005

TBDA 000-040, is compatible with GOLD size 007, 008

TBDA 000-050, is compatible with GOLD size 011, 012

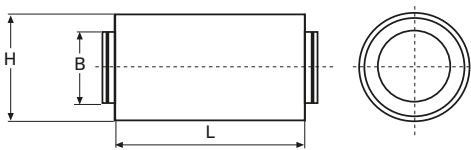

TBDA	B	H	L	kg
1-000-031	315	520	915	19,5
1-000-040	400	600	1200	29,5
1-000-050	500	700	1200	63

Complements and Accessories

Duct accessories, uninsulated

TBDA Unit silencer

TBDA 060-030 to 240-120

Sound attenuators TBDA 060-030 to 240-120 are rectangular sound attenuators for the GOLD sizes 004–120 and are intended for installation in the ductwork or directly to air handling units with standard end connection frames or full face connection frames.

Technical data

Galvanized sheet steel.

Sound absorption material of type Cleanolon-AL. Cleanolon-AL consists of mineral wool covered with perforated aluminium foil. Type approved with regard to suitability for cleaning, emissions and fibre entrainment. The material conforms to the provisions of Surface Layer Class 1 (the highest class). Type approved with regard to cleanability, emissions and fibre entrainment. The material conforms to the provisions of Surface Layer Class 1 (the highest class).

Installation

Provision for inspection and cleaning must be guaranteed.



TBDA-1060-030
TBDA-1-080-040
TBDA-1-100-040
TBDA-1-120-050
TBDA-1-140-060
TBDA-1-240-120

TBDA-1-160-080
TBDA-1-180-100



GOLD with standard end connection frame:

- TBDA 100-040, matches GOLD sizes 014, 020
- TBDA 120-050, matches GOLD sizes 025, 030
- TBDA 140-060, matches GOLD sizes 035, 040
- TBDA 240-120, matches GOLD sizes 100, 120

GOLD with full face connection frame (accessory TBXZ):

- TBDA 060-030, matches GOLD sizes 004, 005
- TBDA 080-040, matches GOLD sizes 007, 008
- TBDA 100-040, matches GOLD sizes 011, 012
- TBDA 120-050, matches GOLD sizes 014, 020
- TBDA 140-060, matches GOLD sizes 025, 030
- TBDA 240-120, matches GOLD sizes 070, 080

GOLD with standard end connection frame:

- TBDA 160-080, matches GOLD sizes 050, 060
- TBDA 180-100, matches GOLD sizes 070, 080

GOLD with full face connection frame (accessory TBXZ):

- TBDA 160-080, matches GOLD sizes 035, 040
- TBDA 180-100, matches GOLD sizes 050, 060

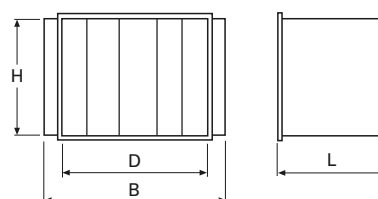
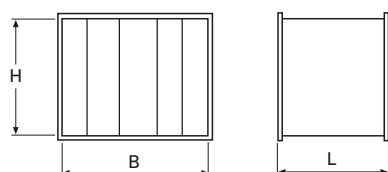

TBDA	B	H	L	kg
1-060-030	600	300	650	13
1-080-040	800	400	650	22
1-100-040	1000	400	650	26
1-120-050	1200	500	650	33
1-140-060	1400	600	650	39
1-240-120	2400	1200	1250	180

TBDA	B	D	H	L	kg
1-160-080	1800	1600	800	650	72
1-180-100	2000	1800	1000	1250	115

Complements and Accessories

Duct accessories, uninsulated

TBLA Air heater for hot water

The TBLA air heater uses hot water for post-heating the supply air

The GOLD air handling unit's control system and its efficient rotary heat exchanger make it often possible design ventilation systems without downstream air heaters according to the ERS model if the air handling unit is operated in the temperature control mode.

Air heaters for the GOLD, size 004-040 can be installed for horizontal or vertical airflow, other sizes only for horizontal airflow.

The TBLA air heater, capacity variant 1, is available with Thermo Guard anti-frost tension protection for the size 004-040 GOLD units.

Technical data

Uninsulated casing made of galvanized sheet steel.

Finned-tube heat exchangers fabricated of copper tubes and profiled aluminium fins. The headers and the pipe-work to the water connections are made of copper. The male threaded pipe connections are made of brass.

The TBLA air heater for hot water is available in three capacity variants. Capacity variant 1 provides the lowest capacity and capacity variant 3 provides the highest capacity.

All the coils are equipped with individual plugs for venting and drainage. A separate connection is provided for an anti-frost monitor sensor.

Valve set

The TBVL valve set with 2(3)-way valve, actuator, freeze protection sensor and connection cable with quick connector can be ordered.

If you install a valve of your own, you can instead select a set of electrical connection components. This set contains the connection cable with quick connector, resistor and insertion-type or strap-on sensor.

Extra accessories

Circulation pump used for protecting the freeze protection monitor function if air heaters without anti-frost bursting protection are used.

Supplied with T coupling, non-return valve and adjustment valve. The automatic pump control system is built into the control equipment of the GOLD unit.

Installation

Provision for inspection and cleaning must be guaranteed. Electrical connection.



Installation principle with Thermo Guard

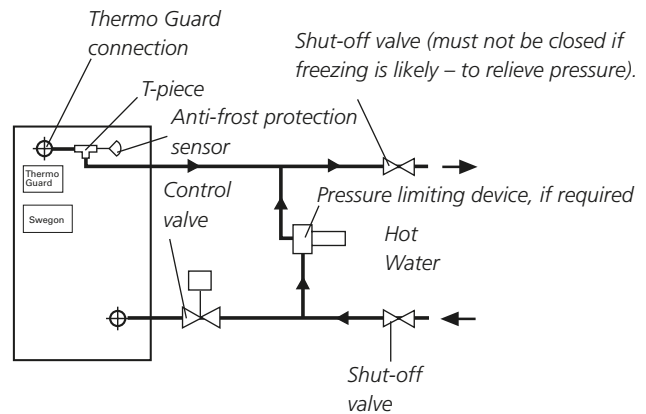

Installation principle without Thermo Guard

Applicable to TBLA 000-031, 000-040, 000-050, 060-030 and 080-040

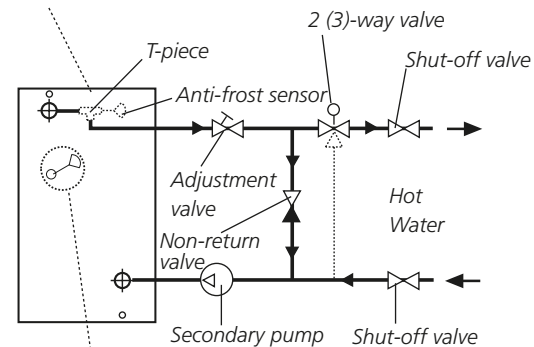

Anti-frost monitor sensor. Applicable to TBLA 100-040 to 240-120

1) The anti-frost sensor for the TBLA sizes 000-031, 000-040, 000-050, 060-030 and 000-050 should be fitted to the return pipework and for the TBLA sizes 100-040 and 240-120 in the connection on the coil.

Complements and Accessories

Duct accessories, uninsulated

Without Thermoguard

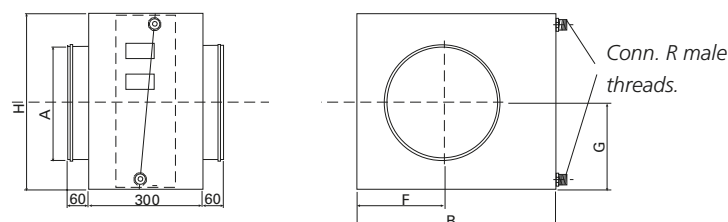

GOLD with standard end connection frame:
 TBLA 000-031, is compatible with GOLD sizes 004, 005
 TBLA 000-040, is compatible with GOLD size 007, 008
 TBLA 000-050, is compatible with GOLD size 011, 012

TBLA	A	B	F	G	H	R	kg*
5-000-031-2-1	Ø 315	490	225	192	405	DN15	17
7-000-040-2-1	Ø 400	590	277	250	500	DN20	16
5-000-040-2-2	Ø 400	590	277	250	500	DN20	18
5-000-050-2-1	Ø 500	690	327	300	600	DN20	21
7-000-050-2-2	Ø 500	690	327	300	600	DN20	22

* Excluding water.

With Thermoguard

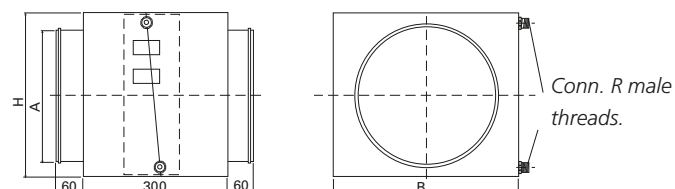

GOLD with standard end connection frame:
 TBLA 000-031, is compatible with GOLD sizes 004, 005
 TBLA 000-040, is compatible with GOLD size 007, 008
 TBLA 000-050, is compatible with GOLD size 011, 012

TBLA	A	B	H	R	kg*
4-000-031-1-1	Ø 315	488	428	DN 15	14
4-000-040-1-1	Ø 400	588	528	DN 15	19
4-000-050-1-1	Ø 500	688	628	DN 15	24

* Excluding water.

Complements and Accessories

Duct accessories, uninsulated

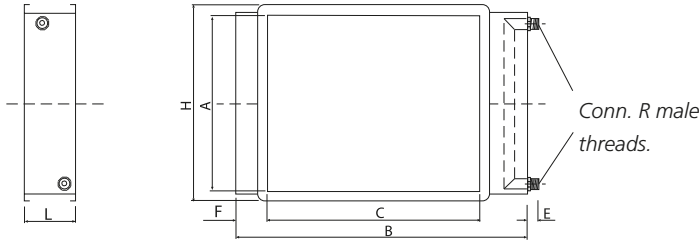

GOLD with standard end connection frame:
 TBLA 100-040, matches GOLD, sizes 014, 020
 TBLA 120-050, matches GOLD, sizes 025, 030
 TBLA 140-060, matches GOLD, sizes 035, 040

GOLD with full face connection frame (accessory TBXZ):
 TBLA-1-060-030, matches GOLD sizes 004, 005
 TBLA-1-080-040, matches GOLD sizes 007, 008
 TBLA-1-100-040, matches GOLD sizes 011, 012
 TBLA-1-120-050, matches GOLD sizes 014, 020
 TBLA-1-140-060, matches GOLD sizes 025, 030

Without Thermoguard

TBLA	A	B	C	E	H	L	R	F	kg*
4-060-030-2-1	300	728	600	80	338	148	DN15	47	6
4-060-030-2-2	300	728	600	80	338	148	DN15	47	7
4-080-040-2-1	400	928	800	80	438	148	DN15	47	8
4-080-040-2-2	400	928	800	80	438	148	DN15	47	10
5-100-040-2-1	400	1119	1000	90	438	148	DN15	40	14
5-100-040-2-2	400	1126	1000	90	438	170	DN20	40	18
5-120-050-2-1	500	1319	1200	90	538	148	DN15	40	17
5-140-060-2-1	600	1526	1400	90	638	148	DN20	40	23

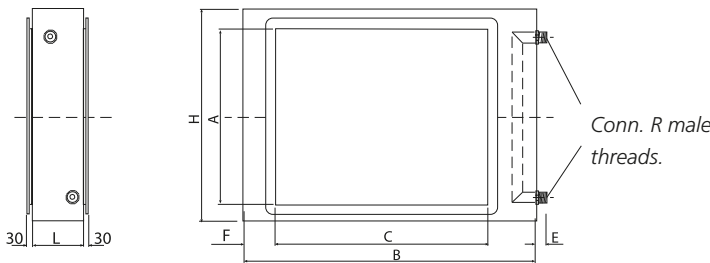

GOLD with standard end connection frame:
 TBLA 100-040, matches GOLD, sizes 014, 020
 TBLA 120-050, matches GOLD, sizes 025, 030
 TBLA 140-060, matches GOLD, sizes 035, 040
 TBLA 160-080, matches GOLD, sizes 050, 060
 TBLA 180-100, matches GOLD, sizes 070, 080
 TBLA 240-120, matches GOLD, sizes 100, 120

GOLD with full face connection frame (accessory TBXZ):
 TBLA 100-040, matches GOLD, sizes 011, 012
 TBLA 120-050, matches GOLD, sizes 014, 020
 TBLA 140-060, matches GOLD, sizes 025, 030
 TBLA 160-080, matches GOLD, sizes 035, 040
 TBLA 180-100, matches GOLD, sizes 050, 060
 TBLA 240-120, matches GOLD, sizes 070, 080

Without Thermoguard

TBLA	A	B	C	E	H	L	R	F	kg*
5-100-040-2-3	400	1250	1000	85	605	300	DN25	125	53
5-120-050-2-2	500	1590	1200	85	700	300	DN20	195	72
5-120-050-2-3	500	1590	1200	85	755	300	DN32	195	78
5-140-060-2-2	600	1815	1400	85	840	300	DN25	208	94
4-140-060-2-3	600	1850	1400	85	880	300	DN32	225	101
4-160-080-2-1	800	2210	1600	85	1020	300	DN25	280	97
4-160-080-2-2	800	2210	1600	85	1020	300	DN32	274	114
4-160-080-2-3	800	2210	1600	85	1020	300	DN50	259	127
4-180-100-2-1	1000	2530	1800	85	1220	300	DN25	340	127
4-180-100-2-2	1000	2530	1800	85	1220	300	DN32	329	152
4-180-100-2-3	1000	2530	1800	85	1220	300	DN50	319	168
4-240-120-2-1	1200	3240	2400	85	1520	300	DN40	389	187
4-240-120-2-2	1200	3240	2400	85	1520	300	DN50	374	235
4-240-120-2-3	1200	3240	2400	85	1520	300	DN65	358	264

* Excluding water.

Complements and Accessories

Duct accessories, uninsulated

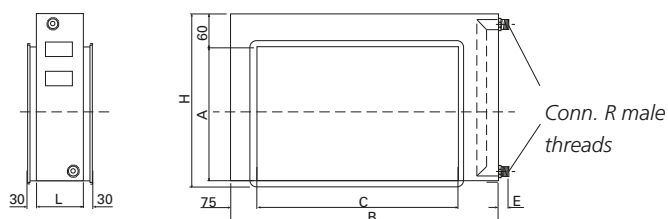

GOLD with full face connection frame (accessory TBXZ):
 TBLA 060-030, matches GOLD sizes 004, 005
 TBLA 080-040, matches GOLD sizes 007, 008

TBLA	Capacity variant 1							
	B	H	L	A	C	E	R	kg*
4-060-030-1-1	789	381	180	300	600	125	DN15	13
4-080-040-1-1	989	481	180	400	800	125	DN15	18

* Excluding water.

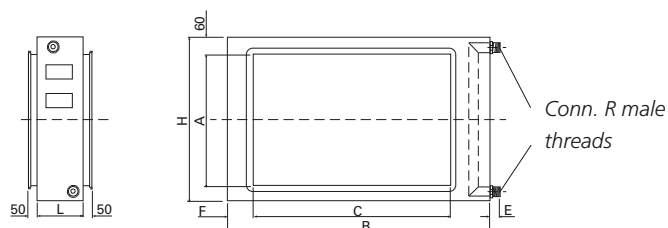

GOLD with standard end connection frame:
 TBLA 100-040, matches GOLD, sizes 014, 020
 TBLA 120-050, matches GOLD, sizes 025, 030
 TBLA 140-060, matches GOLD, sizes 035, 040
 TBLA 160-080, matches GOLD, sizes 050, 060
 TBLA 180-100, matches GOLD, sizes 070, 080
 TBLA 240-120, matches GOLD, sizes 100, 120

With Thermoguard

TBLA	Capacity variant 1								
	B	H	L	A	C	E	F	R	kg*
4-100-040	1213	580	210	400	1000	100	100	DN15	50
4-120-050	1568	680	210	500	1200	100	100	DN20	68
4-140-060	1818	820	210	600	1400	100	100	DN20	90
4-160-080	2173	1020	300	800	1600	100	254	DN25	121
4-180-100	2493	1195	300	1000	1800	100	310	DN32	159
4-240-120	3154	1510	300	1200	2400	100	356	DN50	195

* Excluding water.

GOLD with full face connection frame (accessory TBXZ):
 TBLA 100-040, matches GOLD, sizes 011, 012
 TBLA 120-050, matches GOLD, sizes 014, 020
 TBLA 140-060, matches GOLD, sizes 025, 030
 TBLA 160-080, matches GOLD, sizes 035, 040
 TBLA 180-100, matches GOLD, sizes 050, 060
 TBLA 240-120, matches GOLD, sizes 070, 080

Complements and Accessories

Duct accessories, uninsulated

TBLF Air heater for preheating, hot water

The TBLF air heater is used for preheating the supply air and uses hot water as the heating medium. The TBLF is installed in the outdoor air duct.

Reheating the air when the outdoor air is cold and the humidity is high can prevent condensate from forming in the filters. The function can also be used when it is extremely cold outdoors and you want to heat the air up to -20°C for instance.

Used in combination with a plate heat exchanger, it may be of interest to preheat the air in order to avoid having to by-pass the heat exchanger.

Technical data

The air heater is sized for heating from -4°C to + 4°C using 82/71°C heating water.

Uninsulated casing made of galvanized sheet steel.

Finned-tube heat exchangers fabricated of copper tubes and profiled aluminium fins. Fin pitch: 5.5 mm. The headers and the pipework connected to the water connections are made of copper.

The pipe connections have male threads and are made of brass.

Valve set

The TBVL valve set with 2(3)-way valve, valve actuator, freeze protection sensor and connection cable with quick-fit connector can be ordered. If you use a valve of your own, you can instead select a set of electrical connection components. This set contains a connection cable with quick-fit connector, resistor and insertion type or strap-on sensor.

GOLD with standard end connection frame:
 TBLF 000-031, matches GOLD, sizes 004, 005
 TBLF 000-040, matches GOLD, sizes 007, 008
 TBLF 000-050, matches GOLD, sizes 011, 012

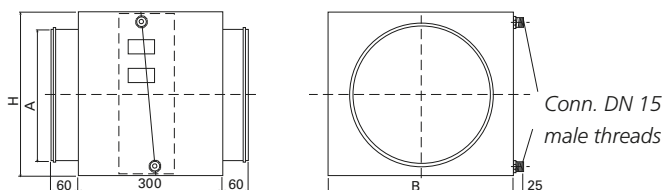

TBLF	A	B	H	kg*
1-000-031	∅ 315	488	405	12
1-000-040	∅ 400	588	528	16
1-000-050	∅ 500	688	628	19

* Excluding water.



Extra accessories

Control system including temperature sensor for installation in a duct and the IQlogic+ with a 0.25 metre long cable, with or without freeze protection sensor.

Circulation pump used for protecting the anti-frost monitor function if coils without anti-frost bursting protection are used. Supplied with T coupling, non-return valve and adjustment valve. The automatic pump control system is built into the control equipment of the GOLD unit.

Installation

Provision for inspection and cleaning must be guaranteed. Electrical connections.

GOLD with standard end connection frame:
 TBLF 100-040, matches GOLD, sizes 014, 020
 TBLF 120-050, matches GOLD, sizes 025, 030
 TBLF 140-060, matches GOLD, sizes 035, 040
 TBLF 160-080, matches GOLD, sizes 050, 060
 TBLF 180-100, matches GOLD, sizes 070, 080
 TBLF 240-120, matches GOLD sizes 100, 120

GOLD with full face connection frame (accessory TBXZ):
 TBLF 060-030, matches GOLD sizes 004, 005
 TBLF 080-040, matches GOLD sizes 007, 008
 TBLF 100-040, matches GOLD, sizes 011, 012
 TBLF 120-050, matches GOLD, sizes 014, 020
 TBLF 140-060, matches GOLD, sizes 025, 030
 TBLF 160-080, matches GOLD, sizes 035, 040
 TBLF 180-100, matches GOLD, sizes 050, 060
 TBLF 240-120, matches GOLD sizes 070, 080

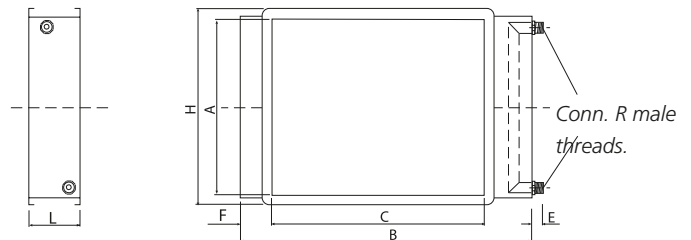

TBLF	A	B	C	E	H	L	R	F	kg*
1-060-030	300	728	600	80	338	148	DN15	47	5
1-080-040	400	935	800	80	438	148	DN20	47	7
1-100-040	400	1135	1000	100	438	148	DN20	47	13
1-120-050	500	1335	1200	100	538	148	DN20	47	16
1-140-060	600	1545	1400	100	638	148	DN25	47	20
1-160-080	800	1757	1600	100	838	148	DN32	47	27
1-180-100	1000	1957	1800	100	1038	148	DN32	47	31
1-240-120	1190	2568	2400	80	1238	148	DN32	47	43

* Excluding water.

Complements and accessories

Duct accessories, uninsulated

Air heater TBCE/TBRE, electric

Air heater TBCE/TBRE is used for reheating of the supply air or for certain preheating needs of outdoor air.

In many applications it is possible to omit the air heater for reheat if the air handling unit control system is operated in the temperature regulation mode according to the ERS model and when the efficient rotary heat exchanger is in use.

The air heater can be installed for horizontal or vertical airflow.

The integrated thyristor is controlled via signals from the GOLD air handling unit. The four, five or six series-coupled overheating protections and control signals are connected by means of a quick connector to the GOLD air handling unit.

Technical data

Uninsulated casing made of galvanized sheet steel.

Air heater TBCE/TBRE is available in several capacity variants.

The electrical equipment conforms to the provisions of Degree of Protection IP44.

The air heater is approved for operating temperatures, in the surroundings and the air stream, from -25°C to +40°C.

Installation

TBCE 000-031, 000-040 and 000-050: The end panel on the connection side can be dismantled for inspection and connection.

For air heaters with circular duct connection, the distance from or to a duct bend, damper, filter or the like, should be at least the distance that is equivalent to double (triple recommended) the diameter of the duct. For air heaters with a rectangular duct connection the distance should be at least the equivalent to the air heater's diagonal dimension (double recommended), i.e. from corner to corner in the duct section of the air heater. Otherwise there is risk that the airflow through the air heater will be non-uniform, involving risk that the overheat protection device will trip.

Electrical connection. **Power must be supplied directly from the electrical distribution box. An isolating switch is recommended.**



TBCE



TBRE

Complements and accessories

Duct accessories, uninsulated

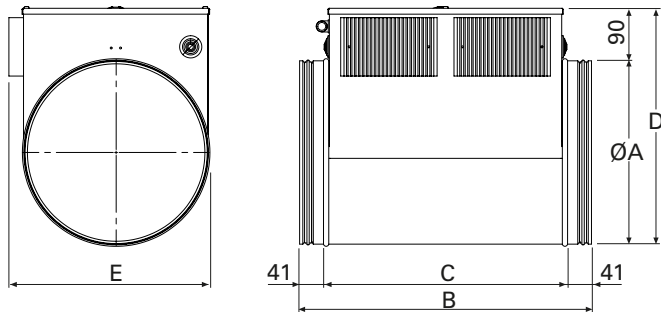

GOLD with standard end connection frame:
 TBCE 000-031, corresponds to GOLD sizes 004, 005
 TBCE-000-040, corresponds to GOLD sizes 007, 008
 TBCE-000-050, corresponds to GOLD sizes 011, 12

TBCE	ø A	B	C	D	E	kg
-1-000-031-002-2	315	375	293	405	344	8
-1-000-031-004-1	315	375	293	405	344	9
-1-000-031-004-2	315	375	293	405	344	9
-1-000-031-007-1	315	500	418	405	344	10,5
-1-000-031-007-2	315	500	418	405	344	10,5
-1-000-031-010-1	315	500	418	405	344	11,5
-1-000-031-010-2	315	500	418	405	344	11,5
-1-000-040-004-1	400	375	293	490	428	10,5
-1-000-040-004-2	400	375	293	490	428	10,5
-1-000-040-007-1	400	500	418	490	428	12,5
-1-000-040-007-2	400	500	418	490	428	12,5
-1-000-040-012-1	400	630	548	490	428	15
-1-000-040-012-2	400	630	548	490	428	15
-1-000-040-018-1	400	770	688	490	428	19,5
-1-000-040-018-2	400	770	688	490	428	20,5
-1-000-050-006-1	500	375	293	590	528	12,5
-1-000-050-006-2	500	375	293	590	528	12,5
-1-000-050-012-1	500	630	548	590	528	17,5
-1-000-050-012-2	500	630	548	590	528	17,5
-1-000-050-021-1	500	880	798	590	528	26
-1-000-050-021-2	500	880	798	590	528	26,5
-1-000-050-027-1	500	1150	1068	590	528	34
-1-000-050-027-2	500	1150	1068	590	528	34

Complements and accessories

Duct accessories, uninsulated

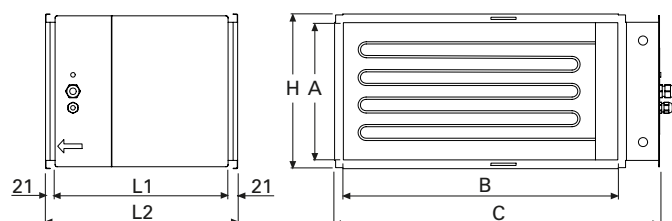

GOLD with standard end connection frame:

TBRE 100-040, corresponds to GOLD sizes 014, 020

TBRE 120-050, corresponds to GOLD sizes 025, 030

TBRE 140-060, corresponds to GOLD sizes 035, 040

TBRE 160-080, corresponds to GOLD sizes 050, 060

TBRE 180-100, corresponds to GOLD sizes 070, 080

TBRE 240-120, corresponds to GOLD sizes 100, 120

GOLD with full face end connection panel (accessory TBXZ):

TBRE 060-030, corresponds to GOLD sizes 004, 005

TBRE 080-040, corresponds to GOLD sizes 007, 008

TBRE 100-040, corresponds to GOLD, size 011, 012

TBRE 120-050 corresponds to GOLD sizes 014, 020

TBRE 140-060 corresponds to GOLD, size 025/30

TBRE 160-080 corresponds to GOLD, size 035/040

TBRE 180-100 corresponds to GOLD, size 050/060

TBRE 240-120 corresponds to GOLD, size 070/080

TBRE	A	B	C	H	L1	L2	kg
1-060-030	300	600	710	338	378	420	15 - 18
1-080-040	400	800	880	438	378	420	19 - 25,5
1-100-040	400	1000	1084	438	378	420	22 - 37
1-120-050	500	1200	1285	538	378	420	25 - 42
2-120-050	500	1200	1285	538	478	520	44 - 47,5
1-140-060	600	1400	1482	638	378	420	32 - 48
2-140-060	600	1400	1482	638	478	520	49 - 53,5
1-160-080	800	1600	1737	838	378	420	39 - 64
2-160-080	800	1600	1737	838	478	520	61 - 70,5
1-180-100	1000	1800	2017	1038	378	420	56 - 85
2-180-100	1000	1800	2017	1038	478	520	84 - 93
1-240-120	1200	2400	2521	1238	378	420	69,5 - 105
2-240-120	1200	2400	2521	1238	558	600	106

Complements and Accessories

Duct accessories, uninsulated

TBKA Air cooler for chilled water

TBKC (direct expansion)

The TBKA/TBKC air cooler is used for cooling the supply air with chilled water or evaporative refrigerant as the cooling medium.

The TBKA/TBKC air cooler is available in several capacity variants that cover existing needs for each size of GOLD unit.

The air cooler must be installed for horizontal airflow.

Technical data

Sizes 004-040 have an uninsulated casing made of galvanized sheet steel.

The TBKA/TBKC air coolers consist of copper tubes and profiled aluminium fins. The TBKA has headers and water connections made of copper/brass, with male connection threads. The TBKC has headers and distributor tubes made of copper. The connections are designed for brazed joints.

Valve set

The TBVL valve set with 2(3)-way valve, actuator and connection cable with quick-fit connector can be ordered for air cooler water. Temperature sensor water for reading incoming or outgoing cooling medium temperatures as an option.

If you use a valve of your own, you can instead select a set of electrical connection components. This set contains a connection cable with quick-fit connector, resistor and insertion type or strap-on sensor.

Installation

TBKA/TBKC 000-031, 000-040 and 000-050: The end panel on the connection side can be dismantled for inspection and connection. TBKA/TBKC 060-030 to 240-120: Provision for inspection and cleaning must be guaranteed.

Connecting the drainage pipework.

Electrical connections.



Complements and Accessories

Duct accessories, uninsulated

GOLD with standard end connection frame:

TBKA 000-031, matches GOLD, sizes 004, 005

TBKA 000-040, matches GOLD, sizes 007, 008

TBKA 000-050, matches GOLD, sizes 011, 012

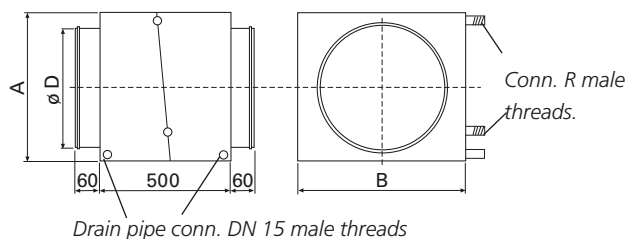

TBKA	A	B	D	R	kg*
5-000-031-1	430	490	315	DN15	37
5-000-031-2	430	490	315	DN20	39

* Excl. cooling medium

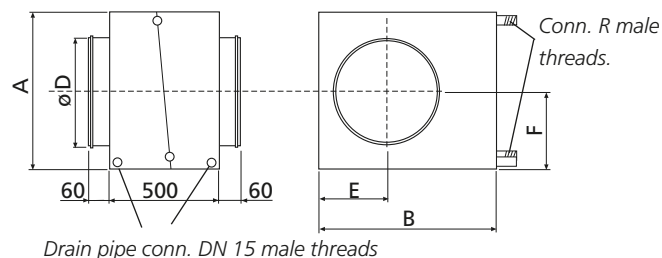

TBKA	A	B	D	E	F	R	kg*
5-000-040-1	475	590	400	255	238	DN20	36
5-000-040-2	475	590	400	255	238	DN20	38
5-000-050-1	575	690	500	295	288	DN25	50
5-000-050-2	575	690	500	295	288	DN25	54
4-000-050-5	755	770	500	358	378	DN25	44
4-000-050-6	755	770	500	358	378	DN32	52

* Excl. cooling medium

GOLD with standard end connection frame:

TBKC 000-031, matches GOLD, sizes 004, 005

TBKC 000-040, matches GOLD, sizes 007, 008

TBKC 000-050, matches GOLD, sizes 011, 012

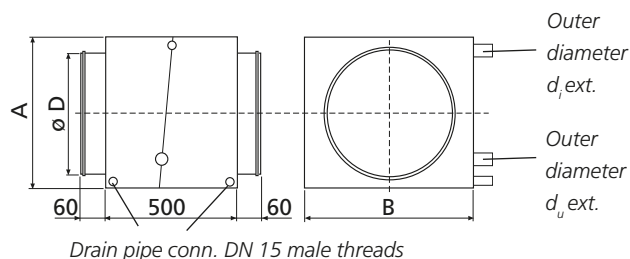

TBKC	A	B	D	d _i	d _u	kg*
4-000-031-1-1	430	490	315	12	12	37

* Excl. cooling medium

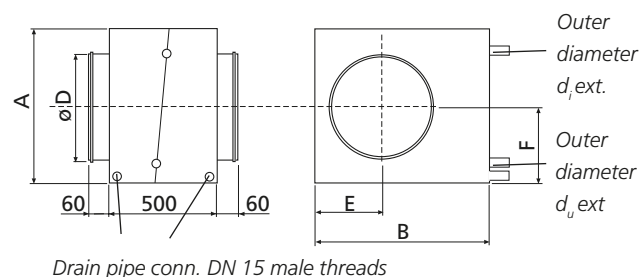

TBKC	A	B	D	E	F	d _i	d _u	kg*
3-000-040-1-1	455	590	400	255	228	12	22	28
4-000-050-1-1	575	690	500	295	288	22	22	50
3-000-050-3-1	755	770	500	358	378	22	42	46

* Excl. cooling medium

Complements and Accessories

Duct accessories, uninsulated

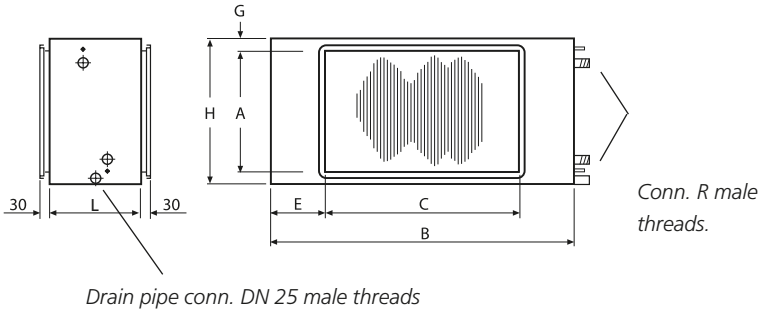

GOLD with standard end connection frame:
 TBKA 100-040, matches GOLD, sizes 014, 020
 TBKA 120-050, matches GOLD, sizes 025, 030
 TBKA 140-060, matches GOLD, sizes 035, 040
 TBKA 160-080, matches GOLD, sizes 050, 060
 TBKA 180-100, matches GOLD, sizes 070, 080
 TBKA 240-120, matches GOLD, sizes 100, 120

GOLD with full face connection frame (accessory TBXZ):
 TBKA 060-030, matches GOLD, sizes 004, 005
 TBKA 080-040, matches GOLD, sizes 007, 008
 TBKA 100-040, matches GOLD, sizes 011, 012
 TBKA 120-050, matches GOLD, sizes 014, 020
 TBKA 140-060, matches GOLD, sizes 025, 030
 TBKA 160-080, matches GOLD, sizes 035, 040
 TBKA 180-100, matches GOLD, sizes 050, 060
 TBKA 240-120, matches GOLD, sizes 070, 080

TBKA	A	B	C	E	G	H	L	R	kg*
5-060-030-1	300	754	600	47	19	361	240	DN15	13
5-060-030-2	300	754	600	47	19	361	240	DN20	15
5-060-030-3	300	754	600	47	19	361	300	DN20	17
5-080-040-1	400	954	800	47	19	461	240	DN20	19
5-080-040-2	400	954	800	47	19	461	240	DN25	22
5-080-040-3	400	954	800	47	19	461	300	DN25	26
5-100-040-0	400	1225	1000	77	64	527	500	DN32	52
5-100-040-1	400	1295	1000	148	113	625	500	DN32	58
5-100-040-2	400	1295	1000	148	113	625	500	DN32	60
5-100-040-3	400	1295	1000	148	113	625	500	DN32	64
5-120-040-4**	400	1495	1200	148	113	625	500	DN40	82
5-120-050-0	500	1425	1200	62	62	623	500	DN32	70
5-120-050-1	500	1595	1200	198	168	835	500	DN40	80
5-120-050-2	500	1595	1200	198	168	835	500	DN50	90
5-120-050-3	500	1595	1200	198	168	835	500	DN50	100
5-140-050-4**	500	1790	1400	195	168	835	500	DN50	122
5-140-060-0	600	1625	1400	62	62	723	500	DN32	91
5-140-060-1	600	1885	1400	243	170	940	500	DN50	106
5-140-060-2	600	1885	1400	243	170	940	500	DN50	118
5-140-060-3	600	1885	1400	243	170	940	500	DN65	134
5-160-060-4**	600	2085	1600	243	170	940	500	DN65	154
5-160-080-1	800	1794	1600	47	19	846	240	DN32	66
5-160-080-2	800	2180	1600	290	110	1020	500	DN50	174
5-160-080-3	800	2180	1600	290	110	1020	500	DN50	223
5-160-080-4	800	2180	1600	290	110	1020	500	DN65	211
5-180-100-1	1000	1994	1800	47	19	1051	240	DN50	88
5-180-100-2	1000	2500	1800	350	110	1220	500	DN65	232
5-180-100-3	1000	2500	1800	350	110	1220	500	DN65	228
5-180-100-4	1000	2500	1800	350	110	1220	500	DN65	250
5-240-120-1	1200	2644	2400	47	19	1256	240	DN65	138
5-240-120-2	1200	3210	2400	405	160	1520	500	DN65	309
5-240-120-3	1200	3210	2400	405	160	1520	500	DN80	406
5-240-120-4	1200	3210	2400	405	160	1520	500	DN100	454

* Excl. cooling agent

** The connection dimensions of the air cooler are not the same as those of the GOLD unit.
 Some form of transition piece must be installed between the air handling unit and the air cooler.

Complements and accessories

Duct accessories, uninsulated

Capacity variant 0

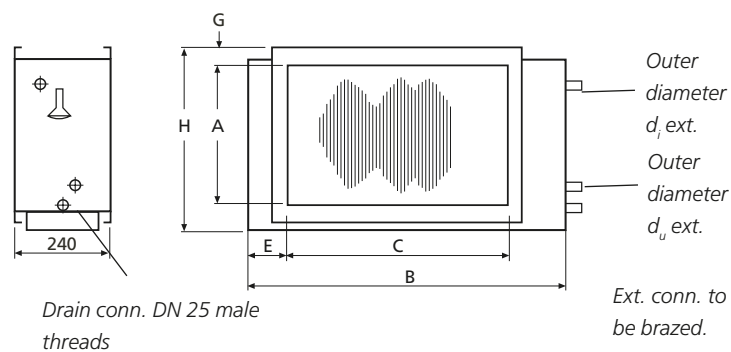

GOLD with standard end connection frame:
 TBKC 100-040, matches GOLD, sizes 014, 020
 TBKC 120-050, matches GOLD, sizes 025, 030
 TBKC 140-060, matches GOLD, sizes 035, 040

GOLD with full face connection frame (accessory TBXZ):
 TBKC 100-040, matches GOLD, sizes 011, 012
 TBKC 120-050, matches GOLD, sizes 014, 020
 TBKC 140-060, matches GOLD, sizes 025, 030

TBKC	A	B	C	E	G	H	d_i	d_u	kg*
3-100-040-0-1	400	1154	1000	49	19	461	22	28	24
3-100-040-0-2	400	1154	1000	49	19	461	12/16	16/22	25
3-120-050-0-1	500	1394	1200	49	19	561	28	35	33
3-120-050-0-2	500	1394	1200	49	19	561	16/28	22/35	34
3-140-060-0-1	600	1594	1400	49	19	661	28	35	41
3-140-060-0-2	600	1594	1400	49	19	661	22/28	28/35	42

* Excl. cooling agent

Complements and Accessories

Duct accessories, uninsulated

Capacity variants 1 – 3

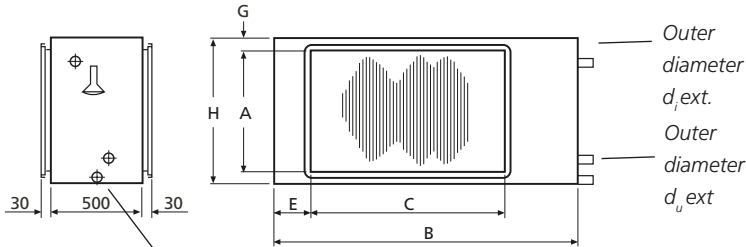

Drain pipe conn. DN 25 male thread

Ext. conn. to be brazed.

GOLD with standard end connection frame:
 TBKC 100-040, matches GOLD, sizes 014, 020
 TBKC 120-050, matches GOLD, sizes 025, 030
 TBKC 140-060, matches GOLD, sizes 035, 040
 TBKC 160-080, matches GOLD, sizes 050, 060
 TBKC 180-100, matches GOLD, sizes 070, 080
 TBKC 240-120, matches GOLD, sizes 100, 120

GOLD with full face connection frame (accessory TBXZ):
 TBKA 060-030, matches GOLD, sizes 004, 005
 TBKA 080-040, matches GOLD, sizes 007, 008
 TBKC 100-040, matches GOLD, sizes 011, 012
 TBKC 120-050, matches GOLD, sizes 014, 020
 TBKC 140-060, matches GOLD, sizes 025, 030
 TBKC 160-080, matches GOLD, sizes 035, 040
 TBKC 180-100, matches GOLD, sizes 050, 060
 TBKC 240-120, matches GOLD, sizes 070, 080

TBKC	A	B	C	E	G	H	d _i	d _u	kg*
3-060-030-1-1	300	880	600	62	50	401	12	19	10
3-060-030-2-1	300	880	600	62	50	401	22	22	11
3-060-030-3-1	300	880	600	62	50	401	22	28	13
3-080-040-1-1	400	1080	800	62	50	501	22	22	15
3-080-040-2-1	400	1080	800	62	50	501	22	28	17
3-080-040-3-1	400	1080	800	62	50	501	28	28	20
3-100-040-1-1	400	1350	1000	175	112,5	650	28	35	81
3-100-040-1-2	400	1350	1000	175	112,5	650	16/22	22/28	84
3-100-040-2-1	400	1350	1000	175	112,5	650	28	35	86
3-100-040-2-2	400	1350	1000	175	112,5	650	16/22	22/28	89
3-120-050-1-1	500	1590	1200	195	170	840	28	35	108
3-120-050-1-2	500	1590	1200	195	170	840	16/28	22/35	112
3-120-050-2-1	500	1590	1200	195	170	840	35	42	116
3-120-050-2-2	500	1590	1200	195	170	840	22/28	28/35	121
3-120-050-3-1	500	1590	1200	195	170	840	35	42	123
3-120-050-3-2	500	1590	1200	195	170	840	22/35	28/42	128
3-140-060-1-1	600	1950	1400	275	175	950	35	42	147
3-140-060-1-2	600	1950	1400	275	175	950	22/28	28/35	152
3-140-060-2-1	600	1950	1400	275	175	950	35	42	156
3-140-060-2-2	600	1950	1400	275	175	950	22/28	28/35	161
3-140-060-3-1	600	1950	1400	275	175	950	42	54	169
3-140-060-3-2	600	1950	1400	275	175	950	28/35	35/42	175
3-160-080-1-1	800	1794	1600	47	19	861	35	42	55
3-160-080-1-2	800	1794	1600	47	19	861	22/28	28/35	56
3-160-080-2-1	800	2210	1600	305	110	1020	42	54	181
3-160-080-2-2	800	2210	1600	305	110	1020	28/35	35/42	182
3-160-080-3-1	800	2210	1600	305	110	1020	35	54	199
3-160-080-3-2	800	2210	1600	305	110	1020	22/28	35/42	200
3-180-100-1-1	1000	1994	1800	47	19	1061	42	54	80
3-180-100-1-2	1000	1994	1800	47	19	1061	28/35	35/42	81
3-180-100-2-1	1000	2530	1800	365	110	1220	54	76	237
3-180-100-2-2	1000	2530	1800	365	110	1220	28/42	35/54	238
3-180-100-3-1	1000	2530	1800	365	110	1220	42	76	254
3-180-100-3-2	1000	2530	1800	365	110	1220	28/35	42/54	255
3-240-120-1-1	1200	2594	2400	47	19	1261	42	54	121
3-240-120-1-2	1200	2594	2400	47	19	1261	28/35	35/42	122
3-240-120-2-1	1200	3240	2400	420	160	1520	42	76	383
3-240-120-2-2	1200	3240	2400	420	160	1520	28/35	42/54	384
3-240-120-3-1	1200	3240	2400	420	160	1520	42	76	413
3-240-120-3-2	1200	3240	2400	420	160	1520	28/35	42/54	415

* Excl. cooling agent

Complements and Accessories

Duct accessories

TBBD Mixing Section

The TBBD mixing section is available for the GOLD SD in sizes 004-080.

The mixing section can be used when it is desirable use recirculated air for completely or partially heating a building while it is unoccupied.

The TBBD consists of a spiral tubular T-piece (sizes 000-031 – 000-050) or a rectangular duct with three connections for slip-clamp jointing (sizes 060-030 – 180-100).

The spiral duct joints (sizes 000-031 – 000-050) in required quantity and the sets of slip clamps (sizes 060-030 – 180-100) respectively are included in the supply.

The dampers are always supplied with mounted damper actuator. These have modulated action.

The mixing section can be ordered with two or three dampers depending on its range of application. See the example on the next page.

Additional equipment required: Supply air units should be provided with a downstream electric air heater or air heater for hot water.

Work to be carried out at the building site: Install the mixing section securing it to the air handling unit/duct
Install dampers for the mixing section or duct
Wire electrical connections to the GOLD unit's control equipment (separate power supply is not required)
Install insulation conforming to local regulations



Complements and Accessories

Duct accessories, uninsulated

Circular duct connections

Example 1, two dampers

The mixing section consists of two unmounted dampers, two joints and one spiral tubular T-piece. The connecting rod for the common damper motor is included in the supply.

Example 2, three dampers

As example 1 + one unmounted damper with its own damper motor, two joints and one spiral tubular T-piece.

Rectangular duct connections

Example 1, two dampers

The mixing section consists of two unmounted dampers and one rectangular duct with three connections for slip-clamp jointing. The connecting rod for the common damper motor is included in the supply of sizes 060-030 – 120-050. Dampers in sizes 140-060 – 180-100 each have their own damper motor. The mixing section can be installed for connection on the right-hand or left-hand side.

Example 2, three dampers

As example 1 + one unmounted damper with its own damper motor and one rectangular duct with three connections for slip-clamp jointing.

Example 1 (two dampers)

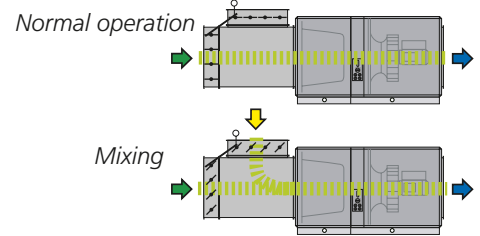

Example 2 (three dampers)

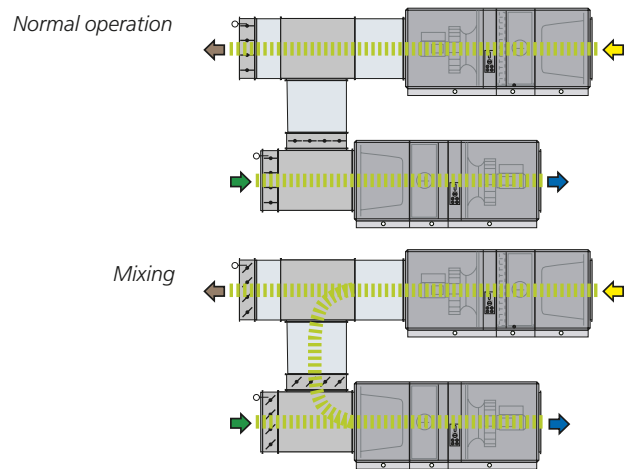

The items supplied from Swegon are shaded in grey.



Outdoor air Extract air Supply air Exhaust air

Complements and Accessories

Duct accessories, uninsulated

Two dampers

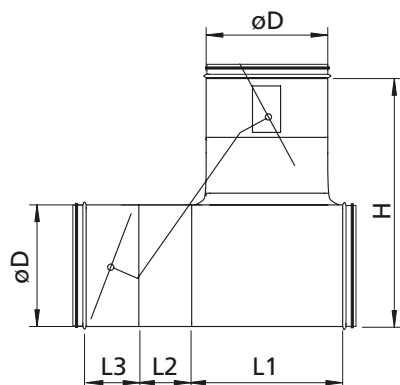

GOLD with standard end connection frame:
 TBBD 000-031, matches GOLD, size 004/005
 TBBD 000-040, matches GOLD, size 007/008
 TBBD 000-050, matches GOLD, size 011/012

TBBD	L1	L2	L3	H	øD
000-031	363	140	140	620	315
000-040	510	180	210	825	400
000-050	552	180	210	930	500

Three dampers

The dimensions of the component parts supplied by Swegon can be read in the sketch to the left.

Two dampers

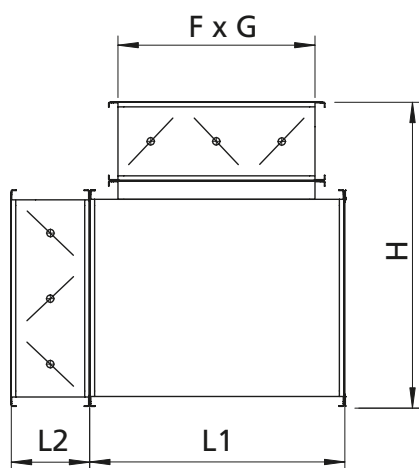

GOLD with standard end connection frame:
 TBBD 100-040, matches GOLD, size 014/020
 TBBD 120-050, matches GOLD, size 025/030
 TBBD 140-060, matches GOLD, size 035/040
 TBBD 160-080, matches GOLD, size 050/060
 TBBD 180-100, matches GOLD, size 070/080

GOLD with full face connection frame (accessory TBXZ):
 TBBD 060-030, matches GOLD, sizes 004, 005
 TBBD 080-040, matches GOLD, sizes 007, 008
 TBBD 100-040, matches GOLD, sizes 011, 012
 TBBD 120-050, matches GOLD, sizes 014, 020
 TBBD 140-060, matches GOLD, sizes 025, 030
 TBBD 160-080, matches GOLD, sizes 035, 040
 TBBD 180-100, matches GOLD, sizes 050, 060

TBBD	L1	L2	H	F x G
060-030	420	220	570	300 x 600
080-040	520	220	670	400 x 800
100-040	520	220	670	400 x 1000
120-050	620	220	770	500 x 1200
140-060	720	220	870	600 x 1400
160-080	920	220	1070	800 x 1600
180-100	1120	220	1270	1000 x 1800

Three dampers

The dimensions of the component parts supplied by Swegon can be read in the sketch to the left.

Complements and Accessories

Duct accessories, uninsulated

TBFA Prefilter

The prefilter should be installed in the outdoor air duct and/or the extract air duct.

The prefilter is used in ventilation systems in which the extract air and/or the outdoor air is heavily polluted and it is desirable to prevent the fine filter located in the GOLD unit from becoming clogged after a short period of use.

Technical data

The TBFA has an uninsulated casing made of galvanized sheet steel. Insulated Inspection door.

Filter of type woven aluminium filter or class G3 compact filter.

Extra accessories

The pressure sensor can be selected; alarm limit and current filter pressure can then be read in the hand-held micro terminal of the GOLD unit.

Installation

Provision for inspection and cleaning must be guaranteed. Install insulation conforming to local regulations.

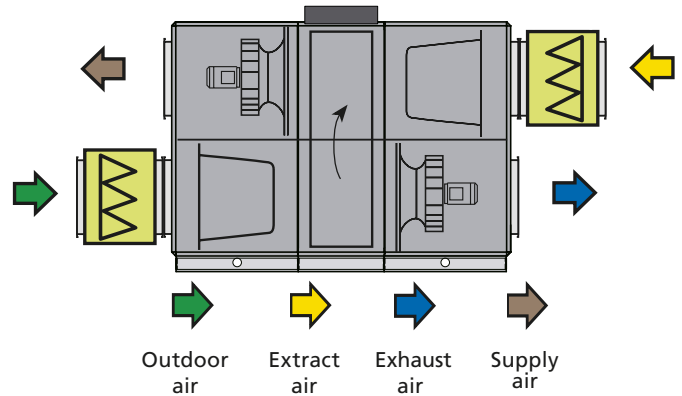

TBFA 000-031, is compatible with GOLD sizes 004, 005
 TBFA 000-040, is compatible with GOLD size 007, 008
 TBFA 000-050, is compatible with GOLD size 011, 012

TBFA 100-040, is compatible with GOLD sizes 014, 020
 TBFA 120-050, is compatible with GOLD sizes 025, 030
 TBFA 140-060, is compatible with GOLD sizes 035, 040
 TBFA 160-080, is compatible with GOLD sizes 050, 060
 TBFA 180-100, is compatible with GOLD sizes 070, 080
 TBFA 240-120, is compatible with GOLD sizes 070, 080

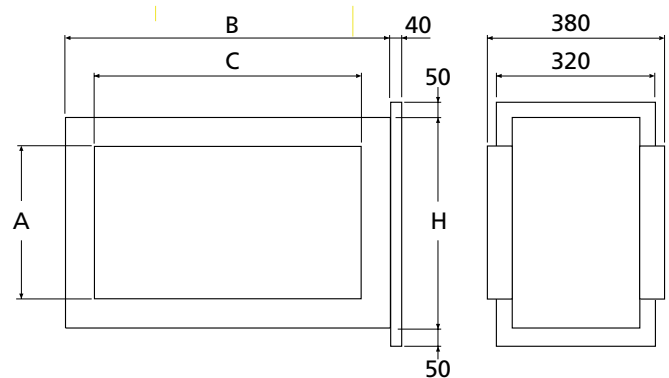
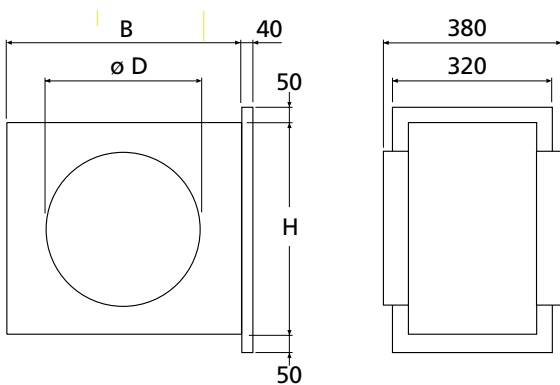

TBFA	B	D	H	kg
000-031	500	315	500	18
000-040	600	400	600	22
000-050	900	500	600	24

TBFA	A	B	C	H	kg
100-040	400	1200	1000	600	26
120-050	500	1500	1200	600	36
140-060	600	1800	1400	900	48
160-080	800	2475	1600	1000	59
180-100	1000	2400	1800	1200	68
240-120	1200	3000	2400	1800	140

Complements and Accessories

Duct accessories, in insulated casing

Common for duct accessories in an insulated casing

The duct accessories are to be positioned outside the GOLD unit. The unique Wing+ fans in the GOLD air handling unit also make it possible to connect duct accessories directly to the duct connection of the GOLD air handling unit without pressure losses or non-uniform air distribution.

Duct accessories in an insulated casing must be used if the unit is installed outdoors.

Duct accessories for the GOLD are equipped with bolt joints and/or expansion-type locking devices for docking them to the air handling unit and/or other duct accessories (does not apply to type TBFK carbon filter sections).

Type METU connection frames are available as an accessories for the size 014 – 120 units.

One duct accessory can be mounted on top of another duct accessory.

Other particulars for sizing can be computed in the AHU Design air handling unit selection program.



Complements and Accessories

Duct accessories, in insulated casing

TCSA Damper section

TCSA dampers are used as shut-off dampers or forced air-flow dampers. Sizes 012 - 120 can also be used for other applications, such as outdoor air dampers for the ReCO₂ control function.

Shut-off dampers are normally used if the air handling unit is idle during some period, for example at night, or if an air heater for hot water without anti-frost burst protection is used.

To be installed for horizontal airflow.

Complete with damper actuator for 24 V. The actuator can be selected with spring return or on/off actuation. TCSA sizes 012 - 120 are also available with modulating type actuator with spring return.

Technical data

Insulated casing. The outer skin is made of galvanized sheet steel, re-painted in Swegon's own grey metallic paint (closest comparable RAL colour: 9007). The inner skin is made of aluminium-zinc plated sheet steel. Environmental class C4.

Tightness class 3 to EN 1751.

Installation

The damper section should be mounted directly against the air handling unit or insulated duct accessory.

Wire the control and power supply cables to the appropriate wiring terminal on the air handling unit.



Complements and accessories

Duct accessories, in insulated casing

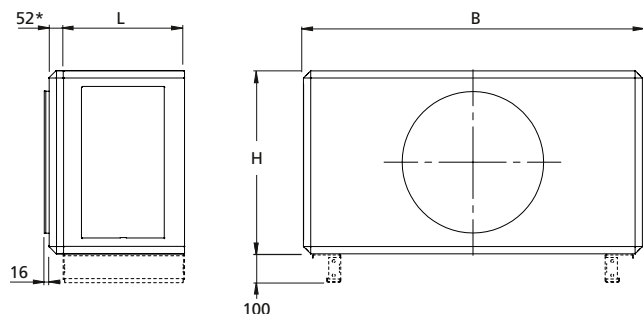

Connection dimensions to duct:
 TCSA 005 \varnothing 315
 TCSA 008 \varnothing 400

Base beam is optional on duct accessories in the lower duct. Duct accessories in the upper duct are always delivered without base beam.

* If several duct accessories are arranged in succession, the end connection panel is supplied only on the duct accessory farthest out facing the ductwork.

TCSA	B	H	L	kg	End connection panel, if required kg
-005	825	460	400	41	7
-008	995	542,5	400	47	10

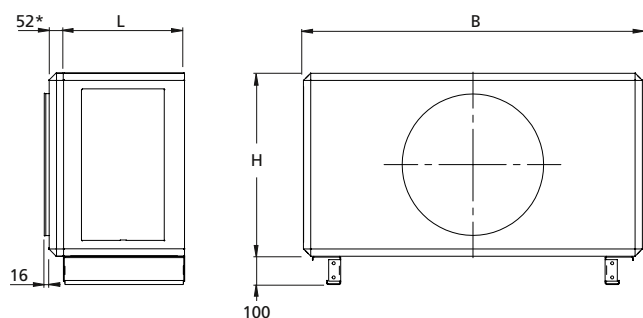

Connection dimensions to duct:
 TCSA 012 \varnothing 500

Duct accessories in the lower duct are always delivered with mounted base beam. Duct accessories in the upper duct are always delivered without base beam.

* If several duct accessories are arranged in succession, the end connection panel is supplied only on the duct accessory farthest out facing the ductwork.

TCSA	B	H	L	kg	End connection panel, if required kg
-012	1199	647,5	400	60	13

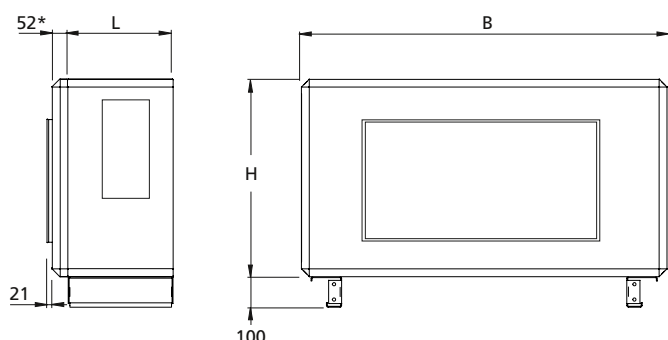

Connection dimensions to duct:
 TCSA 020 1000 x 400 mm
 TCSA 030 1200 x 500 mm
 TCSA 040 1400 x 600 mm
 TCSA 060 1600 x 800 mm

Duct accessories in the lower duct are always delivered with mounted base beam. Duct accessories in the upper duct are always delivered without base beam.

* If several duct accessories are arranged in succession, the end connection panel is supplied only on the duct accessory farthest out facing the ductwork.

TCSA	B	H	L	kg	End connection panel, if required kg
-020	1400	775,5	400	74	19
-030	1600	905,5	400	83	23
-040	1990	1079,5	400	102	34
-060	2318	1144	400	142	34

Complements and Accessories

Duct accessories, in insulated casing

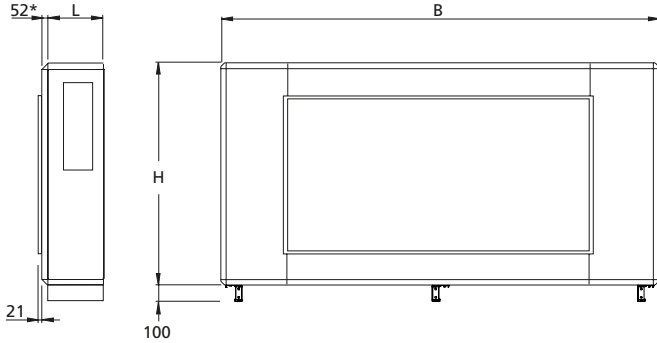

Connection dimensions to duct:
TCSA 080 1800 x 1000 mm

Duct accessories in the lower duct are always delivered with mounted base beam. Duct accessories in the upper duct are always delivered without base beam.

* If several duct accessories are arranged in succession, the end connection panel is supplied only on the duct accessory farthest out facing the ductwork.

TCSA	B	H	L	kg	End connection panel, if required kg
-080	2637	1320	400	192	40

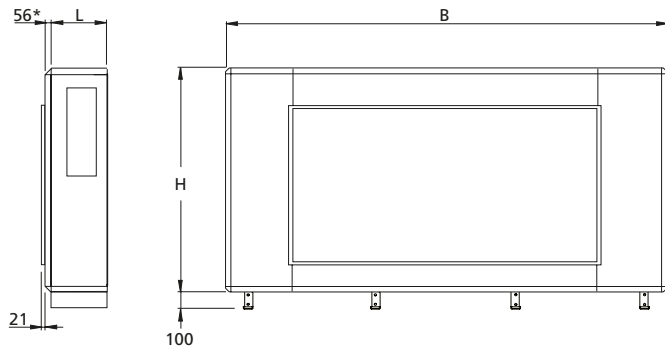

Connection dimensions to duct:
TCSA 120 2400 x 1200 mm

* If several duct accessories are arranged in succession, the end connection panel is supplied only on the duct accessory farthest out facing the ductwork.

TCSA	B	H	L	kg	End connection panel, if required kg
-120	3340	1620	500	337	59

Complements and Accessories

Duct accessories, in insulated casing

Spacer section, TCGA/ Inspection section, TCIA.

The TCGA spacer section/TCIA inspection section is used when provision for spacing or inspection is required.

The TCIA inspection section is available in two variants, with inspection door the entire length of the section (sizes 005-120), or split cover panel/inspection door (sizes 005-040).

The spacer section/inspection section must be installed for horizontal airflow.

Technical data

Insulated casing. The outer skin is made of galvanized sheet steel, re-painted in Swegon's own grey metallic paint (closest comparable RAL colour: 9007). The inner skin is made of aluminium-zinc plated sheet steel. Environmental Class C4.

Installation

The spacer section/inspection section should be fitted directly to the air handling unit or other insulated duct accessory.

Provision for inspection and cleaning the spacer section must be guaranteed. The cover panel is easy to remove.



Spacer Section, TCGA



TCIA inspection section. Inspection door the entire length of the section.



TCIA inspection section. Split cover panel/inspection door.

Spacer Section, TCGA

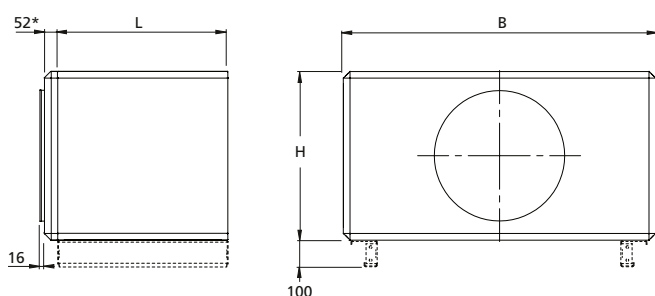

Connection dimensions to duct:

TCGA 005 \varnothing 315

TCGA 008 \varnothing 400

Base beam is optional on duct accessories in the lower duct. Duct accessories in the upper duct are always delivered without base beam.

* If several duct accessories are arranged in succession, the end connection panel is supplied only on the duct accessory farthest out facing the ductwork.

TCGA	B	H	L	kg	End connection panel, if required	
					kg	
-005	825	460	565	37	7	
-005	825	460	850	54	7	
-008	995	542,5	565	43	10	
-008	995	542,5	850	63	10	

Complements and accessories

Duct accessories, in insulated casing

Spacer Section, TCGA

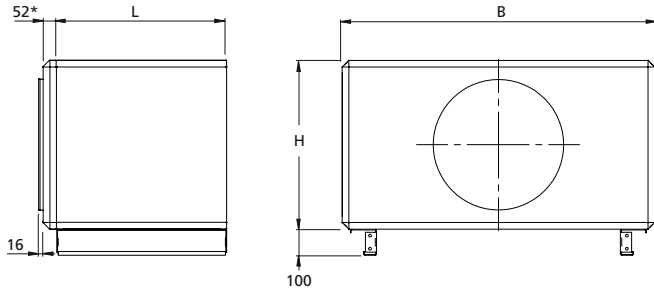

Connection dimensions to duct:
TCGA 012 $\varnothing 500$

Duct accessories in the lower duct are always delivered with mounted base beam. Duct accessories in the upper duct are always delivered without base beam.

* If several duct accessories are arranged in succession, the end connection panel is supplied only on the duct accessory farthest out facing the ductwork.

TCGA	B	H	L	kg	End connection panel, if required kg
-012	1199	647,5	565	52	13
-012	1199	647,5	850	74	13

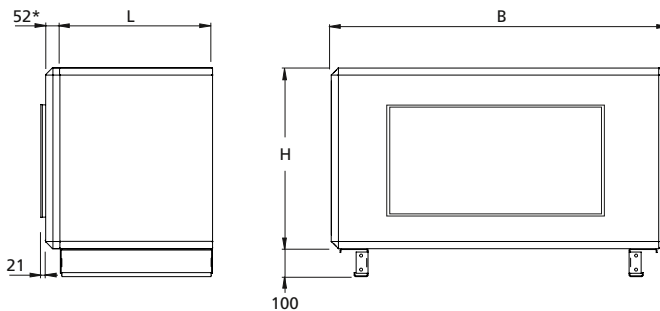

Connection dimensions to duct:
TCGA 020 1000 x 400 mm
TCGA 030 1200 x 500 mm
TCGA 040 1400 x 600 mm
TCGA 060 1600 x 800 mm

Duct accessories in the lower duct are always delivered with mounted base beam. Duct accessories in the upper duct are always delivered without base beam.

* If several duct accessories are arranged in succession, the end connection panel is supplied only on the duct accessory farthest out facing the ductwork.

TCGA	B	H	L	kg	End connection panel, if required kg
-020	1400	775,5	565	61	19
-020	1400	775,5	850	86	19
-030	1600	905,5	565	69	23
-030	1600	905,5	850	96	23
-040	1990	1079,5	565	78	34
-040	1990	1079,5	850	113	34
-060	2318	1144	565	110	34
-060	2318	1144	850	141	34

Complements and accessories

Duct accessories, in insulated casing

Spacer Section, TCGA

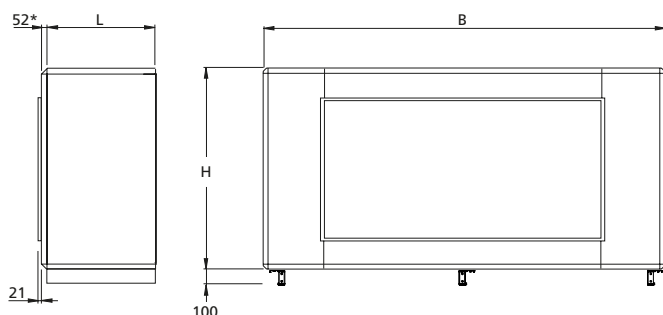

Connection dimensions to duct:
TCGA 080 1800 x 1000 mm

Duct accessories in the lower duct are always delivered with mounted base beam. Duct accessories in the upper duct are always delivered without base beam.

* If several duct accessories are arranged in succession, the end connection panel is supplied only on the duct accessory farthest out facing the ductwork.

TCGA	B	H	L	kg	End connection panel, if required kg
-080	2637	1320	565	129	40
-080	2637	1320	850	174	40

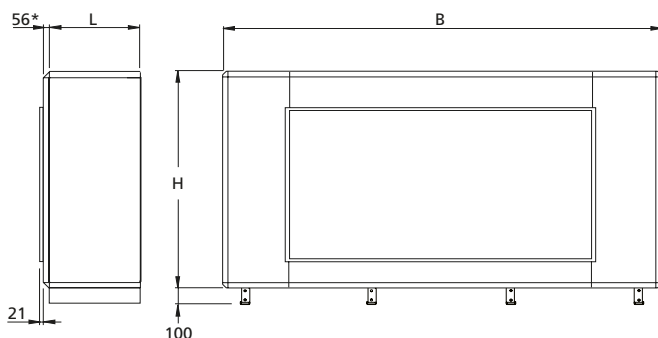

Connection dimensions to duct:
TCGA 120 2400 x 1200 mm

* If several duct accessories are arranged in succession, the end connection panel is supplied only on the duct accessory farthest out facing the ductwork.

TCGA	B	H	L	kg	End connection panel, if required kg
-120	3340	1620	720	244	59

Complements and accessories

Duct accessories, in insulated casing

The TCIA inspection section, inspection door in the entire length of the section

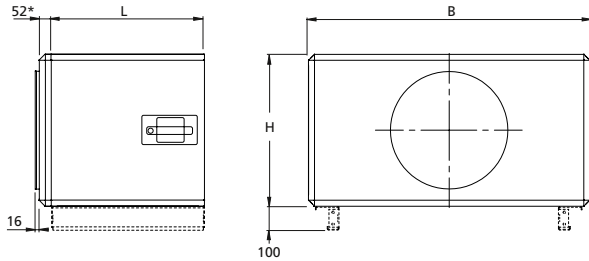

Connection dimensions to duct:
 TCIA 005 \varnothing 315
 TCIA 008 \varnothing 400

Base beam is optional on duct accessories in the lower duct. Duct accessories in the upper duct are always delivered without base beam.
 * If several duct accessories are arranged in succession, the end connection panel is supplied only on the duct accessory farthest out facing the ductwork.

TCIA	B	H	L	kg	End connection panel, if required kg
-005	825	460	565	37	7
-005	825	460	850	54	7
-008	995	542,5	565	43	10
-008	995	542,5	850	63	10

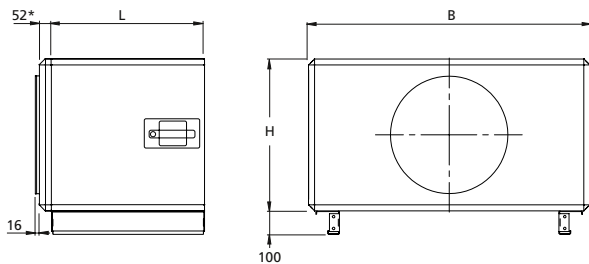

Connection dimensions to duct:
 TCIA 012 \varnothing 500

Duct accessories in the lower duct are always delivered with mounted base beam. Duct accessories in the upper duct are always delivered without base beam.
 * If several duct accessories are arranged in succession, the end connection panel is supplied only on the duct accessory farthest out facing the ductwork.

TCIA	B	H	L	kg	End connection panel, if required kg
-012	1199	647,5	565	52	13
-012	1199	647,5	850	74	13

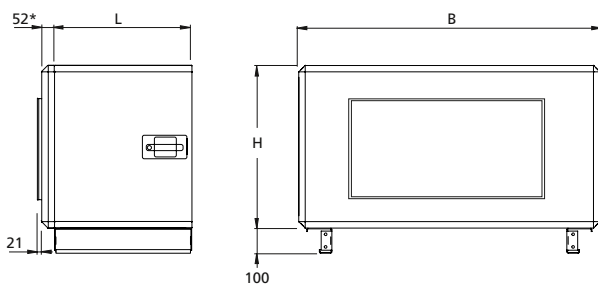

Connection dimensions to duct:
 TCIA 020 1000 x 400 mm
 TCIA 030 1200 x 500 mm
 TCIA 040 1400 x 600 mm
 TCIA 060 1600 x 800 mm

Duct accessories in the lower duct are always delivered with mounted base beam. Duct accessories in the upper duct are always delivered without base beam.
 * If several duct accessories are arranged in succession, the end connection panel is supplied only on the duct accessory farthest out facing the ductwork.

TCIA	B	H	L	kg	End connection panel, if required kg
-020	1400	775,5	565	61	19
-020	1400	775,5	850	86	19
-030	1600	905,5	565	69	23
-030	1600	905,5	850	96	23
-040	1990	1079,5	565	81	34
-040	1990	1079,5	850	117	34
-060	2318	1144	565	103	34
-060	2318	1144	850	143	34

Complements and accessories

Duct accessories, in insulated casing

The TCIA inspection section, inspection door in the entire length of the section

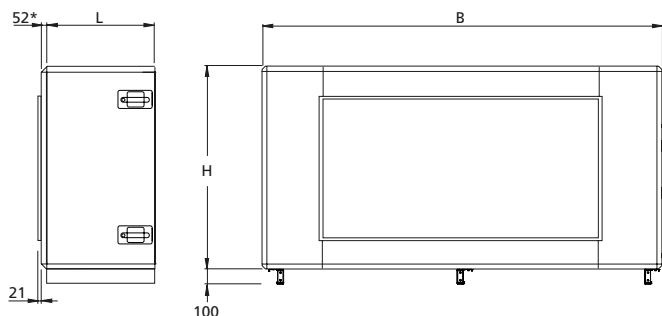

Connection dimensions to duct:
TCIA 080 1800 x 1000 mm

Duct accessories in the lower duct are always delivered with mounted base beam. Duct accessories in the upper duct are always delivered without base beam.

* If several duct accessories are arranged in succession, the end connection panel is supplied only on the duct accessory farthest out facing the ductwork.

TCIA	B	H	L	kg	End connection panel, if required kg
-080	2637	1320	565	129	40
-080	2637	1320	850	174	40

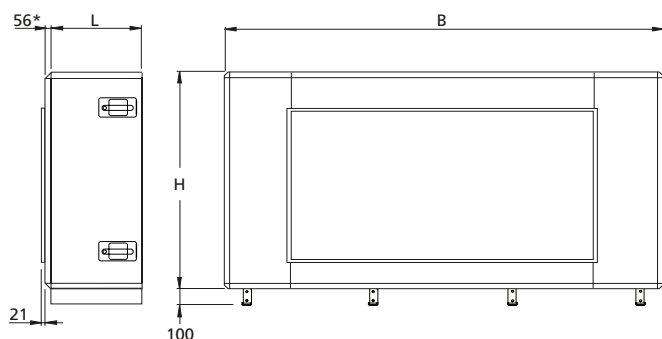

Connection dimensions to duct:
TCIA 120 2400 x 1200 mm

* If several duct accessories are arranged in succession, the end connection panel is supplied only on the duct accessory farthest out facing the ductwork.

TCIA	B	H	L	kg	End connection panel, if required kg
-120	3340	1620	500	200	59
-120	3340	1620	720	247	59

Complements and accessories

Duct accessories, in insulated casing

TCIA inspection section, split cover panel/inspection door

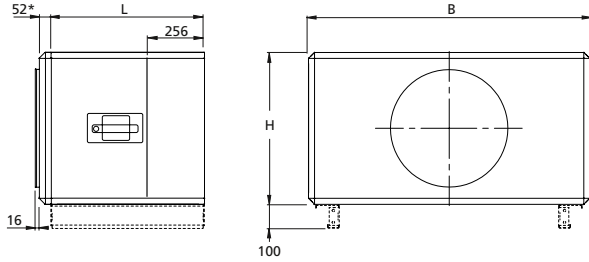

Connection dimensions to duct:
 TCIA 005 \varnothing 315
 TCIA 008 \varnothing 400

Base beam is optional on duct accessories in the lower duct. Duct accessories in the upper duct are always delivered without base beam.
 * If several duct accessories are arranged in succession, the end connection panel is supplied only on the duct accessory farthest out facing the ductwork.

TCIA	B	H	L	kg	End connection panel, if required kg
-005	825	460	850	54	7
-008	995	542,5	850	63	10

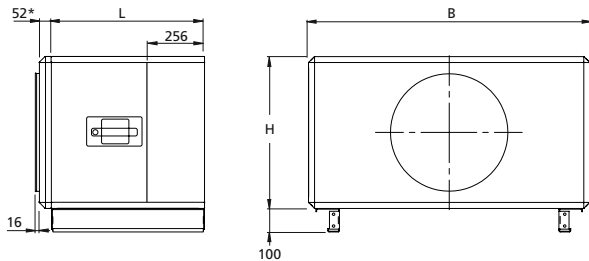

Connection dimensions to duct:
 TCIA 012 \varnothing 500

Duct accessories in the lower duct are always delivered with mounted base beam. Duct accessories in the upper duct are always delivered without base beam.
 * If several duct accessories are arranged in succession, the end connection panel is supplied only on the duct accessory farthest out facing the ductwork.

TCIA	B	H	L	kg	End connection panel, if required kg
-012	1199	647,5	850	74	13

Complements and accessories

Duct accessories, in insulated casing

TCIA inspection section, split cover panel/inspection door

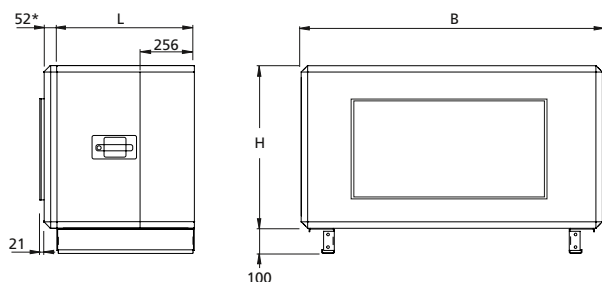

Connection dimensions to duct:
 TCIA 020 1000 x 400 mm
 TCIA 030 1200 x 500 mm
 TCIA 040 1400 x 600 mm
 TCIA 060 1600 x 800 mm

Duct accessories in the lower duct are always delivered with mounted base beam. Duct accessories in the upper duct are always delivered without base beam.

* If several duct accessories are arranged in succession, the end connection panel is supplied only on the duct accessory farthest out facing the ductwork.

TCIA	B	H	L	kg	End connection panel, if required kg
-020	1400	775,5	850	86	19
-030	1600	905,5	850	96	23
-040	1990	1079,5	850	117	34
-060	2318	1144	850	143	34

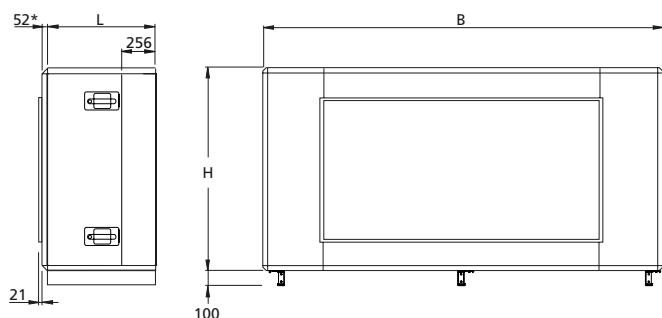

Connection dimensions to duct:
 TCIA 080 1800 x 1000 mm

Duct accessories in the lower duct are always delivered with mounted base beam. Duct accessories in the upper duct are always delivered without base beam.

* If several duct accessories are arranged in succession, the end connection panel is supplied only on the duct accessory farthest out facing the ductwork.

TCIA	B	H	L	kg	End connection panel, if required kg
-080	2637	1320	850	174	40

Complements and Accessories

Duct accessories, in insulated casing

TCDA Unit sound attenuator

The TCDA sound attenuator is a rectangular sound attenuator designed for mounting directly against the air handling unit.

To be installed for horizontal airflow.

Technical data

Insulated casing. The outer skin is made of galvanized sheet steel, re-painted in Swegon's own grey metallic paint (closest comparable RAL colour: 9007). The inner skin is made of aluminium-zinc plated sheet steel. Environmental class C4.

Sound absorption material of type Cleanolon-AL. Cleanolon-AL consists of mineral wool covered with perforated aluminium foil. Type approved with regard to suitability for cleaning, emissions and fibre entrainment. The material conforms to the provisions of Surface Layer Class 1 (the highest class).

Installation

The sound attenuator should be mounted directly against the air handling unit or insulated duct accessory. Provision for inspection and cleaning must be guaranteed. The cover panel is easy to remove.

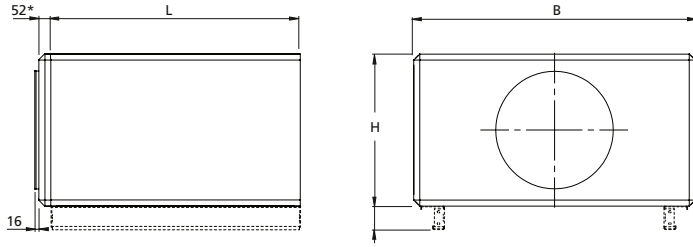

Connection dimensions to duct:

- TCDA 005 \varnothing 315
- TCDA 008 \varnothing 400

Base beam is optional on duct accessories in the lower duct. Duct accessories in the upper duct are always delivered without base beam.
 * If several duct accessories are arranged in succession, the end connection panel is supplied only on the duct accessory farthest out facing the ductwork.

TCDA	B	H	L	kg	End connection panel, if required kg
-005	825	460	975	75	7
-008	995	542,5	975	89	10

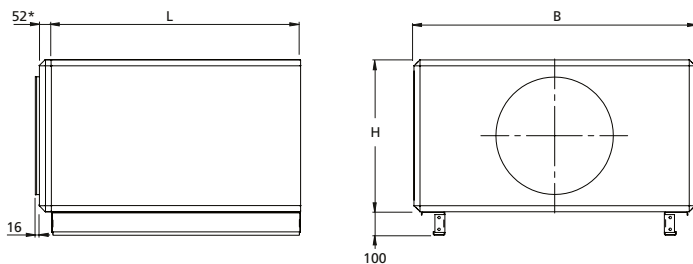

Connection dimensions to duct:

- TCDA 012 \varnothing 500

Duct accessories in the lower duct are always delivered with mounted base beam. Duct accessories in the upper duct are always delivered without base beam.

* If several duct accessories are arranged in succession, the end connection panel is supplied only on the duct accessory farthest out facing the ductwork.

TCDA	B	H	L	kg	End connection panel, if required kg
-012	1199	647,5	975	106	13

Complements and accessories

Duct accessories, in insulated casing

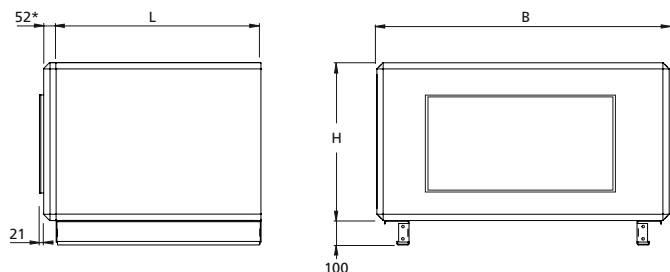

Connection dimensions to duct:
 TCDA 020 1000 x 400 mm
 TCDA 030 1200 x 500 mm
 TCDA 040 1400 x 600 mm
 TCDA 060 1600 x 800 mm

Duct accessories in the lower duct are always delivered with mounted base beam. Duct accessories in the upper duct are always delivered without base beam.

* If several duct accessories are arranged in succession, the end connection panel is supplied only on the duct accessory farthest out facing the ductwork.

TCDA	B	H	L	kg	End connection panel, if required kg
-020	1400	775,5	975	130	19
-030	1600	905,5	975	154	23
-040	1990	1079,5	975	199	34
-060	2318	1144	975	234	34

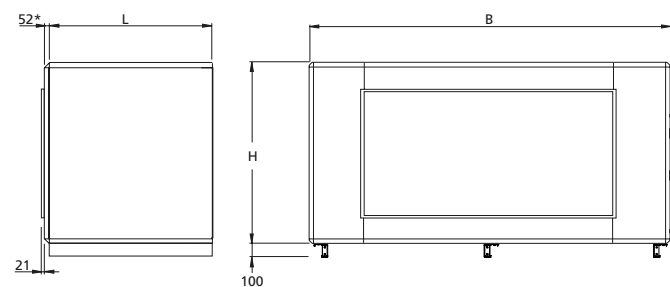

Connection dimensions to duct:
 TCDA 080 1800 x 1000 mm

Duct accessories in the lower duct are always delivered with mounted base beam. Duct accessories in the upper duct are always delivered without base beam.

* If several duct accessories are arranged in succession, the end connection panel is supplied only on the duct accessory farthest out facing the ductwork.

TCDA	B	H	L	kg	End connection panel, if required kg
-080	2637	1320	975	295	40

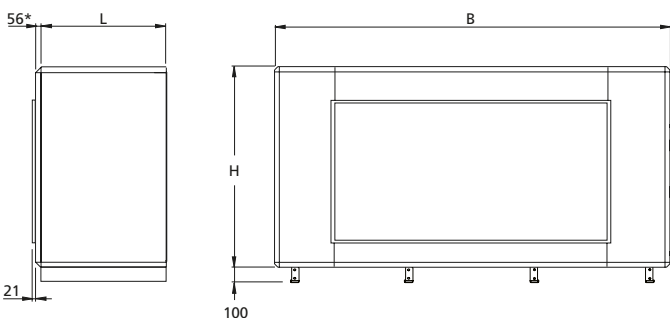

Connection dimensions to duct:
 TCDA 120 2400 x 1200 mm

* If several duct accessories are arranged in succession, the end connection panel is supplied only on the duct accessory farthest out facing the ductwork.

TCDA	B	H	L	kg	End connection panel, if required kg
-120	3340	1620	1070	452	59

Complements and Accessories

Duct accessories, in insulated casing

TCLA Air heater, hot water

The TCLA air heater is used for reheating the supply air. The heater uses hot water as the heating medium.

In many applications it is possible to omit the air heater for reheat if the air handling unit control system is operated in the temperature regulation mode according to the ERS model and when the efficient rotary heat exchanger is in use.

To be installed for horizontal airflow.

Technical data

Insulated casing. The outer skin is made of galvanized sheet steel, re-painted in Swegon's own grey metallic paint (closest comparable RAL colour: 9007). The inner skin is made of aluminium-zinc plated sheet steel. Environmental class C4.

Finned-tube heat exchangers fabricated of copper tubes and profiled aluminium fins. The headers and the pipe-work to the water connections are made of copper. The male threaded pipe connections are made of brass.

The TCLA air heater is available in three capacity variants. Capacity variant 1 provides the lowest capacity and capacity variant 3 provides the highest capacity.

All the air heaters are equipped with individual plugs for venting and drainage. A separate connection is provided for an anti-frost monitor sensor.

Valve set

The TBVL valve set with 2(3)-way valve, actuator, anti-frost protection sensor and connection cable with quick-fit connector can be ordered. If you use a valve of your own, you have the option of instead selecting a set of electrical connection components. This set contains a connection cable with quick-fit connector, resistor and insertion or strap-on sensor.

Extra accessories

A circulation pump is used for guaranteeing the frost guard function, if air heaters without anti-frost burst protection are used. Supplied with T coupling, non-return valve and adjustment valve. The automatic pump control system is integrated into the control equipment of the GOLD unit.

Installation

The air heater should be mounted directly against the air handling unit or insulated duct accessory. Provision for inspection and cleaning must be guaranteed. Electrical connection.



Basic Installation Diagram

Applicable to TCLA 005-012

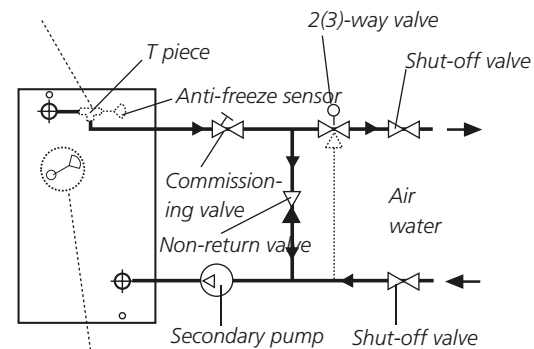

Anti-freeze monitor sensor. Applicable to sizes 014-120

1) The anti-frost protection sensor for the size 005-012 TCLA should be installed in the T-piece on the return pipework and for the size 014-120 TCLA in the connection on the air heater.

Complements and accessories

Duct accessories, in insulated casing

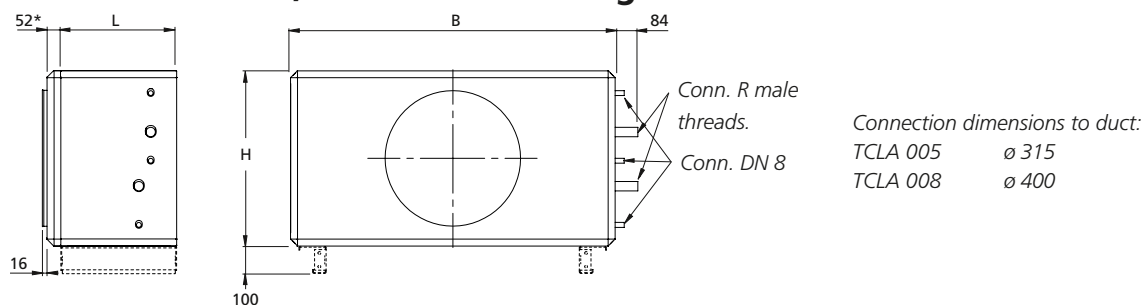

Base beam is optional on duct accessories in the lower duct. Duct accessories in the upper duct are always delivered without base beam.
 * If several duct accessories are arranged in succession, the end connection panel is supplied only on the duct accessory farthest out facing the ductwork.

TCLA	B	H	L	Cap. variant 1		Cap. variant 2		Cap. variant 3		End connection panel, if required kg
				R	kg ¹⁾	R	kg ¹⁾	R	kg ¹⁾	
-005	825	460	400	DN15	33	DN15	34	DN20	36	7
-008	995	542,5	400	DN15	41	DN20	43	DN20	45	10

¹⁾ Not filled with water.

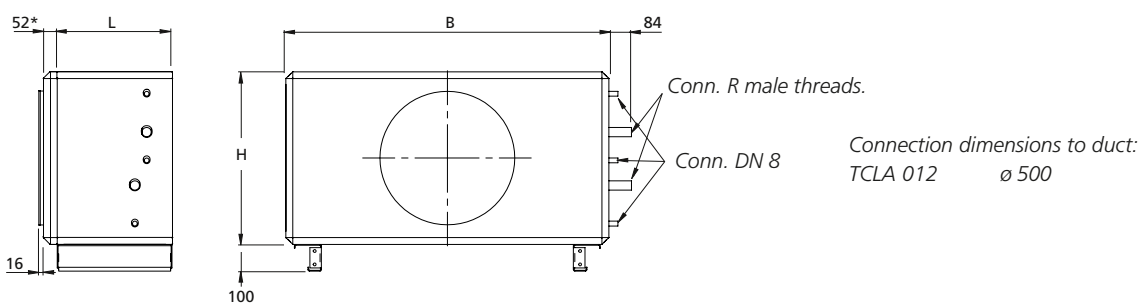

Duct accessories in the lower duct are always delivered with mounted base beam. Duct accessories in the upper duct are always delivered without base beam.

* If several duct accessories are arranged in succession, the end connection panel is supplied only on the duct accessory farthest out facing the ductwork.

TCLA	B	H	L	Cap. variant 1		Cap. variant 2		Cap. variant 3		End connection panel, if required kg
				R	kg ¹⁾	R	kg ¹⁾	R	kg ¹⁾	
-012	1199	647,5	400	DN20	50	DN20	53	DN25	56	13

¹⁾ Not filled with water.

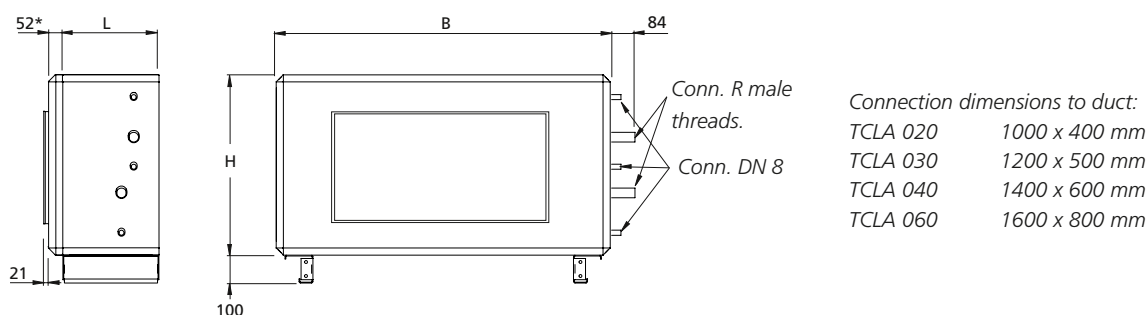

Duct accessories in the lower duct are always delivered with mounted base beam. Duct accessories in the upper duct are always delivered without base beam.

* If several duct accessories are arranged in succession, the end connection panel is supplied only on the duct accessory farthest out facing the ductwork.

TCLA	B	H	L	Cap. variant 1			Cap. variant 2			Cap. variant 3			End connection panel, if required kg
				R	kg ¹⁾	kg ²⁾	R	kg ¹⁾	kg ²⁾	R	kg ¹⁾	kg ²⁾	
-020	1400	775,5	400	DN20	60	-	DN25	65	-	DN25	70	-	19
-030	1600	905,5	400	DN25	70	-	DN32	78	-	DN32	86	-	23
-040	1990	1079,5	400	DN32	89	-	DN40	100	-	DN40	114	-	34
-060	2318	1144	565	DN32	150	112	DN50	161	112	DN50	175	112	34

¹⁾ Not filled with water.

Complements and accessories

Duct accessories, in insulated casing

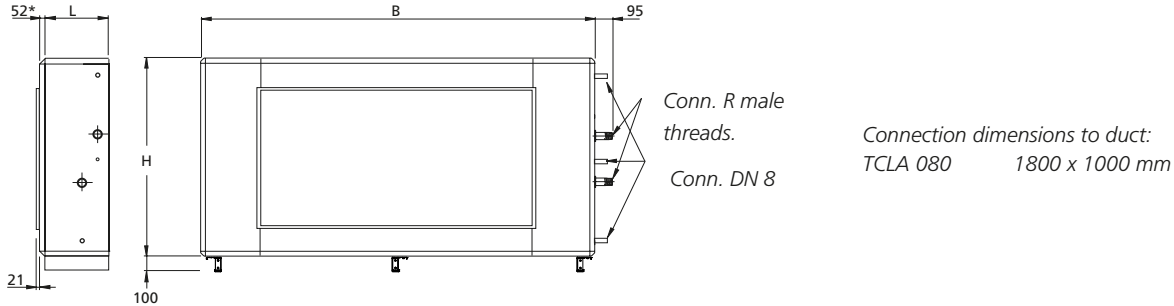

Duct accessories in the lower duct are always delivered with mounted base beam. Duct accessories in the upper duct are always delivered without base beam.

* If several duct accessories are arranged in succession, the end connection panel is supplied only on the duct accessory farthest out facing the ductwork.

TCLA	B	H	L	Capacity variant 1			Capacity variant 2			Capacity variant 3			End connection panel, if required kg
				R	kg ¹⁾	kg ²⁾	R	kg ¹⁾	kg ²⁾	R	kg ¹⁾	kg ²⁾	
-080	2637	1320	565	DN50	181	132	DN65	197	132	DN65	217	132	40

¹⁾ Including casing, not filled with water.

²⁾ Casing only.

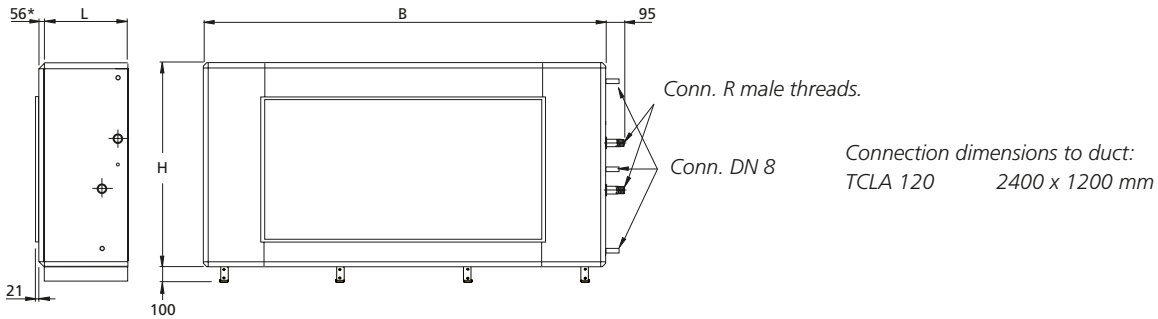

* If several duct accessories are arranged in succession, the end connection panel is supplied only on the duct accessory farthest out facing the ductwork.

TCLA	B	H	L	Capacity variant 1			Capacity variant 2			Capacity variant 3			End connection panel, if required kg
				R	kg ¹⁾	kg ²⁾	R	kg ¹⁾	kg ²⁾	R	kg ¹⁾	kg ²⁾	
-120	3340	1620	720	DN50	339	256	DN65	384	256	DN65	429	256	59

¹⁾ Including casing, not filled with water.

²⁾ Casing only.

Complements and Accessories

Duct accessories, in insulated casing

TCLF Air heater, hot water

The TCLF air heater is used for preheating the supply air. The heater uses hot water as the heating medium. Install the TCLF against the outdoor air duct.

When it is cold outside and the humidity is high, preheating the incoming outdoor air will prevent condensation in the air filters. The function can also be utilised when it is extremely cold outdoors and it is desirable to heat the air up to -20°C, for instance.

In combination with the counterflow heat exchanger, it can also be of interest to preheat the air to be spared having to let it bypass the heat exchanger.

To be installed for horizontal airflow.

Technical data

Insulated casing. The outer skin is made of galvanized sheet steel, re-painted in Swegon's own grey metallic paint (closest comparable RAL colour: 9007). The inner skin is made of aluminium-zinc plated sheet steel. Environmental class C4.

Finned-tube heat exchangers fabricated of copper tubes and profiled aluminium fins. Fin pitch: 4.0 mm. The headers and the pipework to the water connections are made of copper. The male threaded pipe connections are made of brass.

Valve set

The TBVL valve set with 2(3)-way valve, valve actuator, freeze protection sensor and connection cable with quick-fit connector can be ordered. If you use a valve of your own, you can instead select a set of electrical connection components. This set contains a connection cable with quick-fit connector, resistor and insertion type or strap-on sensor.

Extra accessories

Control system, including temperature sensor for duct and IQlogic⁺ with a 0.25 metre long cable, with or without frost guard sensor.

A circulation pump is used for guaranteeing the frost guard function, if air heaters without anti-frost burst protection are used. Supplied with T coupling, non-return valve and adjustment valve. The automatic pump control system is integrated into the control equipment of the GOLD unit.

Installation

The air heater should be mounted directly against the air handling unit or insulated duct accessory. Provision for inspection and cleaning must be guaranteed.

Electrical connection.



Complements and accessories

Duct accessories, in insulated casing

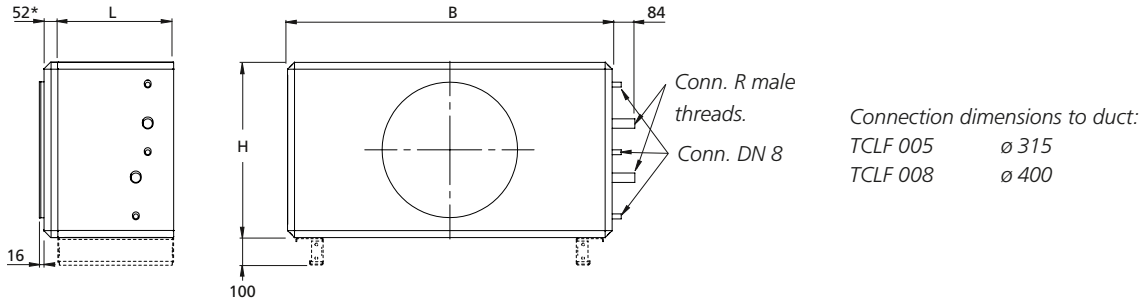

Base beam is optional on duct accessories in the lower duct. Duct accessories in the upper duct are always delivered without base beam.
 * If several duct accessories are arranged in succession, the end connection panel is supplied only on the duct accessory farthest out facing the ductwork.

TCLF	B	H	L	R	kg ¹⁾	End connection panel, if required kg
-005	825	460	400	DN15	33	7
-008	995	542,5	400	DN15	40	10

¹⁾ Not filled with water.

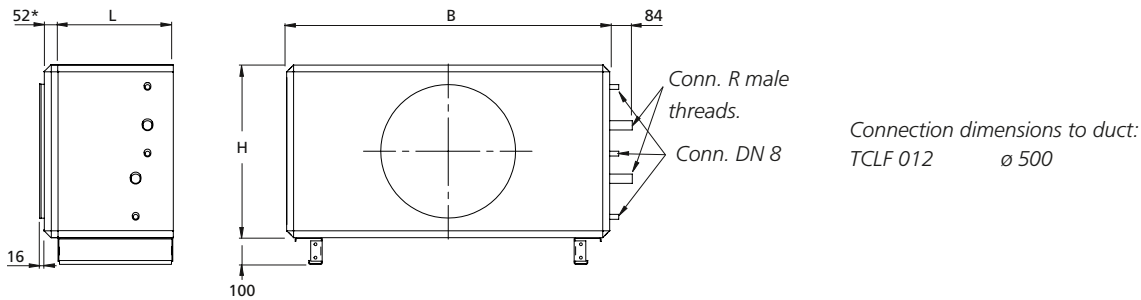

Duct accessories in the lower duct are always delivered with mounted base beam. Duct accessories in the upper duct are always delivered without base beam.
 * If several duct accessories are arranged in succession, the end connection panel is supplied only on the duct accessory farthest out facing the ductwork.

TCLF	B	H	L	R	kg ¹⁾	End connection panel, if required kg
-012	1199	647,5	400	DN20	49	13

¹⁾ Not filled with water.

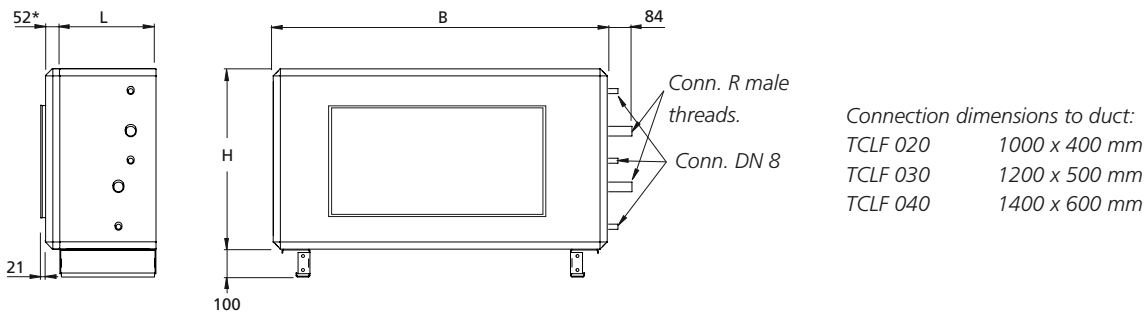

Duct accessories in the lower duct are always delivered with mounted base beam. Duct accessories in the upper duct are always delivered without base beam.
 * If several duct accessories are arranged in succession, the end connection panel is supplied only on the duct accessory farthest out facing the ductwork.

TCLF	B	H	L	R	kg ¹⁾	End connection panel, if required kg
-020	1400	775,5	400	DN20	58	19
-030	1600	905,5	400	DN20	65	23
-040	1990	1079,5	400	DN20	76	34

Complements and Accessories

Duct accessories, in insulated casing

TCLE-02 Electric air heater

Air heater TCLE is used for reheating of the supply air or for certain preheating needs of outdoor air.

In many applications it is possible to omit the air heater for reheat if the air handling unit control system is operated in the temperature regulation mode according to the ERS model and when the efficient rotary heat exchanger is in use.

To be installed for horizontal airflow.

The integrated thyristor is controlled via signals from the GOLD air handling unit. The four, five or six series-coupled overheating protections and control signals are connected by means of a quick connector to the GOLD air handling unit.

Technical data

Insulated casing. The outer skin is made of galvanized sheet steel, re-painted in Swegon's own grey metallic paint (closest comparable RAL colour: 9007). The inner skin is made of aluminium-zinc plated sheet steel. Environmental class C4.

The TCLE air heater is available in several capacity variants.

The electrical equipment conforms to the provisions of Degree of Protection IP44.

The air heater is approved for operating temperatures, in the surroundings and the air stream, from -25°C to +40°C.

Installation

The air heater should be mounted directly against the air handling unit or insulated duct accessory. The space necessary for obtaining a uniform air stream is provided inside the TCLE. Therefore other duct accessories can be fitted downstream of the TCLE without risk of overheating.

Electrical connection. **Power must be supplied directly from the electrical distribution box.**



Complements and accessories

Duct accessories, in insulated casing

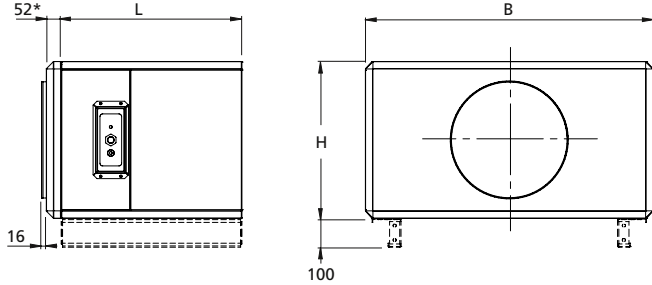

Connection dimensions to duct:
 TCLE 005 ø 315
 TCLE 008 ø 400

Base beam is optional on duct accessories in the lower duct. Duct accessories in the upper duct are always delivered without base beam.
 * If several duct accessories are arranged in succession, the end connection panel is supplied only on the duct accessory farthest out facing the ductwork.

TCLE	B	H	L	kg	End connection panel, if required kg
-005	825	460	625	55-58	7
-008	995	542.5	625	66-72,5	10

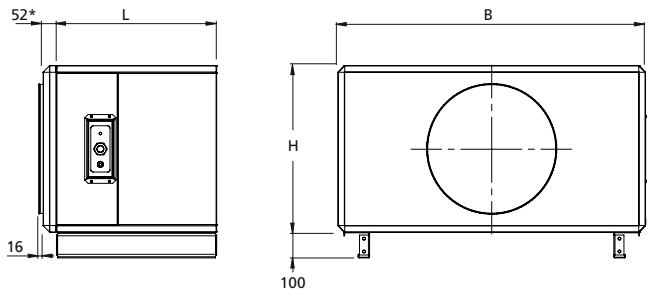

Connection dimensions to duct:
 TCLE 012 ø 500

Duct accessories in the lower duct are always delivered with mounted base beam.
 Duct accessories in the upper duct are always delivered without base beam.
 * If several duct accessories are arranged in succession, the end connection panel is supplied only on the duct accessory farthest out facing the ductwork.

TCLE	B	H	L	kg	End connection panel, if required kg
-012	1199	647.5	625	80-95	13

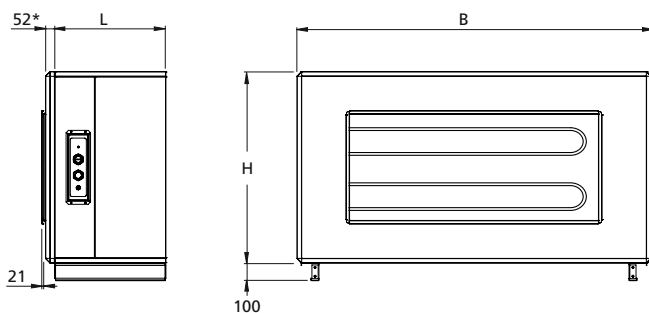

Connection dimensions to duct:
 TCLE 020 1000 x 400 mm
 TCLE 030 1200 x 500 mm
 TCLE 040 1400 x 600 mm
 TCLE 060 1600 x 800 mm

Duct accessories in the lower duct are always delivered with mounted base beam.
 Duct accessories in the upper duct are always delivered without base beam.
 * If several duct accessories are arranged in succession, the end connection panel is supplied only on the duct accessory farthest out facing the ductwork.

TCLE	B	H	L	kg	kg ¹⁾	End connection panel, if required kg
-020	1400	775,5	625	93-115,5	-	19
-030	1600	905.5	625	109-130,5	-	23
-040	1990	1079.5	625	131-163,5	-	34
-060	2318	1144	625	175-213	121	34

¹⁾ Casing only.

Complements and accessories

Duct accessories, in insulated casing

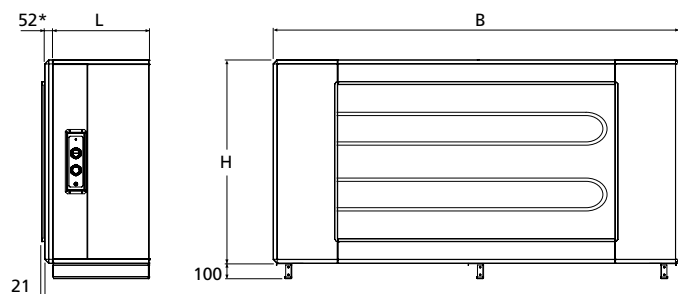

Connection dimensions to duct:
TCLE 080 1800 x 1000 mm

Duct accessories in the lower duct are always delivered with mounted base beam.
Duct accessories in the upper duct are always delivered without base beam.
* If several duct accessories are arranged in succession, the end connection panel is supplied only on the duct accessory farthest out facing the ductwork.

TCLE	B	H	L	kg	kg ¹⁾	End connection panel, if required kg
-080	2637	1320	625	212-248	156	40

¹⁾ Casing only.

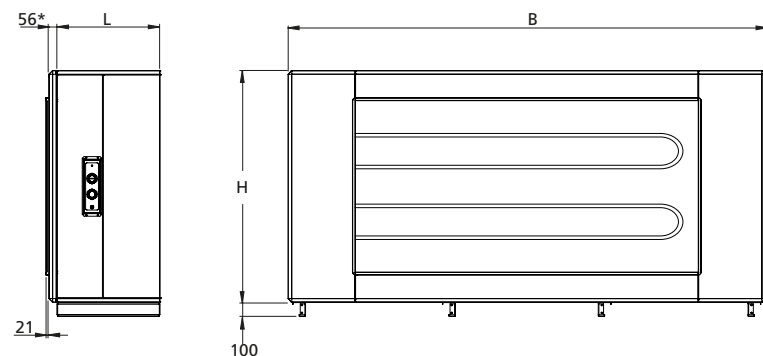

Connection dimensions to duct:
TCLE 120 2400 x 1200 mm

* If several duct accessories are arranged in succession, the end connection panel is supplied only on the duct accessory farthest out facing the ductwork.

TCLE	B	H	L	kg	kg ¹⁾	End connection panel, if required kg
-120	3340	1620	720	336,5-373	267	59

¹⁾ Casing only.

Complements and Accessories

Duct accessories, in insulated casing

TCKA Air cooler (water), TCKC (direct expansion)

The TCKA/TCKC air coolers are used for cooling the supply air with chilled water or evaporative refrigerant as the cooling medium.

The TCKA/TCKC air cooler is available in several capacity variants that cover existing needs for each size of GOLD unit.

The TCKA air coolers are equipped with connections for insertion sensors and can be used as a multi-purpose coil (cooling and heating).

To be installed for horizontal airflow.

Technical data

Insulated casing. The outer skin is made of galvanized sheet steel, re-painted in Swegon's own grey metallic paint (closest comparable RAL colour: 9007). The inner skin is made of aluminium-zinc plated sheet steel. Environmental class C4.

The TCKA/TCKC air coolers are composed of copper tubes and profiled aluminium fins. The TCKA has headers and water connections made of copper/brass, with male connection threads. The TCKC has headers and distributor tubes made of copper. The connections are designed for brazed joints.

Valve set

The TBVL valve set with 2(3)-way valve, actuator and connection cable with quick-fit connector can be ordered for air cooler water. Temperature sensor water for reading incoming or outgoing cooling medium temperatures as an option.

If you use a valve of your own, you can instead select a set of electrical connection components. This set contains a connection cable with quick-fit connector, resistor and insertion type or strap-on sensor.

Installation

The air cooler should be mounted directly against the air handling unit or insulated duct accessory. Provision for inspection and cleaning must be guaranteed.

Connecting the drainage pipework.

Electrical connection.



Complements and accessories

Duct accessories, in insulated casing

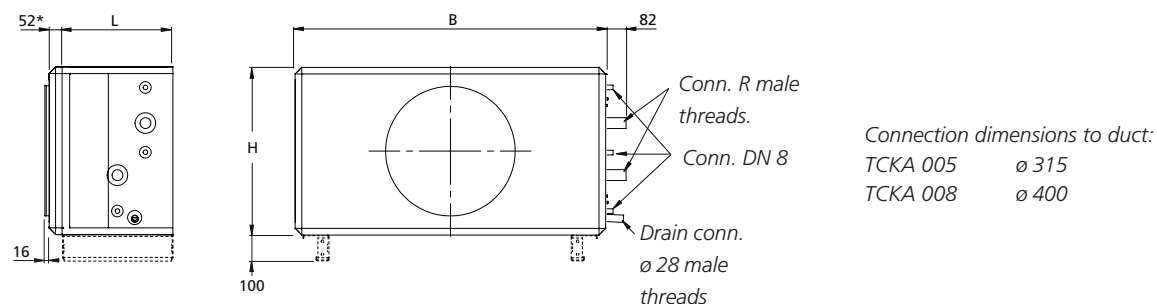

Base beam is optional on duct accessories in the lower duct. Duct accessories in the upper duct are always delivered without base beam.
 * If several duct accessories are arranged in succession, the end connection panel is supplied only on the duct accessory farthest out facing the ductwork.

TCKA	B	H	Cap. variant 1			Cap. variant 2			Cap. variant 4			End connection panel, if required kg
			L	R	kg ¹⁾	L	R	kg ¹⁾	L	R	kg ¹⁾	
-005	825	460	475	DN20	49	475	DN25	51	625	DN25	66	7
-008	995	542,5	475	DN25	60	475	DN25	64	625	DN32	83	10

¹⁾ Excl. cooling agent

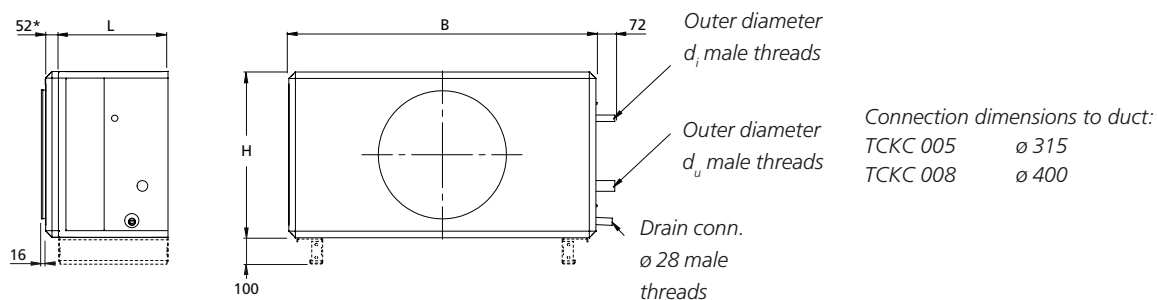

Base beam is optional on duct accessories in the lower duct. Duct accessories in the upper duct are always delivered without base beam.
 * If several duct accessories are arranged in succession, the end connection panel is supplied only on the duct accessory farthest out facing the ductwork.

TCKC	B	H	L	Capacity variant 1			Capacity variant 2			End connection panel, if required kg
				d _i	d _u	kg ¹⁾	d _i	d _u	kg ¹⁾	
-005	825	460	475	1/2"	22	49	5/8"	28	51	7
-008	995	542,5	475	5/8"	28	60	5/8"	35	64	10

¹⁾ Excl. cooling agent

Complements and accessories

Duct accessories, in insulated casing

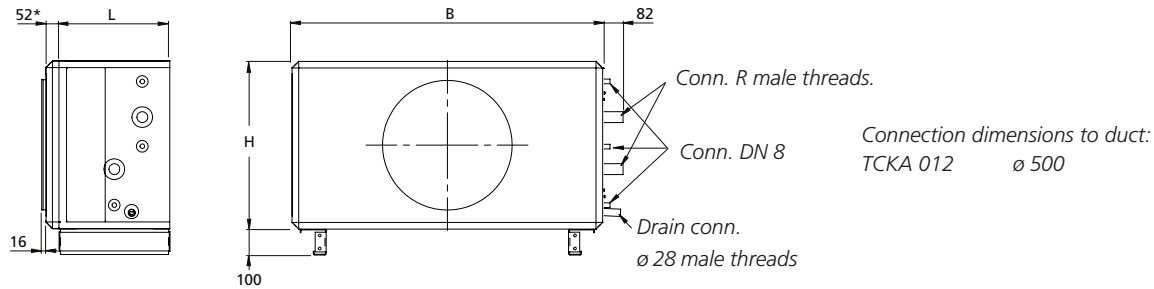

Duct accessories in the lower duct are always delivered with mounted base beam. Duct accessories in the upper duct are always delivered without base beam.

* If several duct accessories are arranged in succession, the end connection panel is supplied only on the duct accessory farthest out facing the ductwork.

TCKA	B	H	Capacity variant 1			Capacity variant 2			Capacity variant 4			End connection panel, if required kg
			L	R	kg ¹⁾	L	R	kg ¹⁾	L	R	kg ¹⁾	
-012	1199	647,5	475	DN25	73	475	DN32	79	625	DN40	106	13

¹⁾ Excl. cooling agent

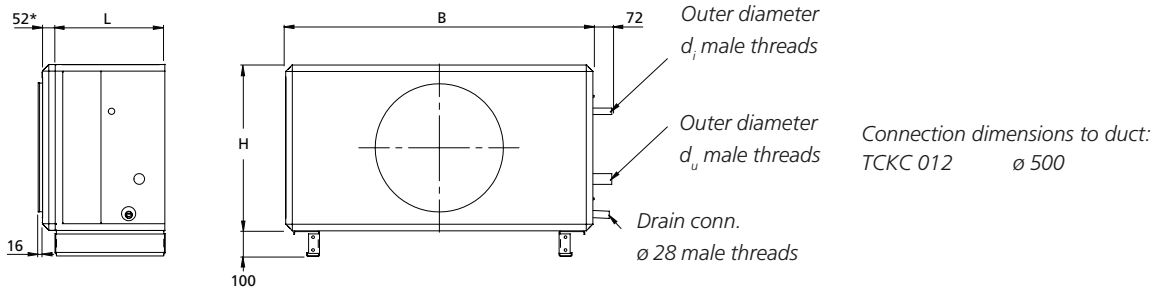

Duct accessories in the lower duct are always delivered with mounted base beam. Duct accessories in the upper duct are always delivered without base beam.

* If several duct accessories are arranged in succession, the end connection panel is supplied only on the duct accessory farthest out facing the ductwork.

TCKC	B	H	L	Capacity variant 1			Capacity variant 2			End connection panel, if required kg
				d _i	d _u	kg ²⁾	d _i	d _u	kg ²⁾	
-012	1199	647,5	475	5/8" ¹⁾	35 ¹⁾	73 ¹⁾	19 ¹⁾	42 ¹⁾	80 ¹⁾	13

¹⁾ If there are two sections: depending on the division of sections

²⁾ Excl. refrigerant

Complements and accessories

Duct accessories, in insulated casing

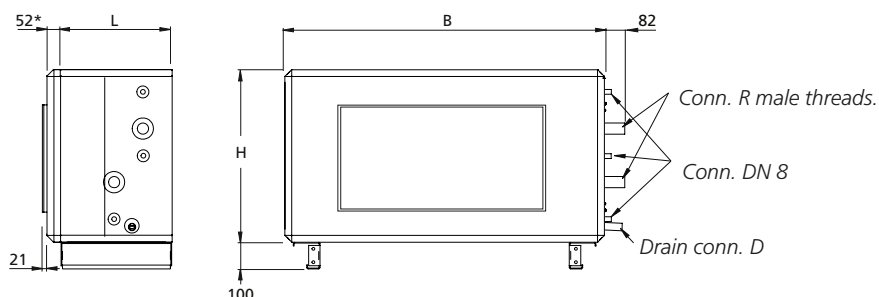

Connection dimensions to duct:
 TCKA 020 1000 x 400 mm
 TCKA 030 1200 x 500 mm
 TCKA 040 1400 x 600 mm
 TCKA 060 1600 x 800 mm

Duct accessories in the lower duct are always delivered with mounted base beam.

Duct accessories in the upper duct are always delivered without base beam.

* If several duct accessories are arranged in succession, the end connection panel is supplied only on the duct accessory farthest out facing the ductwork.

TCKA	B	H	D	Cap. variant 1				Cap. variant 2				Cap. variant 3				Cap. variant 4				End conn. panel if required, kg
				L	R	kg ¹⁾	kg ²⁾	L	R	kg ¹⁾	kg ²⁾	L	R	kg ¹⁾	kg ²⁾	L	R	kg ¹⁾	kg ²⁾	
-020	1400	775,5	28 male threads	475	DN32	91	-	475	DN32	100	-	625	DN40	123	-	625	DN50	132	-	19
-030	1600	905,5	28 male threads	475	DN32	110	-	475	DN40	126	-	625	DN50	156	-	625	DN60	173	-	23
-040	1990	1079,5	28 male threads	475	DN40	138	-	475	DN50	160	-	625	DN65	199	-	625	DN60	223	-	34
-060	2318	1144	DN25	565	DN65	199	108	565	DN65	211	108	565	DN65	225	108	565	DN65	242	108	34

TCKA	B	H	D	Cap. variant 1				Cap. variant 2				End connection panel if required, kg
				L	R	kg ¹⁾	kg ²⁾	L	R	kg ¹⁾	kg ²⁾	
-060	2318	1144	DN25	565	DN65	210	108	565	DN65	230	108	34

¹⁾ Excl. cooling agent

²⁾ Only casing.

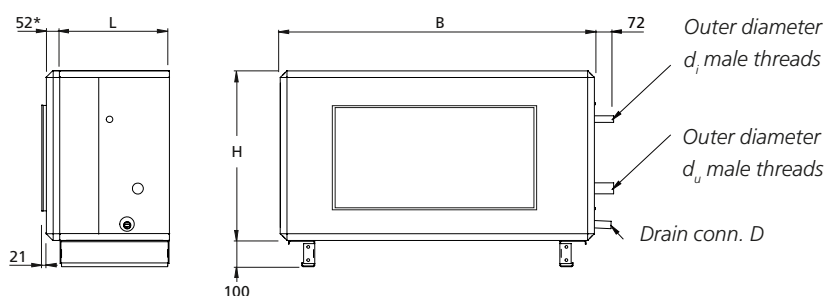

Connection dimensions to duct:
 TCKC 020 1000 x 400 mm
 TCKC 030 1200 x 500 mm
 TCKC 040 1400 x 600 mm
 TCKC 060 1600 x 800 mm

Duct accessories in the lower duct are always delivered with mounted base beam.

Duct accessories in the upper duct are always delivered without base beam.

* If several duct accessories are arranged in succession, the end connection panel is supplied only on the duct accessory farthest out facing the ductwork.

TCKC	B	H	L	D	Cap. variant 1				Cap. variant 2				Cap. variant 3				End conn. panel, if required kg
					d _i	d _u	kg ²⁾	kg ³⁾	d _i	d _u	kg ²⁾	kg ³⁾	kg ²⁾	kg ³⁾			
-020	1400	775,5	475	28 male threads	22 ¹⁾	42 ¹⁾	94 ¹⁾	-	28 ¹⁾	54 ¹⁾	104 ¹⁾	-	-	-	19		
-030	1600	905,5	475	28 male threads	28 ¹⁾	54 ¹⁾	115 ¹⁾	-	28 ¹⁾	54 ¹⁾	128 ¹⁾	-	-	-	23		
-040	1990	1079,5	475	28 male threads	28 ¹⁾	54 ¹⁾	147 ¹⁾	-	28 ¹⁾	54 ¹⁾	167 ¹⁾	-	-	-	34		
-060	2318	1144	565	DN25	-	-	210	108	-	-	230	108	248	108	34		

¹⁾ If there are two sections: depending on the division of sections

²⁾ Excl. refrigerant

³⁾ Only casing

Complements and accessories

Duct accessories, in insulated casing

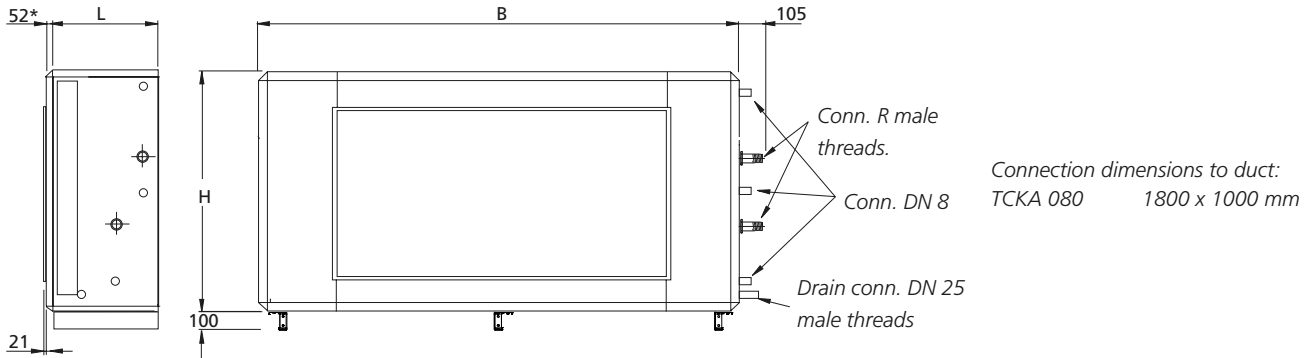

Duct accessories in the lower duct are always delivered with mounted base beam. Duct accessories in the upper duct are always delivered without base beam.

* If several duct accessories are arranged in succession, the end connection panel is supplied only on the duct accessory farthest out facing the ductwork.

TCKA	B	H	L	Cap. variant 1			Cap. variant 2			Cap. variant 3			Cap. variant 4			End connection panel, if required kg
				R	kg ¹⁾	kg ²⁾	R	kg ¹⁾	kg ²⁾	R	kg ¹⁾	kg ²⁾	R	kg ¹⁾	kg ²⁾	
-080	2637	1320	565	DN65	263	135	DN65	282	135	DN65	302	135	DN65	324	135	40

¹⁾ Including casing, not charged with refrigerant.

²⁾ Casing only.

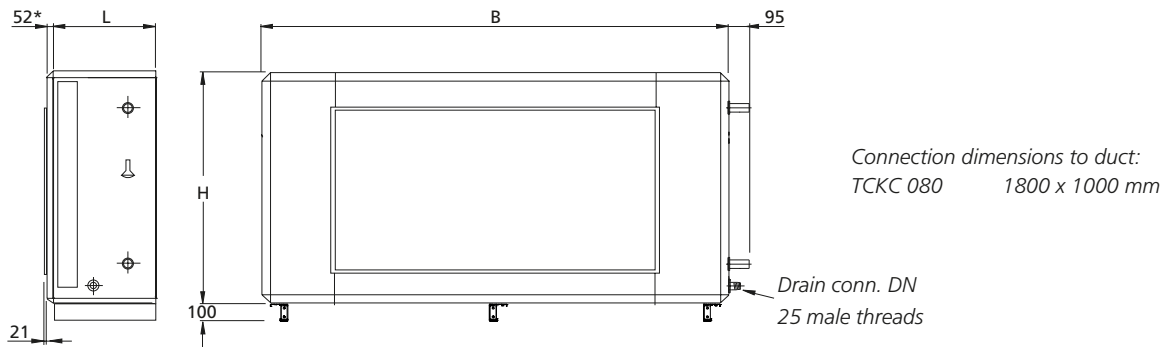

Duct accessories in the lower duct are always delivered with mounted base beam. Duct accessories in the upper duct are always delivered without base beam.

* If several duct accessories are arranged in succession, the end connection panel is supplied only on the duct accessory farthest out facing the ductwork.

TCKC	B	H	L	Cap. variant 1		Cap. variant 2		Cap. variant 3		End connection panel, if required kg
				kg ¹⁾	kg ²⁾	kg ¹⁾	kg ²⁾	kg ¹⁾	kg ²⁾	
-080	2637	1320	565	280	135	316	135	332	135	40

¹⁾ Including casing, not charged with refrigerant.

²⁾ Casing only.

Complements and accessories

Duct accessories, in insulated casing

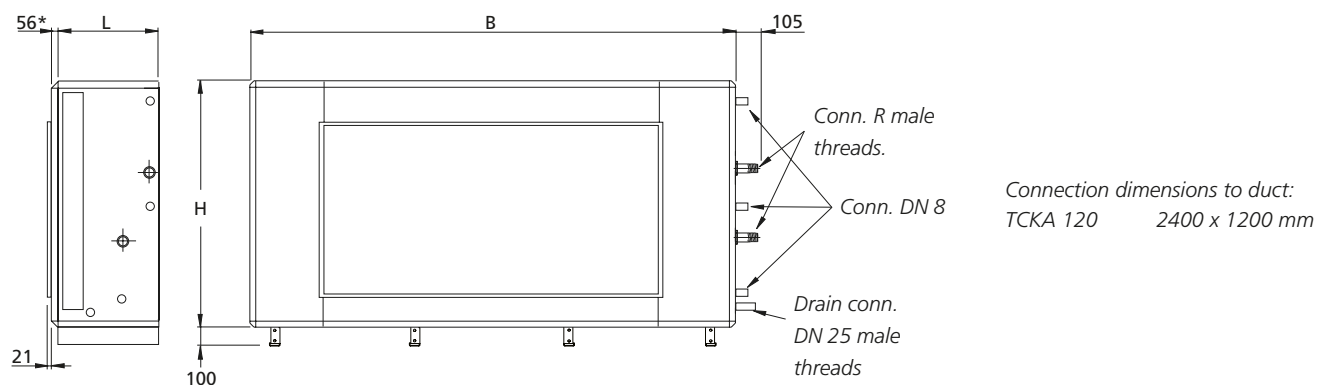

* If several duct accessories are arranged in succession, the end connection panel is supplied only on the duct accessory farthest out facing the ductwork.

TCKA	B	H	L	Capacity variant 1			Capacity variant 2			Capacity variant 3			Capacity variant 4			End connection panel, if required kg
				R	kg ¹⁾	kg ²⁾	R	kg ¹⁾	kg ²⁾	R	kg ¹⁾	kg ²⁾	R ³⁾	kg ¹⁾	kg ²⁾	
-120	3340	1620	720	DN65	414	260	DN80	461	260	DN80	513	260	DN100	568	260	59

¹⁾ Including casing, not charged with refrigerant.

²⁾ Casing only.

³⁾ The flange is included.

Complements and accessories

Duct accessories, in insulated casing

TCCC Air heater/air cooler (direct expansion)

TCCC air heaters/air coolers are used for heating and cooling the supply air in combination with a Echos+ chiller/heat pump and SMART Link DX control function. Evaporating cooling medium.

To be installed for horizontal airflow.

Technical data

Insulated casing. The outer skin is made of galvanized sheet steel, re-painted in Swegon's own grey metallic paint (closest comparable RAL colour: 9007). The inner skin is made of aluminium-zinc plated sheet steel. Environmental Class C4.

TCCC air heaters/air coolers are composed of copper tubes and profiled aluminium fins. The TCCC coils have headers and distributor tubes made of copper. The connections are designed for brazed joints.

Installation

The air heater/air cooler should be mounted directly against the air handling unit or insulated duct accessory. Provision for inspection and cleaning must be guaranteed. Connecting the drainage pipework.



Complements and accessories

Duct accessories, in insulated casing

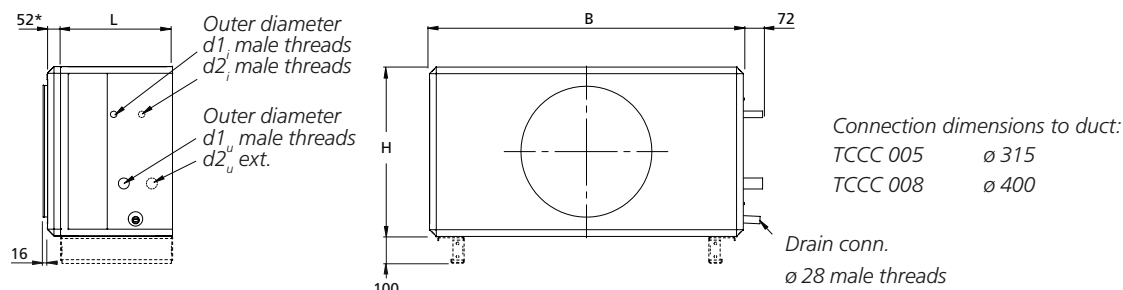

Base beam is optional on duct accessories in the lower duct. Duct accessories in the upper duct are always delivered without base beam.
 * If several duct accessories are arranged in succession, the end connection panel is supplied only on the duct accessory farthest out facing the ductwork.

TCCC	B	H	L	kg ¹⁾	End connection panel, if required kg
-005	825	460	475	43	7
-008	995	542,5	475	50 - 53	10

Echos+ size	d _i	d _u
9	16	22
15	22	28

¹⁾ Excl. cooling agent

Connection diameter varies depending on combination of quantity/sizes of Echos+ chillers/heat pumps.

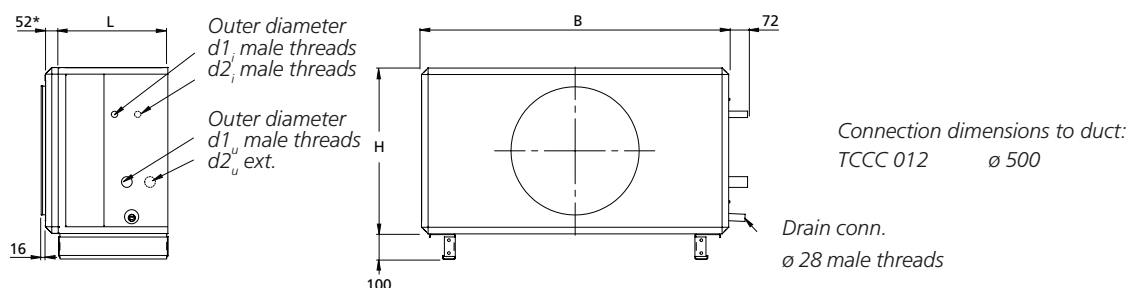

Duct accessories in the lower duct are always delivered with mounted base beam. Duct accessories in the upper duct are always delivered without base beam.
 * If several duct accessories are arranged in succession, the end connection panel is supplied only on the duct accessory farthest out facing the ductwork.

TCCC	B	H	L	kg ¹⁾	End connection panel, if required kg
-012	1199	647,5	475	58 - 60	13

Echos+ size	d _i	d _u
9	16	22
15	22	28

¹⁾ Excl. cooling agent

Connection diameter varies depending on combination of quantity/sizes of Echos+ chillers/heat pumps.

Complements and accessories

Duct accessories, in insulated casing

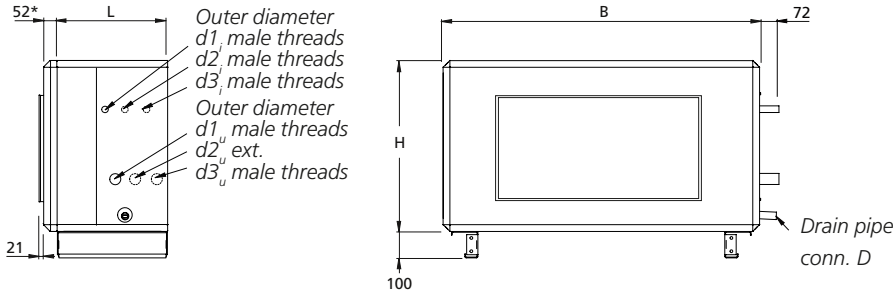

Connection dimensions to duct:

TCCC 020	1000 x 400 mm
TCCC 030	1200 x 500 mm
TCCC 040	1400 x 600 mm
TCCC 060	1600 x 800 mm

Duct accessories in the lower duct are always delivered with mounted base beam. Duct accessories in the upper duct are always delivered without base beam.

* If several duct accessories are arranged in succession, the end connection panel is supplied only on the duct accessory farthest out facing the ductwork.

TCCC	B	H	L	D	kg ¹⁾	End connection panel, if required kg
-020	1400	775,5	475	28 male threads	71 - 75	19
-030	1600	905,5	475	28 male threads	81 - 87	23
-040	1990	1079,5	475	28 male threads	98 - 106	34
-060	2318	1144	565	DN25	130-148	34

Echos+ size	d _i	d _u
9	16	22
15	22	28
20	22	28
26	28	35
30	28	35

Connection diameter varies depending on combination of quantity/sizes of Echos+ chillers/heat pumps.

¹⁾ Excl. cooling agent

Complements and Accessories

Duct accessories, in insulated casing

TCEK-02 Coil section

Electric heating and water-borne cooling

The TCEK coil section is used for heating/cooling the supply air. The air heater runs on electric power and its type designation is TCLE. The cooling coil is a type TCKA air cooler for chilled water or a type TCKA air cooler for evaporative refrigerant. The type TCKA air coolers are equipped with connections for insertion sensors and can be used as a multi-purpose coil (cooling and heating).

To be installed for horizontal airflow.

The integrated thyristor is controlled via signals from the GOLD air handling unit. The four, five or six series-coupled overheating protections and control signals are connected by means of a quick connector to the GOLD air handling unit.

Technical data

Insulated casing. The outer skin is made of galvanized sheet steel, re-painted in Swegon's own grey metallic paint (closest comparable RAL colour: 9007). The inner skin is made of aluminium-zinc plated sheet steel. Environmental class C4.

The electric air heater is available in several capacity variants; the electrical equipment conforms to the provisions of Degree of Protection IP44.

The air heater is approved for operating temperatures, in the surroundings and the air stream, from -25°C to +40°C.

The air cooler is composed of copper tubes and profiled aluminium fins. The air cooler for chilled water has headers and water connections made of copper/brass, with male connection threads.

The air cooler for evaporative refrigerant has headers and distributor tubes made of copper. The connections are designed for brazed joints.

The air cooler is available in several capacity variants that cover existing needs for each size of GOLD unit.

Valve set

The TBVL valve set with 2(3)-way valve, actuator and connection cable with quick-fit connector can be ordered for air cooler water. Temperature sensor water for reading incoming or outgoing cooling medium temperatures as an option.

If you use a valve of your own, you can instead select a set of electrical connection components. This set contains a connection cable with quick-fit connector, resistor and insertion type or strap-on sensor.



Installation

The coil section should be mounted directly against the air handling unit or insulated duct accessory. Provision for inspection and cleaning must be guaranteed.

Electrical connection. **Power must be supplied to the electric air heater directly from an electrical distribution box.**

Complements and accessories

Duct accessories, in insulated casing

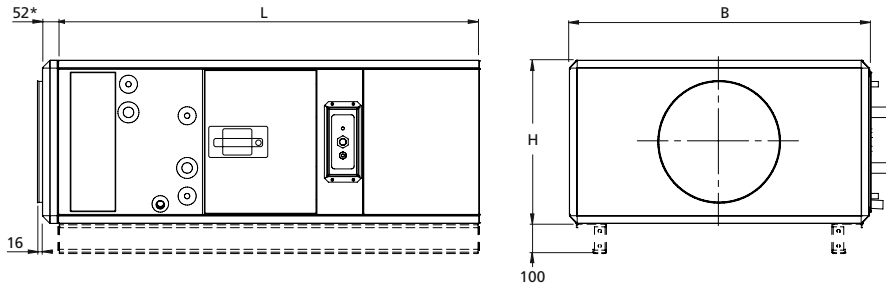

Connection dimensions to duct:
 TCEK 005 ø 315
 TCEK 008 ø 400

Base beam is optional on duct accessories in the lower duct. Duct accessories in the upper duct are always delivered without base beam.
 * If several duct accessories are arranged in succession, the end connection panel is supplied only on the duct accessory farthest out facing the ductwork.

TCEK	B	H	L	kg ¹⁾	End connection panel, if required kg
-005	825	460	1400	123-132	7
-008	995	542.5	1400	142-161,5	10

¹⁾ Excl. cooling agent.
 For particulars of the pipe dimensions, see the corresponding TCKA or TCKC.

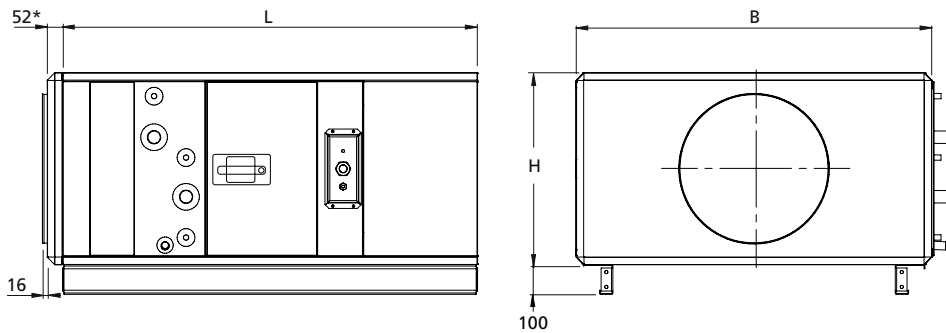

Connection dimensions to duct:
 TCEK 012 ø 500

Duct accessories in the lower duct are always delivered with mounted base beam.
 Duct accessories in the upper duct are always delivered without base beam.
 * If several duct accessories are arranged in succession, the end connection panel is supplied only on the duct accessory farthest out facing the ductwork.

TCEK	B	H	L	kg ¹⁾	End connection panel, if required kg
-012	1199	647.5	1400	176-194	13

¹⁾ Excl. cooling agent.
 For particulars of the pipe dimensions, see the corresponding TCKA or TCKC.

Complements and accessories

Duct accessories, in insulated casing

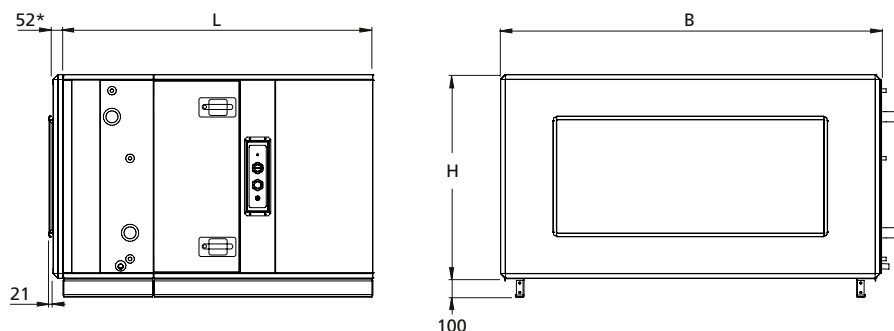

Connection dimensions to duct:
 TCEK 020 1000 x 400 mm
 TCEK 030 1200 x 500 mm
 TCEK 040 1400 x 600 mm
 TCEK 060 1600 x 800 mm

Duct accessories in the lower duct are always delivered with mounted base beam.

Duct accessories in the upper duct are always delivered without base beam.

* If several duct accessories are arranged in succession, the end connection panel is supplied only on the duct accessory farthest out facing the ductwork.

TCEK	B	H	L	kg ¹⁾	kg ²⁾	End connection panel, if required kg
-020 ³⁾	1400	775.5	1625	237 - 268,5	-	19
-020 ³⁾	1400	775.5	1775	255 - 286,5	-	19
-030 ³⁾	1600	905.5	1625	271 - 308,5	-	23
-030 ³⁾	1600	905.5	1775	300 - 338,5	-	23
-040 ³⁾	1990	1079.5	1625	339 - 402,5	-	34
-040 ³⁾	1990	1079.5	1775	400 - 465,5	-	34
-060 ⁴⁾	2318	1144	1755	481 - 535	336	34
-060 ⁴⁾	2318	1144	1965	543 - 593	362	34

¹⁾ Including casing, not charged with refrigerant.

²⁾ Casing only.

³⁾ Dimension L = 1,775 mm applies to capacity variants 3 and 4 in versions with waterborne air cooler (type TCKA). For the others, L = 1625 mm.

⁴⁾ Dimension L = 1,965 mm applies to capacity variants 3 and 4 in versions with waterborne air cooler (type TCKA). For the others, L = 1755 mm. For particulars of the pipe dimensions, see the corresponding TCKA or TCKC.

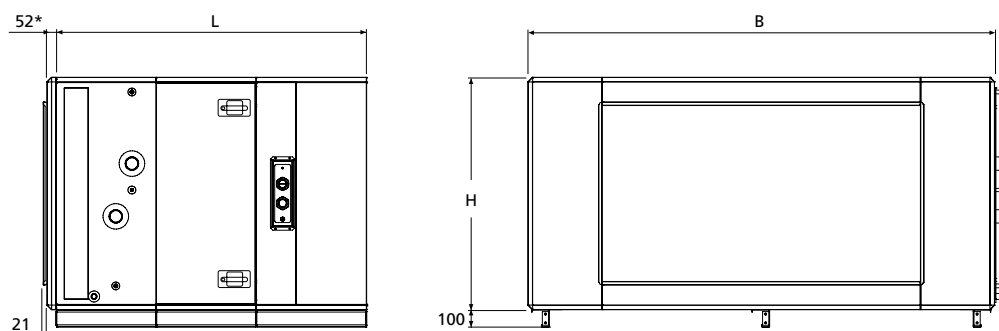

Connection dimensions to duct:
 TCEK 080 1800 x 1000 mm

Duct accessories in the lower duct are always delivered with mounted base beam.

Duct accessories in the upper duct are always delivered without base beam.

* If several duct accessories are arranged in succession, the end connection panel is supplied only on the duct accessory farthest out facing the ductwork.

TCEK	B	H	L	kg ¹⁾	kg ²⁾	End connection panel, if required kg
-080 ³⁾	2637	1320	1755	618 - 714	425	40
-080 ³⁾	2637	1320	1965	702 - 831	456	40

¹⁾ Including casing, not charged with refrigerant.

²⁾ Casing only.

³⁾ Dimension L = 1,965 mm applies to capacity variants 3 and 4 in versions with waterborne air cooler (type TCKA). For the others, L = 1755 mm. For particulars of the pipe dimensions, see the corresponding TCKA or TCKC.

Complements and Accessories

Duct accessories, in insulated casing

Coil section TCLK

Waterborne heating and cooling

The TCLK coil section is used for heating/cooling the supply air. The air heater is for hot water and its type designation is TCLA. The air cooler is of type TCKA for chilled water or of type TCKC for evaporative refrigerant. The type TCKA air coolers are equipped with connections for insertion sensors and can be used as a multi-purpose coil (cooling and heating).

To be installed for horizontal airflow.

Technical data

Insulated casing. The outer skin is made of galvanized sheet steel, re-painted in Swegon's own grey metallic paint (closest comparable RAL colour: 9007). The inner skin is made of aluminium-zinc plated sheet steel. Environmental Class C4.

The air heater is a finned-tube heat exchanger fabricated of copper tubes and profiled aluminium fins. The headers and the pipework to the water connections are made of copper. The male threaded pipe connections are made of brass.

The air heater is available in three capacity variants. Capacity variant 1 provides the lowest capacity and capacity variant 3 provides the highest capacity.

The air heaters and air coolers are equipped with individual plugs for venting and drainage. A separate connection is provided for an anti-frost monitor sensor.

The air cooler is composed of copper tubes and profiled aluminium fins. The air cooler for chilled water has headers and water connections made of copper/brass, with male connection threads.

The air cooler for evaporative refrigerant has headers and distributor tubes made of copper. The connections are designed for brazed joints.

The air cooler is available in several capacity variants that cover existing needs for each size of GOLD unit.

Valve set

The TBVL valve set with 2(3)-way valve, actuator, connection cable with quick-fit connector and temperature sensor water if required can be ordered for air heaters and air coolers water. For 2-pipe systems, (1 valve set) the valve set should be ordered with temperature sensor water. For 4-pipe systems, (2 valve sets) one valve set should be ordered with temperature sensor water (heating circuit) and one valve set without temperature sensor water (cooling circuit).

If you use a valve of your own, you can instead select a set of electrical connection components. This set contains a connection cable with quick-fit connector, resistor and insertion type or strap-on sensor.



Extra accessories

A circulation pump is used for guaranteeing the frost guard function, if air heaters without anti-frost burst protection are used. Supplied with T coupling, non-return valve and adjustment valve. The automatic pump control system is integrated into the control equipment of the GOLD unit.

Installation

The coil section should be mounted directly against the air handling unit or insulated duct accessory. Provision for inspection and cleaning must be guaranteed.

Electrical connection.

Complements and accessories

Duct accessories, in insulated casing

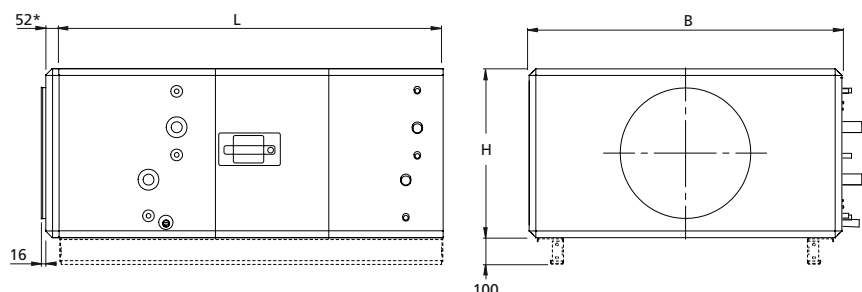

Connection dimensions to duct:
 TCLK 005 \varnothing 315
 TCLK 008 \varnothing 400

Base beam is optional on duct accessories in the lower duct. Duct accessories in the upper duct are always delivered without base beam.
 * If several duct accessories are arranged in succession, the end connection panel is supplied only on the duct accessory farthest out facing the ductwork.

TCLK	B	H	L	kg ¹⁾	End connection panel, if required kg
-005	825	460	1150	93-103	7
-008	995	542,5	1150	115-131	10

¹⁾ Excl. water/cooling agent.
 For particulars of the pipe dimensions, see the corresponding TCLA and TCKA or TCKC.

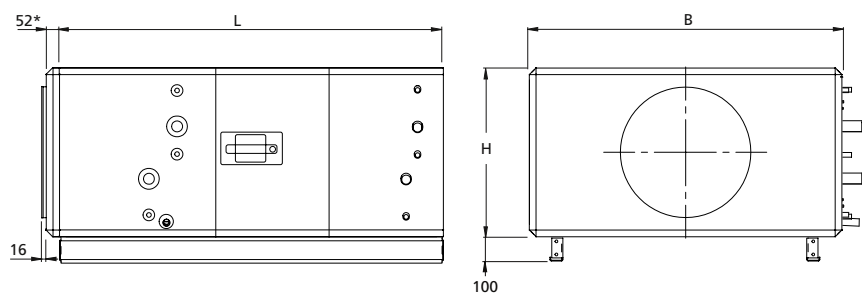

Connection dimensions to duct:
 TCLK 012 \varnothing 500

Duct accessories in the lower duct are always delivered with mounted base beam. Duct accessories in the upper duct are always delivered without base beam.
 * If several duct accessories are arranged in succession, the end connection panel is supplied only on the duct accessory farthest out facing the ductwork.

TCLK	B	H	L	kg ¹⁾	End connection panel, if required kg
-012	1199	647,5	1150	140-165	13

¹⁾ Excl. water/cooling agent.
 For particulars of the pipe dimensions, see the corresponding TCLA and TCKA or TCKC.

Complements and accessories

Duct accessories, in insulated casing

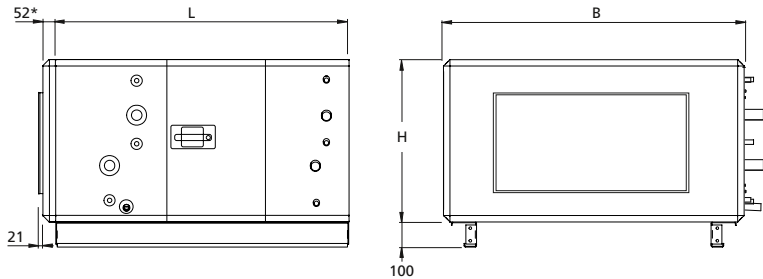

Connection dimensions to duct:
 TCLK 020 1000 x 400 mm
 TCLK 030 1200 x 500 mm
 TCLK 040 1400 x 600 mm
 TCLK 060 1600 x 800 mm

Duct accessories in the lower duct are always delivered with mounted base beam.
 Duct accessories in the upper duct are always delivered without base beam.

* If several duct accessories are arranged in succession, the end connection panel is supplied only on the duct accessory farthest out facing the ductwork.

TCLK	B	H	L	kg ¹⁾	kg ²⁾	End connection panel, if required kg
-020 ³⁾	1400	775,5	1325	192 - 212	-	19
-020 ³⁾	1400	775,5	1475	225 - 245	-	19
-030 ⁴⁾	1600	905,5	1325	228 - 259	-	23
-030 ⁴⁾	1600	905,5	1475	275 - 308	-	23
-040 ⁵⁾	1990	1079.5	1325	228 - 329	-	34
-040 ⁵⁾	1990	1079.5	1475	343 - 392	-	34
-060	2318	1144	1695	452-520	353	34

¹⁾ Including casing, excluding water/cooling agent.

²⁾ Casing only

³⁾ Dimension L = 1475 mm applies to air heaters in the capacity variants 1-3 in combination with air coolers in the capacity variants 3-4. For the others, L = 1325 mm.

⁴⁾ Dimension L = 1475 mm applies to air heaters in the capacity variants 1-3 in combination with air coolers in the capacity variants 3-4. For the others, L = 1325 mm.

⁵⁾ Dimension L = 1475 mm applies to air heaters in the capacity variants 1-3 in combination with air coolers in the capacity variants 3-4. For the others, L = 1325 mm.

For particulars of the pipe dimensions, see the corresponding TCLA and TCKA or TCKC.

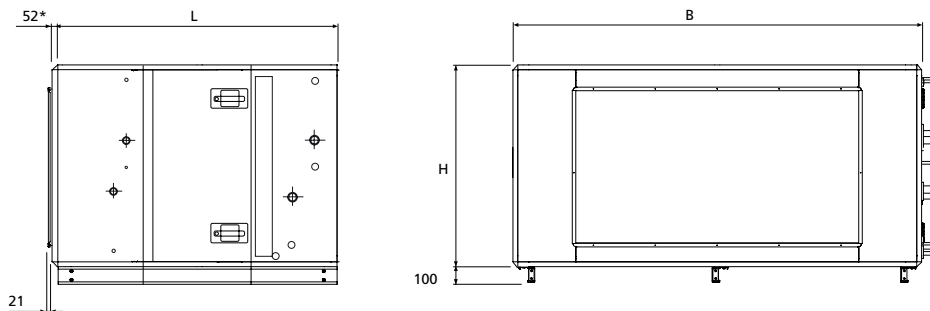

Connection dimensions to duct:
 TCLK 080 1800 x 1000 mm

Duct accessories in the lower duct are always delivered with mounted base beam.
 Duct accessories in the upper duct are always delivered without base beam.

* If several duct accessories are arranged in succession, the end connection panel is supplied only on the duct accessory farthest out facing the ductwork.

TCLK	B	H	L	kg ¹⁾	kg ²⁾	End connection panel, if required kg
-080	2637	1320	1695	395	572 - 677	40

¹⁾ Casing only.

²⁾ Including casing, not filled with water/not charged with refrigerant

For particulars of the pipe dimensions, see the corresponding TCLA and TCKA or TCKC.

Complements and Accessories

Duct accessories, in insulated casing

Final filter section, TCFB

The TCFB final filter section should be installed in ventilation systems where further filtration of the supply air is required.

Install the final filter section in the supply air downstream of the air handling unit.

Prefitted pressure sensor is standard. The alarm limit and current filter pressure can be read on the hand-held micro terminal of the GOLD unit.

To be installed for horizontal airflow.

Technical data

Insulated casing. The outer skin is made of galvanized sheet steel, re-painted in Swegon's own grey metallic paint (closest comparable RAL colour: 9007). The inner skin is made of aluminium-zinc plated sheet steel. Environmental Class C4. Bag filters to filter class ePM1 50% (F7) or ePM1 85% (F9) can be selected.



Installation

The final filter section should be mounted directly against the air handling unit or an insulated duct accessory. Connect the pressure sensor.

Provision for inspection and cleaning must be guaranteed.

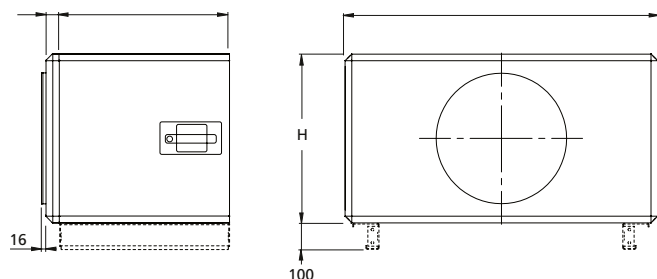

Connection dimensions to duct:

- TCFB 005 \varnothing 315
- TCFB 008 \varnothing 400

Base beam is optional on duct accessories in the lower duct. Duct accessories in the upper duct are always delivered without base beam.
 * If several duct accessories are arranged in succession, the end connection panel is supplied only on the duct accessory farthest out facing the ductwork.

TCFB	B	H	L	kg	End connection panel, if required
					kg
-005	825	460	720	52	7
-008	995	542,5	720	58	10

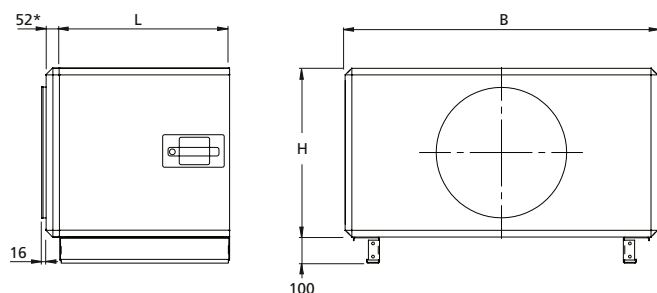

Connection dimensions to duct:

- TCFB 012 \varnothing 500

Duct accessories in the lower duct are always delivered with mounted base beam. Duct accessories in the upper duct are always delivered without base beam.

* If several duct accessories are arranged in succession, the end connection panel is supplied only on the duct accessory farthest out facing the ductwork.

TCFB	B	H	L	kg	End connection panel, if required
					kg
-012	1199	647,5	720	72	13

Complements and accessories

Duct accessories, in insulated casing

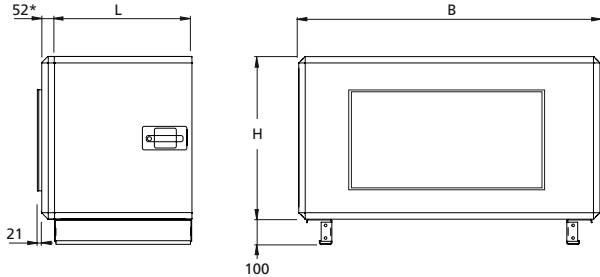

Connection dimensions to duct:
 TCFB 020 1000 x 400 mm
 TCFB 030 1200 x 500 mm
 TCFB 040 1400 x 600 mm
 TCFB 060 1600 x 800 mm

Duct accessories in the lower duct are always delivered with mounted base beam.
 Duct accessories in the upper duct are always delivered without base beam.
 * If several duct accessories are arranged in succession, the end connection panel is supplied only on the duct accessory farthest out facing the ductwork.

TCFB	B	H	L	kg	End connection panel, if required kg
-020	1400	775,5	720	88	19
-030	1600	905,5	720	103	23
-040	1990	1079,5	720	119	34
-060	2318	1144	720	150	34

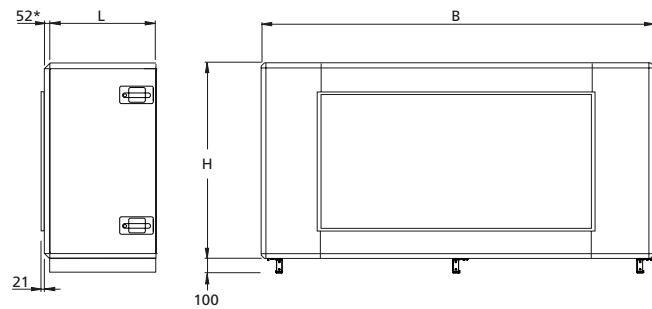

Connection dimensions to duct:
 TCFB 080 1800 x 1000 mm

Duct accessories in the lower duct are always delivered with mounted base beam.
 Duct accessories in the upper duct are always delivered without base beam.
 * If several duct accessories are arranged in succession, the end connection panel is supplied only on the duct accessory farthest out facing the ductwork.

TCFB	B	H	L	kg	End connection panel, if required kg
-080	2637	1320	720	198	40

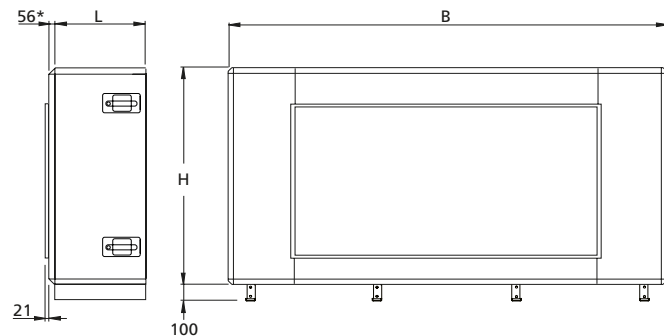

Connection dimensions to duct:
 TCFB 120 2400 x 1200 mm

* If several duct accessories are arranged in succession, the end connection panel is supplied only on the duct accessory farthest out facing the ductwork.

TCFB	B	H	L	kg	End connection panel, if required kg
-120	3340	1620	720	297	59

Complements and Accessories

Duct accessories

TBFK Carbon filter section

The TBFK has activated carbon filter medium designed for improving the air quality indoors by adsorbing gaseous, harmful or foul-smelling substances from the air.

Note that we cannot guarantee one hundred percent elimination of odours due to variations in the impurities and mixtures of various chemical substances arrested in the filter.

The carbon filter cartridges are disposable. They are seated in mounting frames and can be locked in their bayonet socket by simply turning them by hand. The cartridges contain a filter mat made of polyester, which encloses the activated carbon.

The frame structure consists of 38 mm galvanized (Sendzimir) square profiled sections, painted in RAL 7032. The profiled sections are held together by corner pieces made of plastic.

The outer and inner skins of the cover panels and inspection doors consist of galvanized sheet steel. An intervening 45 mm thick slab of thermal and sound-attenuating insulation is sandwiched between the skins.

The cover panels can be dismantled from the unit.

The inspection doors have hinges and handles.

After fabrication the panels and inspection doors are given powder painted, min. 60 µm finish, RAL 7032. This leaves no open sectional areas and provides excellent corrosion resistance.



Carbon cartridges

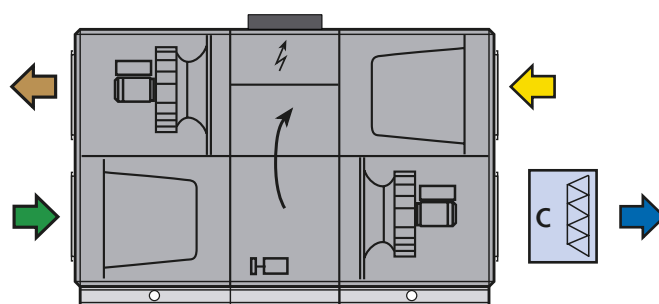

Installation

The TBFK carbon filter section has a connection frame for slip-clamp jointing and is designed for installation in the ductwork, see adjacent illustration.

Note that the TBFK carbon filter is available in six sizes and that the slip-clamp connection dimensions follow the connection dimensions of the GOLD air handling units.

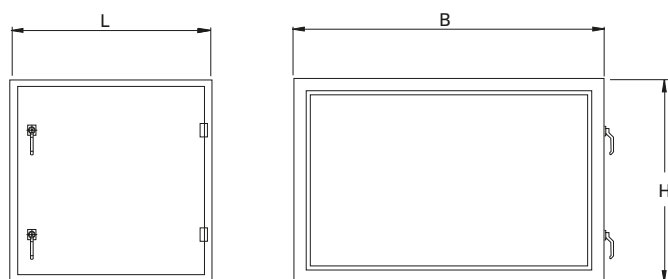

TBFK	Slip-clamp conn. width x height	B	H	L	kg without cartridges	Number of cartridges	kg with cartridges
017	850 x 350	1039	546	763	75	17	113
024	1100 x 500	1259	656	763	89	24	143
036	1300 x 600	1459	756	763	104	36	185
050	1600 x 700	1759	906	763	120	50	233
072	1800 x 800	1946	1026	763	144	72	307
098	2100 x 1000	2306	1206	763	172	98	393

Complements and Accessories

Roof hoods and exterior wall hoods

Common for all roof hoods

The hoods are made of aluminium-zinc plated sheet steel covered with a Plastisol (black) surface coating that conforms to Environmental Class C4.

The roof duct is made of galvanized sheet steel. It is lined inside with 50 mm thick insulation to Fire-resistance Class EI30, with a surface covering of type-approved synthetic woven fabric. Two angle brackets for

connection to the relevant roof having client-specified slope are included.

The hoods for the size 004-012 GOLD units have circular duct connection fitted with type-approved rubber ring seal for jointing to spiral ductwork.

The hoods for the size 014-040 GOLD units have rectangular duct connection for slip-clamp joint connection.

TBHA Outdoor air hood

Designed for the intake of outdoor air. The design of the hood obstructs snow and raindrop entrainment. The hood is hinged and has air intake wire screens on both sides. For GOLD sizes 004-040.

TBHB Exhaust air hood

Designed for the discharge of exhaust air. The hood can be opened on hinges and is equipped with air deflectors that effectively direct the exhaust air upward and give the air high discharge velocity. To achieve low pressure drop, the air deflectors are rounded off on both their long sides. The hoods are equipped with effective provision for drainage. For GOLD sizes 004-040.

TBHC Dual-purpose hood

The TBHC is a combination of TBHA outdoor air hood and TBHB exhaust air hood and is available for the size 004 - 012 GOLD units only.

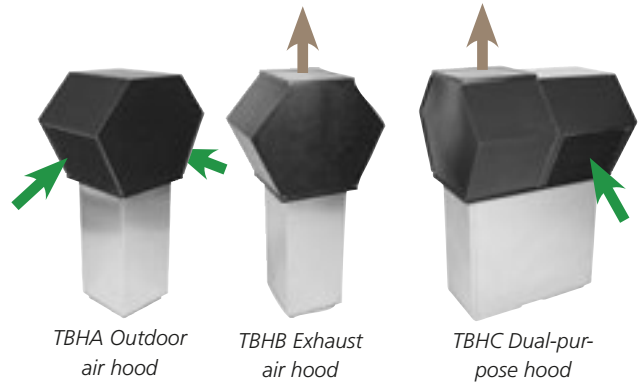

TBHA Outdoor air hood and TBHB Exhaust air hood

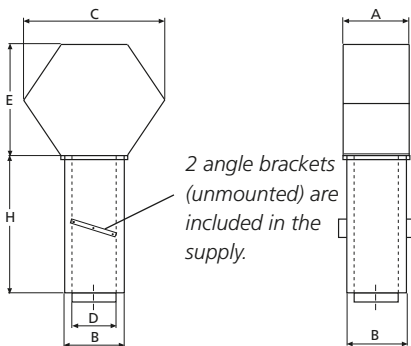

For GOLD	A	B	C	D	E	H	kg
004/005	500	400	850	Ø315	620	800	31
007/008	600	500	950	Ø400	620	800	44
011/012	820	700	1300	Ø500	850	1200	129
014/020	820	700	1300	600	850	1200	129
025 - 40	1120	1000	1700	900	1150	1200	148

TBHC Dual-purpose hood

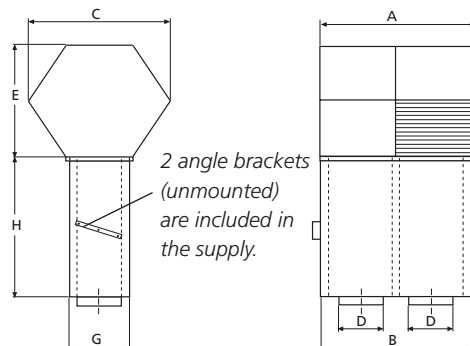

For GOLD	A	B	C	D	E	H	G	kg
004/005	1000	900	850	Ø315	620	800	400	70
007/008	1200	1100	950	Ø400	620	800	500	100
011/012	1600	1500	1300	Ø500	850	1200	700	290

Complements and Accessories

Roof hoods and exterior wall hoods

TBHE Exterior wall hood

The exterior wall hood is designed for the admission of outdoor air and the discharge of exhaust air. The exhaust air is horizontally discharged through a circular wire mesh grille at the front of the hood. Outdoor air is admitted through a wire mesh grille at the bottom of the hood.

This design effectively prevents short-circuit flow between the outdoor air/exhaust air. For GOLD sizes 004 - 012.

The TBHE exterior wall hoods are made of aluminium-zinc plated sheet steel covered with a Plastisol (light grey) surface coating that conforms to Environmental Class C4.

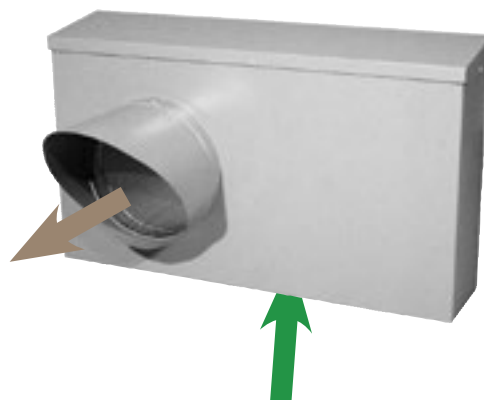

TBHE Exterior wall hood

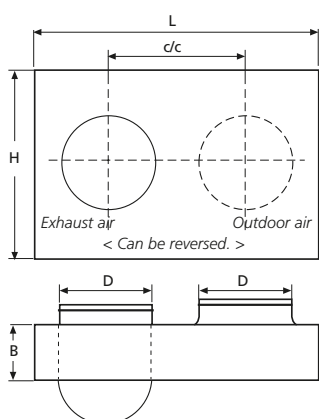

For GOLD	B	c/c	D	H	L	kg
004/005	200	420	Ø315	520	950	11
007/008	250	500	Ø400	580	1150	15
011/012	300	600	Ø500	750	1350	20

TCWP Component box

The TCWP component box is intended for the incorporation of components which must be protected from weather or mechanical damage. Typical components are valves, actuators, etc.

The component box consists of a GOLD-type casing. The component box is enclosed on all sides and has an inspection door that can be selected as a right or left-hinged door.

A roof is available as an accessory for outdoor installation.

The cutting of openings for e.g. pipes and electric cables, if required, must be done at the building site.

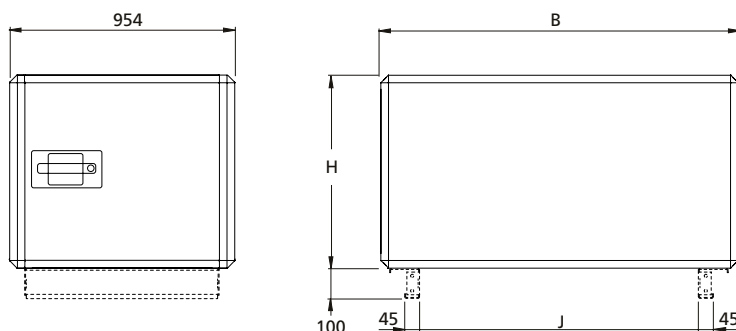

Size	B	H	J	kg
005	825	460	579	69
012	1199	648	953	102
030	1600	906	1354	143
040	1990	1080	1726	160

The base beams are optional extras for the size 005 (Standard on the other sizes).

Complements and accessories

Outdoor installation

GOLD units equipped with the roof, air intake section and exhaust air hood accessories can be installed outdoors. The roof cannot be used on GOLD air handling units with the fan outlet/inlet positioned on the top of the unit.

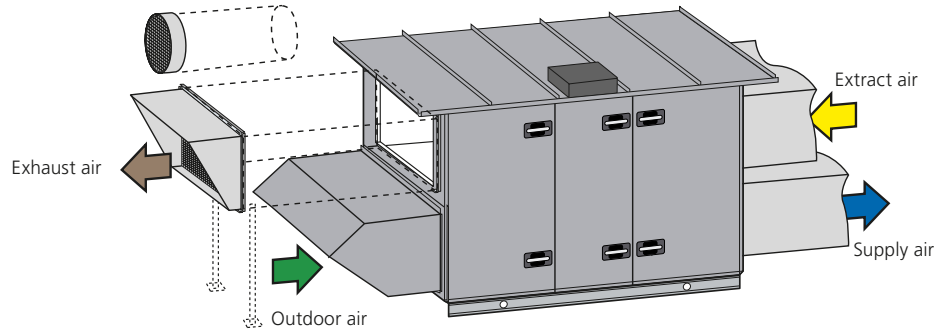

General

The GOLD air handling units, including optional unit sections and the COOL DX/DXS chiller can be installed outdoors. This presupposes that the roof, air intake section and exhaust air hood accessories are used. GOLD air handling units cannot be installed outdoors in applications that call for the fan outlet/inlet to be positioned on the top of the unit.

TBTB Roof

The roof is supplied in kit form, complete with the necessary assembly parts and sealing strips. The cover plates for all the door handles are included as standard.

Visible parts are made of galvanized sheet steel, painted in Swegon's grey metallic paint (nearest comparable RAL colour: 9007).

Dimensions

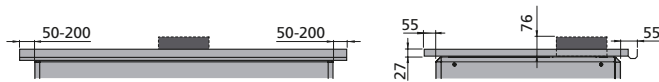

TBTF Intake air section with pre-filter (sizes 004-040)

The TBTF intake air section is made of galvanized sheet steel with visible parts painted in Swegon's grey metallic paint (nearest comparable RAL colour: 9007). The intake air section has a fixed grille and has a hole for drainage. The intake air section has rectangular connection dimensions and the air handling unit is supplied with full face end connection panel. The intake air section is equipped with slip-clamp connection. It is possible to order a filter and damper installed in the air intake section. The filter is an aluminium filter type that conforms to filter class G2, and also works as a water separator. Damper actuators can be ordered with spring return or with modulating function.

TBTA Intake air section (sizes 050-120)

The TBTA intake air section is made of aluminium-zinc plated sheet steel. The intake air section has a fixed louvre grille that effectively prevents raindrops from entering the duct and is equipped with holes for drainage. The intake air section has rectangular dimensions for all the sizes of GOLD and has space inside for an intake damper, if required. The intake air section has a flange with predrilled holes and is meant to be secured by means of screws to the end wall panel of the air handling unit.

TBTA Exhaust air hood

The TBTA exhaust air hood is made of aluminium-zinc plated sheet steel. The exhaust air hood is equipped with a protective screen. For air handling units with standard end connection frame, the exhaust air hoods are circular for unit sizes 004–012 and rectangular with slip-clamp connection for the other unit sizes. For air handling units with full face connection frames, the exhaust air hoods are always rectangular with slip-clamp connection. The exhaust air hood of the size 050-120 GOLD units is supplied in loose parts, the other components are assembled.

GOLD CX Cover hood

Cover hood that protects the pipework package on the GOLD CX installed outdoors (does not apply to sizes 100/120). Visible parts are made of galvanized sheet steel, painted in Swegon's grey metallic paint (nearest comparable RAL colour: 9007).

Duct Accessories

Select duct accessories housed in insulated casings if they are to be installed outdoors. They can be located outdoors, however the enclosure classes and permissible ambient temperatures of any actuators included must be taken into consideration. See the instructions for the corresponding accessory. If necessary, see to it that required protection is arranged. Water-tight protective bags for valve actuators are available as accessories. The protective bag has a zip fastener and is made of polyester with internal plastic coating.

Installation Tips

GOLD Air handling units should if possible be installed where the most favourable conditions exist from a weather point of view.

The ductwork for supply air and extract air must be insulated in accordance with local standards. If internally insulated ducts are used, the TBLZ-1-65 countersink kit should be used so that the measurement probe of the GOLD unit's supply air sensor will reach sufficiently far into the duct.

The hand-held micro terminal of the GOLD unit is sensitive to cold and must always be kept in a heated space. If required, use an extension cable or also an extension cable kit (see accessories for electrical and control equipment).

Swegon recommends moving the exhaust air hood a distance from the air handling unit by fitting a straight length of duct between them, especially if the exhaust air leaves the air handling unit from its lower level. This will prevent the risk of exhaust air shortcircuiting to the outdoor air and the risk of water entering the ventilation system.

Complements and Accessories

Mechanical equipment

GOLD Sizes 004/005 and 007/008

Stand

GOLD RX, rotary heat exchanger

GOLD SD, Supply air and extract air handling units

Specially designed stand, whose height makes it possible to arrange ducts under the air handling unit.

The stand is made of galvanized sheet steel profiled sections. The stand is supplied in assembly kit form. The long sides (A in the illustration) are used for horizontal installation and the shorter sides (B) are used for vertical installation.

Set of support legs

GOLD PX, counterflow heat exchanger

Specially designed set of legs, the height (745 mm, all sizes) of which makes it possible to arrange ducts under the air handling unit.

The set of legs consists of four legs made of galvanized sheet steel profiled sections. The legs are secured by means of bolts in the base beams under the air handling unit.

Base frame, (base beams) for the COOL DX 008

Specially designed stand with legs. Also used as base beams in combination with the GOLD PX

Cover holder

The cover holder facilitates the servicing and maintenance of vertically installed units. It consists of a mechanic stay with latch and is supplied in unmounted condition.

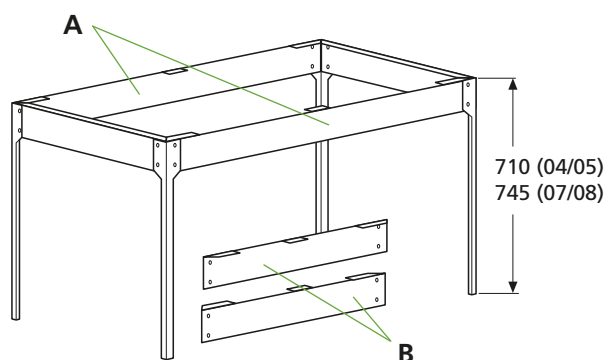

Stand for the GOLD RX/SD, Sizes 004/005 and 007/008.

GOLD - all sizes

Droplet eliminator

To prevent the condensate from being entrained by the air flow at velocities exceeding 3 m/s, the cooling coils in the casing can be equipped with droplet eliminators on the extract air side.

The material in the droplet eliminator is GLASdek, which is fire resistant and highly absorbent. The pressure drop across the droplet eliminator is low. The droplet eliminator is mounted on delivery.

The droplet eliminator can easily be inspected and cleaned.

Complements and Accessories

Mechanical equipment

GOLD - all sizes

Water trap

Water trap for drainage of the counterflow heat exchanger, coil heat exchanger and COOL DX chiller. Supplied with a set of connection fittings. The pipe from the water trap must be run without reduction in pipe dimension to a floor gully.

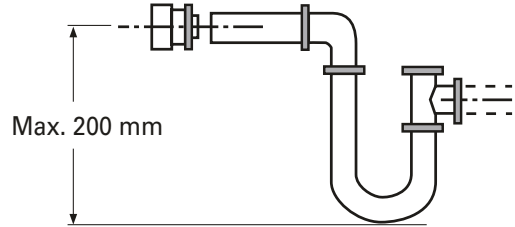

Support foot

Adjustable support foot for taking up unevenness or sloping of the floor. The support foot should be mounted on the base beam of the air handling unit.

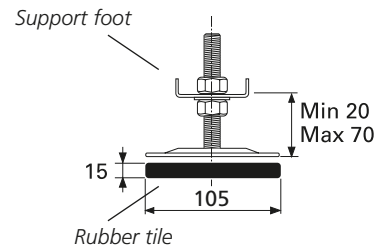

See the table for the number of support feet for a basic set-up (two filter/fan sections and one heat exchanger section) of GOLD.

Rubber tile

Designed to be glued under the support foot.

Slip-clamps

Set of slip clamps in appropriate lengths for one joint.

Metu connection

Type METU connection frame with set of bolts, 30 mm wide flange.

GOLD/SILVER C RX	Number of support feet
004 - 030	6
035 - 080	10

GOLD/SILVER C PX	Number of support feet
004 - 012	6
014 - 030	8
035 - 040	12

GOLD/SILVER CX	Number of support feet
035 - 080	12

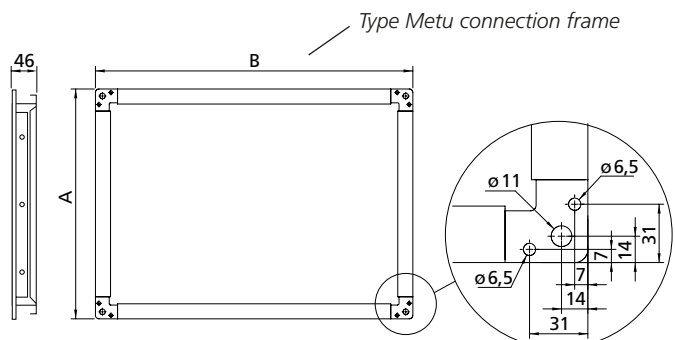

For GOLD	A	B	kg
014/020	458	1058	5
025/030	558	1258	5,5
035/040	658	1458	6,5
050/060	858	1658	8
070/080	1058	1858	9
100/120	1258	2458	12

Complements and accessories

Mechanical equipment

GOLD, all sizes

End connection panel, GOLD/COOL DX full face

End connection panel for transition between GOLD or COOL DX in full face version and uninsulated duct accessories or duct. Version as standard GOLD end connection panel, insulated and pre-painted in Swegon's grey metallic paint (nearest comparable RAL colour: 9007).

Duct accessory with duct connection size corresponding to that of the end connection panel's duct connection size can be ordered (does not apply to sizes 100/120). See section on Uninsulated duct accessories.

The end connection panels are supplied mounted on GOLD units and unmounted on the COOL DX units.

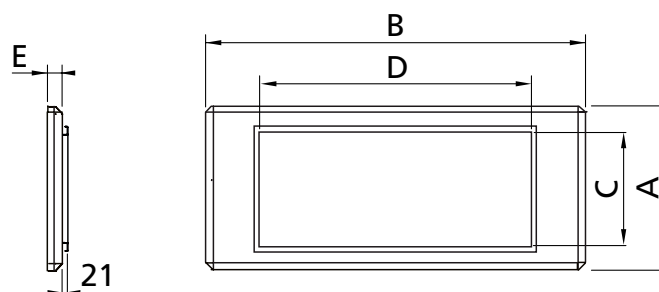

C x D correspond to the connection dimensions of the duct

For GOLD/COOL DX	A	B	C	D	E	kg
004/005	460	825	300	600	52	7
007/008	542,5	995	400	800	52	10
011/012	647,5	1199	400	1000	52	13
014/020	775,5	1400	500	1200	52	19
025/030	905,5	1600	600	1400	52	23
035/040	1079,5	1990	800	1600	52	34
050/060	1144	2318	1000	1800	52	34
070/080	1320	2637	1200	2400	52	40
100/120	1620	3340	1500	3100	56	59

GOLD RX/PX Top, sizes 025/030

Adapter, duct accessory

The adapter is used as a transition between the fan outlet on GOLD RX/PX Top size 025/030 and duct accessories.

Alu-zinc treated sheet steel.

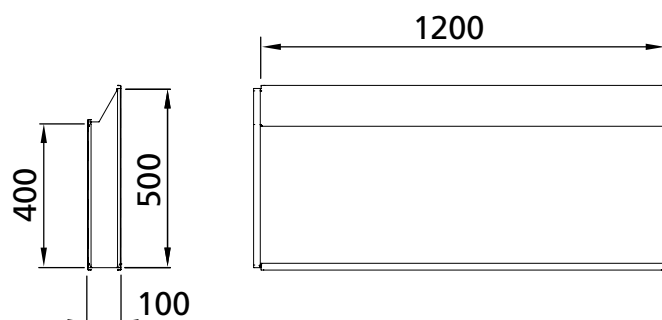

Weight: 5 kg

GOLD RX/PX Top, sizes 014-030

Adapter, duct accessory

The adapter is used as a transition between the air intake on GOLD RX/PX Top size 014-030 and duct accessories.

Alu-zinc treated sheet steel.

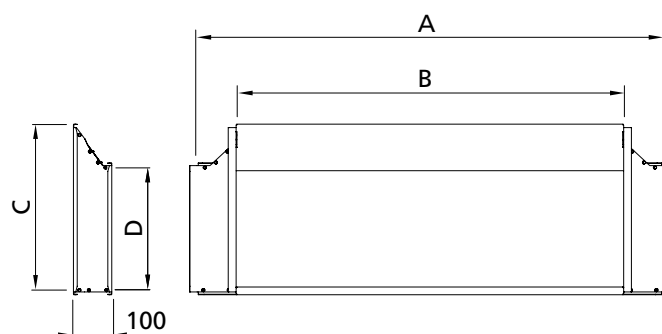

For GOLD	A	B	C	D	kg
014/020	1200	1000	400	300	4
025/030	1400	1200	500	300	5

Complements and Accessories

TBXZ Pipework Package

The pipework package is used for the GOLD SD with coil heat exchanger and the size 100/120 GOLD CX units. The floor stand for the pipework package is available as an accessory. With the floor stand, the height from floor level to the thermometers on the installed pipework package is approx. 1480 mm.

The following is included in the supply: The pipework package is supplied complete with insulated sheet-metal casing, pump, control valve with actuator, expansion vessel with safety valve and manometer as well as shut-off cocks, thermometers, filling valve and air purging valve. Wall mounting bracket.

Work to be carried out at the building site: Install the shunt, pump and expansion vessel at an appropriate place. Pipe route with insulated pipes to the air handling unit and between shunt, pump and expansion vessel. Electrical connection. Filling water mixed with glycol.

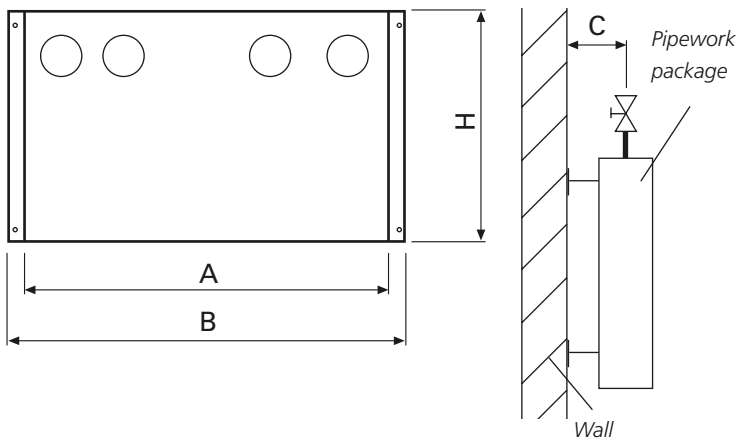

GOLD/SILVER C Sizes	TBXZ-42 Size	A	B	H	C
004/005	05	601	669	415	130
007/008	08	601	669	415	130
011/012	12	601	669	415	130
014/020	20	601	669	415	130
025/030	30	772	839	530	128
035/040	40	772	839	530	128
050/060	60	772	839	530	128
070/080	80	772	839	530	128
100/120	120	937	1003	640	141

Communication

Communication unit, TBLZ

Communication via TCP/IP, EIA 485 and EIA 232 as well as via internal web server is standard in the GOLD. The TBLZ extra communication unit is required for communication via LON FTT-10 - Lon Works. The communication unit must be connected to the communication port of the GOLD unit. Power can be supplied from appropriate terminal connections on the GOLD unit.

The scope available for communication is conditional on the software and its programming. The GOLD unit in itself provides potential for comprehensive communication of readings, settings and functions.

Modem

Analogue or GSM. Can be used when direct connection cannot be made to a network or communication system.

Several units can be connected to the same modem.



Complements and Accessories

Electrical and Control Equipment

Occupant detection sensor

Instead of using a timer for controlling the fans to operate in the high speed or low speed mode, TBLZ occupant detection sensors can carry out this control. As soon as the sensor registers the presence of an occupant in the room, it transmits a signal to the control unit to switch the unit to the high speed operating mode. When no occupant is registered in the room, the unit returns to the normal flow mode. Connect via appropriate terminal connections on the control circuit card.

Pressure transducer

For use in conjunction with the VAV pressure control function, when constant pressure must be kept in the ductwork. Also for use in conjunction with the heat exchanger defrosting function, when the pressure across the heat exchanger must be controlled. The connection cable is included. 1 – 15 m long cable can be selected. Connect via appropriate terminal connections on the control circuit card.

Air quality sensor

For use in conjunction with the demand-controlled VAV function, when the airflow of the air handling unit must be variably controlled by means of an air quality sensor. Available for duct or room. Connect via appropriate terminal connections on the control circuit card.

VOC sensor

For use in connection with Wise Apartment or demand control of the GOLD. To be mounted inside an air duct.

Wiring is to be done on the control circuit card's communication bus.

Room sensor, outdoor/room sensor

Used in conjunction with functions that require temperature readings from outdoors or from rooms. The sensor is designed for wall-mounting and is available for degree of protection IP 20 or IP 43. Connect via appropriate terminal connections on the control circuit card.

Internal duct temperature sensor

Used in connection with the extract air regulation function or as a temperature monitor/alarm for the GOLD RX. The sensor is supplied with the length of cable specified by the client in the purchase order, 1 – 10 metres.

Extract air duct, temperature sensor

This can be used in conjunction with the evaporative cooling and Xzone extract air regulation functions, for example. The sensor is supplied with a 7 metre long cable.

Timer

The ELQZ timer is used for overtime operation in conjunction with the external high speed and external low speed functions. For strap-on mounting.

Connect via appropriate terminal connections on the control circuit card.

Timer, electronic

The TBLZ electronic timer can be used for overtime operation in conjunction with the external high speed and external low speed functions. For strap-on mounting.

Connect communication cable leads to appropriate terminal connections on the control circuit card. Separate power supply

Push button

The ELQZ push button can be used for overtime operation in conjunction with the external high speed and external low speed functions. For strap-on mounting. Can be selected with or without indication. Connect via appropriate terminal connections on the control circuit card.

Extension cables

5 metres long for air heater, water and electric 8 m long for hand-held micro terminal, supply air temperature sensor, pressure sensor and IQlogic⁺.

Extension kit for pressure sensor or external temperature sensor

For lengthening the cable, 6 – 50 m.

IQnavigator hand-held micro terminal with WLAN

IQnavigator hand-held micro terminal with WLAN for wireless connection to the IQlogic control card. Net adapter for hand-held micro terminal

Strap-on sensor

Temperature sensor for mounting against the surface where readings are to be taken.

Fire and smoke protection

The fire and smoke protection function consists of three separate units:

- TBLZ cubicle
- TBLZ smoke detector
- ELQZ* damper actuator.

the cubicle contains the control unit and connections. the smoke detector stops the air handling unit and controls the damper actuators to close the dampers. An alarm is presented in the hand-held micro terminal of the GOLD air handling unit.

SD card

Multi-media circuit card for program transmissions and logging.

230/400V Transformer

For connecting the air handling unit to 230V mains power supply.

Transformer, 230/24 V AC

For connecting 24 V AC electrical components to 230 V mains voltage.

IQlogic⁺

The IQlogic⁺ functional module is used for extra functions for which the inputs and outputs are not included as standard in which the control unit of the GOLD air handling unit. 1 – 15 metre long connection cable

Temperature sensor, IQlogic⁺

Temperature sensor, for the IQlogic⁺ module

Humidity sensor, IQlogic⁺

Temperature sensor, for the IQlogic⁺ module for dehumidification and dew point control.

Complements and Accessories

Electrical and Control Equipment

IQlogic+ enclosure

Enclosure for the IQlogic+ module. Equipped with DIN rail. IP65. Space for 2 IQlogic+ medium-size modules. Outer dimensions: 266 x 200 x 105 mm.

Xzone Control box

Control box for controlling one extra temp. zone, max.

ReCO₂

Complete set of components for controlling the function for mixing. The pressure sensor and the IQlogic+ are included. Air quality sensor to be ordered separately. The outdoor air damper must be of modulating type.

Control of the air heater for preheating

Includes temperature sensor for installation in a duct and the IQlogic+ with a 0.25 metre long cable.

All Year Comfort

Electrical equipment cubicle for controlling the primary water circuit for cooling and /or heating. For climate beams, perimeter climate systems, etc.

