



## P200/P200

- linear steady state characteristics
- integrated hydraulic accumulator
- safe to run dry (liquid)
- self-priming up to 4 meters depth
- liquid fertiliser-proof (AHL/UAN)

Capacity at 5 bar:	2 x200 l/min
Nominal speed:	540 U/min
Operating time pressure:	max. 15 bar
Short-term pressure:	max. 20 bar
Speed range:	450-600 U/min
Spline shaft:	DIN 9611/ISO 500
Standard working diaphragms:	8 x NBR
Accumulator diaphragms:	2 x NBR
Inlet- $\phi$ suction side:	2 x AS50
Outlet- $\phi$ pressure side:	2 x AS30
Lubrication:	Oil bath
Weight:	49,6 kg
Material:	Cast aluminium, partially anodised, NBR seals, POM, stainless steel: 1.4305

### Options:

- Desmopan® diaphragms
- Hydraulic drive

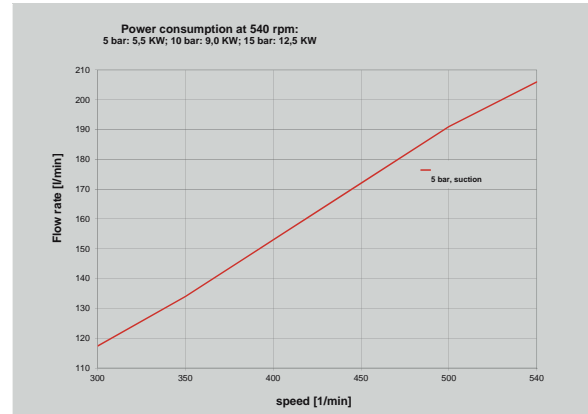

Pump options	
Article-No.	Type
83126	Piston diaphragm pump with bracket and pto protection with two separate P200/P200 out puts
More variations on request	
Recommended fittings inlet (AS2 and AS4)	
17330	Plug-in hose tail AS50/ø46/90° cpl
17157	Plug-in hose tail AS50/ø46 cpl
Recommended fittings outlet (AS1 and AS3)	
08337	Plug-in hose tail AS30/ø25/90° cpl
33793	Plug-in hose tail AS30/ø33/90° cpl
81119	Plug-in hose tail AS30/ø25 cpl
01399	Plug-in hose tail AS30/ø33 cpl

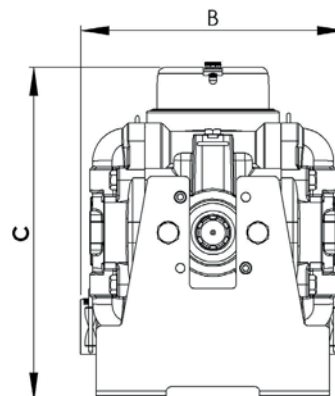
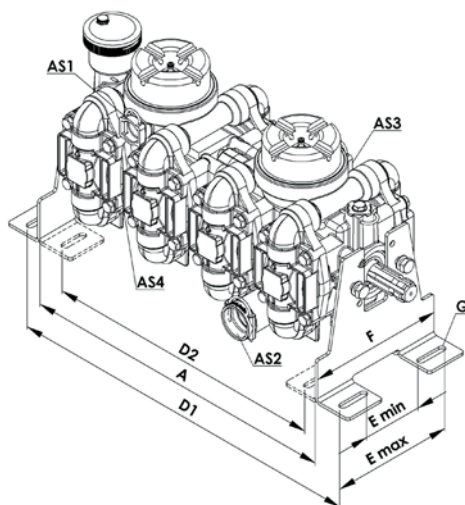

A	B	C
590	283	357
D1	D2	E <sub>Min</sub>
670	520	110
E <sub>Max</sub>	F	G
225	250	M12
Specified in mm		