

Minimising the risk of Legionnaires' disease



TM13: 2013



Minimising the risk of Legionnaires' disease

CIBSE TM13: 2013



The Chartered Institution of Building Services Engineers
222 Balham High Road, London SW12 9BS

The rights of publication or translation are reserved.

No part of this publication may be reproduced, stored in a retrieval system or transmitted in any form or by any means without the prior permission of the Institution.

© April 2013 (fourth edition) The Chartered Institution of Building Services Engineers London

Registered charity number 278104

ISBN 978-1-906846-33-6

This document is based on the best knowledge available at the time of publication. However no responsibility of any kind for any injury, death, loss, damage or delay however caused resulting from the use of these recommendations can be accepted by the Chartered Institution of Building Services Engineers, the authors or others involved in its publication. In adopting these recommendations for use each adopter by doing so agrees to accept full responsibility for any personal injury, death, loss, damage or delay arising out of or in connection with their use by or on behalf of such adopter irrespective of the cause or reason therefore and agrees to defend, indemnify and hold harmless the Chartered Institution of Building Services Engineers, the authors and others involved in their publication from any and all liability arising out of or in connection with such use as aforesaid and irrespective of any negligence on the part of those indemnified.

Project management, editing, layout, typesetting and printing by
The Lavenham Press Ltd., Lavenham, Suffolk CO10 9RN

Cover illustration: © Chepko Danil Vitalevich, sourced through Shutterstock.com

Note from the publisher

This publication is primarily intended to provide guidance to those responsible for the design, installation, commissioning, operation and maintenance of building services. It is not intended to be exhaustive or definitive and it will be necessary for users of the guidance given to exercise their own professional judgement when deciding whether to abide by or depart from it.

Any commercial products depicted or described within this publication are included for the purposes of illustration only and their inclusion does not constitute endorsement or recommendation by the Institution.

Foreword

These Technical Memoranda offer guidance on the appropriate design, installation, commissioning, operation and maintenance procedures necessary to minimise the risk of infection by *Legionella* from water systems within a building. Principles are highlighted, and practitioners in these fields are encouraged to apply them to their own particular building services applications.

While the emphasis is on engineering, it is important to recognise that the best engineering solutions can fail, and have failed, if their operation and implementation are not managed effectively. Some indications of how to implement effective management procedures are included.

It has been over 10 years since TM13 (CIBSE, 2002) was last reviewed. While some aspects of the guidance have changed significantly, in light of the legal, environmental and technological advancements that have occurred, advice in other areas has remained unchanged.

In the fields of water conservation and the environment in particular, new systems and services have been introduced and, no doubt, further developments will take place. It would be impossible therefore to list and categorise all potential sources of hazard in relation to *Legionella* and building services. What the authors have sought to do is to cover in detail the processes associated with the more commonly encountered or potentially higher risk systems and the principles that should be considered for the effective management of all other water systems in buildings.

The authors are also aware that specific industry and sector guidance is available and again, where appropriate, this has been referenced. This list is not exhaustive, however, and the information referenced has been chosen to best represent the intended audience of this publication. It is hoped that the appeal of the document and its usefulness will extend beyond this group, however.

Concerns about the control of *Legionella* are becoming an ever more significant public health issue internationally. This update provides a reference to aspects of requirements or guidance that exist outside the UK. While some of the governing principles for managing the risks may be different, many similar themes are evident; the processes described in this guidance will provide a valuable additional tool for supporting compliance beyond the UK.

TM13 Working Group

Greg Davies (Assurity Consulting) (Chairman)

Giles Green (Zeta Compliance Services Ltd)

John Lee (Leegionella Ltd)

Robert Macleod-Smith (RIMS Consulting)

John Newbold (HSE)

Martin Shouler (Arup)

Chris Wilding (Ashland Water Technologies)

Julian Williams (Tower Systems Ltd)

Sanaz Nazemi Agha (Secretary)

Acknowledgements

The Institution is grateful to Ian Fellingham (IF Associates Ltd), Mike Iddon (Piscean Analytical) and Paul McDermott (HSE) for kindly reviewing the draft prior to publication.

Cooling tower schematics in Section 4 by courtesy of Baltimore Aircoil International.

Editor

Alasdair Deas

Editorial Manager

Ken Butcher

CIBSE Technical Director

Hywel Davies

CIBSE Head of Knowledge

Nicolas Peake

Contents

1	Legionnaires' disease: background	1
1.1	Introduction	1
1.2	Risk of infection	3
1.3	Multiplication factors	3
1.4	Aerosol generation	3
1.5	Number of bacteria inhaled	4
1.6	Susceptibility of individuals	4
1.7	Determining the risks	4
2	Regulatory framework	5
2.1	UK legislation	6
2.2	UK codes of practice	6
2.3	Other sources of guidance	7
3	Risk management	7
3.1	Background	7
3.2	Design and specification	8
3.3	Commissioning	9
3.4	Operation and maintenance	9
3.5	Quality management	10
3.6	Microbiological testing	10
3.7	Record keeping	12
4	Evaporative cooling applications	12
4.1	Introduction	12
4.2	Design	14
4.3	Operation	20
4.4	Control	25
5	Hot and cold water services	26
5.1	Introduction	26
5.2	Cold water services systems	27
5.3	Hot water services (HWS) systems	29
5.4	Small-scale, non-recirculating HWS systems	34
5.5	Microbiological testing	35
5.6	Flushing	36
6	Spa pools, whirlpool spas and whirlpool baths	36
6.1	Introduction	36
6.2	System management	37

7	Other possible risk areas	39
7.1	Risk assessment	39
7.2	Scheme of control	40
8	Conclusions and further information	40
	References	41
	Standards	41
	Legislation	42
	Bibliography	42
	Appendix A1: Glossary	43
	Appendix A2: Emergency cleaning procedure for cooling towers and hot and cold water service systems	47
	Appendix A3: Guidance for suspected outbreaks of Legionnaires' disease	48
	Appendix A4: System checklists	49
	Appendix A5: International legislation, standards and sources of guidance	53
	Index	56

Minimising the risk of Legionnaires' disease

1 Legionnaires' disease: background

1.1 Introduction

Legionnaires' disease was first recognised in July 1976, when an outbreak occurred among delegates attending an American Legion convention in Philadelphia. The cause of the outbreak eluded scientists for several months but, in January 1977, the Centers for Disease Control and Prevention, Atlanta, reported the isolation of the causative agent, a bacterium that they named *Legionella pneumophila*. Diagnostic tests were developed and reviews of stored specimens in laboratories revealed earlier outbreaks of the disease and sporadic cases dating back to the 1940s. This showed that the infection was not new, but had escaped recognition because the causative organism does not grow on the conventional media used to culture bacteria in diagnostic laboratories.

Legionnaires' disease is an uncommon infection: in the decade between 2000 and 2009 an average of 385 (range 180–551) cases per annum in England and Wales were reported to the Health Protection Agency (www.hpa.org.uk). The disease is notifiable under the Health Protection (Notification) Regulations 2010 in England and Wales, and the Public Health (Notification of Infectious Diseases) (Scotland) Regulations 1988 (as amended). An occurrence in the workplace must be reported under the Reporting of Injuries, Diseases and Dangerous Occurrences Regulations 1995 (RIDDOR) (see Section 2). Approximately 50% of the cases identified in the UK are associated with travel, mostly abroad but also within the UK. It is probable that some cases of Legionnaires' disease are not detected or reported. Estimates of the actual number of cases vary but intensive studies of community-acquired pneumonia suggest that 2–3% are Legionnaires' disease (Anon, 1987; Lim *et al.*, 2001). With approximately 200,000 cases of pneumonia reported per annum (p.a.), this suggests that the real number may be as high as 4000–6000 cases p.a. Countries with best surveillance report a case incidence of approximately 20/million population p.a. (Joseph and Ricketts, 2010), suggesting that England and Wales should have $52 \times 20 = 1040$ cases p.a.

Legionnaires' disease is an illness characterised mainly by pneumonia. It begins quite abruptly with high fever, chills, headache and muscle pain. A dry cough soon develops, and many patients suffer difficulty with breathing. About one-third of patients also develop diarrhoea or vomiting, and about half become confused or delirious. The case fatality rate is about 12%, which is similar to that of most other types of pneumonia. Legionellae also cause a self-limiting influenza-like illness without pneumonia called Pontiac

fever, which does not result in fatalities, and those infected recover with no residual ill effects.

Any illness caused by *Legionella* is known under the generic term 'legionellosis'. Although previously healthy people may develop Legionnaires' disease, individuals who are particularly at risk include smokers, alcoholics and patients with cancer, diabetes and chronic respiratory or kidney disease. There is a distinctive age distribution, with those over 50 years of age being most commonly affected; children are affected only rarely. Men are at greater risk than women (3:1). Only a small proportion (usually less than 1%) of those exposed in outbreaks develop Legionnaires' disease. In contrast, in outbreaks of Pontiac fever almost all of those exposed develop disease and both sexes and all age groups are equally susceptible.

Legionnaires' disease may be treated effectively with appropriate antibiotics. The diagnosis of Legionnaires' disease can be fully established only by laboratory tests:

- the organism can be cultured from sputum, blood, bronchial washings or lung tissue
- antigens derived from *Legionella* may be detected in urine and
- blood tests that measure the presence in serum of specific antibodies produced by the body to combat infection may be used.

The enzyme-linked immunosorbent assay for the detection of *Legionella* antigens in urine is well validated, available commercially and currently the most common method of diagnosis. It is very specific and can provide a rapid, reliable diagnosis during the acute phase of the illness, often much earlier than can be achieved by serological analysis of the blood, which was previously the most common method of diagnosis. Tests for antibodies in serum can be used for diagnosis but it can take several weeks to obtain a result as successive blood samples at least two weeks apart are usually required. Consequently, this test has now been largely superseded by the urinary antigen test. Polymerase chain reaction (PCR) based methods which detect the presence of DNA (the genetic material) from *L. pneumophila* and *Legionella* species in clinical specimens are increasingly used for diagnosis. The most commonly used method for the detection of legionellae in environmental samples is culture but PCR-based methods are increasingly being applied.

L. pneumophila is one member of a large genus of bacteria. At least 50 other species of *Legionella* have been reported, and at least 15 serogroups of *L. pneumophila* have been described. *L. pneumophila* serogroup 1 is the organism most commonly responsible for Legionnaires' disease in the UK, but the other serogroups of this and at least 19 other species

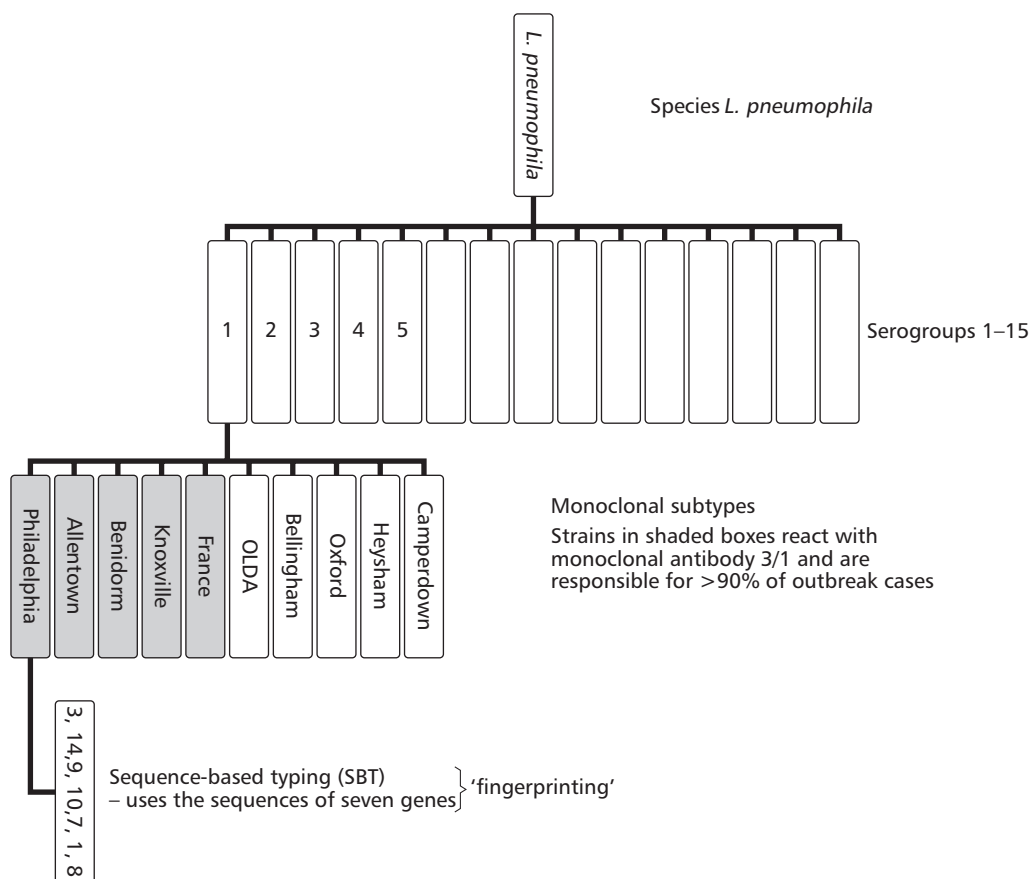

Figure 1 Divisions of *Legionella pneumophila*

have been found to cause disease in humans. *L. pneumophila* serogroup 1 can be further divided into various groups (see Figure 1).

Monoclonal antibody subgrouping has been developed for *L. pneumophila* serogroup 1 and studies have shown that one particular monoclonal antibody (3/1) distinguishes those strains most commonly associated with Legionnaires' disease (Helbig *et al.*, 1995). More discriminating molecular subtyping methods have been developed. One method, a consensus sequence-based typing (SBT) scheme based on the sequences of seven genes has been developed by collaboration between several European laboratories and is now widely used internationally (Gaia *et al.*, 2005; Ratzow *et al.*, 2007). This permits strains of clinical and environmental origin to be compared in the investigation of outbreaks and has largely superseded earlier typing methods. A database of types and their origins is held centrally and can be accessed by workers all over the world, enabling them to compare their isolates with those isolated in other laboratories and countries.

The genus *Legionella*, including *L. pneumophila* serogroup 1, is found in aquatic environments, both natural and artificial. They have been found in waters at temperatures from below 0 °C up to 60 °C. The organism is found most commonly in hot water services, particularly in storage calorifiers and evaporative cooling water systems that serve air conditioning plants. Systems that are corroded or contain debris or have evidence of organic fouling are more likely to harbour the organism. Other factors that favour growth of legionellae are stagnation of the system water content and an appropriate temperature: multiplication occurs between 20 °C and 45 °C with an optimum at between 32 °C and 42 °C.

Legionellae cannot grow by themselves but require the support of other organisms to enable them to multiply. They can grow inside protozoa, which not only support their growth but can also protect them from adverse environmental conditions. In addition, some other algae and bacteria have been shown to support their growth. Like most other aquatic organisms legionellae grow in association with other organisms on surfaces in a biofilm. A biofilm is a thin layer of micro-organisms, which may form slime on surfaces in contact with water. Such biofilms, sludge and scale can protect legionellae from temperatures and concentrations of biocide that would otherwise kill or inhibit these organisms if they were freely suspended in the water.

The association of legionellae with protozoa means that they may be protected from normal water treatment processes and enter the town drinking water supply system. In addition, legionellae are commonly encountered elsewhere in the environment. Thus, they may readily enter any manufactured water system and may eventually colonise it if conditions are appropriate.

The incubation period (the time between exposure to the organism and development of first symptoms) is normally between 2 and 10 days with a median of 6 to 7 days. Longer incubation periods of up to 16 days have been recorded for a small proportion of cases in some outbreaks and, extremely rarely, even longer (up to 22 days) for severely immunocompromised individuals. Person-to-person spread of the infection has not been documented.

The investigation of outbreaks of Legionnaires' disease has led to the identification of various sources of infection and routes of transmission. Sources of infection include:

- open and closed circuit cooling towers and evaporative condensers serving air conditioning and process cooling systems
- hot water and, more rarely, cold water services systems in large buildings such as hospitals and hotels (aerosols containing legionellae may be generated by running taps and showers and flushing toilets where the water is contaminated)
- spa pools (sometimes called whirlpool spas)
- fountains with a particularly fine spray in an enclosed space
- machine tool cutting coolant
- misting devices used for humidifying vegetables and meat
- untreated natural hot spring spa water used for inhalation, bathing or showering
- non-disposable nebulisers used for respiratory therapy
- industrial effluent treatment plants
- potting composts.

Many other water systems can contain legionellae (for example, rainwater harvesting, grey water and irrigation systems) and have the characteristics of incubation temperature and aerosol generation that suggest they could also cause infection.

Legionellosis is caused by inhalation of an aerosol of bacteria generated from water droplets (compost is a possible exception). Less commonly, it may also be caused by aspiration of *Legionella*-contaminated water (i.e. by contaminated water 'going down the wrong way' and entering the lungs).

Survival of the bacteria in an aerosol will depend on a number of factors, including ambient temperature, relative humidity, sunlight and transportation by wind.

1.2 Risk of infection

The risk of infection from a water system is dependent on a number of factors, including:

- the presence of one or more multiplication factors that allow legionellae to grow from low to high numbers; such factors include the water temperatures within the system, low flow rates and/or low turnover (stagnation) and the presence of certain materials, such as natural rubbers, some sealants and certain plastics, which may serve as a nutritional source within the system
- the possibility that aerosols may be formed and released within part of the water system
- the concentration of legionellae in the aerosol and the size of the aerosol particles; the risk increases the higher the concentration of bacteria and the smaller the size of particle (smaller particles are more dangerous because they can penetrate more deeply into the lung)
- the susceptibility to *Legionella* infection of the people exposed to the aerosol.

The duration of exposure may also have some influence.

It is worth considering these factors in a little more detail because they provide the clues to the prevention or control of the risk of infection.

1.3 Multiplication factors

The optimum temperature for multiplication of *L. pneumophila* in the laboratory is between 32 °C and 42 °C. The bacteria can survive at higher temperatures, but the survival time decreases from a few hours at 50 °C to a few minutes at 60 °C; at 70 °C the organism is killed virtually instantaneously. Below 37 °C the multiplication rate decreases, and it can be considered insignificant below 20 °C. The organisms can survive in a dormant state at much lower temperatures, and will return to active multiplication whenever more favourable temperatures occur. Legionellae have been found in water systems with a wide range of pH values.

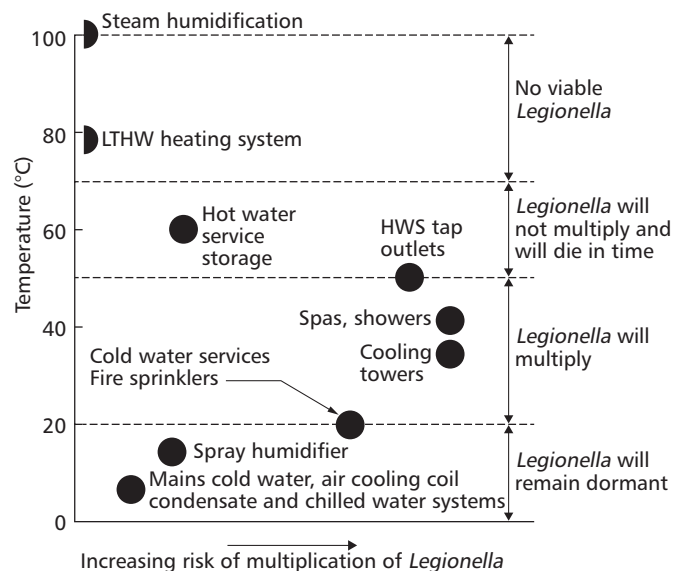

Figure 2 System design/operating temperatures and multiplication of *Legionella*

Typical design temperatures for water in building services are illustrated in Figure 2. Cooling towers and spas are designed to operate at temperatures that happen to be favourable for the growth of legionellae, and therefore such systems require regular biocidal treatment. Similarly, hot water services may contain deadlegs, blind ends and other stagnant zones that could hold water for long periods at the temperatures at which legionellae multiply. Cold water services may also reach temperatures likely to encourage multiplication of the bacteria (for example, unlagged pipework close to heat sources, limited service areas and increasing thermal performance of buildings).

1.4 Aerosol generation

Contaminated water presents a risk of actual infection when it is dispersed into the air as an aerosol. Small particles will remain airborne for long periods, and small droplets of 5 µm diameter or less penetrate deeply into the lung and cannot be expelled easily. However, larger droplets can

evaporate and become smaller ones, which still contain the initial number of organisms. The main mechanisms of producing an aerosol are by spraying water into an airstream, water streams breaking up or striking a surface, or by a bubble bursting on the water surface.

In both a cooling tower and an evaporative condenser, water is distributed over large areas of wetted surfaces to create intimate contact between air and water. This water continuously drains and collects into the pond at the base of the tower or condenser. Both the water distribution action and the draining flow create aerosols. The fans, which aid cooling, disseminate this aerosol (known as drift) over very large areas, and even when water is circulating with the fans switched off, the wind or convection draughts may force a significant amount of aerosol from the tower outlet. The exposure of building occupants to aerosols from cooling towers and evaporative condensers can be greatly increased if the aerosols are drawn into ventilation systems.

Water services are also capable of generating aerosols from the impact of tap water hitting wash basins, sinks or baths, and from spray taps, showers and flushing toilets.

In whirlpools and spas the agitation of the water is achieved by the combination of air jets and pulsating water flow. Splashing of the water and bursting of the air bubbles as they break through the water surface create an aerosol immediately above the water surface.

All devices that atomise water have the potential to create aerosols.

1.5 Number of bacteria inhaled

The actual dose of organisms required to infect a human is not clearly understood. In susceptible individuals it must be quite small — probably no more than a few tens of organisms. However, in healthy individuals it must be considerably greater, as the organisms are so common that everyone in the general population must be regularly exposed to them.

The risk increases with the number of bacteria inhaled and the susceptibility of the people exposed. Two factors determine the number of bacteria inhaled by an individual: the concentration of bacteria in the air and the duration of exposure to the contaminated air.

1.5.1 Concentration of bacteria in the air

This is dictated by both the concentration of bacteria in the water and the amount of contaminated water aerosols dispersed into a given air volume. The concentration in the air of aerosols containing live bacteria falls rapidly with an increase in distance from the water source.

For cooling towers risk of infection is greatest close to the source, but generally diminishes with distance as the aerosol droplets become dispersed. However, the degree of dispersion is dependent on local climatic conditions; in an exceptional case infection has been demonstrated up to 6 km away from a contaminated facility (Nguyen *et al.*, 2006).

For hot and cold water systems, running a tap vigorously or using a shower will also create an aerosol. Aerosols can also

be created by: bubbles rising through water and bursting, as in a spa pool; other systems where water strikes a surface, is ejected from spinning objects or ultrasonic atomisers.

1.5.2 The duration of exposure to contaminated air

The risk increases with the number of legionellae in the air, the respiratory rate of the individual and the length of time for which the person is exposed.

Exposure in a shower or bathroom is normally limited to a few minutes, while exposure in a spa is usually longer. It is probable that an infectious dose is not inhaled in a single breath but is accumulated over a few minutes. Exposure to airborne legionellae distributed within or outside a building from an evaporative cooling water system may take place whenever the tower is operating, which may be most of the day during the summer.

1.6 Susceptibility of individuals

Many people have been exposed to legionellae but their bodies' defence systems have responded to prevent illness. Although previously healthy people may develop Legionnaires' disease there are several factors that have been shown to increase susceptibility:

- increasing age, particularly above 50 years: children are rarely infected
- sex: males are three times more likely to be infected than females
- smoking, particularly heavy cigarette smoking
- existing respiratory disease, which makes the lungs more vulnerable to infection
- illness, such as cancer, diabetes, kidney disease or alcoholism, which weakens the natural defences
- treatment using renal dialysis or immunosuppressant drugs that inhibit the body's natural defences against infection.

1.7 Determining the risks

BS 8580:2010 provides guidance on how to undertake a *Legionella* risk assessment (see Section 3). This assessment of the risk needs to take into account the above factors and to apply some method of measurement to each, so as to produce a basis on which to judge whether there is a significant risk. A risk assessor who possesses an understanding of the particular water systems and of the ecology of *Legionella* should be selected. The name and title of the risk assessor should always be on the assessment, together with some indication of competence.

The assessment will sometimes indicate that the risk associated with certain sources is negligible, and will frequently identify conditions or practices that could be improved (perhaps reducing the risk to a negligible level). In many cases some risk will remain, necessitating a scheme of precautions or control measures.

1.7.1 Identifying all sources of risk

In order to ensure that all sources of risk have been included, a register of equipment needs to be compiled. Some of this information could be drawn from an asset register, based on drawings and inspection and gathered from on-site personnel with local knowledge.

1.7.2 Negligible risk sources

Some sources will immediately appear to constitute a minimal risk, but they require confirmation that risk conditions do not prevail. Typical sources in this group are:

- (a) direct mains cold water supplies where there is reasonable water throughput
- (b) cold water storage cisterns in which the temperature is consistently below 20 °C (this requires the temperature to be checked several times to establish whether there are any seasonal variations)
- (c) cold water distribution systems where there is reasonable water throughput and the temperature at all draw-offs reaches 20 °C within 2 minutes of use
- (d) hot water service systems where the temperature remains above 60 °C throughout the stored volume and the temperature at all draw-offs reaches 50 °C within 1 minute of use
- (e) steam systems
- (f) primary hot water heating systems
- (g) chilled water systems.

Note that the systems in (e) to (g) are closed systems, and therefore present no risk under normal operation. Some consideration should be given to the risks associated with all parts of the system under all reasonably foreseeable operating conditions. For example, a heating system may operate above the temperature range at which legionellae can survive and is fully enclosed. However:

- the feed and expansion cistern could easily contain warm water, as could any part of the system where there is no recirculation, in each case providing conditions suitable for legionellae to multiply
- maintenance work such as draining water for chemical testing or dosing, or even air venting radiators, could create contaminated aerosols.

Only once considerations such as these have been taken into account should a source be deemed to be of negligible risk.

1.7.3 Sources constituting a risk

Other water systems may also constitute a negligible risk, but most will have some risk associated with them. The degree of risk can be assessed by considering:

- the potential for *Legionella* to be introduced into the system
- the factors that affect its multiplication, such as temperature, stagnation and sources of nutrient, including the materials of construction

- the ability of the system (or part of it) to form and release aerosols
- the exposure to that aerosol (e.g. in the confines of a shower cubicle, in close proximity to a cooling tower, outside or via an open window or a ventilation system, working over a water spray, sitting in a spa bath) and the susceptibility of those exposed
- the extent of the exposure (the number of people affected and the duration of their exposure)
- the precautions in place to control the risk.

1.7.4 Recording and reviewing the risk assessment

The assessment of the risk of legionellosis must be recorded, whether it concludes that there is no significant risk, that the risk is controlled by virtue of existing design or operational techniques, or that further precautions are required.

The assessment needs to be reviewed whenever there are changes to:

- the use of the building or its management
- its water systems
- its mode of operation
- the environment in which the system operates (that may affect the risk).

Additionally, the assessment must be reviewed:

- if results of checks indicate that control is ineffective or the validity of the risk assessment is in doubt
- if a case of Legionnaires' disease is associated with a building and
- at regular intervals to confirm that it remains valid.

The review interval depends on the level of risk and could range from a few months for an open evaporative cooling system in a dirty environment up to two years for a simple hot and cold water services system.

1.7.5 Suitability of control measures

In most instances, the measures required for the control of *Legionella* in water systems, so far as is reasonably practicable, reflect good practice and are, generally, of modest cost. In some cases, however, interpretations of the requirements mean consultants, facilities management contractors and water treatment specialists may make recommendations which go beyond what is necessary to control the risk and for compliance (see Section 3).

Building operators should be aware of the local and national regulatory requirements relevant to their situation; aspects of these are highlighted in Section 2 and Appendix A5.

2 Regulatory framework

The regulatory framework in the UK covering *Legionella* is well-defined and encompasses primary as well as secondary legislation. Under this sits an Approved Code of Practice

and Guidance (ACoP) L8: *Legionnaires' disease — the control of legionella bacteria in water systems* (HSE, 2000), commonly referred to as 'L8', as well as a significant body of other guidance and advice.

Internationally, regulation around *Legionella* control varies in approach and requirements. Appendix A5 provides a reference list of some of the regulations, standards and guidance currently in place outside the UK.

2.1 UK legislation

The following paragraphs list the UK legislation directly applicable to managing the risk of *Legionella*.

The Health and Safety at Work etc. Act 1974 regulates all work activities (excepting domestic service) and places a general duty on employers:

- to ensure, so far as is reasonably practicable, the health, safety and welfare at work of employees
- to conduct their undertakings in such a way as to ensure, again so far as is practicable, that other persons who may be affected by the work are not exposed to risks to their health and safety.

It also places a duty on the occupiers of premises (for example, commercial landlords, managers of serviced office accommodation and maintenance contractors) towards people who use those premises for work.

Further duties under the Act cover articles (including plant and equipment) and substances used at work, again with a view to ensuring health and safety. General guidance on the requirements of the Health and Safety at Work etc. Act for building services engineers is outlined in CIBSE publication TM20 (CIBSE, 1995).

The Management of Health and Safety at Work Regulations 1999 provide a framework for controlling health and safety at work. As well as calling for risk assessments they also require employers to have in place adequate arrangements for the effective planning, organising, control, monitoring and review of their undertakings. This includes aspects such as:

- access to competent help in applying the provisions of health and safety law
- establishing procedures to be followed by any worker if situations presenting serious and imminent danger were to arise and
- co-operation and co-ordination in the workplace.

The Control of Substances Hazardous to Health Regulations 2002 (COSHH) provide a framework to control the risk from a range of hazardous substances, including microbiological contamination. The essential elements include:

- risk assessment
- the principles of prevention or control of exposure
- the use of control measures, where prevention is not practicable
- the preparation of procedures

- the maintenance, examination and testing of the control measures
- the provision of information, instruction and training for employees and
- where appropriate, the provision of health surveillance.

The Notification of Cooling Towers and Evaporative Condensers Regulations 1992 require the local authority to be formally notified of all such equipment when installed on premises and again on its removal.

The Reporting of Injuries, Diseases and Dangerous Occurrences Regulations 1995 (RIDDOR) define legionellosis as a reportable occupational disease.

Cases related to certain work activities are to be reported to the relevant enforcing body. For the manufacturing industry this is the Health and Safety Executive (HSE); for commercial premises or buildings where the public have access it is the environmental health department of the local authority.

The Corporate Manslaughter and Corporate Homicide Act 2007 came into force in April 2008. The Act means that companies and organisations can be found guilty of corporate manslaughter where fatality occurs following serious management failure as a result of a gross breach of the duty of care owed to the deceased person.

2.2 UK codes of practice

The HSE (formerly HSC) *Legionnaires' disease — the control of legionella bacteria in water systems Approved Code of Practice and Guidance L8* applies to plant and systems containing water that is likely to exceed 20 °C and which may present a risk through releasing a spray or aerosol during operation or when being maintained.

More specifically, L8 identifies cooling towers, evaporative condensers, hot water services, humidifiers and air washers that create a water spray above 20 °C and spa pools containing water that is deliberately agitated and recirculated. It advocates five simple steps to minimise or eliminate the risk of legionellosis:

- (a) identifying and assessing risk
- (b) devising measures to prevent/minimise risk
- (c) managing these measures
- (d) record keeping
- (e) detailing the responsibilities of those involved in the process as well as third parties (manufacturers, suppliers, installers, etc.).

L8 also gives detailed technical guidance on risk control. The techniques include avoidance of operational water temperatures between 20 °C and 50 °C, prevention of water stagnating, use of construction materials that are neither toxic nor provide nutrient for micro-organisms, minimising aerosols, cleanliness and the use of a water treatment programme.

BS 8580:2010: Water quality. Risk assessments for *Legionella* control. The standard is designed to give recommendations and guidance on assessing the risk of

legionellosis from artificial water systems. It is equally applicable to risk assessments being undertaken for the first time, or to review and audit where a previous assessment has been undertaken.

The Legionella Control Association (LCA) **Code of Conduct for Service Providers** (at www.legionellacontrol.org.uk) is a voluntary scheme developed by a working party drawn from the British Association for Chemical Specialities and the Water Management Society in close consultation with the Health and Safety Executive. It was originally published as: *The control of legionellosis: A recommended code of conduct for service providers* (WMS/BACS, 1999).

The scheme is for service providers involved in the supply of goods and services relating to the control of legionellae in water systems. The scheme is aimed at raising standards of service provided by member companies who register with the LCA and commit to its Code of Conduct. The LCA administers the scheme through an annual re-registration process and periodic audits of member companies. This Code of Conduct does not have any legal status, but will give guidance to users about the standard of service they can expect to receive from service providers who commit to abide by the Code. Information on the LCA and a guide to buying *Legionella* control services can be found on its website (see above).

2.3 Other sources of guidance

General advice on *Legionella* management for building operators in the UK is given in the HSE publication *Legionnaires' disease: A brief guide for dutyholders* (Leaflet INDG458) (HSE, 2012).

Healthcare premises may contain a high proportion of susceptible persons, and *The control of Legionella, hygiene, 'safe' hot water, cold water and drinking water systems (Part A and Part B)* (HTM 04-01) (Department of Health Estates and Facilities Division, 2006) provides more advice for these patient areas and ancillary buildings. The premises include in-patient and out-patient accommodation, such as hospitals, clinics, health centres, private hospitals, blood transfusion service premises, and nursing and mental homes as defined in the Registered Homes Act 1974.

For residential accommodation, specifically for nursing and residential care homes, further advice can be found in *Health and safety in care homes* (HSG220) (HSE, 2001).

There is no specific guidance for private dwellings, many of which fall outside the scope of the Health and Safety at Work etc. Act 1974. However, buildings with shared services or common parts that include the provision of water fall within its scope.

Concerns over climate change and usage of water and energy in buildings have seen the increased installation of new plant and equipment designed to help building owners, users and occupiers manage such aspects. Technologies including rainwater harvesting, wastewater recycling and solar heating, for example, are now incorporated in a range of commercial buildings. By definition, these water systems should be incorporated into risk assessments with any controls required to effectively manage the *Legionella* risk from these systems. Some of these systems can be controlled by temperature, others such as cooling towers and

evaporative condensers require a water treatment regime usually based on chemical conditioning.

Information on the travel-associated risks of *Legionella* is produced by the European Legionnaires' Disease Surveillance Network and can be obtained from their website (www.ecdc.europa.eu/en/activities/surveillance/eldsnet/pages/index.aspx).

The World Health Organization (WHO) provides general advice on *Legionella* on its website (www.who.int) together with more specific information in a book, *Legionella and the prevention of legionellosis* (WHO, 2007).

A further list of UK information is included in the references section and international regulations, standards and guidance in Appendix A5.

3 Risk management

3.1 Background

Good management is needed at all stages in the provision of building services and this requires several key elements, listed below, details of which should be recorded formally:

- a risk assessment
- clear guidelines on how the services are designed to work
- written operation and maintenance manuals
- a written scheme of *Legionella* control with clear indication of who will undertake the routine duties listed in the scheme
- appropriate staff training and experience with training records in the site log book
- authenticated (i.e. signed or initialled, either physically in hard copy or electronically, but always by a person who actually carried out or witnessed the work) recording of inspections, checks and measurements
- regular management checks.

The Duty Holder (employer, self-employed person or person in control of the premises) must understand that they have a statutory duty to ensure that its operation does not create a risk to the health, safety or welfare of anyone, either in their employment or not. The documented procedures in the operation manuals are designed to achieve this and should be followed.

A named individual with sufficient authority to make and implement decisions should be appointed by the Duty Holder to be responsible for water hygiene; this is the Responsible Person.

When the Duty Holder delegates responsibility to the Responsible Person, this does not reduce the obligation on the Duty Holder; indeed, it adds an obligation to ensure that the Responsible Person is competent and carries out the work correctly. Equally, when the Responsible Person appoints a contractor, advisor or risk assessor or employs an operative to perform tasks, this carries equivalent obligations.

Five aspects are reviewed below: design and specification, commissioning, operation and maintenance, quality management, and microbiological checks for *Legionella*.

Where possible, designers, contractors, commissioning specialists and maintenance companies should be accredited by a recognised quality assurance scheme.

The risk assessment is a reasoned appraisal of the likelihood of anyone being infected with *Legionella* from that system, so it needs to consider the following points.

- *Whether the system could be contaminated with legionellae.*

Trace contamination is always a possibility and can come from existing material in the system (it is almost impossible to prevent all microbiological growth and previous *Legionella*-negative analyses cannot be taken as any guarantee), the surroundings (dust or foreign bodies entering cold water tanks, for example) and even the water supply (although levels are usually below normal detection limits). If the water supply is from a source other than the mains, the likelihood of contamination may be considerably greater and this needs to be taken into account in the risk assessment.

- *Whether any such traces can multiply.*

This depends on the conditions that the legionellae encounter. Temperature is especially important, as is time. Nutrients, such as may be derived from sediment, corrosion, scale, airborne dust or fumes and from some materials of construction (certain rubbers and plastics, hemp and jointing pastes formulated with natural oils, certain coating and lining materials and many others) can also be significant as can the presence of organic or biological material. Water treatment may have a significant effect in inhibiting multiplication, but it must be proven to be effective and correctly applied.

- *Whether there is a mechanism for any legionellae to be released in an aerosol that could be inhaled.*

A closed vessel, such as a hot water service calorifier, would only generate an aerosol when the drain valve is opened or when work was being carried out inside (and even then, there might be relatively few fine droplets) whereas the shower it feeds generates a concentrated fine aerosol whenever it is used. An evaporative cooling tower will release aerosol; particularly where drift eliminators are badly fitted or have been removed.

- *Whether anyone is exposed to the aerosol and how much they are exposed.*

Opening the calorifier drain valve mentioned above would probably lead to exposure of only a very few seconds, while a user of the shower would be exposed to it for several minutes, typically within the confines of a small room or cubicle where the humidity would be high and supportive of survival. A cooling tower would run for longer than the shower and spread its aerosol more widely, but this would usually be rapidly diluted in dry air and often in sunlight (ultraviolet in sunlight and other toxic factors in air can kill *Legionella*).

- *Whether anyone exposed to the aerosol, which might contain legionellae, is susceptible to infection.*

There are several factors which make some people more susceptible to *Legionella* infection, these

include age, smoking, cancer, blood disease, diabetes, alcoholism, some medical treatments and pre-existing infections. There are, however, cases of *Legionella* infection in individuals in whom none of these factors was identified.

A further factor, which should be appraised, is how effectively the system is managed, as addressing anomalies and faults promptly and effectively reduces the opportunity for *Legionella* to multiply.

3.2 Design and specification

Building services engineers should guide clients in the preparation of an adequate and definitive brief for a new building or major refurbishment. Clear understanding of what will be provided is essential, particularly in the form of design operating conditions, commissioning records and operation and maintenance manuals. The design engineer must ensure that all of the documentation, including the operating manual and the maintenance instructions, are clearly written in a style that can be easily understood by non-technical readers. It should include:

- a description of how the design is intended to operate, together with
- the concept for the control and regulation of its operation.

The Responsible Person should keep a master copy of the documentation. The operating manual should also be available to the commissioning team so that it can be used to check that all is correct before handover.

In addition to ensuring that the design will provide suitable conditions for the health, safety and welfare of the building occupants, the designer also has a duty to carry out a risk assessment of the installation and maintenance procedures, highlighting any risks to personnel and detailing measures to minimise these (see the Construction (Design and Management) Regulations 2007 and BS 8580:2010).

The specifier should also pay particular attention to detailing requirements for the provision of adequate commissioning as well as the preparation of satisfactory operation and maintenance instruction manuals.

Check that the operation and maintenance manual contains the following up-to-date information for each water system:

- overview of the system
- intended mode of operation
- record drawings of the system as built rather than as designed
- schematic diagram of the total system as installed
- legionellosis risk assessment of the design
- schematic wiring diagram
- automatic control diagram
- pertinent manufacturer's information (i.e. not the manufacturer's catalogue)
- relevant statutory requirements

- location of access points and/or sample and flushing points
- commissioning records
- operating instructions, including water treatment and monitoring procedures
- maintenance instructions
- maintenance schedules, including tasks and related frequencies
- safety information and procedures (e.g. hidden features that may be hazardous, emergency isolation provisions)
- record sheet of changes to the original system.

3.3 Commissioning

A number of outbreaks have been associated with the start-up of systems from new or following a period out of use. It is essential that precautions be taken to control the risk during commissioning and start-up as well as during normal operation of the system. Commissioning and start-up procedures should include detailed precautions, particularly in respect of systems that have been left charged/filled with water for any length of time prior to the work being carried out.

Correct commissioning is vitally important for the satisfactory operation of the plant, and it should include the integrated operation of all parts of the system, including the controls, for a suitable 'proving' period. Insufficient time and resources are often allocated to this stage of the work. It is the designer's responsibility to specify fully and clearly the extent of the commissioning and the objectives that must be achieved, including details of any particular requirements and the permissible tolerances on performance parameters. Re-commissioning after a major design change or modification is equally important.

The project manager must ensure that the responsibility for commissioning is clearly attributed, and that adequate time is allocated. Pressure to compress this time scale must be resisted if there is the possibility of quality being compromised as a result. Commissioning should be carried out in a logical manner and in accordance with a method statement prepared by the commissioning specialist, utilising written procedures to ensure a consistent approach. Each particular installation will require its own plan but this should be based on the CIBSE Commissioning Codes: Code R (CIBSE, 2002b) and Code W (CIBSE, 2010), taking account of the particular design risk.

The period between commissioning and start-up is also critical and frequently difficult to control, as the plant is typically functional but with little or no operational load, so the controls incorporated in the design may not be effective. It is also usually a very busy stage of the project and there is likely to be a high turnover of personnel so particular attention is required to maintain continuity of control.

It is essential that a full report of all commissioning activities, including anecdotal comment by the commissioning technicians on plant performance, etc., is compiled for retention by the customer. The final details should form an integral part of the operation and

maintenance manual for that installation, which in turn should constitute part of the health and safety file. The availability of such records enables the Responsible Person to make periodic checks that the installation continues to operate as intended.

Formal arrangements should be made to check that commissioning has been completed to the standard specified. This may require an independent authority to witness selected aspects of commissioning, and to countersign the relevant record sheets.

3.4 Operation and maintenance

Operating staff should be provided with a manual containing clearly written operating procedures and instructions. Before they operate the equipment they should be trained to understand and implement these procedures. The instructions should include:

- a clear description of the system and its mode of operation
- accurate installation record drawings
- a schematic diagram of the total system, together with the wiring diagrams and automatic control schematics
- manufacturers' instructions and data for the proprietary components
- details of any relevant statutory requirements.

Details should also include the locations of access, sampling and flushing points and means of reaching them. Commissioning records should be readily available so that current operating conditions may be compared with those originally established.

Operating instructions should define those duties in which local judgement may be exercised and those that are mandatory. Modifications to the operating instructions should be recorded in the manual, together with a brief summary of the reasoning that led to the changes.

L8 (HSE, 2000) states that the Duty Holder must appoint a Responsible Person who should ensure that all responsibilities are clearly defined and formally allocated, that all demarcations are identified and that lines of communication are recognised not only within the services section but by all the other building occupants. The Responsible Person would normally be expected to be spokesperson for all aspects of plant operation, although formally nominated deputies are necessary to stand in in his or her absence.

Operating staff must be given adequate training on the particular plant, typically provided during the handover procedures, before they take over their responsibilities. The responsibilities and liabilities of each operative must also be defined in writing. The Responsible Person should be responsible for making all necessary arrangements for providing this training, for maintaining records of the training given to each individual, and for ensuring that all operatives are fully capable of carrying out their duties competently and effectively. He or she should also brief the operatives on how to communicate with the building occupants and others.

As part of their duties under the Management of Health and Safety at Work Regulations 1999 the Statutory Duty Holder (typically the employer or, in some cases, the building landlord) must carry out a risk assessment of the operation of the premises. Carrying out a risk assessment should not be confused with preparing a scheme of control; they are two different tasks. The risk assessment normally includes consideration of the suitability, application, management and effectiveness of the scheme of control and might make recommendations for changes to some of the control measures. One control measure, which is often omitted from the risk assessment, is consideration of the accuracy of the schematic diagram. The absence of a schematic diagram is a risk factor, which may be significant, and the Responsible Person might well commission the risk assessor to prepare one as an additional task.

As operation and maintenance staff become more familiar with the installation, and as their knowledge of its performance characteristics improves, they will be able to identify scope for improvement by fine-tuning of the plant. This may be carried out by the commissioning specialist or by the operation and maintenance staff themselves, but in either case, whenever this is done, the actions must be communicated to the Responsible Person, authorised and accurately recorded in the operation and maintenance manual.

Regular, signed recording by the operative of the critical factors in plant operation is important. A log book and pro formas should be provided for this purpose, and the records should be monitored regularly by the Responsible Person.

Regular planned maintenance is essential, and the records should also be monitored by the Responsible Person. Details should be specified in a comprehensive manual, readily available to the maintenance staff on site. In addition, provision should be made for prompt maintenance attention to faults reported by the operational staff. The Responsible Person should ensure that a formal procedure exists for occupants to register their complaints about the building services, and that a proper response is provided within an appropriate time.

All individuals involved in the control of *Legionella*, from the highest level of management to the operative, contractor or subcontractor, must be aware of the seriousness of their responsibility in implementing procedures to ensure the health, safety and well-being of the entire workforce and the neighbouring public. This applies particularly to the Duty Holder for the undertaking and the Responsible Person for controlling the risk. Responsible Persons must also understand the infection route for *Legionella* and appreciate the function of the water treatment programme. They also need to understand and countersign some of the more crucial items in the log book record sheet after each visit by the water treatment specialist. Both the laboratory test results and the routine inspection findings should be scrutinised by the Responsible Person as soon as they are available, and appropriate action taken where necessary.

These requirements apply equally whether the site is large or small, maintained by a directly employed labour force or by a contractor, by a resident operative or by a mobile operative making regular visits. Good

communication is especially difficult for a site with no resident engineering operative. A well-formatted system of records and manuals is even more important in these circumstances because the mobile operatives' site-specific knowledge may sometimes be limited.

3.5 Quality management

Quality management should include regular checks to demonstrate that the operation and maintenance procedures are achieving the desired aim. Organisations accredited to ISO 9001 will have a system for managing quality in place, although this may not cover these activities specifically. Preparation of operational record sheets in graphical form (to indicate operational trends clearly) or with built-in warning notes (showing clearly the actions to be taken in the event of deviations beyond defined limits from 'normal' conditions) should be encouraged. The name or other means of identification of the person undertaking the measurement or record should be provided. Such records help to make supervision by the Responsible Person easier and more effective.

In hot and cold water services systems the checks simply record the physical conditions of storage, storage time, temperature and its stability over the day (where this is considered to be of concern), and the draw-off temperature reached after a period of time at the taps. For circulating hot water systems it should also include return temperatures.

For cooling tower systems and evaporative condensers the composition of the make-up water and of the cooling water should be monitored routinely to ensure the continued effectiveness of the treatment programme. The frequency and extent of the checks will depend on the operating characteristics of the system, but the minimum is once a week to ensure that dosage and bleed rates are correct. Details of such procedures are provided in Section 4.

3.6 Microbiological testing

Sampling and analysis is not, and cannot be, a substitute for control; neither is any result, whether positive or negative, directly related to the risk to health, as discussed in Section 1. In building services systems, any *Legionella*-positive analysis should be given serious consideration as it usually indicates a failure of control, even though the direct risk may not be great.

3.6.1 Total bacterial numbers

An estimation of the total microbiological population in water is often undertaken to assess the level of control of microbial growth within a system. This is commonly done by estimating the viable bacterial count in the water measured as colony forming units per millilitre (cfu/ml). There are a variety of synonyms for this, including total viable count (TVC), plate count, aerobic colony count (ACC) and heterotrophic bacterial count. It is best determined by conventional microbiological culture techniques in a laboratory.

The bacterial colony count can also be determined by a simple, relatively crude, dip-slide method, which is commonly used for cooling waters because it is simple and can be undertaken on site. However, the method is more subjective and prone to errors and should not be used for testing water in hot and cold water systems.

A measure of total biological activity can also be achieved by determining the amount of adenosine triphosphate (ATP) in the water. The compound ATP is found in all living organisms and is used to generate energy for growth and movement. It is used by fireflies and other luminescent organisms to make light and this is the basis of commonly used tests for ATP. Many of these tests are simple, very rapid and can be undertaken in the field at the tap or cooling tower. Thus they can be used as a rapid measure of microbial activity in a system, but the results can be affected by other sources of ATP such as pollen.

Single or irregular tests of the bacterial count are often difficult to interpret and are of limited value. It is most useful to undertake these simple tests regularly, enabling a picture to be built up of what is normal and changes in the population to be detected. An unexpected rise could indicate a system going out of control or external contamination and an unexpected drop could also indicate a drop in temperature or an increase in biocide. Unfortunately, there is no direct correlation between the general bacterial population in a water system and the presence of legionellae.

3.6.2 Testing for *Legionella*

Testing for *Legionella* requires a skilled microbiological laboratory for assessment and interpretation. Periodic sampling (at least quarterly) for *Legionella* in cooling towers and spa pools is recommended to demonstrate that the biocidal control is effective for the organism. It is also commonly undertaken for hot and cold water systems, particularly in healthcare establishments where there are concentrations of susceptible individuals, and may also be valuable in cases of unproven techniques or in all systems in which control is proving difficult.

Sampling should be in accordance with BS 7592:2008. Samples should be taken when the biocide levels are at a minimum, be taken as near to the heat source as possible, have the biocide neutralised if possible at the time of sampling and be analysed as soon as practicable and within 24 hours of collection. If the biocide cannot be neutralised it is particularly important that the analysis take place as soon as possible after collection otherwise the biocide may continue to act causing an underestimate of the numbers of legionellae.

Samples should be analysed at a laboratory accredited for testing to BS EN ISO/IEC 17025:2005 by an appropriate national accreditation body such as the United Kingdom Accreditation Service (UKAS) in the UK. Legionellae and any other microbiological test performed in the laboratory should be included in its scope of accreditation. Testing for *Legionella* by culture should be done in accordance with ISO 11731:1998. The laboratory should be capable of a detection limit of less than or equal to 100 cfu *Legionella* per litre of sample.

Legionellae are commonly found in almost all natural water sources, so sampling of water systems and services

will often yield positive results. Failure to detect legionellae should not lead to the relaxation of control measures and monitoring. Neither should monitoring for the presence of legionellae in a cooling system be used as a substitute in any way for vigilance with control strategies and those measures identified in the risk assessment. If a *Legionella*-positive sample is found, more frequent samples may be required as part of the review of the system operation, in order to establish the source of the contamination and determine when the system is back under control.

Although culturing is currently required in outbreak investigation to enable the environmental isolates to be matched against those from the patients, the conventional methods for the detection of legionellae by culture detailed in ISO 11731:1998 are not ideally suited to the rapid monitoring of water systems or rapid investigation in outbreaks. There are complex reasons for this.

Inter-laboratory comparisons show that recoveries are often poor and in the range of 10–60% (Lee *et al.* 2002). Furthermore, the target of less than 100 cfu/l is near the limit of detection of most laboratories and below the level required for reliable quantification. This is often not appreciated by non-microbiologists, leading to over-interpretation of reported low counts or, alternatively, a failure to react to multiple low positive results, which may be significant and should be investigated.

Methods based on quantitative polymerase chain reaction (qPCR) offer an alternative to culture. They have been widely investigated and received appreciable commercial development and international validation. These methods detect target DNA sequences identified as specific to *L. pneumophila* and to the genus *Legionella*. Results can be obtained within a few hours of the collection of the sample. Any qPCR methods developed in the future should comply with ISO/TS 12869:2012. This standard was developed from the French AFNOR NF T90-471 (AFNOR, 2010) to which some commercially available assay kits have been certified. Water and environmental samples can contain materials that will inhibit the PCR and the efficiency of DNA extraction. Modern extraction methods have largely overcome these problems, and the methods should also include internal controls for each sample to detect inhibitors or poor extraction efficiency (Note: culture methods do not have such internal controls).

The results of qPCR are expressed for *Legionella* as genome units per litre (GU/l). One GU theoretically represents a single genome of a single cell. It might be expected that a single GU should equate to a colony forming unit but for many reasons in practice these terms are not equivalent or interchangeable. When qPCR for *Legionella* species has been compared with culture, more samples have been found to be positive by qPCR than culture and the number of GU per litre detected appreciably exceeds the cfu per litre; this is particularly true for cooling tower samples. There are a variety of reasons for this: the poor recovery of the culture method; the ability of PCR to detect DNA from dead as well as living cells; and the inability of many *Legionella* species that are widespread in the aquatic environment to be grown by the culture method. The genus *Legionella* is very large, containing over 50 recognised species, and there is increasing evidence from molecular population

studies of *Legionella* in the natural environment to confirm that there are many species occurring in nature that cannot be grown by the culture method but are detected by qPCR (Parthuisot *et al.*, 2010). There is much better correlation between qPCR and culture for *L. pneumophila* as the target sequence is much more specific. The difference between qPCR and culture for *L. pneumophila* can be explained by a combination of the poor recovery of the culture method and the ability of qPCR to detect dead cells.

An international trial compared the use of qPCR for *Legionella* with culture and aimed to establish guidelines for action and alert levels as determined by qPCR. This study confirmed the relatively large discrepancy between the results for *Legionella* species by qPCR and culture and the better correlation for *L. pneumophila*. In the absence of bactericidal activity in the water sample, such as residual biocides or temperatures above 50 °C, the difference was least (Lee *et al.*, 2011). In hot and cold water below 50 °C the differences reported by Lee *et al.* (2011) between qPCR and culture could be explained simply by the culture method only recovering 40–60% of the organisms (i.e. the poor overall recovery by culture alone). As has been found in other studies, the negative predictive value of qPCR for both *L. pneumophila* and *Legionella* species is high. If qPCR for *Legionella* species is negative then culture will also be negative. The study also illustrated it is possible to establish qPCR thresholds based on existing culture alert and action levels and to decide actions comparable to those based on culture.

A frequent criticism of qPCR-based methods is that they do not distinguish between living and dead cells. This remains true although modifications to the method are under investigation. Nonetheless, the detection of a high number of genome units of *L. pneumophila* is of public health significance. Supply water entering a building from public mains distributions rarely contains detectable numbers of *L. pneumophila* by culture or qPCR. Therefore detection of significant numbers of *L. pneumophila* dead or alive in a water system indicates that there has been amplification of *L. pneumophila* within the system. If these are dead at the point of sampling this, at best, indicates that control measures are limiting the release of viable legionellae, but should these be relaxed for any reason the system could immediately present a significant risk to health. In other situations it could indicate that there had been a recent addition of biocide to the system. A further explanation could be that due to poor sampling technique there was still active biocide in the sample at the time of collection and this was inadequately neutralised causing a false culture negative result. Thus qPCR offers a rapid, reproducible means of monitoring water for the presence of *L. pneumophila*. It can be used for routine monitoring for *L. pneumophila* and is particularly useful potentially for investigating outbreaks and failures in control. The application of qPCR can prevent unnecessary expenditure and quickly rule out negative sites, enabling better focusing of control measures.

3.7 Record keeping

The Responsible Person should ensure that appropriate plans of systems are recorded and retained and these should form permanent records. Records should include

details of the person responsible for conducting the risk assessment, the findings of the risk assessment, the scheme of control to reduce the risk overall and control it in operation, and details of the implementation of the scheme. Records should be retained for a period of five years. The records should also include:

- the results of any monitoring
- inspection and tests carried out, together with the dates undertaken
- chemical analysis of the water
- records of cleaning and disinfection work, including site-specific method statements and logs of visits by contractors, consultants and other personnel.

Staff details showing responsibilities for implementing the scheme and the training undertaken by staff are also required, as are details of other hazards, such as information on the chemicals used in water treatment.

4 Evaporative cooling applications

4.1 Introduction

All air conditioning systems provide cool air. This is generally obtained by passing air through a heat exchanger, which is chilled by a refrigerant or by refrigerated water. All refrigerant circuits need a means of rejecting the heat collected. For small duties it is often both economically expedient and practical to use air-cooled condensers or dry air coolers. Larger air-cooled coolers and condensers are now readily available. However, as the plant size increases it becomes increasingly more practical and economic to consider evaporative cooling. Evaporative cooling heat rejection saves energy as it achieves lower condenser water temperatures and there are operating cost, size, weight and fan power benefits compared to air-cooling. With the current drive to limit global warming it is important to note that air-cooled systems result in significantly greater power consumption than evaporative cooling at both the compressor and the fans.

The improved refrigerating performance of evaporative cooling assists the drive to reduce carbon emissions and satisfy the requirements of Part L of the UK Building Regulations.

Evaporative cooling applications, however, pose a significant risk because they operate at water temperatures at which legionellae can grow, nutrients for microbiological growth can be drawn into the evaporative cooling equipment and recirculating water during normal operation, and there is the potential for contaminated droplets to escape into the atmosphere.

All evaporative cooling applications require a risk assessment drawn up by a competent person and a written scheme for controlling the risk. The risk assessment needs to be kept up to date, should there be changes, and should be reviewed regardless at least every two years.

Rigorous control measures are needed to control the water quality within the system and minimise the release of water droplets and aerosols.

Given these control measures, together with good design, proper siting and regular maintenance and cleaning, evaporative cooling applications present little risk.

4.1.1 Types of evaporative cooling equipment

The three types of evaporative cooling equipment used in air conditioning are open circuit cooling towers, evaporative condensers and closed circuit cooling towers.

Open circuit cooling tower systems are the most commonly used. In such a system the cooling water collects heat from the refrigerant condenser, which is then pumped to a separate evaporative cooling tower, where the heat is rejected. This is achieved by distributing the water over a fill pack through which a fan system passes ambient air. This causes a small portion of the water to be evaporated. The latent heat of evaporation is taken from the remaining body of water, thus cooling it, and the heat is transferred into the airstream. The cooled water falls into the pond from where it is recirculated back to the condenser. Fresh make-up water is added to the system to compensate for the evaporation and windage losses and the bleed-off from the system. Warm, saturated air is discharged from the tower into the atmosphere.

An evaporative condenser uses the same principle but incorporates a heat exchange coil within the unit in which the refrigerant is directly condensed. The heat rejection is achieved by the evaporation of a portion of the water distributed over the coil by a secondary recirculating water system.

Closed circuit cooling towers work on the same principle as evaporative condensers. The condenser water is circulated through a closed loop heat exchange coil within the unit and the cooling effect is achieved by a secondary water system distributing water over the coil in the same way as an evaporative condenser. The benefit of a closed circuit cooling tower system is that the condenser water is in a sealed loop and is not exposed to contaminants in the atmosphere.

The volume of water in an evaporative condenser or closed circuit cooling tower is typically smaller than in an open circuit cooling tower system, which has an impact on the design and operation of the water treatment programme.

Each type of equipment is illustrated in more detail in Section 4.2.1.

These three types of evaporative cooling equipment are the ones to which the Notification of Cooling Towers and Evaporative Condensers Regulations 1992 apply.

The Regulations require any person who has control of premises (referred to in these Technical Memoranda as the Responsible Person) where there is a cooling tower or evaporative condenser to notify the local authority of:

- the address of the premises where the cooling tower(s) is/are situated
- the name, address and telephone number of a person who has, to any extent, control of the premises
- the number of cooling towers
- the location of the cooling towers on the premises.

The local authority must be advised of changes in these details (for example, removal of a cooling tower or it being permanently shut down) within one month of such changes taking place.

Some closed circuit cooling towers and evaporative condensers are designed so that they are also capable of operating dry without using the secondary water recirculating system in winter or when the load is low. These are known as hybrid units but remain classified as a cooling tower or evaporative condenser for the purposes of the Notification Regulations and need a full set of *Legionella* control measures when operating in evaporative mode. The heat exchange coil of a hybrid unit is normally finned to increase the performance in dry mode.

4.1.2 Adiabatic cooling systems

As an alternative to cooling towers or evaporative condensers, adiabatic cooler or condenser systems, in which the airstream can be pre-cooled by water when required, are becoming more commonly used. Adiabatic cooling equipment employs both evaporative and dry cooling processes. When operating in adiabatic mode there is a two-stage process. First, water is sprayed into the entering airstream or trickled over media which cools and humidifies the air. The cooler air then passes onto a conventional radiator-type cooler or condenser heat exchange coil, so increasing its thermal performance. Usually the pre-cooling mode is only operated intermittently and therefore may pose problems associated with water stagnation. There is a risk of aerosols from the water being sprayed into the airstream. If more water is fed than is evaporated, this may also lead to pooling of water around the equipment, which could result in microbiological proliferation. Each adiabatic cooler system must be considered on its individual merits as designs to minimise aerosols or water stagnation differ widely.

For the purposes of the Notification of Cooling Towers and Evaporative Condensers Regulations 1992, adiabatic systems are not regarded as an evaporative cooling application but a risk assessment should always be carried out and control measures put in place to match the level of risk.

4.1.3 Evaporative coolers

Evaporative air coolers which cool air through evaporation of water are not classified as cooling towers. They are normally small, packaged and sometimes mobile units which are used to cool parts of buildings, warehouses, etc. They may pose a *Legionella* risk depending on their design and operation and should be appropriately risk assessed.

4.2 Design

Good design plays an important role in ensuring the safety of evaporative cooling systems.

4.2.1 Cooling towers and evaporative condensers

The components of an open circuit cooling tower and alternative methods of water distribution are illustrated in Figures 3 and 4. Some other configurations of water tower are shown in Figure 5. Typical types of evaporative condensers and closed circuit cooling towers are shown in Figure 6. A hybrid closed circuit cooling tower that can operate either in dry mode (without water recirculation) or in wet evaporative mode is shown in Figure 7. Three different types of adiabatic coolers are shown as Figure 8.

Some notes on good practice, which apply to all evaporative cooling equipment, are shown as Table 1.

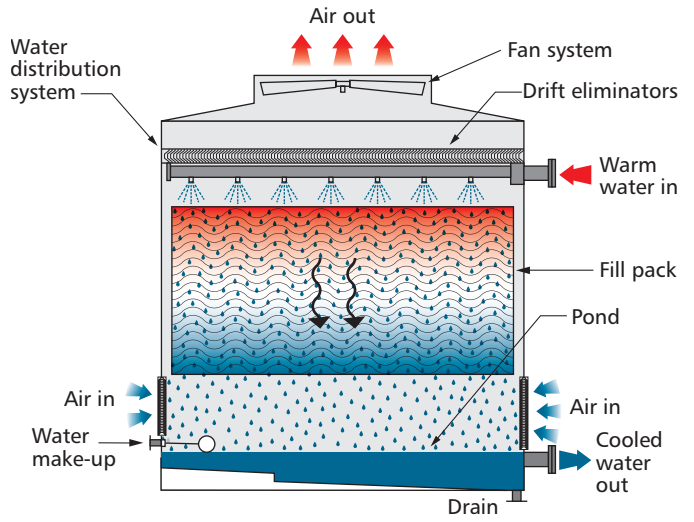

Figure 3 Components of an induced draught counter-flow cooling tower

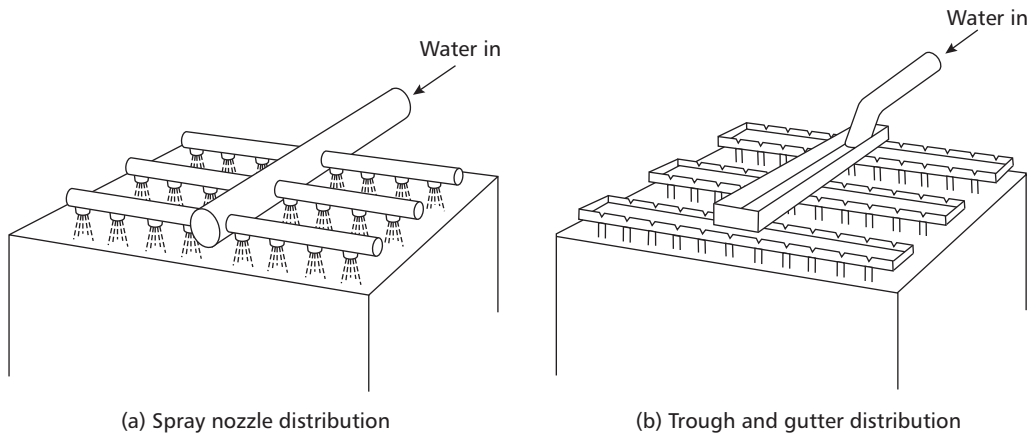

Figure 4 Details of two methods of water distribution used in cooling towers

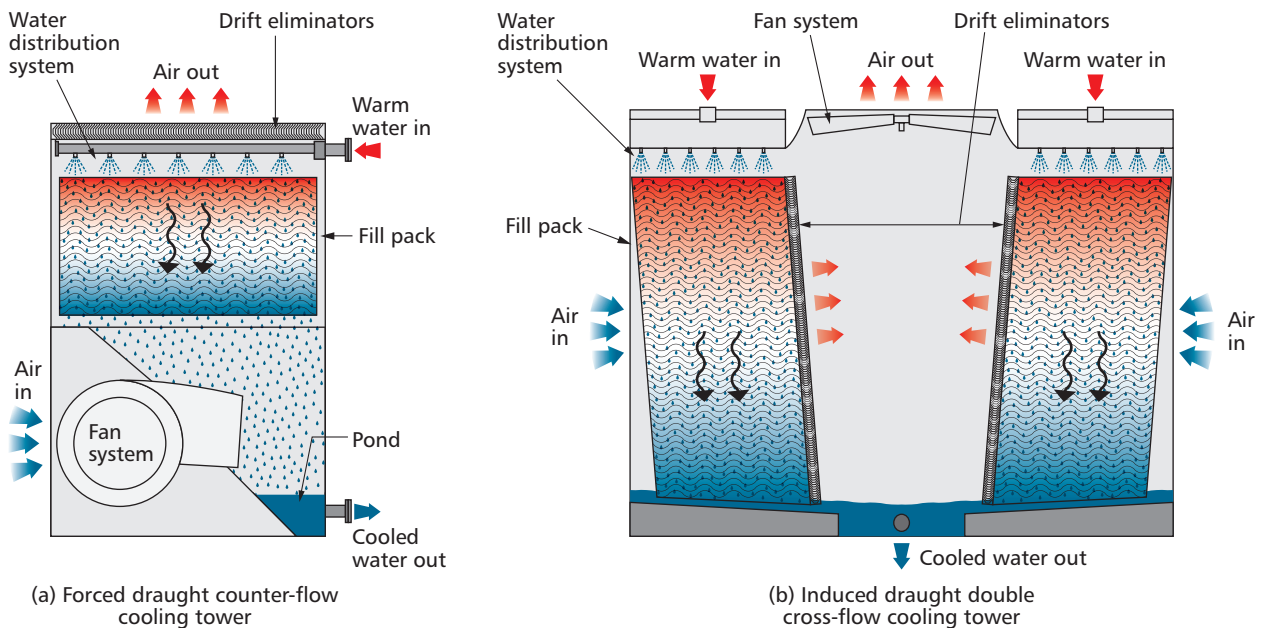

Figure 5 Other examples of open circuit cooling towers

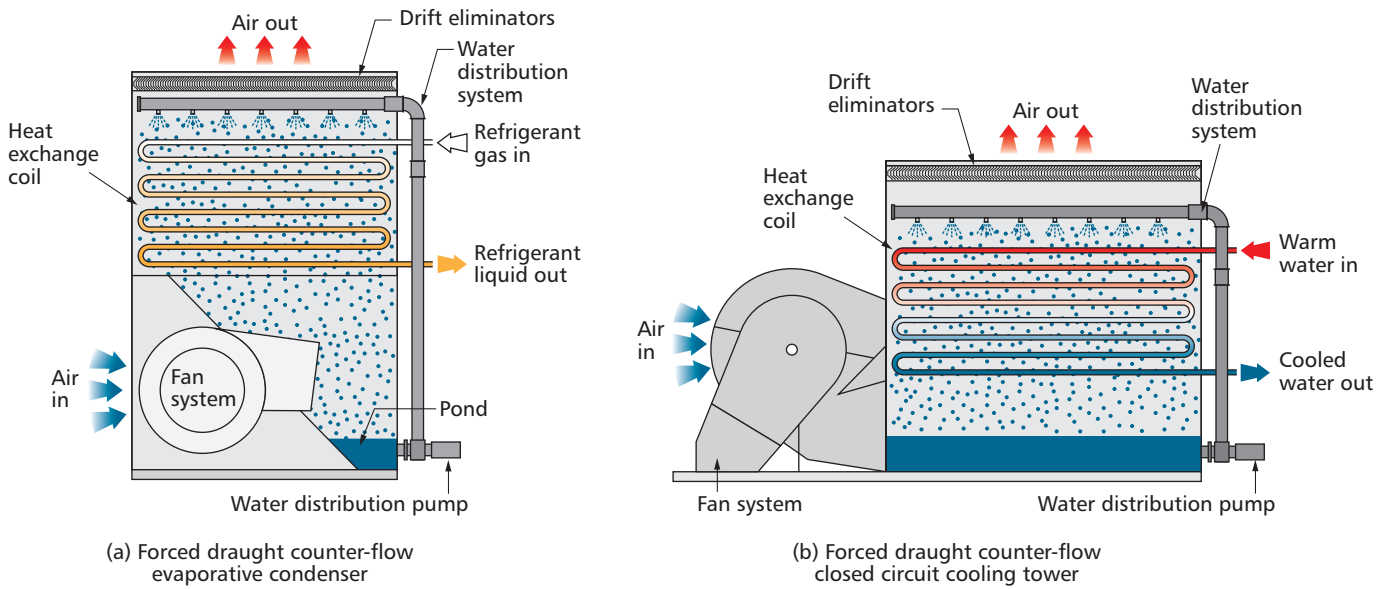

Figure 6 Evaporative condenser and closed circuit cooling tower

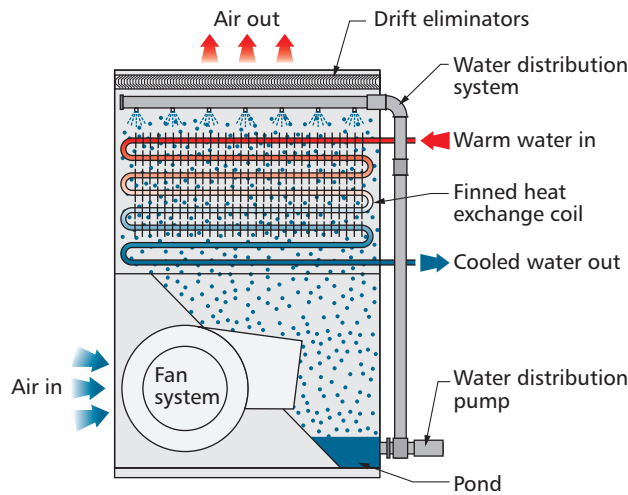

Figure 7 Forced draught counter-flow hybrid cooling tower with finned heat exchange coil

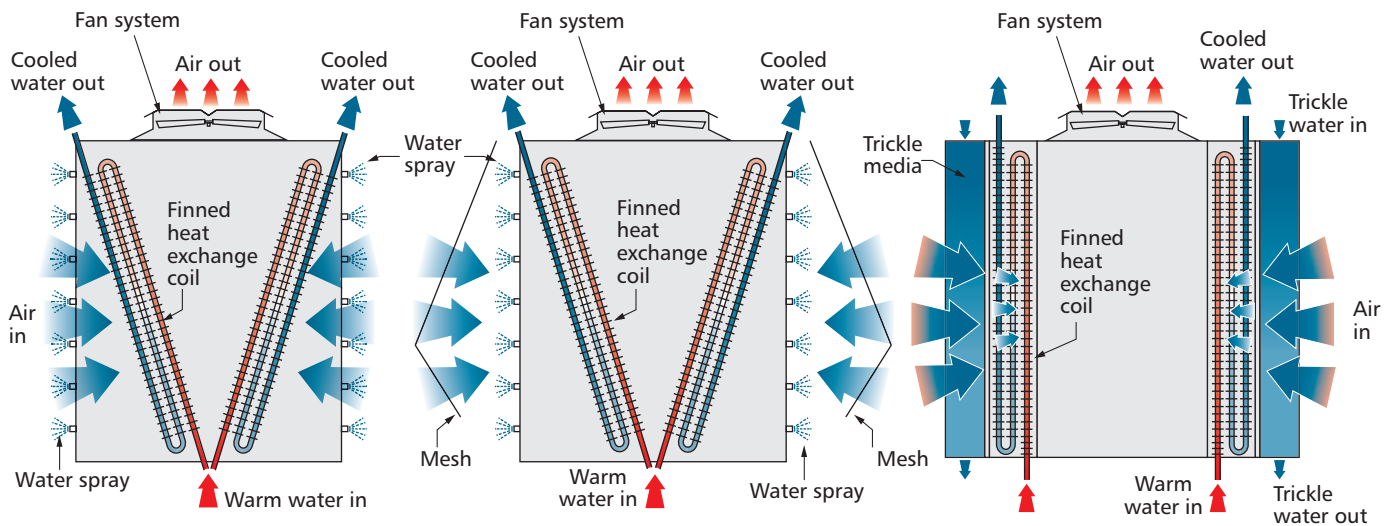

Figure 8 Three types of adiabatic coolers

Table 1 Cooling tower design good practice

1	Tower location to be considered carefully in relation to access for maintenance, fresh air intakes and flue outlets
2	High efficiency drift eliminators to be fitted to minimise carry-over under all operating conditions
3	Water distribution to be low pressure or gravity fed to minimise aerosol generation
4	Fill pack to be readily accessible and removable and easy to clean (consider use of spare pack to facilitate maintenance)
5	Design to offer full and easy access for inspection and maintenance
6	Wetted areas and pond to be shielded from direct sunlight
7	The water make-up inlet should be above both overflow and spillover level to avoid back-siphonage
8	Pond design to avoid hidden areas and sloped to promote accumulation of sludge and facilitate its removal
9	Pond drain to be of adequate size to enable the pond to be drained quickly
10	Air breaks to be provided for overflow and drain
11	Pipework system design, fittings and components to be appropriate to the actual volume flow rates required to meet design standards; arrangements for flushing and drainage to be adequate (50 mm diameter minimum); washers, jointing materials, etc. should not support microbial growth and should be selected from approved list. Deadlegs and blind ends should be avoided
12	System water volume to be marked on tower adjacent to the access hatch or other prominent location together with the tower reference details. Know and record water make-up rates. The water treatment programme to be comprehensive in all respects, and water quality to be monitored regularly. Testing for the presence of <i>Legionella</i> to be included as part of the monitoring, but care must be taken to ensure that it does not: (a) become a substitute for control of water condition (b) delay corrective action if the water condition is suspect (c) divert resources from maintaining good water quality
13	Standby towers and recirculating pumps to operate on a rota basis, e.g. daily on/off, or otherwise isolated and held dry
14	Automatic control operation to accord with design intent and be checked regularly
15	Strainers and screens to be provided and cleaned regularly
16	Internal surfaces to be smooth and easily cleanable
17	All components to be provided with manufacturers' instructions for operation and maintenance, including cleaning; instructions to be implemented
18	Appropriate sampling points to be provided

Distribution of the water in evaporative cooling equipment is achieved by a system of spray nozzles or self-draining troughs and gutters (see Figure 4). The water then flows through the fill pack or over the heat exchange coil and drains into the pond. The amount of water evaporated is small; under full load conditions approximately 1–1.5% of the recirculating water is evaporated on each pass for a typical 6 °C temperature difference across the tower.

With the spray nozzle arrangement, more droplets may be created, whereas gravity or trough and gutter will tend towards less atomisation of the water. Low water velocities associated with the trough and gutter arrangement can lead to the accumulation of sediment. Both arrangements require regular inspection and cleaning.

The airflow through the unit will tend to entrain the finer droplets and carry them through the tower. High efficiency drift eliminators are essential to minimise the discharge of droplets to atmosphere. These work by taking air through a complex system of baffles so that the water droplets impinge upon the walls while the air flows through smoothly. Drift from a cooling tower without eliminators would be excessive, and no tower should be operated without them. Modern eliminators, available for both new and existing towers, should be selected to reduce drift to below 0.01% of the water recirculation rate, although they tend to remove proportionally more of the larger droplet sizes. It is important to select drift eliminators that are effective at the air velocity prevailing when the cooling tower is in operation; when fitted and maintained they must be well seated and butt closely against one another with no gaps where the airstream can bypass the baffles. Damaged or fouled drift eliminators can lose their efficiency and should be replaced as soon as possible.

Algae on wetted surfaces (particularly those that drain into the cooling system water) provide nutrients and shelter for bacteria, and should be avoided. Shading wetted parts of towers that are susceptible to algal growth may help. Leaks from towers frequently support algae and should be sealed, but splash zones and the edges of wetted zones (such as on air intake louvres) and re-condensation zones (such as above top-mounted fans) will require frequent cleaning. Exhaust noise attenuators may trap large amounts of water, and old or damaged attenuation material should be replaced.

Frost protection heaters are normally provided in the pond and are controlled with a thermostat which is typically set to energise the heaters at approximately 4 °C water temperature.

Cooling tower construction materials should be corrosion resistant, with smooth, easy-to-clean surfaces. All non-metallic components, such as jointing and sealants, should be of a type known not to support microbiological growth. The WRAS *Water Fittings and Materials Directory* (www.wras.co.uk/directory/) provides identification of such materials. The overall construction of the tower should avoid static water zones and provide easy access for inspection, sampling, draining, cleaning and component removal. Large, robust access doors will permit easy accessibility.

4.2.2 System pipework

The amount of piping above the water level in the pond should be designed to minimise the risk of overflow from the pond when the tower is shut down. Piping layouts should be as simple as possible, with standby pumps

isolated or arranged so that cross-connections between them can be flushed out when the system is cleaned. Standby pumps and associated pipework should be put into use regularly to minimise water stagnation and the build-up of fouling, or be out of the water circuit but ready to be connected in the event of failure. Strainers should be positioned so that they can be properly cleaned during maintenance. Specialist coatings on fan and pond components will assist cleaning. Smooth, unobstructed surfaces in the base tank or pond also ease cleaning. The screen around the outlet from the pond and any anti-vortex plates must be easy to demount and to clean.

Balance pipes between adjoining duty towers and between duty and standby towers may not have any water flow during normal operation and could become deadlegs where water may stagnate. They should therefore be as short and straight as practicable, and easy to clean; such balance pipes must be capable of being fully drained and flushed.

Control valves in the piping must be properly sized to ensure that stable and satisfactory control is achieved; it is essential that the controls provided can match the requirements of the cooling tower throughout its operational mode. The control criteria need to be thoroughly understood by designers, contractors and operational staff. For cooling tower systems it is important that the hydraulics and water level control in the pond avoid overflowing from the tower or cavitation at the pump due to low water level. Balancing valves must be properly sized and correctly set, with the setting clearly identified on the valve and noted in the commissioning records included in the operating manual.

The total water volume of the cooling system including the pond, the condenser and its associated piping system should be measured and verified using independent techniques and clearly marked on the cooling tower as a basis for water treatment. The system total volume should also be recorded in the operating manual and the log book. When towers and evaporative condensers are located on anti-vibration mounts, the pipework at the tower must have flexible joints to allow for variations in height when the system is filled with water or is drained.

Techniques for measuring cooling system water volumes include the following:

- (a) metered filling from completely empty
- (b) metered draining
- (c) addition of a known quantity of a tracer agent (such as a lithium or potassium salt), thoroughly mixed, measurement of the resultant concentration, and calculation of the volume from the dilution (the bleed should be closed for this exercise)
- (d) measurement of the internal dimensions of the components of the system, including the pond, to waterline, pipework, distribution system, heat exchangers, water jackets, pumps, cross-connections, bypasses, sidestream filter or other particle separation units
- (e) estimate of the internal dimensions of the components of the system from a scale drawing.

Exact agreement between measurements made using two techniques is unlikely; however, the match should be within 15%.

Where a water make-up rate is quoted by the designer this should be based on the aggregate of evaporation, windage, drift loss and bleed (also referred to as blowdown) for the particular equipment used. A water meter on the feed supply to the tower is useful because it can accurately record the volume of make-up water being fed into the system, and is sometimes used to control the water treatment dosage rates. Adequate drainage facilities should be provided on all low points of the water distribution system, including the condenser. 'Calculation' will be by empirical means.

Duplex strainers may be used to facilitate maintenance. Sidestream filtration should be considered on any system susceptible to collecting particulate material, whether it is airborne (such as building or demolition dust) or contaminants from the water system itself.

It is very important to make provision for the legal and safe disposal of water drained off from the system.

Depending on the water treatment chemicals used, and their concentration, it would be prudent to consult the relevant water authority regarding the discharge of bleed or larger quantities of water to the drainage system.

4.2.3 Location

Cooling towers should be located well away from the air intakes for the building and windows that open, taking into account the recognised prevailing wind direction. Wind tunnel tests on models when the building is at the design stage can provide valuable assistance in determining the influence of the building geometry on local wind flow patterns. An aerosol will closely follow the wind pattern around the building. Designers should note that prevailing wind directions may change in winter and from morning to afternoon; wind roses indicating typical wind directions are available for some locations. Allowance should be made for this if the tower is operational throughout the year. Note that if the tower is operated at low loads with the fan(s) off then the action of falling water can induce downwards air flow and result in a low velocity drift cloud from the air intakes at low level.

A simplified impression of how air moves around a building is shown in Figure 9.

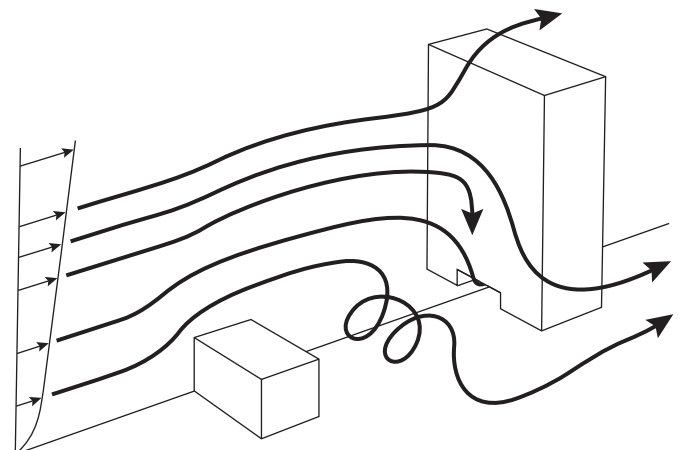

Figure 9 Airflow pattern in front of a tall building

4.2.4 Water treatment programme

In order to operate a cooling system correctly and safely, a suitable automatic treatment programme must be implemented at the start-up of the system and continuously maintained thereafter. To ensure efficient and safe operation and long system life, the water treatment programme must address five key elements:

- pre-treatment
- corrosion control
- scale control (deposition from dissolved solids)
- fouling control (deposition from suspended solids)
- microbiological control.

All these elements need to operate in conjunction with the design cycles of concentration (see below) and be able to work alongside each other to achieve an overall integrated programme. The programme will typically comprise dosing with chemicals, but non-chemical regimes may also be used.

Specific advice for particular water, environmental or operational conditions should be sought from a competent water treatment specialist, such as those working to the Legionella Control Association (LCA) Code of Conduct for Service Providers.

Different water treatment providers use different chemicals to achieve the same objective. Where providers change, it is important to obtain written assurance that any new chemicals are compatible, or that steps are taken to avoid adverse reactions. A review of the relevant section(s) of the risk assessment should also be undertaken and the assessment amended as required.

Successful management of the cooling system water depends on close collaboration between the system operator and the water treatment specialist. It also depends on an appropriate monitoring regime to ensure that the required water quality parameters are being controlled correctly, as well as to identify any changes in water chemistry that may impact upon the ability of the treatment regime to achieve its objectives.

A key control parameter when designing a water treatment programme for all cooling systems is cycles of concentration. This is needed because the system evaporates pure water when rejecting heat, leaving behind the impurities that were in the circulating water. As this process continues, the impurities become more and more concentrated, thus increasing the tendency of the water to become corrosive or scale-forming or to provide nutrients for microbiological growth. To limit these tendencies (and impurities) within the effective range of the scale and corrosion water treatment programme, a proportion of the impure water needs to be bled to waste (blowdown) and replaced by fresh make-up water. This is known as controlling the cycles of concentration and can be measured by the ratio of concentrations of a given ion, such as chlorides, in the make-up water versus the same ion in the system water. With automatic systems it is often the conductivity and hence the total dissolved solids that is measured to determine the concentration levels in the system.

A balance needs to be achieved between bleeding too much water, which adds unnecessary cost by way of more water usage and higher chemical dosage, and bleeding too little, which risks experiencing the problems described above.

Figure 10 illustrates this relationship. The water treatment provider will determine the ideal cycles that can be operated within the cooling system and this will typically be in the range of three to six cycles. Below three cycles equates to high water and chemical usage while at above six cycles incremental water and chemical savings are small.

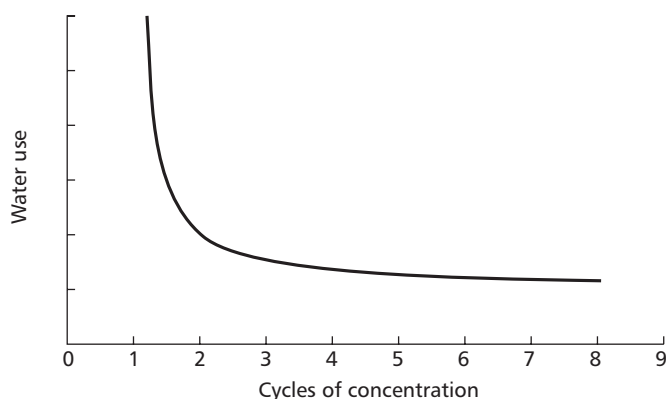

Figure 10 Relationship between cycles of concentration and water usage

Where the heat rejection load of a cooling system is steady, it may be possible to maintain control over the water quality by bleeding at a constant rate, either continuously or intermittently, on a time-controlled automatic bleed. Most systems, however, operate on demand, and the bleed requirements will vary widely over time, so to allow for this the bleed should be governed according to the demand of the system. Suitable measures by which to govern bleed include the electrical conductivity of the recirculating water or a timed period of bleed after the consumption of a predetermined volume of make-up water.

The bleed valve and conductivity electrodes must be readily accessible for cleaning, checking and calibrating, and for any other maintenance work.

It is common for the bleed to be suspended for a period of several hours following the addition of intermittently dosed biocides to allow time for these to disperse throughout the system and to achieve the contact time necessary to be effective.

Pre-treatment

A successful water treatment regime will often require conditioning of the supply water prior to it entering the cooling system itself, even when the supply is mains water. Depending on the source of the supply water, especially if it is hard or not mains quality, pre-treatment can include base exchange softening, pH control, filtration or microbiological treatment. Exact requirements will depend on the quality of the water entering the system or the design requirements of the cooling system itself.

Pre-treatment can often have a direct effect on each of the other four elements of the treatment programme and offers the opportunity to remove a potential problem before the water enters the system, rather than trying to control it once it is there. Pre-treatment can also generally achieve savings in the cost of treatment chemicals used.

Corrosion control

Components of an evaporative cooling water system are likely to be susceptible to corrosive attack by the recirculating

water if left untreated. The most vulnerable are metals in general, and carbon steel in particular.

Corrosion can occur as the result of any of several mechanisms, and may be accelerated by the presence of porous deposits such as scale, sediment or pre-existing corrosion products. Some chemical treatments form a coating over surfaces, and inadequate treatment can lead to local breaks in this coating, creating sites that are all the more vulnerable to the corrosive effects of the system water. It is common practice to apply a higher concentration of additives at the start of the treatment programme (for example, when first put into service or after cleaning and disinfecting) to passivate the surfaces. Many proprietary corrosion inhibitor formulations contain several components to protect the range of metals typically found in cooling tower systems.

It is usual with conventional corrosion treatment programmes to dose with chemical additives to maintain a constant concentration in the recirculating water. It is also important to differentiate between corrosion (chemical attack) and erosion (physical attack by water or particulate material). Chemical treatment cannot prevent erosion, but correct system design and water flow rate, as well as consideration of fouling control (see below), can.

Scale control

A means of controlling scale caused by mineral salt deposition is generally necessary to ensure that the system operates efficiently and that heat exchange and water flow are not impeded due to the formation and deposition of scale. In some locations the make-up water will be naturally soft enough for this not to be a critical parameter, but in most cases some form of treatment will be required. Treatments for water hardness control include pre-treatment, such as base exchange softening, and system chemical treatments that discourage crystal formation on surfaces within the system and instead hold fine solids in suspension. Examples are complexing agents (known as chelants) and pH control with acid, which reduces the tendency of the water to deposit the scale crystals. It is common now for both the corrosion control and scale control to be dosed as a single chemical formulation.

Pre-treatment that fully softens the make-up water increases its corrosive tendency and blending the fully softened water with some untreated supply is recommended to reduce this tendency. When selecting chemicals, care should be taken to ensure that the alteration of the water chemistry by softening does not create a corrosion problem as a consequence.

Fouling control

While dissolved solids can cause scale, suspended solids can cause fouling when they adhere to surfaces or settle out within the system. Suspended solids can also cause erosion of pipework and other materials in the system. There are many sources of suspended solids and these can principally be divided into particulate matter that enters the cooling system in the make-up water or from the cooling system itself (such as silt, corrosion debris, etc.) or material that is drawn into the recirculating water by the action of the fans (such as dust, pollen, insects, etc.).

The treatment for fouling will be partly dictated by the source of the material, but is typically a mechanical solution

in conjunction with a dispersant-type chemical treatment. Options for mechanical fouling control include full flow or sidestream filtration of the cooling water within the system. Filtration can play an important role in keeping the system water clean and reducing the amount of physical cleaning required. Dispersant chemicals help to prevent particulate matter adhering to surfaces as well as increasing penetration into existing accumulations of material. Generally they help to keep wetted surfaces cleaner.

Microbiological control

If the first four key elements of the water treatment programme are being addressed, i.e. the hardness controlled, corrosion inhibited, bleed maintained and particulate contamination minimised, then there should not be any barrier to effective microbiological treatment and thus avoiding the risk of *Legionella* proliferation. If any of the first four elements of the treatment programme are inadequate, the effectiveness of the biological treatment may be impaired. In addition to the treatment programme, the cooling water system must be kept clean with periodic cleaning of the cooling tower as described in Section 4.3.7.

Microbiological control can be achieved by continuous or intermittent chemical addition or by a non-chemical means. However, any programme needs to be supported by evidence of proven effectiveness in controlling *Legionella* in cooling water systems under a range of working conditions.

Automatic continuous chemical addition is the usual strategy when using oxidising biocides such as chlorine, bromine, chlorine dioxide or ozone. Dosing needs to be carefully controlled with specific sensing techniques to govern the addition of the oxidising biocide in order to maintain the concentration at an effective level throughout the system without overdosing, which can cause corrosion. It is important to remember that biocide concentration in the system alone is not a measure of the actual microbiological levels and the dosage rate may need to be adjusted depending on the microbiological results obtained. In the case of bromine or chlorine dosing, the biocidal effect is pH-dependent, where the pH of the water affects the actual percentage of effective biocide in the system, and a correction must be incorporated into the control levels to account for this (see Figure 11 and Section 3.4.7).

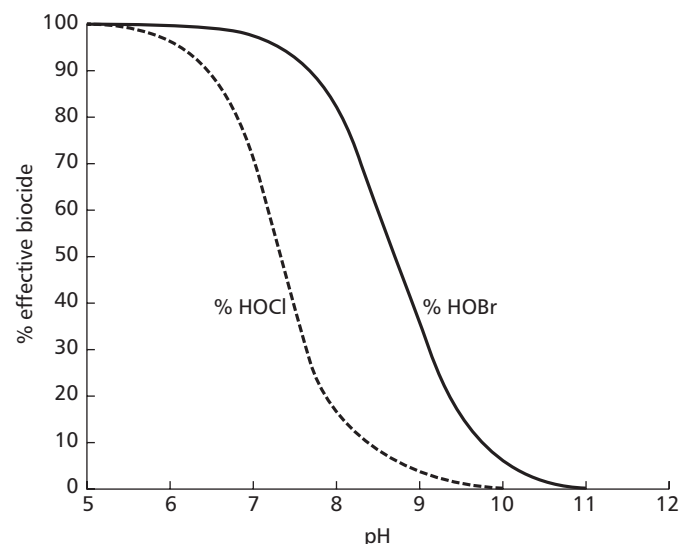

Figure 11 Relationship between effective free chlorine or bromine and pH

Intermittent chemical addition is the normal strategy adopted when using non-oxidising biocides, of which there is a wide variety. Dosing is normally for a short period at intervals of several days (known as 'shot', 'shock' or 'slug' dosing). At least two chemically different formulations are needed to guard against the possibility of a bacterial population becoming resistant to a single biocide. The quantity dosed at each addition is calculated to provide a concentration of biocide in the system which will reduce the bacteria count in the system water to a low level over the course of a few hours. To ensure that this concentration is achieved and maintained, it is good practice to close the bleed during and following biocide addition.

Many systems operate with continuous automatic addition of an oxidising biocide and intermittent addition of a non-oxidising biocide. The oxidising agent is often referred to as the 'primary biocide' and the non-oxidising agent as the 'secondary biocide'. The effectiveness and broad spectrum of kill provided by oxidising biocides is such that the non-oxidising biocide could be considered unnecessary, however the practice does ensure there is always a reserve available as a back-up. Care should be taken when selecting the non-oxidising biocide to ensure it does not react with the oxidising agent as this could result in a period following dosing where they have to some extent inactivated one another.

Ideally, chemical storage tanks should be calibrated to offer the opportunity of checking the injection flow rates as part of the day-to-day monitoring of the regime.

Non-chemical treatments

There are a number of non-chemical methodologies available to achieve the water treatment effects described above. Several non-chemical means of microbiological control are available and include irradiation of a proportion of the recirculating water with ultraviolet light, exposing the water to ultrasound, pulsed electromagnetic field, hydrodynamic cavitation, or a combination of these techniques.

The effectiveness of ultraviolet irradiation is impaired by turbidity of the water, and proprietary installations commonly incorporate filtration or supplementary dosing with an oxidising biocide, or both. The effect of ultraviolet irradiation is limited to the water passing through the light path and there is no residual biocidal effect in the remainder of the system water. Dosing with a supplementary oxidising biocide overcomes this.

Ultrasound has been shown to be effective where there is continual circulation of water within the system. However, if the water is carrying significant suspended solids there is evidence that the performance may be impaired.

Whenever microbiological control programmes are being selected, it is essential that the supplier be required to provide evidence that the product has not only been shown to kill legionellae effectively under controlled laboratory conditions but also has been proven to be effective in maintaining low microbiological levels in operational cooling tower systems.

Similarly, there are devices using magnetism or other phenomena which are used for hardness, scale, fouling or corrosion control, though many of these are regarded as unproven across the wide range of conditions in cooling water systems and have not been universally accepted as being effective. Again, it is important therefore when considering

any of these non-chemical techniques that appropriate measures are taken to ensure the efficacy of the programme across the wide range of operating conditions in cooling water systems.

In general, pre-treatment such as softening and then chemical conditioning is the proven and most reliable strategy for controlling the water quality in evaporative cooling systems. However, if non-chemical techniques are to be used, strict performance criteria should be pre-determined with regular monitoring to confirm that the desired results are being achieved. It may be advisable to ensure that there is a conventional chemical biocide available in the event of a failure of the non-chemical device.

4.3 Operation

The important operational elements when managing an evaporative cooling system are commissioning, inspection and monitoring, water sampling and testing, cleaning and disinfection, maintenance and record keeping.

4.3.1 Commissioning

It is very important that evaporative cooling systems are properly commissioned before they are put into service so that they operate safely from the outset. Cases of legionellosis have been associated with systems that were not clean or properly commissioned prior to being put into operation.

It is essential that the commissioning process is carried out in full compliance with the supplier's or installer's instructions and includes both the evaporative cooling equipment and associated water treatment plant. The same precautions taken to prevent or control the risk of exposure to *Legionella* during normal operation of cooling systems also apply to the commissioning process.

If a new system is not to be put into service immediately, commissioning should not be carried out until the system is required for use and it should not be filled until commissioning takes place. If filled for hydraulic testing only, then the system should be drained immediately thereafter.

When a new system is not put into operation immediately, but commissioning cannot be deferred (for example to complete a stage in a construction project), it must be maintained in a safe condition by a regime of treatment, monitoring and simulated use. Water treatment service providers can advise on suitable regimes, which should include, as a minimum, maintaining an effective concentration of biocide throughout the system; monitoring the water condition by measuring the concentration of biocide, the levels of bacteria or both; and circulating the water (opening bypass valves, etc.) every few days; in most cases it will also be necessary to treat the water to inhibit corrosion. This is equally important when re-commissioning an existing installation, for example following modification.

When commissioning has been completed, the Responsible Person or representative of the owner/user needs to countersign the commissioning documentation as evidence this has been satisfactorily carried out and to acknowledge they accept responsibility for the ongoing safe management of the system.

Table 2 Recommended inspection frequencies for cooling water installations

Frequency*	Task
Weekly	<p>Take a dip slide sample from as near to the heat source as possible. Incubate at 30 °C for 48 hours and investigate further if high dip slide results are obtained</p> <p>Take a representative water sample and test for key water quality parameters (oxidising biocide level, conductivity, pH, etc.) to ensure treatment programme performance</p> <p>Carry out a visual inspection of the equipment (inside and outside) and water treatment plant for general condition, cleanliness, leaks or damage</p> <p>Check the appearance of the recirculating water: is it clean and clear without excessive fouling or foaming?</p> <p>Confirm that there is no excessive drift loss</p> <p>Check that there are sufficient stocks of water treatment chemicals; is there evidence that expected quantities are being dosed?</p>
Monthly	<p>Check performance of dosing and control equipment, conductivity and redox sensor calibration, pond water level control and bleed (blowdown) function. Check uniformity of water distribution, condition of sprays/troughs, drift eliminators, fill pack or heat exchange coil, pond strainers, immersion heater, fans and sound attenuators</p> <p>Flush any cooling tower balance pipes/lines and bypasses. This should be carried out when there is adequate concentration of oxidising biocide or maximum concentration of non-oxidising biocides, depending on which is used</p> <p>Take a representative water sample and analyse for selected chemical/microbiological parameters to confirm total treatment programme performance</p> <p>Every 3 months take water sample and send to a laboratory accredited to test for <i>Legionella</i></p>
6-monthly	<p>Assess the condition of the fill pack and decide whether it requires cleaning/de-scaling and by what means. If the fill pack does require cleaning, other parts of the system, including heat exchangers etc., should also be inspected and cleaned/de-scaled as needed</p> <p>Clean and disinfect cooling tower/evaporative condenser, make-up tanks and connected condenser water system. De-scale as necessary. Fill packs should be removed for cleaning where practicable</p> <p>Review water treatment records, especially bacteriological levels; are the records well kept and do they show reasonable consistency?</p>

* Guidance only – actual frequency will depend on risk

These commissioning documents should be included as a section in the operating manual or log book (see Section 4.3.8).

4.3.2 System inspection and monitoring

Operating staff should be familiar with the mode of operation of the cooling system and be fully trained to understand and implement the operating procedures. Staff should be alerted by line management whenever building usage deviates from normal, for example during overtime working. Typically, these operatives will also carry out at least weekly checks to confirm the continued effective operation of the water treatment programme.

The water treatment specialist should provide the Responsible Person with a detailed system-specific written procedure for sampling and testing, and ensure that 'hands-on' training is provided for the operatives.

These regular checks are additional to the more detailed periodic analyses that are carried out by the water treatment service provider (see Section 4.3.3).

Comprehensive records should be maintained of both the routine day-to-day checks and the more stringent analyses carried out by the water treatment specialist.

Table 2 gives recommended frequencies for key inspections and actions when operating a cooling water system.

Steps to be taken if a cooling tower system is to be shut down for a period are described in Section 4.3.9.

Staff need to be aware that standby equipment and deadleg sections of the piping should be viewed as potentially contaminated. Allowance should be made for this when standby plant is brought into operation, or when the bypass pipe is brought back into the circuit after prolonged periods of full-load operation.

4.3.3 Water quality testing and monitoring

Testing and monitoring procedures should be set up to ensure normal water quality control parameters and limits are being met as well as to identify any deviations from the norm and enable appropriate corrective action to be taken. The degree, frequency and inclusion of any procedure within the water testing regime should be defined by the implications (and importance) of the parameter as well as the complexity of the monitoring activity.

Regular checks on the water quality are essential and can be divided into two categories.

The first is those that are quick and simple and are carried out weekly by operatives or maintenance staff trained for the task. In the case of oxidising biocides, such as chlorine and bromine, or systems not in stable operation or not fitted with failure alarms, more frequent or even daily testing should be considered.

The other testing is that carried out, usually monthly, by a qualified service chemist from the water treatment provider. At sensitive locations, such as hospitals, more frequent checks by a service chemist may be required.

The water treatment specialist should provide written guidance identifying suitable limits for the measured values being tested, and on the actions needed whenever the measured values reach or exceed such limits.

Monitoring also needs to include other measures of the management and efficacy of the water treatment programme. These include parameters that act as controls, such as chemical inhibitor reserves and biocide concentration levels (which may be considered an 'indicator' of performance), and other parameters that actually quantify the effect, such as measuring the corrosion rate by the means of metal coupons, or bacteriological levels by the means of dip slide or plate count.

More frequent water sampling should be carried out when commissioning a system and setting up the treatment programme.

As was stated earlier, it is important when reviewing control strategies to differentiate between the cause (biocide concentration) and the effect (microbiological level), although they are obviously linked.

Table 3 Typical cooling tower water monitoring checks: recommended frequencies for good operating practice

Parameter*	Make-up water	Cooling water
Calcium hardness as mg/l CaCO ₃	Monthly	Monthly
Total hardness as mg/l CaCO ₃	Monthly	Monthly
Total alkalinity as mg/l CaCO ₃	Quarterly	Quarterly
Chloride as mg/l Cl	Monthly	Monthly
Sulphate as mg/l SO ₄	Quarterly	Quarterly
Conductivity (µS/cm) (total dissolved solids)	Monthly	Weekly
Suspended solids (visual inspection)	–	Monthly
Inhibitor(s) level (mg/l)	–	Monthly
Oxidising biocide (mg/l)	–	Weekly
Temperature (°C)	–	Quarterly
pH	Quarterly	Weekly
Soluble iron as mg/l Fe	Quarterly	Quarterly
Total iron as mg/l Fe	Quarterly	Quarterly
Cycles of concentration	–	Monthly
Aerobic bacteria (cfu/ml)	Quarterly	Weekly
<i>Legionella</i> (cfu/l)	–	Quarterly

* Operating limits for these parameters to be specified for each site.

Table 4 Action levels following microbial monitoring for cooling towers

Aerobic count (cfu/ml at 30 °C) (minimum 48 hours incubation)	<i>Legionella</i> (cfu/l)	Action required
10 000 or less	100 or less	System under control
More than 10 000 and up to 100 000	More than 100 and up to 1000	Review programme operation: a review of the control measures and risk assessment should be carried out to identify any remedial actions and the count should be confirmed by immediate re-sampling
More than 100 000	More than 1000	Implement corrective action: the system should immediately be re-sampled. It should then be 'shot dosed' with an appropriate biocide, as a precaution. The risk assessment and control measures should be reviewed to identify remedial actions

Table 3 shows a listing of typical water quality monitoring checks and frequencies for an evaporative cooling system.

4.3.4 Routine sampling for aerobic bacteria

The monitoring programme should always include routine sampling and testing for the presence of bacteria, both for general (aerobic) bacterial species and specifically for *Legionella*. Since the detection of *Legionella* requires specialist laboratory techniques, routine monitoring for aerobic bacteria is used as an indication of whether microbiological control is being achieved.

The most common method of measuring microbiological activity within a cooling system is to use a dip slide. Dip slides should be wetted in the system water as near to the heat source as possible. If a drain cock is used it is important that some water is run off before the slide is wetted to obtain a representative sample. The dip slide should then be replaced in its container and incubated for a minimum of 48 hours in an incubator, usually at 30 °C. (Note that the incubation period and temperature for cooling towers differ from those commonly used in the water supply industry.) The incubation period and the temperature should be the same each time the test is performed.

Dip slides are only a reflection of the general bacteriological level in the system water, and do not measure directly the presence of *Legionella*.

See also Section 3.6.

4.3.5 Monitoring for *Legionella*

In addition to the routine sampling for aerobic bacteria, the monitoring scheme should include periodic sampling for the presence of *Legionella*. It is recommended in most countries, mandatory in others, and advocated by the HSE in the UK to be undertaken at least quarterly. Sometimes more frequent sampling is necessary for other reasons, such as to assist in identifying possible sources of the bacteria during outbreaks of Legionnaires' disease, to test the efficacy of a new water treatment programme or as part of the commissioning process.

Samples should be analysed at a laboratory accredited for testing to BS EN ISO/IEC 17025:2005 by an appropriate national accreditation body such as UKAS in the UK. *Legionella* should be included in the laboratory's scope of accreditation and testing for *Legionella* by culture should be carried out in accordance with ISO 11731:1998 or future revisions. The laboratory should be capable of a detection limit of less than or equal to 100 *Legionella* per litre of sample.

Table 5 Indicative maintenance schedule for a cooling tower or evaporative condenser

Description	Weekly	Monthly	Quarterly	6-monthly	Annual
Inspect general condition of unit	✓				
Check unit for unusual noise/vibration	✓				
Check alternation of duplicate pumps and operate standby pumps	✓				
Remove and clean sump strainer		✓			
Check operating level in pond and adjust float valve as required		✓			
Check water distribution system and nozzles		✓			
Check orientation and condition of drift eliminators		✓			
Check pond heaters and accessories		✓			
Check and lubricate fan drive system			✓		
Check fan belt tension and adjust as needed			✓		
Check motor(s) voltage and current			✓		
Drain pond, clean debris and flush				✓	
Inspect condition of heat transfer fill pack or heat exchange coil and clean as required (see Section 4.3.7)				✓	
Inspect condition and clean internally wetted surfaces				✓	
Service water treatment plant, controls and dosing equipment					✓

Other more rapid methods can be used for *Legionella* testing, including qPCR (see Section 3.6.2). Any laboratory using these methods should be accredited for this testing.

The sampling method should be in accordance with BS 7592:2008). Samples should be taken when the biocide levels are at a minimum, be taken as near to the heat source as possible, have the biocide neutralised if possible at the time of sampling and be analysed as soon as practicable and within 24 hours of collection. If the biocide cannot be neutralised it is particularly important that the analysis take place as soon as possible after collection otherwise the biocide may continue to act causing an underestimate of the numbers of legionellae.

Legionella is commonly found in almost all natural water sources, so sampling of water systems and services will often yield positive results. Failure to detect *Legionella* should not lead to the relaxation of control measures and monitoring. Neither should monitoring for the presence of *Legionella* in a cooling system be used as a substitute in any way for stringent application of control strategies and those measures identified in the risk assessment. If a *Legionella*-positive sample is found, more frequent samples may be required as part of the review of the system/risk assessment, to help establish when the system is back under control.

Table 4 gives current guidance in the UK on action to be taken according to the aerobic count or numbers of *Legionella* found in the cooling water system.

4.3.6 Maintenance

A simple, itemised schedule for routine inspection and maintenance is essential. This should include the intervals at which the necessary inspection, checks and mechanical and electrical maintenance (for example, lubrication, fan drive adjustment, operating water level, etc.) should be carried out. This maintenance programme should include the cooling tower or evaporative condenser, water softening plant, storage tanks, filtration systems and water treatment plant dosing and control equipment.

The maintenance requirement schedule must be provided by the equipment manufacturer or installer and based on

good practice. A typical maintenance schedule for a cooling tower or evaporative condenser is shown in Table 5.

All maintenance activities need to be documented as part of the system record keeping (see Section 4.3.8).

4.3.7 Cleaning and disinfection

Cleanliness of the cooling system is a key factor in avoiding the risk of *Legionella* proliferation. Outbreaks of Legionnaires' disease have invariably been associated with poor water quality and a dirty system, including when cooling towers are first put into operation or at start-up after a lengthy shutdown. Where the tower is in use only during the summer, the system must be cleaned and disinfected immediately before it is put back into use. The disposal procedure for treated or dirty water should be agreed with the local water company.

Cooling towers serving air conditioning systems and those in continuous use should normally be cleaned and disinfected twice each year, in early spring and early autumn. More frequent cleaning will sometimes be necessary, especially in areas of high atmospheric pollution or where there is local dustiness, for example in the vicinity of construction or demolition works or where the make-up water is supplied from a non-potable source. Cleaning and disinfection should also be carried out after any modification work on the system.

There are three stages in the cleaning and disinfection process:

- pre-chlorination of the whole system together with addition of a dispersant
- thorough cleaning of the whole system, dismantling as necessary
- post-chlorination.

Note that advice should also be obtained from the local water company regarding disposal of the water containing concentrated chlorine, but it will generally be acceptable to

neutralise the chlorine with sodium thiosulphate or sodium bisulphite solution before discharge to drainage.

A site-specific method statement for cleaning and disinfection is needed.

Pre-chlorination should be carried out by dosing the system water with chlorine and then circulating the chlorinated water throughout the system for a sufficient period with the fans switched off. At the end of this period the system water should be de-chlorinated and drained.

The effectiveness of chlorination depends on the concentration and contact time and in general a decrease in one can be compensated for by an increase in the other. This does not hold true for all disinfectants and for chlorine it is generally regarded as applicable for chlorine concentrations from 10 mg/l to 50 mg/l. If the chlorine concentration in mg/l (parts per million) is multiplied by the contact time in hours and the product is 50 parts per million hours, the disinfection effect can be considered as equivalent.

Longer contact times are the preferred option and typically for pre-chlorination this should be 10 mg/l free chlorine for 5 hours. If it is not possible to shut down the system for an extended period it is acceptable to increase the chlorine level and reduce the circulation time to 25 mg/l free chlorine for 2 hours or 50 mg/l for 1 hour. Periods above 5 hours or less than 1 hour are not recommended. Note that shorter contact times at higher concentrations may not always have the same penetrating effect as longer periods at lower concentrations and additional measures may be necessary.

Care must be taken not to over-chlorinate, as this could lead to corrosion or damage to special coatings used on components in the water circuit.

Two important steps must always be taken with chlorination. The first is to measure accurately the level of free chlorine in the system water. The simplest, most rapid, reliable and low-cost method of determining the level of free chlorine is to use chlorine HR ('high range') tablets. This is a colorimetric method in which chemical tablets are added to the water sample and the resulting colour is matched to a calibrated range. Chlorine is very reactive, and will combine readily with organic compounds within the water. Thus more chlorine will need to be added than the theoretical calculation would suggest.

The second step is to monitor the pH as the biocidal effect of chlorine decreases rapidly at pH values above 7 (see Figure 11), and although the measured free chlorine is at the desired level, the chlorination may not be effective if the pH is too high. The solution is to either adjust the pH down to 7 by adding an acid or augment the chlorine dosage with sufficient sodium bromide to convert the chlorine to bromine. As a further measure to improve the effectiveness of the chlorination, a chemical dispersant is usually added prior to, or along with, the chlorine in order to improve penetration into accumulations of sludge, sediment and biofilm. This is especially important if the system is known to be fouled, or has been exposed to significant airborne contamination from nearby construction work, etc. By their nature dispersants can cause foaming so care must be taken to avoid excessive foaming which can cause pump cavitation or even

dissemination of chlorinated foam from the tower. Dispersants should be added in accordance with the supplier's instructions and using a suitable anti-foaming agent when needed.

Bromine or chlorine dioxide at appropriate concentrations may be used as a substitute for chlorine noting that these are more effective at higher pH than chlorine.

The cleaning operation comprises stripping down the tower and its components, including louvres, baffles, drift eliminators, water distribution system and the fill pack. These should be cleaned and de-scaled and any damaged or deteriorating components replaced. The pond itself should be drained and thoroughly cleaned, and all organic matter and scale removed. All system strainers, including the tower suction screens, should be cleaned. Methods of physical cleaning include brushing, scraping, scrubbing, hosing and vacuuming. Acid or chlorine dioxide based foams can be used to soften or dislodge stubborn deposits on surfaces and then rinsed with water.

The HSE in the UK has issued supplementary guidance on the removal of fill pack from cooling towers for cleaning. The recommendation is that the fill pack is removed at least once per year, but in circumstances where this is not reasonably practicable because of size, design, not being able to shut down the cooling system, other health and safety factors or excessive cost, it is acceptable to take other measures providing the overall cleanliness of the fill pack and system are maintained and can be demonstrated. This requires a condition appraisal of the cleanliness and condition of the fill pack and an effective means of cleaning the fill pack in situ if it is not to be removed. If the fill pack is brittle, heavily fouled or damaged it is often more economic to replace it, but care needs to be taken that any replacement fill has the same dimensions and equivalent performance as the original pack.

It is advisable to keep proper records, including photographic evidence or borescope images of sections of the fill pack, before and after cleaning, to demonstrate the efficacy of the cleaning and disinfection.

Normal protective clothing is adequate for all internal inspections and cleaning operations. High-pressure cleaning lances are likely to generate intense aerosols and their use is not recommended. However, if such equipment is necessary then the cleaning should be carried out when the building is unoccupied or, in the case of permanently occupied buildings, windows in the vicinity should be closed and air inlets blanked off; in addition the area that is being water jetted should be tented to contain the bulk of the droplets. The area should be isolated and consideration should also be given to the means of protection of other occupied buildings in the immediate areas as well as members of the public who may be in the vicinity during cleaning.

Measures need to be taken to ensure good quality breathing air for cleaning staff who carry out water jetting, including wearing suitable respiratory protective equipment. Staff using this equipment should be adequately trained and the equipment properly maintained.

When all cooling tower components have been cleaned and reassembled, post-chlorination should be carried out

in the same way as the pre-chlorination. The system should be filled with fresh water and chlorinated to 10 mg/l of free chlorine. The pH should be maintained at 7, or the free measured chlorine should be adjusted to match the existing pH. The treated water should be circulated through the whole system, including the tower, again for a period of 5 hours. The effective free chlorine concentration should be maintained during this period. Circulation should be carried out initially with the cooling tower fans switched off, but after a significant period the fans may be switched on in order to ensure thorough wetting of all the internal surfaces. Note, however, that chlorine will tend to be stripped from the water by the action of the fans and therefore the chlorine level must be closely monitored. As with the pre-chlorination, it is acceptable to increase the free chlorine level and reduce the circulation time when downtime is limited. The system should then be de-chlorinated, drained, the tower refilled with fresh water and the established water treatment programme immediately reinstated.

The cleaning procedures described here apply to a well-maintained and carefully operated tower. In emergencies a more comprehensive procedure is required; this is described in Appendix A2.

4.3.8 Record keeping system

Proper documentation and record keeping are an essential part of good management of cooling systems.

The operating manual for the system must be supplied by the equipment supplier or installer as a part of the handover of the system to the owner/user.

Either as part of this manual or separately a cooling system log book, which contains the documentation and records associated with demonstrating the safe operation of the cooling system, is needed.

The cooling system log book should include:

- cooling system risk assessment
- written control scheme
- details of key personnel including the statutory Duty Holder, nominated Responsible Person (and their deputies), other staff with specific tasks and the water treatment service provider
- schematic diagram of the cooling water system
- allocation of tasks for the safe operation of the system
- commissioning records and local authority notification
- training records of operatives
- method statements for inspection and maintenance and cleaning and disinfection
- Chemical COSHH assessments and material safety data sheets
- records/reports of all inspections, monitoring checks, service chemist visits, water analyses, maintenance, cleaning and disinfection certificates, photographic evidence and repairs

- identification of non-compliances and corrective action taken.

The cooling system log book needs to be kept up to date and readily accessible for inspection by local environmental officers or HSE inspectors.

4.3.9 Arrangements for cooling tower or evaporative condenser system shutdown

For a shutdown for less than a month, or when the system cannot be drained because it may need to be returned to service at short notice (such as where it is to reject heat from an emergency generator), a corrosion and scale inhibitor and biocide should be added and the water circulated to ensure mixing throughout the system. Thereafter the water should be recirculated at least once a week and more chemical added periodically. Frost protection should be maintained.

For a prolonged shutdown it is recommended to drain closed circuit cooling towers and evaporative condensers with the drain valve left open. Draining of small open circuit cooling tower systems may also be feasible. An alternative procedure is to leave the system full with treated water and again circulate the water at least once per week. Before putting back into service, the system should be drained, cleaned as necessary, flushed, and refilled with fresh water disinfected to 10 mg/l effective free chlorine. This free chlorine level should be maintained for 5 hours giving the desired disinfection effect of 50 parts per million hours. The water should be circulated throughout the system with the fans switched on for a part of the period and then be de-chlorinated and drained. The system can then be refilled with fresh water and the established water treatment programme reinstated.

4.4 Control

Efficient and safe operation of evaporative cooling systems can be ensured with good design, an effective water treatment programme and regular maintenance and cleaning. The following list details some quick management indicators to show that all is well:

- a visual inspection of the equipment (inside and outside) and water treatment plant for general condition, cleanliness, leaks or damage
- appearance of the recirculating water: is it clean and clear without excessive fouling or foaming?
- confirmation that there is no excessive drift loss: is there any clearly visible drift at either the air discharge or intake?
- sufficient stocks of water treatment chemicals; is there evidence that expected quantities are being dosed?
- proper water treatment records, especially bacteriological levels; are the records well kept and do they show reasonable consistency?

A more detailed system checklist is given in Appendix A4.

5 Hot and cold water services

5.1 Introduction

Domestic hot and cold water systems are the second most common cause of cases of Legionnaires' disease after cooling towers and evaporative condensers. Hot and cold water systems of any size can become colonised, and even those in single households can cause cases, but the greatest risk is from complex hot and cold water systems, such as those in hospitals and hotels, which provide many potential sites for colonisation by legionellae. In contrast to the explosive outbreaks over short periods commonly caused by cooling towers, those caused by domestic water systems tend to have smaller numbers of cases that are spread out over weeks, months or even years. The reason for this is the random and variable degree of colonisation that occurs throughout complex water systems.

Small numbers of legionellae entering water systems will be distributed randomly around it. Some will die as a result of biocides in the water or temperatures above 50 °C, others will be simply washed out of the outlets, but some will find environments, usually in the outlets, suitable for their growth and settle down and colonise there.

Conditions most conducive to legionellae growth occur in the outlets themselves for a combination of reasons, including: the presence of materials such as flexible seals and hoses that can provide nutrients and support microbial growth; periods of stagnation; reduced hot water temperature and increased cold water temperatures; the presence of dirt and scale deposits; the reduction in biocide concentration and the presence of many crevices and pockets where biofilm can be harboured and protected. If a tap or shower has become colonised and is not used for several days the legionellae population may increase so that the first person to use it is exposed to a sufficiently large number of legionellae to cause infection in a susceptible individual. The first opening of the tap flushes out most of the legionellae that have accumulated within the plumbing fitting so that if used frequently thereafter the numbers remaining are not sufficient to create an infectious dose for subsequent users.

A consequence of the random initial colonisation of water systems is that it is unusual for whole hot or cold water systems to be colonised. The prevention of outbreaks caused by hot and cold water systems depends on a comprehensive application of a water safety plan with assiduous attention to good design, management and control of the system.

To protect public health in the UK, all mains water supply piping must be disinfected by the addition of chlorine before initial use. Subsequently, the water companies supply chlorinated mains water, although the residual chlorine level is small. Mains water may contain very small quantities of *Legionella*, although there is no direct link between mains water supply and Legionnaires' disease. Engineers should assume the presence of *Legionella* and design the water system to avoid those conditions at which *Legionella* can multiply.

The general principles to control the risk are detailed below.

- (a) *Temperature control*: this means ensuring that the incoming mains water is protected against heat gains. The guidance to the Water Regulations, the *Water Regulations Guide* (WRAS, 2001) states that wholesome water should be kept as cold as possible, ideally below 20 °C; however, the Water Supply (Water Quality) Regulations 2010, known as the 'Water Quality Regulations', do not specify a maximum temperature for mains water supplies and supply temperatures above 20 °C seem to be increasingly common. That guidance also states that hot water should be stored at a temperature of not less than 60 °C and distributed at a temperature of not less than 55 °C. (Note this may not be practicable in the case of instantaneous or combination boilers.)
- (b) *Storage time*: for cold water the storage time should be minimised. For hot water prolonged storage time at high temperatures is beneficial because it aids the *pasteurisation effect*.
- (c) *Minimal nutrients*: the UK Water Regulations Advisory Scheme (WRAS) publishes a list of suitable materials in the *Water Fittings and Materials Directory* (www.wras.co.uk/directory/) which are neither toxic nor provide nutrients which support the significant growth of micro-organisms. Fittings and materials for sealants, gaskets and washers should be selected from this list. Refer also to BS 6920-1:2000.
- (d) *Careful monitoring and recording*: all water services should be routinely checked, inspected and well maintained. Records must include an accurate description of the system and its location within the building. The records should also show the date and details of inspections and measurements, and must include the name of the person undertaking the survey. Details of any non-compliance revealed by the survey and remedial actions taken should also be recorded.

The traditional temperature regime method for controlling the multiplication of *Legionella* in hot and cold water services systems remains valid and has generally proved to be effective. The necessary temperatures for effective control are detailed in Sections 5.2.2 and 5.3.2. For systems where temperature control is poor and that present ongoing operational difficulties, a number of biocidal supplementary treatments may be considered. These treatments must be controlled with great care, particularly where the water is for potable usage in which case they must also be approved for use in drinking water.

There are several treatments that have been used, the more common of which include chemical dosing of the systems with supplementary chlorine or chlorine dioxide, and ionisation treatment using silver and copper electrodes. For chlorine dioxide (measured as the total of oxygen-chlorine compounds and expressed as chlorine dioxide), the maximum limits for drinking water are 0.5 mg/l. The treated water must be monitored carefully to check dosage levels. At the time of publication, however, the use of copper-silver ionisation has not received approval as a biocide, and until this is confirmed, or a derogation granted (as is expected), it cannot be approved for use on domestic

water supplies; this includes water for drinking, food preparation, washing, sanitation and laundry.

Where users are at especial risk, such as in some healthcare premises, and where conventional temperature and supplementary regimes are not successful, disposable terminal fittings incorporating WRAS-approved membrane filters have been used successfully to prevent *Legionella* being discharged from the system. The particular benefit of this technique is to control risk immediately in the short term so systems (and therefore the areas they serve) can remain in use while corrective action is taken: long-term use is not recommended because it could be considered to breach the requirement to eliminate the hazard, and the ongoing cost of replacement filters.

Whenever a decision is taken to apply any supplementary treatment, the Responsible Person should ensure that the specialist supplier provides detailed instructions on the acceptability of the regime being introduced, as well as the operating, monitoring and dosing arrangements. It is also important for the supplier of the treatment to attend site on a regular basis to run their own checks on the dosing operation.

5.2 Cold water services systems

5.2.1 Introduction

Although most outbreaks caused by domestic water systems have been caused by hot water systems, cold water systems can also become colonised, particularly if the water temperatures are above 30 °C. Although such temperatures are commonly associated with cold water systems in the tropics and on ships they can occur in temperate climates as well. In the latter case, high cold water temperatures may occur due to a combination of increased hot water temperatures and poor insulation, bad design, failure of backflow devices in mixers and stagnation, etc. Increasingly, in modern buildings in which colonisation in the hot water system is controlled well by heat, colonisation of the cold water system occurs.

5.2.2 Design

The design requirement is to avoid water temperatures reaching those tepid conditions at which *Legionella* can multiply. Cold water pipe routes should avoid hot zones and should be insulated to preserve, as far as is practicable, a temperature below 20 °C. Water fittings with high usage, for example frequently used toilets, should be located at the end of system branches to ensure the best possible water displacement in order to minimise stagnation.

Cold water storage cisterns have traditionally been sited at high level in the building and are commonly in or on the roof. Current practice increasingly uses boosted water supply with the storage cistern sited in the basement, which generally has the advantage of a cooler environment. Water services storage cisterns should comply with the Water Supply (Water Fittings) Regulations 1999.

Cisterns should be provided with a tightly fitting removable cover to protect against ingress of dirt. The cover of small cisterns should be removable to allow for inspection of the cistern and its water content and for maintenance of the

float-operated valve. Larger cisterns should be provided with a cover for float-operated valve maintenance and additional hatches as necessary for inspection. Provision should be made for cleaning internal surfaces of the cisterns without major interruption of supply. Insect- and vermin-proof screens should protect any overflow and vent pipes. Although domestic hot water system expansion pipes are permitted to vent into cold water cisterns, better practice is to vent them into a separate tundish with an air gap above to prevent any possibility of back contamination and to allow early visual warning of any problems with the domestic hot water system.

Cooler conditions for externally sited cisterns can be more readily achieved by screening from direct sunlight, by painting with a reflecting paint or insulating them. Where the cistern is installed inside a roof, then the roof should be well ventilated. The Water Supply (Water Fittings) Regulations 1999 require cisterns to be thermally insulated to protect the water from temperature extremes.

On all cisterns inlet and outlet pipes should be positioned to generate a cross-flow of water across the vessel. Where water has to be stored in two cisterns because of space limitations or for other reasons, it is essential that provision is made for flow to occur through both simultaneously, e.g. by coupling in series. Multiple cisterns present a particular risk where the water flow is mainly through one cistern and the others remain full of static water, which can gradually warm up during summer weather. Supply and outlet pipework should be configured to ensure that flow displaces all of the stored water where there are interlinked cisterns.

Design storage capacity and tank identification number should be clearly marked on each cistern and capacity based on the likely maximum duration of interruption of mains supply to the building. This should typically be expected to be no more than one working day. If a longer storage time is necessary, additional treatment may be needed; this requires provision for regular or continuous chlorination or other means of disinfection such as chlorine dioxide dosage or ionisation. These treatments are described in the HSE ACoP and Guidance L8 (HSE, 2000), but are not recommended where water is for human consumption and should only be considered for non-drinking water systems where risk assessment indicates there is a need but it is not practicable to maintain the water quality by design changes. CIBSE Guide G: *Public health engineering* (CIBSE, 2004) provides further information on water storage volumes.

If parts of the water system can be taken out of service, for example unoccupied floors in office buildings, consideration should be given to the capability to isolate and drain down such parts of the system. When re-commissioned, the system should be appropriately disinfected prior to re-introduction.

In addition, the volume of stored cold water should be reviewed during periods of low occupancy to ensure adequate turnover of water throughout the system.

5.2.3 Operation and maintenance

Cold water systems should be disinfected before being brought into use:

- (a) when newly constructed
- (b) after modification
- (c) after being decommissioned
- (d) after a period out of use without being decommissioned.

Cold water should be stored below 20 °C as far as is practicable. Cases of Legionnaires' disease have been associated with cisterns that have been allowed to become tepid, and where this tepid water has remained in the cistern for an extended period. Water temperatures in excess of 25 °C anywhere in the system should be deemed unsatisfactory, except where they are known to be very local (such as the first litre or so after opening a tap) or when they are known to be temporary (such as when the mains water supply is warm and the weather is hot).

The temperature of the cold water should not exceed 20 °C; however, pipes which share service voids with hot water services, heating or other heat sources may become considerably warmer. An exercise should therefore be carried out to discover if this effect is excessive by flushing representative taps (for example, the furthest on each branch) while continuously measuring the temperature for up to 2 minutes. Where there is reason to expect significant seasonal variation (i.e. temperatures might reasonably be

expected to exceed 25 °C in the height of summer when water supply and ambient temperatures are at their maximum or in the depth of winter when heating systems are operating at their maximum) it might be necessary to repeat this exercise.

Annual inspection of cisterns is essential. If there is significant contamination then cleaning is necessary (it is likely that there will be a small quantity of sediment, typically quite inert sand-like material, in any cistern and a judgement needs to be made as to whether the quantity or nature is of concern). Sludge, scale and corrosion debris need to be removed, and where surface deterioration is evident, the cistern should be coated with a suitable paint approved within the WRAS *Water Fittings and Materials Directory* or replaced as necessary. The drying time, temperature and ventilation specified by the manufacturer for such paints and coatings must be observed. In some cases this may be prolonged, and the associated temperature requirements exacting. Chlorination after painting is not recommended unless approved by the coating manufacturer, as high chlorine concentrations can damage the coating. When chlorination is carried out, the chlorine should be added after the water. Other types of cistern construction, such as glass-reinforced plastic, will have different maintenance requirements and manufacturers' recommendations should be followed.

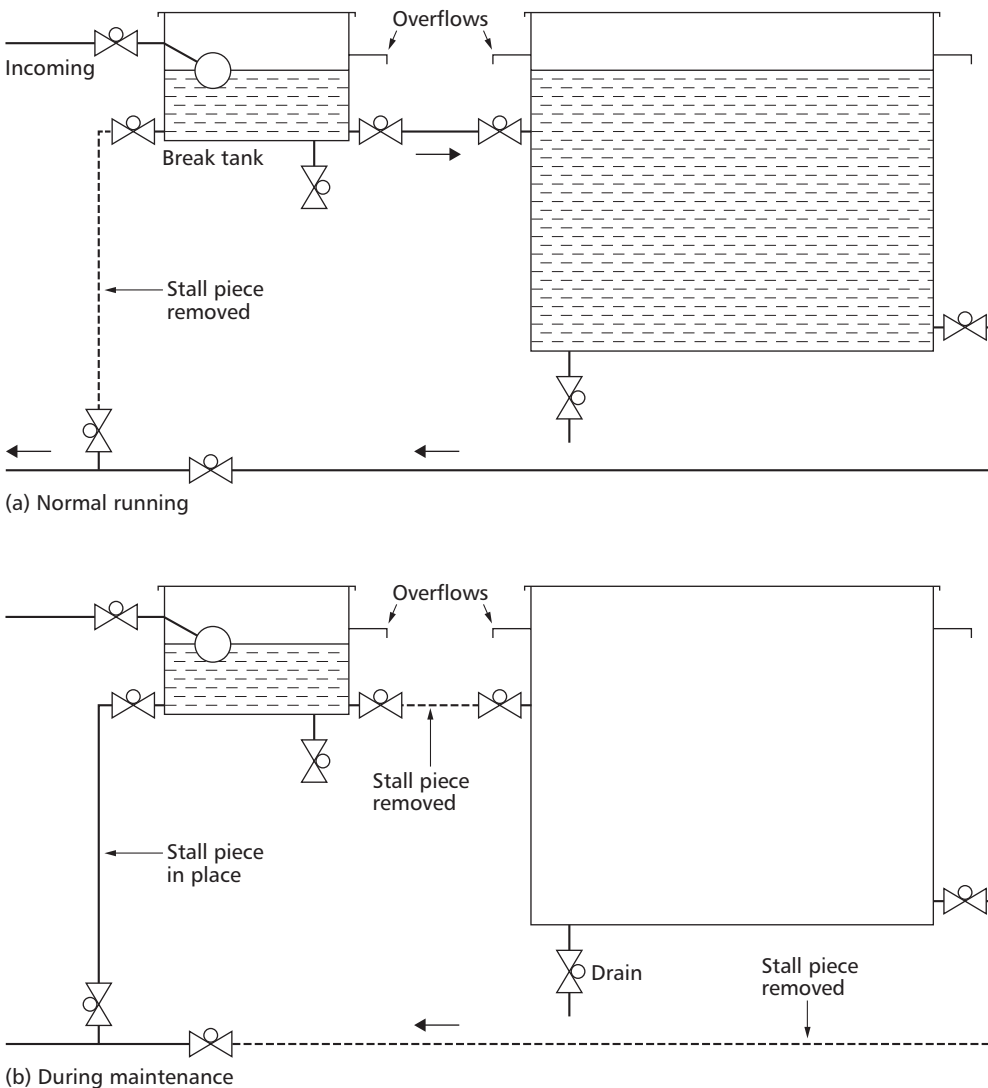

Figure 12 Piping and arrangements for break tank operation

BS EN 806-4:2010, Section 6.3.3 'Methods for using disinfectants', identifies the following procedure:

The system shall be filled with the disinfectant solution at the initial concentration and for the contact time specified by the manufacturer of the disinfectant. If the residual of the disinfectant at the end of the contact time is less than the manufacturer's recommendation, the disinfection procedure shall be repeated as necessary until the residual concentration is achieved after the appropriate contact time. After successful disinfection, the system shall be immediately drained and thoroughly flushed with drinking water. Flushing shall continue in accordance with the disinfectant manufacturer's instructions/recommendations or until there is no evidence of the disinfectant being present, or is below a level which is allowed by national regulations. Persons undertaking the disinfection shall be suitably qualified.

After flushing, sample(s) for bacteriological analysis shall be taken and analysed. Where a bacteriological analysis of the samples indicates that adequate disinfection has not been achieved, the installation shall be flushed out, re-disinfected and further samples shall be taken.

A complete record of the details of the whole procedure and test results shall be made and handed over to the building owner.

Other considerations are that the components to be disinfected should be cleaned thoroughly and then soaked in a solution of chlorine dioxide or chlorine in fresh, clean mains water, ensuring that all surfaces are in contact with the disinfecting solution. The initial concentration of disinfectant in mg/l (parts per million) and contact time in hours multiplied together should equal 50 for either chlorine dioxide or chlorine, but only within the range 10–50 mg/l, so the minimum time would be 1 hour at 50 mg/l, while the minimum disinfectant concentration of 10 mg/l would require 5 hours. In practice, there is likely to be some reduction in concentration during the contact time, but if this is excessive it might indicate contamination, so the final concentration multiplied by the contact time should equal at least 30; if it is any less, the cleanliness of the components should be checked, they should be cleaned if necessary and the disinfection repeated.

Where continuous cold water service is required the introduction of a small break tank should be considered. In Figure 12 the large single mains storage cistern is supplied from a small break tank. The break tank's float-operated valve should be sized for the maximum building draw-off rate. The pipework connections and valving need to be arranged to enable the supply to be taken temporarily from the break tank whenever maintenance is needed on the large storage cistern.

Cleanliness of water softeners and filters is important and is best achieved by knowing and following the manufacturer's instructions. Strainers should be checked regularly for build-up of contaminants.

5.2.4 Monitoring

The temperature of the cold water inlet to the storage cistern should be measured and recorded during typical winter and summer conditions, and should preferably be below 20 °C. If there are excursions above 20 °C then the level of insulation and storage volume need to be considered.

Cisterns and the water in them should be visually inspected annually. The inspection should include all fittings

associated with the cistern, including thermal insulation and vents. Any faults should be recorded and appropriate remedial action taken.

Typical daily water consumption should be recorded and checked against the cistern capacity. When the building use or occupancy level changes, this check should be repeated. Where possible, stored volume should be reduced to match one day's actual usage.

Once the temperature characteristics of the cold water system have been established (see Section 5.2.3), any parts which exceed 25 °C should be identified as presenting an elevated risk and this should be taken into account in the scheme of control and selection of points for routine temperature monitoring. Routine temperature monitoring of cold water will usually be carried out at monthly intervals (but might be more or less frequent depending on the risk assessment and temperature characteristics) and should comprise running representative taps (for example, the furthest on each branch) for up to 2 minutes, or until a stable temperature below 20 °C is obtained, recording the maximum and final temperatures.

Where water softeners or filters are used, these should be checked and cleaned on a regular, routine basis, and manufacturers' recommendations should be followed. They can become colonised with micro-organisms and therefore should also be capable of being disinfected as required.

Records should include a schematic plan of the system, and an annual check should be made to ensure that this is kept up to date. Any outlets no longer in use should be removed.

5.3 Hot water services (HWS) systems

5.3.1 Introduction

Hot water services systems have been associated with outbreaks of Legionnaires' disease. They require special attention because any residual free chlorine in the mains supply water disappears rapidly on heating. The main protection against multiplication of legionellae is therefore temperature control and system cleanliness.

5.3.2 Design

Hot water can be generated at or close to the point of use using small units and this arrangement is likely to provide a low *Legionella* risk in many buildings. Most large buildings, however, have central hot water systems incorporating one or more storage vessels (usually a calorifier) to cater for variations in demand during the day. Where more than one unit is used, particular attention is required to ensure that water flows through all vessels.

Electric immersion heaters or hot water or steam coils are provided in the calorifier to heat the water. The storage temperature, controlled from a thermostat, should be as close to 60 °C as practicable without being any lower and the calorifier should be capable of maintaining a supply temperature of 60 °C under normal operating conditions, including times of peak demand. Distribution pipework design should enable hot water to reach all outlets within a few seconds of turning on the tap: the minimum temperature

required is 50 °C, but in most cases it will be at 55–60 °C; the maximum flush time to achieve this is 1 minute, but in most cases the time required will be considerably less.

The conventional way to ensure that hot water is delivered to all outlets quickly in larger buildings is to configure the hot water distribution system as a circuit of one or more loops through which water flows from the calorifier to the farthest point (or points) and back to the calorifier, usually re-entering above the mid-point, typically around one-third from the top of the vessel. The pipe run(s) from the calorifier to the farthest point is denoted the flow leg(s) (often abbreviated to HWSF, from 'hot water service flow') and the outlets would normally be connected to this; the pipe run(s) back to the calorifier is the return leg(s) (often abbreviated to HWSR, from 'hot water service return') and is usually of smaller size. To ensure an adequate circulation rate through the hot water circuit a pump is installed, usually on the return leg close to the calorifier, which runs whenever the system is operational.

This configuration of calorifier and distribution system, with or without circulation, leads to stratification with cold water in the base and hot water above, creating a zone at the interface where legionellae multiply, so conventional practice is to install a separate pump (often called a shunt pump) to draw hot water from the top and inject it in the base for 1 hour in every 24 with the heating element on, so the whole vessel reaches 60 °C. If this is done before the start of the working day, the extra hot water is used in the normal course of operation and there is little additional energy use.

Disrupting thermal stratification with a shunt pump is likely to result in heated water passing into the cold feed, in which case a non-return device will be required such as a convection trap (an inverted U into which heated water floats and is held) or a mechanical non-return valve. Note that a convection trap might require a vent to prevent airlocking and a mechanical non-return valve closes an expansion route and should only be installed once it has been confirmed that there is adequate facility for expansion, for example by confirming that the open vent is clear. It is also possible that hot water will be discharged via the open vent (which should not be directed into the cistern but via an air gap to a tundish connected to a warning pipe discharging in a position where hot water does not create a risk), in which case it will be necessary to adjust the pump settings.

Pre-heating water to less than 60 °C, for example using heat recovery or low-density heat sources such as 'waste' heat recovery or, in cooler weather, solar collectors, is likely to increase the risk of *Legionella* growing (depending on temperature, time for which the water is warm, water throughput and the application of any controls). Heating water to lower temperatures must therefore be clearly understood and closely monitored to ensure the risk is accurately known. In general, the assumption should be made that *Legionella* will grow in such systems, so additional measures are required to control the risk of *Legionella* proliferation, even though these may erode some of the energy savings of using such sources.

Calorifiers should be capable of heating to more than 60 °C so it is possible to carry out a thermal disinfection of the whole hot water system, commonly known as pasteurisation. This might be required following a period out of use or an unsatisfactory bacteriological result (i.e. *Legionella*-positive)

or as an interim measure in the event of loss of temperature control. In these instances pasteurisation should be carried out every few days and no less often than weekly until repair is effected.

Pasteurisation can be achieved as follows.

- (a) Put in place scald protection precautions to protect users; ideally take the system out of use.
- (b) Switch off the system circulating pump and switch on the shunt pump.
- (c) Increase the thermostat setting to raise the temperature of the whole calorifier to more than 60 °C for 1 hour.
- (d) Switch off the shunt pump and switch on the system circulating pump to raise the temperature of the distribution system to more than 60 °C for 1 hour.
- (e) Working away from the calorifier, open each hot water outlet in turn to draw water at a moderate flow rate until the temperature is more than 60 °C, then reduce the flow and maintain a low flow at more than 60 °C for 5 minutes. If the hot water demand of this process exceeds the calorifier's capacity, the tap flushing should be suspended until the calorifier is hot again and then resumed.
- (g) Once the flushing is complete, return the thermostat and shunt pump settings to normal.

Calorifiers should also be constructed with easy access for inspection, draining, dismantling and cleaning. A large drain or dump valve at the lowest point is required to facilitate rapid draining and removal of sludge.

Scalding

The risk of scalding at temperatures below 48 °C is low for most people (although the very young, very old or infirm might still be at a significant risk, see below) but rises rapidly above 50 °C, particularly for prolonged exposure and is considerably greater for whole body immersion than hand exposure. Caution is needed to prevent excessive temperatures at the tap, and warning notices (pictorial and internationally understood) should be posted at known risk areas. Where scald protection is required, it should be provided by blending hot and cold water rather than operating the hot water system below the temperatures specified (see above). This should be clearly differentiated in the scheme of control as 'mixed water' which is distinct from 'hot water', which has to be, by definition, 60 °C during storage and 55–60 °C (minimum 50 °C) elsewhere.

Certain areas in hospitals and other healthcare premises, such as residential care homes for the elderly, nurseries, baby changing facilities, etc., present a higher risk of scalding because of the higher susceptibility of the users and should be fitted with fail-safe thermostatic mixing valves (TMVs) type 3 (TMV3, see below) to blend hot water to safe temperatures where there is total body immersion, as in baths and showers.

The mixed water downstream of TMVs provides an environment in which legionellae can multiply and where TMV3s are used, there is no means of thermal disinfection. Note that type 2 TMVs can be overridden and the hot water can then be used for disinfection of the mixed water pipework and fitting. Mixed water pipe runs should be kept

as short as practicable, generally with one TMV serving each outlet or set of immediately adjacent outlets. It will usually be possible to keep mixed water pipe runs to about 1 m and they should be no longer than 2 m for an individual installation or 3 m in total where one TMV serves more than one outlet (e.g. where there are two outlets fed by one TMV, each spur should be no more than 1.5 m so the total is no more than 3 m). Further information can be gained from Building Regulations requirements for dwellings: the Building Regulations 2000 Approved Document G (DCLG, 2010) for England and Wales, and Scottish Building Standards Domestic Technical Handbook Section 4 (BSDSG, 2011) for Scotland.

The 'hot' water supply temperature to a bath (or, in Scotland, to a bath, bidet or shower in a non-domestic building, or a bath or bidet in a domestic building) should be limited to a maximum of 48 °C by use of an in-line blending valve or other appropriate temperature control device, with a maximum temperature stop and suitable pipework arrangement. This can be achieved with the use of a TMV2.

Note that TMV type 3 (TMV3) meets the requirements of the NHS Estates Model Engineering Specification (MES) D08 – *Thermostatic mixing valves (healthcare premises)* (NHS, 1997) and cannot be overridden by the user.

TMV type 2 (TMV2) meets the requirements of BS EN 111:2003 and/or BS EN 1287:1999 and can be overridden by the user.

For the situations where users are at greater than average risk of scalding (usually only young children, the elderly, the disabled or those people with sensory loss), the temperatures specified in the guidance for healthcare premises should be taken as a guide, bearing in mind the risk factors particular to each application and that these might differ from those in healthcare premises. The suggested maximum settings for total body immersion are:

- paediatric baths: 40 °C
- baths: 43 °C (however, up to 46 °C may be required, depending on the cold mass of the bath, but the water temperature will need to be checked by the nursing staff)
- showers: 41 °C
- bidets: 38 °C.

The widespread installation of failsafe TMV3s on wash hand basins in healthcare facilities makes the colonisation of outlets difficult to control. In reality, the chances of a severe scald from a wash basin tap are small and the need for a TMV3 on a wash hand basin should be assessed against the need for *Legionella* control.

It should also be noted that TMV3 taps are factory tested with water and, unless the manufacturer sterilises the tap after testing or takes other equally effective precautions, the new tap can contain several millilitres of water and be contaminated on arrival. Therefore they need to be disinfected at the time of installation. The manufacturer's instructions for disinfection should be followed. This may involve flushing the outlet with water at 70 °C for several minutes or even at 80 °C.

Note that there are no commonly accepted guidelines for temperature of water from sink taps. A temperature of 50–60 °C is needed for thorough removal of grease and for disinfection of crockery, etc. but, if the sink is likely to be used by a susceptible user, consideration should be given to means of reconciling the conflicting risks, for example by use of a TMV2 to deliver mixed water for general use, which can be overridden when hot water is required.

In buildings with especial risk factors, or those with susceptible occupants (for example, hospitals and healthcare premises), the potential risk of reverse flow through the return circulation pipework under draw-off can be minimised by fitting a non-return valve on the return leg of the hot water system, between the circulation pump and the calorifier. The cold feed to the calorifier should also be protected as described above.

To achieve the design outlet temperature, account should be taken of the extent of the distribution system, the actual storage temperature, the design temperature drop in the circulating water, the heat losses from the pipework and the demand pattern itself. Pipework should be designed to avoid deadlegs and long runs from which there is only occasional draw-off. Storage volumes and recovery rates should be designed to match the demand pattern without any drop in the supply temperature.

The traditional means of maintaining water temperatures in hot water services distribution systems and minimising water wastage is the provision of a flow and return, thermally insulated pipework system and a circulating pump. The pump performance is selected to offset the heat losses from the distribution pipework circuit and the consequential temperature drop, for example a 5 °C drop from a storage temperature of 60 °C would produce a return temperature of 55 °C. The minimum acceptable return temperature is 50 °C, so the greatest acceptable temperature drop is 10 °C, but most systems are capable of operating with drops of 5 °C or less. The water volume circulated by the pump is generally quite small, and with the return pipework sized for flow velocities of 1–1.5 m/s, the temperature drop in the return pipework is minimal.

As an alternative to a pumped circulation flow-and-return pipework system, a 'flow only' distribution system, sometimes called a 'dendritic system', can be used and this is common in small buildings. In large buildings with dendritic systems, significant volumes of water are likely to be cooler than 50 °C for much of the time between one use of a tap and the next. Flush times required to achieve hot (i.e. at least 50 °C) water may be longer than many users are willing to wait, so such a configuration is, by its nature, likely to present a higher *Legionella* risk than a circulating system. One solution is the use of electric trace heating fitted under the thermal insulation, and proprietary trace heating products are available that employ temperature self-regulation. However, as water from the taps is hot and mixed water from TMVs and showers is comfortable, this technique can lead to considerable risk of low temperature in calorifiers going unnoticed, so more frequent checks (weekly rather than monthly) are required.

Consideration should be given to the energy efficiency of electrical trace heating versus pumped flow-and-return. When choosing and installing any trace heating system, consideration should be given to its long-term reliability and ease of replacement in case of failure.

Design considerations for non-recirculating (dendritic or branched) HWS systems serving small premises are given in Section 5.4.

5.3.3 Operation and maintenance

The temperature regime is the conventional method of *Legionella* control in hot water systems, with storage as close to 60 °C as practicable without being any lower; distribution at 55–60 °C (50 °C minimum) throughout; scald protection by blending with appropriate thermostatic mixing valves only where an assessment of the scald risk indicates them to be necessary; and minimal mixed water pipe runs.

Once a year, operational staff should check that the outlet flow temperature of the stored hot water does not fall below 60 °C during normal operation. A temperature probe installed on the outlet of the calorifier can provide continuous monitoring when used in conjunction with the building management system (BMS).

Measuring the rate of cooling when the system has been turned off can be used to check the integrity of the thermal insulation. Typical temperature records, taken when the plant is known to be in good condition, should be recorded in the log book.

Where duplicate pumps are fitted, there should be non-return valves to prevent water from cycling round the pipework connecting the two pumps rather than round the building and operation of the pumps should change over frequently, at least weekly and preferably more often, taking care to ensure that no unintended risk is created. For example, a 12-hour changeover frequency

might result in one pump always running during the working day and the other only at night when the system is not heated, whereas alternating evenly might lead to both pumps wearing out in quick succession, quite possibly requiring the same part for repair.

Maintenance should include examination of hot water shower points or spray-type draw-off points that are connected to the central system, particularly at infrequently used outlets. Consideration should be given to removing any draw-off points that are used only rarely, otherwise these need to be run at frequent intervals. Whenever taps or other terminals are removed, the associated supply piping should also be removed at source, replacing tees with elbows or straights wherever possible, rather than leaving a blanked-off stub.

Regular cleaning, de-scaling and de-sludging of calorifiers should be carried out. A dump valve, installed close to the base of the calorifier, should be available to permit rapid draining. Calorifiers should be inspected internally every year (or more frequently where the deposits are heavy, as in hard water areas) and, when necessary, cleaned to remove scale and sludge.

An example hot water services system is illustrated in Figure 13, with notes on good practice given in Table 6.

Temperature checks should be carried out on the supply and each return leg of the hot water system. The supply temperature should be 60 °C and the return temperature not less than 50 °C, preferably 55 °C and checks should be carried out at a time when there is no hot water demand to draw hot water through the flow legs, which could result in readings being higher than they would otherwise be. Water temperatures should reach at least 50 °C and preferably 55–60 °C within a few seconds (and no more than 1 minute) of turning on the tap. Where these temperatures are not reached, the calorifier, pipework and thermal insulation should be investigated for potential heat losses and cross-flow from the cold

Table 6 Hot water services system good practice

1	Tight-fitting cistern cover to protect from dirt ingress; any vents should be screened.
2	Cold feed drawn from the side of the cistern to minimise dirt entrainment.
3	Cistern location and environment to minimise risk of excessive water temperatures.
4	Calorifier shell design to minimise scope for entrapped sludge; access to be adequate to permit inspection, cleaning and de-scaling.
5	Drain to be easily accessible and large enough to facilitate removal of sludge.
6	Heater to have capacity to maintain 60 °C in normal use and to be capable of heating calorifier and system water to more than 60 °C.
7	Thermostat setting to be correct (i.e. as close to, but not less than, 60 °C at outlet of calorifier) and checked regularly against the actual water storage temperature; a record should be kept.
8	Pump performance (or trace heating output) and pipework installation, including thermal insulation, to be designed to ensure minimum system water temperature of 50 °C; thermal insulation to be checked regularly for integrity.
9	Where duplicate pumps are provided, an automatic changeover procedure should be used; non-return valves should be fitted to prevent hot water cycling round the circulation pump manifold and to prevent reverse flow. In buildings with high-risk occupants a single pump should be installed with a spare held in readiness in case of breakdown and there should be a non-return valve to prevent reverse flow.
10	Shunt pump to operate when system is not in use to pasteurise the whole vessel; non-return valve to prevent backflow.
11	Open vent directed away from the cistern via a tundish and air gap. Water should not discharge through this pipe during normal operation.
12	Deadlegs to be eliminated wherever practicable and, where practicable, remove any draw-offs that are used rarely. Washers, jointing materials, etc. to be selected from the <i>Water Fittings and Materials Directory</i> (WRAS, 2005) approved list. All components to be provided with manufacturers' instructions for operation and maintenance, including cleaning; instructions to be implemented.

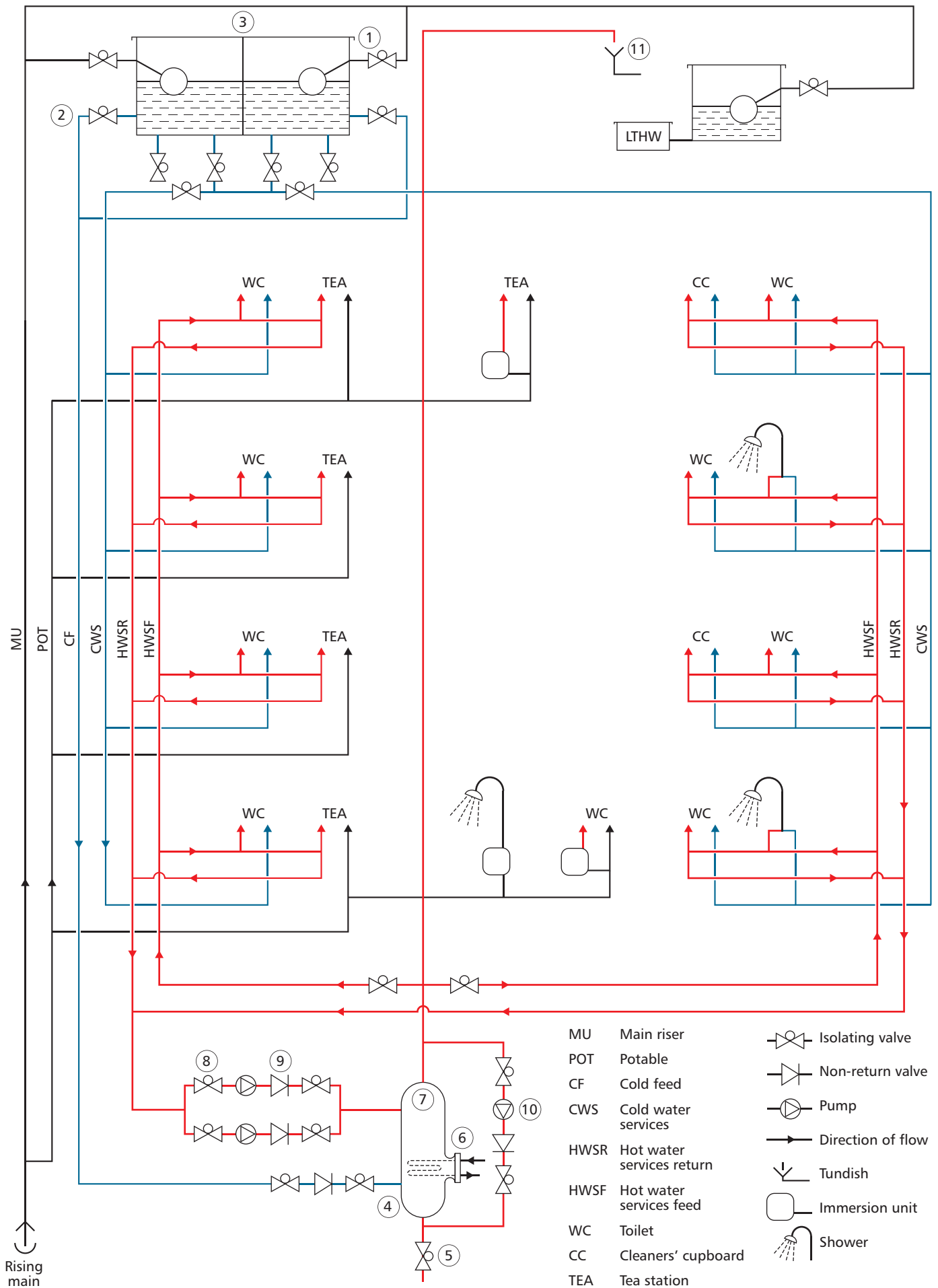

Figure 13 Example hot water system for a large office (For notes see Table 6)

Table 7 Recommended monitoring (M), inspection (I) and servicing (S) frequencies for hot and cold water services

System/service	Task	Frequency	Action
Hot water services	Check flow and return water temperatures at calorifiers	Monthly	M
	Check water temperature at the end of each return leg at a time of no hot water demand to see if they are at a minimum of 50 °C	Monthly	M
	Visual checks of internal surfaces of calorifiers for scale and sludge. Clean as needed and disinfect/pasteurise prior to re-introduction	Annually	I
	Check the temperature after 30 seconds' running at hot taps at all locations on a rota	Annually	M
Cold water services	Check tank water temperature remote from float-operated valve and mains temperature at float-operated valve. Note maximum temperatures recorded by fixed max/min thermometers, where fitted	Summer and winter	M
	Check that water temperature is below 20 °C at the sentinel taps after running the water for 2 minutes	Monthly	M
	Visually inspect cold water storage cisterns and carry out remedial work where necessary	Annually	I
	Check the temperature after 2 minutes' running at cold taps at all locations on a rotational basis	Annually	M
Shower heads and hoses	Dismantle, disinfect, clean and de-scale shower heads and hoses	Quarterly or as necessary	S
Little-used outlets	Flush little-used outlets	Twice weekly where users are at high risk: weekly in all other buildings	S

water system. If it is not practicable to reduce heat losses, electric trace heating with thermal insulation can be used to maintain adequate temperatures, with additional (at least weekly) monitoring of the temperature of the calorifier or hot water outlet.

Shower heads should be dismantled, disinfected and cleaned sufficiently frequently to ensure negligible build-up of deposits. Taps with flow straighteners or aerators should be inspected at appropriate intervals and the inserts removed and cleaned. TMVs should be maintained in accordance with the manufacturer's instructions and checked annually.

If a calorifier or any substantial part of the hot water system is on standby use or has been taken out of service for longer than one week (for example, for maintenance), then the affected parts should be pasteurised before the system is brought back into service.

5.3.4 Monitoring

The supply temperature at the outlet of the calorifier should be checked monthly, and should not be lower than 60 °C; the return temperature should also be checked monthly and should not be lower than 55 °C (50 °C as an absolute minimum).

All subsidiary loops of the hot water system (e.g. in each riser, around each floor or facility) should be located and the direction of flow determined. Monthly temperature checks should be made at the end of each return leg at a time of no hot water demand to confirm that the flow through all loops is balanced; the temperature should be no less than 55 °C. If it proves difficult to obtain accurate hot water return temperature readings with contact probes, thermocouples could be placed permanently on pipework inside the insulation, with wires protruding to be connected to a hand-held instrument or BMS. Where

return legs are inaccessible, the last tap on the loop may be used as a temperature monitoring point, but it must be borne in mind that this will not detect low flow or static loops, as hot water may be drawn through to the tap (via either the flow or return leg). Consideration should be given to gaining access to fit thermocouples on the return legs with wires leading to accessible points where they can be plugged into instruments for subsequent monitoring.

When using temperature as a control regime, the checks listed in Table 7 should also be carried out, and appropriate remedial action taken if necessary.

Periodically, but at least every two years, the hot water system should be surveyed physically to ensure that the schematic diagram on record is still current. The procedures for bringing standby pumps and other equipment into operation should be checked annually.

Infrequently used taps or parts of the system should be flushed weekly.

5.4 Small-scale, non-recirculating HWS systems

5.4.1 General

The provision of recirculating HWS systems for premises such as small retail, commercial or industrial businesses, public houses, guest houses and private hotels may not be justified for reasons of cost. In retail, commercial and industrial applications, typically the durations of exposure will be small and the susceptibility of individuals average.

5.4.2 Design

Depending on the building layout, it may be feasible to keep the layout of the system sufficiently compact to ensure that draw-off outflows reach 50 °C within a few seconds of opening the outlets.

Another option that should be considered is the installation of point-of-use water heaters.

Where existing buildings with non-recirculating systems are known to have outlets where the outflow temperature and time requirement cannot be met, the appropriate optimal modification will depend on the particular circumstances. Ensure that the risk assessment has taken such systems into consideration and included them in the written scheme of routine/remedial works.

5.4.3 Operation and maintenance

The recommendations given in Section 5.3.3 apply.

5.4.4 Monitoring

The recommendations given in Section 5.3.4 apply.

5.5 Microbiological testing

There is potential for micro-organisms to proliferate in various parts of hot and cold water systems. Unlike cooling towers and spa baths, there is no requirement to carry out routine total viable count (TVC) testing, although it can be undertaken for other water quality purposes and provides useful information on system performance/cleanliness as part of more comprehensive system audits. If there is evidence of microbiological growth, however (i.e. from the colour, taste or odour of the water), it needs to be investigated as this could include the presence of *Legionella*.

It is recommended that monitoring for *Legionella* be carried out:

- when there is evidence that the system has become contaminated
- if a system is suspected of causing a case of legionellosis
- when control levels for the system (i.e. temperature, biocide, regular usage) are not being consistently achieved
- in instances where the control regime for a hot water system involves maintaining a lower temperature, to save energy, in conjunction with use of a biocide.

These systems should initially be monitored for *Legionella* monthly for at least for the first year, after which the frequency of testing can be reviewed if the efficacy of the biocide regime has been demonstrated.

Samples should be taken as follows:

- *cold water system*: from the cold water storage tank and the furthest outlet from the tank. Samples may also be required from outlets in areas of particular concern, e.g. in hospital wards with 'at risk' patients
- *hot water system*: from the calorifier outlet or the nearest tap to the calorifier outlet plus the return supply to the calorifier or nearest tap to that return supply. Samples should also be taken from the base of the calorifier where drain valves have been fitted. The furthest outlet from the calorifier should also be sampled. Samples may also be required from outlets in areas of particular concern, e.g. in hospital wards with 'at risk' patients.

When the risk assessment identifies that samples should be taken, the complexity of the system will need to be taken into account to determine the appropriate number of samples. In order to be indicative of the system as a whole, samples should be taken from outlets representative of the circulating water and not taken from temporarily stored water, e.g. at TMV-controlled taps and showers. It may be appropriate during the risk assessment process/review to take samples downstream of TMVs, through shower hoses and at mixer taps/blended water outlets to provide information on whether the frequency of de-scaling, cleaning and disinfection has been effective at minimising the risk of colonisation.

Testing of samples for *Legionella* should be performed in laboratories accredited to BS EN ISO/IEC 17025:2005 with current ISO standard methods for the detection and enumeration of legionellae included within their scope of accreditation. These methods can be for detection and enumeration of *Legionella* by culture for viable cells or by a validated and accredited qPCR method (refer to Section 3.6). The identification of *Legionella* requires skill and practice and should therefore be carried out by experienced microbiologists. Interpreting the results, once confirmed by the laboratory, and relating them to the risk of legionellosis requires knowledge of the system and the skills of a risk assessor.

Table 8 gives guidance on action to be taken if *Legionella* is found in the water system.

Table 8 Action to be taken on discovery of *Legionella*

<i>Legionella</i> bacteria (cfu/l)	Action required
More than 100 but less than 1000	Either: (a) If only one or two samples are positive, system should be re-sampled. If a similar count is found again, a review of the control measures and risk assessment should be carried out to identify any remedial actions necessary. (b) If the majority of samples are positive, the system may be colonised, albeit at a low level, with <i>Legionella</i> . Disinfection of the system should be considered but an immediate review of control measures and risk assessment should be carried out to identify any other remedial action required.
More than 1000	The system should be re-sampled and an immediate review of the control measures and risk assessment carried out to identify any remedial actions, including possible disinfection of the system.

5.6 Flushing

The risk from *Legionella* growing in peripheral parts of a domestic water system, such as remote outlets and deadlegs off the recirculating hot water system, may be minimised by regular use of these outlets. When outlets are not in regular use, weekly flushing of these devices for several minutes can significantly reduce the number of *Legionella* discharged from the outlet. To ensure that the outlets have been flushed properly, continue to flush until the temperature at the outlet stabilises and is comparable to supply water. Once started, this procedure has to be sustained and logged, as lapses can result in a critical increase in *Legionella* at the outlet.

Risk assessment may indicate the need for more frequent flushing where there is a more susceptible population present, such as in hospitals, nursing homes, etc.

Where it is difficult to carry out weekly flushing, the stagnant and potentially contaminated water from within the shower or tap and associated deadleg needs to be purged to drain before the appliance is used. It is important that this procedure is carried out with minimum production of aerosols, e.g. additional piping may be used to purge contaminated water to drain.

Automatic drain valves, fitted to showers to drain the mixer valve and shower hose after use, can produce

conditions within the shower that support the growth of *Legionella* and are not recommended as a method for controlling the risk of exposure.

6 Spa pools, whirlpool spas and whirlpool baths

6.1 Introduction

Spa pools (or whirlpool spas) are increasingly popular in sports centres, health resorts, long-term healthcare facilities and hotels. They are currently the third most common cause of legionellosis in the UK. There have also been a number of significant outbreaks caused by spa pools on display as well as those in normal use.

A spa pool is a self-contained body of warm water designed for sitting in as opposed to swimming. There is usually a mechanism for circulating water and air around the user, and the pool is maintained at a temperature of 32–40 °C. The pool is not drained or refilled after each user but, instead, the water is filtered, treated with disinfectant and recirculated.

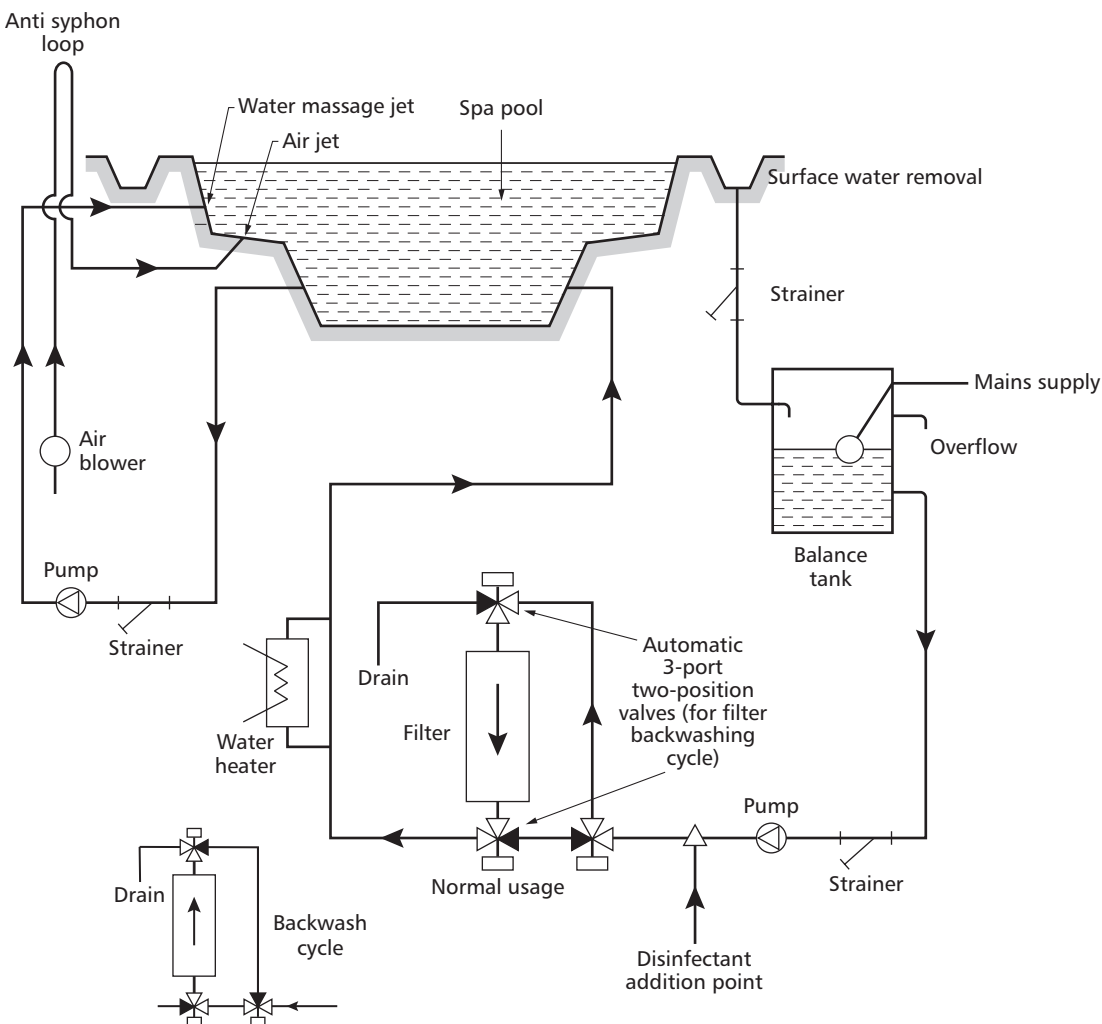

Figure 14 Schematic diagram of a typical spa system

The relatively small volume of water in relation to the number of users, combined with the raised temperature, agitation and aeration of the water, makes spa pools potentially ideal environments for the growth of micro-organisms, including *Legionella*. The splashing of the water and the bubbling create an aerosol immediately above the surface of the water at a level where it is readily inhaled by the bathers.

6.2 System management

A schematic diagram of a typical spa pool system is shown in Figure 14. The Responsible Person and staff responsible for the maintenance of the pool must have received a thorough training in the management of spa pools. The spa should be designed so that the pipework can be drained completely and is accessible for disinfection and cleaning to ensure physical removal of all biofilms. Pools are designed for a particular occupancy, which is stated by the manufacturer and should not be exceeded.

Method statements, escalation procedures and relevant training need to be included as part of the management procedures for spa pools. *The management of spa pools: Controlling the risks of infection* (HPA/HSE, 2006), published jointly by the UK Health Protection Agency and the Health and Safety Executive, provides comprehensive information on developing and implementing schemes of management for these systems.

The preferred disinfectants for spa pools are chlorine or bromine but other biocides may also be used (the term 'biocide' is sometimes used in place of 'disinfectant'). Both chlorine and bromine require the pH of the water to be controlled. Chlorine requires two-stage testing to measure the active free chlorine and the less active combined chlorine, which is also irritating to the eyes. Methods for testing and detailed guidance on the design and operation of spa pools can again be found in *The management of spa pools: Controlling the risks of infection* (HPA/HSE, 2006), from which the following summary has been taken.

Daily before opening the spa pool:

- check water clarity before first use
- check that automatic dosing systems are operating (including ozone or UV lamp if fitted)
- check that the amounts of dosing chemicals in the reservoirs are adequate
- measure the pH value of the spa pool water (desired result 7.0–7.6)
- measure the disinfectant concentration:
 - where chlorinating disinfectants are used, a free chlorine level of 3–5 mg/l should be maintained in the spa pool water; the ideal combined chlorine concentration is nil, however concentration of less than 1 mg/l is normally considered acceptable

- where bromine is used as a disinfectant, 4–6 mg/l of total active bromine should be maintained in the spa pool water; free and combined bromines are not usually differentiated between when monitoring, since combined bromine is an effective disinfectant.

Throughout the day:

- continue to check that automatic dosing systems are operating (including ozone or UV lamp if fitted)
- determine the pH value and residual disinfectant concentration of the spa pool water every 2 hours
- determine the total dissolved solids, where appropriate.

At the end of the day, after closing the spa pool:

- clean water-line, overflow channels and grills
- clean spa pool surround
- backwash sand filter (ensure water is completely changed at least every 2 days); for diatomaceous earth or other precoat filters comply with the manufacturer's instructions
- inspect strainers, clean and remove all debris if needed
- record the throughput of bathers, unless water is being changed continuously
- record any untoward incidents.

At least weekly and at every drain and refill:

- drain and clean whole system, including balance tank
- clean strainers
- check water balance after the refill, if necessary
- if covers are used, clean inside and out using a solution of 10 mg/l of free chlorine
- remove the headrests and clean the areas behind.

Monthly:

- carry out microbiological tests for indicator organisms: aerobic colony count (sometimes called the total viable count (TVC) or plate count), coliforms, *Escherichia coli* and *Pseudomonas aeruginosa*:
 - the aerobic colony count should normally be ten or fewer colony forming units per millilitre (cfu/ml) of spa pool water
 - the presence of coliforms indicates that the treatment has failed to remove this contamination. Coliforms are sensitive to disinfectant and should be absent in 100 ml of spa pool water
 - *E. coli* should be absent in a 100 ml sample. However, because most bathers will have some faecal contamination of their skin, particularly if they have not

Table 9 *Legionella* sampling and interpretation

<i>Legionella</i> colony forming units per litre (cfu/l) of spa pool water	Interpretation and action
<10 ² (less than 100)	Under control, no action required*
10 ² –10 ³ (100 to 1000)	Re-sample and keep under review Advised to drain, clean and disinfect Review control and risk assessment; carry out remedial actions identified Refill and retest next day and 2–4 weeks later
>10 ³ (more than 1000)	Immediate closure. Exclude public from pool area Shut down spa pool Shock the spa pool with 50 mg/l effective free chlorine circulating for 1 hour or equivalent Drain, clean, refill and disinfect Review control and risk assessment; carry out remedial actions identified Refill and retest next day and 2–4 weeks later It may be advisable to alert the local Health Protection Unit Keep closed until <i>Legionella</i> is not detected and the risk assessment is satisfactory

* Note: Sampling and analysis, however, is not and cannot be a substitute for control, neither is any result, whether positive or negative, directly related to the risk to health, as discussed in Section 2, so any *Legionella*-positive result should be given serious consideration as it usually indicates a failure of control, even though the direct risk may not be great.

showered before bathing, a single positive sample may be the result of recent superficial contamination by a bather that has not yet been decontaminated by the disinfectant residual. A repeat sample should then be taken

- well-operated spa pools should not normally contain *P. aeruginosa*. If the count is over 10 *P. aeruginosa* per 100 ml, repeat testing should be undertaken. Where repeated samples contain *P. aeruginosa*, the filtration and disinfection processes should be examined to determine whether there are areas within the spa pool circulation where the organism is able to multiply. There is a risk of an outbreak of folliculitis when the count exceeds 50 cfu/100 ml so the spa pool should be closed, remedial action taken and the water re-sampled

- undertake a full chemical test (optional)
- clean input air filter when fitted
- inspect accessible pipework and jets (and pipework behind them) for presence of biofilm; clean as necessary
- check that the residual current circuit breaker/earth leakage trip is operating correctly
- check all automatic systems are operating correctly, e.g. safety cut-outs, automatic timers, etc.
- disinfectant/pH controller: clean electrode and check calibration (in accordance with the manufacturer's instructions).

Quarterly:

- thoroughly check sand filter or precoat filter membranes
- where possible, clean and disinfect airlines
- take water sample and test for *Legionella* by an accredited laboratory (see Table 9 for interpretation of results).

Annually:

- check that all written procedures are correct
- check sand filter efficiency.

Since spa pools usually have hydrojet circulation, air induction bubbles or some combination or variation of these, they are also often known as whirlpool spas. In contrast, a whirlpool bath is a bath, usually a personal one, fitted with high-velocity water jets and/or air injection, which incorporates water recirculation. The water is not chemically treated and is discharged after each use. Whirlpool baths are increasingly being installed in healthcare facilities and hotels. They probably do not present the same degree of hazard as spa pools, and no incidents have been reported that link whirlpool baths with Legionnaires' disease.

However, concern has been expressed because they do become readily colonised with *Pseudomonas aeruginosa*, another potential pathogen, and this colonisation is often difficult to remove, even with superchlorination. All of the requirements in Section 5.3 for hot water services apply to whirlpool baths, and particular care is needed to disinfect after each use and to clean and disinfect any concealed recirculating water piping regularly. Improved methods of disinfecting whirlpool baths are being investigated.

7 Other possible risk areas

As *Legionella* may occur in almost any water supply, very many systems or installations containing water have the potential to be a source of risk, so it would be impracticable in a memorandum such as this to draw up a list of all potential sources of risk or to devise specific schemes of control for every type of system under all circumstances. A list of the other main at-risk systems is given in Section 1.1.

What all systems do have in common, however, and what can be addressed in general terms, is that the chain of events that creates the risk is always the same. Thus an understanding of the configuration, operation and condition of any system can be used, in combination with an understanding of the principles of *Legionella* risk assessment and control, to assess the risk and to devise appropriate schemes of control.

7.1 Risk assessment

BS 8580:2010 identifies a chain of five events that can lead to the potential for Legionnaires' disease occurring:

- (1) The water system needs to become contaminated (inoculated) with the bacteria.
- (2) Conditions have to exist within the system for the colonisation and amplification of the bacteria to sufficient concentrations to cause infection (i.e. temperature, stagnation).
- (3) The contaminated water usually needs to be dispersed into droplets fine enough to form an aerosol.
- (4) Inhalation of contaminated aerosols or, in rare cases, aspiration of contaminated drinking water.
- (5) The exposed individual has to be susceptible to succumb to infection.

These can be used as the basis of a risk assessment for any water system. However, there is an additional element which should be addressed:

- (6) The scheme of *Legionella* control, in particular its robustness.

Expanding the first of these principles — inoculation with the bacteria — the assessment should consider the source of the water with respect to the likelihood of *Legionella* contamination and its likely level. For example:

- mains water may contain minute concentrations of *Legionella*, sufficient to seed a system, but not to constitute a direct risk of infection to any but the most vulnerable, whereas
- untreated surface or groundwater may contain higher concentrations, and
- recovered grey water may contain high enough concentrations to present a direct risk.

Consideration also needs to be given to the likelihood of contamination in storage, transit and use. A cold water storage tank which conforms to British Standards and water regulation guidance would prevent most contamination, as would a copper distribution system, whereas open sumps and gullies are likely to contaminate the water to a greater extent.

Conditions in the system for the amplification of the bacteria include temperature (20–50 °C and especially 32–42 °C), a source of nutrient (whether from contaminants or materials of construction) and sufficient time to for numbers to increase.

Formation of an aerosol is generally by any or a combination of mechanisms:

- spraying or atomising water in an airflow
- striking a surface
- breaking a stream
- bursting bubbles
- cascading
- flinging off a surface.

Table 10 Scheme of control risk factor analysis

Risk factor	Possible precaution
The water system needs to become contaminated (inoculated) with the bacteria	Use a low-risk water source, such as the mains Apply water treatment to the water supply to reduce the incidence of <i>Legionella</i> contamination
Conditions have to exist within the system for the amplification of the bacteria to sufficient concentrations to cause infection	Maintain temperatures outside the incubation range Displace stagnant water with fresh water at a frequency which outpaces the amplification of <i>Legionella</i> under the conditions in the system Apply water treatment to the system water to inhibit the amplification of <i>Legionella</i>
The contaminated water usually needs to be dispersed into droplets fine enough to form an aerosol for transmission to the victim(s)	Modify components or processes to reduce the formation of aerosols
Inhalation of contaminated aerosols or, in rare cases, aspiration of contaminated drinking water	Modify processes or installations to reduce dissemination of aerosols Minimise personal exposure by avoiding exposure at times when the aerosol is present (or at its most dense), reducing duration of contact
The exposed individual has to be susceptible to succumb to infection	Where it is practicable to control those exposed, avoid exposing those with known susceptibility characteristics Apply controls more stringently where the exposed population has known susceptibility characteristics

Assessment of the risk from inhalation of aerosols should consider the degree of exposure, which includes both density and duration. The number of people likely to be exposed should also be taken into account.

The risk of acquiring Legionnaires' disease from aspiration is low for normally healthy people. Those with an inhibited swallow reflex or who may drink water while lying down (for example, people in hospital) are at increased risk.

Susceptibility factors are well-documented elsewhere and include age, smoking and medical conditions which reduce the body's immune capability.

7.2 Scheme of control

The process of risk assessment is a logical analysis of the factors that generate a risk of legionellosis, and considering each in turn provides a framework for devising a scheme of control. It should be remembered when going through this process that any line of reasoning which concentrates on the stages of a process at the expense of an overall view is likely to create anomalies, so there also needs to be an overview to ensure that the scheme devised is both comprehensive and proportional.

The scheme of control and its robustness make the difference between an uncontrolled, perhaps substantial, risk and a controlled, acceptable risk, but it can only be effective if it is implemented by fully trained and competent individuals and overseen by active management, with non-compliances addressed and faults corrected in a timely manner.

Table 10 gives some examples of how the risk factors may be used to devise elements of a scheme of control.

In assessing the robustness of the scheme, consider the following:

- whether the precautions are capable of reducing the risk to an acceptable level
- whether all elements of the scheme are assigned to competent individuals

- whether the precautions have been implemented
- whether non-compliances arising from routine checks have been identified and considered
- whether faults have been identified and considered
- whether the corrective action for non-compliances and faults is sound and proportionate.

8 Conclusions and further information

Engineers must accept that some *Legionella* will probably be present in nearly all water systems. The task is to prevent multiplication, production of an aerosol and inhalation of water droplets. Particular care is needed in buildings that contain susceptible people, for example hospitals and homes for the elderly. Building water systems and services will also continue to grow and evolve, for which assessments of risk, schemes of management and effective control will be required.

This publication has set out to provide good practice guidance to those involved in the design, installation, commissioning, operation and maintenance of water services susceptible to *Legionella* contamination. Where these guidelines are followed then the risk of infection will be minimised.

The Appendices that follow provide further detail on a range of issues:

- a glossary of terms is provided in Appendix A1
- an emergency cleaning procedure for cooling towers and hot and cold water systems is provided in Appendix A2
- guidance for suspected outbreaks of Legionnaires' disease is provided in Appendix A3
- an outline system checklist for the more common systems encountered is provided in Appendix A4
- international regulations, standards and guidance are detailed in Appendix A5.

References

- Anon (1987) 'Community-acquired pneumonia in adults in British hospitals in 1982–1983: A survey of aetiology, mortality, prognostic factors and outcome' *Quarterly Journal of Medicine*, 62: 195–220
- Association Française de Normalisation (AFNOR) (2010) NF T90-471: *Qualité de l'eau – Détection et quantification des Legionella et/ou Legionella pneumophila par concentration et amplification génique par réaction de polymérisation en chaîne en temps réel (RT-PCR)* (www.boutique.afnor.org)
- Building Standards Division of the Scottish Government (BSDSG) (2011) *Technical Handbook 2010 — Domestic Handbook (Section 4)* (London: TSO)
- Chartered Institution of Building Services Engineers (CIBSE) (1995) *CIBSE Technical Memoranda TM20: Health, safety and welfare in the built environment* (London: CIBSE)
- (2002a) *CIBSE Technical Memoranda TM13: Minimising the risk of Legionnaires' disease* (London: CIBSE)
- (2002b) *CIBSE Commissioning Code R: Refrigerating systems* (London: CIBSE)
- (2004) *CIBSE Guide G: Public health engineering* (London: CIBSE)
- (2010) *CIBSE Commissioning Code W: Water distribution systems* (London: CIBSE)
- Department for Communities and Local Government (DCLG) (2010) *Sanitation, hot water safety and water efficiency: Approved Document G* (NBS: Newcastle upon Tyne)
- Department of Health Estates and Facilities Division (2006) *HTM 04-01 The control of Legionella, hygiene, 'safe' hot water, cold water and drinking water systems (Part A and Part B)* (London: TSO)
- Gaia V, Fry N K, Afshar B, *et al.* (2005) 'Consensus sequence-based scheme for epidemiological typing of clinical and environmental isolates of *Legionella pneumophila*' *Journal of Clinical Microbiology*, 43: 2047–2052
- Health and Safety Executive (HSE) (2000) *Approved Code of Practice and Guidance (ACoP) L8: Legionnaires' disease – the control of legionella bacteria in water systems* (Sudbury: HSE Books)
- (2001) *Health and safety in care homes (HSG220)* (Sudbury: HSE Books)
- (2012) *Legionnaires' disease: A brief guide for dutyholders* (Leaflet INDG458) (Sudbury: HSE Books)
- Helbig J H, Luck P C, Knirel Y A, Witzleb W and Zahringer U (1995) 'Molecular characterization of a virulence-associated epitope on the lipopolysaccharide of *Legionella pneumophila* serogroup 197' *Epidemiology and Infection*, 115: 71–78
- Health Protection Agency/Health and Safety Executive (HPA/HSE) (2006) *The management of spa pools: Controlling the risks of infection* (London: Health Protection Agency)
- Joseph C A and Ricketts K D (2010) 'Legionnaires disease in Europe 2007–2008' *Eurosurveillance*, 15(8): 19493
- Lee J V, Surman S B, Hall M and Cuthbert L (2002) 'Development of an international EQA scheme for the isolation of *Legionella spp.* from environmental specimens' in Marre R, Abu Kwaik Y, Bartlett C *et al.* (eds) *Legionella* (Washington DC: ASM Press), pp. 271–274
- Lee J V, Lai S, Exner M, *et al.* (2011) 'An international trial of quantitative PCR for monitoring for *Legionella* in artificial water systems' *Journal of Applied Microbiology*, 110: 1032–1044
- Lim W S, Macfarlane J T, Boswell T C, Harrison T G, Rose D, Leinonen M and Saikku P (2001) 'Study of community acquired pneumonia aetiology (SCAPA) in adults admitted to hospital: Implications for management guidelines' *Thorax*, 56: 296–301
- National Health Service (NHS) (1997) *Model Engineering Specification (MES) D08: Thermostatic mixing valves (healthcare premises)* (London: TSO)
- Nguyen T M, Ilef D, Jarraud S, *et al.* (2006) 'A community-wide outbreak of legionnaires disease linked to industrial cooling towers: How far can contaminated aerosols spread?' *Journal of Infectious Diseases*, 193: 102–111
- Parthuisot N, West N J, Lebaron P, Baudart J (2010) 'High diversity and abundance of *Legionella spp.* in a pristine river and impact of seasonal and anthropogenic effects' *Applied and Environmental Microbiology*, 76(24): 8201–8210
- Ratzow S, Gaia V, Helbig J H, Fry N K and Luck P C (2007) 'Addition of neuA, the gene encoding N-acylneuraminatyltransferase, increases the discriminatory ability of the consensus sequence-based scheme for typing *Legionella pneumophila* serogroup 1 strains' *Journal of Clinical Microbiology*, 45: 1965–1968
- Water Management Society/British Association of Chemical Specialities (WMS/BACS) (1999) *The control of legionellosis: A recommended code of conduct for service providers* (Sutton: BACS)
- Water Regulations Advisory Scheme (WRAS) (2001) *Water Regulations Guide* (Oakdale: WRAS)
- (2005) *Water Fittings and Materials Directory* (Oakdale: WRAS) (regularly updated online: www.wras.co.uk/directory)
- World Health Organization (WHO) (2007) *Legionella and the prevention of legionellosis* (Geneva: WHO)

Standards

- BS 853-1:1996: *Specification for vessels for use in heating systems. Calorifiers and storage vessels for central heating and hot water supply* (London: BSI)
- BS 4485:(1969–1996) (4 parts): *Water cooling towers* (London: BSI)
- BS 4884:(1992–1993) (3 parts): *Technical manuals* (London: BSI)
- BS 4940:1994 (3 parts): *Technical information on construction products and services* (London: BSI)
- BS 6069-2:1994: *Characterization of air quality. Glossary* (London: BSI)
- BS 6068-4.12:1998 (ISO 11731:1998): *Water quality. Microbiological methods. Detection and enumeration of Legionella* (London: BSI)
- BS 6920-1:2000: *Suitability of non-metallic products for use in contact with water intended for human consumption with regard to their effect on the quality of water. Specification* (London: BSI)
- BS 7592:2008: *Sampling for Legionella bacteria in water systems. Code of practice* (London: BSI)
- BS 8580:2010: *Water quality. Risk assessments for Legionella control* (London: BSI)
- BS 8558:2011: *Guide to the design, installation, testing and maintenance of services supplying water for domestic use within buildings and their curtilages* (London: BSI)
- BS EN 111:2003 *Wall-hung hand rinse basins. Connecting dimensions* (London: BSI)

BS EN 806-1:2000: *Specifications for installations inside buildings conveying water for human consumption. General* (London: BSI)

BS EN 806-2:2005: *Specifications for installations inside buildings conveying water for human consumption. Design* (London: BSI)

BS EN 806-3:2006: *Specifications for installations inside buildings conveying water for human consumption. Pipe sizing. Simplified method* (London: BSI)

BS EN 806-4:2010: *Specifications for installations inside buildings conveying water for human consumption. Installation* (London: BSI)

BS EN 806-5:2012: *Specification for installations inside buildings conveying water for human consumption. Operation and maintenance* (London: BSI)

BS EN 1287:1999: *Sanitary tapware. Low pressure thermostatic mixing valves. General technical specifications* (London: BSI)

ISO 9001:2008: *Quality management systems – Requirements* (London: BSI)

ISO 11731-2:2004: *Water quality – Detection and enumeration of Legionella – Part 2: Direct membrane filtration method for waters with low bacterial counts* (London: BSI)

BS EN ISO/IEC 17025:2005: *General requirements for the competence of testing and calibration laboratories* (London: BSI)

PD ISO/TS 12869:2012: *Water quality – Detection and quantification of Legionella spp. and/or Legionella pneumophila by concentration and genic amplification by polymerase chain reaction (qPCR)* (London: BSI)

Legislation

Building Regulations 2010, Statutory Instrument 2010 No. 2214

Construction (Design and Management) Regulations 2007, Statutory Instrument 2007 No. 320

Control of Substances Hazardous to Health Regulations 2002, Statutory Instrument 2002 No. 2677

Corporate Manslaughter and Corporate Homicide Act 2007

Health and Safety at Work etc. Act 1974 (Chapter 37)

Health Protection (Notification) Regulations 2010, Statutory Instrument 2010 No. 659

Management of Health and Safety at Work Regulations 1992, Statutory Instrument 1999 No. 3242

Notification of Cooling Towers and Evaporative Condensers Regulations 1992, Statutory Instrument 1992 No. 2225

The Public Health (Notification of Infectious Disease) (Scotland) Regulations 1988, Statutory Instrument 1988 No. 1550 (S155). As amended by the Public Health (Notification of Infectious Diseases) (Scotland) Amendment Regulations 1989, Statutory Instrument 1989 No. 2250 (S149)

Registered Homes Act 1974

Reporting of Injuries, Diseases and Dangerous Occurrences Regulations 1995, Statutory Instrument 1995 No. 3163

Water Supply (Water Quality) Regulations 2010, Statutory Instrument 2010 No. 994 (W99)

Water Supply (Water Fittings) Regulations 1999, Statutory Instrument 1999 No. 1148

Bibliography

American Society of Heating, Refrigerating and Air Conditioning Engineers ASHRAE Standard 188P (2012): *Prevention of Legionellosis associated with building water systems* (Atlanta, GA: ASHRAE)

Armstrong J (1990) *Operating and maintenance manuals for building services installations*, BSRIA Application Guide AG1/87 (2nd edn) (Bracknell: BSRIA)

British Association of Chemical Specialities (1989, updated 1995) *The control of legionellae by the safe operation of cooling systems* (Sutton: BACS)

Building Services Research and Information Association (1988) *Commissioning HVAC systems: Division of responsibilities*, BSRIA Technical Memorandum TM1/88 (Bracknell: BSRIA)

— (1989) *The commissioning of water systems in buildings*, BSRIA Application Guide AG 2/89 (Bracknell: BSRIA)

— (1994) *Guide for legionellosis: Temperature measurements for hot and cold water services*, BSRIA Applications Guide AG4/94 (Bracknell: BSRIA)

Chartered Institution of Building Services Engineers (1986) CIBSE Guide Section B14: *Refrigeration and heat rejection* (London: CIBSE)

Health and Safety Executive (1996) *Prevention and control of legionellosis (including Legionnaires' disease)* Approved Code of Practice L8 (London: HMSO)

Hosker R P (1985) 'Flow around isolated structures and building clusters: A review' *ASHRAE Transactions*, 91(2)

Humphrey T J (1989) 'Microbial contamination of hospital showers and shower water, the effect of an automatic drain valve' *Journal of Hospital Infection*, 13: 55–61

Institute of Plumbing (1989) *Plumbing engineering services design guide* (Hornchurch: Chartered Institute of Plumbing and Heating Engineering (CIPHE))

— (1990) *Legionnaires' disease: Good practice guide for plumbers* (Hornchurch: CIPHE)

Medical Services Directorate (1993) *Ice cubes*, Hazard Note (93)42 (London)

National Engineering Specification (1987) (Milton Keynes: Amtech)

National Health Service Estates (1998) *'Safe' hot water and surface temperatures*, Health Guidance Note (London: HMSO)

Penwarden A D and Wise A F E (1975) *Wind environment around buildings*, Report (Garston, Building Research Establishment)

Thornberry C (ed.) (1984) *Legionella: Proceedings of the 2nd International Symposium of the American Society for Microbiology* (Washington: American Society for Microbiology)

Water Management Society (2008) *Cooling water treatment: A code of practice* (Tamworth: WMSoc)

— (2007) *Keeping your cooling tower safe* (Tamworth: WMSoc)

— (2012) *Understanding your cooling tower system water treatment service reports* (Tamworth: WMSoc)

Westminster Action Committee (1988) *Broadcasting House Legionnaires' disease* (London, Westminster City Council)

Wright A E (Chairman) (1989) *Report of the Expert Advisory Committee on Biocides* (London: Department of Health/HMSO)

Appendix A1: Glossary

acid

A chemical that reduces the pH of water and reacts with an alkali or base. Commonly used for removing scale and other deposits from systems, and sometimes as a scale inhibitor.

acidity

The concentration of acid in water (measured by titration with alkali: not proportional to pH).

adenosine triphosphate (ATP)

A chemical used as an energy source in cells for metabolic purposes. Its concentration in water can be used to estimate microbial population.

adiabatic cooler/condenser

A heat rejection device, that is normally air cooled, but incorporates a method of pre-cooling the air with water to increase capacity under high-temperature summer conditions.

aerosol

A suspension in a gaseous medium of solid particles, liquid particles or solid and liquid particles having negligible falling velocity. In the context of this document, a suspension of particles (droplet nuclei) derived from fine droplets from which the water has evaporated leaving small airborne particles, typically $<5 \mu\text{m}$, which can be inhaled deep into the lungs.

air break

An air gap in a drainage system to prevent back-siphonage.

air conditioning

A form of air treatment whereby temperature, humidity, ventilation and air cleanliness are controlled within limits determined by the requirements of the air-conditioned enclosure.

air cooler coil

A heat exchanger for cooling the air that is passed through it.

air heater coil

A heat exchanger for heating the air that is passed through it.

air washer

A device for intimately mixing water and air, the air leaving the device at a condition approaching saturation.

air washer, capillary cell

An air washer having a series of pads sprayed with water through which the air passes.

air washer spray

An air washer with one or more banks of nozzles spraying atomised water into or with the airstream.

algae

Small, usually aquatic plants that require light for growth.

alkali

A chemical that increases the pH of water and reacts with an acid.

alkalinity

The concentration of alkali in water (measured by titration with standard acid solution: not proportional to pH).

antibodies

Substances in the blood that destroy or neutralise toxins or components of bacteria, known generally as antigens; formed as a result of the introduction into the body of the antigen to which they are antagonistic.

anti-vortex plate

A plate positioned horizontally just over an outlet pipe with the aim of preventing air being drawn down into the pipe.

bacterium (plural bacteria)

A microscopic, unicellular organism, without a nuclear membrane.

biocide

A substance that kills micro-organisms.

biofilm

A community of micro-organisms of different types growing together on a surface so that they form a slime layer which may be of a thickness ranging from less than 0.1 mm to several millimetres.

bleach (household)

A solution containing sodium hypochlorite at approximately 5% available chlorine.

bleach (laundry)

A solution containing sodium hypochlorite at approximately 10% available chlorine.

bleed

A deliberate intermittent or continuous discharge of system water to drain to allow the admission of make-up water to the system, thereby controlling the concentration of impurities in the water.

blind end

A length of pipework in which there is no circulation of water, that has been capped off (no terminal outlet).

blowdown

Another term for bleed.

brine

An aqueous solution of a salt.

bromine

An element very similar to chlorine used as a biocide and sometimes as a disinfectant. The main difference between bromine and chlorine is that bromine remains effective at higher pH levels.

calorifier

Apparatus used for the transfer of heat to water in a vessel by either direct or indirect means.

case fatality rate

The proportion of infected persons who die from a disease (normally expressed as a percentage).

cavitation

The formation of bubble-like gaps in a liquid which can be caused by a sudden negative change in pressure or mechanical forces, such as propeller or pump blades.

chemical feeder

Vessel supplying chemicals.

chlorinate

To add chlorine to water, usually in the form of a hypochlorite.

chlorine

An element used as a biocide and for disinfection; see also *combined chlorine*, *free chlorine* and *total chlorine*.

cistern

A fixed water container (usually cold water) commonly called a tank.

combined chlorine

The amount of chlorine that has reacted with nitrogenous or organic materials to form chlorine compounds. If the materials are nitrogenous then the compounds formed are chloramines.

conductivity

The measurement of the capacity of the ions in the water to carry electrical current. Conductivity is used to estimate the total dissolved solids (TDS) in the water. The results are expressed as microsiemens/cm ($\mu\text{S} \cdot \text{cm}^{-1}$) and are temperature dependent. TDS can be calculated by multiplying the conductivity result with a conversion factor of 0.7. Care should be taken not to confuse conductivity and TDS figures (see *TDS*).

conductivity controller

A device that measures the electrical conductivity of water and controls it to a preset value.

cooling tower

Apparatus to cool water in which warm water is exposed to an airstream; in doing so, a portion of the water is evaporated, thus cooling the remaining water. The cooled water is pumped to a condenser or heat exchanger, where it is reheated and then recirculated back through the tower.

cooling water system

A heat exchange system comprising one or more cooling towers and interconnecting recirculating water pipework (with associated pumps, valves and controls).

corrosion coupons

Small strips of different metals, placed in racks into water circuits that can easily be removed, weighed and/or inspected, to enable the corrosion characteristics of the water to be assessed.

corrosion inhibitors

Chemicals designed to prevent or slow down the waterside corrosion of metals.

culture

The technique of detecting bacteria by growing on/in artificial media.

deadleg

A length of water system pipework, leading to a fitting, through which water only passes when there is draw off from the fitting but not frequently enough to avoid the risk of stagnation.

dip slide

Coated plastic slide on which micro-organisms can be grown, examined and quantified. They provide only a broad indication of microbial growth and cannot be used for detecting *Legionella*.

disinfection

The control of micro-organisms by either chemical or non-chemical means (biocides, heat or radiation, for example).

dispersant

A chemical that loosens organic material adhering to surfaces.

DPD (an abbreviation of diethyl-p-phenylene diamine)

A chemical used for measuring chlorine, bromine, ozone or chlorine dioxide in water. DPD produces a pink colour in proportion to the concentration of chlorine, bromine, ozone or chlorine dioxide, but the colour is bleached by excessive concentrations (about 10 mg/l or ppm).

drift

Water droplets and aerosols entrained in the air that discharge from a cooling tower or evaporative condenser. (Note: the visible plume above cooling towers under cool conditions is condensing water vapour (evaporated in the

cooling process) rather than system water droplets/aerosol carried over.)

drift eliminator

Equipment containing a complex system of baffles designed to minimise water droplets and aerosols discharging from a cooling tower or evaporative condenser.

Duty Holder

The person (normally the employer or person in control of the premises) required by law to arrange for a suitable and sufficient risk assessment to be carried out to assess the risk of exposure to *Legionella* bacteria and to appoint a Responsible Person to take managerial control of the risk (see *Responsible Person*).

electrical conductivity meter

An instrument that measures the electrical conductivity of the water flowing through it. This is usually used as a guide to the total dissolved solids present.

evaporative condenser

Apparatus used to condense refrigerant directly by an evaporative cooling process similar to a cooling tower. The refrigerant is piped to a heat exchanger over which water is distributed and a portion of this water is evaporated into the airstream.

evaporative cooling

The process of evaporating part of a liquid by which the necessary latent heat of evaporation is removed from the main bulk of the liquid, thus cooling it.

float-operated valve

A valve used to maintain a liquid level in a tank/cistern by means of a float on the surface of the liquid, set to a predetermined level.

free chlorine

The amount of chlorine available to act as a disinfectant in water. Note that disinfection properties are strongly affected by the pH of the water and decline rapidly in alkaline conditions.

halogen

A grouping of chemical elements containing bromine and chlorine.

HOBr

See *hypobromous acid*.

HOCl

See *hypochlorous acid*.

hypobromite ion (OBr⁻)

A form of bromine predominant at higher pH levels; less effective as a biocide than HOBr.

hypochlorite ion (OCl⁻)

A form of chlorine predominant at higher pH levels; less effective as a biocide than HOCl.

hypobromous acid (HOBr)

The form of bromine that is most effective as a biocide.

hypochlorous acid (HOCl)

The form of chlorine that is most effective as a biocide.

immunosuppressant drugs

Drugs that temporarily suppress the body's natural defences to disease.

incubation temperature

The correct temperature at which dipslides or inoculated culture media should be incubated. Will be dependent on the type of sample being tested.

Langelier index

Langelier calcium carbonate saturation index; this is a predictor for the scale-forming or corrosive properties of water.

Legionnaires' disease

A form of pneumonia caused by bacteria of the genus *Legionella*.

Legionella (plural legionellae)

A bacterium (or bacteria) of the genus *Legionella*.

Legionella pneumophila

A species of bacterium that is the most common cause of Legionnaires' disease and Pontiac fever.

liquid swimming pool chlorine

A solution containing sodium hypochlorite at approximately 10% available chlorine.

Lochgoilhead fever

Similar to Pontiac fever.

make-up water

Fresh water added to recirculating water systems to compensate for losses by evaporation, bleed, drift, windage and leakage.

monoclonal antibody

An antibody produced by a single clone of cells. A monoclonal antibody is therefore a single pure type of antibody. They can be particularly useful for identifying single components on a bacterial cell and are therefore used in typing strains of bacteria.

multiplication temperature

The temperature at which a bacterium grows and divides to create more bacteria (also known as incubation temperature).

operative

The person who operates plant.

passivation

Inducing the formation of an artificial protective layer on a metal surface.

pasteurisation

The heat treatment of a system to destroy micro-organisms.

PCR (polymerase chain reaction)

A technique for rapidly producing many copies of a fragment of DNA (the target) for diagnostic or research purposes (see *qPCR*).

pH

The logarithm of the reciprocal of the hydrogen ion concentration in water, expressed as a number between 0 and 14 to indicate how acidic or alkaline the water is. Values below 7 are increasingly acidic, 7 is neutral and values higher than 7 are progressively alkaline. However, acidity and alkalinity are not proportional to pH (see acidity and alkalinity).

Pontiac fever

Influenza-like illness without pneumonia caused by *L. pneumophila* and some other *Legionella* species.

ppm

Parts per million: numerically equivalent to milligrammes per litre (mg/l); it is, for example, the measure of a dissolved substance noted as the number of parts present in a million parts of the fluid.

purge

Another term for bleed.

qPCR

A quantitative PCR assay, in this document used to determine the concentration of legionellae in a sample of water (see *PCR*).

Responsible Person

The person appointed formally under the terms of the HSE Approved Code of Practice L8 for the prevention or control of legionellosis, to take managerial responsibility and to provide supervision for the implementation of precautions.

relative light units (RLU)

The output measurement of bioluminescence from a luminometer used to determine ATP. Like dip slides it can be used to assess the general microbiological quality of water in a system (see *ATP*).

scale inhibitor

Chemical added to water to inhibit the formation of scale.

sentinel taps

Taps at predetermined points on a cold or hot water distribution system used to characterise the system for temperature measurement or sampling (usually the taps nearest the cistern or calorifier and those most remote).

serogroup

A subgroup of a species.

serological test

A test to identify the subgroup in the laboratory, usually by antibody–antigen reactions.

shock dose

An instantaneous high dose of a chemical or heat treatment to disinfect a system in emergencies.

slug dose

A single dose of a chemical; sometimes called a shock or shot dose. Can also be a term used to describe routine high-concentration periodic dosing (such as with non-oxidising biocides or dispersants) to distinguish it from continuously maintaining a low concentration of chemical.

species

A group of closely allied micro-organisms belonging to the same genus.

strainer

A coarse filter usually positioned upstream of a sensitive component, such as a control valve, pump or heat exchanger, to protect it from debris.

susceptible population

People who are more likely to contract a disease than members of the general population.

total chlorine

The sum of free chlorine and combined chlorine.

total dissolved solids (TDS)

The quantity of solids dissolved in the water, measured in mg/l. These will typically include calcium and magnesium (sodium in softened water), bicarbonate, chloride sulphate and traces of other materials. TDS can be measured directly or determined indirectly from the conductivity reading (see conductivity).

turbidity

The opacity of a liquid, e.g. cloudiness caused by a suspension of particles.

windage

Water lost when wind forces an unusual flow pattern through the base of a cooling tower and blows droplets out of the air intake.

Appendix A2: Emergency cleaning procedure for cooling towers and hot and cold water service systems

A2.1 Contamination or infection

Emergency cleaning and disinfection may be required on rare occasions, such as when a system has become heavily contaminated or when there is a suspected case or outbreak of Legionnaires' disease. In this second instance, it is important to communicate and co-operate with all the health authorities who are investigating the matter to prevent further infection. Unless advised to the contrary, any system suspected of being the source of a *Legionella* infection should be sampled prior to disinfection and the sample passed to the local EHO or HSE inspector for analysis.

A2.2 Sampling

Samples should be taken by competent persons whenever possible in accordance with BS 7592:2008. If this is not possible, sampling may be carried out by others using clean (ideally sterile) bottles, which should be filled in a manner that creates the minimum of splashing, closed tightly and stored in a cool place until they are passed on for analysis.

A2.3 Protection of personnel

Cleaning may be required as a result of contamination that is normally not harmful to health in itself, but which may adversely affect the water hygiene (for example, a swarm of insects, or an oil leak into a cooling tower system). In these cases consideration should still be given to the risk of exposure to *Legionella* during the cleaning process. Disinfection should be carried out before starting the cleaning, and the creation and dissemination of aerosols during cleaning should be minimised.

Cleaning may also be required where the contamination is harmful to health, or when the system is suspected of being associated with *Legionella* infection. In these cases it must be assumed that there is a risk of exposure to *Legionella*, and disinfection must be carried out before starting the cleaning. Even after disinfection there could be *Legionella* within deposits in the system, so the cleaning techniques used must minimise the creation and dissemination of aerosols. If low pressure washing or similar techniques are to be used, precautions must be taken to protect not only those carrying out the work but also others who could be exposed to the aerosol generated.

A health and safety risk assessment is required for cleaning works. The hazards to be considered include:

- substances hazardous to health in any of the cleaning and disinfecting agents used
- substances hazardous to health including the presence of *Legionella* within any contamination in the system, such as scale, fouling or slimes
- manual handling
- working at height
- working with power tools
- working in confined spaces
- working with personal protective equipment.

A2.4 Protection of the environment

Consideration needs to be given to the nature and quantity of any discharge of water containing contaminants, cleaning agents or disinfectants. In the examples above, a swarm of insects would not constitute a pollution threat in any normal discharge, but an oil leak would be a serious one. Most cleaning agents are detergent-based and do not constitute a threat; however, solvents such as degreasing agents, would. Disinfectants, such as chlorine, bromine and chlorine dioxide, could constitute a threat in moderate to large amounts, so they should be neutralised with sodium thiosulphate or sodium bisulphite before disposal.

In all cases, the authority responsible for receiving the discharge must be consulted.

A2.5 Emergency cleaning and disinfection

A2.5.1 Cooling towers and evaporative condensers

Emergency cleaning and disinfection should follow the same process as routine cleaning and disinfection described in Section 4.3.7. It should be borne in mind that longer contact times are preferable to high concentrations for a short period to ensure penetration of deposits and biofilm. It is not necessary, nor recommended, to overdose chlorine; good control of chlorine levels needs to be maintained throughout the disinfection period.

A2.5.2 Hot and cold water services systems

Hot water services and, exceptionally, cold water services should be disinfected and cleaned in the following situations:

- if routine inspection shows there is a high level of contamination. This may be the case when the system or part of it has been substantially altered or entered for maintenance purposes in a manner that may lead to contamination.
- during or following an outbreak or suspected outbreak of Legionnaires' disease.

Emergency disinfection should follow the process for disinfecting a new installation described in BS 8558:2011, but hot water systems can also be thermally disinfected. In addition, cleaning might be required and care should be taken to avoid putting operators at risk, for example by disinfecting before cleaning commences, and again afterwards.

Thermal disinfection can be carried out by increasing the water temperature to at least 60 °C, and maintaining this for 1 hour throughout the storage and all parts of the circulating system, then drawing it through every outlet at a minimum of 60 °C for a minimum of 5 minutes. When carrying out thermal disinfection, the risk of scalding should be considered, and particular care should be taken to ensure that water services are not used, other than by authorised personnel, until water temperatures have dropped to their normal operating level.

Appendix A3: Guidance for suspected outbreaks of Legionnaires' disease

A3.1 Background

If cases of the disease are suspected, medical practitioners must notify the proper officer in the relevant local authority. This is normally the consultant in communicable disease control or consultant in health protection. In the UK (except Scotland) Legionnaires' disease is notifiable under the Health Protection (Notification) Regulations 2010 and in Scotland under the Public Health (Notification of Infectious Diseases) (Scotland) Regulations 1988 (as amended). Under the Regulations, human diagnostic laboratories must also notify the Health Protection Agency of microbiologically confirmed cases of Legionnaires' disease.

Depending on the size and severity of the outbreak, a control of infection team will be set up to identify the source and take action to minimise the risk to public health. This multi-agency team requires clear and strong leadership. The local consultant in communicable disease control will normally work in association with local environmental health officers, the local health authority, the Health Protection Agency, consultant microbiologists and other local authorities if cases are spread over a large area.

In industrial premises the local HSE inspectorate will usually be involved in conjunction with the local authority. Determining the source is a specialist task involving identifying possible sources, epidemiological studies, taking and analysing water samples from systems and interviewing owners and operators.

The engineer's role is an important one in guiding these specialists to the various water systems within the building or premises and, in particular, to the points from which samples can be taken. Easy access to these sampling points is essential, and the correct means of opening and closing valves must be readily available. The engineer must not allow the systems to be drained or disinfected before these samples have been taken, and responsible person for the systems will need to follow the HSE inspector's instructions or those of the local authority environmental health officers.

A3.2 Services

A3.2.1 Hot and cold water services

The investigators will require a plan of the hot and cold water services systems throughout the building from the mains supply inlet to the final end uses. The location of any water storage vessels and calorifiers should be clearly marked and suitable sampling points identified. The end uses should be identified in terms of taps or showers and the nearest and furthest outlets indicated.

A3.2.2 Recreational facilities

The location of any therapy pool, recreational whirlpool or spa pool should be shown. Manufacturers' details of

access to components such as filtration plant should be available. Records of maintenance, cleaning and disinfection are essential.

A3.2.3 Air conditioning

Plans of the building will be needed to show the location and type of cooling towers or other evaporative cooling devices, fresh air inlets to the building and nearest opening windows. The cooling tower water recirculation diagram with water sampling locations should be available. Easy access to inspect the pond water and the condition of the drift eliminators is important. Records of the tower use, maintenance and routine cleaning and disinfection need to be available to the investigation team. Likewise, full details of the water treatment programme need to be available, especially dip slide results and *Legionella* testing.

The location and type of any humidification system must be identified. The location of air cooler coils will need to be identified and ready access provided to the condensate drains.

A3.2.4 Decorative fountains

The location of any decorative or functional water sprays should be identified.

A3.2.5 Excavation work

Any local sites where recent excavation and earth moving has occurred should be noted.

A3.2.6 Medical equipment

Water supplies to any medical equipment should be identified. This includes haemodialysis units, respiratory therapy and dental care.

A3.2.7 Other wet systems

Any special equipment using water that could create aerosols should be identified.

A3.3 Disinfection

If written disinfection procedures for the installations at risk are not already available, consideration should be given to how the different water systems could be disinfected if this becomes necessary. This would be by chlorination or some other means. Disinfection procedures should not start until the members of the investigation team have had the opportunity to survey and sample all the water systems and given their agreement for disinfection to proceed.

Appendix A4: System checklists

A4.1 General

<i>Check:</i>	<i>Answer:</i>	<i>Action:</i>
1. Has a risk assessment been carried out and recorded?	Yes	Ensure that it is kept up to date
	No	Carry out and record risk assessment
2. Have all remedial action items from the risk assessment been addressed?	Yes	Ensure actions have been recorded
	No	Establish appropriate timetable for outstanding actions
3. Is risk assessment regularly reviewed?	Yes	Ensure that reviews are recorded
	No	Carry out review at least every 2 years and record findings
4. Is there a health and safety file for the installation?	Yes	Ensure that it is kept up to date and reviewed regularly
	No	Provide one
5. Is there an up-to-date scheme of control (i.e. written procedures etc.)?	Yes	Ensure procedures are fully appropriate and are being followed and recorded in log book
	No	Provide written scheme of control Ensure actions have been recorded in log book Establish appropriate timetable for outstanding actions
6. Are appropriate records kept?	Yes	Ensure records are comprehensive and accurate
	No	Provide a record book

A4.2 Air conditioning equipment

<i>Check:</i>	<i>Answer:</i>	<i>Action:</i>
1. Has water been found in the ductwork?	Yes	Investigate cause and correct
	No	No action
2. Do the drain trays empty completely during normal operation?	Yes	No action
	No	Check drain tray fall and depth of trap provided and adjust as necessary
3. Do the drain traps dry out in winter?	Yes	Provide a liquid seal for sensitive buildings such as hospitals
	No	No action
4. Are there sufficient inspection hatches to check on state of heat exchangers?	Yes	Ensure they are sealed adequately
	No	Provide them
5. Is there a recirculating water type humidifier?	Yes	Ensure it is kept scrupulously clean and drained down when not in use (e.g. weekends)
	No	No action

A4.3 Cooling towers and evaporative condensers

Check:	Answer:	Action:
1. Is the system water volume marked on the tower?	Yes	Check that it includes pipework and entire system, i.e. pond, condenser, pumps, etc.
	No	Obtain correct information and mark it on the tower
2. Is there an operator's manual?	Yes	Ensure it is readable, readily available and adequately describes the existing equipment
	No	Prepare one
3. Does the operator's manual define normal operating conditions?	Yes	No action
	No	Provide the data
4. Are operational records kept?	Yes	Ensure they are comprehensive and accurate
	No	Provide them
5. Is there a maintenance manual?	Yes	Ensure it is readily available
	No	Consult the tower manufacturer and the cooling circuit designer to have one prepared
6. Are both a maintenance schedule and records kept?	Yes	Ensure that actions are clearly recorded and dated
	No	Provide them
7. Is a water meter fitted to the mains supply to the tower?	Yes	Ensure it can be read easily and that consumption is recorded regularly
	No	Fit one
8. Is all chemical use, including biocide use, recorded?	Yes	Check that quantities used agree with specified dosage rate
	No	Record all chemical consumptions
9. Is total microbiological count checked and recorded?	Yes	Ensure that it is steady and below 10^4 cfu/ml
	No	Provide regular monitoring
10. Is <i>Legionella</i> microbiological level tested quarterly and recorded?	Yes	Ensure that it is non-detectable or 10^2 cfu/l or less
	No	Provide regular quarterly monitoring
11. Can sunlight reach the wet areas?	Yes	Consider shading the tower
	No	No action
12. Are efficient drift eliminators properly installed/fitted?	Yes	No action
	No	Fit properly
13. Is the tower outlet within 10 m of an air inlet or window?	Yes	Consider moving them apart or converting to a dry tower at the end of the useful life of the present one
	No	No action

A4.4 Hot water supply

<i>Check:</i>	<i>Answer:</i>	<i>Action:</i>
1. Is the storage temperature in the calorifier 60 °C at all times?	Yes	No action
	No	Correct to 60 °C
2. Does the hot water reach 50 °C at all taps after running off from 30 seconds to 1 minute?	Yes	No action
	No	Consider trace heating, improving pipe insulation or modifying the installation
3. Does the system contain materials not listed by the Water Research Centre, e.g. natural rubber gaskets or seals?	Yes	Remove as soon as practicable and replace with approved materials
	No	No action
4. Are there long deadlegs?	Yes	Consider modifying the installation to include a high-use fitting at the end of the line, or shortening the deadleg by rearranging secondary pipework
	No	No action
5. Do these long deadlegs serve outlets?	Yes	Ensure the outlets are flushed at least once per week
	No	Remove the redundant piping
6. Are there safety showers or emergency chemical or eye washes on site?	Yes	Check thermostat setting. Flush through every 6 months and test annually or according to manufacturer's recommendations
	No	No action
7. Does the water supply serve susceptible people, e.g. health-care building users?	Yes	Examine where aerosols are likely because of high-pressure operation or close proximity of basin to tap. If likely, take action to minimise aerosol production
	No	No action

A4.5 Cold water service storage cisterns

<i>Check:</i>	<i>Answer:</i>	<i>Action:</i>
1. Do they comply with Water Supply (Water Fittings) Regulations 1999?	Yes	No action
	No	Modify to ensure compliance
2. What is the temperature of the stored water?	<20 °C	No action
	>20 °C	Take action to lower temperature
3. Does the cistern hold more than 24 hours' use?	Yes	Reduce to 24 hours' maximum
	No	No action
4. Is the cistern or inspection hatch covered?	Yes	No action
	No	Fit cover to protect cistern from dirt
5. Is the inside of the cistern clean?	Yes	No action
	No	Clear loose debris and, where internal surface is marked, paint with approved paint
6. Is it a single cistern?	Yes	If the building is in continuous use, such as a hotel or hospital, consider the addition of a small break-tank to facilitate cleaning
	No	Caution: ensure that flow through multiple cisterns is equal and simultaneous, for example by connecting them in series
7. Do the overflow, warning and vent pipes have insect guards?	Yes	No action
	No	Fit them

Appendix A5: International legislation, standards and sources of guidance

Global

World Health Organization (2000) *Guidelines for Safe Recreational-Water Environments. Vol. 2: Swimming pools, spas and similar recreational-water environments* (Geneva: WHO)

World Health Organization (2007) *Legionella and the Prevention of Legionellosis* (Geneva: WHO)

Europe

Eurovent 9/7 (2011) *Recommended Code of Practice to Keep Your Cooling System Efficient and Safe* (Brussels: Eurovent)

Joseph C, Lee J V, Surman-Lee S B, Drasar V, Crespi S and Briand E (2011) *European Working Group for Legionella Infections (EWGLI) Technical Guidelines for the Investigation, Control and Prevention of Travel Associated Legionnaires' Disease*. Available at <http://www.ecdc.europa.eu/en/activities/surveillance/ELDSNet/Documents/EWGLI-Technical-Guidelines.pdf> [accessed 25 Oct. 2012]

Austria

Austrian Agency for Health and Food Safety and Ministry of Health (2005) *Kontrolle und Prävention der reiseassoziierten Legionärskrankheit* (Vienna: AGES)

— (2009) *Prävention der Legionellose, Checkliste zur Einschätzung des Risikos einer Exposition gegenüber Legionellen bei Kontakt mit zentralen Trinkwasser-Erwärmungsanlagen und anderen wasserführenden Systemen* (Vienna: AGES)

Austrian Standards Institute (2007) *ÖNORM B 5019: Hygienerelevante Planung, Betrieb, Wartung, Überwachung und Sanierung von zentralen Trinkwasser-Erwärmungsanlagen* (Vienna: Austrian Standards Agency)

Australia and New Zealand

Australian Institute of Refrigeration, Air-Conditioning and Heating (AIRAH) (2010) *The HVAC Hygiene Best Practice Guideline* (Melbourne: AIRAH)

Department of Human Services Victoria (2007) *Controlling Legionella in warm water systems: A guide for Victorian hospitals and aged care facilities* (Melbourne: Department of Human Services)

Standards Australia (2002) AS/NZS 3666.1:2002: *Air-handling and water systems of buildings – Microbial control. Part 1: Design, installation and commissioning* (Sydney: Standards Australia)

— (2002) AS/NZS 3666.2:2002: *Air-handling and water systems of buildings – Microbial control. Part 2: Operation and maintenance* (Sydney: Standards Australia)

— (2002) AS/NZS 3666.3:2000: *Air-handling and water systems of buildings – Microbial control. Part 3: performance-based maintenance of cooling water systems* (Sydney: Standards Australia)

— (2002) AS 5059:2008: *Power station cooling tower water systems – Management of Legionnaires' disease health risk* (Sydney: Standards Australia)

— (2005) AS 1668: *The use of ventilation and air conditioning in buildings* (Sydney: Standards Australia)

Standards Australia/Standards New Zealand (1995) HB32:1995: *Control of microbial growth in air-handling and water systems of buildings* (Sydney: Standards Australia)

NSW Ministry of Health (2004) *Code of Practice for the Control of Legionnaires' Disease* (Sydney: NSW Ministry of Health)

NSW Ministry of Health (2004) PD 2005:197: *Microbial Control* (Sydney: NSW Ministry of Health)

NSW Ministry of Health (2005) PD 2005:344: *Water – Requirements for the provision of cold and heated water* (Sydney: NSW Ministry of Health)

Belgium

Conseil Supérieur d'Hygiène (2000) *Relatif aux dangers de et aux mesures préventives contre une contamination par Legionella en Belgique* (CSH: 4870) (Brussels: CSH)

— (2002) *Recommandations pour la prévention des infections à Legionella dans les établissements de soins* (CSH : 7509) (Brussels: CSH)

Czech Republic

Ministerstvo Zdravoknictvi (2000) *Metodický návod k zajištění programu surveillance legioneloz* (Prague: Czech Republic Ministry of Health)

Denmark

Statens Serum Institut (2000) *En Vejledning: Legionella i varmt brugsvand. Overvågning, udbredelse og forebyggelse af legionærsygdom* (Copenhagen: SSI)

France

Ministère de l'Écologie et du Développement Durable (2004) *Arrêté du 13 décembre 2004 relatif aux installations de refroidissement par dispersion d'eau dans un flux d'air soumises à autorisation au titre de la rubrique no. 2921* (Paris)

Ministère de la Santé et des Solidarités (2002) *Référentiel d'inspection des mesures de prévention des risques liés aux légionelles dans les établissements de santé*, Direction générale de la santé (Paris)

— (2005) *La prévention du risque lié aux légionelles dans les établissements sociaux et médico-sociaux d'hébergement pour personnes âgées*, Direction générale de la santé (Paris)

— (2005) *Le risque lié aux legionelloses: guide d'investigation et d'aide à la gestion*, Direction générale de la santé (Paris)

— (2006) *Modalités d'organisation des services de l'Etat en cas de survenue de cas groupés de legionellose*, Direction générale de la santé (Paris)

Germany

Deutsches Institut für Normung (1997) *Treatment of swimming pool water, general requirements DIN 19643-1:1997* (Berlin: DIN)

Deutscher Verein für das Gas- und Wasserfach (1993) *Drinking water heating systems and conduits: Technical measures to decrease Legionella growth W 551* (Bonn: DVGW)

— (1996) *Drinking water heating systems and conduits; Technical measures to decrease Legionella growth; rehabilitation and operation W 552* (Bonn: DVGW)

Federal Ministry of Health (2000) *Hygienic requirements on room ventilation facilities VDI 6022* (Berlin: Beuth Verlag)

Protection of Infection Act (IfSG)

Act on Prevention and Control of Infectious Diseases in Man

Federal Environment Agency (www.umweltbundesamt.de)

Hungary

National Centre for Epidemiology and National Institute for Environmental Health (2007) *Guideline on Legionnaires' disease and its prevention* (Budapest)

Ireland

Health Protection Surveillance Centre (2009) *National guidelines for the control of legionellosis in Ireland* (Dublin)

Italy

'Linee guida recanti indicazioni ai laboratori con attività di diagnosi microbiologica e controllo ambientale della legionellosi' (2005) *Gazzetta Ufficiale della Repubblica Italiana*, no. 29, 5 February.

'Linee guida recanti indicazioni sulla legionellosi per i gestori di strutture turistico-recettive e termali' (2005) *Gazzetta Ufficiale della Repubblica Italiana*, no. 28, 4 February.

'Linee guida per la prevenzione ed il controllo della legionellosi' (2000) *Gazzetta Ufficiale della Repubblica Italiana, serie generale*, no. 103

Latvia

Ministry of Welfare (1998) *Epidemiological surveillance of legionellosis* (Riga)

Lithuania

Lithuanian Ministry of Health (2004) *Methodical recommendations for legionellosis diagnostics, treatment, epidemiological surveillance and control* (www.ulpkc.lt) (Vilnius)

— (2007) *Recommendations for legionellosis prevention and control in procedures of legionellosis risk places* (www.ulpkc.lt) (Vilnius)

Malta

Ministry of Health, the Elderly and Community Care (1999) *Code of practice for the prevention of Legionnaires' disease in hotels and other establishments* (Valletta)

Netherlands

Policy rule on working conditions: Arboret beleidsregel 4.87a and 4.87b (2007)

Decree on bathing locations: Besluit Hygiene en veiligheid badinrichtingen en zwemgelegenheden: Preventie van *Legionella* in leidingwater (2007) Staatscourant 2007, 244

Nederlands Normalisatie Instituut (2002) NEN1006:2002 *Algemene voorschriften voor leidingwaterinstallaties* (Delft: NEN)

Drinking water decree: Waterleidingbesluit Hoofdstuk IIIC: *Legionella* preventie (2004) Staatsblad 2004, 576

LCHV draaiboek melding van legionellabacterien in water (2009)

Legionellapreventie bij publieksevenementen (2009)

Guidance documents: *LCI protocol Legionellose* (2009)

Guidance document (cooling towers): *Arbo informatieblad AI32* (2007)

VEWIN werkbladen (2008)

Guidance documents: ISSO publication 55.1 and 55.2 (2007)

Norway

Folkhelseinstituttet (2009) *Forebygging av Legionellasmitte – en veiledning – 1 revisjon* (Oslo)

Statens institutt for folkehelse (2001) *Smittevern 5. Smittevernhåndbok for kommune-helsetjenesten 2002–2003 (Communicable Disease Control Handbook)* (Oslo)

Portugal

Circular Normativa no. 05/DEP de 22/04/2004 – *Programa de Vigilância Epidemiológica Integrada da Doença dos Legionários: Notificação Clínica e Laboratorial de Casos* (2004) (Lisbon: Direcção Geral de Saúde)

Circular Normativa no. 06/DT de 22/04/2004 – *Programa de Vigilância Epidemiológica Integrada da Doença dos Legionários: Investigação Epidemiológica* (2004) (Lisbon: Direcção Geral de Saúde)

Doença dos Legionários. Procedimentos de controlo nos empreendimentos turísticos (2001) (Lisbon: Direcção Geral de Saúde e Direcção Geral de Turismo)

Russia

Epidemiological surveillance for Legionella infection, MU3.1.2.2412-08.

Determination of Legionella pneumophila in the environmental samples, MUK 4.2217-07

Spain

AENOR (2005) Norma UNE 100030 IN/2005: *Guía para la prevención y control de la proliferación y diseminación de la Legionella en las instalaciones* (Madrid)

Ministero de Sanidad y Consumo (1999) *Recomendaciones para la prevención y control de la legionelosis*, Dirección General de Salud Pública

— (2003) REAL DECRETO 865/2003, de 4 de julio, por el que se establecen los criterios higiénico-sanitarios para la prevención y control de la legionelosis. (B.O.E. no. 171, 18 July 2003)

Sweden

Water regulations: Ordinance on Drinking water from the National Food Administration, SLV FS 1989:30, H318

Switzerland

Federal Office of Public Health (1999) *Légionelles et légionellose. Particularités biologiques, épidémiologie, aspects cliniques, enquêtes environnementales, prévention et mesures de lutte* (Berne)

— (2009) *Legionellen und Legionellose* (in German), *Legionella et légionellose* (in French), *Legionella e legionellosi* (in Italian) (Berne)

United States

American Society of Heating, Refrigerating and Air Conditioning Engineers (ASHRAE) (2006) *Control of legionellae in the environment: A guide to the US guidelines* (Atlanta, GA)

— (2012) Standard 188P: *Prevention of Legionellosis Associated with Building Water Systems* (Atlanta, GA)

Association of Water Technologies (2003) *LEGIONELLA 2003: An update and statement* (Rockville, MD)

Cooling Technology Institute (2006) *Legionellosis guideline: Best practices for control of Legionella* (Houston, TX)

Index

- aerosols 3–4, 5, 8, 13, 37, 39, 43, 47, 48
see also drift and drift eliminators
- air conditioning 12–13, 23, 43, 48, 49
see also cooling towers
- air flow, around buildings 17
- air inlets 24, 48, 50
- air washers 6, 43
- algae 16, 43
see also organic fouling
- anti-vortex plates 17, 43
- approved code of practice (L8) 5, 6, 9, 27
- bacteria 3, 4, 10–11, 22, 43
- balance pipes 17
- biocides 11, 12, 19–20, 21, 22, 23, 35, 37, 43
see also bromine; chlorine; chlorine dioxide
- bleed 17, 18, 43
- blood transfusion service premises – *see*
 healthcare premises
- blowdown – *see* bleed
- break tanks 28, 29
- bromine 19, 21, 24, 37, 44, 47
- BS 6920-1:2000 26
- BS 7592:2008 11, 23, 47
- BS 8580:2010 4, 6, 8, 39
- BS 8558:2011 47
- BS EN 111:2003 31
- BS EN 806-4:2010 29
- BS EN 1287:1999 31
- BS EN ISO/IEC 17025:2005 11, 22, 35
- Building Regulations
 Part L 12
 Approved Document G 31
- bypass pipes/valves 20, 21
- calorifiers 8, 29–32, 34, 35, 44
- chemicals – *see* disinfection; water treatment
- chilled water systems 5
- chlorination 23–25, 28, 37, 44
see also disinfection
- chlorine 19, 21, 24–25, 26, 28, 29, 37, 44, 45,
 46, 47
- chlorine dioxide 19, 24, 26, 29, 47
- CIBSE Commissioning Codes 9
- CIBSE Guide G: *Public health engineering* 27
- CIBSE Technical Memorandum TM20: *Health,
 safety and welfare in the built environment*
 6
- cisterns – *see* water storage
- cleaning 17, 19, 23–24, 28, 47
see also disinfection
- clinics – *see* healthcare premises
- Code of Conduct for Service Providers (LCA)
 7
- cold water services 4, 5, 10, 26–29, 34, 35,
 47–48, 52
- commissioning 9, 20–21
- composts 3
- condensers 3, 4, 6, 10, 12–14, 23, 25, 43, 45, 47,
 50
- conductivity 18, 22, 44
- Construction (Design and Management)
 Regulations 2007 8
- construction materials 3, 6, 8, 16, 26, 39, 51
- Control of Legionellosis: A recommended code of
 conduct for service providers* 7
- Control of Substances Hazardous to Health
 Regulations 2002 6
- coolants 3
- cooling 2, 12–25, 32, 43, 45
- cooling towers 3, 4, 6, 8, 10, 13–25, 44, 47, 48,
 50
- Corporate Manslaughter and Corporate
 Homicide Act 2007 6
- corrosion 18–19, 20, 22, 24, 44
- COSHH Regulations 6, 25
- cutting fluids 3
- cycles of concentration 18
- deadlegs 3, 17, 31, 36, 44, 51
- dental equipment 48
- design documentation 8
- dip slides 11, 22, 44
- disinfection 23–25, 26, 27, 29, 30, 37–38, 44,
 47, 48
see also cleaning
- documentation 7–10, 12, 17, 20–21, 25, 26, 37,
 48, 49–50
- dosing 18, 19–20, 24, 26, 37
- drainage 4, 16, 17, 25, 37
- drift and drift eliminators 4, 16, 17, 25, 44, 45
- drinking water 26
- Duty Holder 7, 9, 10, 25, 45
- emergency tasks 47, 48
- environmental considerations 5, 47
- equipment register 5
- Escherichia coli* 37
- evaporative condensers 4, 6, 7, 10, 13–15, 25,
 45, 47, 50
- evaporative cooling – *see* cooling
- excavation work 48
- exhaust noise attenuators 16
- exposure 4, 5, 8
see also aerosols
- filtration 17, 19, 20, 38
- fouling 2, 17, 19
see also algae
- fountains 3, 48
- frost protection 16, 25
- hardness control 19, 20, 22
- health and safety 6, 10, 47
- Health and Safety at Work etc. Act 1974 6
- Health and safety in care homes* (HSG220) 7
- health and safety file 9, 49
- healthcare premises 7, 11, 27, 30, 31
- Health Protection (Notification) Regulations
 2010 1
- Health, safety and welfare in the built environment*
 (TM20) 6
- heat treatment processes 30, 34, 46
- heating systems 5, 32
- hospitals – *see* healthcare premises
- hot spring spa water 3
- hot water services 3, 5, 6, 26–27, 29–36, 47, 51
- HTM 04-01: *The control of Legionella, hygiene,
 'safe' hot water, cold water and drinking
 water systems* 7
- humidifiers 3, 6, 13
- industrial effluent 3
- infection 2–3, 4, 26, 47
see also disinfection; emergency tasks;
 health and safety
- ionisation 26
- irradiation 20
- ISO 9001:2008 10
- ISO 11731:1998 11, 22
- ISO/TS 12869:2012 11
- Legionella and the prevention of legionellosis* 7
- Legionella* bacteria 1–4, 10–12, 22, 45
- legionellosis 1, 3, 5, 6–7
see also Legionnaires' disease; Lochgoilhead
 fever; Pontiac fever
- Legionnaires' disease 1–5, 45, 48
- Legionnaires' disease: A brief guide for dutyholders*
 7
- Legionnaires' disease: The control of legionella
 bacteria in water systems* (L8) 6, 9, 27
- Lochgoilhead fever 45
- log books – *see* documentation
- machine tool cutting coolants 3
- maintenance – *see* operation and maintenance
- make-up water 10, 13, 17, 18, 19, 22, 45
- Management of Health and Safety at Work
 Regulations 1999 6, 10
- medical equipment 48
- mental homes – *see* healthcare premises
- microbiological testing and control 10–12,
 19–20, 22–23, 35, 37
- misting devices 3
- monitoring 10, 12, 20, 21–23, 26, 29, 34, 35
- multiplication factors 3
- nebulisers 3
- NF T90-471 11
- NHS Estates Model Engineering Specification
 31
- noise attenuators 16
- Notification of Cooling Towers and
 Evaporative Condensers Regulations
 1992 6, 13
- nursing homes – *see* healthcare premises
- nutrients – *see* organic fouling
- operation and maintenance 6, 9–10, 20–25,
 27–29, 32–34, 37–38
 manuals 7, 8, 9, 10, 21, 25, 50
see also cleaning; disinfection
- operatives 9, 10, 21, 46
see also health and safety
- organic fouling 2
see also algae
- out-patient accommodation – *see* healthcare
 premises
- ozone – *see* biocides
- pH values 19, 24, 25, 37, 46
- pipes and pipework 16–17, 27, 28, 29–30, 31
see also water distribution
- ponds 4, 13, 16, 17, 24, 48
- Pontiac fever 1, 46
- pools 3, 4, 6, 11, 36–38, 48
- post-chlorination 24–25
- potable water 26
- potting composts 3
- pre-chlorination 24
- pre-treatment 18
- Pseudomonas aeruginosa* 38
- Public Health (Notification of Infectious
 Diseases)(Scotland) Regulations 1988 1
- public water supply 26
- pumps 30, 31, 32
- quality management 10
- quantitative polymerase chain reaction (qPCR)
 11–12

- record-keeping – *see* documentation
- register of equipment 5
- Registered Homes Act 1974 7
- regulatory framework 5–7
- Reporting of Injuries, Diseases and Dangerous Occurrences Regulations 1995 1, 6
- residential homes – *see* healthcare premises
- Responsible Person 7, 9, 10, 13, 25, 37, 46
- risk assessment and management 4–5, 6, 7–12, 35, 39, 40, 47, 49

- sampling 10, 11, 12, 21, 22, 23, 35, 37, 38, 47
- scalding temperatures 30–31, 32, 47
- scale control 19
- scheme of control 7, 10, 39, 40
- Scottish Building Standards Domestic Technical Handbook 31
- screens 17
- sentinel taps 46
- shot dosing 20
- showers 3, 4, 5, 8, 26, 31, 32, 34, 36
- shutdown 21, 25
- silver-copper ionisation 26
- slug dosing 20

- spa pools 3, 6, 11, 36–38, 48
- spa water 3
- stagnation 2, 3, 5, 17, 26, 27
- standby pumps 17, 21, 34
- start-ups 9, 18, 23
- steam systems 5
- storage – *see* water storage
- strainers 17, 24, 29, 37, 46
- susceptibility 1, 4, 8, 39, 40, 46

- taps 3, 4, 24, 26
- temperature – *see* water temperature
- The management of spa pools: Controlling the risks of infection* 37
- thermal disinfection – *see* water temperature
- thermostatic mixing valves (TMVs) 30–31
- total dissolved solids 18, 46
- training 6, 7, 9

- ultraviolet irradiation 8, 20

- valves 17, 18, 30–31, 32, 36, 45
- ventilation – *see* air inlets

- water disposal – *see* drainage
- water distribution 4, 13, 14, 16, 29–30, 31
 - see also* cold water services; hot water services; pipes and pipework
- water features – *see* fountains
- water filtration 17, 19
- Water Fittings and Materials Directory* 16, 26, 28
- water jetting 24
- water meters 17
- water quality – *see* water treatment
- water softeners – *see* hardness control
- water storage 5, 10, 26, 27, 29, 30, 31, 52
- water supply 26, 27, 28
- Water Supply (Water Fittings) Regulations 1999 27, 52
- Water Supply (Water Quality) Regulations 1989 26
- water temperature 2, 3, 5, 6, 26 27–35, 36, 47, 51, 52
- water treatment 3, 7, 10, 17, 18–20, 26, 27, 37
- water volume 17, 31, 50
- whirlpool baths and spas – *see* spa pools
- wind flow 17

