

CUSTOMER SATISFACTION.....“Whatever it takes”

STANDARD FEATURES:

- **48 Inch Wide X 41.5 Inch Deep Footprint**
- **Modular In Line design with SMEMA Communications**
 - Steel Belted Timing Belt Conveyor
 - 2 Section Conveyor Design
 - Adjustable Speed from 1-10 fpm
 - Hand Crank Width Adjust 2-18 inches
- **UV Lamps**
 - F300S-18 UV Curing System
 - Lamps widths available from 6-24 inches
 - Side Reflectors for curing edges of the product
 - Adjustable Z axis up to 4 inches.
 - Internal K300 Modular Blower
 - Built in Cooling Features
- **Heavy Duty Construction**
 - Steel Welded Frame
 - Simple Design for Easy Maintenance
 - Heavy Duty Aluminum Extruded Rails
- **Operator Interface**
 - 6” Touch Screen Monitor
 - Light Tower
- **Built in Safety Features**
 - Front and Rear E-stop Switches
 - E-Stop Interlocked Door Switches
 - Lock Out Panel Switch

OPTIONS:

- Automatic Width Adjust
- Digital Speed Display
- Programmable Width settings
- Automatic Entrance/Exit Doors
- Edge Chain Conveyor
- 24 Inch Product Capability



FRONT VIEW



FOOT PRINT

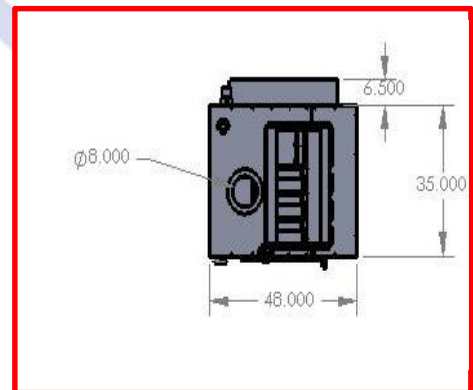

SPECIFICATIONS:

- PCB Size: Min. 2” X 4”
..... Max.18” X 20”
- PCB Height:..... 37.5” + - 2”
- Edge Clearance:..... .100” from edge of PCB
- Air Requirements:.....2 cfm @ 25 PSI
- Power Requirements: 208VAC- 20A/Lamp
- PCB Max Weight: 25 lb.
- PCB Min. Thickness:010”
- Exhaust Requirements: ... 150 scfm per lamp
- Cycle Times:
 - Consult Factory for Cycle time.