

MANN+HUMMEL Filters for Compressors

**Draft
Version**
April 2015



MANN+HUMMEL Filters for compressors



The production processes of today depend on compressed air as a flexible and easy to handle source of energy. Almost all known industrial products are manufactured, packed or transported using compressed air systems which in turn require compressors.

Modern manufacturing and processing methods make high demands on the safety, function, reliability and economy of compressors and compressed air systems. The costs of compressed air are largely determined by the energy costs of the compressor.

As a leading manufacturer of filters for compressors, MANN+HUMMEL meets this challenge with a wide range of modern filtration solutions which are matched to each other and guarantee a high degree of economy. This catalogue provides an overview of

our filters for compressors and matching accessories. MANN+HUMMEL is well-known for its OEM quality and offers filtration solutions for the whole filtration chain of compressors for the OEM market and aftermarket.

Important note for our customers

We are continually developing our product range to further improve our high performance and efficient filtration products. For this reason we expressly reserve the right to make changes to products and range of available products after the printing of this catalogue. This includes technical changes and the discontinuation of products, in particular in the case of older products. Information on changes and general availability is available from your MANN+HUMMEL contact person.

Contents

Product overview	4
Filter configuration	6
Filter selection	6
MANN+HUMMEL air/oil separation	11
MANN+HUMMEL air/oil separators	13
Spin-on separators	19
Air/oil separator box	21
StarBox	23
Accessories for spin-on air/oil separators	25
Filter heads	26
Screw-on connectors	28
Replacement seals	29
MANN+HUMMEL oil filters	31
Standard oil filters	33
Long life oil filters	34
High pressure oil filters	34
Accessories for oil filters	35
Filter heads for oil filters	36
Service indicators / service switches	40
Replacement seals	43
MANN+HUMMEL air cleaners	45
IQORON	47
ENTARON XD	53
EUROPICLON	61
NLG	75
Picolino	87
Picolight	95
System accessories for air cleaners	99
Technical appendix	113
Filter glossary	114
Conversion table	120
Further information	122
Request form for compressor filters	123

Filters for compressors

Product overview

Air/oil separators

Page 13



Application	Screw-type and sliding-vane compressors
Installation site	in pressure reservoir
Residual oil content in mg/m ³	1 to 3 mg/m ³
Operating temperature	up to 100 °C (120 °C)
Pressure drop for a given nominal flow rate	0.17 bar
Available nominal flow rates	0.8 to 76 m ³ /min
Advantages	<ul style="list-style-type: none"> • Process reliability through use of high quality media • Low oil consumption through low residual oil content • Thoroughly tried and tested and reliable • Space saving achieved through compact design

Spin-on separators

Page 19



Application	Screw-type and sliding-vane compressors
Installation site	upright on pressure reservoir
Residual oil content in mg/m ³	1 to 3 mg/m ³
Operating temperature	up to 100 °C (120 °C)
Pressure drop for a given nominal flow rate	0.25 bar
Available nominal flow rates	0.1 to 7.5 m ³ /min
Advantages	<ul style="list-style-type: none"> • Process reliability through use of high quality media • Easy, space-saving fitting and removal • Lower maintenance costs compared to conventional air/oil separators • Lower oil consumption through lower residual oil content
Accessories	Screw-on connectors and heads with connections for oil extraction

Oil filters

Page 31



Application	Oil lubricated and cooled compressors
Operating temperature	up to 120 °C
Pressure drop for a given nominal flow rate	up to 25 bar
Available nominal flow rates	20 to 200 l/min
Advantages	<ul style="list-style-type: none"> • Process reliability through use of high quality media • Easy, space-saving fitting and removal • Thoroughly tried and tested and reliable
Accessories	Heads, service switches, service indicators

Air cleaners

Page 45



Volume flow range	0,15 m ³ /min to 45 m ³ /min
Operating temperature	Continuous: -30 °C to +100 °C For short periods: +100 °C
Selection criteria	<ul style="list-style-type: none"> • High power density • Compact design • Long service life
Typical applications	Compressors
Accessories	Hoses, elbows, service indicators and switches, and rain caps

Configuration of compressor filters

MANN+HUMMEL offers a simple process for the configuration of all the filters in your compressor.

The basis is the free air delivery (FAD) of your compressor. Select the corresponding FAD in the diagram and all filters listed on the right will be suitable for your compressor. The suitable filter for a separator is determined through selection of the pressure [bar_{abs}] in the pressure reservoir. Filters determined in this way can be ordered directly from your MANN+HUMMEL partner using the specified order numbers.

This method of determining the right filter is based on certain conditions. In individual cases the conditions in the compressor may deviate from these conditions. If operation of the compressor in the field is unsatisfactory, please contact your MANN+HUMMEL partner. He will provide further assistance to improve the filter selection.

Filter selection Air/oil separators

Vessel pressure 6 [bar _{abs}]				Vessel pressure 8 [bar _{abs}]				Vessel pressure 10 [bar _{abs}]				Vessel pressure 12 [bar _{abs}]				Order no.
FAD [m ³ /min]		Limiting pressure [bar _{abs}]		FAD8 [m ³ /min]		Limiting pressure [bar _{abs}]		FAD10 [m ³ /min]		Limiting pressure [bar _{abs}]		FAD12 [m ³ /min]		Limiting pressure [bar _{abs}]		
min	max	min	max	min	max	min	max	min	max	min	max	min	max	min	max	
0.6	1.1	4.7	11.9	0.8	1.5	6.5	15.8	1	1.9	8.2	19.8	1.2	2.3	9.9	23.7	49 300 55 231
0.7	1.3	5	12.5	0.9	1.7	6.6	16.1	1.1	2.1	8.1	19.6	1.4	2.5	9.7	25	49 300 53 361
1	1.8	4.8	12.3	1.3	2.4	6.4	16	1.7	3	8	20.9	2	3.6	9.6	24.6	49 300 53 222
1	1.8	4.8	12.3	1.3	2.4	6.4	16	1.7	3	8	20.9	2	3.6	9.6	24.6	49 300 53 281
1	1.8	4.8	12.2	1.3	2.4	6.4	15.9	1.7	3.1	8.3	20.8	2	3.7	9.8	24.5	49 300 53 301
1.5	2.8	4.9	12.1	2	3.7	6.5	16.1	2.5	4.6	8	20.1	3	5.6	9.8	24.1	49 301 55 581
1.6	2.9	4.9	12.5	2.1	3.8	6.4	16.4	2.6	4.8	8.1	20.3	3.1	5.8	9.8	24.2	49 301 55 751
1.7	3.1	4.9	12.4	2.2	4.1	6.5	16	2.8	5.1	8.1	20.4	3.4	6.2	9.8	24.7	49 301 55 611
1.7	3.1	4.9	12.4	2.2	4.1	6.5	16	2.8	5.1	8.1	20.4	3.4	6.2	9.8	24.7	49 301 55 631
2	3.6	4.9	12.5	2.6	4.8	6.5	16.3	3.3	6	8.2	20.6	3.9	7.2	9.8	24.4	49 301 55 151
2	3.6	4.9	12.5	2.6	4.8	6.5	16.3	3.3	6	8.2	20.6	3.9	7.2	9.8	24.4	49 301 55 561
2.1	3.8	4.9	12.5	2.7	5	6.5	16.1	3.4	6.3	8.1	20.2	4.1	7.5	9.7	24.4	49 301 55 651
2.3	4.2	4.9	12.3	3	5.6	6.5	16.1	3.8	7	8.1	20.3	4.6	8.4	9.8	24.6	49 301 54 811
2.4	4.5	4.9	12	3.3	6	6.5	16.6	4.1	7.5	8.2	20.6	4.9	8.9	9.7	24.6	49 301 55 601
2.6	4.8	4.9	12.1	3.5	6.4	6.5	16.3	4.4	8	8.1	20.5	5.3	9.6	9.7	24.7	49 301 55 621
3	5.4	4.8	12.4	4	7.3	6.5	16.5	4.9	9.1	8.2	20.2	5.9	10.9	9.8	24.3	49 301 55 761
3	5.5	4.9	12.3	4	7.3	6.5	16.4	5	9.1	8.1	20.5	6	11	9.8	24.6	49 301 55 571
3.1	5.7	4.9	12.2	4.1	7.6	6.5	16.2	5.2	9.5	8.1	20.5	6.2	11.4	9.8	24.4	49 302 55 481
3.1	5.7	4.9	12.2	4.1	7.6	6.5	16.2	5.2	9.5	8.1	20.5	6.2	11.4	9.8	24.4	49 302 55 841
3.9	7.1	4.9	12.3	5.2	9.5	6.5	16.4	6.5	11.8	8.1	20.6	7.7	14.2	9.8	24.3	49 302 53 851
4	7.3	4.9	12.4	5.3	9.7	6.5	16.4	6.6	12.1	8.1	20.4	7.9	14.5	9.7	24.4	49 302 52 911

Filter selection

Air/oil separators

Vessel pressure 6 [bar _{abs}]				Vessel pressure 8 [bar _{abs}]				Vessel pressure 10 [bar _{abs}]				Vessel pressure 12 [bar _{abs}]				Order no.
FAD [m ³ /min]		Limiting pressure [bar _{abs}]		FAD8 [m ³ /min]		Limiting pressure [bar _{abs}]		FAD10 [m ³ /min]		Limiting pressure [bar _{abs}]		FAD12 [m ³ /min]		Limiting pressure [bar _{abs}]		
min	max	min	max	min	max	min	max	min	max	min	max	min	max	min	max	
4.1	7.4	4.8	12.4	5.4	9.9	6.5	16.3	6.8	12.4	8.1	20.5	8.1	14.9	9.8	24.4	49 302 55 271
4.1	7.4	4.8	12.4	5.4	9.9	6.5	16.3	6.8	12.4	8.1	20.5	8.1	14.9	9.8	24.4	49 302 55 761
4.2	7.7	4.9	12.3	5.6	10.2	6.5	16.4	7	12.8	8.1	20.5	8.4	15.4	9.8	24.6	49 302 55 871
5	9.2	4.9	12.1	6.7	12.3	6.5	16.3	8.4	15.4	8.1	20.4	10.1	18.5	9.8	24.5	49 407 53 101
5.1	9.4	4.9	12.2	6.8	12.6	6.5	16.2	8.6	15.7	8.1	20.5	10.3	18.8	9.7	24.5	49 302 55 831
5.4	9.9	4.9	12.3	7.2	13.2	6.5	16.4	9	16.5	8.1	20.4	10.8	19.8	9.8	24.5	49 302 55 131
5.7	10.5	4.9	12.2	7.6	14	6.5	16.3	9.5	17.4	8.1	20.4	11.4	20.9	9.7	24.4	49 302 55 801
6.1	11.2	4.9	12.2	8.1	14.9	6.5	16.3	10.2	18.6	8.1	20.5	12.2	22.4	9.8	24.5	49 302 55 861
6.9	12.6	4.9	12.3	9.1	16.8	6.5	16.2	11.4	20.9	8.1	20.4	13.7	25.1	9.7	24.5	49 303 55 171
7.2	13.2	4.9	12.3	9.6	17.6	6.5	16.3	12	22	8.1	20.4	14.4	26.4	9.8	24.5	49 303 55 121
7.2	13.2	4.9	12.3	9.6	17.6	6.5	16.3	12	22	8.1	20.4	14.4	26.4	9.8	24.5	49 303 55 521
7.5	13.8	4.9	12.2	10	18.3	6.5	16.3	12.5	22.9	8.1	20.4	15	27.5	9.8	24.5	49 303 55 491
7.5	13.8	4.9	12.2	10	18.3	6.5	16.3	12.5	22.9	8.1	20.4	15	27.5	9.8	24.5	49 303 55 501
7.8	14.2	4.9	12.3	10.4	19	6.5	16.4	12.9	23.7	8.1	20.3	15.5	28.5	9.8	24.4	49 303 55 551
7.9	14.6	4.9	12.2	10.6	19.4	6.5	16.3	13.2	24.3	8.1	20.3	15.9	29.1	9.7	24.5	49 303 55 531
8.3	15.3	4.9	12.2	11.1	20.4	6.5	16.3	13.9	25.5	8.1	20.4	16.7	30.5	9.7	24.5	49 303 53 501
8.7	15.9	4.9	12.3	11.6	21.2	6.5	16.3	14.5	26.5	8.1	20.4	17.4	31.9	9.8	24.5	49 303 55 571
8.7	15.9	4.9	12.2	11.6	21.3	6.5	16.3	14.5	26.6	8.1	20.4	17.4	31.9	9.8	24.5	49 303 55 511
9.2	16.8	4.9	12.3	12.2	22.4	6.5	16.3	15.3	28	8.1	20.5	18.3	33.6	9.8	24.5	49 303 55 451
10	18.4	4.9	12.2	13.4	24.5	6.5	16.4	16.7	30.6	8.1	20.4	20	36.8	9.8	24.4	49 304 55 371
10.1	18.4	4.9	12.3	13.4	24.6	6.5	16.3	16.8	30.7	8.1	20.5	20.1	36.9	9.8	24.5	49 304 52 241
11.6	21.2	4.9	12.3	15.4	28.3	6.5	16.3	19.3	35.4	8.1	20.4	23.2	42.5	9.8	24.5	49 304 55 241
11.6	21.2	4.9	12.3	15.4	28.3	6.5	16.3	19.3	35.4	8.1	20.4	23.2	42.5	9.8	24.5	49 414 53 111
12	22.1	4.9	12.2	16.1	29.4	6.5	16.4	20.1	36.8	8.1	20.4	24.1	44.1	9.7	24.5	49 304 55 381
12.4	22.7	4.9	12.3	16.5	30.3	6.5	16.3	20.6	37.9	8.1	20.4	24.8	45.4	9.8	24.5	49 305 55 421
12.7	23.2	4.9	12.3	16.9	31	6.5	16.3	21.1	38.7	8.1	20.4	25.4	46.5	9.8	24.5	49 305 55 401
12.7	23.2	4.9	12.3	16.9	31	6.5	16.3	21.1	38.7	8.1	20.4	25.4	46.5	9.8	24.5	49 418 53 101
13.7	25.2	4.9	12.2	18.3	33.6	6.5	16.3	22.9	42	8.1	20.4	27.5	50.4	9.8	24.5	49 305 55 121
15.3	28.1	4.9	12.2	20.4	37.5	6.5	16.3	25.6	46.8	8.1	20.4	30.7	56.2	9.8	24.5	49 306 55 311
15.4	28.2	4.9	12.3	20.5	37.5	6.5	16.3	25.6	46.9	8.1	20.4	30.7	56.3	9.8	24.5	49 306 55 301
16.3	29.8	4.9	12.3	21.7	39.7	6.5	16.3	27.1	49.7	8.1	20.4	32.5	59.6	9.8	24.5	49 306 53 161
17.1	31.4	4.9	12.2	22.8	41.8	6.5	16.3	28.5	52.3	8.1	20.4	34.2	62.8	9.8	24.5	49 306 55 321
17.6	32.3	4.9	12.2	23.5	43.1	6.5	16.3	29.4	53.9	8.1	20.4	35.3	64.7	9.8	24.5	49 306 55 131
18	33	4.9	12.3	24	44	6.5	16.3	30	54.9	8.1	20.4	36	65.9	9.8	24.5	49 306 55 281
20.6	37.8	4.9	12.2	27.5	50.4	6.5	16.3	34.4	63	8.1	20.4	41.3	75.7	9.8	24.5	49 307 55 191
21.2	38.9	4.9	12.2	28.3	51.9	6.5	16.3	35.4	64.8	8.1	20.4	42.4	77.8	9.8	24.5	49 307 55 111
24.6	45	4.9	12.3	32.7	60	6.5	16.3	40.9	75	8.1	20.4	49.1	90	9.8	24.5	49 309 54 101
28.2	51.8	4.9	12.2	37.7	69	6.5	16.3	47.1	86.3	8.1	20.4	56.5	103.5	9.8	24.5	49 310 54 121
31.1	57	4.9	12.2	41.5	76	6.5	16.3	51.8	95	8.1	20.4	62.2	114	9.8	24.5	49 311 54 101

Filter selection

Spin-on separators

Vessel pressure 6 [bar _{abs}]				Vessel pressure 8 [bar _{abs}]				Vessel pressure 10 [bar _{abs}]				Vessel pressure 12 [bar _{abs}]				Order no.
FAD [m ³ /min]		Limiting pressure [bar _{abs}]		FAD8 [m ³ /min]		Limiting pressure [bar _{abs}]		FAD10 [m ³ /min]		Limiting pressure [bar _{abs}]		FAD12 [m ³ /min]		Limiting pressure [bar _{abs}]		
min	max	min	max	min	max	min	max	min	max	min	max	min	max	min	max	
0.2	0.8	3.7	20	0.3	1.0	4.5	20	0.3	1.3	6.1	20	0.4	1.5	7.4	20	LB 719/2
0.2	0.8	3.8	20	0.3	1.1	5.0	20	0.3	1.4	6.3	20	0.4	1.7	7.6	20	LB 719/20 StarBox
0.4	1.5	3.1	20	0.5	2.0	4.2	20	0.6	2.5	5.2	20	0.8	3.0	6.3	20	LB 962/2
0.4	1.7	3.1	20	0.6	2.2	4.1	20	0.7	2.8	5.1	20	0.8	3.3	6.1	20	LB 962/20 StarBox
0.5	2.3	4.4	20	0.8	3.0	5.9	20	0.9	3.8	7.4	20	1.1	4.5	8.9	20	LB 1374/2
0.6	2.5	4.4	20	0.8	3.3	5.8	20	1.0	4.1	7.3	20	1.2	5.0	8.8	20	LB 1374/20 StarBox
0.8	3.0	4.1	14	1.0	4.0	5.5	14	1.3	5.0	6.9	14	1.5	6.0	8.3	14	LB 11 102/2
1.0	4.1	3.9	20	1.4	5.5	5.3	20	1.7	6.9	6.6	20	2.1	8.3	7.3	20	LB 13 145/3
1.1	4.5	3.8	20	1.5	6.0	5.1	20	1.9	7.5	6.4	20	2.3	9.0	7.7	20	LB13 145/20 StarBox

Filter selection

Oil filters

Order no.	Nominal flow rate [l/min] [gpm]	Max. pressure [bar _{abs}]	Max. FAD ¹⁾ [m ³]	Max. compressor performance ¹⁾ [kW]
Standard filters Filter fineness acc. to ISO 16889 [µm (c)], 50 % = 14 / 99 % = 38, service life approx. 2,000 hrs				
WD 940/2	50 (13.21)	25	7	41
W 950/31	65 (17.17)	14	9	54
W 962/14	75 (19.82)	14	10	62
WD 962/8	90 (23.78)	25	12	74
W 11 102/16	128 (33.82)	14	18	106
WD 13 145/4	180 (47.56)	20	25	149
Long life filters Filter fineness acc. to ISO 16889 [µm (c)], 50 % = 4 / 99 % = 10, service life approx. 4,000 hrs				
WD 962/21	65 (17.17)	25	9	54
WD 1374/6	100 (26.42)	20	14	83
WD 13 145/14	205 (54.16)	20	28	169
High pressure filters Filter fineness acc. to ISO 16889 [µm (c)], 50 % = 4 / 99 % = 11, service life approx. 4,000 hrs				
WH 945/2	70 (18.49)	35	10	58
WH 980/1	100 (26.42)	35	14	83

¹⁾ The figures for max. FAD and compressor performance are to be understood as guide values. The requirements of the manufacturer of the pressure stage apply or if necessary the suitable oil volume for the whole system has to be observed.

Filtration chain in the compressor

Although a compressor has a closed oil circuit, it is nevertheless generally fitted with three filters. These are required to remove dust, wear particles and oil degradation products from the oil and also to separate the oil used to cool the air in the compression process from the resulting compressed air and to return this oil to the compressor oil circuit.

The first function is managed using an air cleaner and an oil filter and the second by an oil separator (air/oil separator or spin-on separator). Although the tasks of the individual filters are clearly separated, there are, however, certain dependencies which require careful fine tuning.

In this way particles from the ambient air can enter the system via the intake, pass the air cleaner and compression stage and contaminate the oil. Therefore as well as retaining oil degradation products and wear particles, the oil filter located downstream also has to retain particles from the intake air which were not separated.

The same is true for the separator which not only separates oil from the compressed air, but is also burdened with the particles contained in the oil. These particles consist of everything which has passed the oil filter and which has been added to the compressed air in the compression chamber.

Therefore the complete filtration chain has to be taken into account, i.e. the filtration system is only as strong as its weakest component.

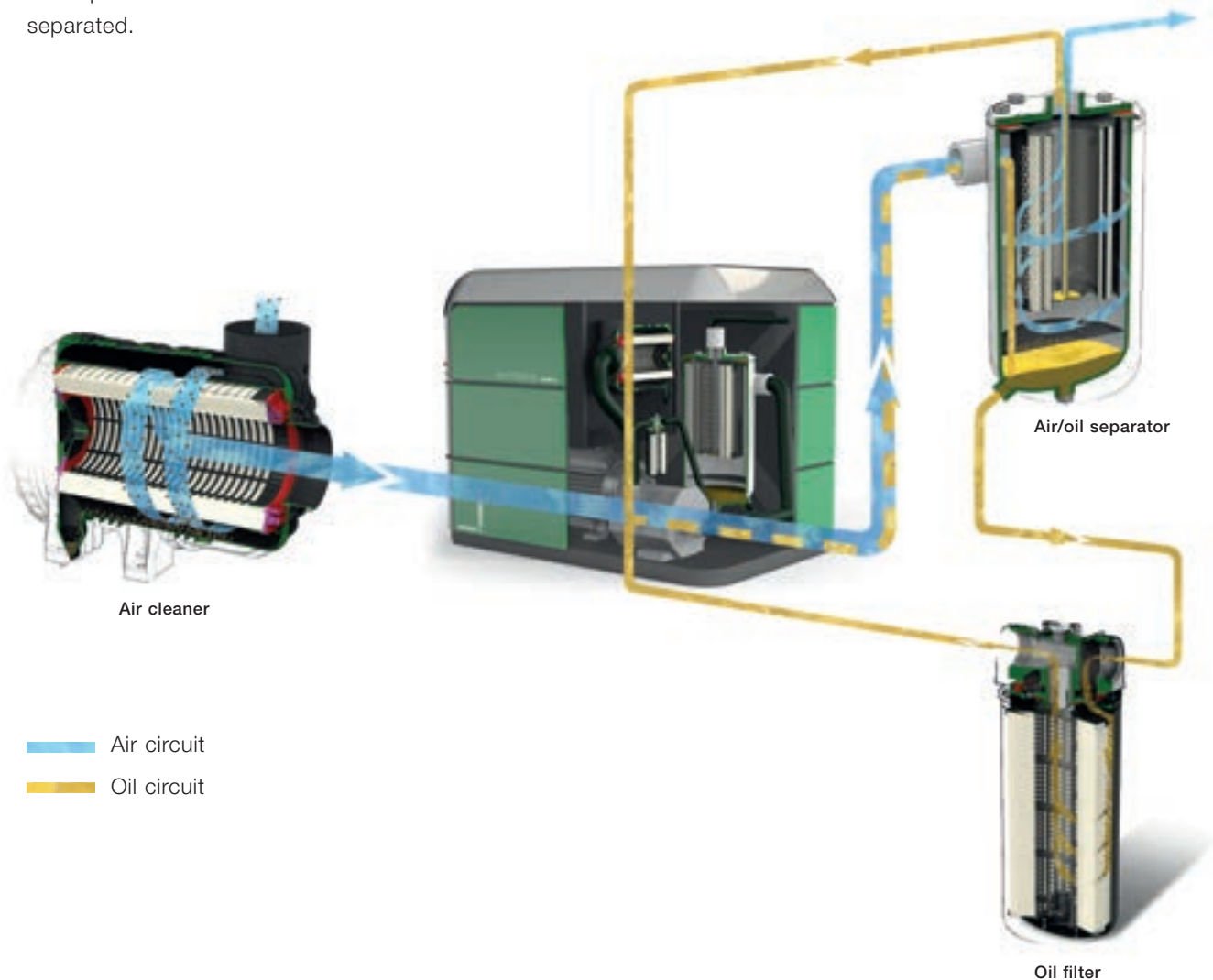



MANN+HUMMEL Air/oil separation for use in compressors

Air/oil separators, Spin-on separators, Accessories



MANN+HUMMEL Air/oil separation

Oil-lubricated screw compressors represent a controllable and smooth-running method for the generation of low-pulsation compressed air for use in industrial applications. The economic operation of these compressors is ensured through use of modern components. MANN+HUMMEL air/oil separators and spin-on separators are characterised by low pressure drop, high separation efficiency, compact design and sustainable operational reliability for the whole of the operating time.



Working principle

Air/oil separators and spin-on separators function according to the coalescence principle. A twin screw arrangement compresses the gas and it is transferred to a pressure reservoir. Oil is injected to seal the pair of screws to the housing and to lead the compressor heat away and is transferred with the compressed gas to the pressure reservoir. After pre-separation oil droplets remain in the compressed gas. Air/oil separators are used to join the droplets into larger droplets which are then collected and returned to the oil circuit. This minimises oil consumption in the compressor and ingress of oil into the compressed air network.

Aggregation of the oil droplets

Air/oil separators and spin-on separators consist of a winding design with a fleece medium arranged concentrically inside the winding. This is described as a post-separator. The winding and post-separator

are held by a perforated tube. As the air to be filtered passes through the wound separation medium fine droplets are retained while the compressed gas can essentially pass through without loss. In the medium the fine oil droplets combine to form larger droplets. The gas is free to escape on the outflow side of the winding while the agglomerated oil either trickles due to gravity down the pressure-resistant tube or is retained by the post-separator. The oil also drains away here under the effect of gravity and collects in a trough designed for the purpose. The positive pressure in the pressure reservoir allows the oil to return to the oil circuit via a scavenge line.

Factors which influence the coalescence

The function of the coalescence separator is influenced by various physical effects and characteristics of the gas to be compressed and the oil used (temperature, viscosity, etc.).

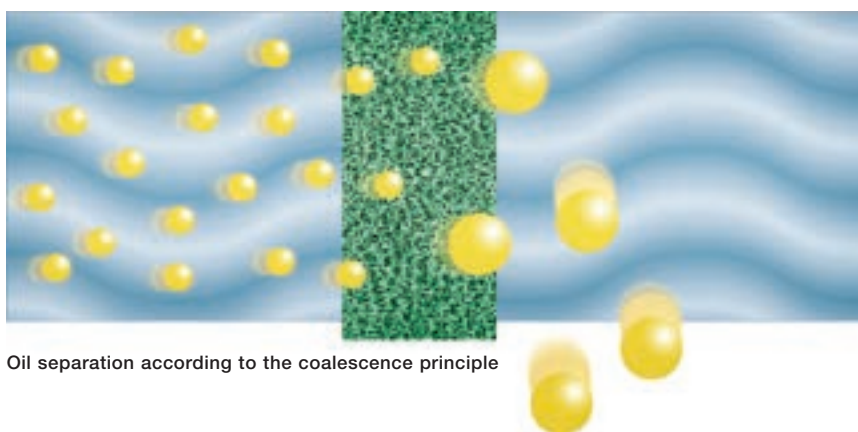

Oil separation according to the coalescence principle

Air/oil separation for compressors

Air/oil separators



MANN+HUMMEL Air/oil separators for compressors

The integration of air/oil separators in the pressure reservoir of the compressor enables the best possible separation performance with low pressure drop over the filter. MANN+HUMMEL air/oil separators have advanced separation technology. It increases the power density and therefore MANN+HUMMEL separators are more compact than conventional separators.

Sealing

All the air/oil separators listed in the catalogue have two flange seals as standard. This enables reliable sealing between the cover, air/oil separator and pressure reservoir.

Grounding

All the metallic parts of a MANN+HUMMEL air/oil separator have the same electric potential. The air/oil separator can be connected to the grounding of the compressor via the flange and its seals to prevent electrostatic charges.

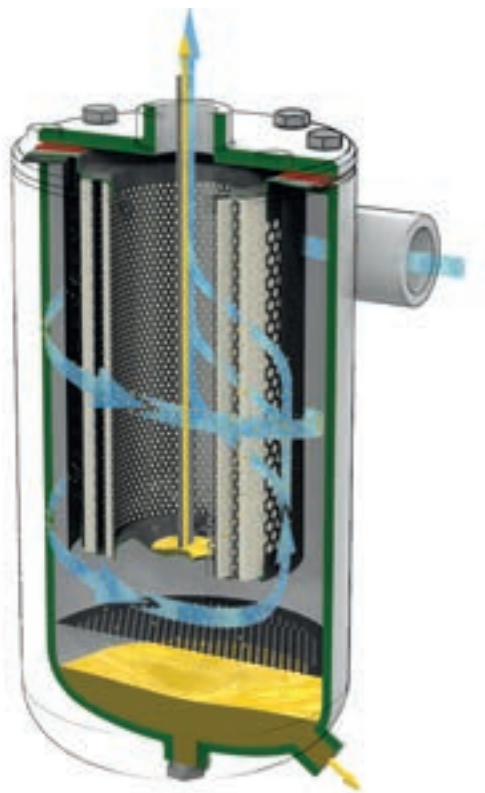

Integration in pressure reservoir

The following points are valid for the compression of the ambient air under standard conditions. If MANN+HUMMEL air/oil separators are used under strongly deviating ambient conditions, please consult your MANN+HUMMEL partner.

- The oil content of the compressed air is lowered through preseparation. The maximum oil content after preseparation should not exceed a value of approx. 5 g/Nm³.
- Sufficient distance to oil level (approx. > 0.5 of the diameter of the separator)
- No direct flow to the separator
- The permitted volume flow rates are listed in the dimensioning table (page 6). Local peak loads (with pressure reduction) or load undercutting (pressure increase) should also not exceed the given ranges.
- The oil scavenge line must be large enough to return the separated volume of oil.

Specifications

- Continuous operating temperature¹⁾: max. 100 °C, for short periods: max. 120 °C
- MANN+HUMMEL tests using standard oils for compressors (ISO VG46)²⁾
- Pressure drop (500 hrs) : < 0.3 bar
- Residual oil content (500 hrs) : < 3 mg/Nm³
- Service life: 500 hrs bis zu bis zu 4.000 hrs (under ideal conditions, depending on the application)

¹⁾ For short periods: the dwell time at the temperature permitted for short periods must not exceed 10 minutes. The time between 2 short-term peaks must be at least 30 minutes. After approx. 300 peaks have been reached we recommend changing the seal and filter.

²⁾ The use of substantially different oils requires validation of the oil.

Air/oil separators for compressors

Dimensions and order numbers

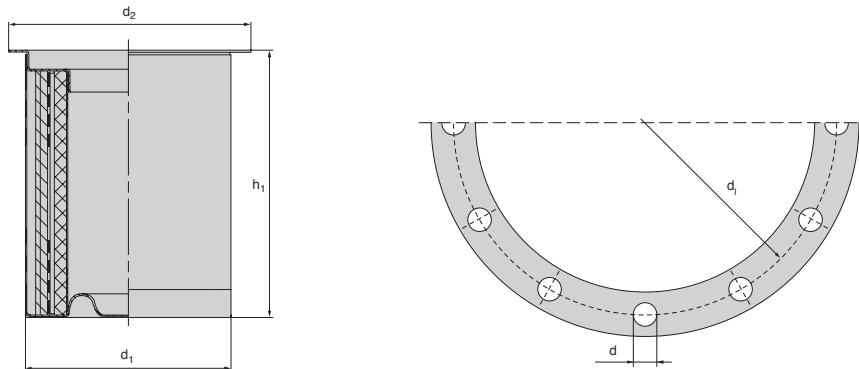

Order no.	Dimensions in mm (<i>Dimensions in inches</i>)						Technical features	
	d ₁	d ₂	h ₁	d _l	d	Number of holes	Fleece preseparator	
49 300 55 231	135 (5.31)	160 (6.30)	65 (2.56)	-	-	-	-	
49 300 53 361	100 (3.94)	128 (5.04)	110 (4.35)	-	-	-	X	
49 300 53 222	100 (3.94)	175 (6.89)	150 (5.91)	150 (5.91)	14 (0.55)	8	-	
49 300 53 281	100 (3.94)	142 (5.59)	150 (5.91)	-	-	-	-	
49 300 53 301	100 (3.94)	128 (5.04)	170 (6.69)	-	-	-	-	
49 301 55 581	135 (5.31)	170 (6.69)	160 (6.30)	-	-	-	-	
49 301 55 751	135 (5.31)	215 (8.46)	165 (6.50)	-	-	-	X	
49 301 55 611	135 (5.31)	220 (8.66)	175 (6.89)	192 (7.56)	13.5 (0.53)	6	-	
49 301 55 631	135 (5.31)	170 (6.69)	175 (6.89)	-	-	-	-	
49 301 55 151	135 (5.31)	215 (8.46)	200 (7.87)	-	-	-	X	
49 301 55 561	135 (5.31)	170 (6.69)	200 (7.87)	-	-	-	-	
49 301 55 651	170 (6.69)	245 (9.65)	165 (6.50)	210 (8.27)	17 (0.67)	8	-	
49 301 54 811	135 (5.31)	165 (6.50)	230 (9.06)	-	-	-	X	
49 301 55 601	170 (6.69)	200 (7.87)	180 (7.09)	-	-	-	-	
49 301 55 621	220 (8.66)	274 (10.79)	274 (10.79)	-	-	-	-	
49 301 55 761	135 (5.31)	182 (7.17)	293 (11.54)	-	-	-	-	
49 301 55 571	170 (6.69)	200 (7.87)	230 (9.06)	-	-	-	-	
49 302 55 841	135 (5.31)	170 (6.69)	305 (12.01)	-	-	-	-	
49 302 53 851	160 (6.30)	200 (7.87)	310 (12.20)	-	-	-	-	
49 302 52 911	220 (8.66)	274 (10.79)	230 (9.06)	-	-	-	X	

Air/oil separators for compressors

Dimensions and order numbers

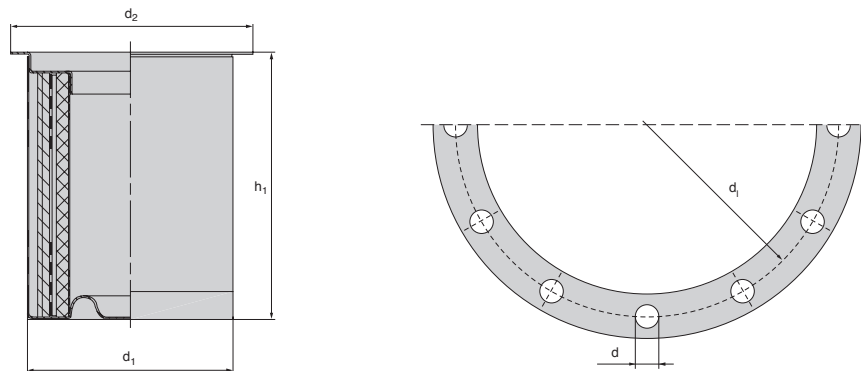

Order no.	Dimensions in mm (<i>Dimensions in inches</i>)						Technical features
	d ₁	d ₂	h ₁	dl	d	Number of holes	Fleece preseparator
49 302 55 271	170 (6.69)	200 (7.87)	305 (12.01)	-	-	-	-
49 302 55 761	170 (6.69)	200 (7.87)	305 (12.01)	-	-	-	X
49 302 55 871	170 (6.69)	245 (9.65)	314 (12.36)	210 (8.27)	17 (0.67)	8	-
49 407 53 101	275 (10.83)	328 (12.91)	230 (9.06)	-	-	-	-
49 302 55 831	170 (6.69)	200 (7.87)	380 (14.96)	-	-	-	-
49 302 55 131	220 (8.66)	290 (11.42)	305 (12.01)	-	-	-	X
49 302 55 801	170 (6.69)	245 (9.65)	420 (16.54)	210 (8.27)	17 (0.67)	8	-
49 302 55 861	170 (6.69)	245 (9.65)	447 (17.60)	210 (8.27)	17 (0.67)	8	-
49 303 55 171	275 (10.83)	328 (12.91)	305 (12.01)	-	-	-	X
49 303 55 121	220 (8.66)	290 (11.42)	400 (15.75)	-	-	-	X
49 303 55 521	220 (8.66)	274 (10.79)	400 (15.75)	-	-	-	-
49 303 55 491	300 (11.81)	355 (13.98)	305 (12.01)	-	-	-	-
49 303 55 501	300 (11.81)	348 (13.70)	305 (12.01)	-	-	-	-
49 303 55 551	300 (11.81)	343 (13.50)	315 (12.40)	-	-	-	-
49 303 55 531	275 (10.83)	328 (12.91)	350 (13.78)	-	-	-	-
49 303 53 501	220 (8.66)	290 (11.42)	460 (18.11)	-	-	-	-
49 303 55 571	300 (11.81)	400 (15.75)	350 (13.78)	350 (13.78)	26 (1.02)	12	-
49 303 55 511	300 (11.81)	355 (13.98)	350 (13.78)	-	-	-	-
49 303 55 451	275 (10.83)	328 (12.91)	400 (15.75)	-	-	-	-
49 304 55 371	300 (11.81)	350 (13.78)	400 (15.75)	-	-	-	-

Air/oil separators for compressors

Dimensions and order numbers

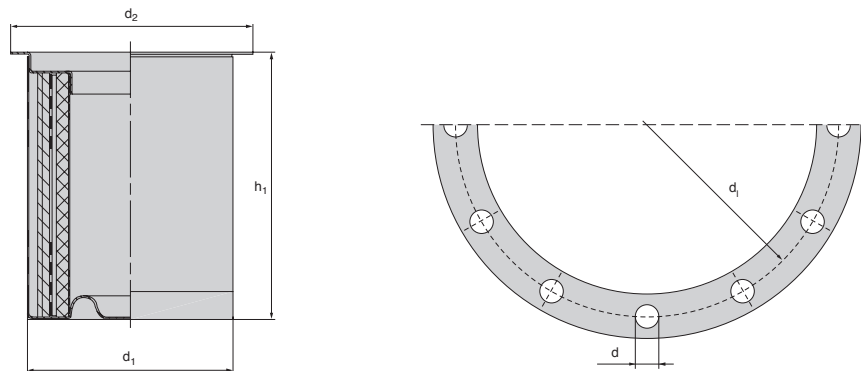

Order no.	Dimensions in mm (<i>Dimensions in inches</i>)						Technical features
	d ₁	d ₂	h ₁	d _l	d	Number of holes	Fleece preseparator
49 304 52 241	350 (13.78)	439 (17.28)	350 (13.78)	-	-	-	-
49 304 55 241	275 (10.83)	360 (14.17)	500 (19.69)	-	-	-	-
49 414 53 111	275 (10.83)	328 (12.91)	500 (19.69)	-	-	-	-
49 304 55 381	393 (15.47)	440 (17.32)	370 (14.57)	-	-	-	-
49 305 55 421	400 (15.75)	434 (17.09)	370 (14.57)	-	-	-	-
49 305 55 401	300 (11.81)	355 (13.98)	500 (19.69)	-	-	-	-
49 418 53 101	300 (11.81)	355 (13.98)	500 (19.69)	-	-	-	-
49 305 55 121	300 (11.81)	355 (13.98)	540 (21.26)	-	-	-	-
49 306 55 311	300 (11.81)	355 (13.98)	600 (23.62)	-	-	-	-
49 306 55 301	300 (11.81)	355 (13.98)	600 (23.62)	-	-	-	-
49 306 53 161	400 (15.75)	434 (17.09)	480 (18.90)	-	-	-	-
49 306 55 321	393 (15.47)	440 (17.32)	515 (20.28)	-	-	-	-
49 306 55 131	400 (15.75)	434 (17.09)	520 (20.47)	-	-	-	-
49 306 55 281	300 (11.81)	355 (13.98)	700 (27.56)	-	-	-	-
49 307 55 191	300 (11.81)	355 (13.98)	800 (31.50)	-	-	-	-
49 307 55 111	400 (15.75)	434 (17.09)	620 (24.41)	-	-	-	-
49 309 54 101	475 (18.70)	540 (21.26)	600 (23.62)	-	-	-	X
49 310 54 121	400 (15.75)	450 (17.72)	820 (32.28)	-	-	-	X
49 311 54 101	400 (15.75)	450 (17.72)	900 (35.43)	-	-	-	X

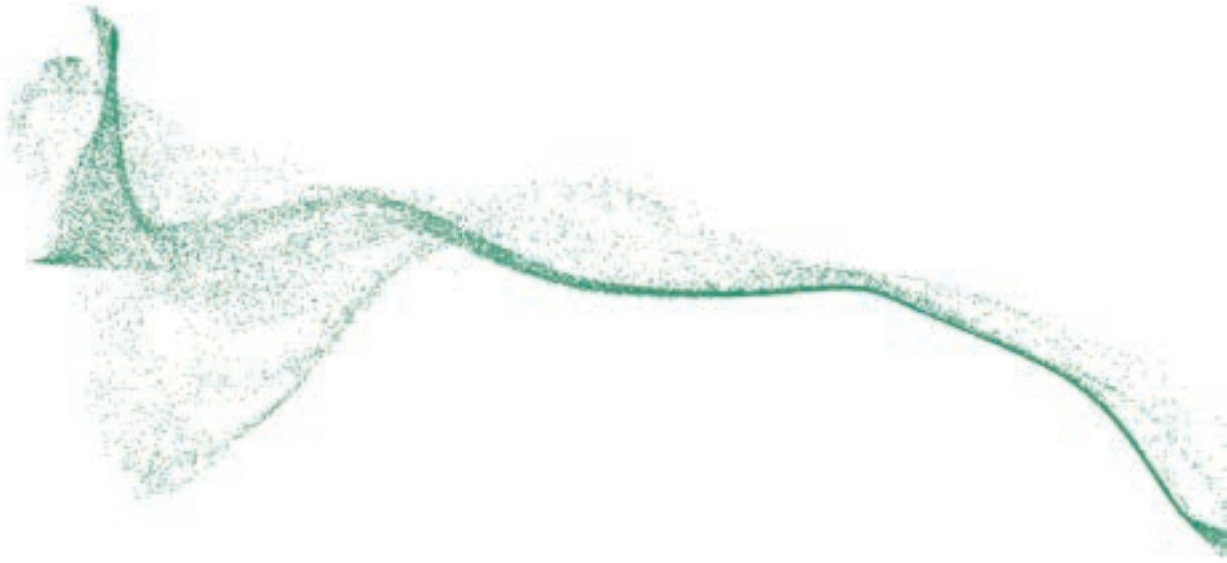

Air/oil separation for compressors

Spin-on separators



MANN+HUMMEL Spin-on separators for compressors

MANN+HUMMEL spin-on air/oil separators offer a solution which is easy to integrate and especially maintenance friendly for separation of the oil from compressed air within the compressor. They reliably remove oil and also return the separated oil back to the compressor which minimises the oil consumption of the compressor¹⁾. The combination with a MANN+HUMMEL filter head enables easy fitting and reliable maintenance.

Integration in the compressor

MANN+HUMMEL offers matching filter heads which enable easy integration in the system and connectors to help integration in a retainer provided by the customer. This ensures a reliable function for overhead and standing applications.

Specifications

- Max. oil content after preseparation approx. $<5 \text{ g/Nm}^3$
- Max. continuous operating temperature approx. $100 \text{ }^\circ\text{C}$, with peaks of $120 \text{ }^\circ\text{C}$
- Use of standard oils approved for compressors (ISO VG46)²⁾

Grounding

- All parts have the same electric potential (measured over the separator)
- Conductivity is tested in the production
- Electrical contact is made via the thread. The filter head is suitable for grounding.

Maintenance

- Observe the maintenance manual
- Lightly oil the seal before fitting
- Assemble with $\frac{1}{4}$ to $\frac{1}{2}$ turn after fitting the seal on the filter head (depends on thread, observe specification)

¹⁾ Depending on the respective application, the residual oil content in the compressed air may be subject to regulations. If necessary, the compressed air must be treated with suitable filters.

²⁾ If air/oil separators are used under strongly deviating ambient conditions, validation is necessary.

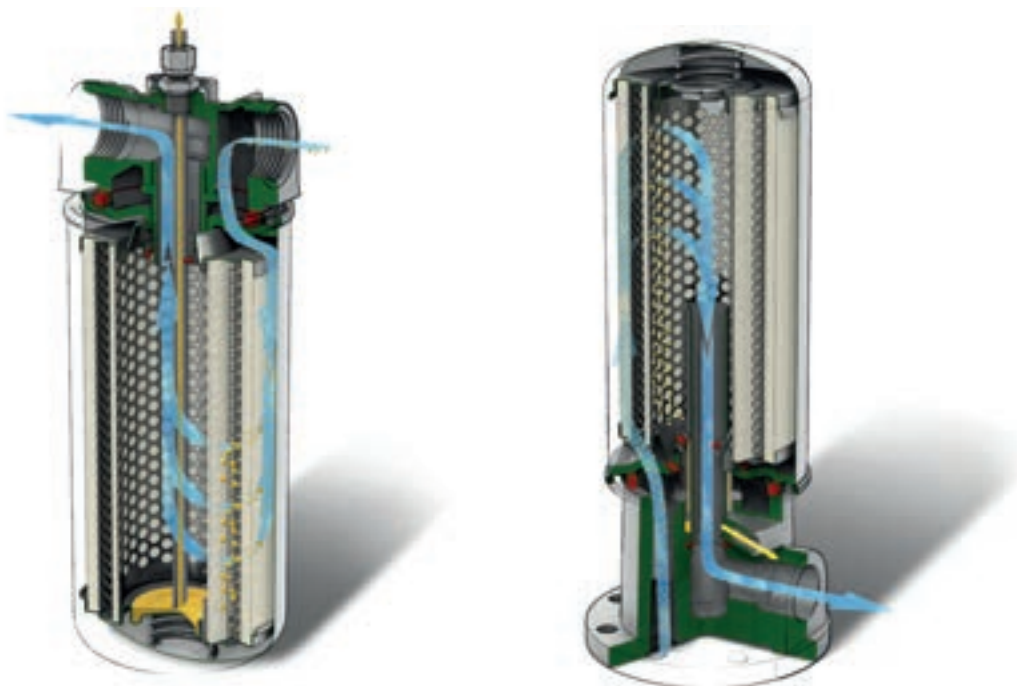

Spin-on separators

LB boxes

Reliability is decisively important for the sustainable function of machines and production lines and also essential for the qualitative reproducibility of high quality industrial goods. The MANN+HUMMEL LB boxes have proved themselves extensively on the market. They are a technically robust and attractively priced solution and are therefore an economic and calculable part of your process chain. They enable easy maintenance of your compressor system without long downtimes.

Specifications

- Residual oil content¹⁾: max. 3 mg/Nm³
- Initial pressure drop¹⁾: 0.25 bar
- Max. operating pressure: 20 bar (observe specification)
- Operating temperatures²⁾
Continuous³⁾: -20 °C to +100 °C
- For short periods³⁾: +120 °C
- Service life: max. 2,000 hrs / 1 bar Δp

¹⁾ At nominal load and 7 bar overpressure. Insufficient preseparation can negatively influence this value.

²⁾ Operating temperatures relate to the complete system of the spin-on air/oil separator.

³⁾ For short periods: the dwell time at the temperature permitted for short periods must not exceed 10 minutes. The time between 2 short-term peaks must be at least 30 minutes. After approx. 300 peaks have been reached we recommend changing the seal and filter.



LB boxes

Dimensions and order numbers

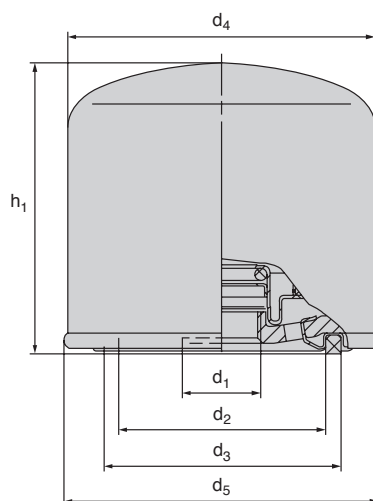

MANN-FILTER	Nominal flow ¹⁾ [m ³ /min] [cfm]	Dimensions in mm (<i>Dimensions in inches</i>)						Max. operating overpressure	
		d_1	d_2	d_3	d_4	d_5	h_1	[bar]	[MPa]
LB 719/2	1.0 [35.3]	M 22x1.5	62 (2.44)	71 (2.80)	76 (2.99)	80 (3.15)	127 (5.00)	20	2.0
LB 962/2	2.0 [70.7]	M 24x1.5	62 (2.44)	71 (2.80)	93 (3.66)	96 (3.78)	212 (8.35)	20	2.0
LB 1374/2	3.0 [106.0]	M 39x1.5	100 (3.94)	111 (4.37)	136 (5.35)	140 (5.51)	177 (6.97)	20	2.0
LB 11 102/2	4.0 [141.3]	M 32x1.5	93 (3.66)	104 (4.09)	108 (4.25)	110 (4.33)	260 (10.24)	14	1.4
LB 13 145/3	5.5 [194.3]	M 39x1.5	100 (3.94)	111 (4.37)	138 (5.43)	140 (5.51)	302 (11.89)	20	2.0

¹⁾ Nominal flow acc. to DIN 1945 at 7 bar [0.7 MPa] operating overpressure

Accessories

MANN-FILTER	Connector (Page 28)	Filter heads (Page 27)			FKM Seals (Page 29)
		Single	Dual	Triple	
LB 719/2	21 024 15 981	-	-	-	49 999 98 013
LB 962/2	21 027 15 991	-	-	-	49 999 98 013
LB 1374/2	21 042 15 991	67 700 31 801	67 730 31 861	67 750 31 971	49 999 98 014
LB 11 102/2	21 036 15 991	-	-	-	-
LB 13 145/23	21 042 15 991	67 700 31 801	67 730 31 861	67 750 31 971	49 999 98 014

Spin-on separators

StarBox

High quality air/oil separators are extremely important for the process reliability and energy efficiency of compressors. The StarBox from MANN+HUMMEL sets new standards in both these areas for the separation of compressed air containing oil and simultaneously offers a higher performance in the same installation space. This is made possible by a new, high performance medium specially developed for compressors. This allows StarBox to perform better than conventional air/oil boxes in the decisive areas of residual oil content and differential pressure.

The advantages at a glance:

- Up to 99 euros of energy saved per filter through lower differential pressure
- Residual oil content of 1 to 3 ppm
- Up to 25 % longer service life in comparison to conventional air/oil boxes
- Longer life of fine filters fitted downstream

The StarBox enables economic operation of the compressor at the same volume flow rate. With a higher volume flow rate and the same ancillary conditions (pressure, volume flow rate) it can also be used in the same way as a conventional LB Box.

Specifications

- Residual oil content¹⁾: max. 2 mg/Nm³
- Initial pressure drop¹⁾: 0.21 bar
- Max. operating pressure: 20 bar (observe specification)
- Operating temperatures²⁾
Continuous³⁾: -20 °C up to +100 °C
- For short periods³⁾: +120 °C
- Service life: max. 2,500 hrs / 1 bar Δp

¹⁾ At nominal load and 7 bar overpressure. Insufficient preseparation can negatively influence this value.

²⁾ Operating temperatures relate to the complete system of the spin-on air/oil separator.

³⁾ For short periods: the dwell time at the temperature permitted for short periods must not exceed 10 minutes. The time between 2 short-term peaks must be at least 30 minutes. After approx. 300 peaks have been reached we recommend changing the seal and filter.



StarBox

Dimensions and order numbers

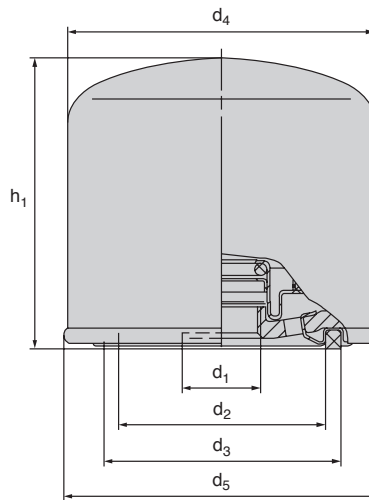

MANN-FILTER	Nominal flow ¹⁾ [m ³ /min] [cfm]	Dimensions in mm (<i>Dimensions in inches</i>)						Max. operating overpressure	
		d_1	d_2	d_3	d_4	d_5	h_1	[bar]	[MPa]
LB 719/20	1.1 [38.8]	M 22x1.5	62 (2.44)	71 (2.80)	76 (2.99)	80 (3.15)	127 (5.00)	20	2.0
LB 962/20	2.2 [77.7]	M 24x1.5	62 (2.44)	71 (2.80)	93 (3.66)	96 (3.78)	212 (8.35)	20	2.0
LB 1374/20	3.3 [116.5]	M 39x1.5	100 (3.94)	111 (4.37)	136 (5.35)	140 (5.51)	177 (6.97)	20	2.0
LB 11 102/20	4.4 [155.3]	M 32x1.5	93 (3.66)	104 (4.09)	108 (4.25)	110 (4.33)	260 (10.24)	14	1.4
LB 13 145/20	6.0 [211.8]	M 39x1.5	100 (3.94)	111 (4.37)	138 (5.43)	140 (5.51)	302 (11.89)	20	2.0

¹⁾ Nominal flow acc. to DIN 1945 at 7 bar [0.7 MPa] Operating overpressure

Accessories

MANN-FILTER	Connector (Page 28)	Filter heads (Page 27)			FKM Seals (Page 29)
		Single	Dual	Triple	
LB 719/20	21 024 15 981	–	–	–	49 999 98 013
LB 962/20	21 027 15 991	–	–	–	49 999 98 013
LB 1374/20	21 042 15 991	67 700 31 801	67 730 31 861	67 750 31 971	49 999 98 014
LB 11 102/20	21 036 15 991	–	–	–	–
LB 13 145/20	21 042 15 991	67 700 31 801	67 730 31 861	67 750 31 971	49 999 98 014

Air/oil separation for compressors

Accessories for spin-on separators

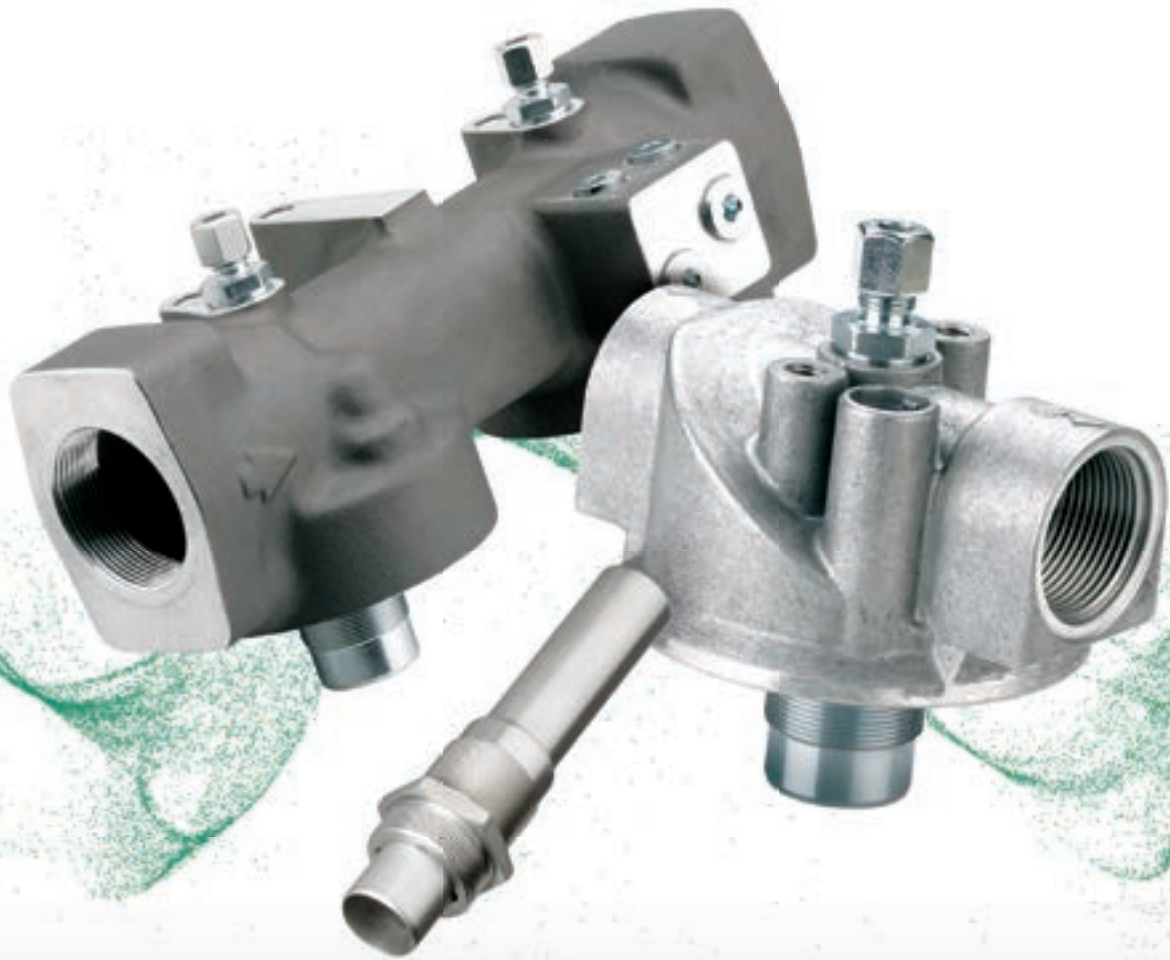

Accessories for spin-on air/oil separators

Filter heads



MANN+HUMMEL spin-on air/oil separators function best when they are positioned above or below the filter head. In these positions the separated oil can be ideally collected in the provided reservoir or drained via the connector.

A selection of MANN+HUMMEL filter heads are available which enable a standard solution for easy integration in the compressor. These allow fitting below the filter head.

When selecting the filter head and spin-on air/oil separator care should be taken to ensure that the respectively lowest given operating pressure is not exceeded.

The oiled air is directed to the MANN+HUMMEL spin-on air/oil separator through the inlet port of the filter head and the de-oiled air leaves the filter head via the opposite side. The arrow direction must be observed. The separated oil is pressed out of the filter head via the scavenge line (not included in the scope of delivery) and leaves the filter.

Accessories for spin-on air/oil separators

Filter heads

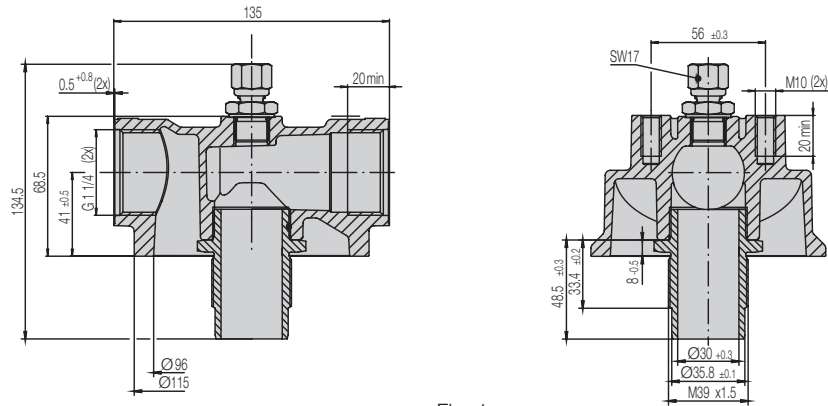

Fig. 1

Order no.	Name	Fig.	Suitable for LB-Box / StarBox	Max. operating overpressure	
				[bar]	[MPa]
67 700 31 801	Single	1	LB 1374/2		
67 730 31 861	Dual	2	LB 1374/20	20	2,0
67 750 31 971	Triple	3	LB 13 145/3 LB 13 145/20		

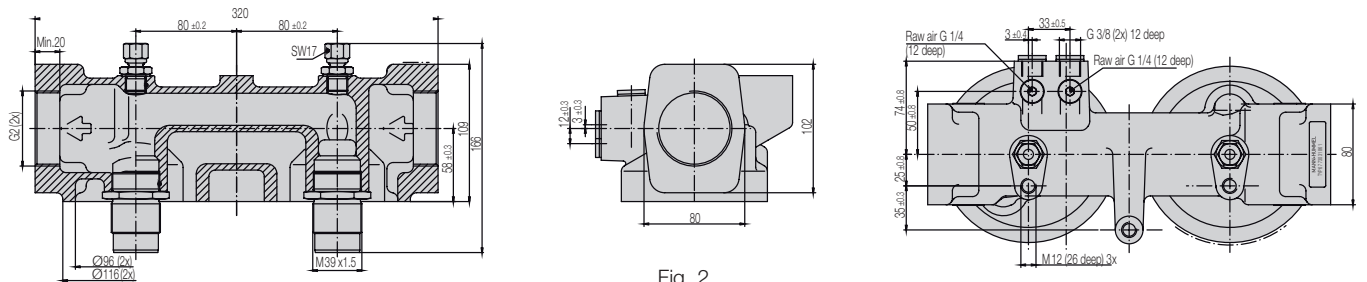

Fig. 2

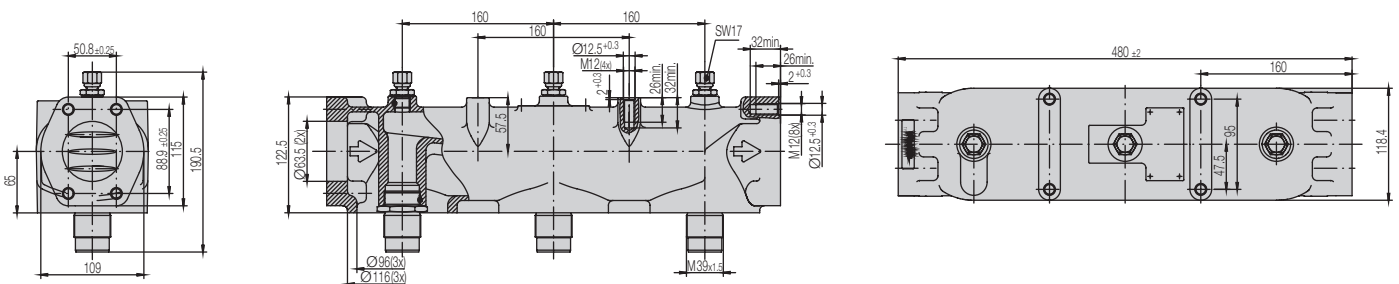
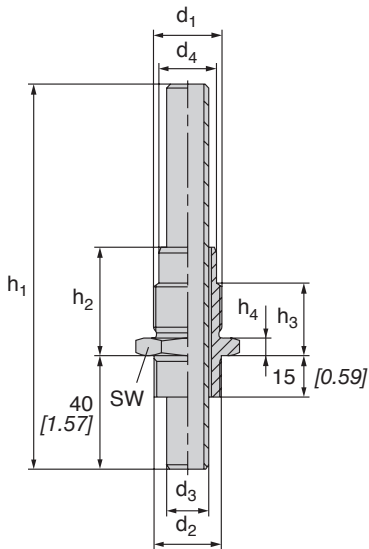

Fig. 3

Accessories for spin-on separators

Screwed-on connectors

A MANN+HUMMEL connector can be used if integration is required in a customised connection structure. This enables the separate discharge of the oil and the de-oiled air.



Order no.	Suitable for LB-Box / StarBox	Dimensions in mm (<i>Dimensions in inches</i>)								
		d ₁	d ₂	d ₃	d ₄	h ₁	h ₂	h ₃	h ₄	SW
21 024 15 981	LB 719/2	M 22x1.5	M 24x1.5	14 (0.55)	19.2 (0.76)	135 (5.31)	38 (1.50)	25.4 (1.00)	6 (0.24)	27 (1.06)
	LB 719/20									
21 027 15 991	LB 950/20	M 24x1.5	M 27x1.5	15 (0.59)	19.8 (0.74)	135 (5.31)	38 (1.50)	25.4 (1.00)	6 (0.24)	32 (1.26)
	LB 962/2									
	LB 962/20									
21 036 15 991	LB 11 102/2	M 32x1.5	M 36x1.5	22 (0.87)	28.1 (1.11)	155 (6.10)	41.5 (1.63)	27.4 (1.08)	6 (0.24)	41 (1.61)
	LB 11 102/20									
21 042 15 991	LB 13 145/3	M 39x1.5	M 42x1.5	30 (1.18)	35.8 (1.41)	175 (6.89)	47.5 (1.87)	34.4 (1.35)	7 (0.28)	46 (1.81)
	LB 13 145/20									

Accessories for spin-on separators

Replacement seals

Standard spin-on air/oil separators are supplied with a main seal in NBR material (nitrile rubber). This proven material enables continuous operation at approx. 90 °C. If the oil temperature during operation of the compressor continuously exceeds or repeatedly for a long time exceeds this value, we recommend changing the main seal over to FKM (fluorinated rubber). Seals in FKM should not be used during operation of a compressor below the minimum temperature.

Delivery description

The packaging unit for the given reference number includes 20 replacement seals.

Replacing a seal

In order to change the seal pull out the existing seal from the holder on the underside of the spin on air/oil separator and insert the replacement seal. Take care the seal is positioned completely against the retaining slot.

Specifications

- Material: FKM
- Operating temperatures¹⁾
 Continuous²⁾: -20 °C to +100 °C,
 For short periods²⁾: +120 °C

¹⁾ Operating temperatures relate to the complete system of the spin-on air/oil separator.

²⁾ For short periods: the dwell time at the temperature permitted for short periods must not exceed 10 minutes. The time between 2 short-term peaks must be at least 30 minutes. After approx. 300 peaks have been reached we recommend changing the seal and filter.

Order no.	Name	Suitable for LB Box/StarBox
49 999 98 013	Service kit size 7+9	LB 7 LB 9
49 999 98 014	Service kit size 13	LB 13



MANN+HUMMEL Oil filters for use in compressors

Standard, Long life and High pressure oil filters,
Accessories



MANN+HUMMEL oil filters for compressors

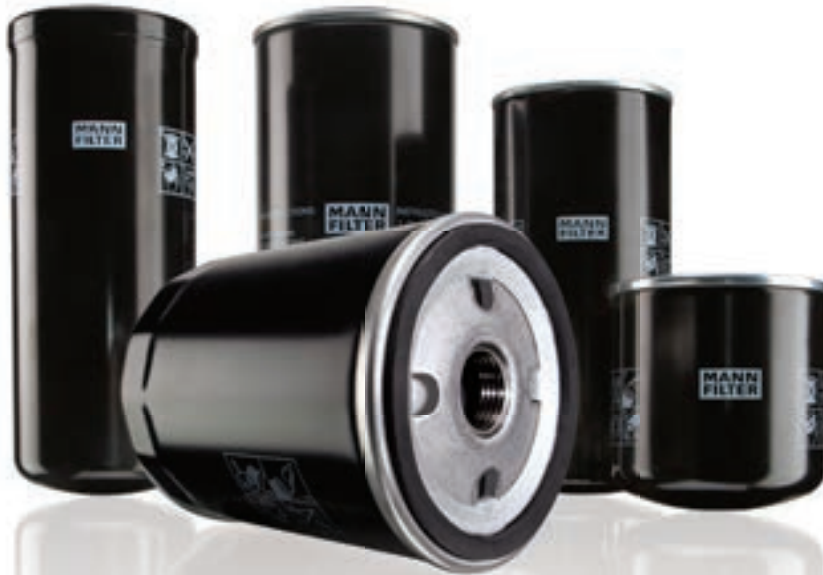

Compressors place special demands on oil filters and coolant filters with regard to materials and design. The following listed oil filters exclusively use materials which have been tested for use in compressors.

MANN+HUMMEL offers “Standard” oil filters, “Long life” oil filters and “High pressure” oil filters.

Standard oil filters are equipped with a cellulose medium and are suitable for a change interval of 2,000 hrs.

Long life oil filters offer security with more demanding requirements. These oil filters are equipped with a fibre-glass medium which combines resistance to aggressive compressor oils with a high separation efficiency. These filters allow an operating time of up to 4,000 hrs. They are also less sensitive to pulsation influences than the standard version.

High pressure filters are recommended for applications where the operating pressure is expected to be higher than 14 bar.

Design

MANN+HUMMEL spin-on filters consist of a robust metal housing with integrated filter element. Depending on the application, the spin-on filter can be equipped with different components such as filter medium, by-pass valve, etc.. The liquid to be filtered enters the concentrically arranged inlet port on the top, flows through the filter element and in a clean state passes out through the central connection. An undetachable seal located in the cover ensures reliable sealing to the outside under all operating conditions.

The advantages at a glance:

- Available with different filter media
- Efficient separation and high dirt holding capacity with low pressure drop
- Robust, corrosion-free housing with high resistance to pulsations and high pressure stability
- Advanced flow design geometry
- Bypass valves with clearly defined opening characteristics and leakage-free closing
- Undetachable seals
- Stable, collapse-resistant centre tube

Standard oil filters for compressors

Dimensions and order numbers

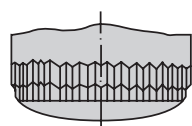

Design B

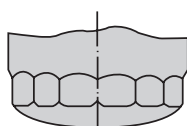

Design C

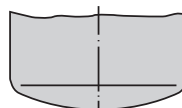

Design E

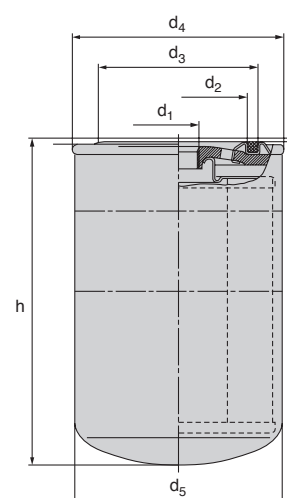

MANN-FILTER	Nominal flow	Dimensions in mm (<i>Dimensions in inches</i>)						Bypass valve [bar]	Permissible operating pressure		Design
	[l/min] [gpm]	d ₁	d ₂	d ₃	d ₄	d ₅	h		[bar]	[MPa]	
WD 940/2	50 [13]	1"-12 UNF	62 (2.44)	71 (2.80)	96 (3.78)	93 (3.66)	144 (5.67)	2.5	25	2.5	E
W 950/31	60 [16]	1"-12 UNF	62 (2.44)	71 (2.80)	96 (3.78)	93 (3.66)	170 (6.69)	2.0	14	1.4	B
WD 962/8	75 [20]	1"-12 UNF	62 (2.44)	71 (2.80)	96 (3.78)	93 (3.66)	210 (8.27)	2.5	25	2.5	E
W 962/14	75 [20]	1"-12 UNF	62 (2.44)	71 (2.80)	96 (3.78)	93 (3.66)	210 (8.27)	2.5	14	1.4	B
W 11 102/16	100 [26]	1 1/8"-16 UNF	93 (3.66)	104 (4.09)	110 (4.33)	108 (4.25)	260 (10.24)	2.5	14	1.4	C
WD 13 174/4	180 [48]	1 1/2"-16 UN	100 (3.94)	111 (4.37)	140 (5.51)	136 (5.35)	302 (11.89)	2.5	20	2.0	E

Filter fineness acc. to ISO 16889 [µm (c)], 50 % = 14 / 99 % = 38, service life approx. 2,000 hrs

Accessories

MANN-FILTER	Filter heads (Page 37 - 39)				FKM Seals (Page 43)
	Single	Dual	Triple	Switchable	
WD 940/2	67 506 31 143 67 506 31 535	67 512 31 851	-	-	49 999 98 013
W 950/31	67 506 31 143 67 506 31 535	67 512 31 851	-	-	49 999 98 013
WD 962/8	67 506 31 143 67 506 31 535	67 512 31 851	-	-	49 999 98 013
W 962/14	67 506 31 143 67 506 31 535	67 512 31 851	-	-	49 999 98 013
W 11 102/16	-	67 625 31 935	-	67 612 31 791	-
WD 13 174/4	67 700 31 934	67 730 31 129	67 750 31 991	-	49 999 98 014

Long life oil filters and high pressure oil filters for compressors

Dimensions and order numbers

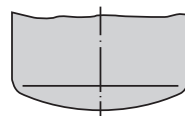
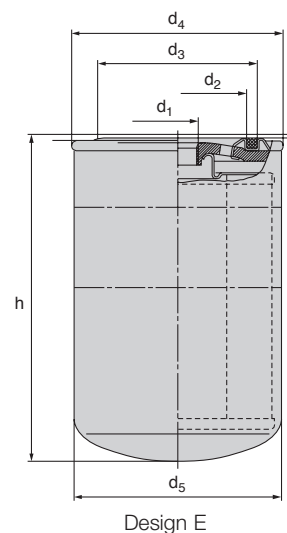

Design E

Design E

Long life

MANN-FILTER	Nominal flow	Dimensions in mm (<i>Dimensions in inches</i>)						Bypass valve	Permissible operating pressure		Design
	[l/min] [gpm]	d ₁	d ₂	d ₃	d ₄	d ₅	h		[bar]	[bar]	
WD 962/21	65 [17]	1"-12 UNF	62 (2.44)	71 (2.80)	96 (3.78)	93 (3.66)	210 (8.27)	2.5	25	2.5	E
WD 13 145/14	210 [56]	1 ½"-16 UN	100 (3.94)	111 (4.37)	140 (5.51)	136 (5.35)	302 (11.89)	2.5	20	2.0	E
WD 1374/6	95 [25]	1 ½"-16 UN	100 (3.94)	111 (4.37)	140 (5.51)	136 (5.35)	177 (6.97)	2.5	20	2.0	E

Filter fineness acc. to ISO 16889 [µm (c)], 50 % = 14 / 99 % = 10, service life approx. 4,000 hrs

Long life Accessories

MANN-FILTER	Filter heads (Page 37 - 39)				FKM Seals (Page 43)
	Single	Dual	Triple	Switchable	
WD 962/21	67 506 31 143 67 506 31 535	67 512 31 851	-	-	49 999 98 013
WD 1374/6 WD 13 145/14	67 700 31 934	67 730 31 129	67 750 31 991	-	49 999 98 014

High pressure

MANN-FILTER	Nominal flow	Dimensions in mm (<i>Dimensions in inches</i>)						Bypass valve	Permissible operating pressure		Design
	[l/min] [gpm]	d ₁	d ₂	d ₃	d ₄	d ₅	h		[bar]	[bar]	
WH 945/2	70 [19]	1 ⅜"-12 UNF	-	-	97 (3.82)	94.2 (3.71)	152 (5.98)	-	34.5	3.45	E
WH 980/3	100 [26]	1 ⅜"-12 UNF	-	-	97 (3.82)	94.2 (3.71)	240 (9.45)	-	34.5	3.45	E

Filter fineness acc. to ISO 16889 [µm (c)], 50 % = 14 / 99 % = 10, service life approx. 4,000 hrs

Oil filters for compressors

Accessories

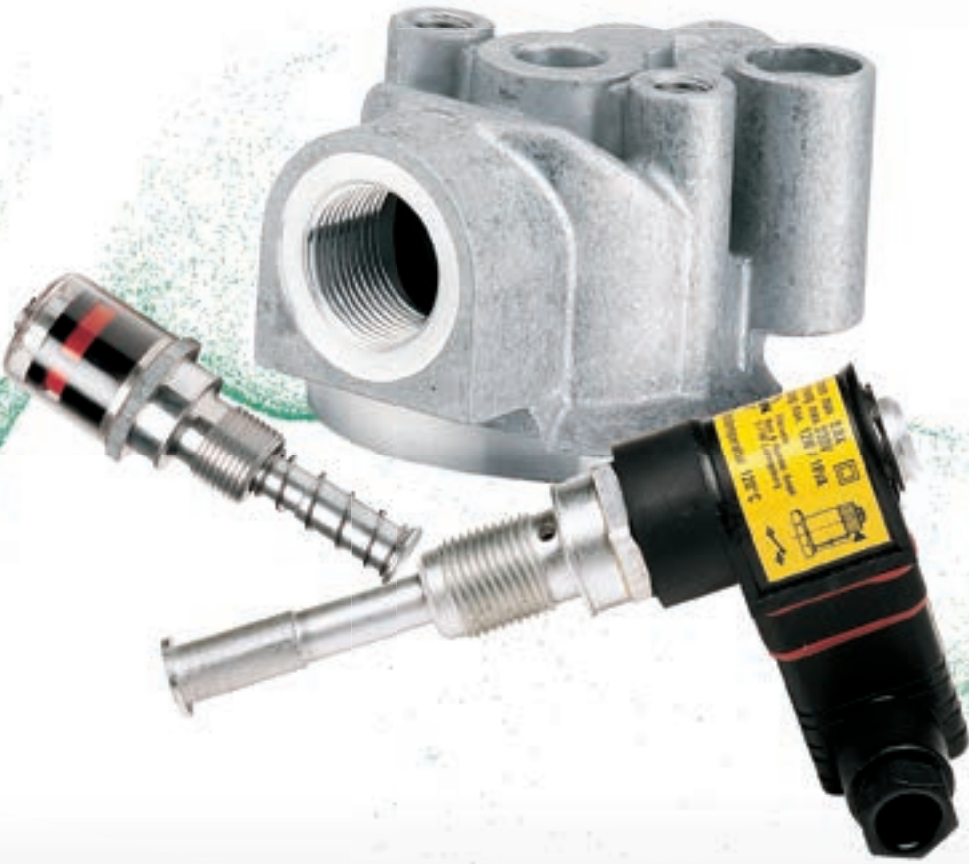

Accessories for oil filters

Filter heads



A selection of MANN+HUMMEL filter heads is available which enables a standard solution for easy integration in the compressor. These allow the easy fitting and maintenance of oil filters. When selecting the filter head and oil filter, care should be taken to ensure that the respectively lowest given operating pressure is not exceeded.

The oil is directed to the MANN+HUMMEL oil filter through the inlet port of the filter head and the de oiled air leaves the filter head via the opposite side. The arrow direction must be observed.

If the specified volume flow of an individual oil filter is not sufficient, the use of a multi-head is possible to cover the requirement of the compressor.

If maintenance is necessary during operation, a switchable filter head can be used. During maintenance this enables the switching of a single filter to be free of pressure so that it can be replaced. It is necessary to observe, however, that as a result the whole oil flow will then flow through only one filter and therefore the pressure in the system will increase accordingly. This must be taken into account when designing the system.

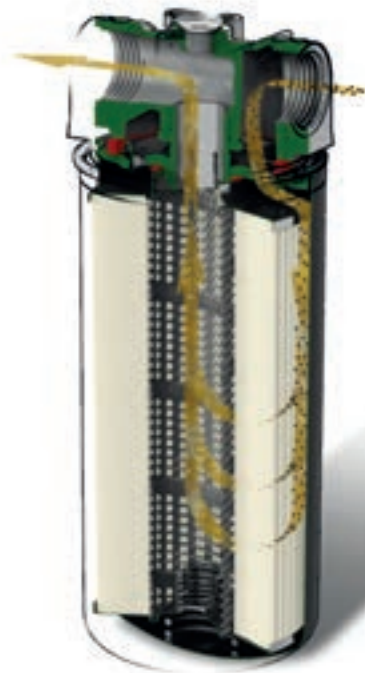

Accessories for oil filters

Filter heads

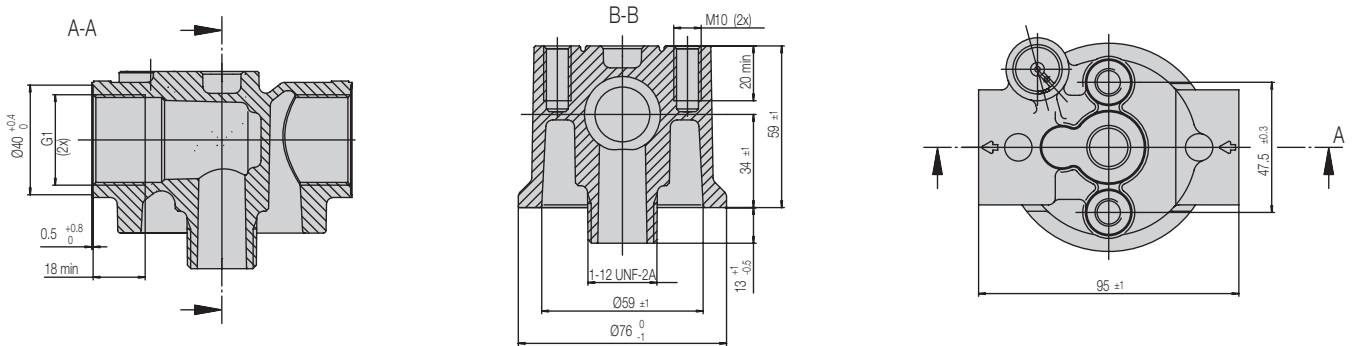

Fig. 1

Order no.	Name	Fig.	Suitable oil filter	Max. operating overpressure		Thread Filter	Pipe connection	Service switch
				[bar]	[MPa]			
67 506 31 143	Single	1	W / WD 7 W / WD 9	14	1,4	1-12 UNF-2A	G 1	-
67 506 31 535	Single	2	W / WD 7 W / WD 9	25	2,5	1-12 UNF-2A	G 3/4	-
67 700 31 934	Single	3	W / WD 13	20	2,0	1 1/2-16 UN-2A	G 1 1/4	necessary ¹⁾

¹⁾ Filter head can only be used together with service switch.

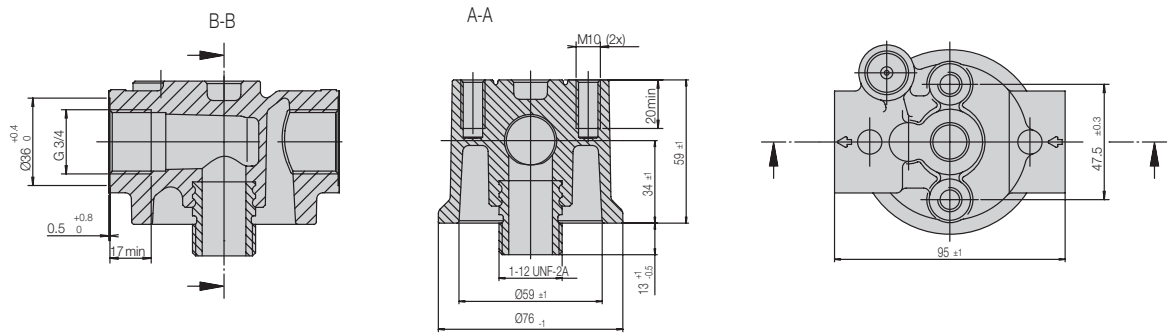

Fig. 2

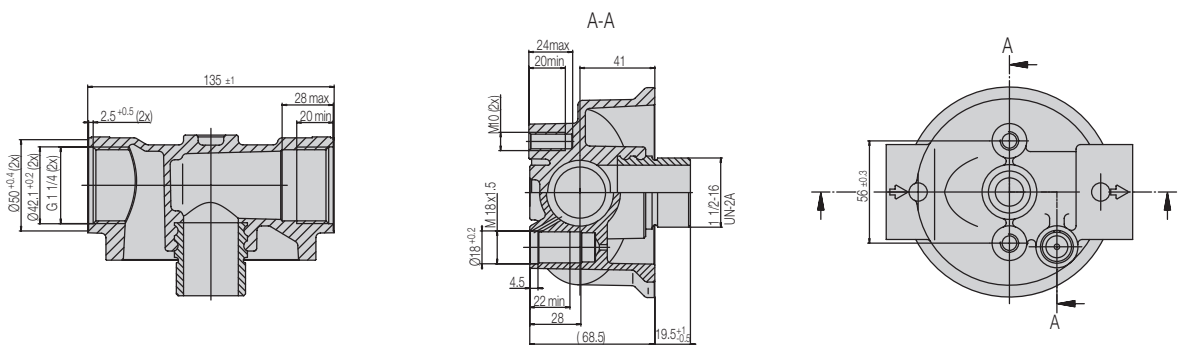

Fig. 3

Accessories for oil filters

Dual filter heads

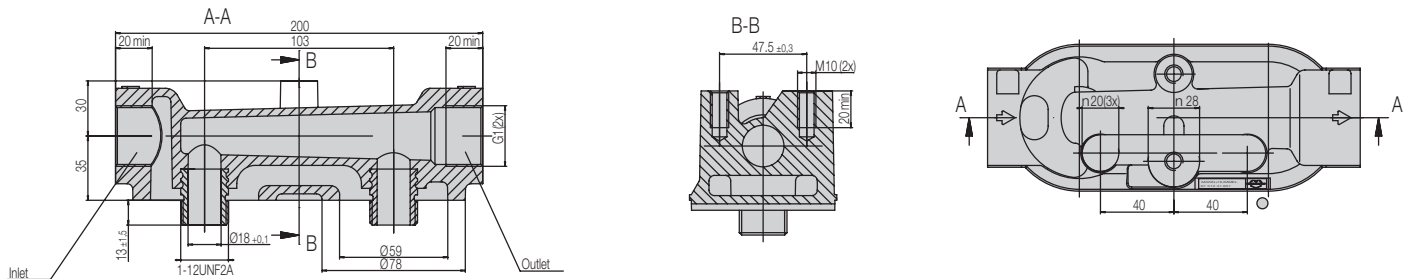

Fig. 1

Order no.	Name	Fig.	Suitable oil filter	Max. operating overpressure		Thread Filter	Pipe connection	Service switch
				[bar]	[MPa]			
67 512 31 851	Dual	1	W / WD 7 W / WD 9	25	2.5	1-12 UNF-2A	G 1	-
67 625 31 935	Dual	2	W / WD 11	15	1.5	1 1/8-16 UN-2A	G 1 1/2	possible
67 730 31 129	Dual	3	W / WD 13	20	2.0	M 38x1.5 (internal)	G 1 1/4	possible

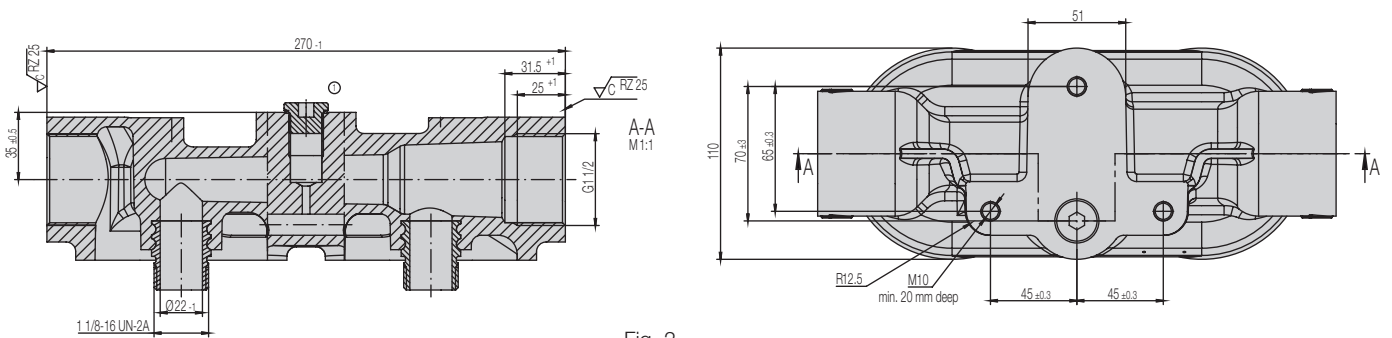

Fig. 2

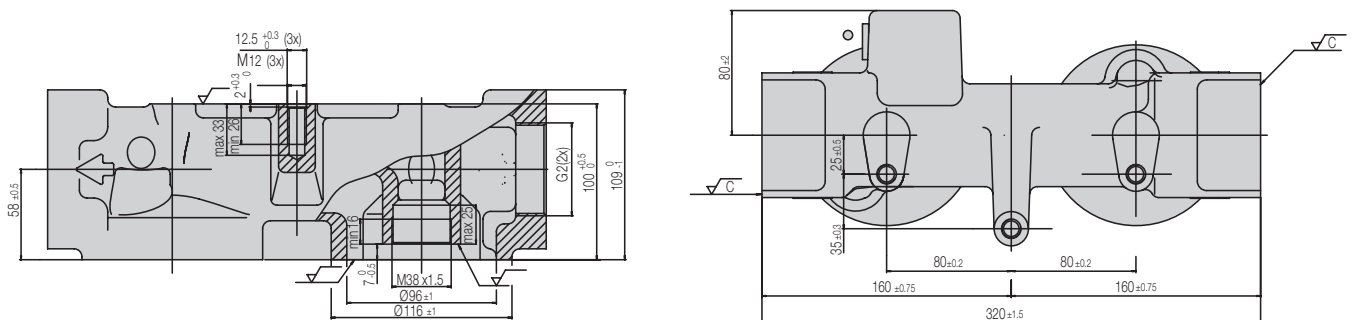

Fig. 3

Accessories for oil filters

Tripe filter heads / Switches

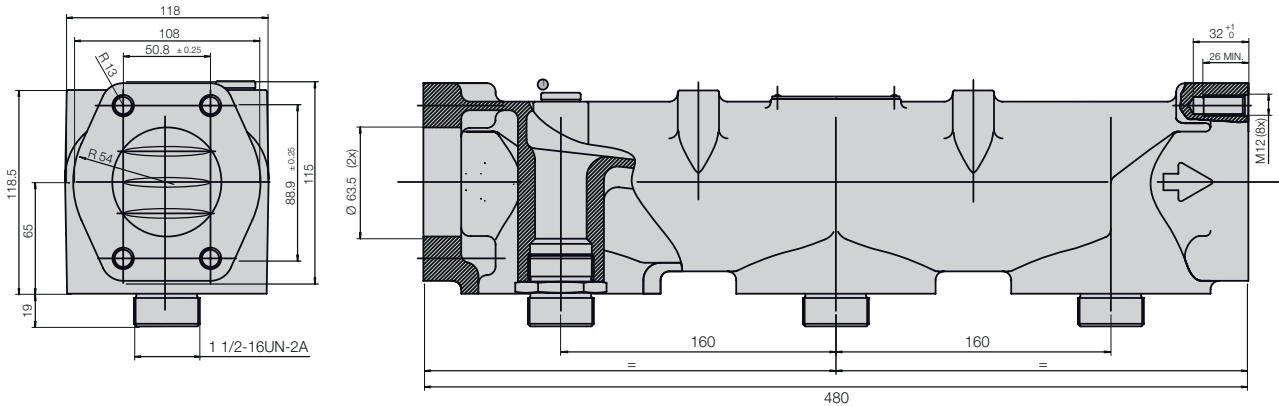

Fig. 1

Order no.	Name	Fig.	Suitable oil filter	Max. operating overpressure		Thread Filter	Pipe connection	Service switch
				[bar]	[MPa]			
67 750 31 991	Triple	1	W / WD 13	20	2.0	1 1/2-16 UN-2A	Flange	possible
67 506 31 551	switchable	2	W / WD 7 W / WD 9	25	2.5	1-12UNF-2A	M 30x1.5	possible
67 612 31 791	switchable	3	W / WD 11	10	1.0	1-12UNF-2A	M 30x1.5	possible

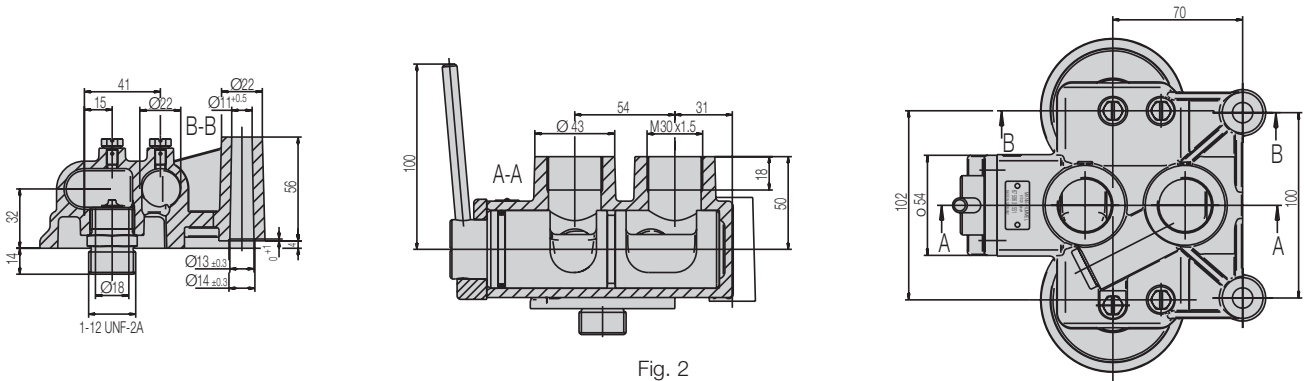

Fig. 2

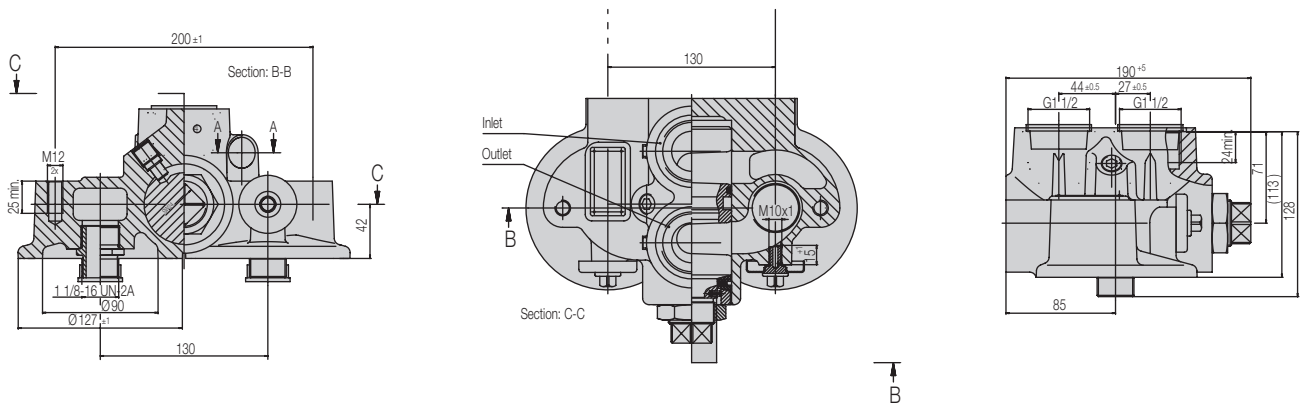
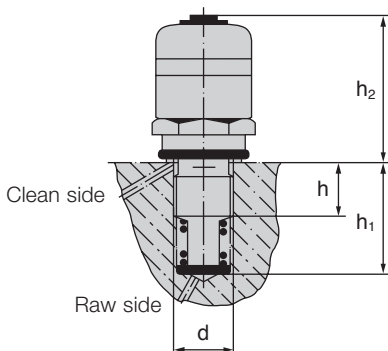

Fig. 3

Accessories for oil filters

Visual service indicator

MANN+HUMMEL service indicators signal the time for maintenance for filter inserts full of dirt particles by the display of a red signal ring in a display. The permissible operating temperature is 120 °C.



Order no.	Dimensions in mm (<i>Dimensions in inches</i>)				Max. pressure [bar]	Switching pressure [bar]	Suitable for
	d	h	h ₁	h ₂			
59 020 79 201	M 18x1.5	22 (0.87)	36 (1.42)	46 (1.81)	25	1.0	67 700 31 934 67 625 31 935
59 020 79 208	M 18x1.5	22 (0.87)	36 (1.42)	46 (1.81)	25	1.4	67 730 31 129 67 750 31 991
59 020 79 202	M 18x1.5	22 (0.87)	36 (1.42)	46 (1.81)	25	1.8	67 506 31 551 67 612 31 791

Accessories for oil filters

Service switches

When the time for maintenance has come an electromagnetic switch actuates a signal (e.g. lamp, buzzer) or a disconnection device.

- Operating temperature: max. 120 °C
- Switching type: the default switching type is listed in the table below (make / break contact).
The customer can change the setting by rearranging the contacts.
- Switching capacity: max. 12 W / 18 VA
- Starting current: max. 0.8 A
- Protection class: IP 65 all-insulated

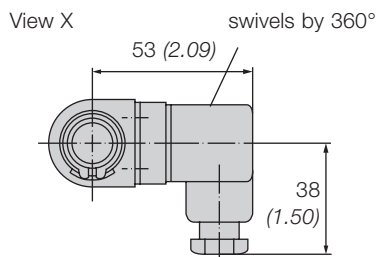

Connection for cable diameter
4.5 up to 7 mm (0.18 up to 0.28 inches)

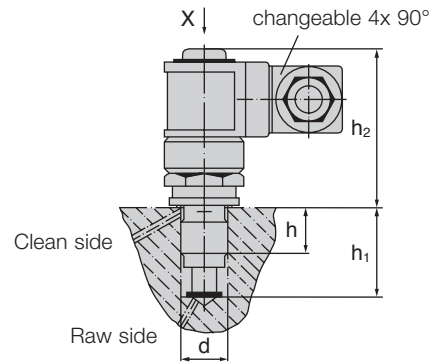

Order no.	Dimensions in mm (<i>Dimensions in inches</i>)				Max. pressure [bar]	Switching pressure [bar]	Contact type	Suitable for
	d	h	h ₁	h ₂				
59 010 79 206	M 18x1.5	22 (0.87)	36 (1.42)	62.5 (2.46)	25	0.8	Break contact	67 700 31 934
59 010 79 201	M 18x1.5	22 (0.87)	36 (1.42)	62.5 (2.46)	25	1.0	Make contact	67 625 31 935 67 730 31 129
59 010 79 208	M 18x1.5	22 (0.87)	36 (1.42)	62.5 (2.46)	25	1.4	Make contact	67 750 31 991 67 506 31 551
59 010 79 202	M 18x1.5	22 (0.87)	36 (1.42)	62.5 (2.46)	25	1.8	Make contact	67 612 31 791

Accessories for oil filters

Service switches

Instructions for electrical installation of the service switch

The service switch is equipped with a high quality electromagnetic switch (reed switch). In order to achieve a reliable function, please observe the following:

1. For an electrical or optical display we recommend use of a glow lamp or LED. Both can be directly switched without a spark quenching device.
2. Filament lamps require a very high starting current relative to their load current. The lamp and a series resistor should be dimensioned such that the maximum load of the switch (see rating plate) is not exceeded when switching on. We recommend selecting the series resistor such that the switch has the max. load without consideration of the glow lamp resistance. It is thereby protected against overload but the glow lamp lights up with low voltage.
3. When switching inductive loads voltage peaks can be induced which in some circumstances may cause the service switch to malfunction. For alternating current an RC combination should be connected parallel to the relay or contactor coil and with direct current a freewheeling diode (e.g. diode 1 N 4007) in reverse direction.

When dimensioning the spark quenching device the instructions of the respective contactor or relay should be observed.

In both cases the maximum load for the switch (see rating plate) must not be exceeded.

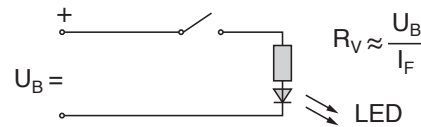
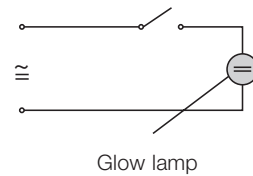

Dimension the RV so that IF is approx. 15 ... 20 mA

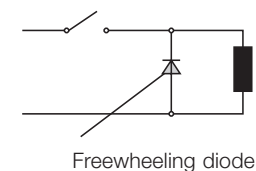
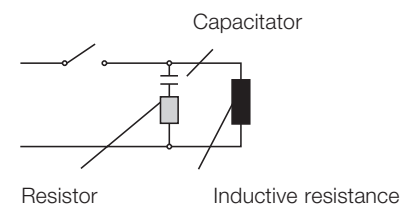
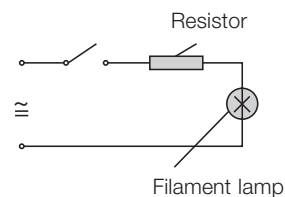

Accessories for oil filters

Replacement seals



Standard spin-on air/oil separators are supplied with a main seal in NBR material (nitrile rubber). This proven material enables continuous operation at approx. 100 °C. If the oil temperature during operation of the compressor continuously exceeds or repeatedly for a long time exceeds this value, we recommend changing the main seal over to FKM (fluorinated rubber). Seals in FKM should not be used during operation of compressors below the minimum temperature.

Delivery description

The packaging unit for the given reference number includes 20 replacement seals.

Replacing a seal

In order to change the seal pull out the existing seal from the holder on the underside of the oil filter and insert the replacement seal. Take care the seal is positioned completely against the retaining slot.

Specifications

- Material: FKM
- Operating temperatures¹⁾
Continuous²⁾: -20 °C to +100 °C,
For short periods²⁾: +120 °C

¹⁾ Operating temperatures relate to the complete system of the oil filter.

²⁾ For short periods: the dwell time at the temperature permitted for short periods must not exceed 10 minutes. The time between 2 short-term peaks must be at least 30 minutes. After approx. 300 peaks have been reached we recommend changing the seal and filter.

Order no.	Name	Suitable for filter type
49 999 98 013	Service kit size 7+9	W / WD 7 W / WD 9
49 999 98 014	Service kit size 13	W / WD 13



MANN+HUMMEL Air cleaners for use in compressors

IQORON, ENTARON, EUROPICLON, NLG,
Picolino, Picolight, Accessories



MANN+HUMMEL Air cleaners for use in compressors

Modern, high performance compressors require filters and components with a correspondingly high performance. The selection shown here provides an overview of our air cleaners and matching accessories – naturally in the well-known MANN+HUMMEL OEM quality. It is a matter of course for MANN+HUMMEL to offer individual concepts and problem solutions for special requirements.



IQORON series
From page 47



ENTARON series
From page 53



EUROPICLON series
From page 61



NLG series
From page 75



Picolino series
From page 87



Picolight series
From page 95



**System accessories
for air cleaners**
From page 99

Air cleaners for compressors

IQORON series



IQORON-S

Single-stage filter

The IQORON-S is suitable for use with all applications where very low pressure drop is a requirement. This is naturally especially true for compressors, but also includes stationary engines used for energy generation and machines which operate in low dust conditions. This is where the IQORON-S shows its strength – with a very low pressure drop.

The IQORON-S can be converted to an IQORON-V at any time if the dust conditions make this necessary: simply remove the raw air grid and replace it with the precleaner.

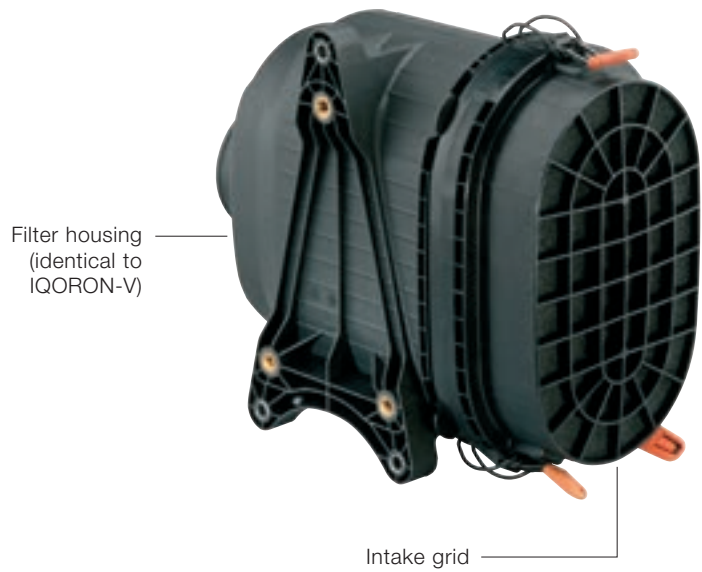

Dimensions and part numbers

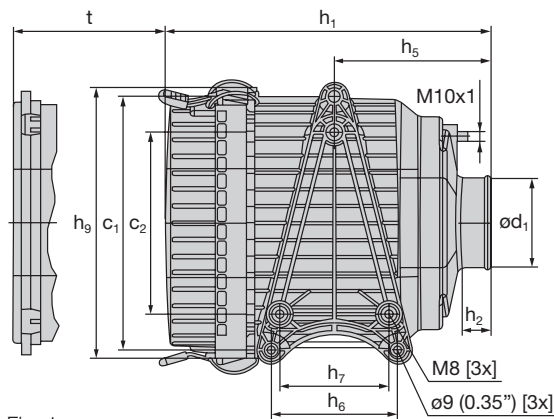

Fig. 1

Filter size	Nominal flow [m³/min]	Fig.	Order no.		Replacement filter element		Weight [kg]
			without secondary element	with secondary element	MANN-FILTER main element	MANN-FILTER secondary element	
IQORON-S 7	4 - 10	1	45 270 75 912	45 270 75 910	C 26 270	CF 2125/1	2.7

Filter size	Dimensions in mm (Dimensions in inches)										
	b	c ₁	c ₂	d ₁	h ₁	h ₂	h ₅	h ₆	h ₇	h ₉	t
IQORON-S 7	176.4 (6.95)	250 (9.84)	180 (7.09)	89.1 (3.51)	324 (12.76)	30 (1.18)	155 (6.10)	125 (4.92)	108 (4.25)	267.9 (10.55)	105 (4.13)

IQORON-V

Two-stage filter



IQORON-V 9

Housing made from fibre-glass reinforced plastic with integrated fixing points (M8 threaded inserts – option: M10 or UNC 3/8"-16 – and through-holes for M8 screws)

Cyclone precleaner

Fasteners for axial element removal without hinge

Dust discharge valve



IQORON-V 7

The IQORON-V is the ideal filter for all machines which require high reliability under heavy dust conditions. These are, for example, construction and agricultural machines and mobile compressors. Other applications also include machines and vehicles in horticulture and landscaping, as well as forklifts. The cyclone preseparator offers excellent pre-separation.

The IQORON-V achieves a pre-separation efficiency of 95 % with scavenging and 90 % without scavenging (with SAE coarse).

Two different positions for the dust discharge port enable the filter to be fitted position.

The precleaner can easily be cleaned should it become clogged during operation.

IQORON-V installation positions

The IQORON-V is available in two versions: for a horizontal or vertical fitting position. During installation make sure that the angle deviation of the dust valve to the vertical is not more than 15°. If the filter is operated with scavenging, a deviation of max. 45° to the vertical is permissible.

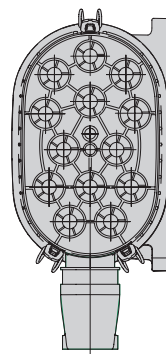

Vertical fitting
Fig. 1

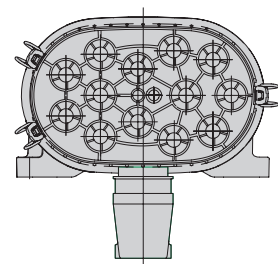

Horizontal fitting
Fig. 2

Filter size	Nominal flow [m³/min]	Fig.	Order no.		Replacement filter element		Weight [kg]
			without secondary element	with secondary element	MANN-FILTER main element	MANN-FILTER secondary element	
IQORON-V 7	4 - 7	1	45 270 95 912	45 270 95 910	C 26 270	CF 2125/1	3.1
		2	45 270 95 913	45 270 95 911			
IQORON-V 9	5 - 9	3	45 402 95 914	45 402 95 910*	C 30 400/1	CF 2631	4.8
		4	45 402 95 915	45 402 95 911			
		3	45 402 95 916	45 402 95 912			
		4	45 402 95 917	45 402 95 913**			

* Cover and dust discharge valve on the same side

** Cover on the left side

IQORON-V

Dimensions and part numbers

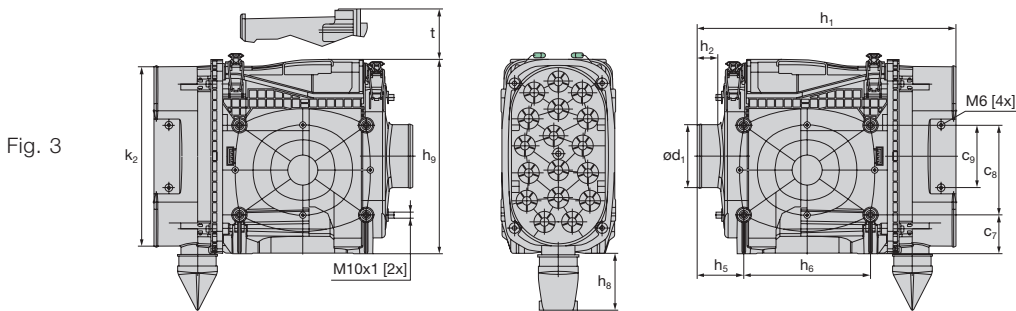
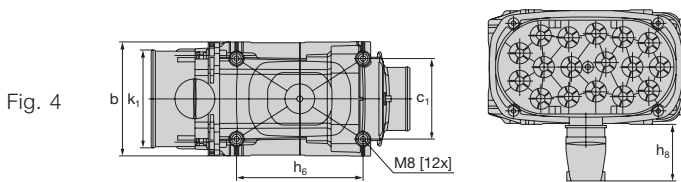
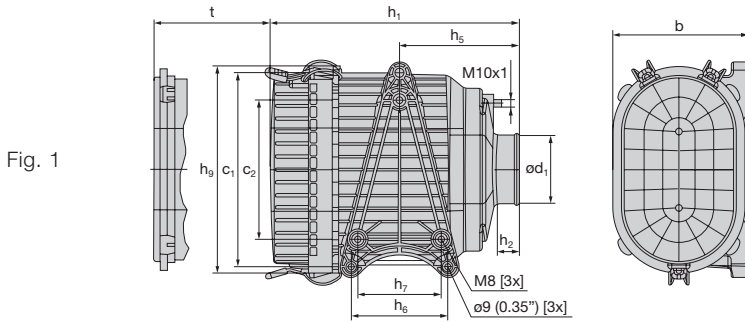

Filter size	Dimensions in mm (Dimensions in inches)								
	b	c ₁	c ₂	c ₇	c ₈	c ₉	d ₁	h ₁	h ₂
IQORON-V 7*	176.4 (6.95)	250 (9.84)	180 (7.09)	–	–	–	89.1 (3.51)	378 (14.88)	30 (1.18)
IQORON-V 9	185 (7.28)	130 (5.12)	–	63 (2.84)	145 (5.71)	100 (3.94)	102 (4.02)	418.8 (16.49)	34 (1.34)

Filter size	Dimensions in mm (Dimensions in inches)								
	h ₅	h ₆	h ₇	h ₈		h ₉	k ₁	k ₂	t
				Fig. 3	Fig. 4				
IQORON-V 7*	155 (6.10)	125 (4.92)	108 (4.25)	86.1 (3.39)	88.5 (3.48)	268.8 (10.58)	153 (6.02)	245.4 (9.66)	50 (1.97)
IQORON-V 9	75.3 (2.97)	205 (8.07)	–	91.1 (3.59)	91.5 (3.60)	314.9 (12.40)	157.2 (6.19)	289.7 (11.41)	210.1 (8.27)

* see Fig. 1,

IQORON-V / IQORON-S

Flow characteristics for flow rates as per ISO 5011

IQORON-V 7

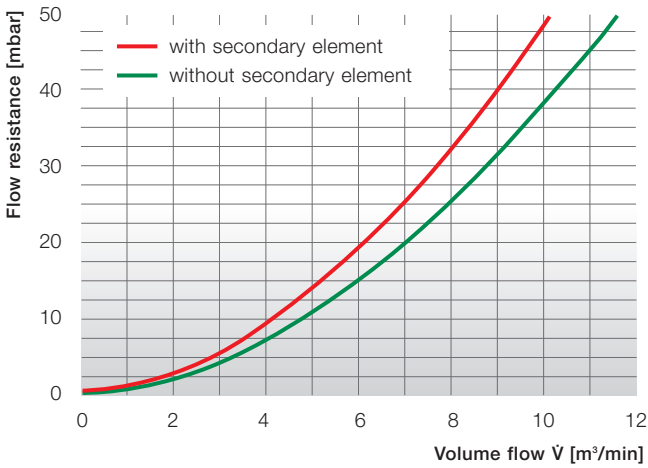

IQORON-V 7

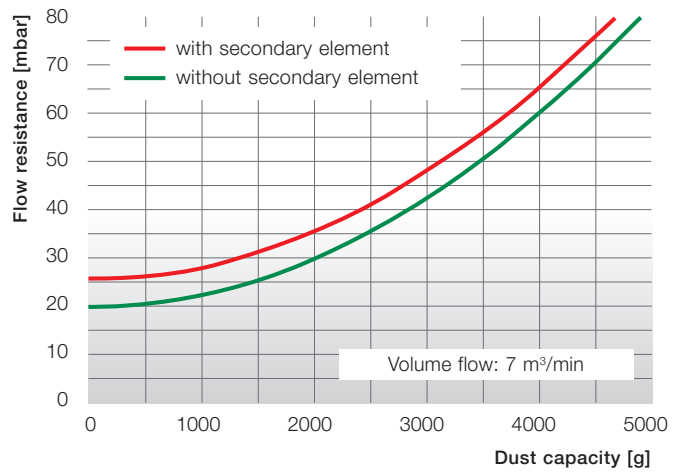

IQORON-S 7

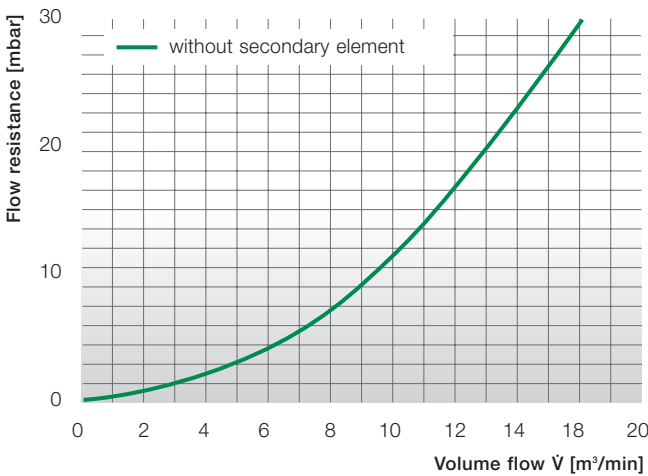

IQORON-S 7

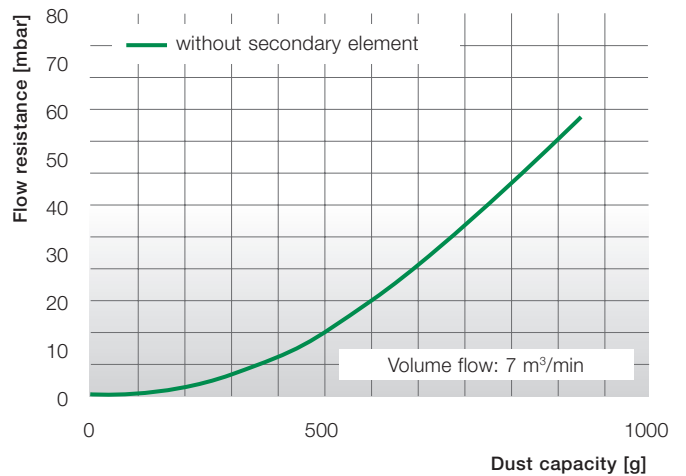

IQORON-V 9

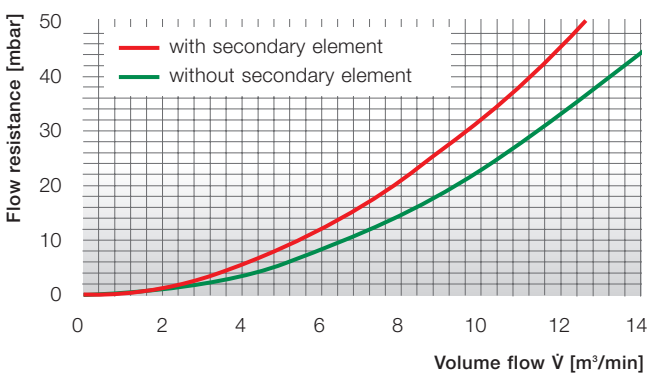

IQORON-V 9

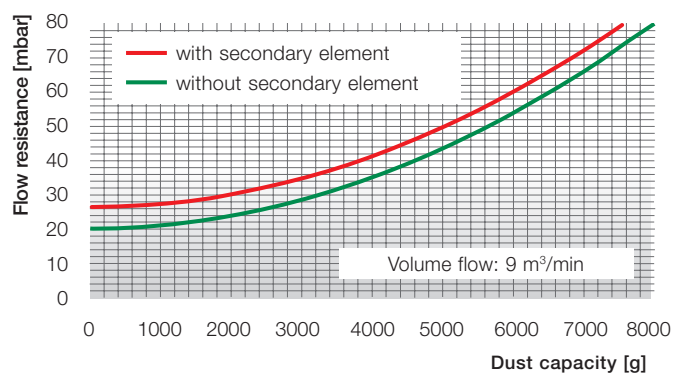



Air cleaners for compressors

ENTARON series



ENTARON XD

Developed for high requirements

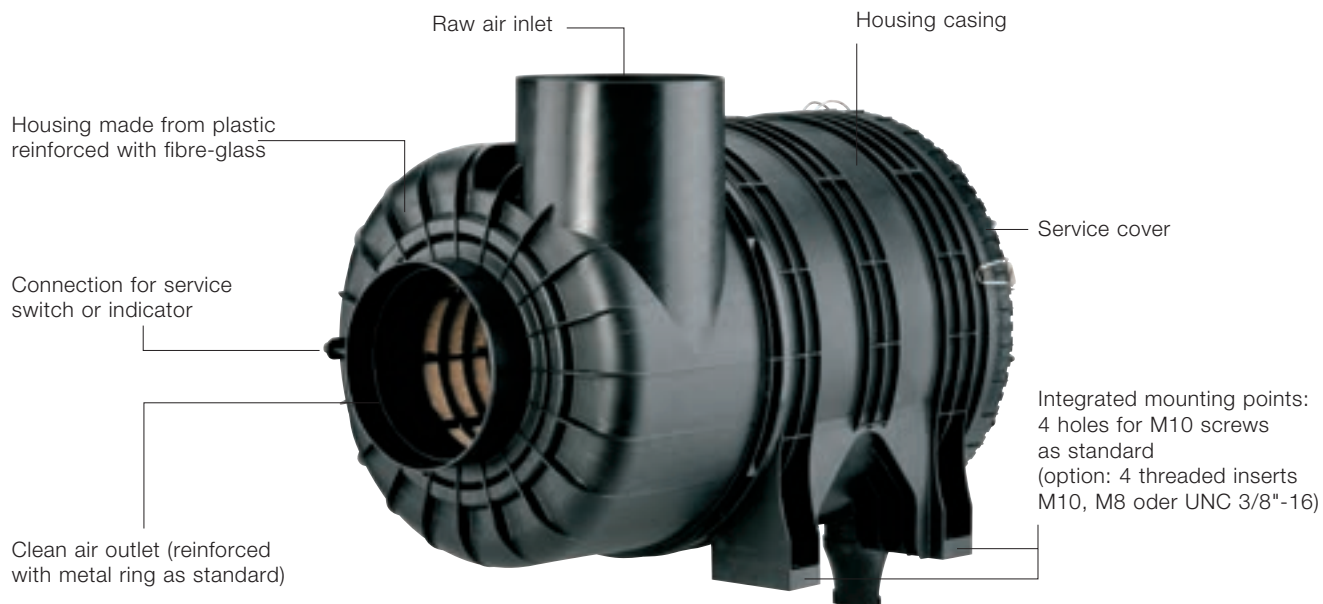

The new ENTARON XD series from MANN+HUMMEL sets new standards for two-stage air cleaners. This series combines the best characteristics of the successful and proven EUROPICLON and NLG air cleaners with a number of innovative new ideas. This makes the ENTARON XD the new benchmark for two-stage tangential air cleaners.

The advantages at a glance:

- Excellent flexibility via variable modular design
- Economic filter system through combination of standard parts
- Corrosion-free and robust housing through use of fibre-glass reinforced plastic
- Easy handling with tool-free filter element replacement
- Total reliability through robust elements and a new sealing system
- Eco-friendly disposal through metal-free filter element (fully incinerable)
- Easy adaptation to different machines through different connection positions
- Quick first installation on vehicle through screw threads integrated in housing (option, on request)
- Suitable for use in extreme conditions

ENTARON XD

High performance filter elements

The filter elements of the new ENTARON XD are thoughtfully designed to handle demanding applications:

- A new sealing system ensures reliable sealing between the elements and housing.
- A robust middle tube made from plastic enforces the filter element and therefore protects the machine and the engine.
- The ENTARON XD uses a filter medium which simultaneously offers dramatically improved separation efficiency and a long service life.
- The MANN+HUMMEL glue string (GST) stabilizes the pleat ends and thus ensures that the element can achieve its full performance under all operating conditions. An advantage only available as standard from MANN+HUMMEL.
- The safety element in the ENTARON XD is screwed to the housing to prevent the possibility of unintentional removal and to ensure reliable function of the filter.

Robust housing

The housing of the new ENTARON XD is reinforced with FEM-designed strengthening ribs and made from plastic reinforced with fibre-glass. This means the filter is able to handle extreme physical conditions and at the same time is resistant to corrosion.

The filter construction consists of three elements with the main housing attached to the connections using a special welding process. This welding ensures a robust and reliable joint and at the same time enables unlimited possible orientations of the connection to the integrated bracket. This achieves an extremely high flexibility and enables adaptation of the filter to almost all installation situations.



The clean air outlet is also reinforced as standard with a metal ring which allows a tightening torque on the hose clamps of up to 5 Nm.

Naturally the standard version also has an integrated connection port for a service switch or indicator.

The high pre-separation efficiency of over 85 % makes the new ENTARON XD ideal for applications with heavy dust loads. This value of 85 % sets the standard for its size filter class with comparable competitor products only able to achieve a much lower value. This high pre-separation efficiency also eliminates the need for an additional external preseparator.

Clever details

Color-coded fasteners simplify handling and are easy to understand even when visibility conditions are unfavorable.

The fasteners can also be locked using special snap-in noses so they are no longer in the way when removing or attaching the cover.

Another user-friendly and clever detail!

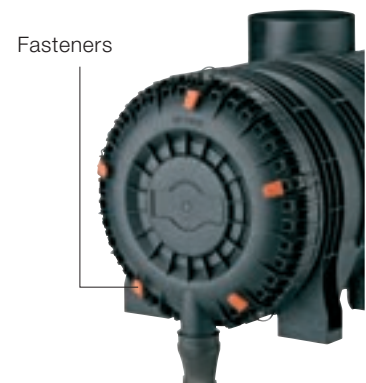

ENTARON XD

Dimensions and part numbers

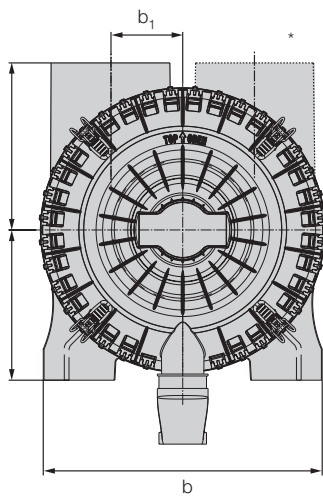

Fig. 1/4

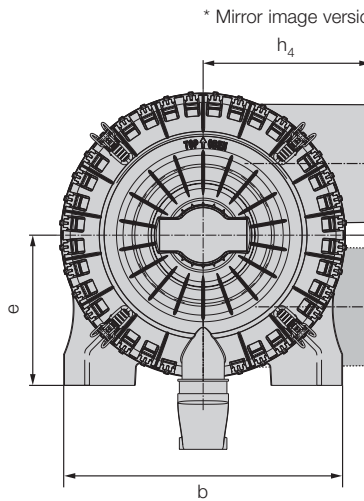

Fig. 2/5

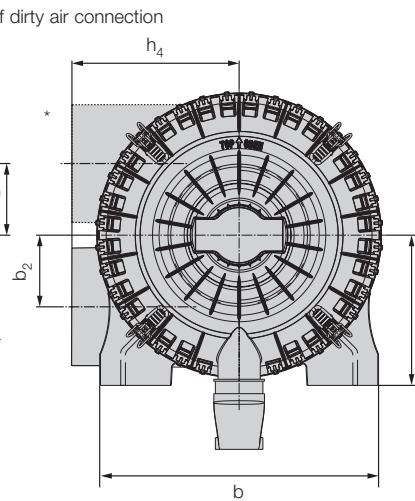

Fig. 3/6

Filter size	Flow rate [m ³ /min]	Position of connecting piece	Fig.	Order no.		Replacement filter element		Weight [kg]
				without secondary element	with secondary element	MANN-FILTER main element	MANN-FILTER secondary element	
ENTARON XD 14	7 - 14	left	1	45 526 92 950	45 526 92 910	C 21 600	CF 1280	5.0
			2	45 526 92 951	45 526 92 911			
			3	45 526 92 952	45 526 92 912			
		right	4	45 527 92 950	45 527 92 910			
			5	45 527 92 951	45 527 92 911			
			6	45 527 92 952	45 527 92 912			
ENTARON XD 17	9 - 17	left	1	45 625 92 950	45 625 92 910	C 23 800	CF 1350	6.3
			2	45 625 92 951	45 625 92 911			
			3	45 625 92 952	45 625 92 912			
		right	4	45 626 92 950	45 626 92 910			
			5	45 626 92 951	45 626 92 911			
			6	45 626 92 952	45 626 92 912			
ENTARON XD 21*	11 - 21	left	1	45 722 92 950	45 722 92 910	C 25 900	CF 1470	7.3
			2	45 722 92 951	45 722 92 911			
			3	45 722 92 952	45 722 92 912			
		right	4	45 723 92 950	45 723 92 910			
			5	45 723 92 951	45 723 92 911			
			6	45 723 92 952	45 723 92 912			
ENTARON XD 21-24*	11 - 21	left	1	45 722 92 980	45 722 92 960	C 25 1020	CF 1480	7.9
			2	45 722 92 981	45 722 92 961			
			3	45 722 92 982	45 722 92 962			
		right	4	45 723 92 980	45 723 92 960			
			5	45 723 92 981	45 723 92 961			
			6	45 723 92 982	45 723 92 962			
ENTARON XD 28*	14 - 28	left	1	45 920 92 950	45 920 92 910	C 28 1300	CF 1750	9.6
			2	45 920 92 951	45 920 92 911			
			3	45 920 92 952	45 920 92 912			
		right	4	45 921 92 950	45 921 92 910			
			5	45 921 92 951	45 921 92 911			
			6	45 921 92 952	45 921 92 912			
ENTARON XD 28-32*	14 - 28	left	1	45 920 92 980	45 920 92 960	C 28 1460	CF 1760	10.1
			2	45 920 92 981	45 920 92 961			
			3	45 920 92 982	45 920 92 962			
		right	4	45 921 92 980	45 921 92 960			
			5	45 921 92 981	45 921 92 961			
			6	45 921 92 982	45 921 92 962			

* Successor generation to EUROPICLON 700 and EUROPICLON 800

ENTARON XD

Dimensions and part numbers

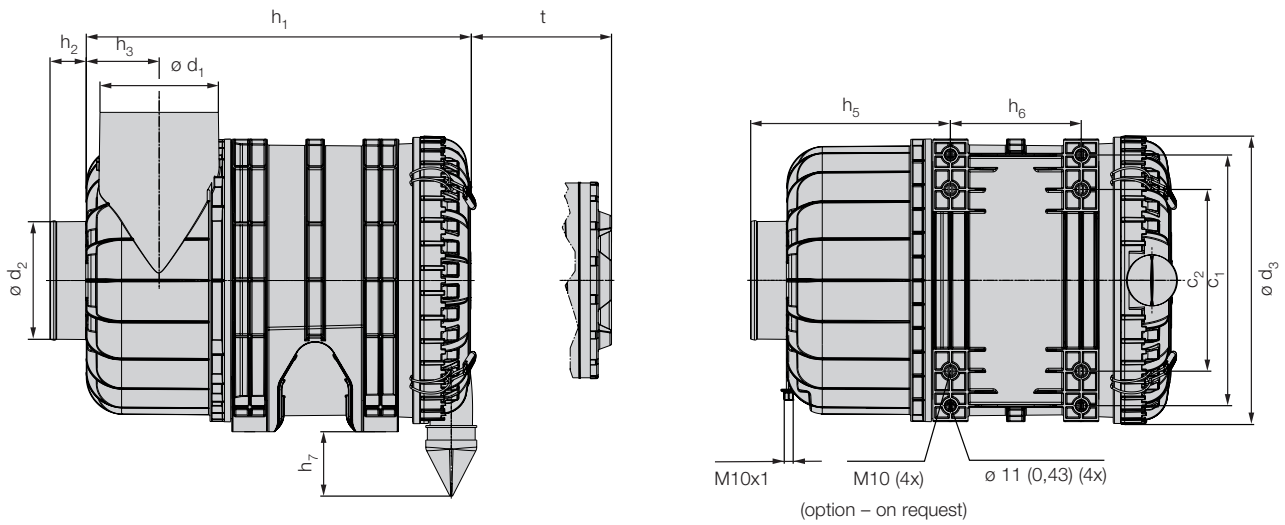

Dimensions in mm (*Dimensions in inches*)

Filter size	b	b ₁	c ₁	c ₂	d ₁	d ₂	d ₃	e	h ₁	h ₂	h ₃	h ₄	h ₅	h ₆	h ₇	t
ENTARON XD 14	300 (11.82)	79 (3.11)	263.3 (10.37)	175.3 (6.90)	130 (5.20)	110 (4.33)	305.7 (12.04)	159.7 (6.29)	422.9 (16.65)	45 (1.77)	72.8 (2.87)	186.5 (7.34)	218.4 (8.60)	136.8 (5.39)	85.8 (3.38)	362 (14.25)
ENTARON XD 17	328.2 (12.92)	90.1 (3.55)	291.8 (11.92)	203.8 (8.03)	130 (5.20)	130 (5.20)	335.1 (13.19)	173.7 (6.84)	474.8 (18.70)	45 (1.77)	80.3 (3.16)	198 (7.80)	235.8 (9.29)	169.9 (6.69)	90.4 (3.56)	408 (16.06)
ENTARON XD 21	357.8 (14.09)	92 (3.62)	320 (12.60)	232 (9.13)	150 (5.91)	150 (5.91)	368.9 (14.52)	193 (7.60)	491 (19.33)	45 (1.77)	90 (3.54)	215 (8.46)	254 (10)	167 (6.58)	82.1 (3.23)	426 (16.77)
ENTARON XD 21-24	357.8 (14.09)	92 (3.62)	320 (12.60)	232 (9.13)	150 (5.91)	150 (5.91)	368.9 (14.52)	193 (7.60)	546 (21.50)	45 (1.77)	90 (3.54)	215 (8.46)	254 (10)	221.8 (8.73)	82.1 (3.23)	480 (18.90)
ENTARON XD 28	388 (12.28)	96 (3.78)	354 (13.94)	266 (10.47)	180 (7.09)	180 (7.09)	398 (15.63)	208 (8.19)	572 (22.48)	45 (1.77)	105 (4.13)	245 (9.65)	283 (11.14)	220 (8.66)	80.7 (3.18)	505 (19.88)
ENTARON XD 28-32	388 (12.28)	96 (3.78)	354 (13.54)	266 (10.47)	180 (7.09)	180 (7.09)	398 (15.63)	208 (8.19)	638 (25.12)	45 (1.77)	105 (4.13)	245 (9.65)	283 (11.14)	285 (11.22)	80.7 (3.18)	573 (22.56)

ENTARON XD

Flow characteristics

Flow characteristics for flow rates according ISO 5011
ENTARON XD 14

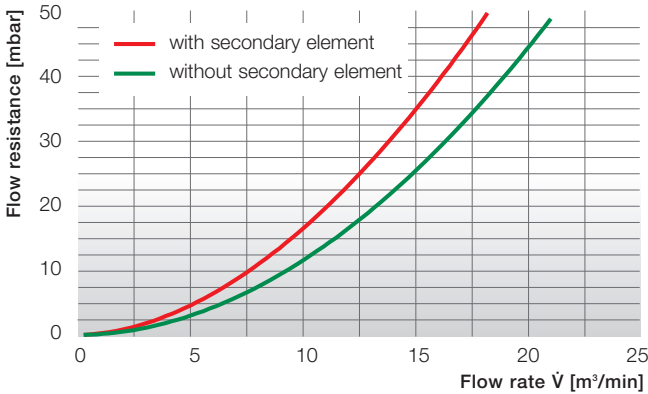

Flow characteristics for dust capacity according ISO 5011
ENTARON XD 14

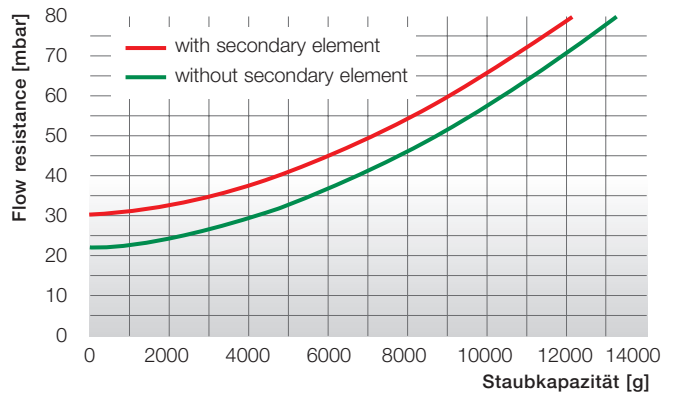

Flow characteristics for flow rates according ISO 5011
ENTARON XD 17

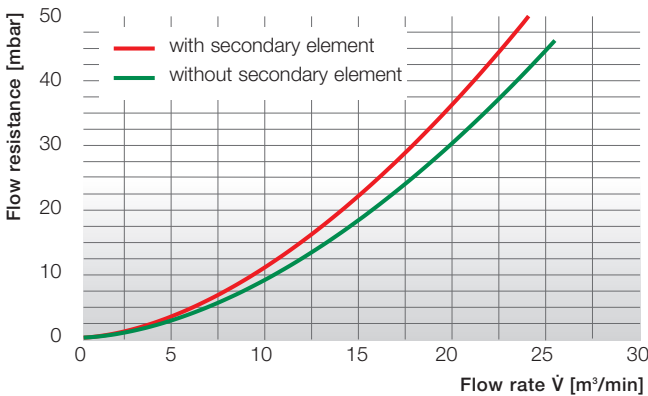

Flow characteristics for dust capacity according ISO 5011
ENTARON XD 17

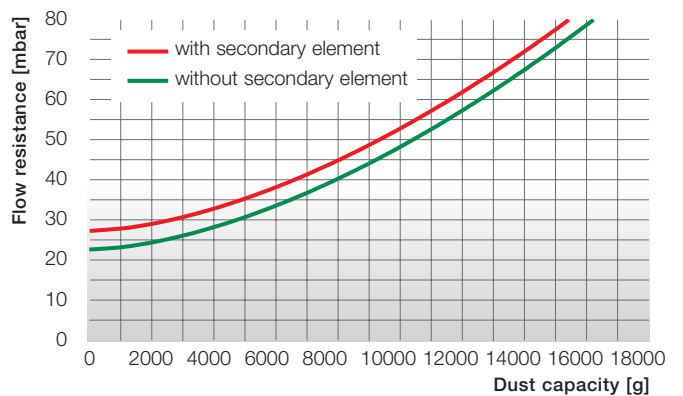

Flow characteristics for flow rates according ISO 5011
ENTARON XD 21

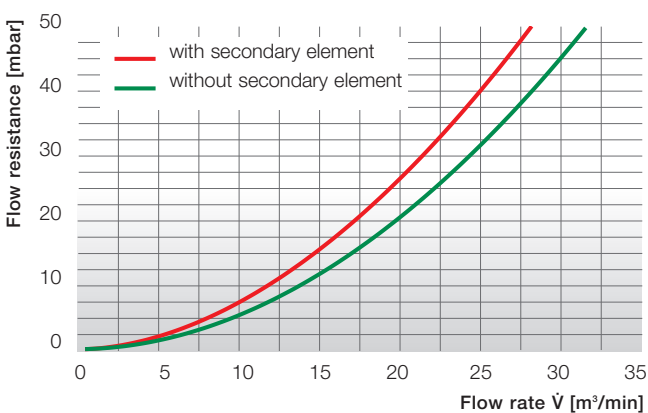

Flow characteristics for dust capacity according ISO 5011
ENTARON XD 21

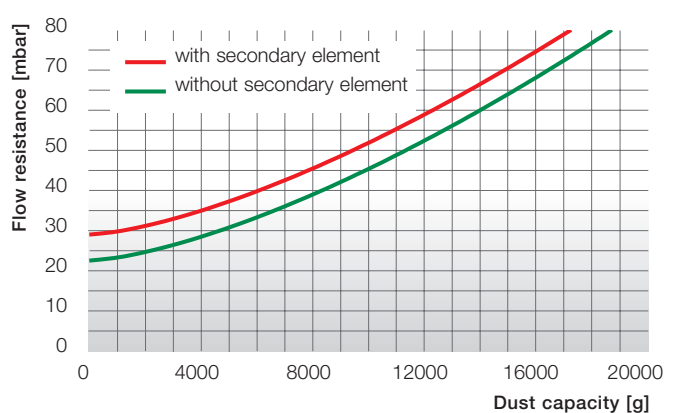

Further specifications:

Operating temperatures: -30 °C to +90 °C
 Continuous operation: +110 °C short-term

Tightening torque: 15 Nm threaded insert
 Mounting screws: 23 Nm through-hole

ENTARON XD

Flow characteristics

Flow characteristics for flow rates according ISO 5011
ENTARON XD 21-24

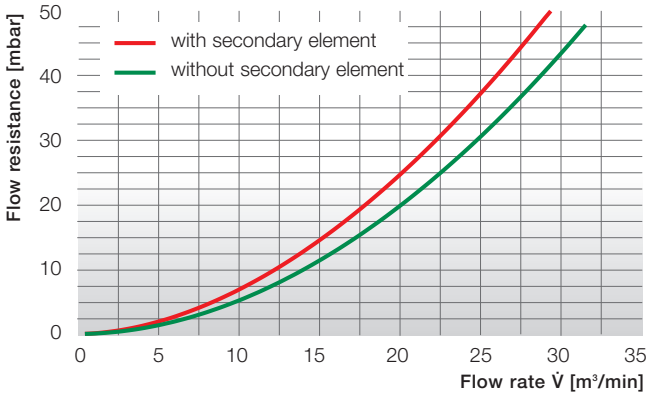

Flow characteristics for dust capacity according ISO 5011
ENTARON XD 21-24

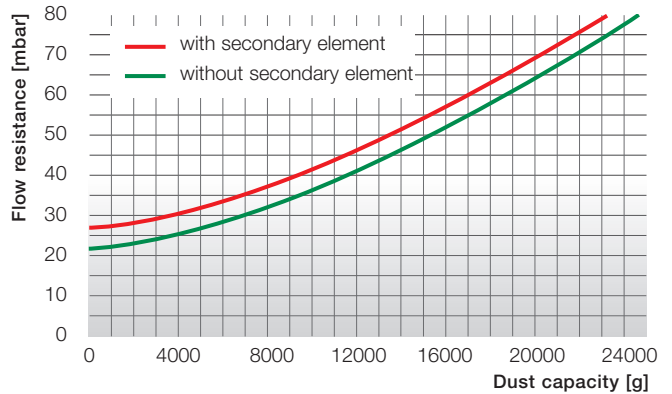

Flow characteristics for flow rates according ISO 5011
ENTARON XD 28

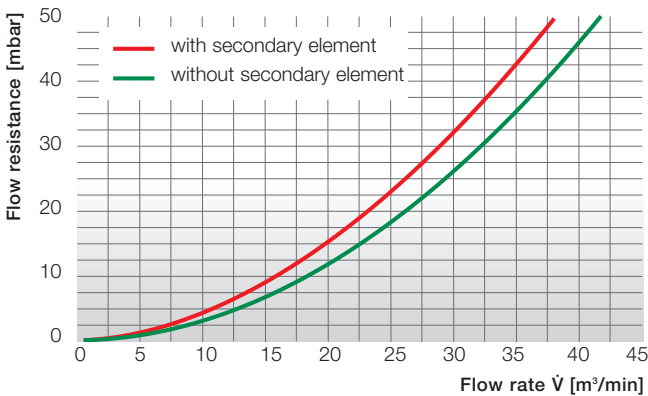

Flow characteristics for dust capacity according ISO 5011
ENTARON XD 28

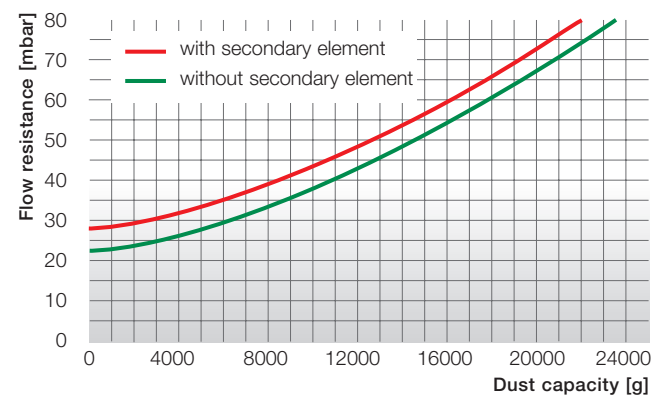

Flow characteristics for flow rates according ISO 5011
ENTARON XD 28-32

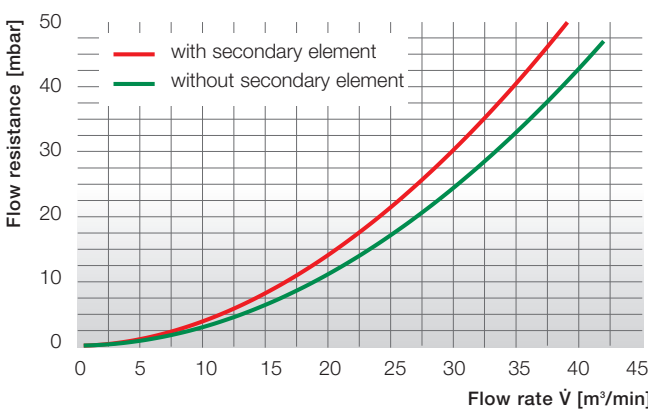

Flow characteristics for dust capacity according ISO 5011
ENTARON XD 28-32

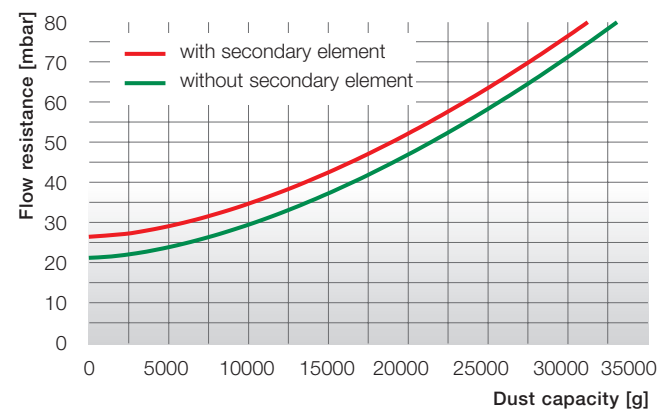

Further specifications:

Tightening torque for hose clamp (on clean side): max. 5 Nm

Housing material:
Connection dimension of dust discharge:

PP GF 30 / Cr(VI)-free
Diameter 54 mm

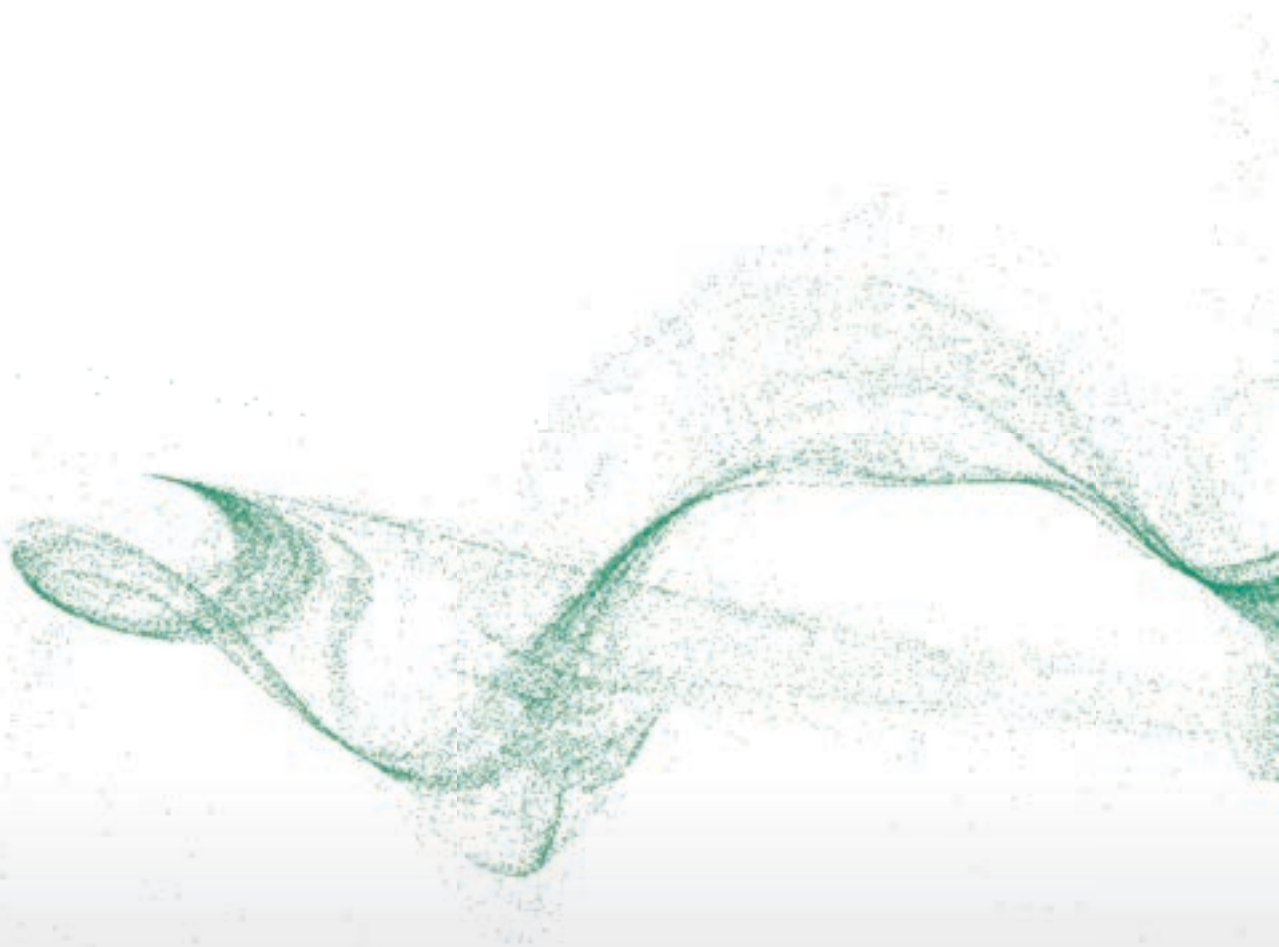

Air cleaners for compressors EUROPICLON



EUROPICLON

The flexible allrounder



The EUROPICLON from MANN+HUMMEL is characterised by its high dust capacity and low pressure drop.

These characteristics have made the EUROPICLON the tried and tested air cleaner for all machines and equipment used in conditions with medium to heavy dust loads. These include construction and agricultural machines, mobile compressors and harvesting machines.

Advantages at a glance:

- Long service life through integrated pre-separation
- Highly economical through modular system
- Extensive range of accessories
- Corrosion free housing in impact resistant plastic
- Easy element change without tools
- Highest operational reliability through elements with proven radial seal
- Metal-free filter elements are easily disposed of by incineration and therefore are environmentally friendly with inexpensive disposal
- Easy adaptation to other equipment with a flexible bracket system
- Patented filter elements

EUROPICLON

Sectional view

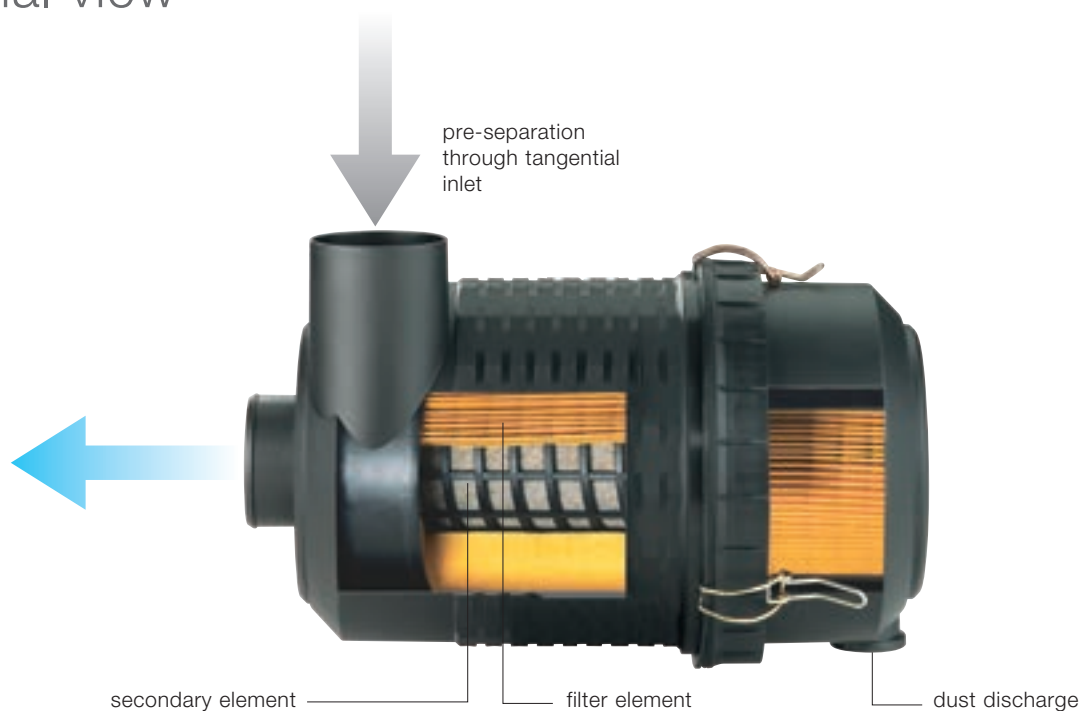

Housing

The housing of the EUROPICLON is made of impact resistant polypropylene and is suitable for continuous use in the temperature range -40 °C to +80 °C or for short periods up to +100 °C.

The external polygon design of the housing is recognisable in the picture. The EUROPICLON bracket, designed especially for this structure, can be turned in increments of 5° opposite to the housing.

Depending on the air cleaner size, the housing can be turned in the axial direction to six different locking positions. This offers the designer up to 432 different fitting possibilities for the air cleaner. In addition, the wire clamps which lock the air cleaner housing can be placed in special pockets on the cap to adapt to special installation conditions.

Filter elements

The EUROPICLON elements are free of metal and therefore easily disposed of by incineration. This enables inexpensive and environmentally friendly disposal of the used elements.

EUROPICLON Main element:

- High dust capacity through special MANN+HUMMEL filter medium
- High reliability through radial seal on housing
- Reliable pleat stability prevents pleats sticking together under demanding conditions



EUROPICLON Secondary element:

- MANN+HUMMEL synthetic fabric allows a high safety margin with low pressure drop
- Secure fit in housing prevents unintentional removal of the secondary element



EUROPICLON 100 to 800

Dimensions and part numbers

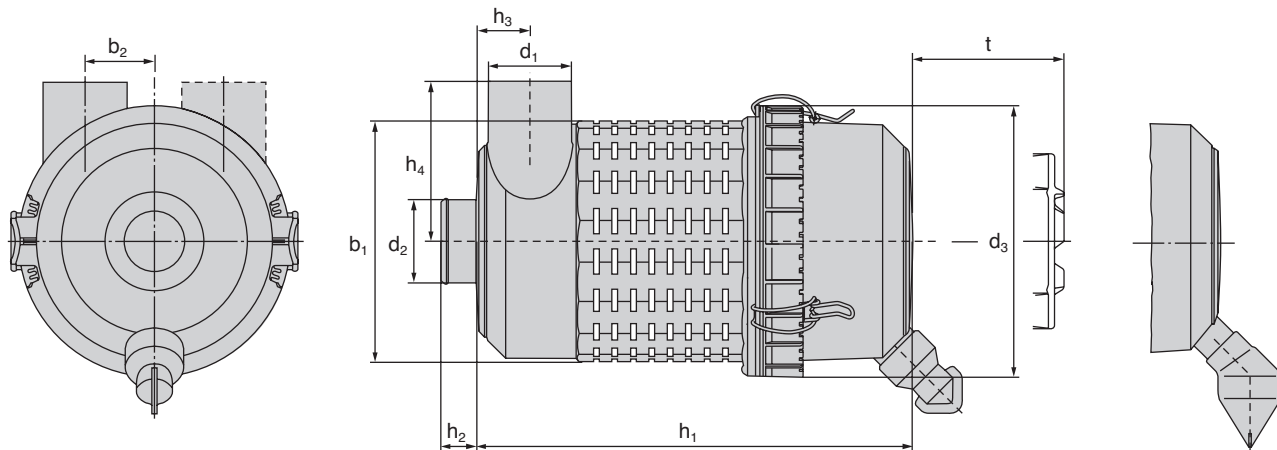

Fig. 1
Mirror image version of the dirty air connection available on request

1a

1b

Size EUROPICLON	Order no.		Fig.	Nominal flow rate [m³/min]	Replace filter element		Weight [kg]
	without secondary element	with secondary element			MANN-FILTER main element	MANN-FILTER secondary element	
100	45 100 92 910	45 100 92 911	1a	1 - 3	C 11 100	CF 100	0.9
	45 100 92 940	45 100 92 941	1b				
200	45 200 92 910	45 200 92 911	2a	2 - 4.5	C 14 200	CF 200	1.7
	45 200 92 920	45 200 92 921	2b				
	45 200 92 940	45 200 92 941	2c				
300	45 300 92 910	45 300 92 911	2a	3 - 6	C 15 300	CF 300	2.1
	45 300 92 920	45 300 92 921	2b				
	45 300 92 940	45 300 92 941	2c				
400	45 400 92 910	45 400 92 911	2a	4 - 8	C 16 400	CF 400	3.0
	45 400 92 920	45 400 92 921	2b				
	45 400 92 940	45 400 92 941	2c				
500	45 500 92 910	45 500 92 911	2a	6 - 12	C 20 500	CF 500	3.8
	45 500 92 920	45 500 92 921	2b				
	45 500 92 940	45 500 92 941	2c				
600	45 600 92 910	45 600 92 911	2a	7.5 - 15	C 23 610	CF 610	5.0
	45 600 92 920	45 600 92 921	2b				
	45 600 92 940	45 600 92 941	2c				
700	45 700 92 940	45 700 92 941	2c	15 - 21	C 25 710/3 *	CF 710	6.0
800	45 800 92 940	45 800 92 941	2c	18 - 28	C 30 810/3	CF 810	9.0

* with glue strip

EUROPICLON 100 to 800

Dimensions and part numbers

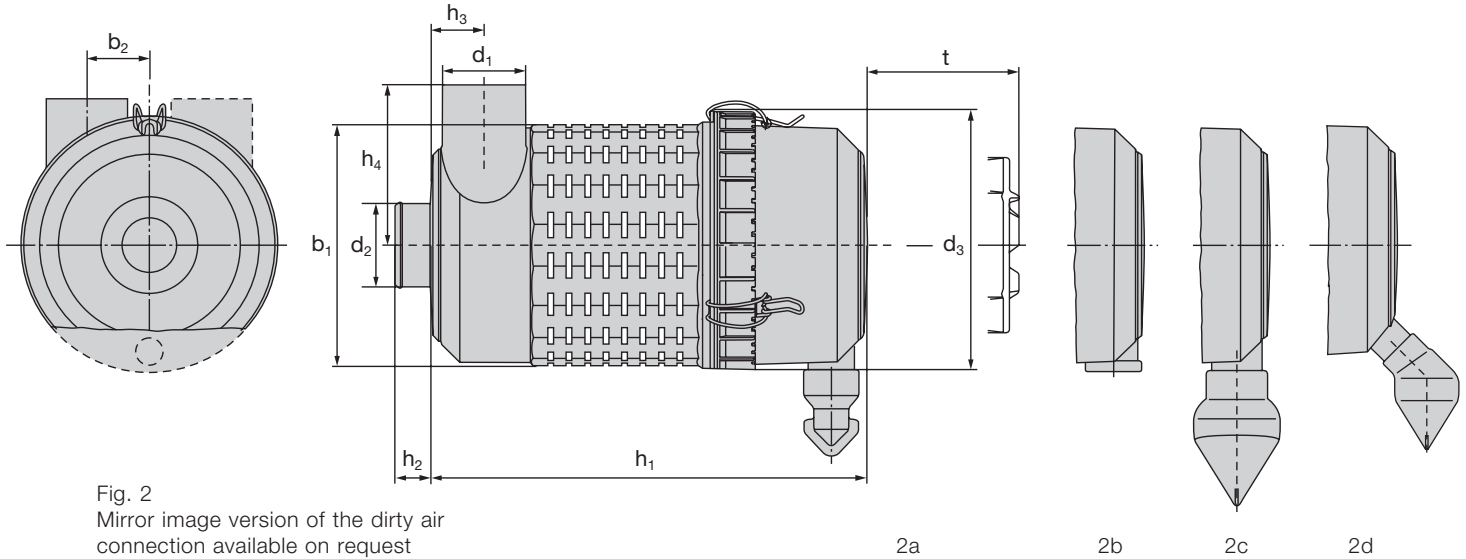

Fig. 2
Mirror image version of the dirty air connection available on request

Order no.		Fig.	Dimensions in mm (<i>Dimensions in inches</i>)									
without secondary element	with secondary element		b ₁	b ₂	d ₁	d ₂	d ₃	h ₁	h ₂	h ₃	h ₄	t
45 100 92 910	45 100 92 911	1a	158	45	54	50	188	260	27	38	104	237
45 100 92 940	45 100 92 941	1b	(6.22)	(1.77)	(2.12)	(1.97)	(7.40)	(10.24)	(1.06)	(1.50)	(4.09)	(9.39)
45 200 92 910	45 200 92 911	2a	173	48	62	60	198	327	27	42	112	304
45 200 92 920	45 200 92 921	2b										
45 200 92 940	45 200 92 941	2c										
45 300 92 910	45 300 92 911	2a	203	59	70	70	228	367	30	45	135	344
45 300 92 920	45 300 92 921	2b										
45 300 92 940	45 300 92 941	2c										
45 400 92 910	45 400 92 911	2a	223	63	82	80	248	383	32	52	144	359
45 400 92 920	45 400 92 921	2b										
45 400 92 940	45 400 92 941	2c										
45 500 92 910	45 500 92 911	2a	264	73	102	100	288	408	37	62	174	384
45 500 92 920	45 500 92 921	2b										
45 500 92 940	45 500 92 941	2c										
45 600 92 910	45 600 92 911	2a	295	87	110	110	323	414	27	65	190	384
45 600 92 920	45 600 92 921	2b										
45 600 92 940	45 600 92 941	2c										
45 700 92 940	45 700 92 941	2d	325	92	132	130	353	548	32	76	212	500
			(12.80)	(3.62)	(5.20)	(5.12)	(13.90)	(21.57)	(1.26)	(2.99)	(8.35)	(19.69)
45 800 92 940	45 800 92 941	2d	390	114	150	150	418	598	32	85	241	550
			(15.35)	(4.49)	(5.91)	(5.91)	(16.46)	(23.54)	(1.26)	(3.35)	(9.49)	(21.65)

EUROPICLON 100 to 800

Flow characteristics for flow rates as per ISO 5011

Without secondary element

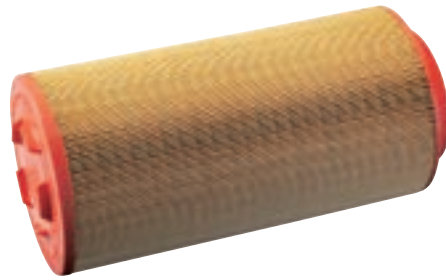
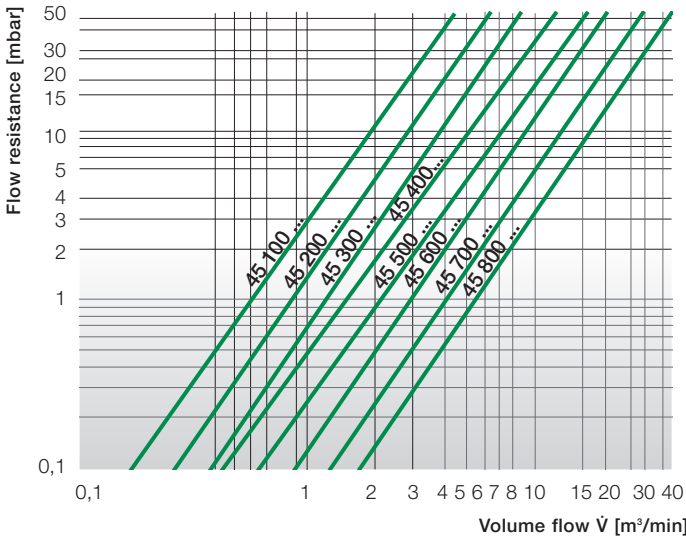

With secondary element

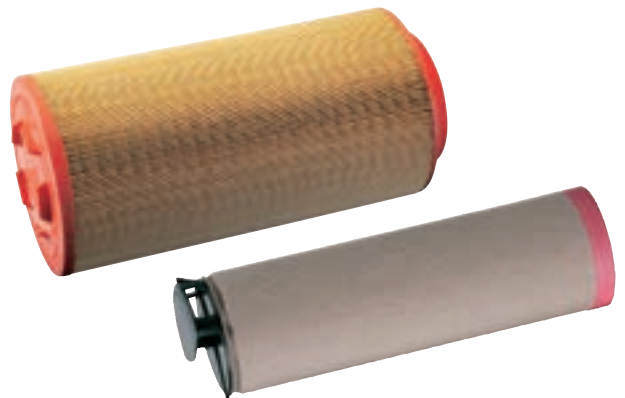
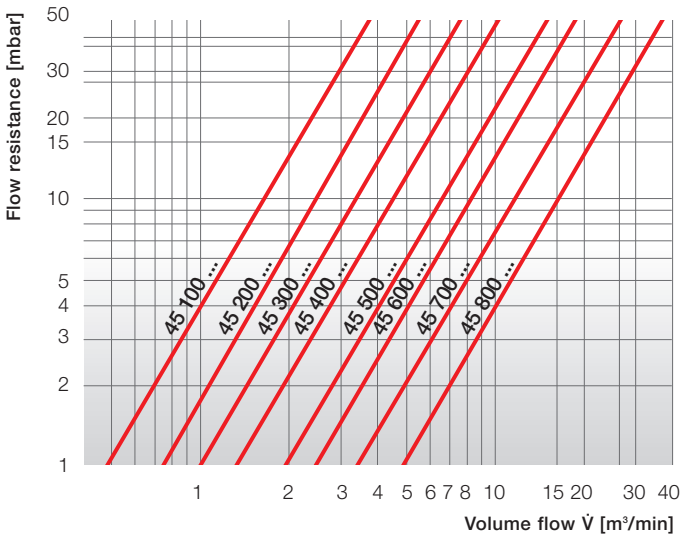

EUROPICLON 100 to 800

Flow characteristics for dust capacity
as per ISO 5011 with SAE coarse test dust

45 100 92 9x1 – 3.0 m³/min.

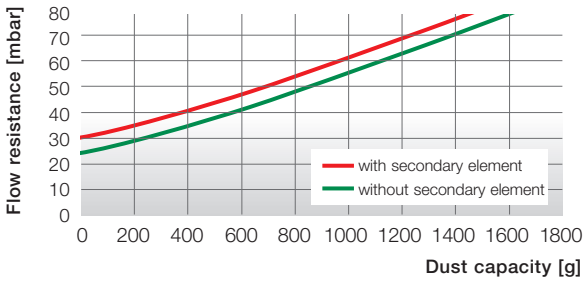

45 200 92 9x1 – 4.5 m³/min.

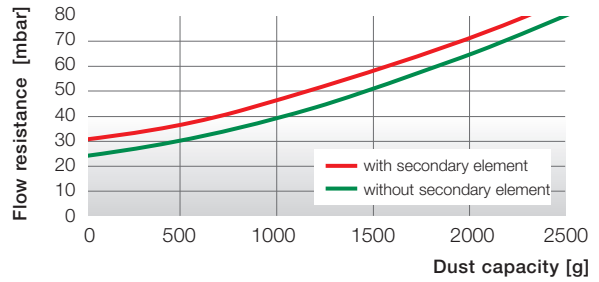

45 300 92 9x1 – 6.0 m³/min.

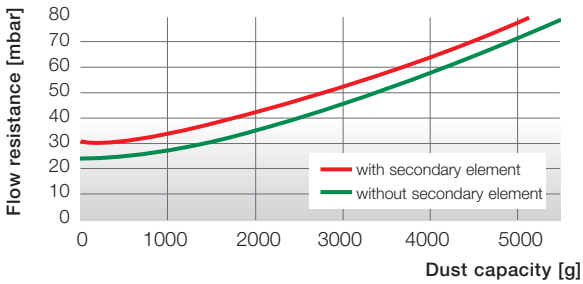

45 400 92 9x1 – 8.0 m³/min.

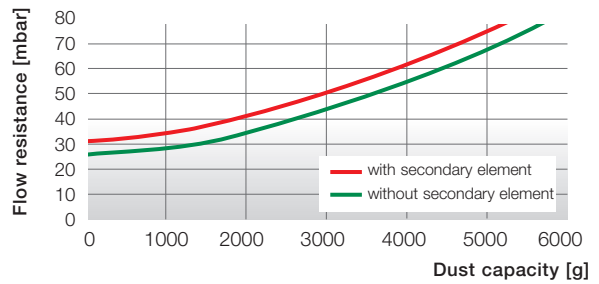

45 500 92 9x1 – 12.0 m³/min.

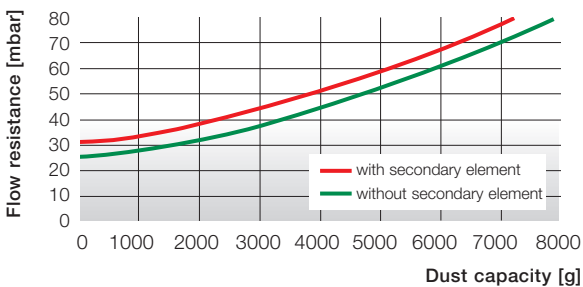

45 600 92 9x1 – 15.0 m³/min.

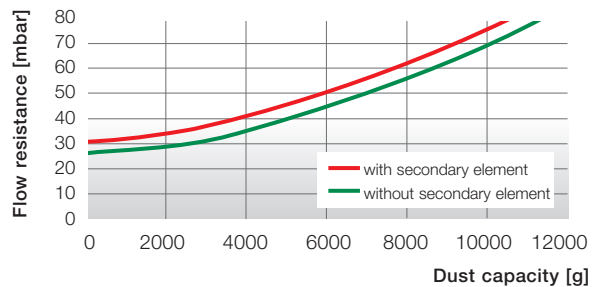

45 700 92 9x1 – 21.0 m³/min.

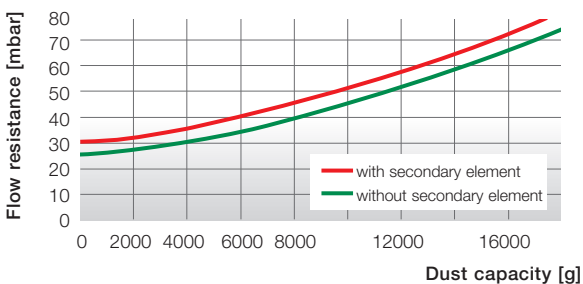

45 800 92 9x1 – 28.0 m³/min.

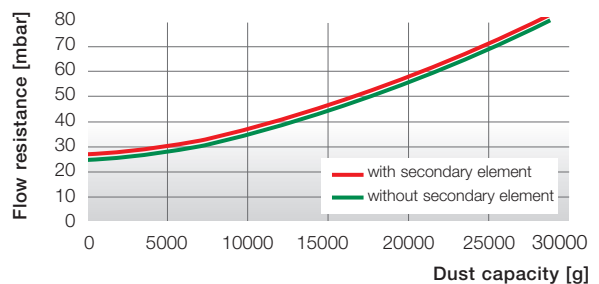

EUROPICLON 50



The new Europiclone 50 from MANN+HUMMEL extends the range of the successful EUROPICLON line to engines and equipment with a power rating up to 20 kW.

Along with the known advantages of the EUROPICLON line which include reliability, long service life and its robust, corrosion-free housing, the new EUROPICLON 50 has a number of additional features which offer important advantages for the designer and user.

Advantages at a glance:

- Twelve-position clean air outlet with integrated connection for service indicator or switch
- Clean air outlet available with straight pipe connection or with a 90° elbow
- Space-saving wire clamp fasteners and easy filter element change without tools
- Especially low pressure drop also in operation with fitted secondary element
- Cost-effective

Bracket

The EUROPICLON 50 bracket offers flexibility during installation with 16 different available positions around its circumference and two possible locking positions in the axial direction.

The special polygon design is matched to the air cleaner housing and ensures that the air cleaner fits securely in the bracket.



EUROPICLON 50

Filter elements

The new filter elements for the EUROPICLON 50 offer high performance and are cost-effective. The radial seal used for the main element in connection with the special pleat stabilisation enables a high separation efficiency of more than 99.95 % and a high dust capacity. A further advantage is the patented MANN+HUMMEL production technology where the seal and the element end plates are manufactured in one process step using special elastomers.

A plastic centre tube in the housing provides good support for the element without negatively influencing the withdrawal distance.

A secondary element protects the engine during a filter service or if the main element is damaged. It is an important component for comprehensive engine protection, which ensures the maximum service life

of your machine. The secondary element of the new EUROPICLON 50 consists of a special synthetic fabric, a plastic centre tube and a radial seal in PUR foam. The filter surface area is approx. 45 % larger than comparable products from the competition. This leads to minimal pressure drop with an increase in the service life of the filter.

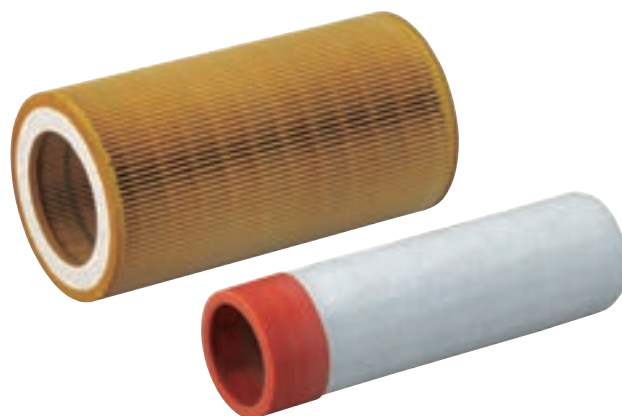

Clean air outlet

On the clean air side the new EUROPICLON 50 is equipped with a twelve-position clean air outlet. This port is available in a straight pipe version or with a 90° elbow.

As the hanging installation position is not recommended for the service switch, MANN+HUMMEL offers the 90° elbow in two versions.

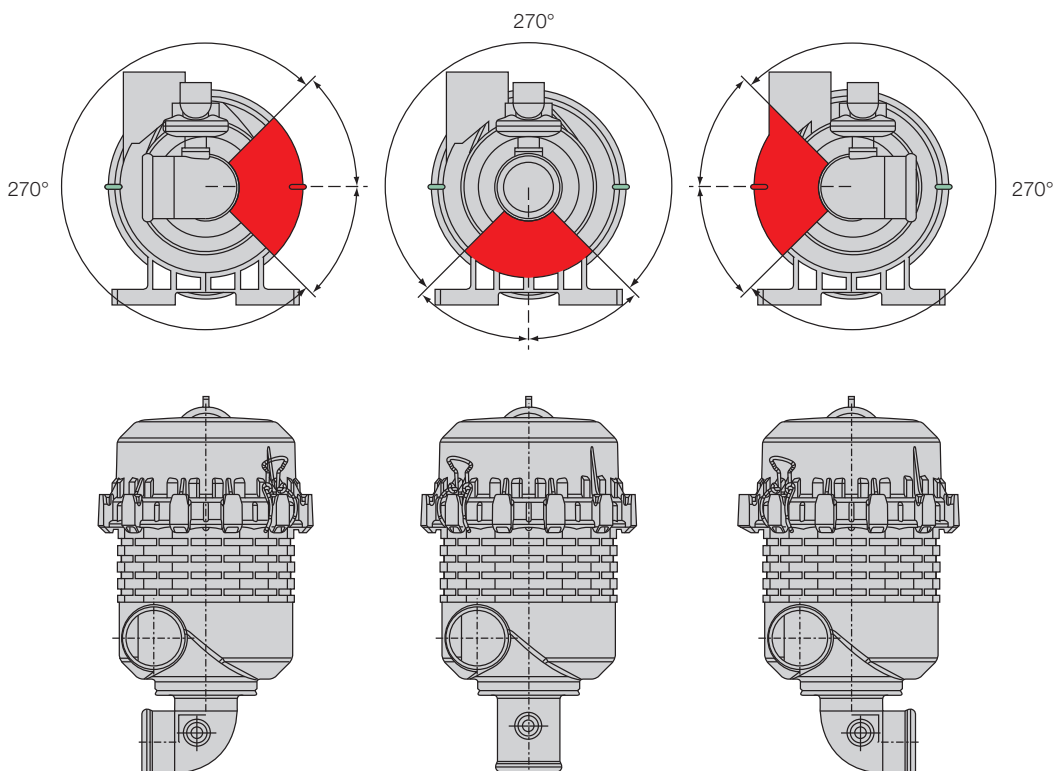

Note: The red areas are not recommended for fitting.

EUROPICLON 50

Dimensions and part numbers

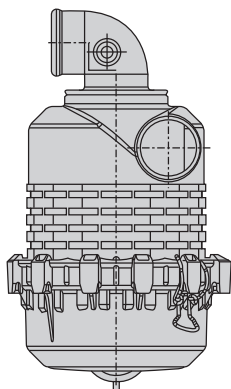

90° elbow
Fig. 1

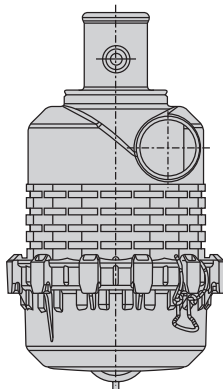

Straight pipe
Fig. 2

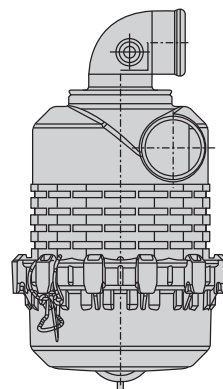

90° elbow
Fig. 3

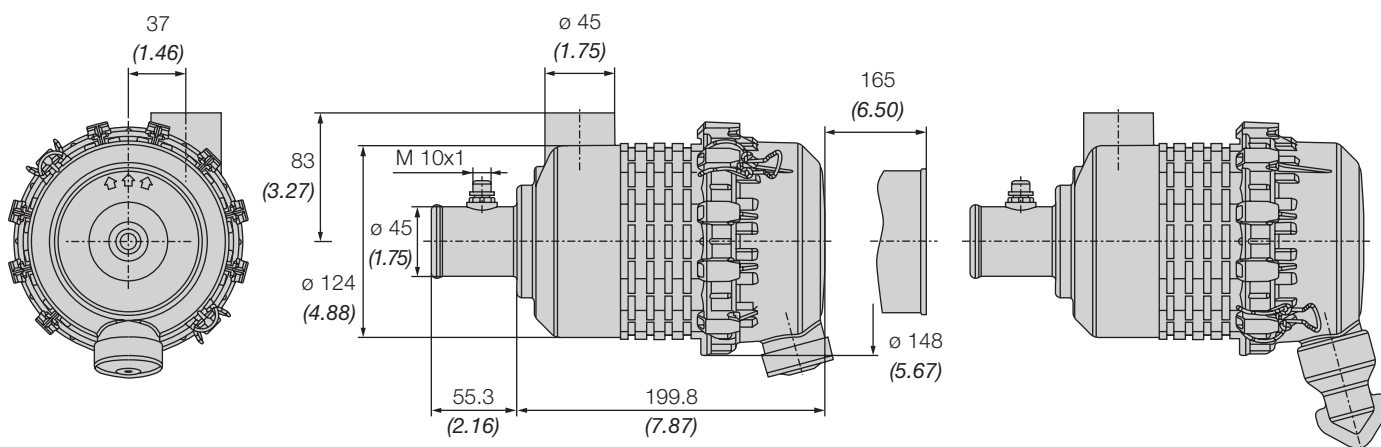

Fig. 4

Fig. 5

Order no.*		Version Clean air outlet Fig.	Version Dust discharge Fig.	Nominal flow rate [m ³ /min]	Replacement filter element		Weight [kg]
without secondary element	with secondary element				MANN-FILTER main element	MANN-FILTER secondary element	
45 058 92 910	45 058 92 911	1	5	0.8 – 2	C 10 050	CF 50	0.7
45 058 92 920	45 058 92 921	1	4				
45 050 92 910	45 050 92 911	2	5	0.8 – 2	C 10 050	CF 50	0.7
45 050 92 920	45 050 92 921	2	4				
45 059 92 910	45 059 92 911	3	5	0.8 – 2	C 10 050	CF 50	0.7
45 059 92 920	45 059 92 921	3	4				

* These part numbers are currently not available in Canada, the U.S. and Mexico.

If you are interested in these products, please contact your local MANN+HUMMEL partner for suitable alternatives

EUROPICLON 50

Flow characteristics

Flow characteristics for flow rates as per ISO 5011 with straight pipe

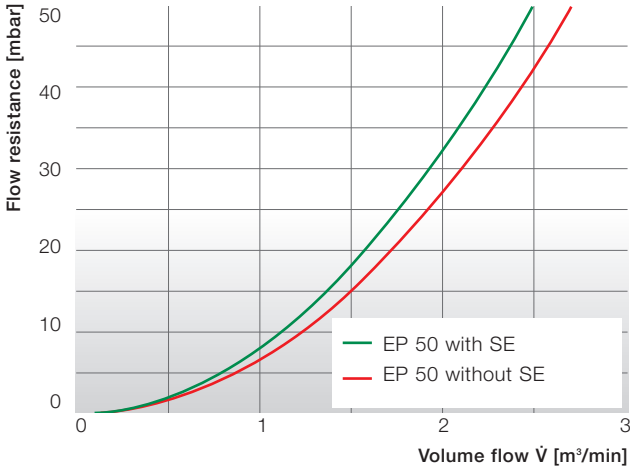

Flow characteristics for flow rates as per ISO 5011 with 90° elbow

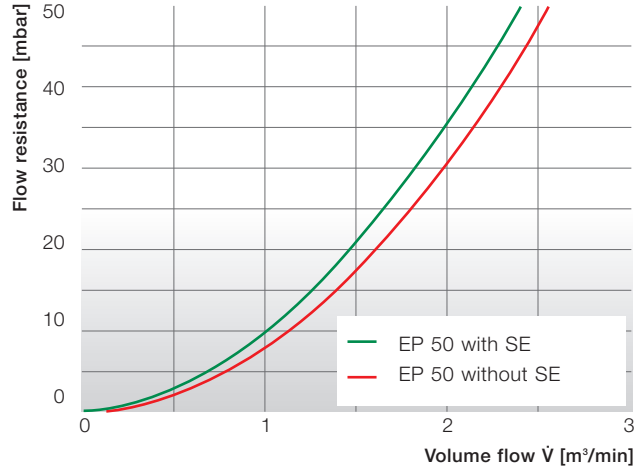

Flow characteristics for dust capacity as per ISO 5011 with straight pipe with secondary element

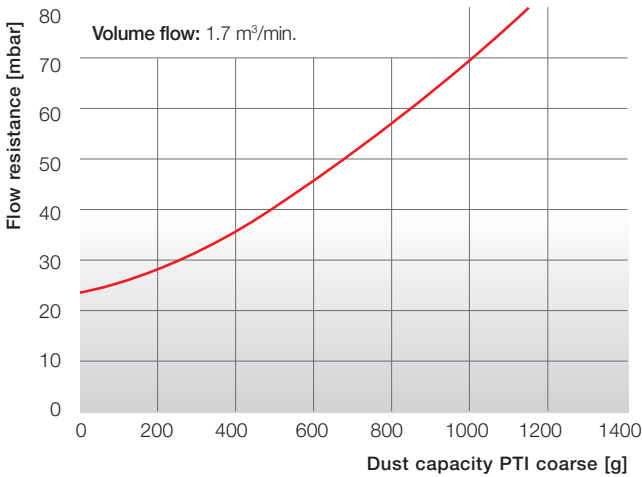

Flow characteristics for dust capacity as per ISO 5011 with 90° elbow with secondary element

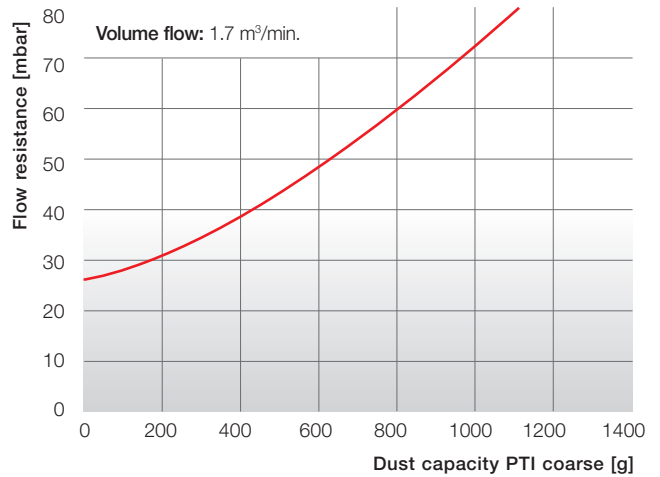

Flow characteristics for dust capacity as per ISO 5011 with straight pipe without secondary element

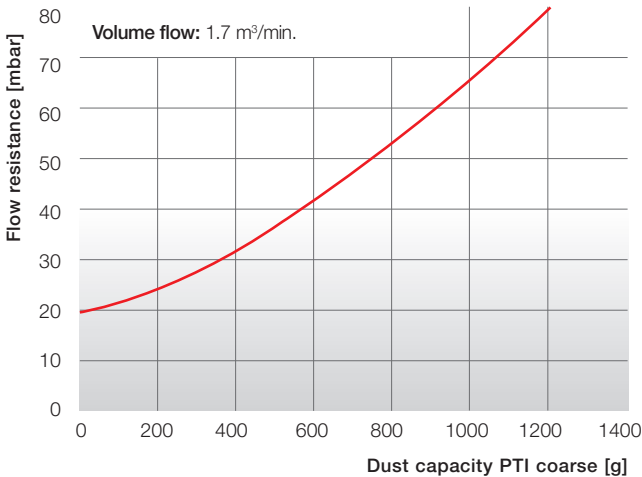

Flow characteristics for dust capacity as per ISO 5011 with 90° elbow without secondary element

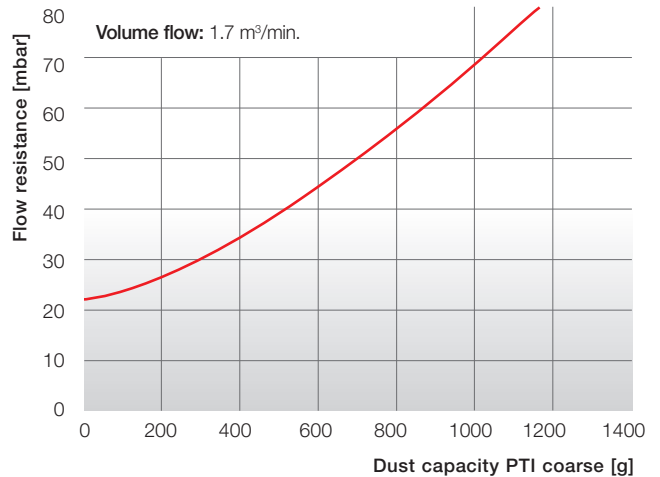

EUROPICLON

Accessories



Filter size EUROPICLON	Rain cap	Straight pipe		90° elbow	
	design A * (p. 100)	without connection (p. 103)	with connection (p. 103)	without connection (p. 102)	with connection (p. 102)
50	39 014 67 910	–	–	–	–
100	39 020 67 910	39 100 27 999	39 100 27 979	39 100 25 999	39 100 25 979
200	39 028 67 910	39 200 27 999	39 200 27 979	39 200 25 999	39 200 25 979
300	39 040 67 910	39 300 27 999	39 300 27 979	39 300 25 999	39 300 25 979
400	39 056 67 910	39 400 27 999	39 400 27 979	39 400 25 999	39 400 25 979
500	39 080 67 910	39 500 27 999	39 500 27 979	39 500 25 999	39 500 25 979
600	39 100 67 910	39 600 27 999	39 600 27 979	39 600 25 999	39 600 25 979
700	39 160 67 910	39 700 27 999	39 700 27 979	39 700 25 999	39 700 25 979
800	39 190 67 910	39 800 27 999	39 800 27 979	39 800 25 999	39 800 25 979

* Alternative design B possible (see page 101)

Dust discharge valves

Order no.	Name	Suitable for
23 040 30 111	Diaphragm valve	45 x00 92 920/921
39 000 40 391	Small dust discharge valve	45 x00 92 910/911
39 000 40 661	Large dust discharge valve	44 x00 92 940/941
39 000 40 102	Large dust discharge valve	45 x00 92 940/941

You will find the complete range of accessories for our air cleaners on page 99.

x = 1 to 8

EUROPICLON Brackets

The brackets are especially designed for the external surface of the EUROPICLON housing and allow vibration-free mounting of the air cleaner.

From size 700 it is necessary to use two brackets.

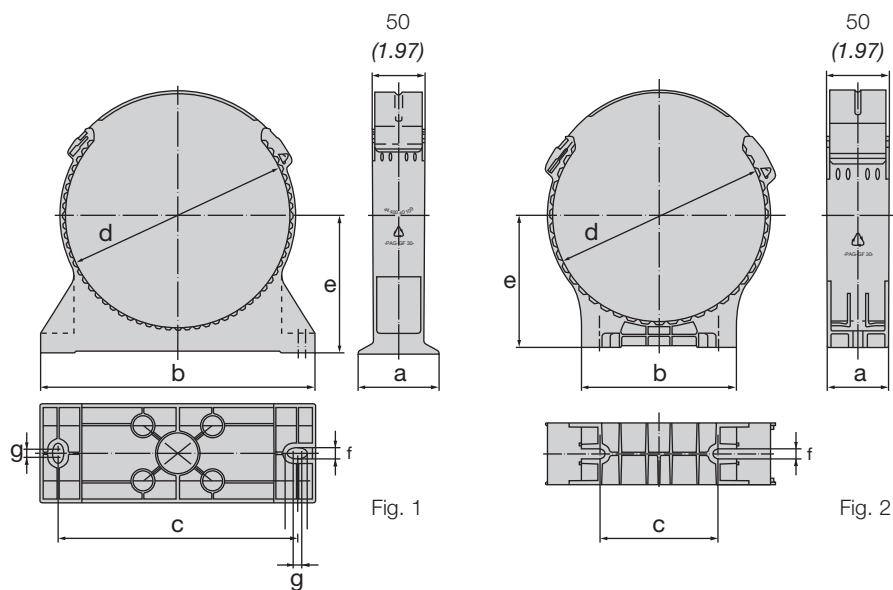

Order no.	Suitable for EUROPICLON	Fig.	Dimensions in mm (<i>Dimensions in inches</i>)						
			a	b	c	d	e	f	g
39 050 40 959	45 05x 92 ...	1	40 (1.57)	137 (5.39)	116 (4.57)	122 (4.80)	85.7 (3.37)	9 (0.35)	–
39 100 40 999	45 100 92 ...	1	60 (2.36)	205 (8.07)	175 (6.89)	156 (6.14)	105 (4.13)	8.5 (0.33)	15.5 (0.61)
39 200 40 999	45 200 92 ...	1	80 (3.15)	220 (8.66)	190 (7.48)	171 (6.73)	110 (4.33)	8.5 (0.33)	15.5 (0.61)
39 300 40 999	45 300 92 ...	1	80 (3.15)	250 (9.84)	220 (8.66)	201 (7.91)	125 (4.92)	8.5 (0.33)	15.5 (0.61)
39 400 40 999	45 400 92 ...	1	80 (3.15)	270 (10.63)	240 (9.45)	221 (8.70)	135 (5.32)	8.5 (0.33)	15.5 (0.61)
39 500 40 999	45 500 92 ...	1	80 (3.15)	310 (12.20)	280 (11.02)	262 (10.32)	155 (6.10)	8.5 (0.33)	15.5 (0.61)
39 600 40 999	45 600 92 ...	1	80 (3.15)	345 (13.58)	315 (12.40)	296 (11.65)	173 (6.81)	8.5 (0.33)	15.5 (0.61)
39 700 40 999	45 700 92 ...	1	80 (3.15)	385 (15.16)	355 (13.98)	326 (12.83)	206 (8.11)	8.5 (0.33)	7.0 (0.28)
39 800 40 999	45 800 92 ...	1	80 (3.15)	452 (17.80)	422 (16.61)	391 (15.39)	220 (8.66)	8.5 (0.33)	7.0 (0.28)
39 100 40 989	45 100 92 ...	2	50 (1.97)	110 (4.33)	80 (3.15)	156 (6.14)	100 (3.94)	8.5 (0.33)	–
39 200 40 989	45 200 92 ...	2	50 (1.97)	125 (4.92)	95 (3.74)	171 (6.73)	106 (4.17)	8.5 (0.33)	–
39 300 40 989	45 300 92 ...	2	50 (1.97)	140 (5.51)	110 (4.33)	201 (7.91)	121 (4.76)	8.5 (0.33)	–
39 400 40 989	45 400 92 ...	2	50 (1.97)	157 (6.18)	127 (5.00)	221 (8.70)	132 (5.20)	8.5 (0.33)	–
39 500 40 989	45 500 92 ...	2	50 (1.97)	182 (7.17)	152 (5.98)	262 (10.32)	153 (6.02)	8.5 (0.33)	–
39 600 40 989	45 600 92 ...	2	50 (1.97)	182 (7.17)	152 (5.98)	296 (11.65)	173 (6.81)	8.5 (0.33)	–
39 700 40 989	45 700 92 ...	2	50 (1.97)	233 (9.17)	203 (7.99)	326 (12.83)	206 (8.11)	8.5 (0.33)	–
39 800 40 989	45 800 92 ...	2	50 (1.97)	233 (9.17)	203 (7.99)	391 (15.39)	221 (8.70)	8.5 (0.33)	–



Air cleaners for compressors

NLG series



NLG

Flexible, robust, economical

MANN+HUMMEL offers a flexible and economic solution for many varied applications in the field of intake air filtration.



Advantages at a glance:

- High flexibility through variable modular system
- Economic air cleaner system through modular design
- Easy element change without tools
- Corrosion-free and robust housing through use of plastic reinforced with fibreglass
- The Piclon version with integrated dust pre-separation can also be used with medium to heavy dust loads
- As a combination air cleaner with DualSpin pre-cleaner also suitable for very difficult dust conditions due to its long service life
- Metal-free filter elements are easily disposed of by incineration and therefore are environmentally friendly with inexpensive disposal
- Problem-free adaptation to other equipment through variable connection positions
- Quick first-fit on the vehicle through threaded inserts
- Patented filter elements

NLG Pico version Single-stage air cleaners

The Pico is the single-stage version of the NLG, i.e. without integrated dust pre-separation. It is particularly suitable for applications with low dust loads where minimal pressure drop in the air cleaner is a special requirement.

These are, for example:

- Commercial vehicles (trucks)
- Buses
- Mobile cranes
- Compressors
- Stationary engines
- Generators
- Marine applications

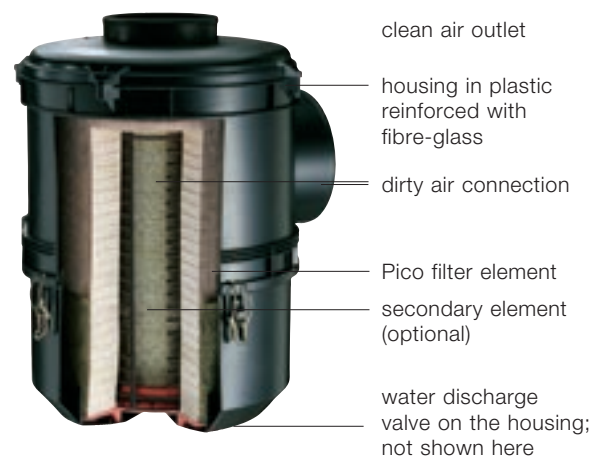

NLG Piclon version

Two-stage air cleaners with integrated pre-separation

The Piclon version is the two-stage version of the NLG with integrated dust pre-separation and an efficiency of more than 75 %. It is particularly suitable for applications with medium to heavy dust loads.

These are, for example:

- Construction and agricultural machines
- All typical Pico applications with a requirement for longer service life

The Pico and Piclon versions both have identical housing and connection dimensions. Therefore the Piclon can replace the Pico if the use of a machine in a certain region requires a special version. In this situation changing the air cleaner does not require making any changes to the pipe connections or to the fixing of the air cleaner bracket.



NLG

Filter elements

NLG Filter element:

- High dust capacity through MANN+HUMMEL graded medium
- Robust design with plastic centre tube
- Patented design
- Element protection due to integrated handle prevents damage during filter change

NLG Secondary element:

- MANN+HUMMEL synthetic fabric for high separation drop
- Secure fit in housing with screw fitting which further protects the engine as this prevents unintentional removal of the secondary element
- Robust design with plastic centre tube



NLG Pico version (1-stage)

Dimensions and part numbers

NLG Pico version with connection dimension $d_1 = 250 \text{ mm}$

Filter size	Order no.		Fig.	Nominal flow rate [m ³ /min]	Replacement filter element		Weight [kg]
	without secondary element	with secondary element			MANN-FILTER main element	MANN-FILTER secondary element	
NLG 37-37	–	44 930 85 953*	1	25 – 45	C 30 1530	CF 1830	8.3
NLG 37-42	–	44 930 85 960*	1	25 – 45	C 30 1730	CF 1840	8.7
NLG 37-42	–	44 930 85 974**	2	25 – 45	C 33 2200	CF 1840	9.4
NLG 37-42	–	44 930 85 975**	1	25 – 45	C 33 2200	CF 1840	9.4

* Pleat height 48 mm (1.89 inch)

** Pleat height 60 mm (2.36 inch)

Filter size	Order no.		Fig.	Nominal flow rate [m ³ /min]	Replacement filter element		Weight [kg]
	without secondary element	with secondary element			MANN-FILTER main element	MANN-FILTER secondary element	
NLG 15-12	44 513 85 901	44 513 85 950	1	10 – 18	C 23 513	CF 1240	3.3
	44 513 85 902	44 513 85 951	2				
	44 513 85 900	44 513 85 952	3				
NLG 15-15	44 632 85 905	44 632 85 951	1	10 – 18	C 23 632/1	CF 1250	3.6
	44 632 85 906	44 632 85 952	2				
	44 632 85 900	44 632 85 950	3				
NLG 15-18	44 750 85 903	44 750 85 951	1	10 – 18	C 23 750	CF 1260	4.3
	44 750 85 904	44 750 85 950	2				
	44 750 85 901	44 750 85 952	3				
NLG 21-18	44 742 85 905	44 742 85 950	1	12 – 24	C 25 740	CF 1420	4.3
	44 742 85 906	44 742 85 952	2				
	44 742 85 904	44 742 85 953	3				
NLG 21-21	44 860 85 908	44 860 85 952	1	12 – 24	C 25 860/5	CF 1430	4.6
	44 860 85 909	44 860 85 953	2				
	44 860 85 900	44 860 85 951	3				
NLG 21-24	44 860 85 911	44 860 85 954	1	12 – 24	C 25 990	CF 1440	5.1
	44 860 85 912	44 860 85 950	2				
	44 860 85 904	44 860 85 955	3				
NLG 28-24	44 920 85 926	44 920 85 950	1	18 – 30	C 27 1020	CF 1631	5.2
	44 920 85 927	44 920 85 955	2				
	44 920 85 916	44 920 85 956	3				
NLG 28-28	44 920 85 915	44 920 85 954	1	18 – 30	C 27 1170	CF 1640	5.6
	44 920 85 914	44 920 85 957	2				
	44 920 85 904	44 920 85 952	3				
NLG 28-32	44 920 85 928	44 920 85 958	1	18 – 30	C 27 1320/2	CF 1650	6.3
	44 920 85 924	44 920 85 951	2				
	44 920 85 918	44 920 85 959	3				
NLG 37-32	44 930 85 912	44 930 85 950	1	25 – 45	C 30 1330	CF 1820	6.4
	44 930 85 913	44 930 85 956	2				
	44 930 85 902	44 930 85 957	3				
NLG 37-37	44 930 85 908	44 930 85 958	1	25 – 45	C 30 1530	CF 1830	7.4
	44 930 85 909	44 930 85 959	2				
	44 930 85 900	44 930 85 951	3				
NLG 37-42	44 930 85 914	44 930 85 955	1	25 – 45	C 30 1730	CF 1840	7.9
	44 930 85 915	44 930 85 952	2				
	44 930 85 901	44 930 85 954	3				

NLG Pico version (1-stage)

Dimensions and part numbers

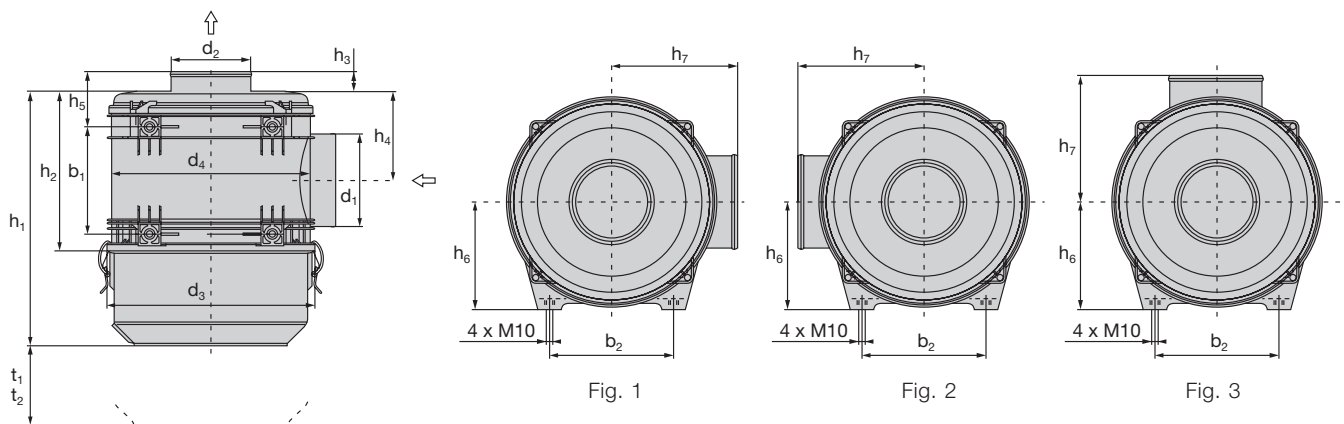

Group	Filter size	Dimensions in mm (<i>Dimensions in inches</i>)														
		d ₁	d ₂	d ₃	d ₄	b ₁	b ₂	h ₁	h ₂	h ₃	h ₄	h ₅	h ₆	h ₇	t ₁ ¹⁾	t ₂ ²⁾
15	NLG 15-12							305 (12.01)								273 (10.75)
	NLG 15-15	130 (5.12)	110 (4.33)	299 (11.77)	285 (11.22)	140 (5.51)	200 (7.87)	360 (14.17)	228 (8.98)	33 (1.30)	120 (4.72)	91 (3.59)	153 (6.02)	182 (7.17)	230 (9.06)	328 (12.91)
	NLG 15-18							415 (16.34)								383 (15.08)
21	NLG 21-18							365 (14.37)								332 (13.07)
	NLG 21-21	150 (5.91)	130 (5.12)	339 (13.35)	323 (12.72)	175 (6.89)	200 (7.87)	415 (16.34)	260 (10.24)	33 (1.30)	145.5 (5.73)	91 (3.59)	173 (6.81)	203 (7.99)	260 (10.24)	382 (15.04)
	NLG 21-24							465 (18.31)								432 (17.01)
28	NLG 28-24							427 (16.81)								395 (15.55)
	NLG 28-28	180 (7.09)	150 (5.91)	365 (14.37)	349 (13.74)	210 (8.27)	200 (7.87)	480 (18.90)	295 (11.61)	33 (1.30)	163 (6.42)	91 (3.59)	185 (7.28)	215 (8.46)	296 (11.65)	448 (17.64)
	NLG 28-32							533 (20.98)								501 (19.72)
37	NLG 37-32							498 (19.61)								465 (18.31)
	NLG 37-37	210 (8.27)	180 (7.09)	407 (16.02)	393 (15.47)	245 (9.65)	240 (9.45)	563 (22.17)	363 (14.29)	33 (1.30)	188 (7.40)	91 (3.59)	207 (8.15)	237 (9.33)	364 (14.33)	530 (20.87)
	NLG 37-42							628 (24.72)								595 (23.43)

¹⁾ Removal height without secondary element
²⁾ Removal height with secondary element

NLG Pico version (1-stage)

Flow characteristics without secondary element

Flow characteristics for flow rates as per ISO 5011

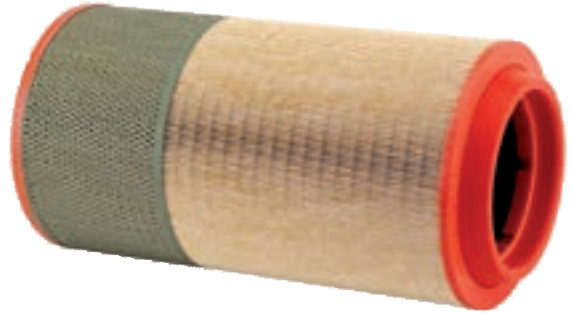
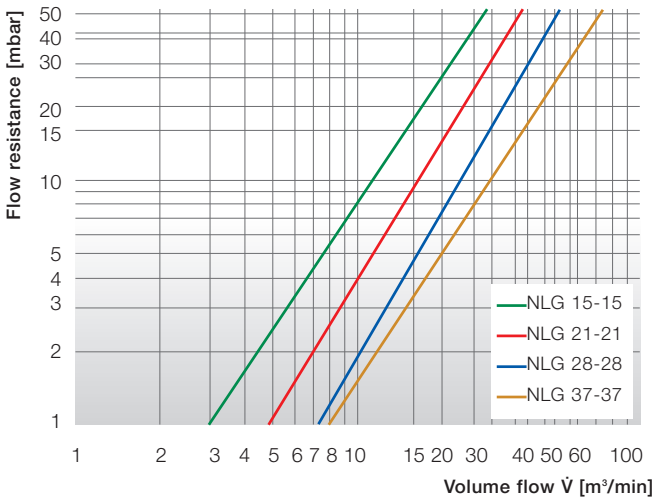

Flow characteristics for dust capacity as per ISO 5011

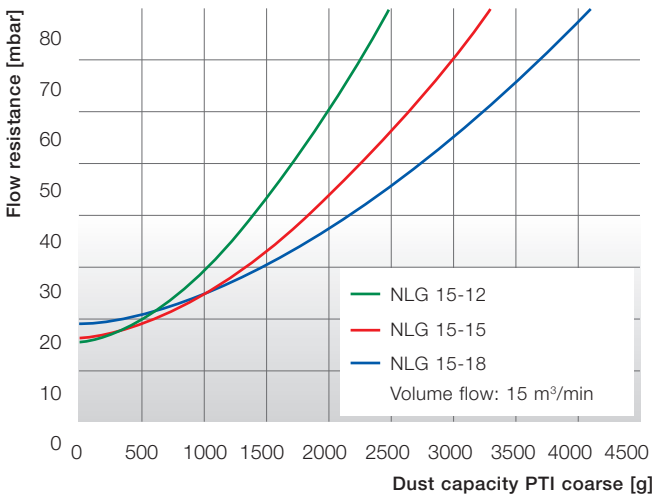

Flow characteristics for dust capacity as per ISO 5011

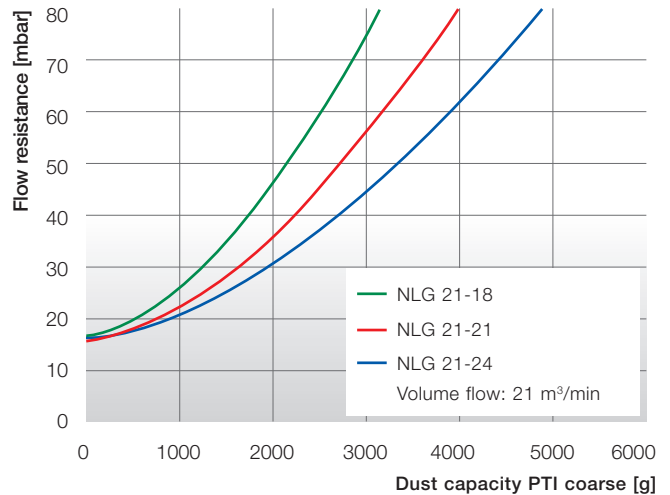

Flow characteristics for dust capacity as per ISO 5011

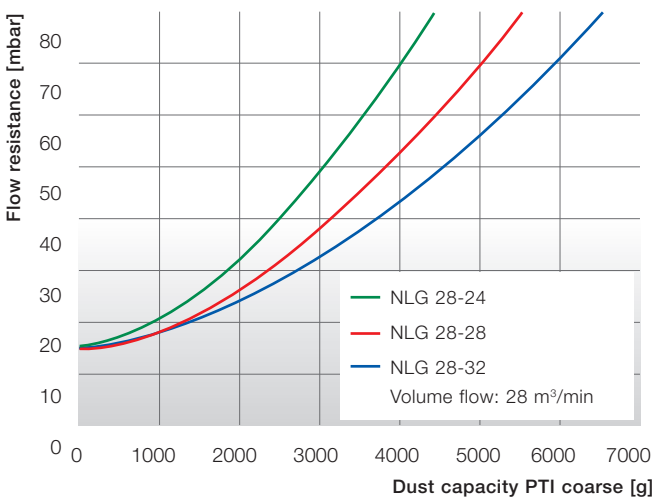

Flow characteristics for dust capacity as per ISO 5011

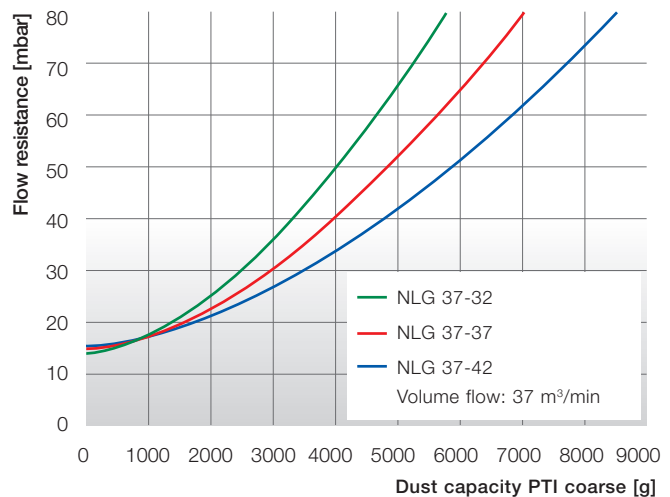

NLG Pico version (1-stage)

Flow characteristics with secondary element

Flow characteristics for flow rates as per ISO 5011

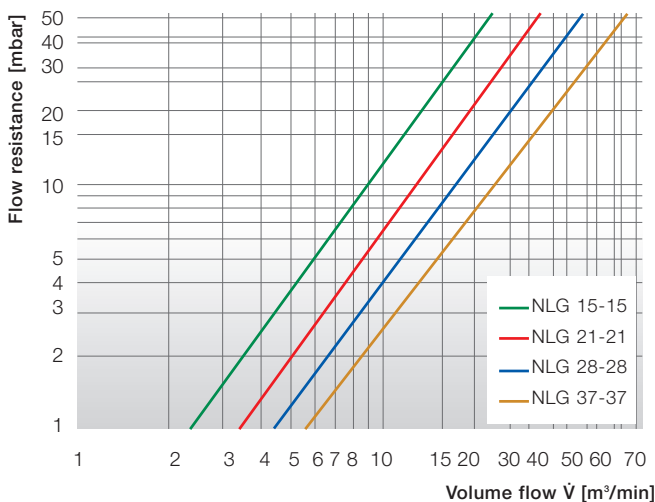

Flow characteristics for flow rates as per ISO 5011

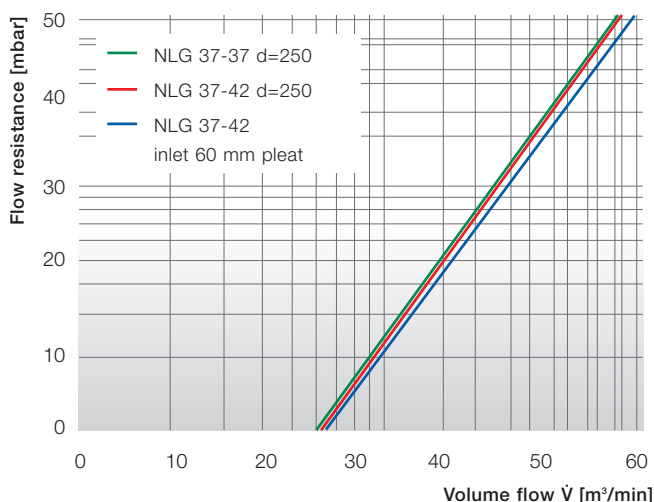

Flow characteristics for dust capacity as per ISO 5011

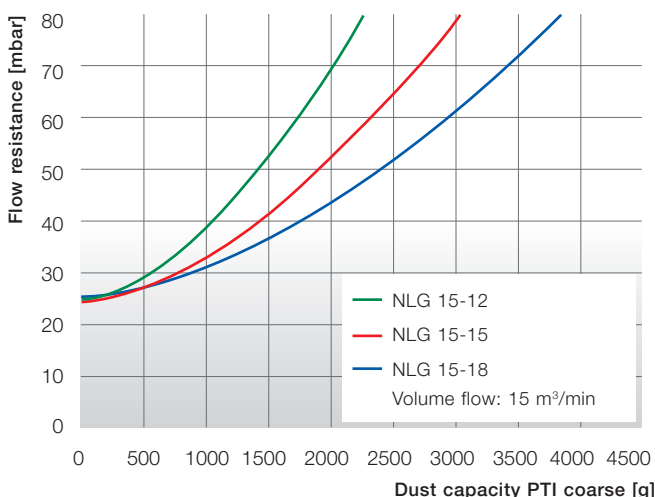

Flow characteristics for dust capacity as per ISO 5011

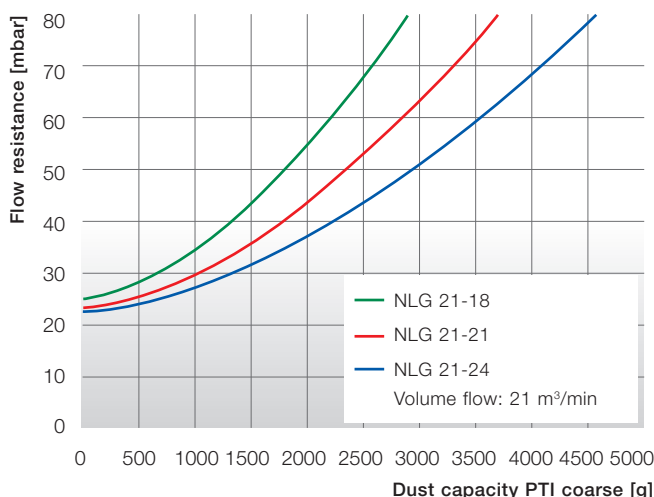

Flow characteristics for dust capacity as per ISO 5011

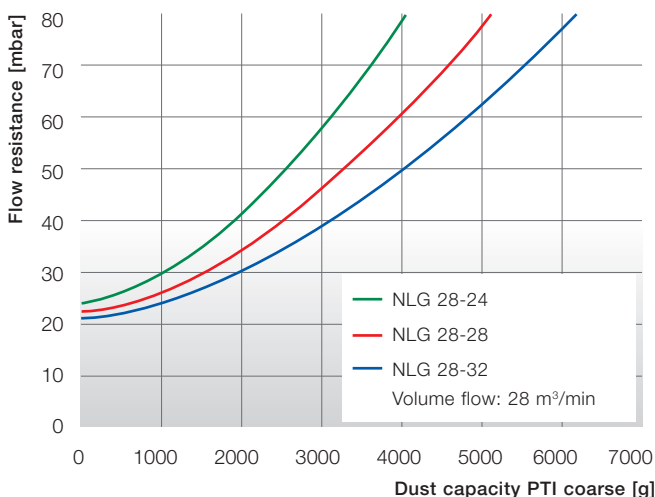

Flow characteristics for dust capacity as per ISO 5011

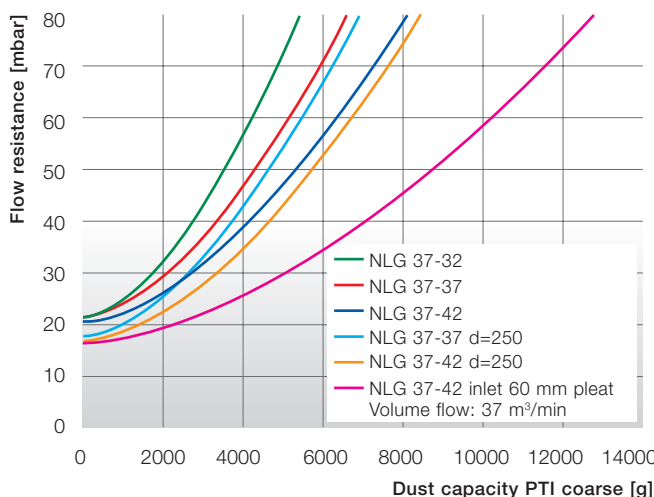

NLG Piclon version (2-stage)

Dimensions and part numbers

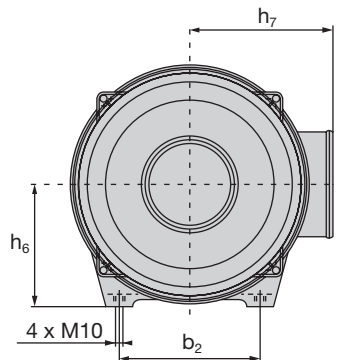

Fig. 1

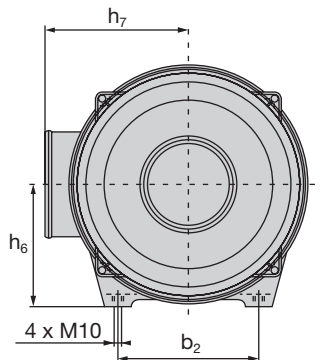

Fig. 2

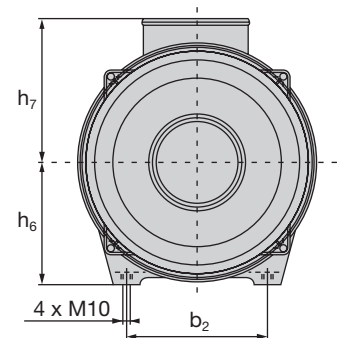
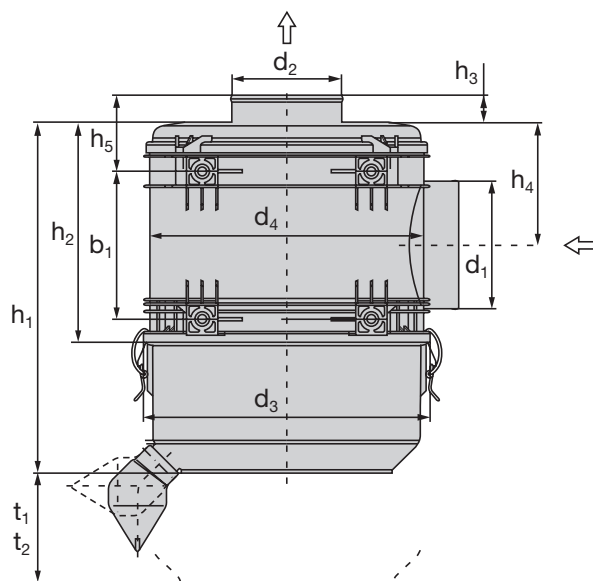

Fig. 3

Filter size	Order no.		Fig.	Nominal flow rate [m ³ /min]	Replacement filter element		Weight [kg]
	without secondary element	with secondary element			MANN-FILTER main element	MANN-FILTER secondary element	
NLG 15-15	44 526 92 900	44 526 92 951	1	10 – 15	C 22 526/1	CF 1250	3.6
	44 526 92 901	44 526 92 952	2				
	44 526 92 902	44 526 92 950	3				
NLG 15-18	44 625 92 901	44 625 92 951	1	10 – 15	C 22 625	CF 1260	4.3
	44 625 92 902	44 625 92 952	2				
	44 625 92 900	44 625 92 950	3				
NLG 21-21	44 722 92 905	44 722 92 954	1	15 – 21	C 24 745/1	CF 1430	4.6
	44 722 92 906	44 722 92 953	2				
	44 722 92 904	44 722 92 950	3				
NLG 21-24	44 722 92 907	44 722 92 956	1	15 – 21	C 24 820	CF 1440	5.1
	44 722 92 908	44 722 92 957	2				
	44 722 92 903	44 722 92 951	3				
NLG 28-28	44 920 92 906	44 920 92 956	1	20 – 28	C 26 980	CF 1640	5.6
	44 920 92 907	44 920 92 954	2				
	44 920 92 902	44 920 92 950	3				
NLG 28-32	44 920 92 908	44 920 92 957	1	20 – 28	C 26 1100	CF 1650	6.3
	44 920 92 909	44 920 92 958	2				
	44 920 92 903	44 920 92 951	3				
NLG 37-37	44 930 92 902	44 930 92 950	1	25 – 40	C 28 1275	CF 1830	7.4
	44 930 92 903	44 930 92 953	2				
	44 930 92 900	44 930 92 951	3				
NLG 37-42	44 930 92 904	44 930 92 954	1	25 – 40	C 28 1440	CF 1840	7.9
	44 930 92 905	44 930 92 955	2				
	44 930 92 901	44 930 92 952	3				

NLG Piclon version (2-stage)

Dimensions and part numbers



Group	Filter size	Dimensions in mm (<i>Dimensions in inches</i>)														
		d ₁	d ₂	d ₃	d ₄	b ₁	b ₂	h ₁	h ₂	h ₃	h ₄	h ₅	h ₆	h ₇	t ₁ ¹⁾	t ₂ ²⁾
15	NLG 15-15	130	110	299	285	140	200	360 (14.17)	228	33	120	91	153	182	230	328 (12.91)
	NLG 15-18	130 (5.12)	110 (4.33)	299 (11.77)	285 (11.22)	140 (5.51)	200 (7.87)	415 (16.34)	228 (8.98)	33 (1.30)	120 (4.72)	91 (3.59)	153 (6.02)	182 (7.17)	230 (9.06)	383 (15.08)
21	NLG 21-21	150	130	339	323	175	200	415 (16.34)	260	33	145.5	91	173	203	260	382 (15.04)
	NLG 21-24	150 (5.91)	130 (5.12)	339 (13.35)	323 (12.72)	175 (6.89)	200 (7.87)	465 (18.31)	260 (10.24)	33 (1.30)	145.5 (5.73)	91 (3.59)	173 (6.81)	203 (7.99)	260 (10.24)	432 (17.01)
28	NLG 28-28	180	150	365	349	210	200	480 (18.90)	295	33	163	91	185	215	296	448 (17.64)
	NLG 28-32	180 (7.09)	150 (5.91)	365 (14.37)	349 (13.74)	210 (8.27)	200 (7.87)	533 (20.98)	295 (11.61)	33 (1.30)	163 (6.42)	91 (3.59)	185 (7.28)	215 (8.46)	296 (11.65)	501 (19.72)
37	NLG 37-37	210	180	407	393	245	240	563 (22.17)	363	33	188	91	207	237	364	530 (20.87)
	NLG 37-42	210 (8.27)	180 (7.09)	407 (16.02)	393 (15.47)	245 (9.65)	240 (9.45)	628 (24.72)	363 (14.29)	33 (1.30)	188 (7.40)	91 (3.59)	207 (8.15)	237 (9.33)	364 (14.33)	595 (23.43)

¹⁾ Removal height without secondary element

²⁾ Removal height with secondary element

NLG Piclon version (2-stage)

Flow characteristics without secondary element

Flow characteristics for flow rates as per ISO 5011

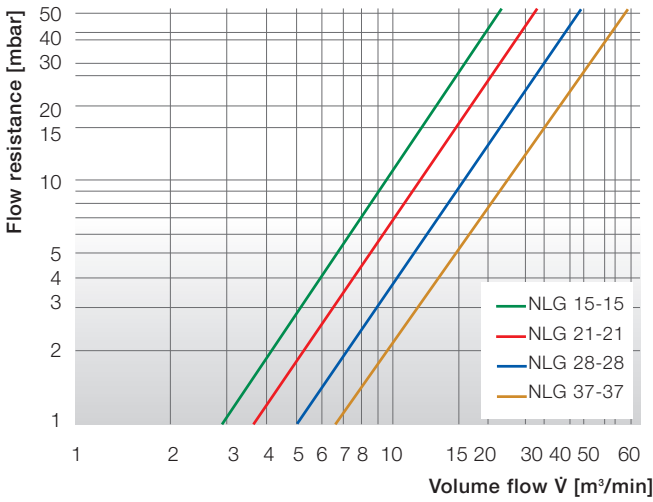

Flow characteristics for dust capacity as per ISO 5011

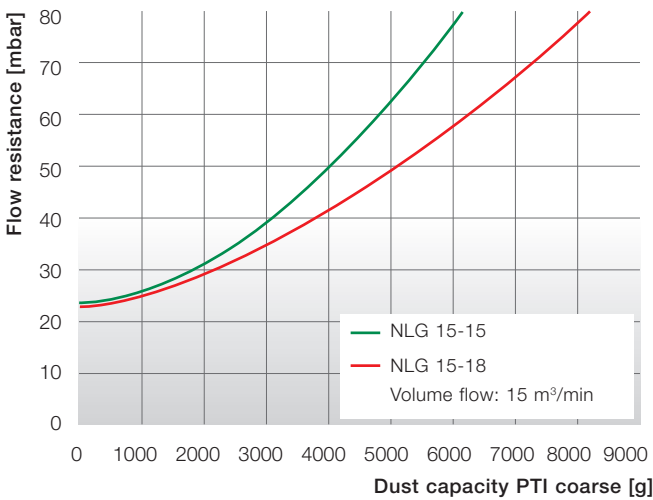

Flow characteristics for dust capacity as per ISO 5011

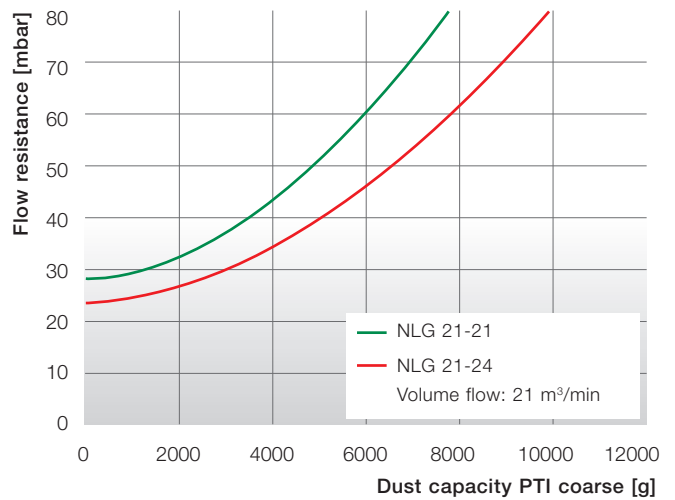

Flow characteristics for dust capacity as per ISO 5011

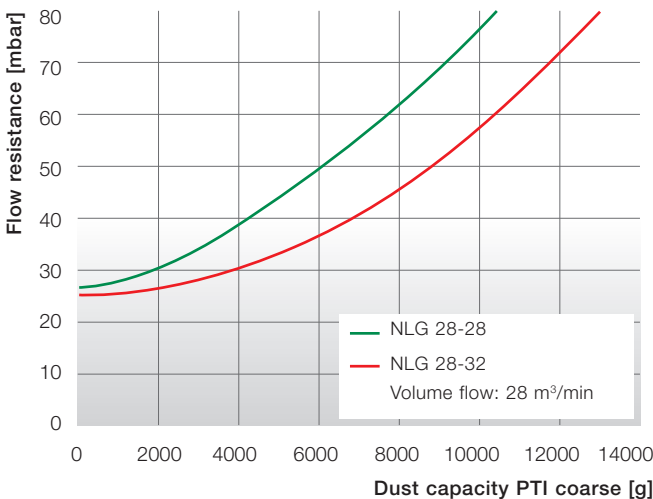

Flow characteristics for dust capacity as per ISO 5011

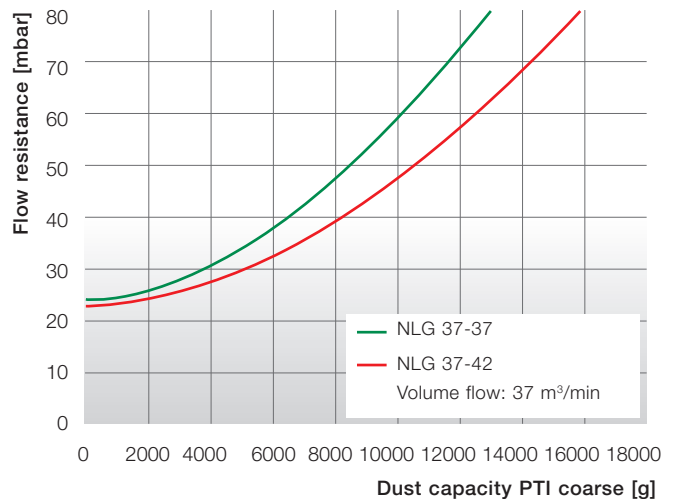

NLG Piclon version (2-stage)

Flow characteristics with secondary element

Flow characteristics for flow rates as per ISO 5011

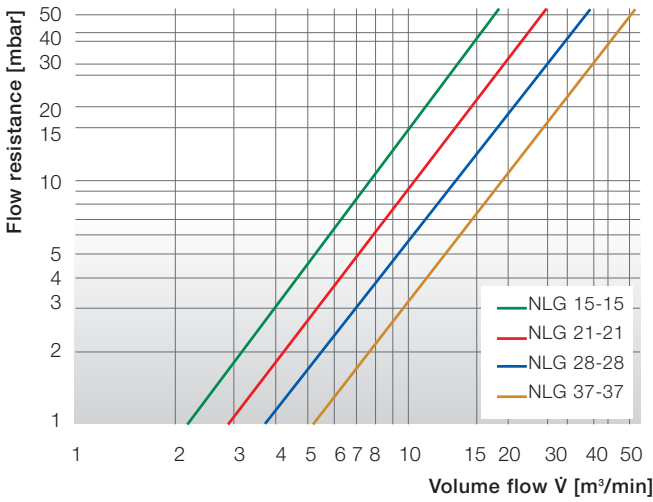

Flow characteristics for dust capacity as per ISO 5011

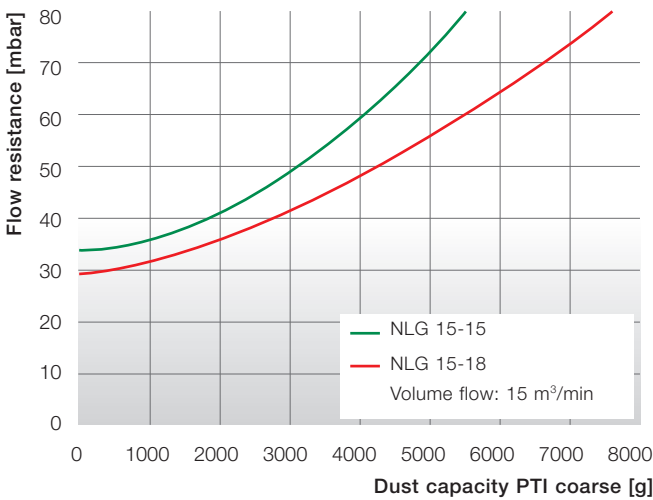

Flow characteristics for dust capacity as per ISO 5011

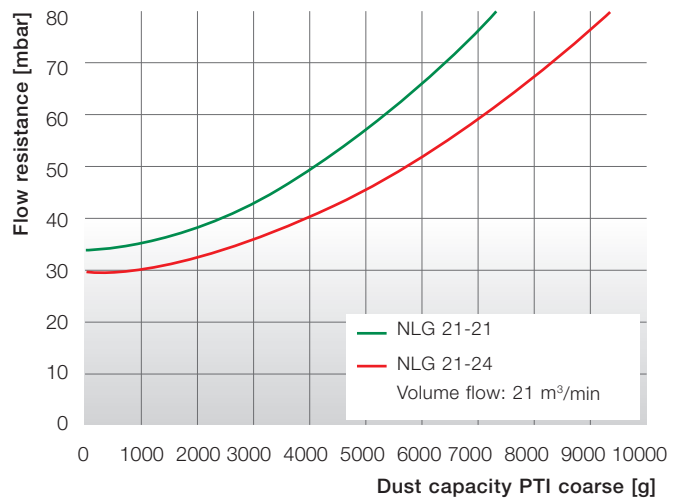

Flow characteristics for dust capacity as per ISO 5011

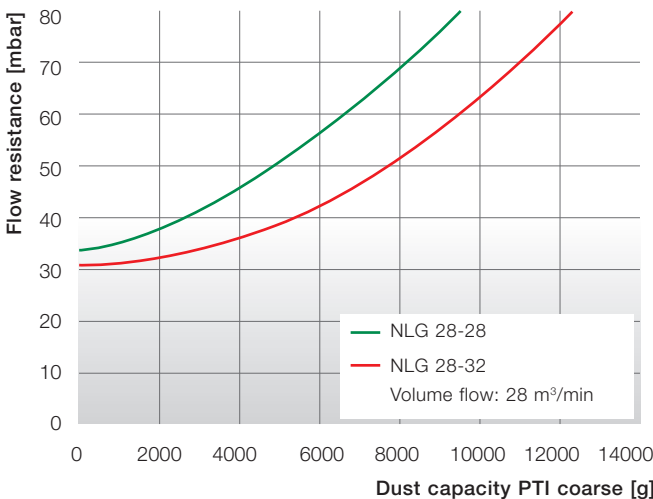

Flow characteristics for dust capacity as per ISO 5011

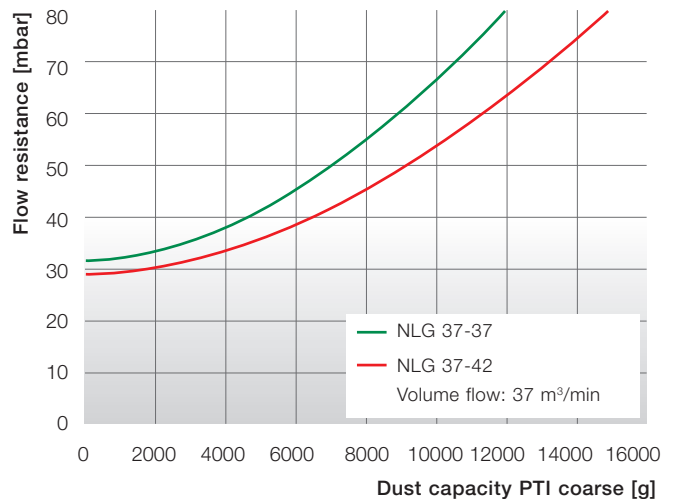

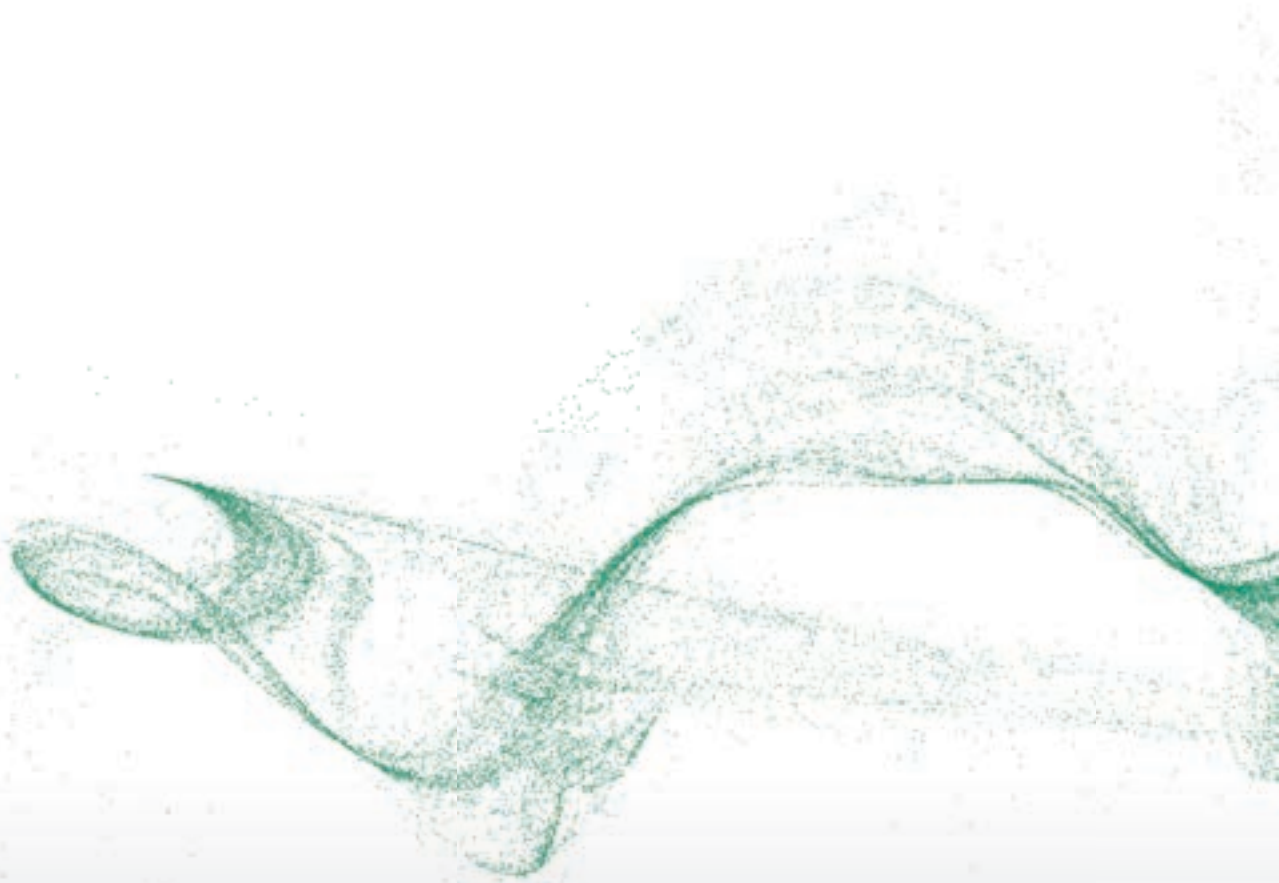

Air cleaners for compressors

Picolino series



Picolino

Compact air cleaner for high requirements



The Picolino line from MANN+HUMMEL offers exceptional filtration in a compact installation space with excellent flexibility. The Picolino line is available with a number of different connections to enable it to adapt to different applications.

Applications:

The air cleaners of the Picolino line are available with a number of connection fittings and are, for example, suitable for:

- Silencer air cleaners for low-noise air intake, e.g. in small piston compressors
- Intake air cleaners for small engines (lawn mowers, power generators, etc.)
- Two-way ventilation air cleaners for gear units and tanks for liquids

Advantages at a glance:

- Excellent flexibility through variable modular system
- Economical air cleaner system through combination of standard parts
- Easy element change without tools
- Corrosion-free and robust housing through use of plastic reinforced with fibre-glass
- Cr(VI)-free
- Temperature resistant to +120 °C (for short periods)
- Material with high temperature stability available for adapters on request
- Quick response to customised filtration solutions
- Metal-free filter elements are easily disposed of by incineration and therefore are environmentally friendly with inexpensive disposal
- Patented filter elements with radial seal

Picolino

Picolino modular system

The product line consists of five master housings with various adapter pieces which can be used to adapt the cleaner to the individual requirements of customised applications. The housing, adapters and filter elements are free of metal. Depending on the design, the system covers nominal flow rates from 0.15 m³/min to 3.2 m³/min.

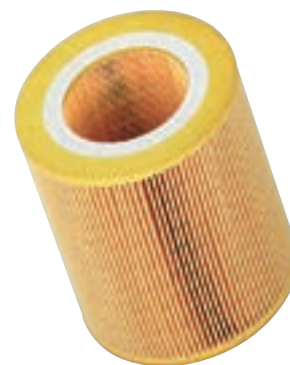
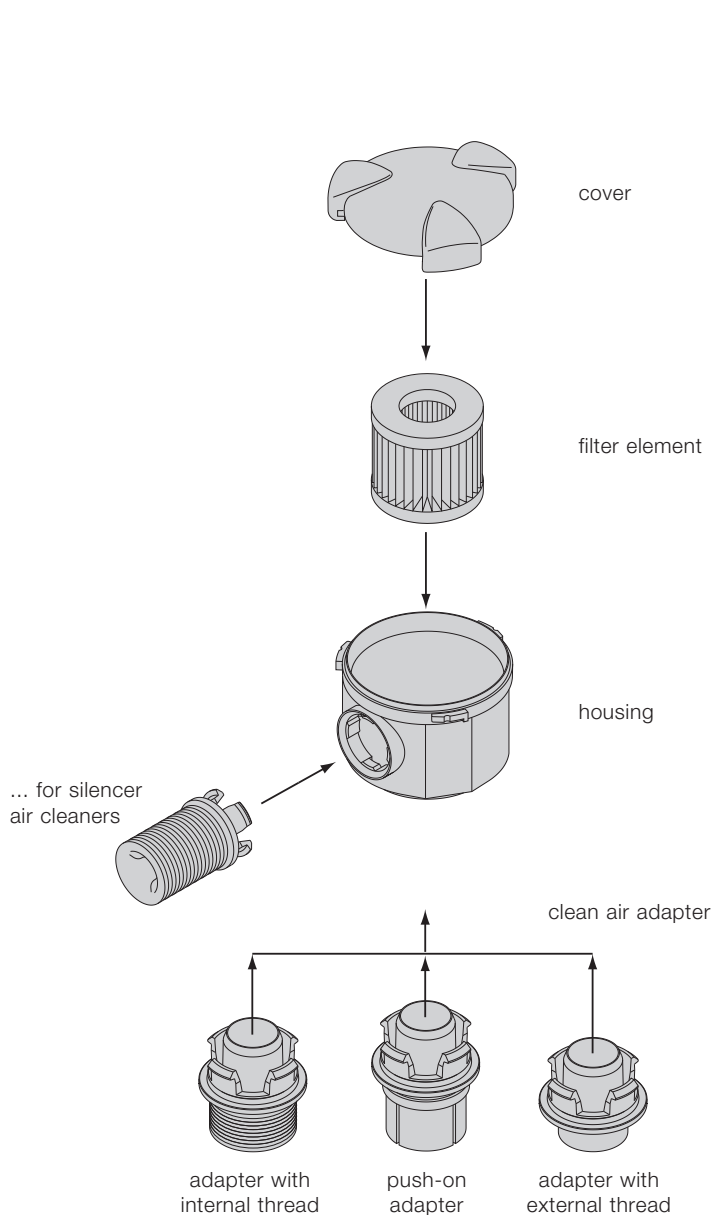

Filter elements

- High dust capacity through special MANN+HUMMEL filter medium
- Radial seal through elastomer end plates (protected by patents)
- Reliable pleat stabilisation prevents pleats sticking together under unfavourable conditions

Picolino Intake air cleaners (two-way ventilation air cleaners)

Dimensions and part numbers

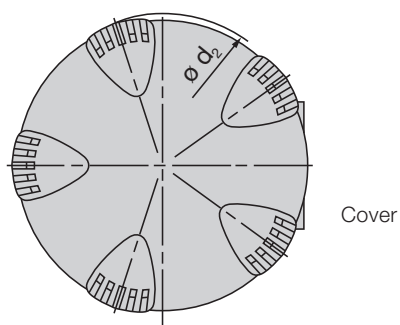

Fig. 1

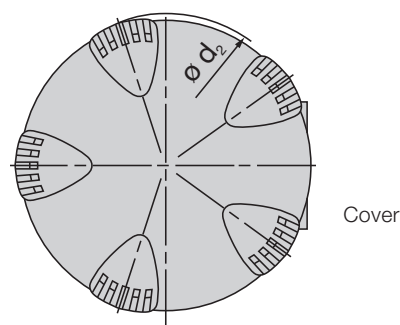

Fig. 2

Order no.	Fig.	Nominal flow rate [m ³ /min] ¹⁾	Dimensions in mm (<i>Dimensions in inches</i>)							MANN-FILTER main element
			d ₁	d ₂	e ₁	h ₁	h ₂	l	t	
44 010 72 996	2	0.25	G 1/2 ³⁾	58 (2.28)	14 (0.55)	61 (2.40)	34 (1.34)	27 (1.06)	30 (1.18)	C 410
44 010 72 997	2	0.2	G 3/8 ³⁾	58 (2.28)	11 (0.43)	61 (2.40)	34 (1.34)	27 (1.06)	30 (1.18)	C 410
44 010 72 999	2	0.2	M 18x1.5 ²⁾	58 (2.28)	10 (0.39)	61 (2.40)	34 (1.34)	27 (1.06)	30 (1.18)	C 410
44 010 77 999	1	0.25	35 (1.38)	58 (2.28)	23 (0.91)	73 (2.87)	64 (2.52)	27 (1.06)	30 (1.18)	C 410
44 020 72 996	2	0.25	G 1/2 ³⁾	68 (2.68)	14 (0.55)	62 (2.44)	34 (1.34)	31 (1.22)	30 (1.18)	C 420
44 020 72 997	2	0.25	G 3/8 ³⁾	68 (2.68)	11 (0.43)	62 (2.44)	34 (1.34)	31 (1.22)	30 (1.18)	C 420
44 020 72 999	2	0.2	M 18x1.5 ²⁾	68 (2.68)	11 (0.43)	62 (2.44)	34 (1.34)	31 (1.22)	30 (1.18)	C 420
44 020 77 999	1	0.25	35 (1.38)	68 (2.68)	23 (0.91)	74 (2.91)	46 (1.81)	31 (1.22)	30 (1.18)	C 420
44 030 72 999	2	0.8	G 3/4 ³⁾	102 (4.02)	15 (0.59)	94 (3.70)	45 (1.77)	48 (1.89)	68 (2.68)	C 630
44 030 77 997	1	1.2	40 (1.57)	102 (4.02)	25 (0.98)	116 (4.57)	67 (2.64)	48 (1.89)	68 (2.68)	C 630
44 030 77 998	1	1.2	30 (1.18)	102 (4.02)	23 (0.91)	116 (4.57)	67 (2.64)	48 (1.89)	68 (2.68)	C 630

¹⁾ The nominal flow rate relates to flow resistance of 15 mbar. The flow rate depends on the cross-section of the clean air outlet.

²⁾ External thread

³⁾ Internal thread

Picolino Intake air cleaners (two-way ventilation air cleaners)

Dimensions and part numbers

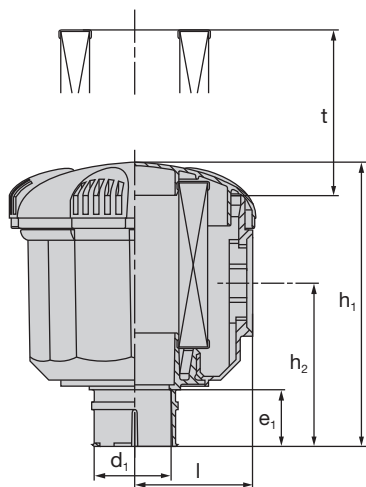

Fig. 1

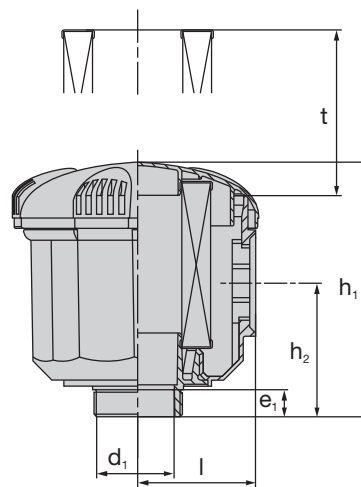

Fig. 2

Order no.	Fig.	Nominal flow rate [m ³ /min] ¹⁾	Dimensions in mm (<i>Dimensions in inches</i>)							MANN-FILTER main element
			d ₁	d ₂	e ₁	h ₁	h ₂	l	t	
44 030 77 999	1	0.7	20 (0.79)	102 (4.02)	23 (0.91)	116 (4.57)	67 (2.64)	48 (1.89)	68 (2.68)	C 630
44 040 72 999	2	2.1	G 1¼ ³⁾	145 (5.71)	19 (0.75)	131 (5.16)	71 (2.80)	69 (2.72)	79 (3.11)	C 1140
44 040 77 996	1	3.0	71 (2.8)	145 (5.71)	25 (0.98)	136 (5.35)	76 (2.99)	69 (2.72)	79 (3.11)	C 1140
44 040 77 997	1	2.8	60 (2.36)	145 (5.71)	25 (0.98)	136 (5.35)	76 (2.99)	69 (2.72)	79 (3.11)	C 1140
44 040 77 998	1	2.6	52 (2.05)	145 (5.71)	25 (0.98)	136 (5.35)	76 (2.99)	69 (2.72)	79 (3.11)	C 1140
44 040 77 999	1	2.1	40 (1.57)	145 (5.71)	25 (0.98)	136 (5.35)	76 (2.99)	69 (2.72)	79 (3.11)	C 1140
44 050 72 999	2	2.3	G 1¼ ³⁾	181 (7.13)	19 (0.75)	188 (7.40)	112 (4.41)	86 (3.39)	135 (5.32)	C 1250
44 050 77 996	1	3.5	71 (2.8)	181 (7.13)	25 (0.98)	193 (7.60)	117 (4.61)	86 (3.39)	135 (5.32)	C 1250
44 050 77 997	1	3.4	60 (2.36)	181 (7.13)	25 (0.98)	193 (7.60)	117 (4.61)	86 (3.39)	135 (5.32)	C 1250
44 050 77 998	1	3.1	52 (2.05)	181 (7.13)	25 (0.98)	193 (7.60)	117 (4.61)	86 (3.39)	135 (5.32)	C 1250
44 050 77 999	1	2.3	40 (1.57)	181 (7.13)	25 (0.98)	193 (7.60)	117 (4.61)	86 (3.39)	135 (5.32)	C 1250

¹⁾ The nominal flow rate relates to flow resistance of 15 mbar. The flow rate depends on the cross-section of the clean air outlet.

²⁾ External thread

³⁾ Internal thread

Picolino Silencer air cleaners

Dimensions and part numbers

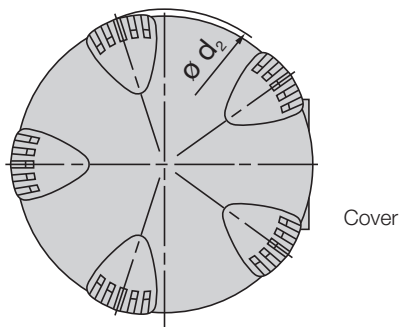

Fig. 1

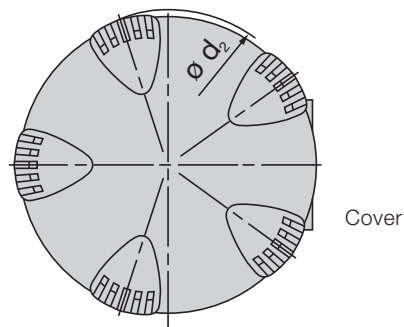

Fig. 2

Order no.	Fig.	Nominal flow rate [m ³ /min] ¹⁾	Dimensions in mm (<i>Dimensions in inches</i>)								MANN-FILTER main element
			d ₁	d ₂	e ₁	e ₂	h ₁	h ₂	l	t	
44 010 82 996	2	0.15	G ½ ³⁾	58 (2.28)	14 (0.55)	29 (1.14)	61 (2.40)	34 (1.34)	56 (2.20)	30 (1.18)	C 410
44 010 82 997	2	0.15	G ¾ ³⁾	58 (2.28)	11 (0.43)	29 (1.14)	61 (2.40)	34 (1.34)	56 (2.20)	30 (1.18)	C 410
44 010 82 999	2	0.15	M 18x1.5 ²⁾	58 (2.28)	10 (0.39)	29 (1.14)	61 (2.40)	34 (1.34)	56 (2.20)	30 (1.18)	C 410
44 010 87 999	1	0.15	35 (1.38)	58 (2.28)	23 (0.91)	29 (1.14)	73 (2.87)	46 (1.81)	56 (2.20)	30 (1.18)	C 410
44 020 82 996	2	0.15	G ½ ³⁾	68 (2.68)	14 (0.55)	29 (1.14)	62 (2.44)	34 (1.34)	60 (2.36)	30 (1.18)	C 420
44 020 82 997	2	0.15	G ¾ ³⁾	68 (2.68)	11 (0.43)	29 (1.14)	62 (2.44)	34 (1.34)	60 (2.36)	30 (1.18)	C 420
44 020 82 999	2	0.15	M 18x1.5 ²⁾	68 (2.68)	10 (0.39)	29 (1.14)	62 (2.44)	34 (1.34)	60 (2.36)	30 (1.18)	C 420
44 020 87 999	1	0.15	35 (1.38)	68 (2.68)	23 (0.91)	29 (1.14)	74 (2.91)	46 (1.81)	60 (2.36)	30 (1.18)	C 420
44 030 82 999	2	0.6	G ¾ ³⁾	102 (4.02)	15 (0.59)	47 (1.85)	94 (3.70)	45 (1.77)	95 (3.74)	68 (2.68)	C 630
44 030 87 997	1	0.8	40 (1.57)	102 (4.02)	25 (0.98)	47 (1.85)	116 (4.57)	67 (2.64)	95 (3.74)	68 (2.68)	C 630
44 030 87 998	1	0.8	30 (1.18)	102 (4.02)	23 (0.91)	47 (1.85)	116 (4.57)	67 (2.64)	95 (3.74)	68 (2.68)	C 630

¹⁾ The nominal flow rate relates to flow resistance of 15 mbar. The flow rate depends on the cross-section of the clean air outlet.

²⁾ External thread

³⁾ Internal thread

Picolino Silencer air cleaners

Dimensions and part numbers

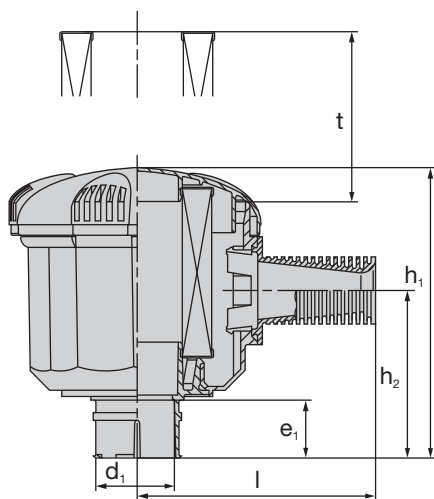

Fig. 1

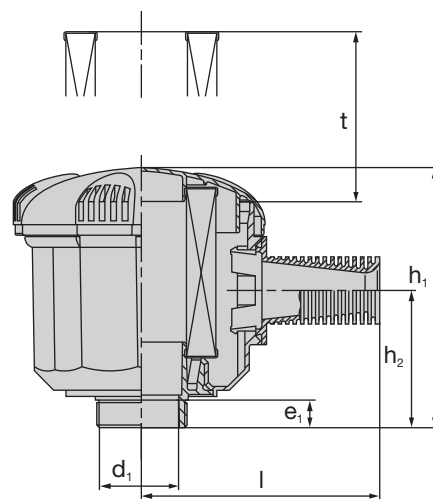

Fig. 2

Order no.	Fig.	Nominal flow rate [m ³ /min] ¹⁾	Dimensions in mm (<i>Dimensions in inches</i>)								MANN-FILTER main element
			d ₁	d ₂	e ₁	e ₂	h ₁	h ₂	l	t	
44 030 87 999	1	0.5	20 (0.79)	102 (4.02)	23 (0.91)	47 (1.85)	116 (4.57)	67 (2.64)	95 (3.74)	68 (2.68)	C 630
44 040 82 999	2	1.7	G 1¼ ³⁾	145 (5.71)	19 (0.75)	55 (2.17)	131 (5.16)	71 (2.80)	79 (3.11)	79 (3.11)	C 1140
44 040 87 996	1	2.0	71 (2.8)	145 (5.71)	25 (0.98)	55 (2.17)	136 (5.35)	76 (2.99)	79 (3.11)	79 (3.11)	C 1140
44 040 87 997	1	2.0	60 (2.36)	145 (5.71)	25 (0.98)	53 (2.09)	136 (5.35)	76 (2.99)	116 (4.57)	79 (3.11)	C 1140
44 040 87 998	1	1.9	52 (2.05)	145 (5.71)	25 (0.98)	53 (2.09)	136 (5.35)	76 (2.99)	116 (4.57)	79 (3.11)	C 1140
44 040 87 999	1	1.6	40 (1.57)	145 (5.71)	25 (0.98)	53 (2.09)	136 (5.35)	76 (2.99)	116 (4.57)	79 (3.11)	C 1140
44 050 82 999	2	2.0	G 1¼ ³⁾	181 (7.13)	19 (0.75)	55 (2.17)	188 (7.40)	112 (4.41)	133 (5.24)	135 (5.32)	C 1250
44 050 87 996	1	2.8	71 (2.8)	181 (7.13)	25 (0.98)	55 (2.17)	193 (7.60)	117 (4.61)	133 (5.24)	135 (5.32)	C 1250
44 050 87 997	1	2.8	60 (2.36)	181 (7.13)	25 (0.98)	59 (2.32)	193 (7.60)	117 (4.61)	133 (5.24)	135 (5.32)	C 1250
44 050 87 998	1	2.5	52 (2.05)	181 (7.13)	25 (0.98)	59 (2.32)	193 (7.60)	117 (4.61)	133 (5.24)	135 (5.32)	C 1250
44 050 87 999	1	2.0	40 (1.57)	181 (7.13)	25 (0.98)	59 (2.32)	193 (7.60)	117 (4.61)	133 (5.24)	135 (5.32)	C 1250

¹⁾ The nominal flow rate relates to flow resistance of 15 mbar. The flow rate depends on the cross-section of the clean air outlet.

²⁾ External thread

³⁾ Internal thread

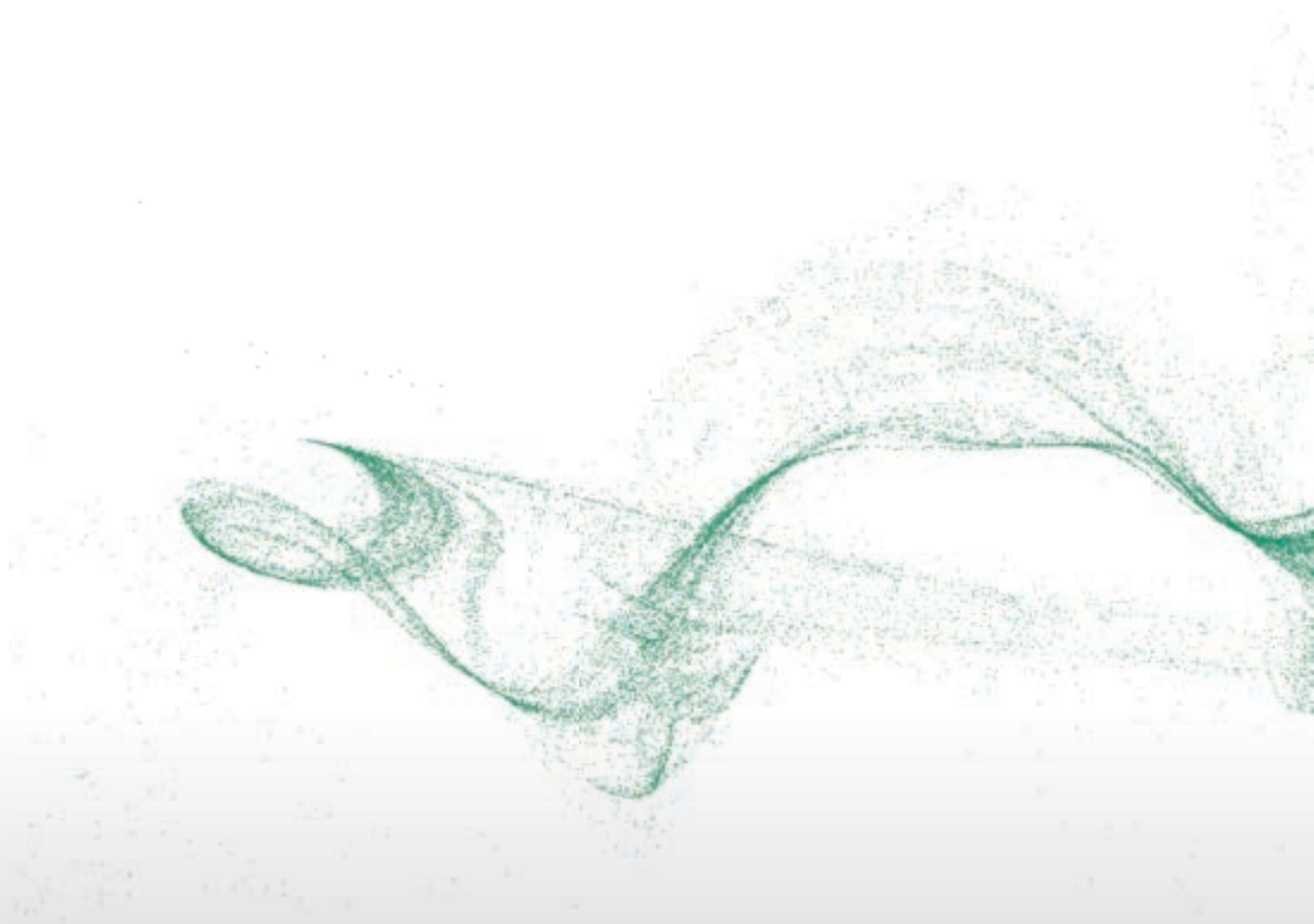

Air cleaners for compressors

Picolight series



Picolight

Single stage air cleaners without housing

The metal-free air cleaners of the Picolight line from MANN+HUMMEL are characterised by an especially low-weight and compact design. We particularly recommend these air cleaners for use in stationary applications with low dust loads such as generators, compressors, marine engines, etc.



Advantages at a glance:

- Low pressure drop
- Very economical
- Compact design
- Metal-free design
- Excellent filtration performance
- Cr(VI)-free

Technical information

Use of MANN+HUMMEL standard high quality filter media achieves high separation efficiency and filtration performance in the Picolight. The Picolight is recommended for use in installation areas which are enclosed or protected against humidity. The types shown here cover volumetric flows from 1 m³/min to 100 m³/min. A tensioning strap is required to mount the air cleaner.

Flow characteristics

Flow characteristics for flow rates as per ISO 5011

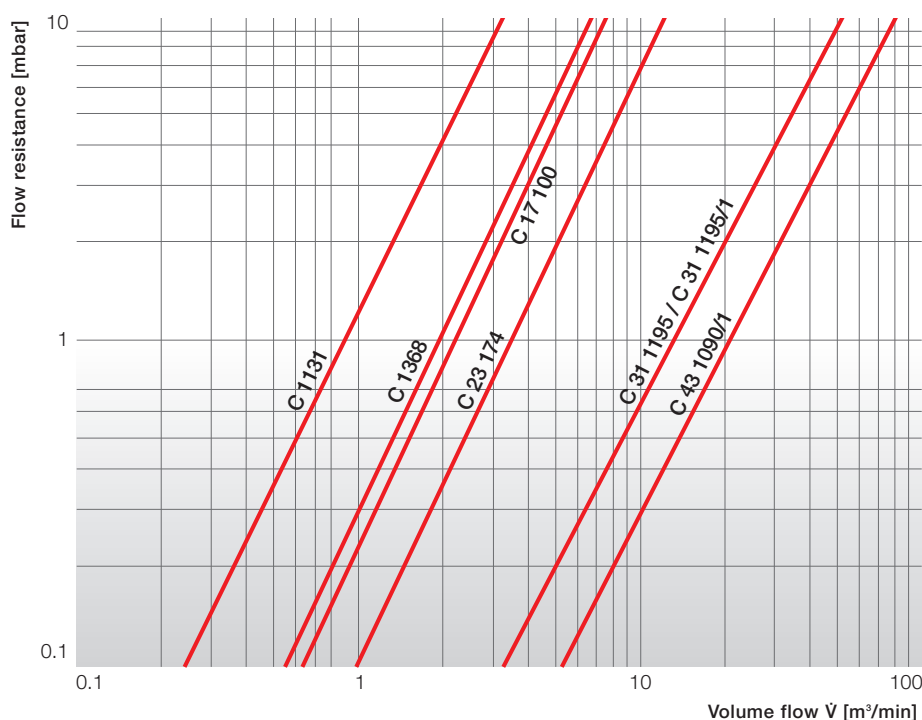

Picolight

Dimensions and part numbers

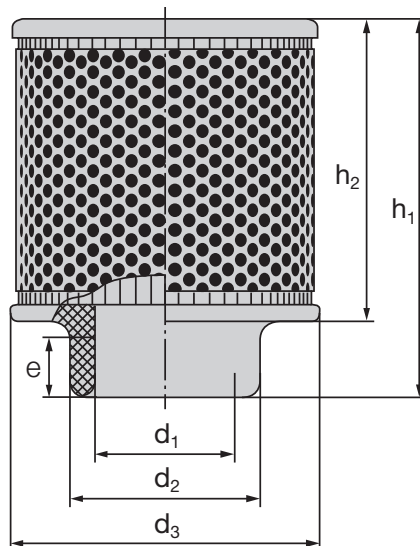

MANN-FILTER	Nominal flow rate ¹⁾ [m ³ /min]	Dimensions in mm (<i>Dimensions in inches</i>)						Weight [kg]	Tightening strap
		d_1	d_2	d_3	h_1	h_2	e		
C 1131	3.3	50 (1.97)	65 (2.56)	110 (4.33)	120 (4.72)	95 (3.74)	20 (0.79)	0.16	02 018 01 709
C 1368	6.8	76 (2.99)	90 (3.54)	130 (5.12)	150 (5.91)	125 (4.92)	20 (0.79)	0.24	02 018 01 712
C 17 100	7.7	76 (2.99)	90 (3.54)	160 (6.30)	165 (6.50)	140 (5.51)	25 (0.98)	0.38	02 018 01 712
C 23 174	12.5	100 (3.94)	120 (4.72)	230 (9.06)	156 (6.14)	120 (4.72)	30 (1.18)	0.68	02 018 01 715
C 31 1195	40	198 (7.8)	198 (7.8)	318 (12.52)	444 (17.48)	400 (15.75)	40 (1.57)	3.3	02 018 01 724
C 31 1195/1	40	198 (7.8)	198 (7.8)	318 (12.52)	444 (17.48)	400 (15.75)	40 (1.57)	3.2	02 018 01 724
C 43 1090/1	80	250 (9.84)	260 (10.24)	425 (16.73)	404 (15.91)	335 (13.19)	80 (3.15)	5.6	02 018 01 728

¹⁾ The nominal flow rate relates to flow resistance of 10 mbar.

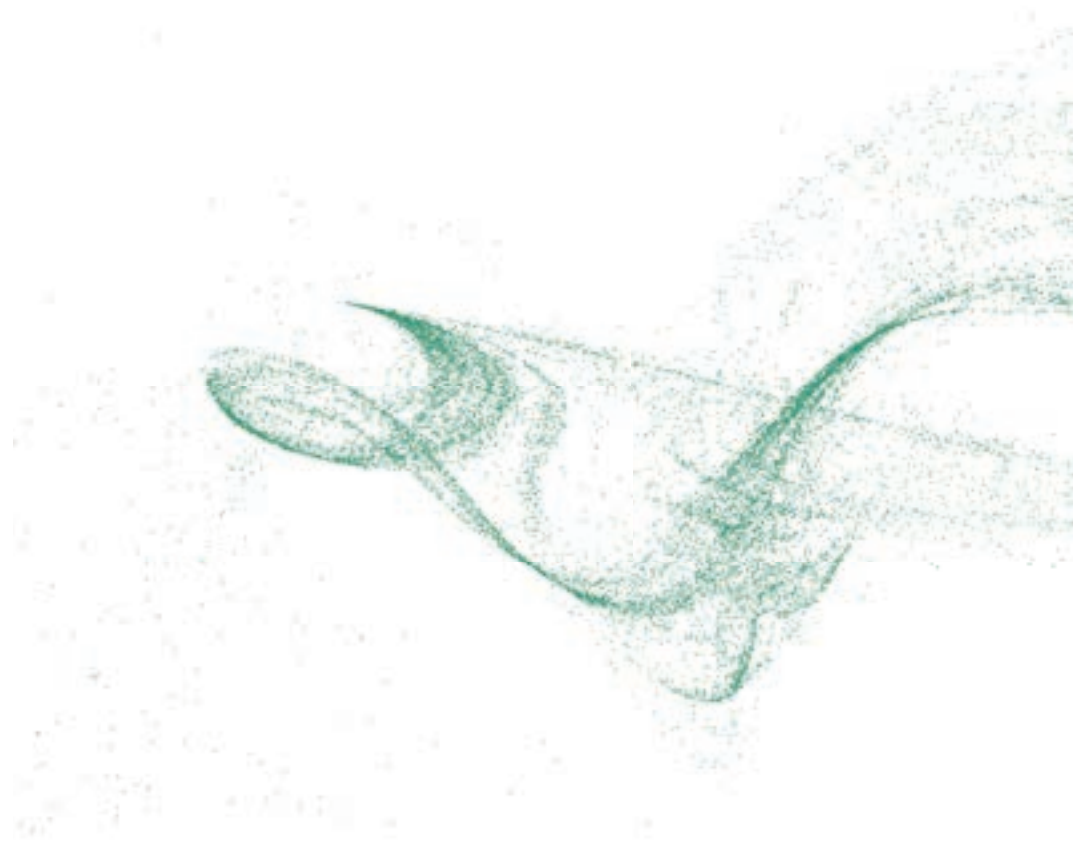

System accessories for air cleaners



Accessories

The reliable operation of intake air cleaners for internal combustion engines and compressors must also be ensured under the most difficult operating conditions. This is only possible if the air cleaner and the accessories are perfectly matched to each other.

MANN+HUMMEL offers a comprehensive range of accessories for all air cleaners especially designed for the respective type of air cleaner. These are proven products which offer reliability and long life in numerous applications – also under the hardest operating conditions.

Content

Rain caps	from page 100
Protect against ingress of water and coarse dirt particles	
Air connecting parts	from page 102
For the secure connection of the air cleaner to the engine or compressor	
Service switches / indicator	from page 108
Provide an electrical indication when a filter service is required	
Service indicators	from page 112
Indicate via a display when a filter service is required	

System accessories for air cleaners

Rain caps – Design A

In order to effectively prevent ingress of rain, snow, spray water etc. MANN+HUMMEL recommends equipping the air cleaner with a rain cap.

Since this also protects the air cleaner against coarse contaminant particles, the main element is less exposed to damage and this extends the service interval.

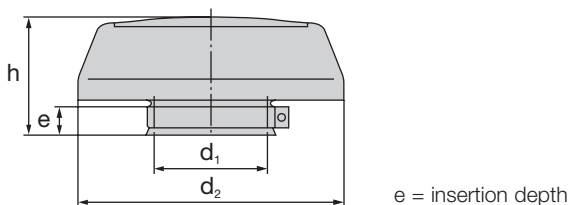

Order no.	Suitable for			Dimensions in mm (<i>Dimensions in inches</i>)				Weigh [kg]
	EUROPICLON	NLG	ENTARON XD	d ₁	d ₂	e	h	
39 014 67 910 ¹⁾	45 050 ...	–	–	45 (1.77)	150 (5.91)	22 (0.87)	63 (2.48)	0.11
39 020 67 910 ¹⁾	45 100 ...	–	–	54 (2.13)	150 (5.91)	22 (0.87)	63 (2.48)	0.11
39 028 67 910 ¹⁾	45 200 ...	–	–	62 (2.44)	150 (5.91)	22 (0.87)	63 (2.48)	0.11
39 040 67 910 ¹⁾	45 300 ...	–	–	68 (2.68)	200 (7.87)	30 (1.18)	85 (3.35)	0.23
39 056 67 910 ¹⁾	45 400 ...	–	–	82 (3.23)	200 (7.87)	30 (1.18)	85 (3.35)	0.23
39 080 67 910 ¹⁾	45 500 ...	–	–	102 (4.02)	270 (10.63)	40 (1.57)	115 (4.53)	0.44
39 100 67 910 ¹⁾	45 600 ...	–	–	110 (4.33)	270 (10.63)	40 (1.57)	115 (4.53)	0.44
39 160 67 910 ¹⁾	45 700 ...	NLG 15 - ...	XD 14/17	132 (5.20)	360 (14.17)	50 (1.97)	150 (5.91)	0.90
39 190 67 910 ¹⁾	45 800 ...	NLG 21 - ...	XD 21	150 (5.91)	360 (14.17)	50 (1.97)	150 (5.91)	0.90
39 220 67 910 ¹⁾	–	NLG 28 - ...	XD 28	180 (7.09)	405 (15.94)	33 (1.30)	128 (5.04)	0.95
39 370 67 910 ¹⁾	–	NLG 37 - ...	–	210 (8.27)	535 (21.06)	42 (1.56)	126 (4.96)	1.80

¹⁾ Plastic model, Cr(VI)-free

System accessories for air cleaners

Rain caps – Design B

The rain caps are simply pushed on to the dirty air connection of the air cleaner or onto the air intake of the dirty air pipe and then fastened using the tightening strap supplied.

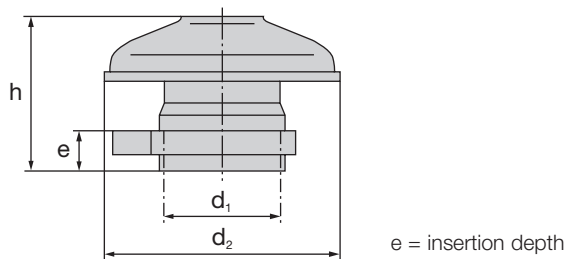

Order no.	Suitable for			Dimensions in mm (<i>Dimensions in inches</i>)				Weigh [kg]
	EUROPICLON	NLG	ENTARON XD	d ₁	d ₂	e	h	
39 014 67 900 ¹⁾	45 050 ...	–	–	45 (1.77)	92 (3.62)	22 (0.87)	53 (2.09)	0.07
39 020 67 900 ¹⁾	45 100 ...	–	–	54 (2.13)	110 (4.33)	22 (0.87)	53 (2.09)	0.08
39 028 67 900 ¹⁾	45 200 ...	–	–	62 (2.44)	124 (4.88)	22 (0.87)	56 (2.20)	0.11
39 040 67 900 ¹⁾	45 300 ...	–	–	68 (2.68)	145 (5.71)	22 (0.87)	63 (2.48)	0.12
39 056 67 900 ¹⁾	45 400 ...	–	–	82 (3.23)	172 (6.77)	22 (0.87)	64 (2.52)	0.15
39 080 67 900 ¹⁾	45 500 ...	–	–	102 (4.02)	203 (7.99)	35 (1.38)	90 (3.54)	0.18

¹⁾ Plastic model, Cr(VI)-free

System accessories for air cleaners

Air connecting parts – Elbow pipes

90° elbows

Operating temperature: -40 °C to +100 °C

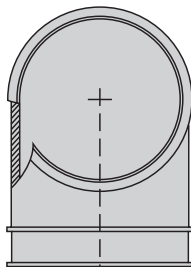
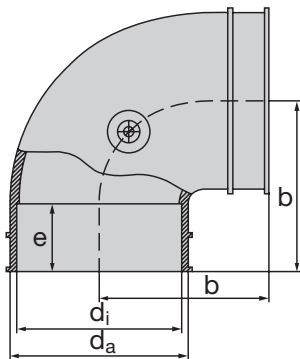

Fig. 1

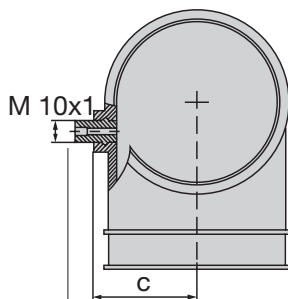

Fig. 2

Connection for service indicator / service switch

Order no.	Fig.	Dimensions in mm (<i>Dimensions in inches</i>)					Connection for
		b	c	d _i	d _a	e	
39 100 25 999	1	57	–	50	55	25	–
39 100 25 979	2	(2.24)	33 (1.30)	(1.97)	(2.17)	(0.98)	M 10x1
39 200 25 999	1	62	–	60	65	25	–
39 200 25 979	2	(2.44)	38 (1.50)	(2.36)	(2.56)	(0.98)	M 10x1
39 300 25 999	1	72	–	70	75	28	–
39 300 25 979	2	(2.83)	43 (1.69)	(2.76)	(2.95)	(1.10)	M 10x1
39 400 25 999	1	77	–	80	85	30	–
39 400 25 979	2	(3.03)	48 (1.89)	(3.15)	(3.35)	(1.18)	M 10x1
39 215 25 999	1	77	–	89	94	25	–
		(3.03)		(3.5)	(3.7)	(0.99)	
39 500 25 999	1	92	–	100	105	35	–
39 500 25 979	2	(3.62)	58 (2.28)	(3.94)	(4.13)	(1.38)	M 10x1
39 600 25 999	1	89	–	110	119	27	–
39 600 25 979	2	(3.50)	63 (2.48)	(4.33)	(4.69)	(1.06)	M 10x1
39 700 25 999	1	98.5	–	130	135	27	–
39 700 25 979	2	(3.88)	75 (2.95)	(5.12)	(5.32)	(1.06)	M 10x1
39 800 25 999	1	108.5	–	150	155	27	–
39 800 25 979	2	(4.27)	83 (3.27)	(5.91)	(6.10)	(1.06)	M 10x1
39 930 25 999	1	170	–	180	196	30	–
39 930 25 979	2	(6.69)	98.5 (3.88)	(7.08)	(7.71)	(1.18)	M 10x1

System accessories for air cleaners

Air connecting parts – Connections

Reducer connections

Operating temperature: -40 °C to +100 °C

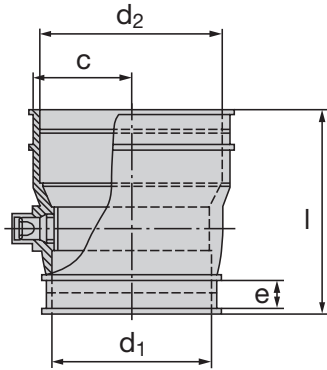

Order no.	Dimensions in mm (<i>Dimensions in inches</i>)				
	c	d_1	d_2	e	l
39 300 27 949	43 (1.69)	70 (2.76)	80 (3.15)	13.5 (0.53)	89.5 (3.52)
39 300 27 959	43 (1.69)	60 (2.36)	70 (2.76)	13.5 (0.53)	85.5 (3.37)
39 300 27 969	43 (1.69)	50 (1.97)	70 (2.76)	13.5 (0.53)	85.5 (3.37)

Straight connections

Operating temperature: -40 °C to +100 °C

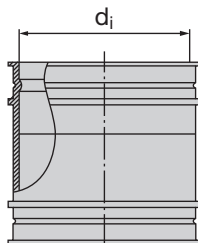

Fig. 1

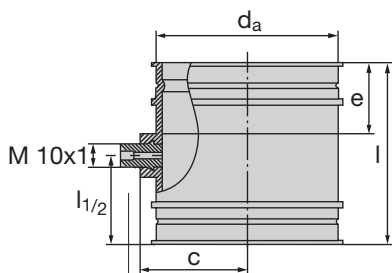

Fig. 2

Order no.	Fig.	Dimensions in mm (<i>Dimensions in inches</i>)					Connection for
		c	d_i	d_a	e	l	
39 100 27 999	1	–	50 (1.97)	55 (2.17)	25 (0.98)	68 (2.68)	–
39 100 27 979	2	33 (1.30)	50 (1.97)	55 (2.17)	25 (0.98)	68 (2.68)	M 10x1
39 200 27 999	1	–	60 (2.36)	65 (2.56)	25 (0.98)	68 (2.68)	–
39 200 27 979	2	38 (1.50)	60 (2.36)	65 (2.56)	25 (0.98)	68 (2.68)	M 10x1
39 300 27 999	1	–	70 (2.76)	75 (2.95)	28 (1.10)	75 (2.95)	–
39 300 27 979	2	43 (1.69)	70 (2.76)	75 (2.95)	28 (1.10)	75 (2.95)	M 10x1
39 400 27 999	1	–	80 (3.15)	85 (3.35)	30 (1.18)	78 (3.07)	–
39 400 27 979	2	48 (1.89)	80 (3.15)	85 (3.35)	30 (1.18)	78 (3.07)	M 10x1
39 215 27 999	1	–	89 (3.5)	94 (3.7)	25 (0.98)	70 (2.76)	–
39 500 27 999	1	–	100 (3.94)	105 (4.13)	35 (1.38)	88 (3.46)	–
39 500 27 979	2	58 (2.28)	100 (3.94)	105 (4.13)	35 (1.38)	88 (3.46)	M 10x1
39 600 27 999	1	–	110 (4.33)	119 (4.69)	27 (1.06)	72 (2.83)	–
39 600 27 979	2	63 (2.48)	110 (4.33)	119 (4.69)	27 (1.06)	72 (2.83)	M 10x1
39 700 27 999	1	–	130 (5.12)	135 (5.32)	27 (1.06)	72 (2.83)	–
39 700 27 979	2	75 (2.95)	130 (5.12)	135 (5.32)	27 (1.06)	72 (2.83)	M 10x1
39 800 27 999	1	–	150 (5.91)	155 (6.10)	27 (1.06)	72 (2.83)	–
39 800 27 979	2	83 (3.28)	150 (5.91)	155 (6.10)	27 (1.06)	72 (2.83)	M 10x1
39 930 27 999	1	–	180 (7.09)	195 (7.68)	45 (1.77)	140 (5.51)	–
39 930 27 979	2	109.5 (4.31)	180 (7.09)	195 (7.68)	45 (1.77)	140 (5.51)	M 10x1

System accessories for air cleaners

Air connecting parts – Straight couplings in rubber

Straight couplings

Material: rubber (NBR. 60±5 Shore)

with fabric insert

Operating temperature: -30 °C to +100 °C

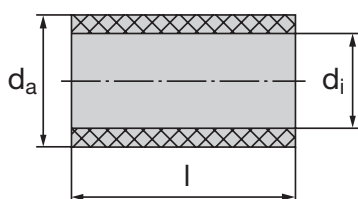

Order no.	Dimensions in mm (<i>Dimensions in inches</i>)		
	d_i	d_a	l
39 000 27 198	60 (2.36)	74 (2.91)	150 (5.91)
39 000 27 197	70 (2.76)	84 (3.31)	150 (5.91)
39 000 27 252	70 (2.76)	84 (3.31)	80 (3.15)
39 000 27 196	80 (3.15)	96 (3.78)	150 (5.91)
39 000 27 195	90 (3.54)	106 (4.17)	150 (5.91)
39 000 27 104	100 (3.94)	116 (4.57)	100 (3.94)
39 000 27 194	100 (3.94)	118 (4.65)	150 (5.91)
39 000 27 193	110 (4.33)	126 (4.96)	150 (5.91)
39 000 27 359	110 (4.33)	128 (5.04)	75 (2.95)

Order no.	Dimensions in mm (<i>Dimensions in inches</i>)		
	d_i	d_a	l
39 000 27 188	130 (5.12)	148 (5.83)	100 (3.94)
39 000 27 192	130 (5.12)	148 (5.83)	150 (5.91)
39 000 27 297	130 (5.12)	148 (5.83)	65 (2.56)
39 000 27 183	150 (5.91)	166 (6.54)	150 (5.91)
39 223 27 111	150 (5.91)	168 (6.61)	100 (3.94)
39 000 27 182	180 (7.09)	198 (7.80)	150 (5.91)
39 000 27 345	200 (7.87)	218 (8.58)	200 (7.87)
39 000 27 306	210 (8.27)	228 (8.98)	200 (7.87)

System accessories for air cleaners

Air connecting parts – Elbow pipes in rubber and Couplings in metal

90° elbows

Material: rubber
(NBR, 60±5 Shore)

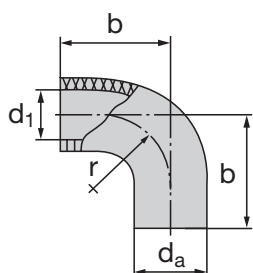

Fig. 1

90° elbows

with fabric insert

Operating temperature:
-25 °C to +100 °C

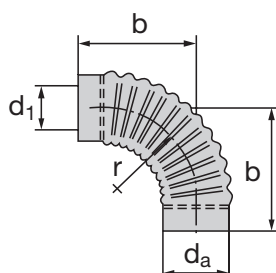

Fig. 2

Couplings

(black painted metal)

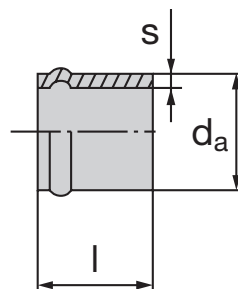

Fig. 3

Order no.	Fig.	Dimensions in mm (<i>Dimensions in inches</i>)			
		b	d ₁	d _a	r
39 000 25 280	1	115 (4.53)	52 (2.05)	60 (2.36)	75 (2.95)
39 000 25 264	1	115 (4.53)	60 (2.36)	68 (2.68)	75 (2.95)
39 000 25 263	1	140 (5.51)	70 (2.76)	79 (3.11)	90 (3.54)
39 000 25 262	1	140 (5.51)	80 (3.15)	90 (3.54)	95 (3.74)
39 000 25 258	2	205 (8.07)	100 (3.94)	110 (4.33)	155 (6.10)
39 000 25 265	2	215 (8.46)	110 (4.33)	120 (4.72)	165 (6.50)
39 000 25 266	2	265 (10.43)	130 (5.12)	140 (5.51)	210 (8.27)
39 000 25 267	2	300 (11.81)	150 (5.91)	160 (6.30)	245 (9.65)
39 000 25 270	2	355 (13.98)	200 (7.87)	210 (8.27)	300 (11.81)

Order no.	Fig.	Dimensions in mm (<i>Dimensions in inches</i>)		
		d _a	l	s
39 000 25 177	3	52 (2.05)	50 (1.97)	0.75 (0.03)
39 000 25 167	3	62 (2.44)	65 (2.56)	1.0 (0.04)
39 000 25 164	3	70 (2.76)	50 (1.97)	1.0 (0.04)
39 000 25 168	3	82 (3.23)	50 (1.97)	1.0 (0.04)
39 000 25 165	3	92 (3.62)	50 (1.97)	1.0 (0.04)
39 000 25 175	3	102 (4.02)	50 (1.97)	1.0 (0.04)
39 000 25 176	3	110 (4.33)	50 (1.97)	1.0 (0.04)
39 000 25 174	3	132 (5.20)	50 (1.97)	1.0 (0.04)
39 000 25 184	3	150 (5.91)	90 (3.54)	1.0 (0.04)
39 000 25 185	3	180 (7.09)	90 (3.54)	1.0 (0.04)

System accessories for air cleaners

Connection pipes – Couplings in metal

Intermediate pipe (black painted metal)
only for dirty air intake

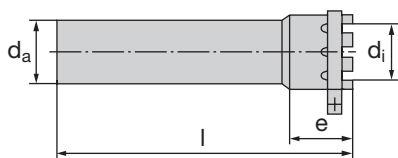

Fig. 4

Order no.	Fig.	Dimensions in mm (<i>Dimensions in inches</i>)			
		d_i	d_a	e	l
31 056 25 821	4	82.2 (3.24)	82 (3.23)	80 (3.15)	245 (9.65)
31 080 25 731	4	102.2 (4.02)	102 (4.02)	80 (3.15)	250 (9.84)
39 100 25 991	4	110.2 (4.34)	110 (4.33)	110 (4.33)	200 (7.87)
31 160 25 771	4	132.2 (5.20)	132 (5.20)	110 (4.33)	400 (15.75)

Pipes (black painted metal)

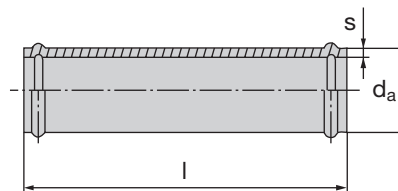

Fig. 5

Order no.	Fig.	Dimensions in mm (<i>Dimensions in inches</i>)		
		d_a	l	s
39 000 25 172	5	42 (1.65)	500 (19.69)	0.75 (0.03)
39 000 25 173	5	82 (3.23)	500 (19.69)	0.75 (0.03)
39 000 25 158	5	92 (3.62)	500 (19.69)	0.75 (0.03)
39 000 25 183	5	102 (4.02)	500 (19.69)	0.75 (0.03)
39 000 25 166	5	110 (4.33)	500 (19.69)	0.75 (0.03)
39 000 25 157	5	132 (5.20)	500 (19.69)	0.75 (0.03)
39 000 25 155	5	150 (5.91)	500 (19.69)	0.75 (0.03)



System accessories for air cleaners

Air connecting parts – Elbow pipes in metal

Metal elbow pipes (black painted metal)

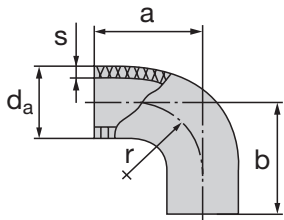

Fig. 1

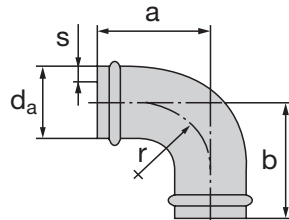
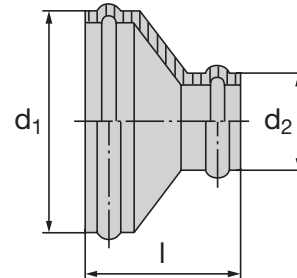

Fig. 2

Order no.	Fig.	Dimensions in mm (<i>Dimensions in inches</i>)				
		a	b	d _a	r	s
39 000 25 188	1	60 (2.36)	60 (2.36)	52 (2.05)	40 (1.57)	0.75 (0.03)
31 034 25 442	1	95 (3.74)	95 (3.74)	62 (2.44)	60 (2.36)	0.75 (0.03)
39 000 25 152	1	70 (2.76)	70 (2.76)	70 (2.76)	60 (2.36)	1.0 (0.04)
39 000 25 207	2	100 (3.94)	100 (3.94)	70 (2.76)	60 (2.36)	1.0 (0.04)
39 000 25 956	2	110 (4.33)	110 (4.33)	80 (3.15)	55 (2.17)	1.0 (0.04)
39 000 25 148	1	61 (2.40)	61 (2.40)	82 (3.23)	55 (2.17)	1.0 (0.04)
39 000 25 153	1	80 (3.15)	67 (2.64)	90 (3.54)	60 (2.36)	1.0 (0.04)
39 000 25 273	1	80 (3.15)	80 (3.15)	100 (3.94)	65 (2.56)	1.0 (0.04)
39 000 25 124	2	110 (4.33)	110 (4.33)	100 (3.94)	65 (2.56)	1.0 (0.04)
39 000 25 146	1	90 (3.54)	90 (3.54)	110 (4.33)	85 (3.35)	1.0 (0.04)
39 000 25 192	2	110 (4.33)	110 (4.33)	110 (4.33)	85 (3.35)	1.0 (0.04)
39 000 25 198	2	125 (4.92)	125 (4.92)	110 (4.33)	85 (3.35)	1.0 (0.04)
39 000 25 147	1	120 (4.72)	120 (4.72)	130 (5.12)	95 (3.74)	1.0 (0.04)
39 000 25 224	2	140 (5.51)	140 (5.51)	130 (5.12)	95 (3.74)	1.0 (0.04)
39 000 25 142	1	180 (7.09)	180 (7.09)	150 (5.91)	110 (4.33)	1.0 (0.04)
39 000 25 333	2	180 (7.09)	180 (7.09)	150 (5.91)	110 (4.33)	1.0 (0.04)

Adapter pieces (black painted metal)



Order no.	Dimensions in mm (<i>Dimensions in inches</i>)		
	d ₁	d ₂	l
39 000 25 621	70 (2.76)	40 (1.57)	65 (2.56)
39 000 25 622	70 (2.76)	60 (2.36)	56 (2.20)
39 000 25 631	80 (3.15)	50 (1.97)	65 (2.56)
39 000 25 431	82 (3.23)	70 (2.76)	56 (2.20)
39 000 25 461	100 (3.94)	70 (2.76)	75 (2.95)
31 080 25 511	102 (4.02)	80 (3.15)	76 (2.99)
39 000 25 295	110 (4.33)	80 (3.15)	75 (2.95)
39 000 25 193	110 (4.33)	100 (3.94)	70 (2.76)
39 000 25 105	132 (5.20)	102 (4.02)	71 (2.80)
39 000 25 253	132 (5.20)	110 (4.33)	76 (2.99)
39 000 25 325	150 (5.91)	130 (5.12)	86 (3.39)
39 000 25 145	180 (7.09)	150 (5.91)	95 (3.74)
39 000 25 327	200 (7.87)	150 (5.91)	105 (4.13)

System accessories for air cleaners

New Electronic Service Indicator

The new electronic service indicator from MANN+HUMMEL indicates the optimal point for servicing of your air filter system and hence reduces operational cost, risk and down time.

During operation the indicator exactly displays the continuous increase in differential pressure in air cleaners in combustion engines and compressors. The electronic service indicator offers advantages for machine operators. It is easier to schedule the servicing – leading to lower running costs. The service indicator is suitable for differential pressures from 0 to 100 mbar and can be combined with the following air cleaner series: IQORON, IQORON-V, IQORON-S, ENTARON XD, EUROPICLON, NLG.

An adapter makes the indicator compatible to all air cleaners for combustion engines available on the market.



Order no.	Fig.	
39 000 70 920	1	Service indicator assy, packed (Kit including display, pressure sensor, cable harness, manual), programmable for 50/65/80 mbar
39 000 70 910	2	Pressure sensor assy, packed, with connection jack AMPSEAL 16 (Output voltage has to be evaluated with additional interface, e.g. using the on-board electronic system)
26 013 98 100	3	Cable harness assy, packed, suitable for connection jack AMPSEAL 16, with wire leads

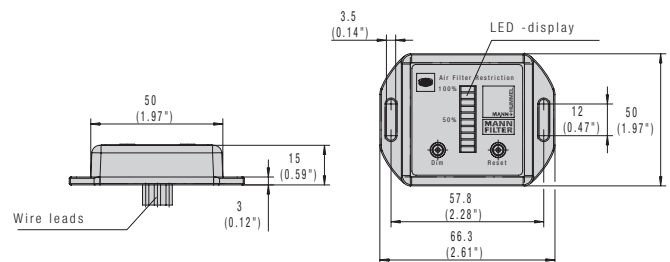

Fig. 1 Protection class: IP50

Technical Specification

Measurement Type:	Vacuum or Pressure (Reference to atmosphere)
Operational Pressure Range:	0 - 100 mbar [0 - 10 kPa]
Media:	Air
Supply Voltage:	Normal 5 - 30 V DC; Sensor can be powered direct from vehicle up to 30 V DC.
Accuracy:	± 2,5 %
Output Voltage:	0.5 - 4.5 V DC
Over-Voltage Protection:	45 V, Forward Voltage
Reverse Polarity Protection:	36 V, Misconnect 16 V
Operating Temperature:	-40 °C to 125 °C
Storage Temperature:	-40 °C to 125 °C
Vibration Envelope:	10 - 2000 Hz at 10 g
Mounting Connection:	M10x1 female thread fits all MANN+HUMMEL air cleaners (adapter for any other air cleaners on request)

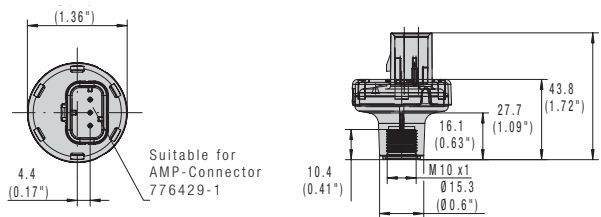

Fig. 2 Protection class: IP66

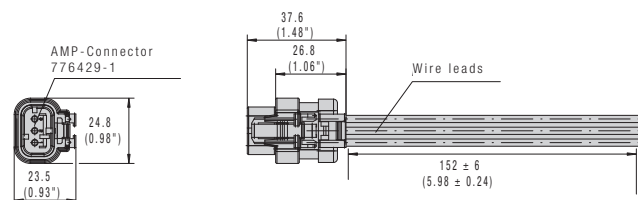

Fig. 3 Protection class: IP66

System accessories for air cleaners

Service switches for electrical monitoring of the level of accumulated dirt

The electrical service switch monitors the level of accumulated dirt in the air cleaner and sends an electrical signal when maintenance is required.

This enables constant supervision of the state of the air cleaner and maintenance only takes place when it is really necessary.

This removes potential damage to equipment which may occur through frequent and careless maintenance actions.



Technical instructions

Thanks to the completely insulated and fully enclosed contact insert, the switch is insensitive to dust or humidity. The system is not mechanical but pressure-dependent so that possible tolerances of the components do not affect the accuracy of the switch. The heart of the system is a kick-over spring that makes readjustment of the switching point unnecessary. The spring contacts are not affected by contact erosion.

As a result of the hysteresis between the points for switching and switching back, contact fluttering is reduced to a minimum. The service switch should not be fitted in a hanging position so as to prevent ingress of any condensed water into the air pipe.

Models

MANN+HUMMEL service switches are available with a number of different connection threads and plug connectors versions (Adapter from M10x1 to 1/8"-27 NPT).

Specifications

- Material: polyamide 6 GF 30
- Permissible operating temperature: -30 °C to + 120 °C
- Switching pressure (negative pressure): 35 mbar to 80 mbar (3.5 kPa to 8.0 kPa)
- Max. switching capacity: 6 W/24 V DC (ohmnic load, $U_{\max} = 24 \text{ V}$, $I_{\max} = 0.25 \text{ A}$)

System accessories for air cleaners

Service switches with connection for flat plug (Protection class: IP21)



Service switch internal thread M 10x1

Order no.	switches at gauge pressure	
	[mbar]	[kPa]
39 035 70 902	35±3	3.5±0.3
39 050 70 902	50±3	5.0±0.3
39 055 70 902	55±3	5.5±0.3
39 060 70 902	60±3	6.0±0.3
39 065 70 902	65±3	6.5±0.3
39 070 70 902	70±4	7.0±0.4
39 080 70 902	80±4	8.0±0.4

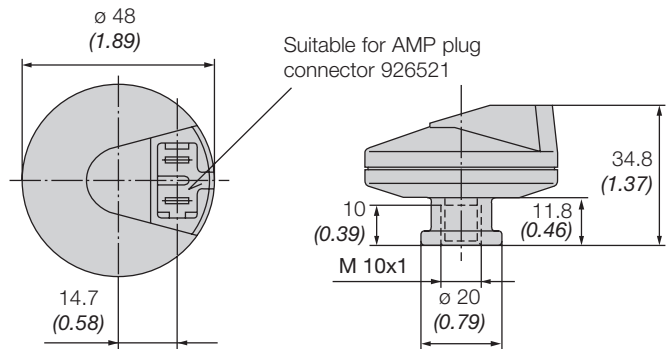

Service switch external thread M 10x1

Order no.	switches at gauge pressure	
	[mbar]	[kPa]
39 035 70 952	35±3	3.5±0.3
39 050 70 952	50±3	5.0±0.3
39 055 70 952	55±3	5.5±0.3
39 060 70 952	60±3	6.0±0.3
39 065 70 952	65±3	6.5±0.3
39 070 70 952	70±4	7.0±0.4
39 080 70 952	80±4	8.0±0.4

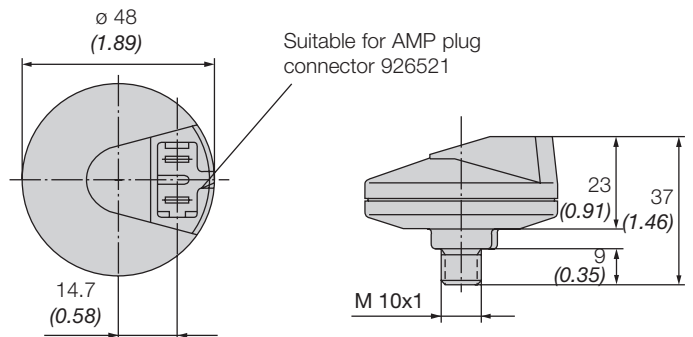

Service switch external thread 1/8"-27 NPT

Order no.	switches at gauge pressure	
	[mbar]	[kPa]
39 035 70 962	35±3	3.5±0.3
39 050 70 962	50±3	5.0±0.3
39 055 70 962	55±3	5.5±0.3
39 060 70 962	60±3	6.0±0.3
39 065 70 962	65±3	6.5±0.3
39 080 70 962	80±4	8.0±0.4

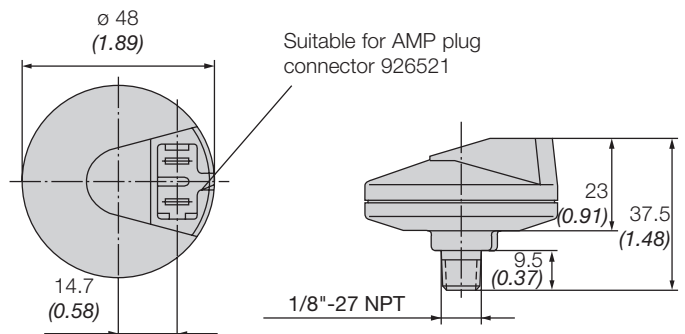

System accessories for air cleaners

Service switches for water-tight electrical connections (Protection class: IP65)

Service switch internal thread M 10x1

Order no.	switches at gauge pressure	
	[mbar]	[kPa]
39 035 70 702	35±3	3.5±0.3
39 050 70 702	50±3	5.0±0.3
39 055 70 702	55±3	5.5±0.3
39 060 70 702	60±3	6.0±0.3
39 065 70 702	65±3	6.5±0.3
39 070 70 702	70±4	7.0±0.4
39 080 70 702	80±4	8.0±0.4

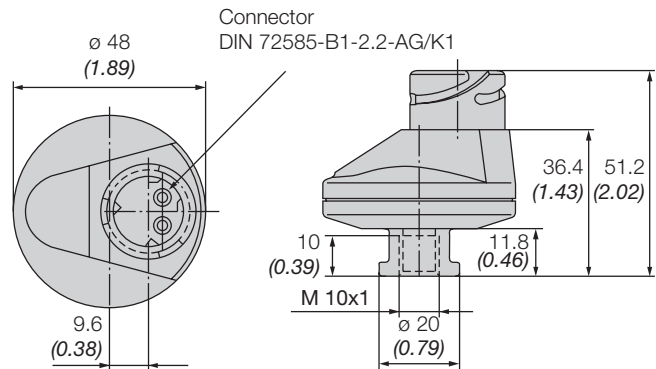

Service switch internal thread M 10x1

Order no.	switches at gauge pressure	
	[mbar]	[kPa]
39 035 70 802	35±3	3.5±0.3
39 050 70 802	50±3	5.0±0.3
39 055 70 802	55±3	5.5±0.3
39 060 70 802	60±3	6.0±0.3
39 065 70 802	65±3	6.5±0.3
39 070 70 802	70±4	7.0±0.4
39 080 70 802	80±4	8.0±0.4

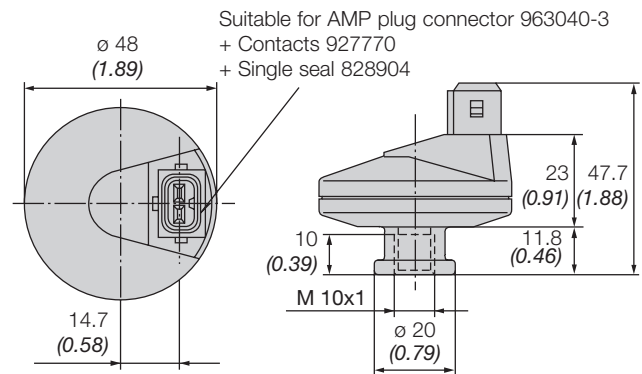

Service switch external thread M 10x1

Order no.	switches at gauge pressure	
	[mbar]	[kPa]
39 035 70 852	35±3	3.5±0.3
39 050 70 852	50±3	5.0±0.3
39 055 70 852	55±3	5.5±0.3
39 060 70 852	60±3	6.0±0.3
39 065 70 852	65±3	6.5±0.3
39 080 70 852	80±4	8.0±0.4

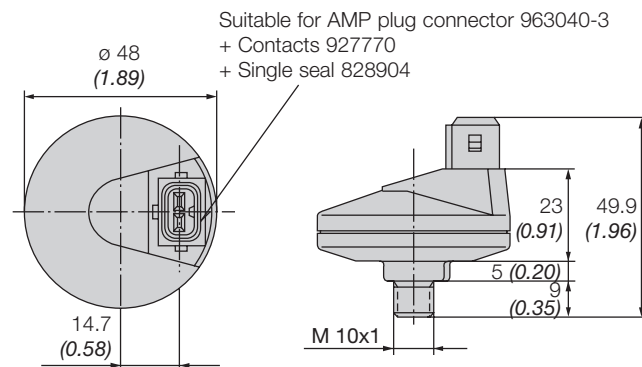

Service switch external thread 1/8"-27 NPT

Order no.	switches at gauge pressure	
	[mbar]	[kPa]
39 035 70 862	35±3	3.5±0.3
39 050 70 862	50±3	5.0±0.3
39 055 70 862	55±3	5.5±0.3
39 060 70 862	60±3	6.0±0.3
39 065 70 862	65±3	6.5±0.3
39 080 70 862	80±4	8.0±0.4

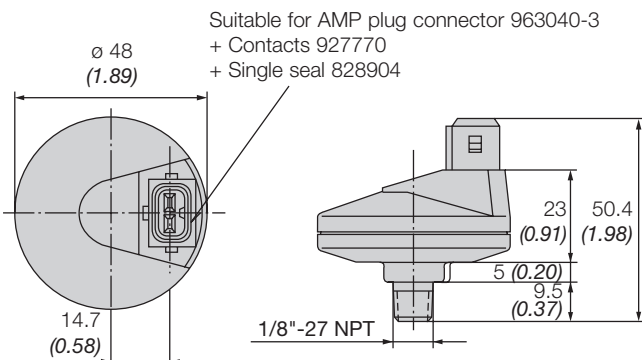

System accessories for air cleaners

Service indicators for level of dirt accumulation

The **MANN+HUMMEL** service indicator allows you to read the current level of dirt accumulation in the air cleaner, even when the engine is not in operation.

The yellow indicating piston catches on a scale of 12 snap-in positions. In the triangular display, the remaining service life of the filter is displayed, in relation to the increased clogging of the filter element.

The service indicator is insensitive to the intake air pulsations of the engine, excluding the possibility of a false indication. Maintenance is necessary when the yellow piston reaches the red zone. After maintenance has been carried out, the indicator level is readjusted to “zero” by pressing the reset button.



Specifications

- Material: PC
 - Permissible operating temperature:
-30 °C to +100 °C
 - Switching pressure (negative pressure):
35 mbar to 80 mbar
(3.5 kPa to 8 kPa)
- * readable in vertical position

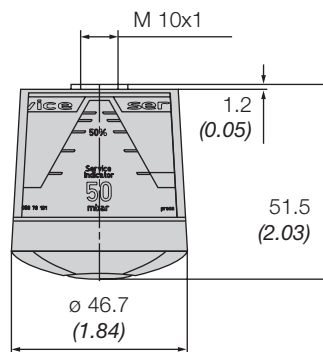

Order no.	snaps into place at gauge pressure	
	[mbar]	[kPa]
39 035 70 911	35±3	3.5±0.3
39 050 70 911	50±4	5.0±0.4
39 050 70 931*	50±4	5.0±0.4
39 060 70 911	60±4	6.0±0.4
39 065 70 911	65±5	6.5±0.5
39 080 70 911	80±5	8.0±0.5
39 080 70 931*	80±5	8.0±0.5

Service indicators with 90° flange

The 90° connecting flange allows nearly any fitting position. The red indicating piston snaps into position upon reaching the maximum value possible, signalling that maintenance is needed. After maintenance has been carried out, the indicating piston is readjusted to the start position by pressing the reset button.

Specifications

- Material: PA
- Permissible operating temperature:
-40 °C to +100 °C
- Switching pressure (negative pressure):
35 mbar to 80 mbar
(3.5 kPa to 8 kPa)

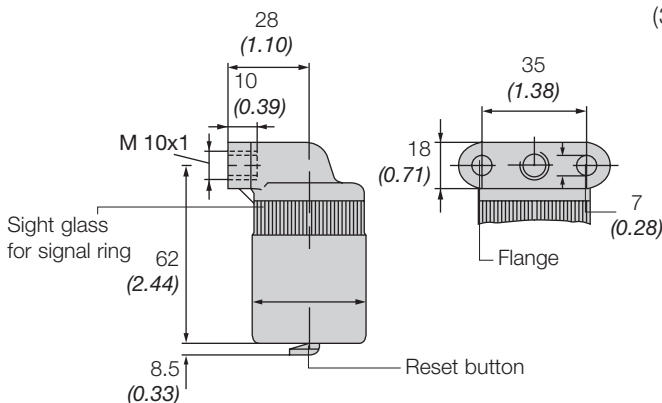

Order no.	snaps into place at gauge pressure	
	[mbar]	[kPa]
39 000 62 924	35±3	3.5±0.3
39 000 62 925	50±6	5.0±0.6
39 000 62 926	65±7	6.5±0.7
39 000 62 927	80±8	8.0±0.8

Technical appendix

Filter glossary, Conversion tables,
Request form, Further information



Glossary of terms

For air cleaners

Raw air, FAD (free air delivery)

Nominal flow V [m³/min]

Describes the nominal point of an air cleaner. For compressors the volume flow sucked in via the air cleaner is described as FAD.

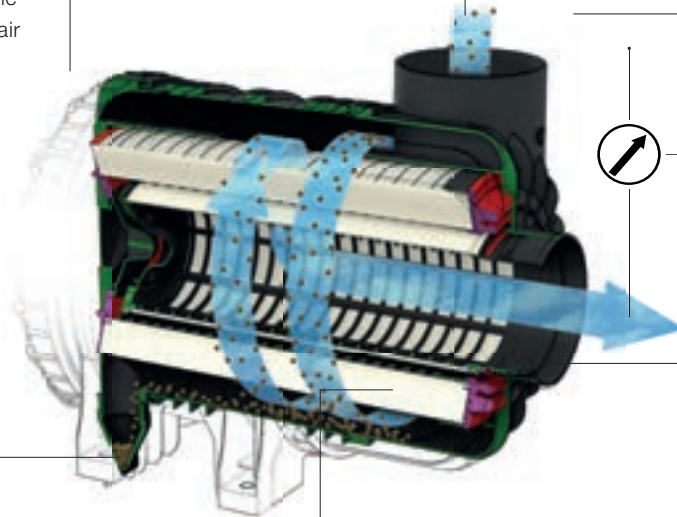

Flow resistance Δp [mbar]

Measured variable acc. to ISO 5011 for the pressure drop of a filter. The catalogue always lists the negative pressure after the filter.

Dust discharge valve

Valve on the housing of two-stage air cleaners which discharges the separated dust from the air cleaner housing.

Main element

An air filter element made from a pleated filter medium through which the filtration takes place. The filter surface area defines the life of the filter.

Secondary element

An additional air filter element fitted downstream of the main element which prevents ingress of dust into the clean air pipe during maintenance work or when the main element is defective.

Service life [h]

Life of filter determined in the field before the filter needs servicing.

Laboratory service life [h]

The time measured under laboratory conditions (ISO 5011) that an air filter with air flowing through it and loaded with dust will reach a defined flow resistance. The test dust, dust concentration and volume flow must be defined.

Laboratory dust capacity [g]

The measured quantity of a defined test dust which is added to a filter under laboratory conditions until the service point is reached.

Separation efficiency η [%]

The most important task of an air cleaner is to provide adequate protection for the application in use (e.g. engine, compressor, etc.) under all conceivable operating conditions. The separation efficiency of the filter therefore has to be sufficiently high to meet this requirement. The measurement of the separation efficiency is defined by ISO 5011. A dosing device is used to add dust to the filter with a defined particle size spectrum and concentration. The filter separates by far the largest part of this dust. The separation efficiency of the filter is given by the ratio of the separated dust mass to the dosed dust mass. The separation efficiency of dry air cleaners is usually above 99.95 %.

Preseparator

MANN+HUMMEL two-stage filters have an integrated preseparator (cyclone effect through tangential inflow with EUROPICLON, NLG Piclon or ENTARON XD) or cyclone cells (IQORON-V). The separation efficiency of the whole filter is determined in exactly the same way as for a single stage filter. A higher preseparation efficiency correspondingly reduces the dust concentration which enters the main filter element and therefore a higher preseparation efficiency serves to lengthen the service life of the filter.

Glossary of terms

For air cleaners



Visual service indicator

Mounted device which visually indicates when the permitted differential pressure (clean air port to ambient environment) has been reached (indicating filter maintenance is required).



Electrical service switch

A fixture which displays the reaching of the permissible differential pressure (clean port to the environment) through closing of an electrical contact (filter maintenance). This enables signal processing.



Electrical service indicator

Indicates the continual increase in differential pressure of the air cleaner during operation. The differential pressure is displayed on the service indicator and therefore enables the planning of the filter maintenance work.



Single stage filter



Two-stage filter

Tangential inlet

The tangential inlet creates a cyclone effect and therefore preseparation.

Single and two-stage filters

Single stage filters are equipped with main separation and are the ideal solution for operating conditions with low dust levels. For conditions with medium to high dust levels, however, a two-stage filter is the best choice as this type of filter has additional preseparation. The performance of the preseparator reduces the burden on the main filter element and lengthens its life.

Dust discharge

This discharges the separated dust from the filter.

Glossary of terms

Oil filters

Nominal flow V [m^3/min]

The nominal flow is closely connected to the geometrical filter design data (nominal size of connection, filter fineness) and the physical characteristics of the liquid to be filtered (density, viscosity).

Dynamic viscosity η [$Pa \cdot s$]

The dynamic viscosity is a measure of the internal friction of the medium to be filtered.

Kinematic viscosity ν [St]

The kinematic viscosity represents the dynamic viscosity of the medium per unit density.

Bypass valve

Valve which opens at a certain opening pressure to allow an oil flow to bypass the filter medium. The valve prevents an impermissible pressure level in the system and over the filter medium (e.g. with pressure surges, when starting with cold oil or also if the filter medium is clogged).

Opening pressure [bar]

The pressure difference over the filter element where the bypass valve opens. The valve opens proportionally to the pressure difference. The usual values for compressors are between 1.5 and 3.5 bar.

Separation efficiency η [%]

The ratio of the retained dirt to the added dirt.

β_x value

The beta value for a certain particle size X is the relationship of the number of these particles before the filter to the number of particles after the filter. The conversion to the separation efficiency is as follows: $\eta = (1 - 1/\beta) \times 100$.

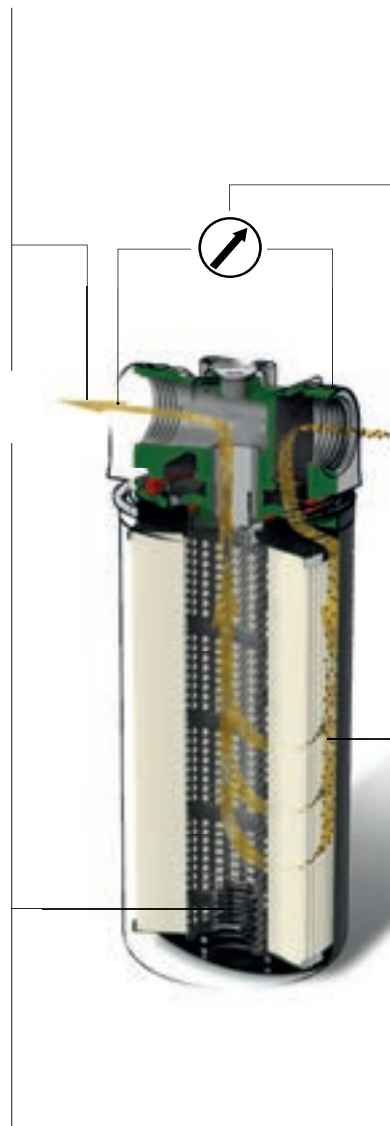

Flow resistance Δp [mbar]

Measured variable for the pressure drop of a filter.

Multipass test for oil filters

Test measured acc. to ISO 4548-12 or ISO 16 889. A defined dust is added until the defined differential pressure over the filter element has been reached. The result is the separation efficiency per particle size over time.

Operating pressure [bar]

The pressure the filter was designed to work with and with which it can be continuously operated.

Collapse pressure [bar]

The pressure at which the filter fails due to differential pressure over the filter which is too high.

Bursting pressure [bar]

The pressure at which the filter structure is expected to fail.

Absolute separation efficiency

In a single flow through the filter 99 % of a given particle size are separated. Example: 15 μm absolute: 99 % particles of the size 15 μm are separated in a single flow through the filter ($\Rightarrow \beta_{15}=100$).

Nominal separation efficiency

In a single flow through the filter 50 % of a given particle size are separated. Example: 50 % particles of the size 15 μm are separated in a single flow through the filter ($\Rightarrow \beta_{15}=2$).

Glossary of terms

Air/oil separators

Nominal flow / FAD V [m³/min]

FAD (free air delivery) is used as a volume flow variable in compressors. After the compression the corresponding operating parameters (pressure and temperature) must also be given.

Preseparation

Adequate preseparation is essential for the function of the separator. In many compressors this is realised via the formation of a swirl with the aid of a tangential inlet and a shield. The oil content after preseparation should not exceed 5 g/m³. The use of other types of preseparation is possible in principle provided the requirements are met.

Shield

The shield is a hollow cylinder located concentrically between the inlet port and the air/oil separator of the pressure reservoir.

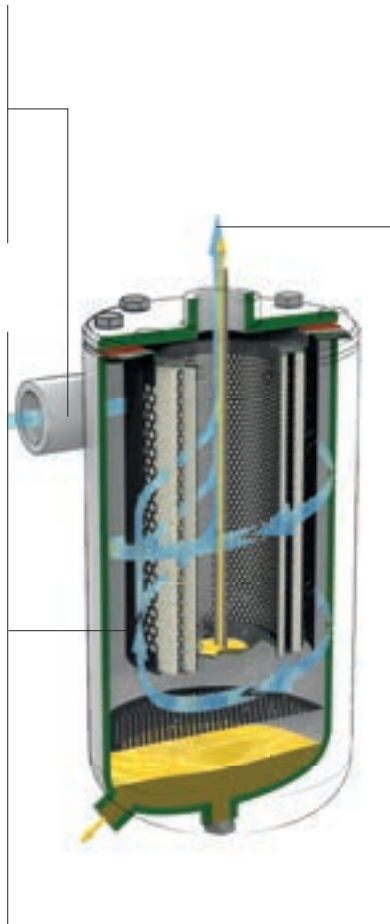

Flange seals

Flange seals are a critical area with regard to electrical conductivity. These can act as insulators. Here care must be taken that an electrical contact to the pressure reservoir and from there to the electrical system exists. This can be made with the use of a metallic stack in the seals or through electrically conducting seals.

Clean air

The air flow which has already passed the separator is called clean air.

Residual oil content [mg/m³]

The clean air may have a residual oil content of approx. 3 mg/m³.

Electrical conductivity [S, 1/Ω]

On a MANN+HUMMEL air/oil separator all the metallic parts have the same electric potential. As a result electrostatic charging through air friction is prevented and discharged.

Glossary of terms

Spin-on air/oil separators (thread from above)

Flow resistance Δp [mbar]

Measured variable for the pressure drop of a filter. The MANN+HUMMEL series StarBox in particular has a significantly low pressure drop compared to a conventional spin-on air/oil separator.

Nominal flow / FAD V [m³/min]

FAD (free air delivery) is used as a volume flow variable in compressors. After the compression the corresponding operating parameters (pressure and temperature) must also be given.

Operating pressure [bar]

The pressure the filter was designed to work with and with which it can be continuously operated.

Collapse pressure [bar]

The pressure at which the filter fails due to differential pressure over the filter which is too high.

Bursting pressure [bar]

The pressure at which the filter structure is expected to fail.

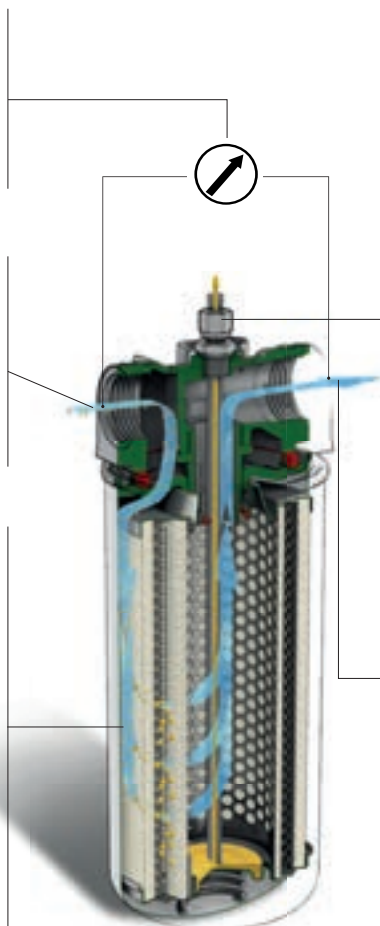

Scavenge line

The scavenge line transports the separated oil back to the compressor oil circuit. It is connected to the suction side of the compressor screw. The scavenge line has to be dimensioned to be large enough as clogging or a size which is too small can impair the function of the separator.

Clean air

The air flow which has already passed the separator is called clean air.

Residual oil content [mg/m³]

The clean air may have a residual oil content of approx. 3 mg/m³. The MANN+HUMMEL series StarBox has a considerably lower value.

Glossary of terms

Spin-on air/oil separators (thread on the underside)

Operating pressure [bar]

The pressure the filter was designed to work with and with which it can be continuously operated.

Collapse pressure [bar]

The pressure at which the filter fails due to differential pressure over the filter which is too high.

Bursting pressure [bar]

The pressure at which the filter structure is expected to fail.

Nominal flow / FAD V [m³/min]

FAD (free air delivery) is used as a volume flow variable in compressors. After the compression the corresponding operating parameters (pressure and temperature) must also be given.

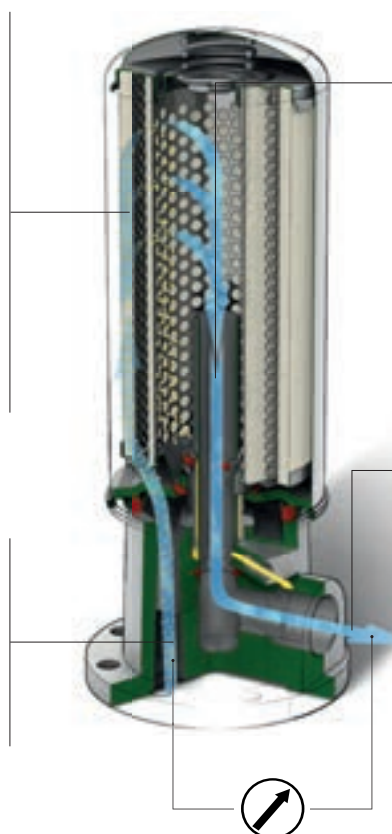

Connector

The connector allows the separated air and the separated oil to be separately removed without the possibility of mixing.

Clean air

The air flow which has already passed the separator is called clean air.

Residual oil content [mg/m³]

The clean air may have a residual oil content of approx. 3 mg/m³. The MANN+HUMMEL series StarBox has a considerably lower value.

Flow resistance Δp [mbar]

Measured variable for the pressure drop of a filter. The MANN+HUMMEL series StarBox in particular has a significantly low pressure drop compared to a conventional spin-on air/oil separator.

Conversion tables

Volume flow

Volume flow m³/min → cfm

1 m ³ /min	=	35.3 cfm
1.7 m ³ /min	=	60.0 cfm
2 m ³ /min	=	70.6 cfm
3 m ³ /min	=	105.9 cfm
4 m ³ /min	=	141.3 cfm
4.5 m ³ /min	=	158.9 cfm
6 m ³ /min	=	211.9 cfm
8 m ³ /min	=	282.5 cfm
10 m ³ /min	=	353.1 cfm
12 m ³ /min	=	423.8 cfm
15 m ³ /min	=	529.7 cfm
18 m ³ /min	=	635.7 cfm
20 m ³ /min	=	706.3 cfm
21 m ³ /min	=	741.6 cfm
24 m ³ /min	=	847.6 cfm
25 m ³ /min	=	882.9 cfm
28 m ³ /min	=	988.8 cfm
32 m ³ /min	=	1130.1 cfm
37 m ³ /min	=	1306.6 cfm
40 m ³ /min	=	1412.6 cfm
42 m ³ /min	=	1483.2 cfm
50 m ³ /min	=	1765.7 cfm
60 m ³ /min	=	2118.9 cfm
80 m ³ /min	=	2825.2 cfm
100 m ³ /min	=	3531.5 cfm

Volume flow cfm → m³/min

25 cfm	=	35.3 m ³ /min
50 cfm	=	1.4 m ³ /min
75 cfm	=	2.1 m ³ /min
100 cfm	=	2.8 m ³ /min
150 cfm	=	4.2 m ³ /min
200 cfm	=	5.7 m ³ /min
250 cfm	=	7.1 m ³ /min
300 cfm	=	8.5 m ³ /min
350 cfm	=	9.9 m ³ /min
400 cfm	=	11.3 m ³ /min
450 cfm	=	12.7 m ³ /min
500 cfm	=	14.2 m ³ /min
550 cfm	=	15.6 m ³ /min
600 cfm	=	17.0 m ³ /min
650 cfm	=	18.4 m ³ /min
700 cfm	=	19.8 m ³ /min
750 cfm	=	21.2 m ³ /min
800 cfm	=	22.7 m ³ /min
850 cfm	=	24.1 m ³ /min
900 cfm	=	25.5 m ³ /min
950 cfm	=	26.9 m ³ /min
1000 cfm	=	28.3 m ³ /min
1500 cfm	=	42.5 m ³ /min
2000 cfm	=	56.6 m ³ /min
3000 cfm	=	85.0 m ³ /min

Conversion tables

Pressure, Length, Temperature

Pressure bar → psi

0.1 bar	=	1.45 psi
0.12 bar	=	1.74 psi
0.5 bar	=	7.25 psi
1 bar	=	14.5 psi
2 bar	=	29 psi
2.5 bar	=	36.25 psi
3 bar	=	43.5 psi
5 bar	=	72.5 psi
10 bar	=	145 psi
14 bar	=	203 psi
20 bar	=	290 psi
25 bar	=	362.5 psi
30 bar	=	435 psi
35 bar	=	507.5 psi
40 bar	=	580 psi
100 bar	=	1450 psi
200 bar	=	2900 psi
300 bar	=	4350 psi
400 bar	=	5800 psi

Length mm → inch

10 mm	=	0.39 inch
20 mm	=	0.79 inch
30 mm	=	1.18 inch
40 mm	=	1.57 inch
50 mm	=	1.97 inch
60 mm	=	2.36 inch
70 mm	=	2.76 inch
80 mm	=	3.15 inch
90 mm	=	3.54 inch
100 mm	=	3.94 inch
150 mm	=	5.91 inch
200 mm	=	7.87 inch
250 mm	=	9.84 inch
300 mm	=	11.81 inch
350 mm	=	13.78 inch
400 mm	=	15.75 inch
450 mm	=	17.72 inch
500 mm	=	19.69 inch

Temperature °C → °F

-30 °C	=	-22.0 °F
-10 °C	=	14.0 °F
0 °C	=	32.0 °F
10 °C	=	50.0 °F
30 °C	=	86.0 °F
50 °C	=	122.0 °F
80 °C	=	176.0 °F
100 °C	=	212.0 °F
120 °C	=	248.0 °F

Further information

Selection

Compressor animation

DVD

Order no. 19 943 50 100

(multilingual)

CD-ROM

Order no. 19 943 50 200

(multilingual)



Air cleaners

Catalogue

Order no. German: 19 941 10 100

Order no. English: 19 941 10 101

Further languages available on request.



Filters for liquids

Catalogue

Order no. German: 19 942 10 100

Order no. English: 19 942 10 101

Further languages available on request.



Coolant expansion tanks

Catalogue

Order no. German: W9 944 10 100

Order no. English: W9 944 10 101

Further languages available on request.



Catalogues: www.mann-hummel.com/en/corp/services/catalogues

Request form for compressor filters

Your data

(company name, address, tel. no.)

Compressor type



stationary



mobile

Basic data

Drive output [kW]	Ambient conditions [°C / mbar]	Operating temperature [°C]	Gas to be compressed Ambient air / other

Configuration data

Separators		Oil filters	Air cleaners
FAD [m³/min]	P _{Pressure reservoir} [bar]	Volume flow [l/min]	FAD [m³/min]
Oil type	Oil type	Initial pressure drop [mbar]	
Scavenge flow [g/m³]	Separation efficiency [ISO 16889] nom. β _s =2 (50 %) / abs. β _s =100 (99 %)	Max. permitted pressure drop [mbar]	
Max. residual oil volume [mg/m³]	Bypass valve opening pressure [bar]	Dust type / dust concentration [mg/m³]	
Required dimensions	Required dimensions	Dimensions	
Ø Element:	Ø:	Ø:	
Length:	Length:	Length:	
Ø Flange:	Thread:	Raw air connection:	
		Clean air connection:	
Service interval	Service interval	Service interval	

Further information:

If possible please provide us with a drawing of your pressure reservoir and a connection plan. We will naturally handle these documents in the sense of the standard ISO 16016.

Please fill in this form as best as possible and send it to your MANN+HUMMEL partner.

MANN+HUMMEL Group



The MANN+HUMMEL Group is a company with international operations and employs 16,000 people worldwide at more than 60 international locations. The company develops, produces and sells technically complex components and systems for the automotive industry and the field of mechanical engineering. A key area is high quality filtration products for vehicles, engines and

industrial applications. The OEM business with leading global manufacturers in the fields of vehicles, machines and plant form the basis for the quality and high performance of the products. Filters for the international aftermarket are sold under numerous well-known customer brands as well as under the company's own MANN-FILTER brand.

MANN+HUMMEL GMBH

67346 Speyer · Germany

Tel.: +49 (62 32) 53-80

Fax: +49 (62 32) 53-88 99

Mail: if.info@mann-hummel.com

Web: industrialfilters.mann-hummel.com

Catalogues: www.mann-hummel.com/en/corp/services/catalogues

MANN+HUMMEL Industriefiltration

The Industrial Filtration Business Unit with its headquarters in Speyer, Germany, specialises in meeting the requirements of off-highway vehicle and engine applications, compressed air and vacuum technology, mechanical engineering and plant construction. Under the Vokes Air brand the company also produces filtration solutions for HVAC and process air applications.

MANN+HUMMEL Industrial Filtration offers high performance products for these and other industrial fields for the filtration and separation of air, gases and liquids.

Thanks to the quick and easy distributor/partner network and its global sales networks the products are available at any time at almost any location.