

2017

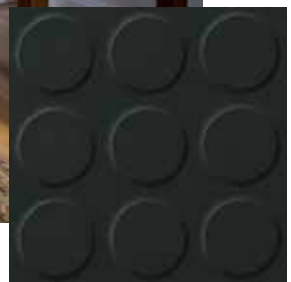

Product catalogue
Aritco Home Lifts
Aritco 4000, Aritco 6000

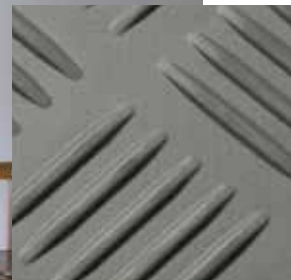

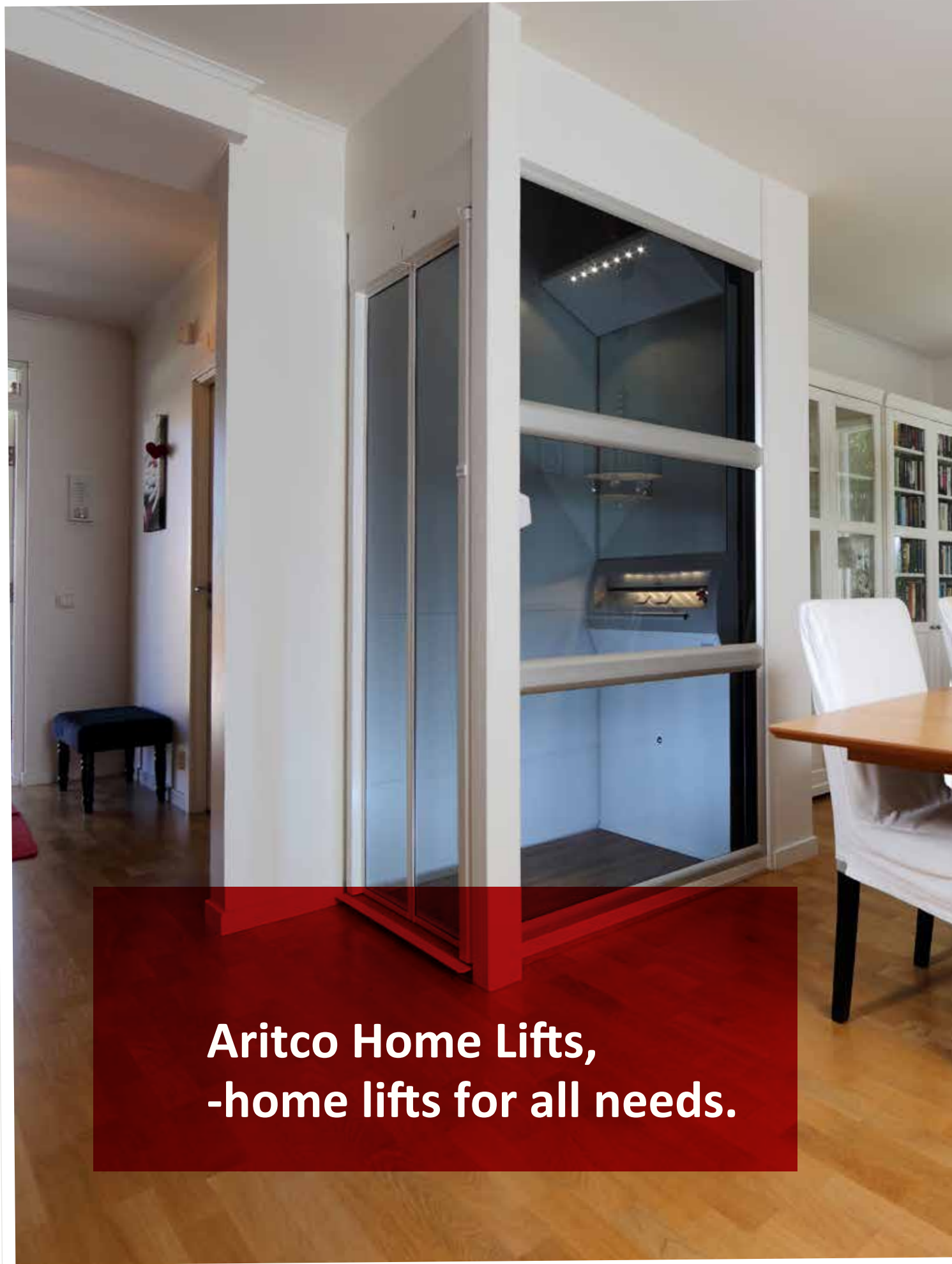

**Aritco Home Lifts,
-home lifts for all needs.**



This catalogue is primarily made for all our partners around the world. The purpose is to show what Aritco can offer in terms of products, options and possible combinations.

Product summary.....	4
Platform	6
Door	14
Shaft	28
Communication.....	32
Drive.....	33
Drawings	36
FAQ	46
Features and benefits	49
Order information	50
Overview of the platforms.....	51

Due to continuous product development, specifications are subject to change without notice. With reservations for misprint and articles out of stock.

Aritco 4000 - the world's smallest home lift

Aritco 4000 is the smallest and most compact home lift in our product range and on the market. The lift has been designed to meet all requirements for comfort, space and design. The lift is available in several different sizes, with an option to personalize it with details such as glass walls, a range of varied colours and different materials.



Aritco 4000	
Technical compliance:	European Machine directive 2006/42/EC European standard EN 81-41
Drive system:	Patented screw/nut system
Rated speed (max):	0,15 m/s
Travel height:	250 -13 000 mm
Number of stops:	Max. 6 stops per lift
Number of doors:	Max. 6 doors per lift
Number of doors per floor:	Max. 2 doors per floor
Pit:	50 mm (no pit is required when there is a threshold/ramp)
Top height:	Always 2 300 mm
Platform control:	"Hold to run", the destination button must be kept pressed down during the whole ride
Landing control (on door):	One-touch call
Environment:	Indoor
Emergency lowering:	Battery operated emergency lowering
Control voltage:	24V
Motor:	1,5kW
Power supply:	1-phase 230V 50Hz/6.6A/16A slow
Rated load:	250 kg

Platform

Aritco 4000 is available in 3 different platform sizes. The rated load is 250 kg and the power supply needed is 230 V 1-phase.

Platformsize B –side x A/C-side (mm)	Max load (kg)	Power supply
805 x 580	250	230 V 1-phase
805 x 880	250	230 V 1-phase
805 x 1080	250	230 V 1-phase

Frequency 50 or 60 Hz.
Frequency Converter always included.

Aritco 6000 - our most versatile home lift

Aritco 6000 is our most versatile home lift with various options for own personalization and design. Choose among several different sizes, glass walls and colours. This is the choice for those of you who would like to customize the lift to your own liking.



Aritco 6000	
Technical compliance:	European Machine directive 2006/42/EC European standard EN 81-41
Drive system:	Patented screw/nut system
Rated speed (max):	0,15 m/s ¹⁾ ¹⁾ 0,25 m/s as option for lifts with 400 V 3-phase frequency control, for installations outside EU.
Travel height:	250 -13 000 ¹⁾ mm ¹⁾ Travel height when having a half door is maximum 3 000 mm.
Number of stops:	Max. 6 stops per lift
Number of doors:	Max. 6 doors per lift
Number of doors per floor:	Max. 2 doors per floor
Pit:	50 mm (no pit is required when there is a threshold/ramp)
Top height:	Minimum 2240 mm (1100-1600 mm with half height door)
Platform control:	"Hold to run", the destination button must be kept pressed down during the whole ride
Landing control (on door):	One-touch call
Environment:	Indoor
Emergency lowering:	Battery operated emergency lowering
Control voltage:	24V
Motor:	2,2kW
Power supply:	1-phase 230V 50 Hz/9 A/16 A slow 3-phase 230V 50 Hz/9 A/16 A slow 3-phase 400V 50 Hz/5.2 A/16 A slow
Rated load:	250 or 410 kg (depending on platform size)

Platform

Aritco 6000 is available in 6 different platform sizes. The rated load depends on the platform size.

Load limits per power supply	400V 3-phase 50Hz	400V 3-phase 60Hz	230V 3-phase 50Hz	230V 3-phase 60Hz	230V 1-phase 50/60 Hz
250 kg	•	•	•	•	•
410 kg	•	•	•	•	•

Platform floor area A/C x B (mm)	Max load (kg)
900 x 1040	250
900 x 1280	410
900 x 1480	410
1000 x 1280	410
1000 x 1480	410
1100 x 1480	410



BASEMENT

KITCHEN

Platform
Aritco 4000, Aritco 6000



Full height wall

The platform is in its basic execution delivered with a side wall (full height) including the destination panel. It comes with LED lightening and a mirror covering the panel over the destination panel as standard. The panel under the destination panel and the small roof over the mirror is painted in RAL 7042 (grey) as standard, but can be painted in any RAL colour as an option.

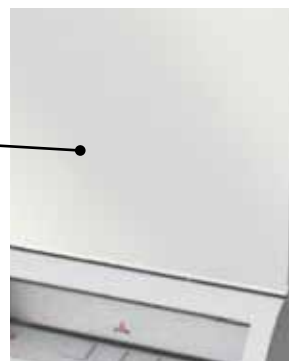

Mirror

Mirror 800 x 970 mm is included as standard.

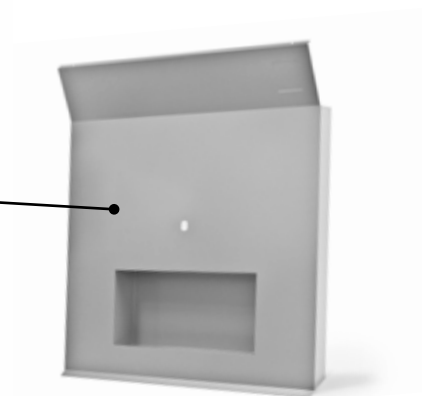

Foot box

As an option a special plate with a niche can be ordered for the bottom part of the platform. The niche adds a little bit of extra room at the bottom of the platform panel.

Size of niche: Depth 80 mm, height: 197 mm, length: 456 mm.

A,B,C and D-side of platform.

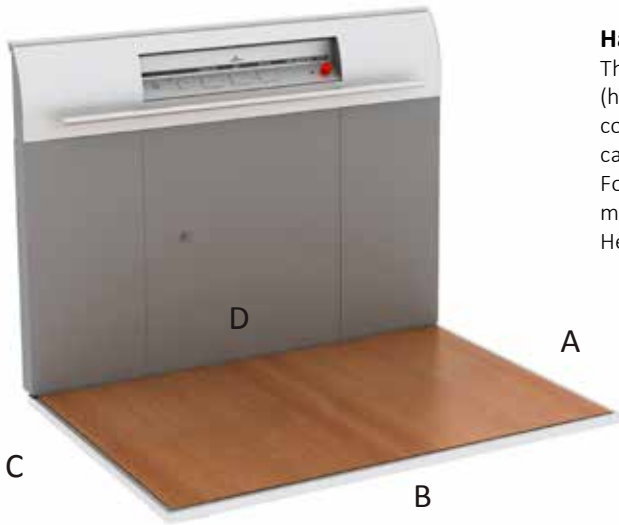

A,B,C and D-side of platform.

Half height wall

The platform is in its basic execution delivered with a side wall (half height) including the destination panel. Panels under the control panel are painted in RAL 7042 (grey) as standard, but can be painted in any RAL colour as an option. For lifts with an open shaft, half height doors or when cost must be kept down. Height 1100 mm.

Mirror

Mirror that goes along the whole machine side and that has an integrated LED light. Included as standard for full height wall.

Full height wall

To get a conventional lift feeling the Aritco 6000 can be delivered with a full height wall (2100 mm high). The full height wall has a big mirror that goes along the whole machine side. This gives the lift a nice look, for the home market. The light in the full height wall is a LED light that is hidden behind the mirror. Panels under the destination panel are painted in RAL 7042 (grey) as standard, but can be painted in any RAL color as an option.

The full height wall is available for all platform sizes . The full height wall can not be used when having a lift with half height door or doors with door opening height lower than 2000 mm. The full height wall can be ordered as an option. When ordering a full height wall for platform 900 x 1040 mm, the electrical cabinet must be external.

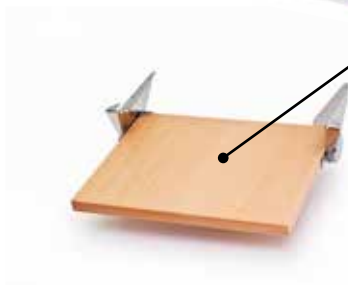

Fold down seat

In solid birch and with chromed brackets. The seat has to be folded back manually after use. Can be ordered as an option. Size: 320 x 400 mm. Not available for 900 x 1040 mm.

Overview Aritco 4000

580 x 805

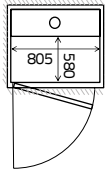

880 x 805

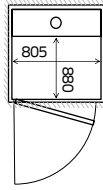

1080 x 805

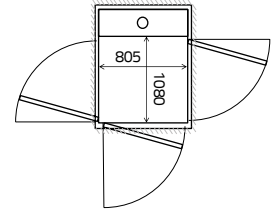

Overview Aritco 6000

900 x 1040

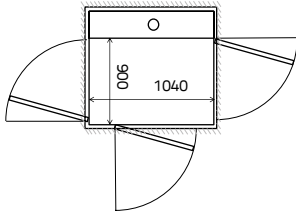

900 x 1280

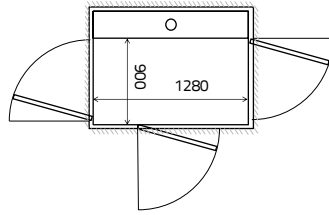

900 x 1480

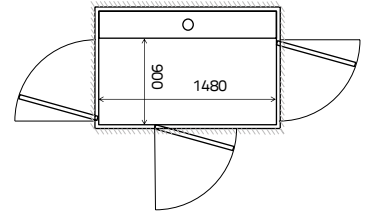

1000 x 1280

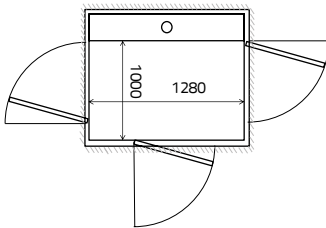

1000 x 1480

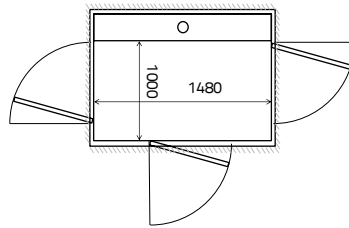

1100 x 1480

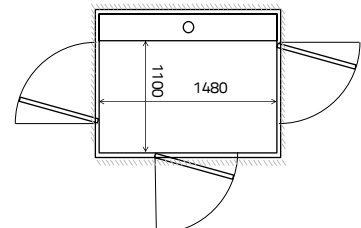

For more detailed drawings see page 36.



Destination panel

The destination panel is always placed on the machine side (D-side) of the platform. It contains the destination buttons, emergency stop, alarm button, autodialer (option), landing indicator (option), Aritco logo, max weight and number of persons allowed.

All text and logos are screen printed to ensure good quality.

- Anodized aluminum - standard
- Stainless steel - option



Destination buttons

Destination button with background lit frame, which indicates when the button is pressed down (green light). There are no signs on the destination buttons, instead it is possible to have your own text above the destination buttons on the destination panel.

Depending on the number of levels on the lift the destination buttons are either placed horizontally or vertically.

For a 2-3 level lift:

- Maximum 10 characters. Destination buttons are placed horizontally.

For a 4-6 level lift:

- Maximum 7 characters. Destination buttons are placed vertically.

All texts and logos are screen printed on the platform to ensure good quality and flexibility.

The destination buttons will have the same finish as the destination panel.

- Destination panel and destination buttons in aluminum (standard)
- Destination panel and destination buttons in stainless steel (option)

Handrail

Handrail with a straight shape.

- Anodized aluminum (standard)
- Stainless steel (option)



Alarm button

A standard alarm button is always delivered with the lift. When it is pressed a buzzer sounds. This is only a signal to the user that the button is pressed. The alarm button may be connected to an external alarm sounder or an autodialer.

External alarm sounder

External alarm sounder mounted outside the lift. It is connected to the alarm button and when the alarm button is pressed the external alarm sounder will give a loud signal outside the lift to attract attention in case of emergency. Can be ordered as an option.



Faceplate panel

The faceplate panel in anodized aluminum (chemically polished) gives a soft finish to the platform. To prevent any trapping, a safety list is mounted behind the faceplate panel which cuts off the security circuit when pressed down.



ASSA



Telemecanique

Key switch on platform

Key switch placed on destination panel. The key switch locks the platform functions and prohibits unauthorized use. One key switch per platform can be provided. The key switch can be serial connected to all destination buttons or to one destination button, i.e. you need to use the key to go to a certain floor.

Two brands to choose from:

- ASSA (Nordic markets only). Aritco only delivers the housing, Aritco does not deliver the locking cylinder.
- Telemecanique

Can be ordered as option.

Light

LED lights are installed over the destination panel.



Emergency stop button

Button in "mushroom" type for emergency situations. Is always included as standard.



Landing indicator

Digital display positioned at the destination panel. It shows which floor the lift is on at the moment. The indicator can also be fitted with a voice announcer available in Danish, Dutch, English, Finnish, French, German, Norwegian, Polish, Russian and Swedish. Voice: Basement, Ground floor, Floor 1-6

The landing indicator can also show information from the system.

- Warning if the batteries are low.
- A bell when the alarm button has been pressed.
- Number of starts and total run time since installation or since last reset.
- A weight symbol will appear if the lift is overloaded.
- If connected to the buildings fire alarm a "Fire" symbol will be shown when alarm is activated.

Can be ordered as an option.

Note that when ordering your own text above the destination buttons, the landing indicator with voice will not be able to say these words.



Flooring

Vinyl, rubber or simply no flooring at all. Choose between following options:

Standard:



Classic Walnut
Vinyl



Oiled Oak
Vinyl

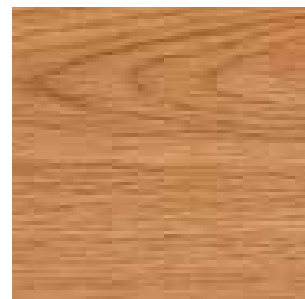

European oak
Vinyl

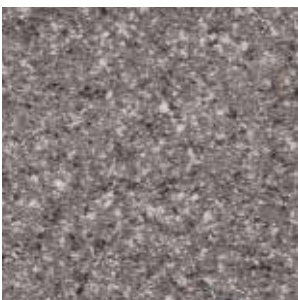

Mineral – Grey
Vinyl

Option:



Checker – Grey
Rubber

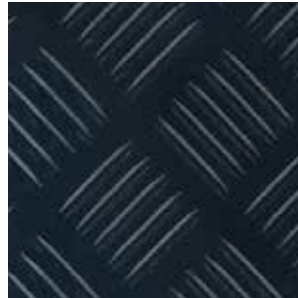

Checker – Black
Rubber



Checker – Red
Rubber



Checker Stud – Black
Rubber



Checker Stud – Grey
Rubber

The platform is prepared for other types of floors with maximum tickness of 3 mm without any modifications.





News. New door profiles possible to paint in any RAL-colour.

Door Aritco 4000, Aritco 6000

General information

The landing doors installed at each landing are made of toughened galvanized steel and laminated and toughened glass, 8 mm thick. All doors for Aritco 4000 are painted in RAL 9003 (Aritco white) but can be painted in any RAL colour as an option. The door frame and door blade can be painted in the same colour or the frame in one colour and the blade in another colour. For the same lift all doors must be painted in the same colour.

A glassed area according to EN81-41 is standard for all doors. Standard is with tinted glass (JT16). Optional is to have clear (JT0), dark tinted (JT5) or frosted glass (JT23).

The profiles around the glass are made of aluminium. The profiles can be painted in any RAL colour. If the door blade is in RAL 9003 (Aritco white) the profiles can be painted in the same colour as an option. If the door blade is painted in another RAL colour, the profiles will be in aluminium as standard, but can be painted in the same RAL colour as the door blade as an option. Note that aluminium profiles are standard and that painted profiles are an option.

All doors can be left- or right hinged. Doors are always delivered with door frames. It is not possible to order the door or the frame separately. Doors on B side are 800 mm wide. It is also possible to have doors on the A and C side for platform size 1080 mm. These doors are 900 mm wide.

Large glass door

Large glass door with one glass window.

Opening widths: 800, 900 mm

Opening heights: 1800, 1900, 2000 mm

The actual height of the door is 40 mm higher since a plate that covers the joint between the door and the frame is mounted on the door.

Glass window (vision): 612x1472 mm (800 mm wide door)
712x1472 mm (900 mm wide door)

Standard:

- Door blade and door frame in RAL 9003 (Aritco white)
- Glass window: tinted glass (JT16)

Options:

- Door blade and / or door frame in other RAL colour
- Glass window: clear (JT0), dark tinted (JT5), frosted (JT23)



Door opening width (mm)	Door opening height (mm)	Available for B-side (mm)	Available for A/C side (mm)
800	1800 ¹⁾ /1900 ¹⁾ /2000	805	-
900	1800 ¹⁾ /1900 ¹⁾ /2000	-	1080

¹⁾ Not available on top floor since top height of shaft is always 2300 mm

Double hinged glass door

Double hinged glass doors are made of 17,5 mm laminated glass and always delivered with two internal door openers which opens the doors automatically. If the space in front of the door is limited it is a good solution to use the double hinged glass door.

Opening width: 800, 900 mm

Opening height: 2000 mm

The actual height of the door is 40 mm higher since a plate that covers the joint between the door and the frame is mounted on the door.

Door blade: Two blades 400 mm or 450 mm wide

Glass window (vision): Two glasses 332 x 1950 mm or 394 x 1950 mm

Standard:

- Door blade and door frame in RAL 9003 (Aritco white)
- Glass window: tinted (JT16)

Options:

- Door blade and /or door frame in other RAL colour
- Glass window: clear glass (JT0), dark tinted (JT5), frosted (JT23)



Door opening width (mm)	Door opening height (mm)	Available for B-side (mm)	Available for A/C-side (mm)
800	2000	805	-
900	2000	-	1080

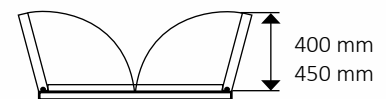

Door - Aritco 4000

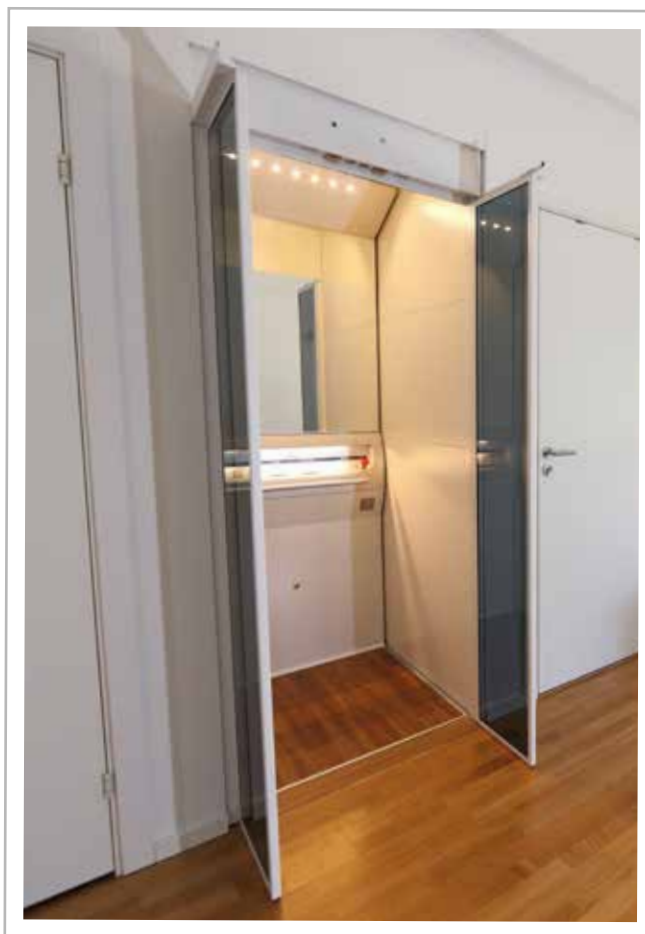

Door frame

On the A and C side the door is always delivered with a frame. The height of the frame depends on the door opening height and is always 240 mm higher than the door opening height. On the B-side there is no place for a door frame and the door is mounted without a frame. Frame size on A/C-side 1160 mm.

Door opening height (mm)	Frame height (mm)
1800	2040
1900	2140
2000	2240

Door opening height

The actual height of the door is 40 mm higher since a plate that covers the joint between the door and the frame is mounted on the door. For door opening height 2000 mm the actual door height is 2040 mm.

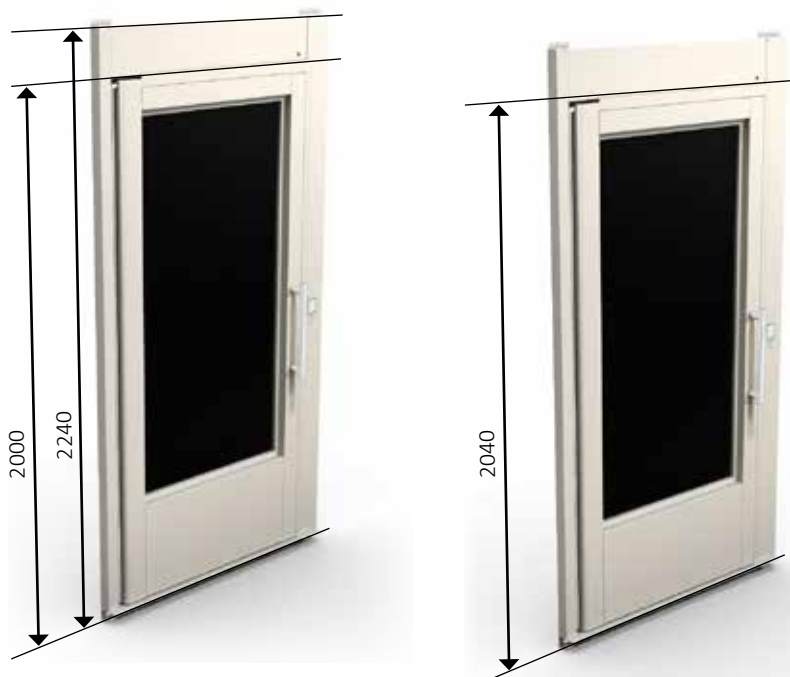

Examples with door opening height 2000 mm.

General information

The landing doors installed at each landing are made of toughened galvanized steel and laminated and toughened glass, 8 mm thick.
 All doors for Aritco 6000 are painted in RAL 9003 (Aritco white) but can be painted in any RAL colour as an option. The door frame and door blade can be painted in same colour or the frame in one colour and the blade in another colour. For the same lift all doors must be painted in the same colour.
 A glassed area according to EN81-41 is standard for all doors. Standard is with clear glass (JT0). Optional is to have tinted (JT16), dark tinted (JT5) or frosted glass (JT23).
 The profiles around the glass are made of aluminium. The profiles can be painted in any RAL colour. If the door blade is in RAL 9003 (Aritco white) the profiles can be painted in the same colour as an option. If the door blade is painted in another RAL colour, the profiles will be in aluminium as standard, but can be painted in the same RAL colour as the door blade as an option. Note that aluminium profiles are standard and that painted profiles are an option.
 All doors can be left- or right hinged. Doors are always delivered with door frame. It is not possible to order the door or the frame separately.



Large glass door

Large glass door with one glass window.

Opening widths: 800, 900 mm

Opening heights: 1800, 1900, 2000, 2100 mm

The actual height of the door is 40 mm higher since a plate that covers the joint between the door and the frame is mounted on the door.

Glass window (vision): 612x1472 mm (800 mm wide door)
 712x1472 mm (900 mm wide door)

Standard:

- Door blade and door frame in RAL 9003 (Aritco white)
- Glass window: clear glass (JT0)

Options:

- Door blade and /or door frame in other RAL colour
- Glass window: tinted (JT16), dark tinted (JT5), frosted (JT23)

Door opening width (mm)	Door opening height (mm)	Available for B-side (mm)	Available for A/C side (mm)
800	1800/1900/2000	1040	900
900	1800/1900/2000/2100	1280/1480	1000/1100

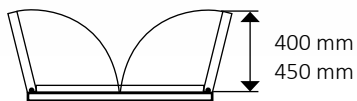

Double-hinged glass door

Double hinged glass doors are made of 17,5 mm laminated glass and always delivered with two internal door openers which opens the doors automatically. If the space in front of the door is limited it is a good solution to use the double hinged glass door.

Opening width: 800, 900 mm

Opening height: 2000 mm

The actual height of the door is 40 mm higher since a plate that covers the joint between the door and the frame is mounted on the door

Door blade: Two blades 400 mm or 450 mm wide

Glass window (vision): Two glasses 332 x 1950 mm or 394 x 1950 mm

Standard:

- Door blade and door frame in RAL 9003 (Aritco white)
- Glass window: clear glass (JT0)

Options:

- Door blade and /or door frame in other RAL colour
- Glass window: tinted (JT16), dark tinted (JT5), frosted (JT23)

Door opening width (mm)	Door opening height (mm)	Available for B-side (mm)	Available for A/C-side (mm)
800	2000	1040	900
900	2000		1000/1100

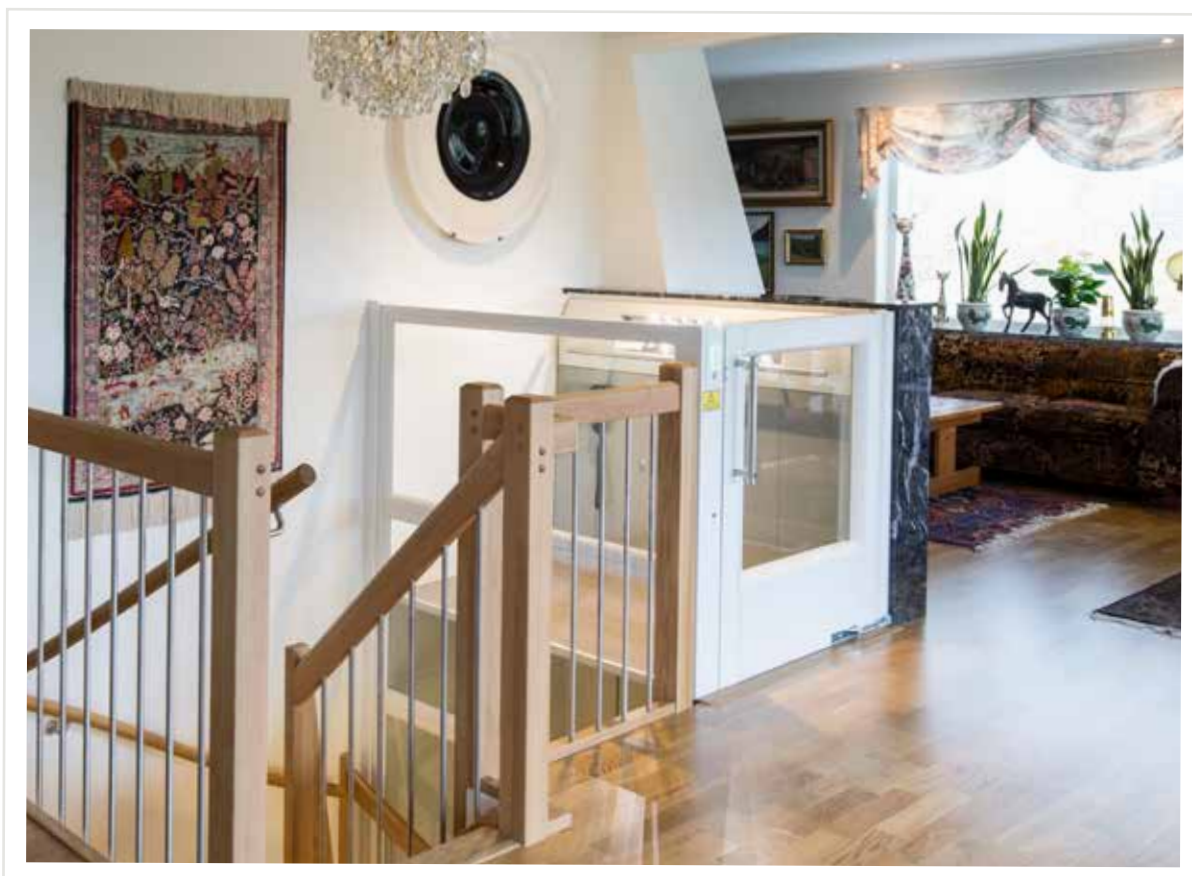

Half height door with glass

Half height door with one glass window. If you require an open shaft or if the head space is low, the use of a half height door may be a good solution. According to EN81-41 the half height door is only allowed for lifts with a travel height up to 3 meters (within EU). The half height door can not be combined with EI60 fire & smoke proof doors.

Opening widths : 800, 900 mm

Opening heights: 1100-1600 mm

Glass windows (vision): 612x670 mm (800 mm wide door)
712x670 mm (900 mm wide door)

Standard:

- Door blade and door frame in RAL 9003 (Aritco white)
- Glass window: clear glass (JT0)

Options:

- Door blade and /or door frame in other RAL colour
- Glass window: tinted (JT16), dark tinted (JT5), frosted (JT23)

Note that when using a half height door 1100-1600 mm the shaft and the half height door will end at the same height. It is not possible to have a higher shaft than the half door.



Door opening width (mm)	Door opening height (mm)	Available for B-side (mm)	Available for A/C-side (mm)
800	1100 1101-1600 ¹⁾	1040	900
900	1100 1101-1600 ¹⁾	1280/1480	1000/1100

¹⁾ Custom height

A half height door can be used in the following cases:

- *1100 mm high half height door:*
When you have an open shaft and a top height of 1100 mm (even shaft).
- *1101-1600 mm high half height door:*
When you have a low travel height with a standard door on the bottom floor and a custom height half height door is needed to get an even shaft (see page 20 for details).
When you have a higher travel height, but a standard door on second top floor and a custom height half door is needed to get an even shaft.
- It is not possible to have a lower half height door than the top height of the shaft – this means that you can't have a 1100 mm height door on a lift with shaft height of for example 1400 mm.
- Note that it is not possible to have two half height doors on the same lift.

Door - Aritco 6000

Travel heights

When using a customised height half door, consider the following criteria regarding travel height. Note that the travel height is depending on if the lift is installed with or without a pit.

For large glass door, double glass door and double hinged glass door.

Door opening height (mm) ¹⁾	Travel height when a ramp on first level (mm)	Travel height with a pit on first level (mm)
1800	490 – 990	440 – 940
1900	590 – 1090	540 – 1040
2000	690 – 1190	640 – 1140
2100	790 – 1290	740 – 1240

¹⁾ The height of the frame is always 240 mm higher than the door opening height.

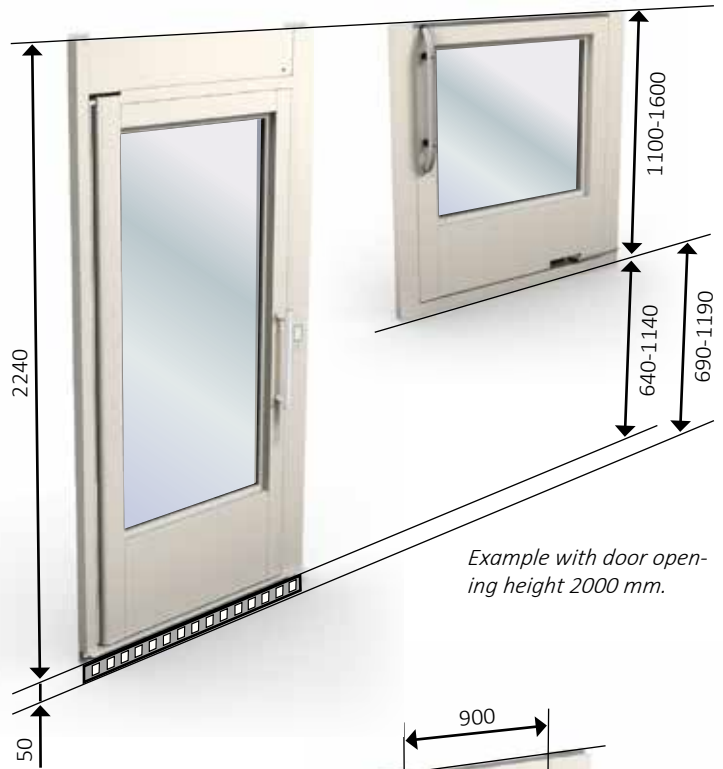

Example with door opening height 2000 mm.

Door frame

A door frame is always delivered with the door. The size of the frame depends on the platform size and the door opening width and height. The height of the frame is always 240 mm higher than the door opening height.

Door opening height (mm)	Frame height (mm)
1800	2040
1900	2140
2000	2240
2100	2340



Example with door opening height 2000 mm.

A/C -side

Platform side (mm)	Frame size (mm)
900	1060
1000	1160
1100	1260

B -side

Platform side (mm)	Frame size (mm)
1040	1060
1280	1300
1480	1500

Door opening height

The actual height of the door is 40 mm higher since a plate that covers the joint between the door and the frame is mounted on the door. For door opening height 2000 mm the actual door height is 2040 mm.



Example with door opening height 2000 mm.

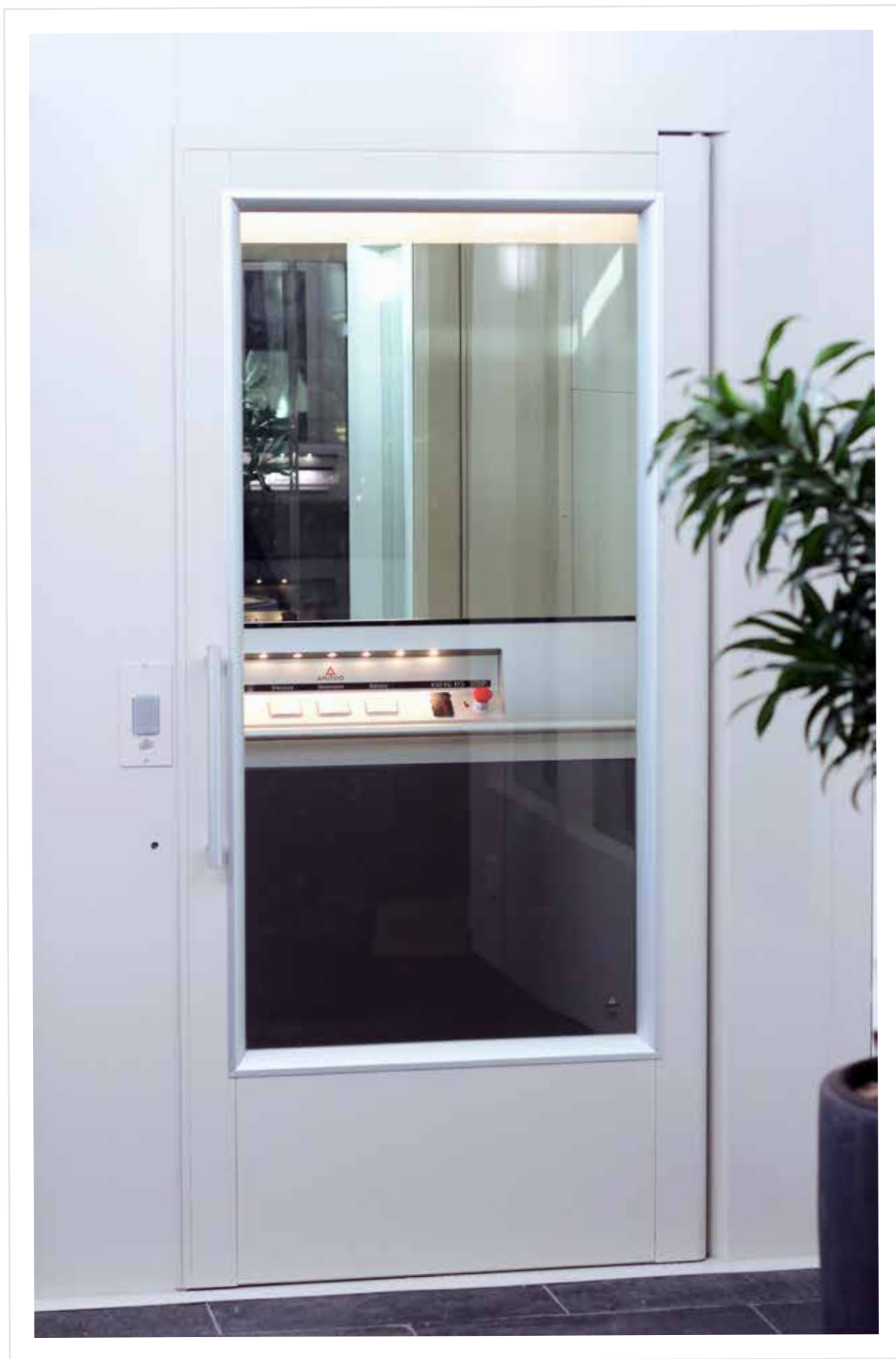

Displacement of door on B-side

If it is not possible to fit the door on the B-side in the standard location, it is possible to place the door to the left or to the right. This is only possible for doors with door opening width 900 and for doors on B-side; 1280 and 1480 mm. Large glass door and half height doors can be displaced. It is not possible to displace EI60 fire & smoke proof doors or double hinged glass doors.

Door opening 900 mm.

Platform size on B-side (mm)	Frame size (mm)	Standard frame (mm)	Displaced to the left (mm)	Displaced to the right (mm)
		Left / Right side of door	Left / Right side of door	Left / Right side of door
1280	1300	200 / 200	130 / 270	270 / 130
1480	1500	300 / 300	130 / 470	470 / 130

Examples of possible displacement of door on B-side (door opening 900 mm, platform size on B-side 1480 mm, frame 1500 mm) :

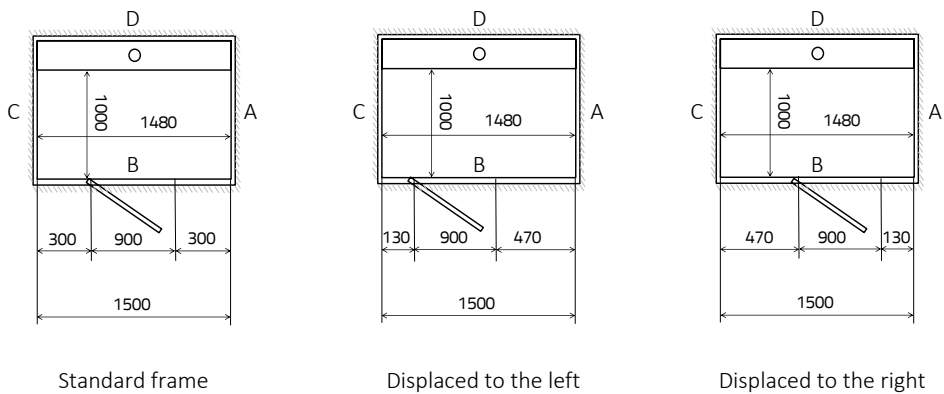



EI60 – Fire & smoke proof door

EI60 – Fire & smoke proof door complies with the lift directive 95/16/EC and EN 81-58. As standard the EI60 door is delivered with a frame. As an option a widening panel for the A and C side can be ordered to cover the machine side part. The widening panel is available with or without a hatch to cover the electrical cabinet.

Opening width: 800, 900 mm

Opening height: 1900, 2000, 2100 mm

The actual height of the door is 20 mm higher since a plate that covers the joint between the door and the frame is mounted on the door.

Installation: Not in combination with half height door.

Standard:

- Door blade and door frame in RAL 9003 (Aritco white)
- Glass window: clear glass (JT0)

Options:

- Door blade and /or door frame in other RAL colour

Door opening width (mm)	Door opening height (mm)	Available for B-side measure (mm)	Available for A/C - side measure (mm)
800	1900 2000/2100	1040	900
900	1900 2000/2100	1280/1480	1000/1100

EI60 – Fire & smoke proof door frame

A door frame is always delivered with the door. The size of the frame depends on platform size and the door opening width and height. The height of the frame is always 220 mm higher than the door opening height.

Door opening height (mm)	Frame height (mm)
1900	2120
2000	2220
2100	2320

B-side

Platform side (mm)	Frame size (mm)
1040	1060
1280	1300
1480	1500

A/C-side

Platform side (mm)	Frame size (mm)
900	1060
1000	1160
1100	1260

For B-side 1580 mm and 1980 mm fire doors are not available.

Widening panel for A and C side

As an option a widening panel for the A- and C-side can be ordered to cover the machine side part. The widening panel is available with or without a hatch for the electrical cabinet. The widening panel is available for door opening height 1900, 2000 and 2100 mm and has the same height as the door frame.

Door - Aritco 4000 and Aritco 6000

Door control

The door control is either placed on the door frame of each landing door and/or placed away from the lift as an external control.



Door control on door frame

Door control placed on the door frame on the lift. For Aritco 6000 there is always place on the door frame for a door faceplate (except when having double hinged glass doors). For Aritco 4000 there will only be place for a door faceplate on the A and C side (except when having a double hinged glass door).



Call button

The call button comes with a background lit frame which indicates the status of the lift.

- Green light indicates that the lift is at your floor. Lit only on the floor where the platform is at the moment.
- Red light indicates that the lift is occupied. It is busy and you can't call for it.
- The flashing light indicates that the security circuit is broken, e.g. that the emergency button is pressed, the door is open on another floor for more than one minute, the door is blocked or the safety frame is pressed down. The flashing light can also be activated by a sum alarm, more information is then available in the service memory.

The same call button is used when the door control is placed on the door frame, externally or as a radio controlled call button.



Call button

Telemecanique



ASSA

EUR

Door faceplate

The door faceplate can be placed directly on the door frame or externally in an external call station box. The door faceplate is painted in the same colour as the door frame. Standard colour is RAL 9003 (Aritco white), if the door frame is painted in another colour the faceplate will be painted in the same colour.

The door faceplate can hold:

- Call button
- Key switch Telemecanique / School locking
- Key switch prepared for Assa / School locking
- Key switch prepared for EUR / School locking



ASSA

EUR

Telemecanique

Key switch / School locking

Instead of having a normal call button on the door faceplate you can have a key switch. You then need to have the key to be able to call for the lift and to access the lift. Includes school locking function which automatically locks the door 10 seconds after it is closed.

Two brands to choose from:

- ASSA (Nordic markets only). Aritco only delivers the housing, Aritco does not deliver the locking cylinder.
 - EUR, Aritco only delivers the housing. Aritco does not deliver the locking cylinder.
 - Telemecanique
- Aritco can provide one key switch per door.

External door control – placed away from lift

Door control placed away from the lift in an external call station box connected to the lift via a cable or as a radio controlled call button without any cable.

For Aritco 4000 when having a door on the B-side there is no frame and thus no place for a door faceplate.

Standard solution for the B-side on Aritco 4000 is to have the call button in a white plastic box. It is also possible to have an external call station box. Both connected to the lift with a cable.

Note that for double hinged glass doors there is no place for door control in the door frame. External door control must be used.



Radio controlled call button

The radio controlled button, placed in a white plastic box, gives the customer the freedom to place the call button wherever they would like within 10 meters from the lift. The radio controlled call button runs on batteries and provides remote controlled access to the lift. The radio controlled call button doesn't indicate the status of the lift.

Can be ordered as an option.



Call button in white plastic box

Aritco 4000 does not have a door frame on the B-side of the lift and therefore there is no place for a door faceplate on the lift. Standard solution for the B-side on Aritco 4000 is to have the call button in a white plastic box connected to the lift via a cable.



External call station box

The door faceplate can be placed away from the lift and will then be placed in an external call station box. The colour of the external call station box is RAL 9003 (Aritco white). The box can either be mounted exterior on a wall (wall mount) or in the wall so that you only see the door faceplate (flush mounted).

The external call station box can be ordered as an option.

The standard length of the cable delivered with the external call station box is 1.5 m, as an option it can be 10 m long.

Size flush mount: 82x150x50 mm

Size wall mount: 95x185x50 mm

Door - Aritco 4000 and Aritco 6000

Door machinery

The landing doors are always delivered with either a door opener or a door closer. They are mounted internally (in the door frame so that you can't see it from the outside).

Door opener: Opens and closes the door automatically. Door open time and the opening speed are adjustable.

Door closer: Door is opened manually. The door is closed automatically after a preset time.

All openers and closers are available for both left and right hinged doors.

When having two doors on the same landing, both doors will be opened at the same time when having door openers.

Door type	Internal door closer	Internal door opener
Large glass door standard	•	•
Half height glass door	•	•
EI60 – fire & smoke proof door	•	
Double hinged glass door		•



Internal door opener

Opens and closes the door automatically. It is built into the door frame and can't be seen from the outside.

Can be ordered as option.

Standard for double hinged glass doors.

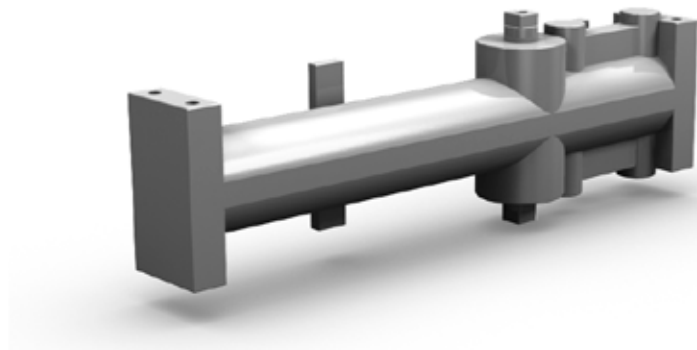

Internal door closer

Closes the door automatically after a preset time.

It is built into the door frame and is invisible from the outside.

Includes function to keep door open until the user manually closes the door. Standard for all doors except large glass doors with 50 mm frametop.



Landing indicator on door

Digital display positioned at the door frame. It shows which floor the lift is on at the moment.

The landing indicator can also show following system information:

- Warning if the lift batteries are low.
- A bell when the alarm button has been pressed.
- Number of starts and total run time since installation or since last reset.
- A weight symbol will appear if the lift is overloaded.
- If connected to the buildings fire alarm a "Fire" symbol will be shown when alarm is activated.

Door handle

Door handle in anodized aluminum with a straight shape as standard. Available in stainless steel as an option.

Note that the door handle on a door on B-side of an Aritco 4000 could hit the building wall if the lift is installed very close to the wall on A or C side. This is since the door on the B-side does not have a door frame.



Cover plate

If the door control is placed externally and not on the door frame a cover plate that covers the hole in the door frame is delivered with the lift. The cover plate is always delivered with the lift in the same colour as the door frame. Standard colour is RAL 9003 (Aritco white).

Threshold and ramp

For all lifts without a pit a door threshold in oak is delivered with the lift. A ramp can be delivered together with the door threshold for easier access to the lift. The ramp is made of galvanized steel, painted in RAL 9003 (Aritco white) as standard. If the shaft is painted in another RAL colour the ramp will be painted in the same colour. Can be ordered as an option.

It is also possible to order the threshold plates in corrugated aluminum instead of oak. In this case a ramp in galvanized steel covered with corrugated aluminum can be ordered as an option for lifts without a pit. A threshold will not be delivered in this case.



News. New shaft profiles possible to paint in any RAL colour.

Shaft

Aritco 4000, Aritco 6000

Shaft Aritco 4000

The lift is always delivered with a self supporting shaft. The top height of the shaft (distance from top floor to top of shaft) is always 2 300 mm. If the lift isn't installed against a wall, machine side cladding can be added on the outside of the lift on the machine side. For all sides except for machine side you can choose to have shaft panels in steel or glass.

Machine side cladding

The machine side cladding in steel covers the back-side of the machine side if the lift is not mounted against a wall. The machine side cladding can be ordered as an option and can run from bottom to top height. It can also be ordered partly if the lift is partly mounted to a wall. The cladding is painted in same colour as the shaft. Black plates of sound isolation materials are mounted on the machine side cladding to give the machine side a more esthetical look from inside the shaft and to reduce the noise level. Size: Travel height plus top height.

Shaft panels

Standard is 25 mm thick shaft panels with EPS (polystyrene) core and steel plates. The panels are painted in RAL 9003 (Aritco white) as standard. If the shaft is painted in another colour the shaft panels will be painted in the same colour. The height of the shaft panel is 575 mm.

Cover plate for top of the mast

Plate to cover the equipment placed at the top of the mast, such as battery operated emergency lowering). Can be ordered as an option.



Inner ceiling

Aritco 4000 always comes with an inner ceiling, painted in the same colour as the shaft walls. Standard is RAL 9003 (Aritco white). If the shaft is painted in another RAL colour the inner ceiling is painted in the same colour.

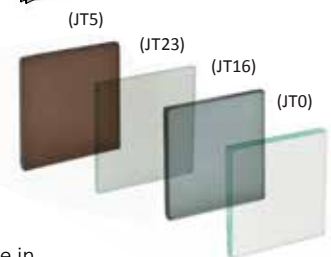
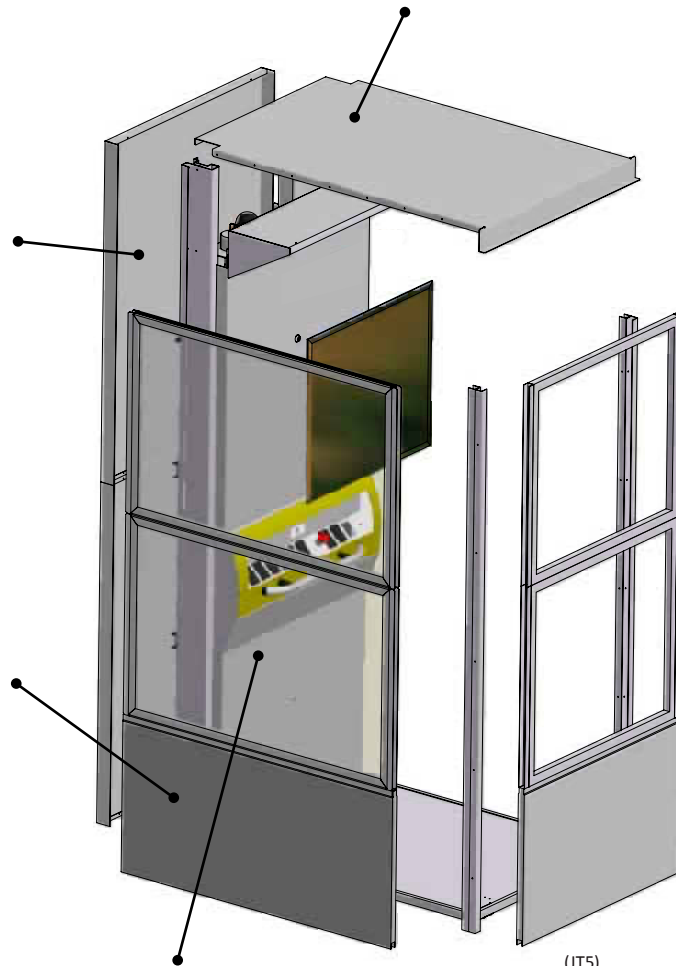

Glass

As an option glass panels with laminated and toughened glass can be ordered. Standard is tinted glass (JT16). Option with clear (JT0), dark tinted (JT5) or frosted (JT23) glass. The glass panels are 8 or 10 mm thick depending on the size of the glass. Glasses which are higher than 1000 mm is always 10 mm.

The glasses are fitted in aluminium profiles. These profiles are in aluminium as standard, but can be painted in a RAL colour as an option. For a shaft painted in the RAL 9003 (Aritco white) the profiles can be painted in the same colour. For a shaft painted in another RAL colour the profiles are as standard aluminium. As an option the profiles can be painted in the same RAL colour. Note that this has to be ordered separately.

Shaft panels / glass with aluminium profile:

Height (mm)	Clear glass (JT0)	Dark tinted glass (JT5)	Tinted glass (JT16)	Frosted glass (JT23)
736	•	•	•	•
1472	•	•	•	•
2208	•	•	•	•
Customized ¹⁾	•	•	•	•

¹⁾ Additional cost per mm. Maximum height per glass panel is 2500 mm

Shaft Aritco 6000

The lift is always delivered with a self supporting shaft. The lift always comes with cladding panels on the inside of the shaft on the machine side. If the lift is not installed against a wall, machine side cladding can be added on the outside of the lift to cover the machine side. For all sides except for the machine side you can choose to have shaft panels in steel or glass. The top height of the shaft for Aritco 6000 is not fixed. When having a standard door on the top floor, the minimum top height depends on the door opening height and the frame height. For a door opening height of 2000 mm the standard frame height is 2 240 mm, which is the lowest top height. Higher top height can be ordered.

Cladding panels

Cladding panels covering the inside of the machine side are delivered as standard. As standard the panels are in RAL 9003 (Aritco white), but if shaft is painted in another colour the panels will be painted in the same colour.

Machine side cladding

The machine side cladding in steel covers the backside of the machine side if the lift is not mounted against a wall. The machine side cladding can be ordered as an option and can run from bottom to top height. It can also be ordered partly if the lift is partly mounted to a wall. The cladding is painted in same colour as shaft panels. Size: Travel height plus top height.

Inner ceiling

For a closed shaft you could add an inner ceiling as an option. The inner ceiling is painted in the RAL 9003 (Aritco white) as standard, but will be painted in the same colour as the shaft if the shaft is painted in another colour. It comes with LED lights, which complies with LUX regulations.

See image p.28

Shaft panels

Standard is 25 mm thick shaft panels with EPS (polystyrene) core and steel plates. The panels are painted in RAL 9003 (Aritco white) as standard. If the shaft is painted in another colour the shaft panels will be painted in the same colour. The height of the shaft panel is 575 mm.

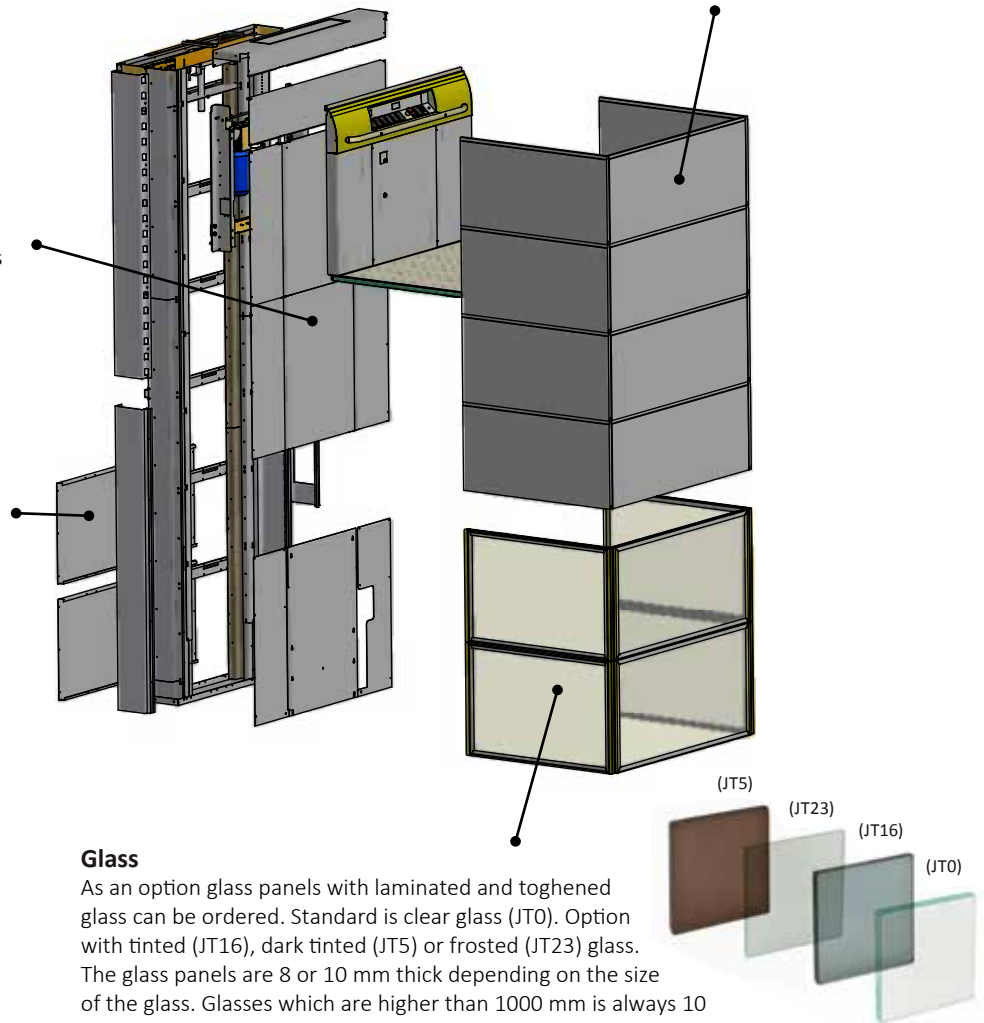

Glass

As an option glass panels with laminated and toughened glass can be ordered. Standard is clear glass (JT0). Option with tinted (JT16), dark tinted (JT5) or frosted (JT23) glass. The glass panels are 8 or 10 mm thick depending on the size of the glass. Glasses which are higher than 1000 mm is always 10 mm. The glasses are fitted in aluminium profiles. These profiles are in aluminium as standard, but can be painted in a RAL colour as an option. For a shaft painted in the RAL 9003 (Aritco white) the profiles can be painted in the same colour. For a shaft painted in another RAL colour the profiles are as standard aluminium. As an option the profiles can be painted in the same RAL colour. Note that this has to be ordered separately.

Shaft panels / glass with aluminium profile:

Height (mm)	Clear glass (JT0)	Dark tinted glass (JT5)	Tinted glass (JT16)	Frosted glass (JT23)
736	•	•	•	•
1472	•	•	•	•
2208	•	•	•	•
Customized ¹⁾	•	•	•	•

¹⁾ Additional cost per mm. Maximum height per glass panel is 2500 mm

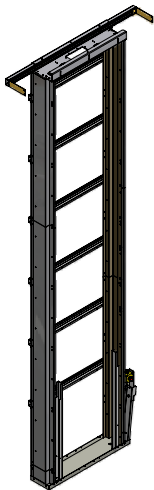

Mast

For Aritco 6000 the lift can be delivered in different ways, depending on the length of the lift.

- For travel heights 2 465 -13 000 mm the mast is always delivered in parts.
- For travel heights 1 720 – 2 464 mm the mast is delivered in parts as standard, but can be delivered in one part if required.
- For travel heights up to 1 720 mm the mast is always delivered in one part.
- For travel heights up to 2 464 mm it is possible to have the mast prepared for splitting.

For Aritco 4000 the mast is always delivered in parts.

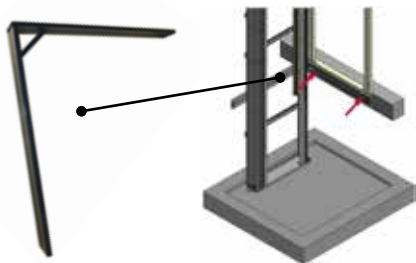

Shaft support bracket / L-bracket - Aritco 6000

Installed to stabilize the shaft when it is not mounted against a wall. One shaft support bracket shall be used per floor, except the bottom floor. The shaft support bracket/L-bracket is fixed on the lift on the machine side and in the building on A/C-side (under door). Not possible to fix on B-side. The shaft support bracket / L-bracket is available for platform sizes 1040, 1280 and 1480 mm.

The shaft support bracket /L-bracket is painted in RAL 9003 (Aritco white) as standard. If the shaft is painted in another color the shaft support bracket is painted in the same color.



Shaft support frame - Aritco 4000

Used as an alternative fixing method when the mast is not mounted against a wall. One support frame for each floor is needed, except for bottom floor. The support frame is painted in RAL 9003 (Aritco white) as standard. If the shaft is painted in another colour the support frame will be painted in the same colour. The support frame consists of four jointed parts, designed for the 1080 mm platform. However, two of the balks are prepared with small drilled holes so they can be cut to fit the other, smaller platform sizes.



Electrical cabinet - Aritco 6000

The standard position of the electrical cabinet is in the shaft, at the upper floor where the landing door is located. If the standard position of the electrical cabinet proves difficult we offer the option to move it to another landing or to place it externally in a locable casing.

For platform size 900x1040 mm the electrical cabinet is mounted behind the platform panel and in the top of the shaft. When ordering a full height wall for platform 900x1040 mm, the electrical cabinet must be external.

Size of standard electrical cabinet (placed in shaft): 180 x 880 mm.

Size of external electrical cabinet (placed in an external box): Height 500 mm, depth: 160 mm, width: 400 mm.



External service panel

A service panel is always placed in the electrical cabinet. It is used to run tests etc., and for emergency running the lift. An external service panel is available for mounting outside the lift as an option. In this case a wire connects it with the service panel in the electrical cabinet.

For Aritco 6000 platform size 900 x 1040 and for all platform sizes for Aritco 4000 the electrical cabinet and the standard service panel is mounted in the top part of the shaft and can't be reached from outside. Therefore it is connected to an external service panel (wall mount) which is mounted in a faceplate box. The external service panel must be activated with a 3 edge key before it can be used.

Size: 95 x 185 mm

Extra anti-rust protection

In order to protect the lift when exposed to humid environments, e.g. when sea transport or when the packed lift is exposed to humid conditions during transport or at the installation site, the lift is delivered with guides (corrosion class C5). Can be ordered as an option.

Two way communication is mandatory according to EN81-41. Choose from one of the following options or install your own phone.

Autodialer

Equipment for emergency calls. Integrated on the destination panel. Dials automatically when the alarm button is pressed.

When unanswered after a predefined time, the call is automatically forwarded to the next number.

The autodialer can be equipped with a GSM module. Aritco does not supply SIM card.



DC converter

When more autodialers are connected in series on one phone line the power on the phone line is not enough to drive more than one autodialer. In this case, a DC-converter is needed for each lift. The DC-converter 12-24 V is used as external power supply for the autodialer.

Phone

The telephone works as a standard telephone but is intended for emergency calls.

The phone is mounted on the platform panel. Equipped with redial memory, mute button and a lamp indicator for on/off.

Can be equipped with a GSM module. Aritco does not supply SIM card.





Power supply

For Aritco 6000 you have the following options:

3-phase 400V 5.2 A / 16 A slow

- Standard for all lifts (50 Hz)
- Frequency 50 or 60 Hz
- Frequency converter, with build in soft start and stop (option).

1-phase 230V 9 A / 16 A slow

- Option when building doesn't support 400V 3-phase
- Frequency converter, with built in soft start and stop
- Frequency 50 or 60 Hz

3-phase 230V 9 A / 16 A slow

- Option
- Note that this is rarely used except for example in Norway and Saudi Arabia
- Frequency 50 or 60 Hz

For Aritco 4000 the following is valid:

1-phase 230 V / 6.6A / 16A slow

- Frequency converter with built in soft start and stop
- Frequency 50 or 60 Hz

Soft start

For Aritco 6000, 3-phase lifts, where you don't have frequency control, soft start is standard. It gives a smoother start when a destination button is pressed and the lift starts.

Battery guard

The battery guard ensures that the batteries are not damaged and that there is enough power so that you can run the lift in the case where the power to the lift is cut. It ensures that the lift is turned off (all power consumers are turned off) when the power of the batteries reaches 22 V. This means that when you go on vacation you don't need to turn off the lift even if you turn off the power in the house, the battery saver will ensure that the batteries are not discharged. The battery guard can be ordered as an option.



Lubrication

The screw must be oiled at regular intervals.

Manual Lubrication

A brush fixed to the platform oils the screw when using the lift (a tray with lubrication oil in the bottom of the shaft). Standard for Aritco 6000. Not applicable for Aritco 4000.

Automatic Lubrication

Oils the driving screw at regulated time intervals even if the lift is not in use. The lubrication frequency is adjustable. Standard for Aritco 4000. Option for Aritco 6000. Standard for lifts with a travel height of over 8000 mm. Recommended for lifts that are seldom used or that are not used regularly to travel from ground to top floor.



Battery operated emergency lowering

All Aritco lifts have battery operated emergency lowering as standard. You can lower yourself from inside the lift and get out by yourself when there is a power failure. Possible to run the lift to nearest level from the platform (possible to go down) - Executed when pressing a destination button. Can also be run externally from the call button (hold to run) or service box.

Phase sequence relay

Extra protection and to secure that the lift does not run in the wrong direction when the phases are connected incorrectly. Option introduced for Aritco 6000, 3-phase lifts.



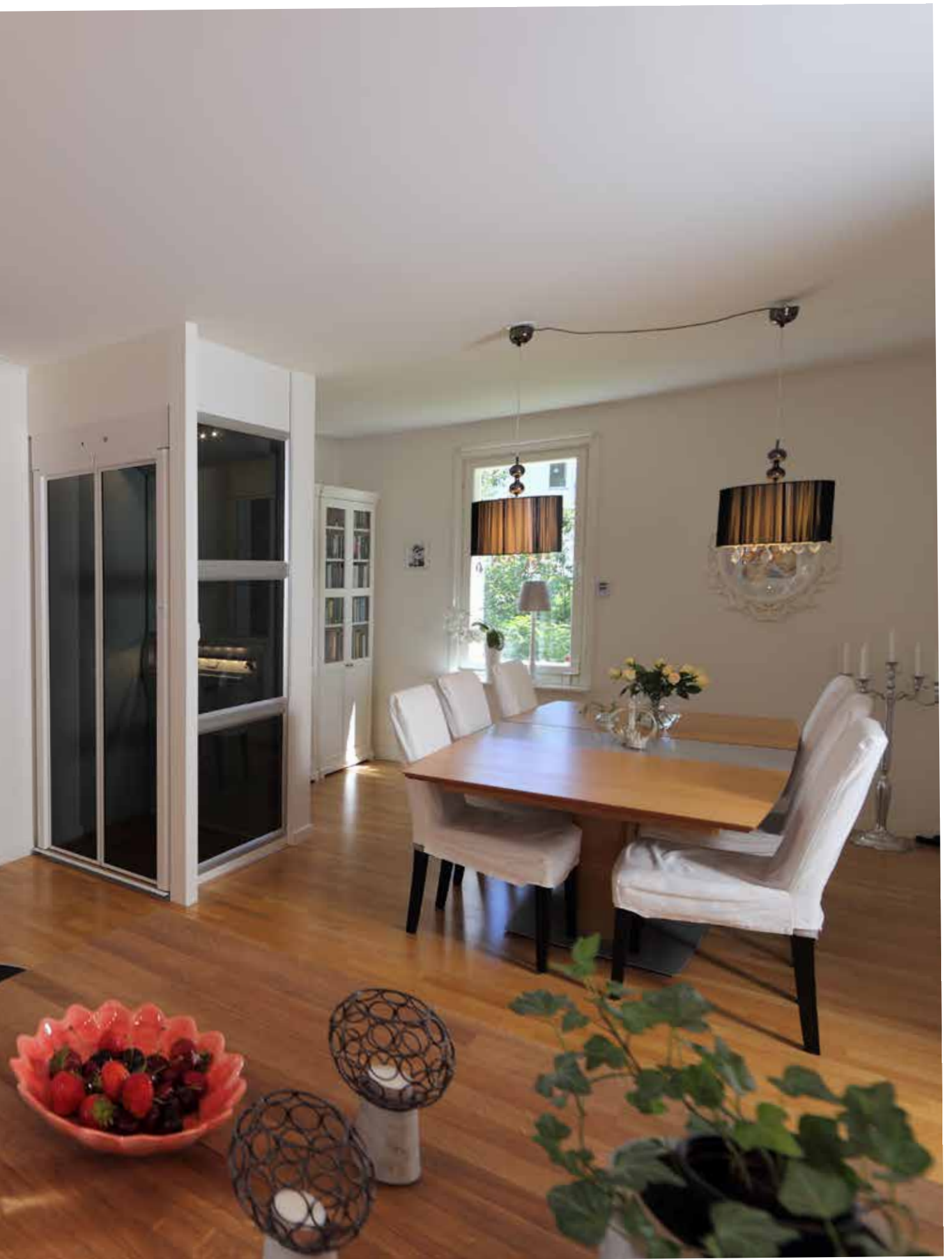

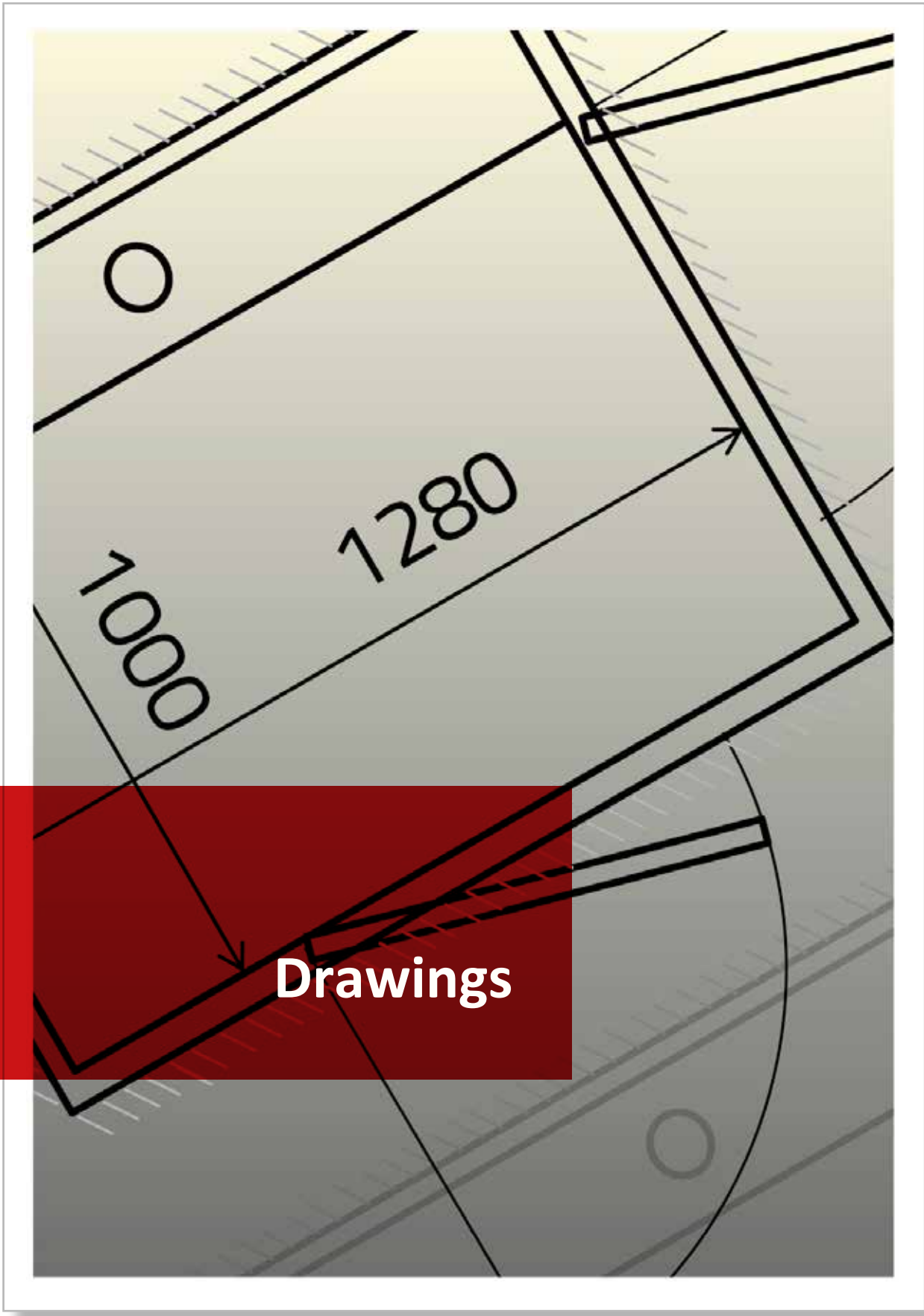

Platform 1080 × 805

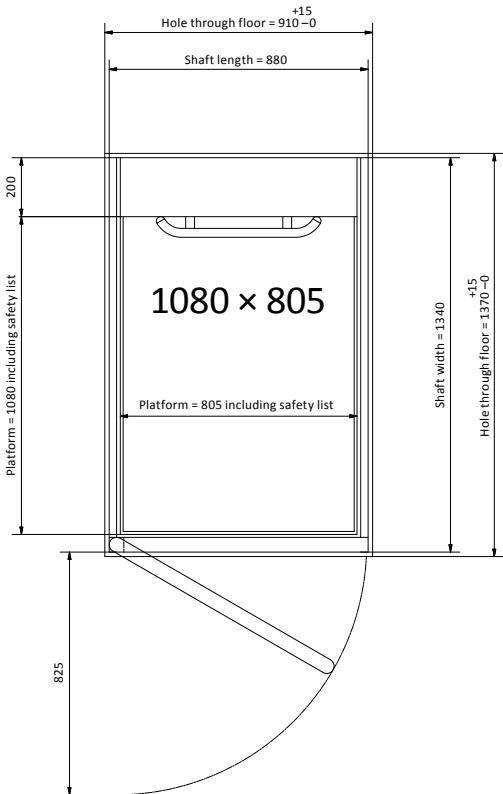
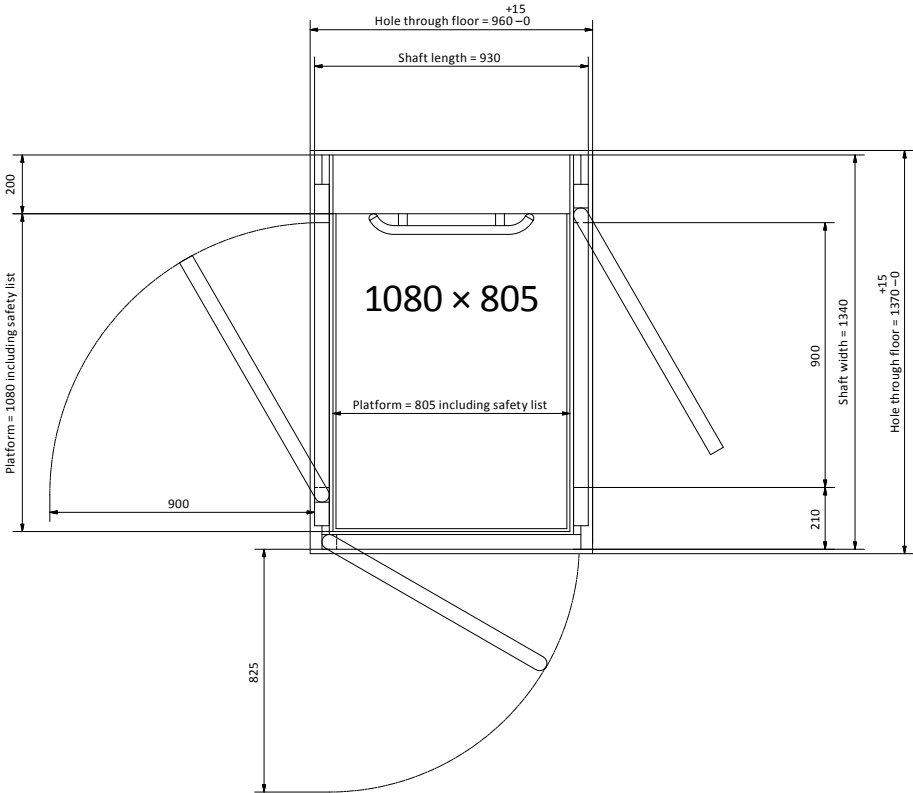

Platform 900 x 1040

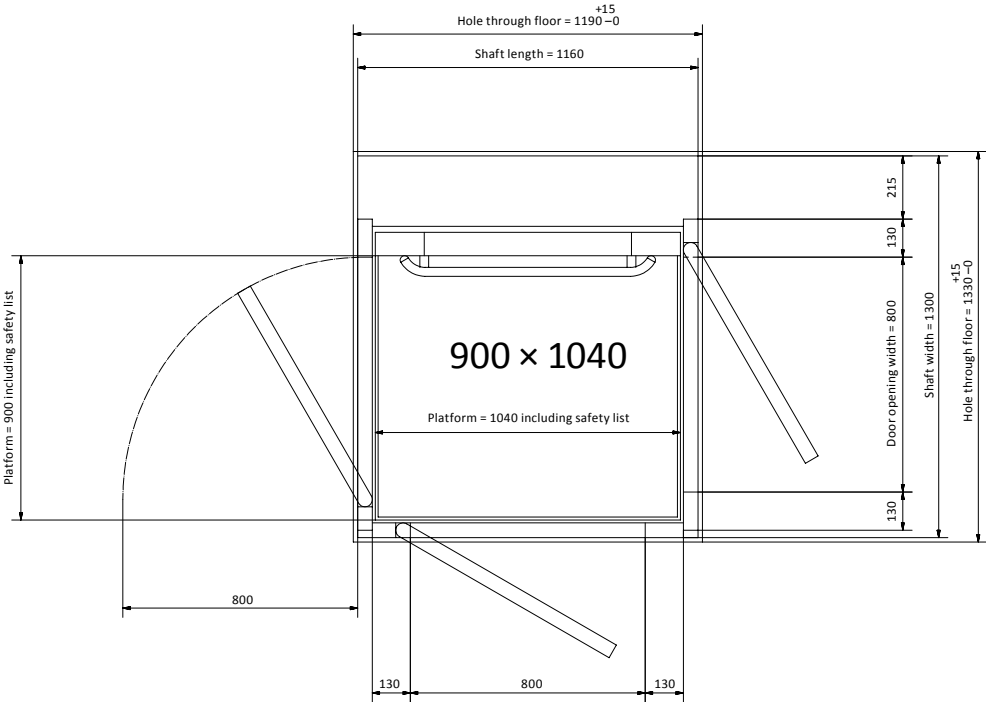
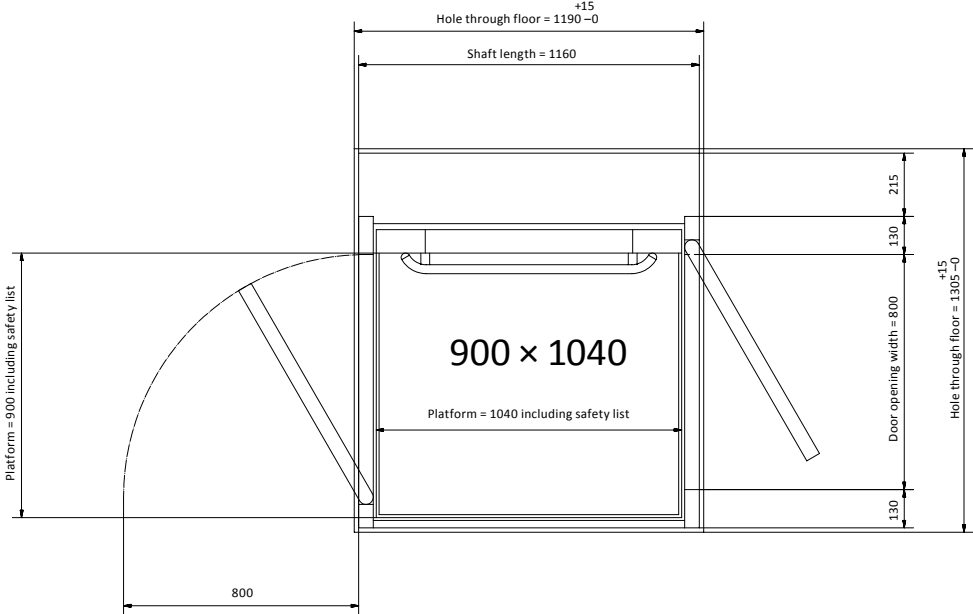

Platform 900 × 1280

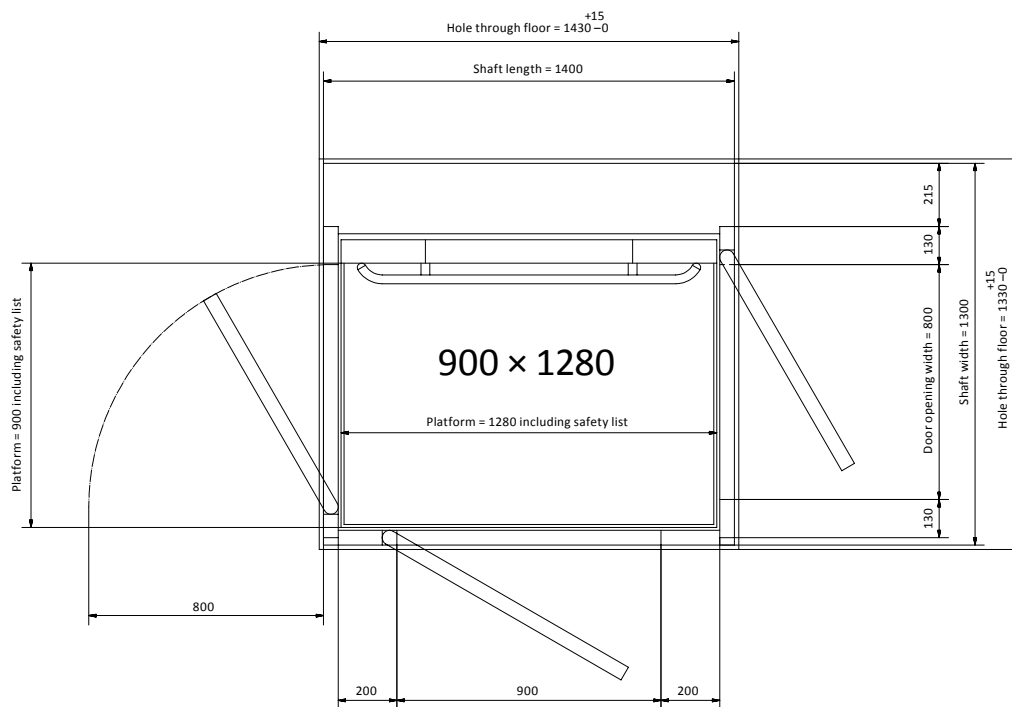
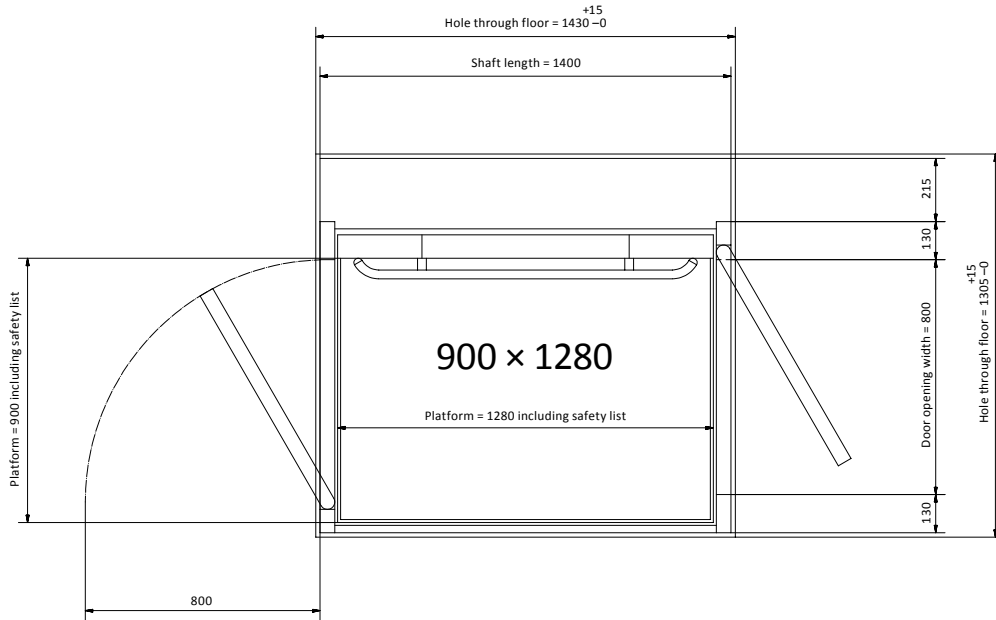

Platform 900 x 1480

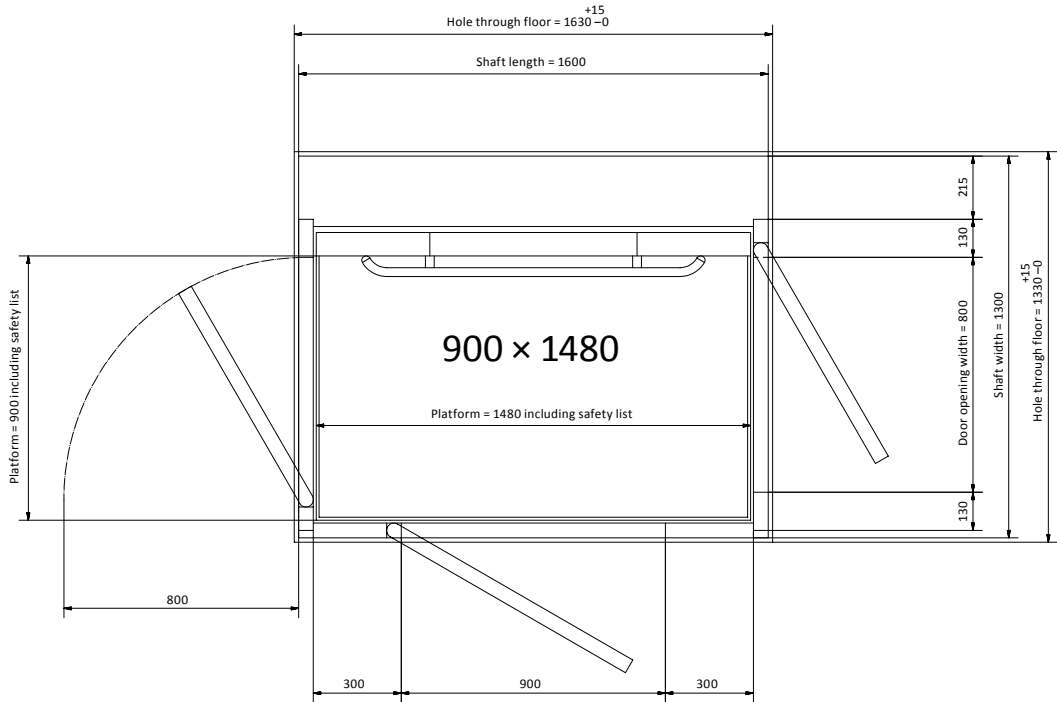
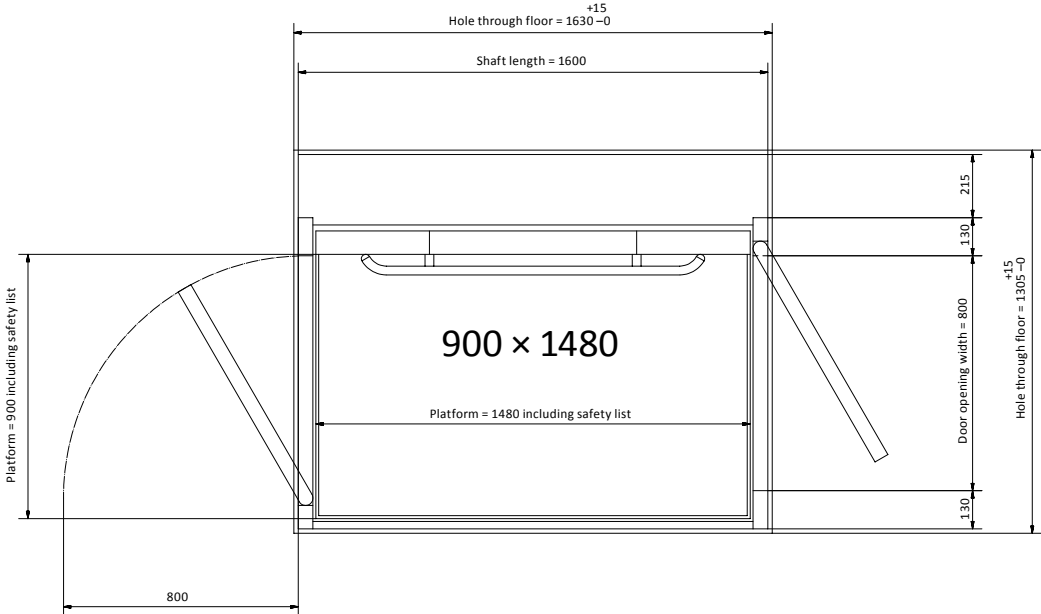

Platform 1000 × 1280

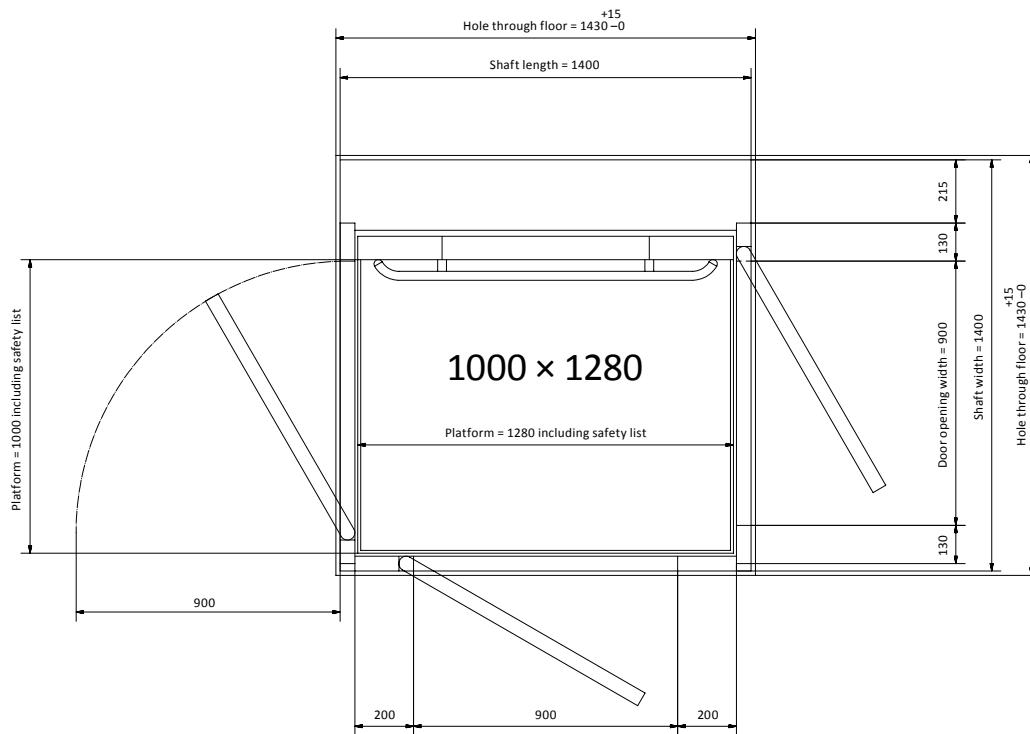
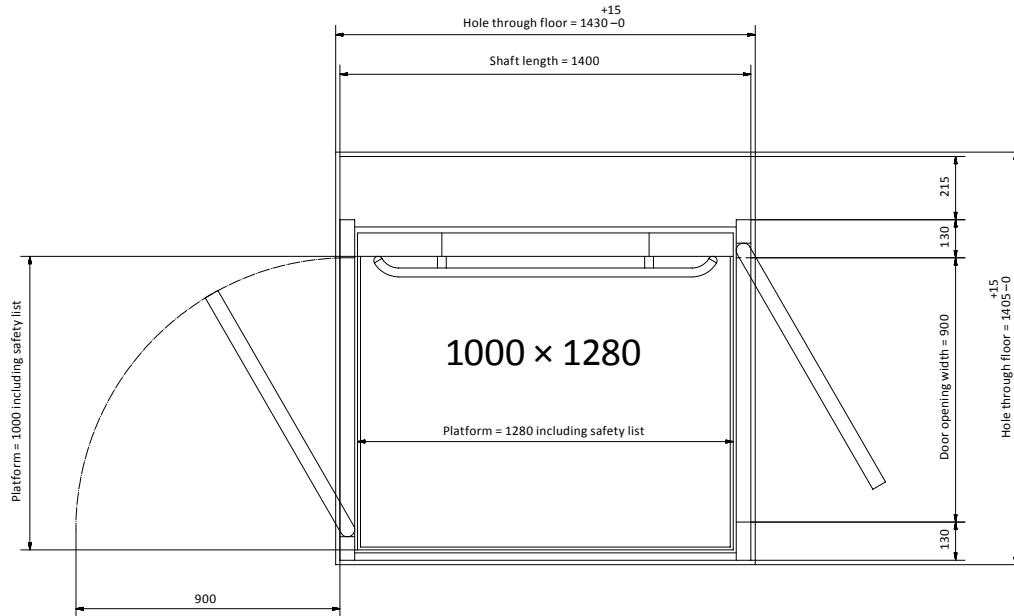

Platform 1000 × 1480

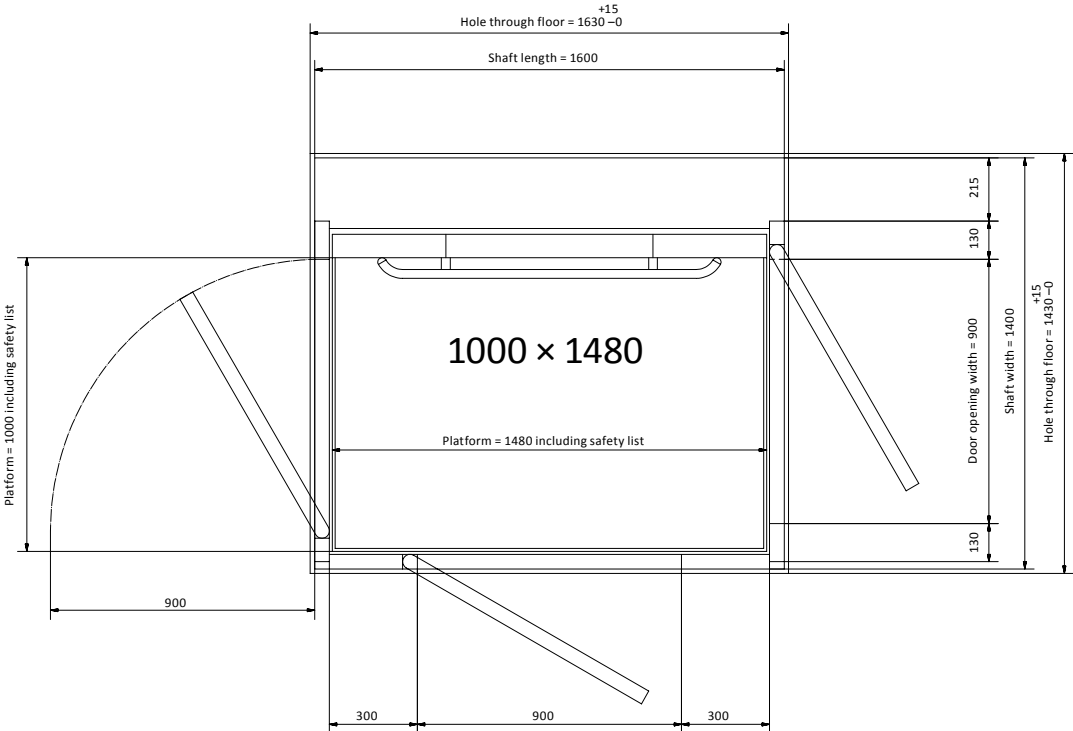
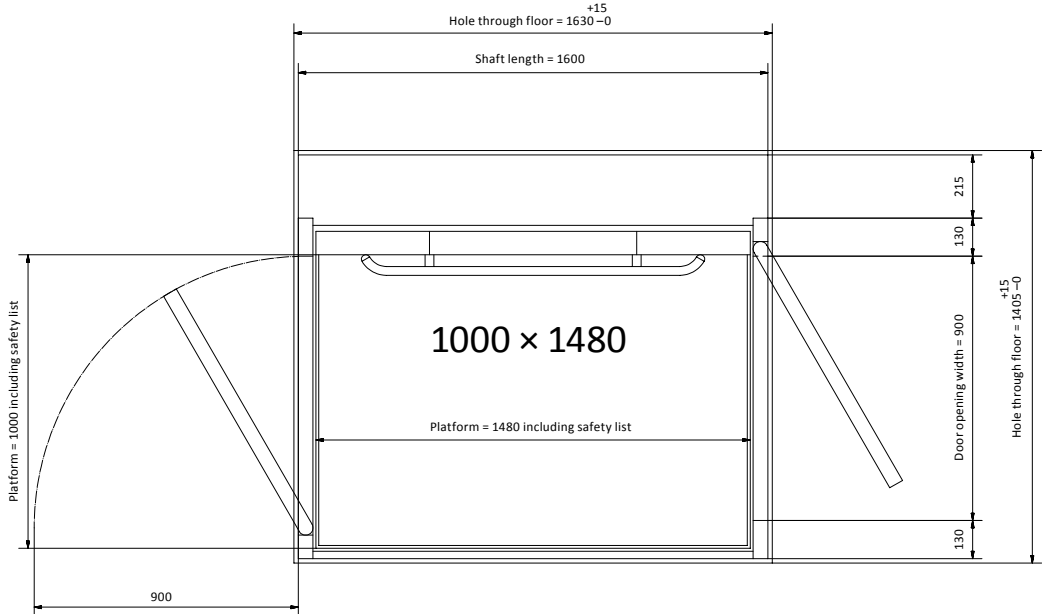

Platform 1100 × 1480

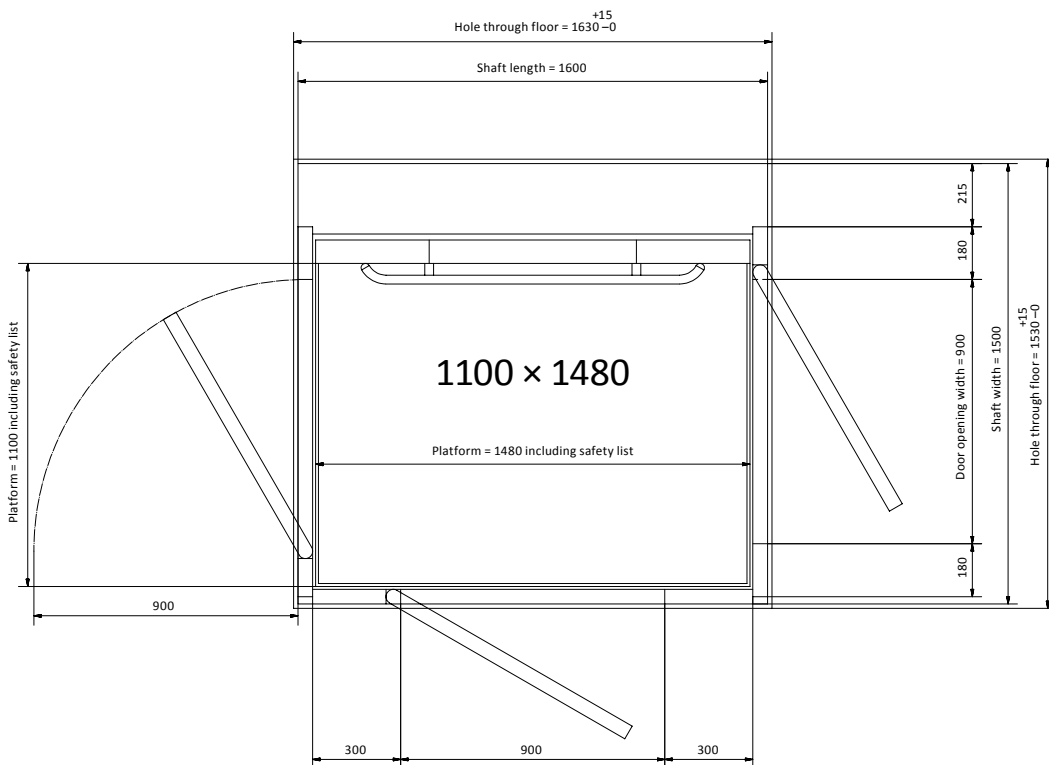
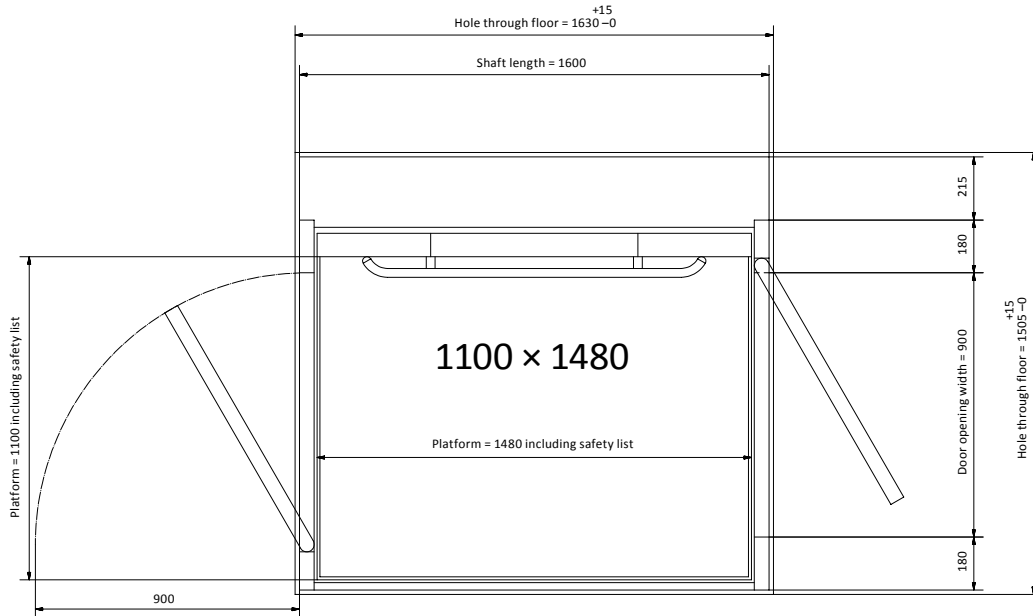

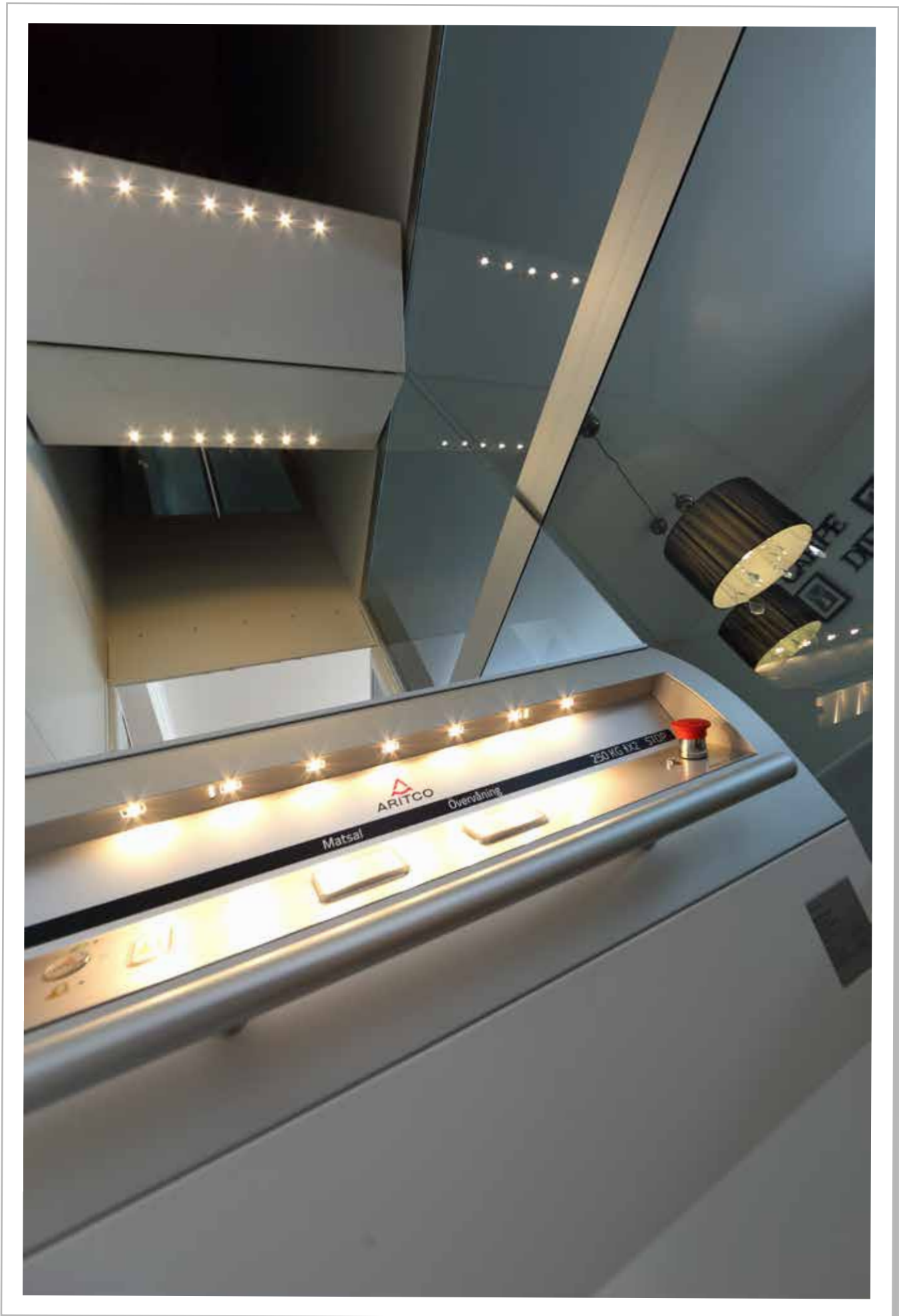



1. Can I have the lift painted in any colour?

Both Aritco 4000 and Aritco 6000 can be painted in any RAL colour or Metallic colour silver. Following choices are available:

Whole lift painted in standard colour RAL 9003 (Aritco white):

- Whole lift painted in RAL 9003 except for the destination panels which are painted in RAL 7042 (Grey).

Whole lift painted in other colour:

- Whole lift painted in optional colour (Incl. shaft, doors and platform panels.)

Lift partially painted in different colours:

- Shaft in one colour (Incl. shaft panels, corner profiles, Architraves, etc.)
- All door blades in one colour.
- All door frames in one colour (Also includes the door faceplate.)
- Platform panels in one colour.
- One of the above choices or a combination of them.



Note that all doors must be painted in the same way. It is not possible to paint them differently.

Definition of Aritco white is RAL 9003 structure with gloss 20 (i.e. it is a matte colour). When ordering another RAL colour on the lift it will be with structure and with gloss 12.

Any RAL colour means in this case any RAL color from the 213 colour RAL chart K7 classic.

Common colours:

RAL 1015	RAL 7012	RAL 7047	RAL 9006	RAL 9016
RAL 3020	RAL 7016	RAL 8017	RAL 9007	
RAL 5002	RAL 7045	RAL 9005	RAL 9010	

Shorter lead time and lower price

Other colours:

Rest of the colours from RAL chart K7 classic
 Longer lead time and higher price

Note that only Metallic colour silver, gloss 100+/-5% is available for sale.

2. What is the standard glass for door and shaft?

For Aritco 6000 the standard glass of door and shaft is clear glass (JT0) and for Aritco 4000 it is tinted glass (JT16). For all lifts it is possible to choose any of the following glass types; clear (JT0), tinted (JT16), dark tinted (JT5) and frosted (JT23) glass. Note that for Aritco 4000 when choosing clear glass the screw will be seen from outside the lift.

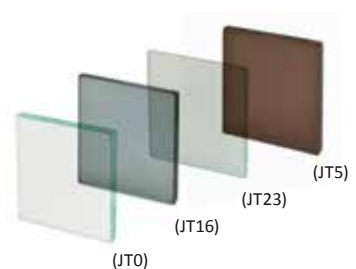

3. To which standards do the lifts comply?:

Aritco 4000 and Aritco 6000 comply with the Machine Directive 2006/42/EC, by following the harmonized standard EN 81-41. The lifts are also compliant with the Electromagnetic compatibility (EMC) – 2004 and Low voltage Directive 2006/95/EC. The lifts are type approved, CE marked. EI60 – Fire & smoke proof door complies with the lift directive 95/16/EC and EN 81-58.
 A certificate for respective lift is available on partner desktop.

4. What are the reaction forces on the building and force on fixings to support frame to wall?

Details regarding the forces are available in the installation manual for Aritco 4000 and Aritco 6000.

Aritco 6000

Reaction forces from the lift to the building:

- Maximum force as a function of the lift’s travel. The force is distributed to the floor through the mast bottom with the area “A” and to the shaft bottom with the area “B”.

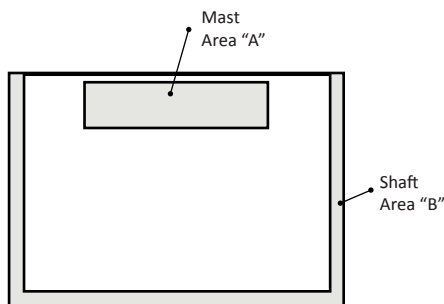

Travel height (m)	Area "A" F(kN)	Area "B" Shaft panels F(kN)	Area "B" Glass Shaft F(kN)
1	7,8	2,55	3,30
2	8,5	3,40	4,40
3	9,2	4,25	5,50
4	9,9	5,10	6,60
5	10,7	5,95	7,70
6	11,5	6,80	8,80
7	12,0	7,65	9,90
8	12,8	8,50	11,00
9	13,4	9,35	12,10
10	14,2	10,20	13,20
11	14,9	11,05	14,30
12	15,6	11,90	15,40

Force on fixing to support frame (mast) to wall:

- c - c = distance (height) from the floor to the highest fixing into the wall.
- The maximum distance between two fixings or lower floor and the lowest fixing is 4,0m.
- The minimum distance between lower floor and the highest fixing is 2,0 m.
- c - t = distance from the top of the mast to the highest fixing into the wall.
- The maximum distance between the top of the mast and highest fixing is 1,2 m

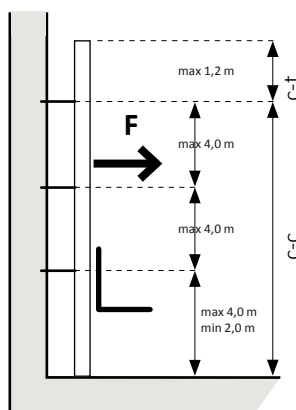

c-c (m)	F(kN) 410 kg load
2	1.5
3	1.0
4	0.8
5	0.6
6	0.5
7	0.4
8	0.5
9	0.3
10	0.3

Aritco 4000

Reaction forces from the lift to the building:

- Reaction forces on the lift to the building: Maximum force as a function of the lift’s travel. The force is distributed to the floor through the mast bottom with area “A” and the shaft bottom with the area “B”.

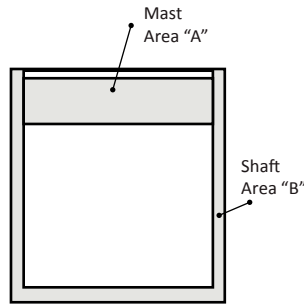

Travel (m)	F(kN)
2	3.9
3	4.1
4	4.2
5	4.4
6	4.5
7	4.7
8	4.8
9	5.0
10	5.2
11	5.3
12	5.5

Force on fixing to support frame (mast) to wall:

- c - c = distance (height) from the floor to the highest fixing into the wall.
- The maximum distance between two fixings or lower floor and the lowest fixing is 4.0 m.
- The minimum distance between lower floor and the highest fixing is 2.0 m.

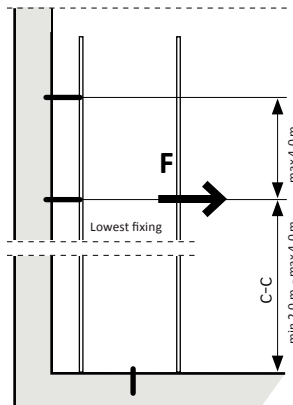

c-c (m)	F(kN) 225 kg load
2	0.84
3	0.56
4	0.42
5	0.34
6	0.28
7	0.24
8	0.21
9	0.19
10	0.17

You can always get out of the lift by yourself

- If there is a power failure, you can always get out of the lift by yourself with battery operated emergency lowering. Use the platform buttons and the lift will take you to the closest lower floor and you can open the door and get out by yourself.

The lift can't fall down

- With the self locking concept, i.e the friction between screw and nut will prevent the lift from falling down. No additional brake system is needed.

Minimum builders work and small footprint

- The lift can be installed without a pit, with a ramp (or with a 50 mm pit without ramp).
- All parts are included in the shaft - no extra machine room or head room needed.

No hydraulics, which mean no leakage or smell

- No additional space needed for hydraulic unit.



Easy installation

- Means that the lift is both easy and fast to install. A normal installation only takes two days .

Low operation and maintenance cost

- Lowest on the market.

Robust shaft

- 25 mm shaft panels. Robust and resistant to damage.
- Good noise and acoustical isolation.

Environmental Product Declaration

- We are the first lift manufacturer with an Environmental Product Declaration
- More than 95% of the parts are recyclable.

Low energy consumption

- Minimum stand-by power consumption 15 W – not more than a computer or a TV.
- Energy class A as per VDI 4707.

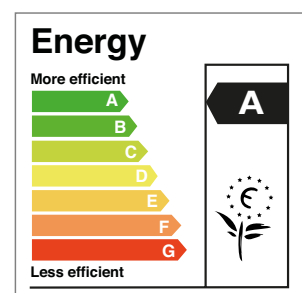

PRODUCT RANGE:

The purpose of this product catalogue is to show what Aritco can offer in terms of products, options and possible combinations. We have no possibility to deliver options that are not in the product catalogue.

Some highlights:

LEAD-TIME

Normal lead time for a standard Aritco 7000 is less than 3 weeks. For a standard Aritco 9000 the normal lead time is less than 6 weeks. During July and August, the lead-time can be slightly higher. Some options have a longer lead time – which is clearly communicated in the ordering system AOS and the price list. Note that it is always the order confirmation that states the final delivery time.

95% DELIVERY ACCURACY OF PRODUCTS

During more than 4 years, we have had a delivery accuracy of more than 95%, i.e. we have delivered within the agreed delivery week.

DELIVERY ACCURACY OF SPARE PARTS

If the spare part order is received before 2.00 p.m. the aim is to deliver the same day. Again – for more than 4 years we have had an accuracy of more than 95%.

ARITCO PARTNER DESKTOP

Our web site www.aritco.com is the centre for all our information and communication. Make sure you have a log-in to the Partner Desktop. If you do not have one, just contact your sales representative. On the Partner Desktop you will find, among others, this product catalogue, pricelists, technical documentation, picture gallery, news etc – always up to date.

TRANSPORT, PACKAGING AND STORAGE

You have two options when it comes to shipping carrier;

- By Aritco, due to agreement – (we book the shipping)
- Not by Aritco – (you take care of the shipping yourself)

Depending on how you are going to transport your lift, the lift can be packed in different ways.

Packing for shipping method:

- By trailer (worldwide)
- By boat in container without crate FCL¹⁾
- By boat and container with crate LCL¹⁾
- By air-freight in crate

¹⁾FCL means Full Container Load and LCL means Less Container Load.

Transport of several lifts at the same time:

- When you already know from the time that you order the lifts that you like to transport several lifts together, you must request the lifts to be produced in the same production week. Choose the production week for the lift with the longest lead time.
- If you don't know at the time of ordering the lift that you like to transport several lifts at the same time, you need to let us know latest 10 days before planned production week that you like to transport several lifts together. We will then look on the feasibility of doing this, and it is of course easier to make changes the sooner we get this request.

We have no room to store finished lifts. Thus when placing your order you must be sure of the delivery date so that you can ship the lift as soon as it leaves our production line. Storage cost according to the price list will be added.

ORDER AND CANCELLATION

It is only possible to order a complete lift in the AOS. If additional parts are needed they can be ordered as spare parts (such as shaft panels, keys etc.).

Orders with more than 10 days left until the start of promised production week:

These orders can be changed. The procedure is that you cancel the order and then place a new one. The downside is that you get a new order number and we cannot guarantee that you get the same slot. Since the material has already been ordered there will be a cancellation fee depending on the material involved.

Orders with less than 10 days left until the start of the promised production week:

For these orders, it is unfortunately too late to make changes. Too many processes are by then already initiated, and we have no time to fill this slot with another lift. If your customer wants to change the travel height or to change a door hinge, you should contact our After Sales Dept who may be able to help you.

Overview Aritco 4000

580 x 805

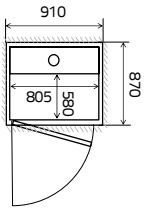

Hole through floor: 870x910 mm
Platform: 580x805 mm
Load: 250 kg

880 x 805

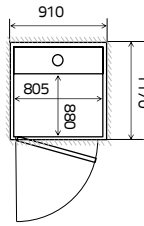

Hole through floor: 1170x910 mm
Platform: 880x805 mm
Load: 250 kg

1080 x 805

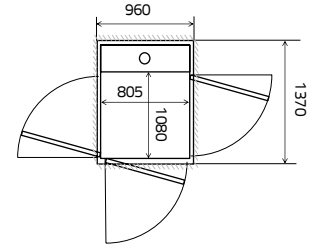

Hole through floor: 1370x960 mm
(No door on A/C side: 1370x910)
Platform: 1080x805 mm
Load: 250 kg

Overview Aritco 6000

900 x 1040

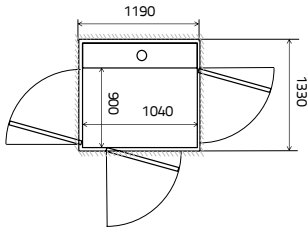

Hole through floor: 1330x1190 mm
(No door on B-side: 1305x1190)
Platform: 900x1040 mm
Load: 250 kg

900 x 1280

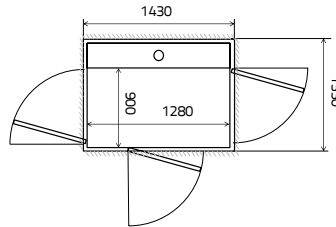

Hole through floor: 1330x1430 mm
(No door on B-side: 1305x1430)
Platform: 900x1280 mm
Load: 410 kg

900 x 1480

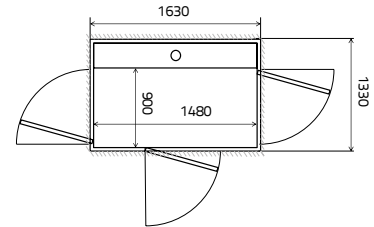

Hole through floor: 1330x1630 mm
(No door on B-side: 1305x1630)
Platform: 900x1480 mm
Load: 410 kg

1000 x 1280

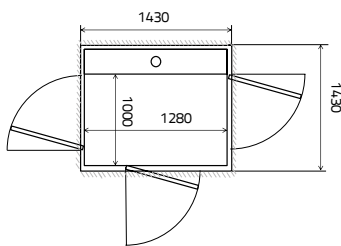

Hole through floor: 1430x1430 mm
(No door on B-side: 1405x1430)
Platform: 1000x1280 mm
Load: 410 kg

1000 x 1480

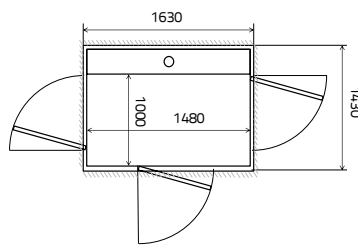

Hole through floor: 1430x1630 mm
(No door on B-side: 1405x1630)
Platform: 1000x1480 mm
Load: 410 kg

1100 x 1480

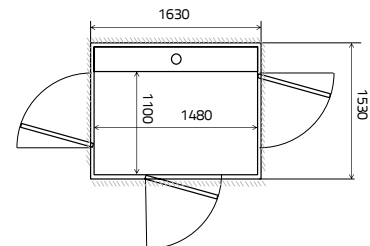

Hole through floor: 1530x1630 mm
(No door on B-side: 1505x1630)
Platform: 1100x1480 mm
Load: 410 kg



Aritco is a world-leading manufacturer of platform lifts and home lifts. It has around 100 employees and sales of approximately SEK 350 million. Aritco produces two types of lifts; home lifts for the private residential market and platform lifts for the public accessibility market. Read more at www.aritcohomelifts.com/4000-6000

Certified partner:



Only Lifts™

Only Lifts Ltd

01424 733767

aritco@onlylifts.com

www.onlylifts.com

