



LED FILAMENT 04/2017

SEGGULA

UNSERE VISION

Seit der Gründung des Unternehmens im Jahr 2007 steht die Marke SEGULA für Innovation, Premium-Qualität und zeitlose Ästhetik. Diese Grundlagen bestimmten von Beginn an auch die Entwicklung unseres exklusiven Leuchtmittel-Sortiments.

Die klassische Glühlampe ist für viele Menschen der Inbegriff von „gutem“ Licht. Mit ihrem gleichmäßigen Spektrum, der warmen Lichtfarbe und der natürlichen Wiedergabe aller Farben kommt sie der Abendstimmung bei natürlichem Sonnenlicht sehr nahe. Doch schon im Jahr 2005 verbannten die ersten Staaten Glühlampen wegen ihres hohen Energieverbrauchs – inzwischen mussten sie in fast allen Regionen der Welt energiesparenden Alternativen weichen. Leider konnten die meisten Alternativen dem „Original“ bisher weder qualitativ noch optisch das Wasser reichen.

Mit SEGULA-Lampen bringen wir den Menschen das angenehme, warme Licht der Glühlampe zurück. Ohne Kompromisse bei Farbwiedergabe, Qualität und Optik – mit energiesparender, langlebiger LED-Technik. Unser Ziel ist die bestmögliche Ökobilanz – durch den sparsamen Einsatz möglichst traditioneller Materialien, durch die Vermeidung gesundheitsschädlicher Substanzen und durch die Ermöglichung geschlossener Recycling-Kreisläufe. Ersetzen Sie Glühlampen, Halogenstrahler und Energiesparlampen durch hocheffiziente und ressourcenschonende SEGULA LED-Leuchtmittel. Gemeinsam leisten wir so einen Beitrag, unseren Kindern und Enkeln eine intakte Umwelt zu hinterlassen!

OUR VISION

Since the founding of the company in 2007, the brand name SEGULA has stood for innovation, premium quality and timeless aesthetics. These fundamentals have also defined the development goals of our exclusive range of light sources.

For most people the classical incandescent light bulb is the epitome of superior artificial light. With its even light spectrum, the warm light colour and the faithful reproduction of all colours it comes very close to the evening mood in natural sunlight. But already in 2005 the first states banned incandescent lamps because of their high energy consumption – now they had to be replaced by energy-saving alternatives in almost all regions of the world. Unfortunately, most alternatives can't hold a candle to the „original“ – neither optically, nor in terms of quality.

With SEGULA lamps we give people back the pleasant, warm light of the incandescent bulb. Without compromising colour reproduction, quality and appearance – with energy-saving, long-life LED technology. Our goal is the best possible environmental performance – through the careful use of traditional materials as possible, by avoiding harmful substances and by enabling closed recycling loops.

Replace incandescent bulbs, halogen lamps and energy saving lamps with highly efficient and resource-saving SEGULA LED lamps. Thus together we can contribute to preserve a healthy environment for our children and grandchildren!



LED FILAMENT TECHNOLOGIE

Bereits 2009 präsentierte SEGULA eine Revolution: Die erste LED-Retrofit-Lampe in der Bauform einer Original-Glühlampe. Ohne Abstriche an Optik und Abstrahlcharakteristik wurde damit erstmals ein 1:1-Ersatz von Glühlampen durch modernste LED-Technik möglich. Im Jahr 2013 kehrte das warme Licht historischer Kohlefilamentlampen mit unserer LED-„Vintage“-Serie zurück.

Das Herstellungsverfahren der SEGULA-Filament-Lampen ist international patentiert. Es ermöglicht die Fertigung einer langlebigen, mit Edelgas gefüllten LED-Lampe auf Produktionsanlagen für traditionelle Glühlampen unter Verwendung bewährter, reiner Materialien wie Glas und Metall. Durch unsere langjährige Erfahrung und ein ausgefeiltes Wärme-Management können wir sowohl auf störende Kühlkörper als auch auf Kunststoff-Teile verzichten – das führt zum äußerst geringen Gewicht unserer Filament-Lampen.

Vertrauen Sie der führenden Marke mit der längsten Erfahrung bei der Fertigung von LED-Leuchtmitteln auf Produktionsanlagen für traditionelle Glühlampen.

LED FILAMENT TECHNOLOGY

Already in 2009 SEGULA presented a revolution: The first LED retrofit lamp in the shape of an original incandescent bulb. For the first time the replacement of incandescent bulbs by the latest LED technology became possible without any sacrifice regarding design and the characteristics of light distribution. In 2013, the warm glow of historical carbon filament lamps returned with our LED „Vintage“ series.

The special production process of the SEGULA Vintage line is patented internationally. It enables us to produce a durable LED lamp filled with inert gas, on production lines for traditional bulbs using proven, pure materials such as glass and metal. Through our years of experience and a sophisticated thermal management we can dispense both disturbing heatsink as well as plastic parts – which leads to the extremely low weight of our filament lamps.

Trust the leading brand with the longest experience in the manufacture of LED bulbs on production facilities of traditional light bulbs.

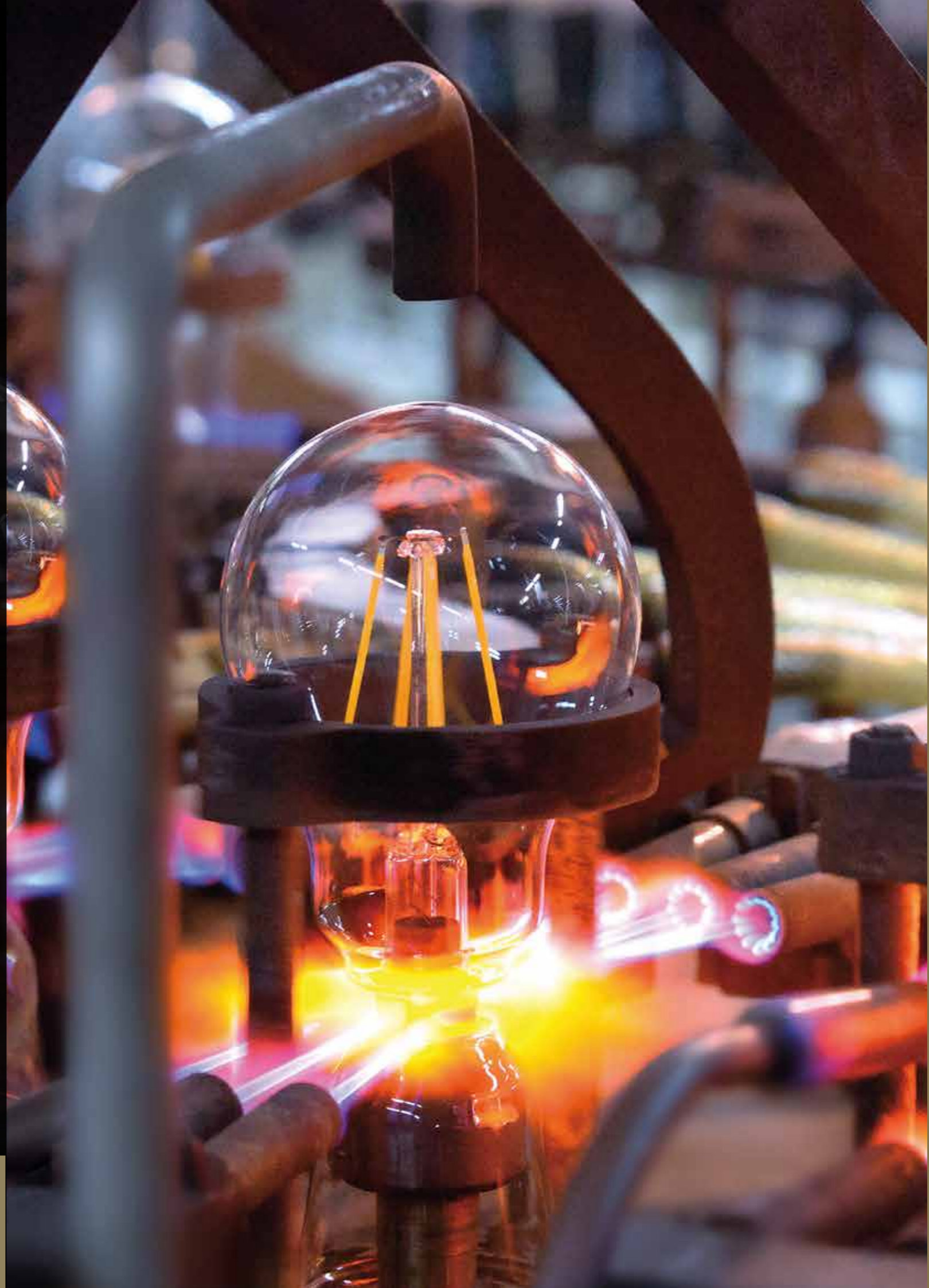

LED FILAMENT TECHNOLOGIE

Miniaturisierte LED-Chips und High-Tech-Trägermaterialien ermöglichen heute die Fertigung von filigranen, lichtstarken „Chip on Cord“-Filamenten (COC), die traditionellen Glühfäden gleichen – und ebenso warmes Licht mit höchster Farbwiedergabequalität abstrahlen. SEGULA LED-Filamente werden unter Verwendung der besten verfügbaren Materialien, wie taiwanesischer Marken-LED-Chips und Saphir als Träger hergestellt. Auch für unsere Spots setzen wir miniaturisierte LED-Chips in kompakter „Chip on Board“-Anordnung (COB) ein und erzielen damit eine Halogen-Spots zum Verwechseln ähnliche Optik und Abstrahlcharakteristik.

Die Reduktion auf wenige, sorgfältig ausgewählt Elektronik-Bauteile höchster Qualität optimiert Material- wie Energieeffizienz und ermöglicht die äußerst hohe Schaltfestigkeit. Ein weiterer Vorteil unseres besonderen Schaltungskonzeptes ist die geringe Flimmerneigung auch im gedimmten Zustand, so werden „Stroboskop-Effekte“ sicher vermieden.

LED FILAMENT TECHNOLOGY

Miniaturized SMD-LED-chips and high-tech carrier-material now permit the assembly of „Chip on Cord“ LED-filaments (COC) with high luminous intensity, warm colour and highest colour rendering, that just look like tungsten filaments. SEGULA LED filaments are produced using the best materials available, such as Taiwanese brand LED chips and sapphire as carrier. Also for our spots we are using miniaturized LED chips in a compact „chip on board“ arrangement (COB) and thus achieve a halogen spots confusingly similar optics and light distribution.

The reduction to a few carefully selected electronic components of highest quality optimises material as energy efficiency and allows for extremely high switching capability. Another advantage of our special circuit concept is the low flicker rate - also in dimmed state, so „stroboscopic effects“ can be certainly avoided.



- **Lange Lebensdauer (bis zu 20.000 Std.)**
Long lifetime (up to 20,000 hours)
- **Höchste Energie-Effizienz (A bis A++)**
Highest Energy Efficiency (A to A++)
- **Hervorragende Ökobilanz**
Excellent ecological performance
- **Frei von Quecksilber**
Free of mercury
- **Keine UV Emission**
No UV emission
- **360° Rundum-Abstrahlung**
360 ° all-around light distribution
- **Höchste Lichtausbeute (bis 130 Lumen/Watt)**
Highest luminous efficacy (up to 130 lumens/watt)
- **1:1-Ersatz herkömmlicher Glühlampen**
1:1 replacement of conventional incandescent bulbs
- **CRI90 Unverfälschte Farbwiedergabe feinsten Farbnuancen**
CRI90 Faithful reproduction of even the finest colour-nuances
- **Angenehme Farbtemperatur (2000-2900 Kelvin)**
Pleasant color temperature (2000-2900 Kelvin)
- **Höchste Ästhetik durch filigrane LED-Elemente**
Highest aesthetics by filigree LED filaments
- **Geringes Gewicht – wie Glühlampen**
Light weight - such as light bulbs

PRODUKTLINIEN

Die große Vielfalt an Bauformen, Sockeln, Glasvarianten und Lichtstärken ist eine weitere Stärke der SEGULA LED Leuchtmittel. Mit ihren kompakten Abmessungen – genau wie die Original-Glühlampen und Halogen-Spots – passen sie in alle handelsüblichen Leuchten und schaffen ganz neue Einsatzfelder für energie-effiziente und zugleich elegante Lichtlösungen.

Auch die Abstrahlcharakteristik entspricht genau der jeweiligen Vergleichstypen. Und durch die spezielle Anordnung der Filamente bieten SEGULA-Lampen eine bis zu 360° reichende Rundum-Abstrahlung – das vermeidet störende Abschattungen auf Lampenschirmen.

In unseren 4 Produktlinien finden Sie für jede Anwendung die passende Lampe – und ganz sicher auch Ihren ganz persönlichen Favoriten! Ein breites Sortiment an passendem Zubehör rundet das SEGULA-Sortiment ab.

PRODUCT LINES









The great variety of designs, sockets, glass variants and luminous outputs is another strength of SEGULA LED bulbs. With their compact dimensions – just like the original incandescent lamps and halogen spots – they fit into all conventional fittings and create entirely new applications for energy-efficient and elegant lighting solutions.

The light distribution corresponds exactly to the respective comparison type.

And with their special arrangement of the filaments SEGULA lamps provide up to 360° all-around light distribution – thus avoiding disturbing shadows on lamp shades.

In our 4 product lines you will find the right lamp for every application – and certainly your personal favorite! A wide range of matching accessories completes the SEGULA assortment.

PRODUCT LINES

DESIGN LINE		SMOKEY STYLE CURVED STYLE	CURVED, SMOKEY dimmable CRI 90	
VINTAGE LINE		GOLDEN STYLE STANDARD STYLE	2.200 / 2600 Kelvin dimmable CRI 90	
AMBIENT LINE		AMBIENT DIMMING	Ambient Dimming 2.000 - 2.900 Kelvin CRI 90	
CLASSIC LINE		STANDARD STYLE GOLDEN STYLE	2.700 Kelvin Not dimmable	
XTRA LINE		DIMMING PENDANT LIGHTS	Pendelleuchten Dimmer Pendel-Sets	

DESIGN LINE

VINTAGE LINE

AMBIENT LINE

CLASSIC LINE

XTRA LINE

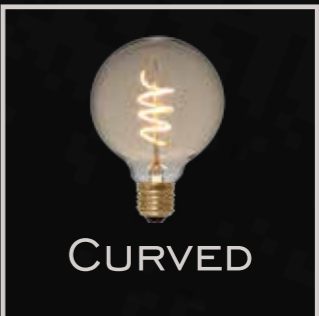

DESIGN SERIE

Mit den brandneuen Lampen der Serie „Curved Line“ bringt SEGULA eine weitere Innovation: Die flexiblen LED-Filamente sehen Glühfäden zum Verwechseln ähnlich und eignen sich mit ihrem warmen, blendfreien Licht ideal für dekorative Beleuchtungszwecke. Das dezent getönte Glas der „Smokey Line“ sorgt für ganz besondere, weiche Beleuchtungseffekte! Diese Lampen bestechen schon vor dem Einschalten durch ihre einzigartige Optik – und verzaubern beim Einschalten mit einer unvergleichlich warmen Lichtatmosphäre.

Alle Lampen der Segula Design-Linie sind voll dimmbar, sie zeichnen sich durch Ihre warme Farbtemperatur von 2200 Kelvin und den besonders hohen Farbwiedergabe-Index (CRI) von >90 aus!

DESIGN LINE

With the brand new lamps of the „Curved Line“ range SEGULA introduces another innovation: The flexible LED filaments look deceptively similar to glow wires and with their warm, glare-free illumination they are ideally suited for decorative lighting purposes.

The subtly tinted glass of „Smokey Line“ provides very special, soft lighting effects! With their unique look these lamps impress even when switched off – and when switched on enchant with an incomparably warm light atmosphere.

All lamps of the SEGULA Design line are fully dimmable and come with the particularly high colour rendering index (CRI) of >90 and a colour temperature of 2200 Kelvin.

CRI
90

+35C
to
-20C

Hg
NO
MERCURY

SAVE UP TO
90%
ENERGY

ON / OFF
100.000

LIFETIME
20.000h



HELLIGKEIT
BRIGHTNESS

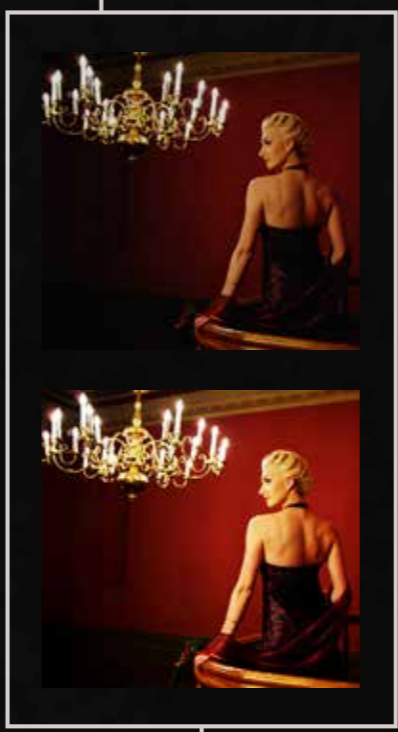



Beer Bulb™

CURVED
BEER BULB

LED BEER BULB Curved Spirale klar **NEW**

LED Beer Bulb Curved Spiral clear

klar / clear

50121

6



E27

CRI 90

4W

12W

120 Lm

2200 K

B



Ø = 75 mm

l = 250 mm

LED BEER BULB Curved Spirale braun **NEW**

LED Beer Bulb Curved Spiral brown

braun / brown

50122

6



E27

CRI 90

4W

10W

100 Lm

2000 K

B



Ø = 75 mm

l = 250 mm

LED BEER BULB Curved Spirale grün **NEW**

LED Beer Bulb Curved Spiral green

grün / green

50123

6



E27

CRI 90

4W

10W

100 Lm

2000 K

B



Ø = 75 mm

l = 250 mm



CURVED
LINE

LED Rustika Curved gold

LED Rustica Curved golden

GOLD GOLDEN



50530
24



E27
CRI 90

2,7W
9W

90 Lm
2200 K

Ø=60 mm
l=135 mm

LED Rustika Curved Loop gold

LED Rustica Curved Loop golden

GOLD GOLDEN

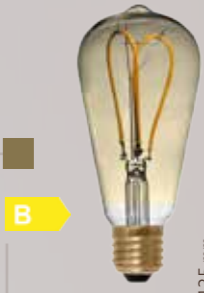

50531
24



E27
CRI 90

4,0W
15W

140 Lm
2200 K

Ø=60 mm
l=135 mm

LED Rustika Curved Spirale grau

LED Rustica Curved Spiral grey

GRAU GREY

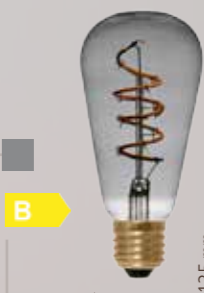

50532
24



E27
CRI 90

4,0W
12W

120 Lm
2200 K

Ø=60 mm
l=135 mm

LED Rustika Curved Spirale klar NEW

LED Rustica Curved Spiral clear

Filament PLUS



50408
24



E27
CRI 90

6W
25W

250 Lm
2200 K

Ø=60 mm
l=135 mm



CURVED
LINE

LED Globe 80 Curved gold

LED Globe 80 Curved golden

GOLD GOLDEN

50523

12 20



E14
CRI 90

4,0W
15W

140 Lm
2200 K

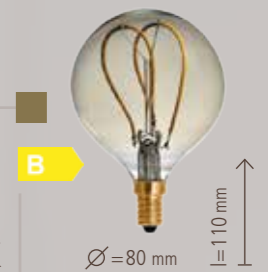

LED Globe 95 Curved gold

LED Globe 95 Curved golden

GOLD GOLDEN

50535

12 12



E27
CRI 90

4,0W
15W

140 Lm
2200 K

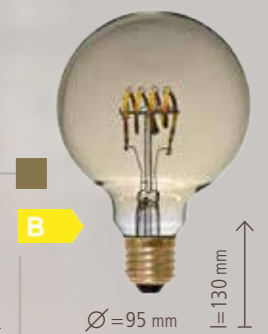

LED Globe 95 Curved Spirale gold

LED Globe 95 Curved Spiral golden

GOLD GOLDEN

50536

12 12



E27
CRI 90

4,0W
15W

140 Lm
2200 K



LED Globe 125 Curved gold

LED Globe 125 Curved golden

GOLD GOLDEN

50541

12 12



E27
CRI 90

4,0W
15W

140 Lm
2200 K

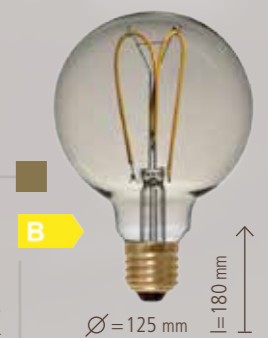



CURVED
LINE

LED Globe 95 Curved Point klar NEW

LED Globe 95 Curved Point clear

50166
12



E27
CRI 90

2,7W
9W

90 Lm
2200K

Filament PLUS

A



LED Globe 125 Curved Point klar NEW

LED Globe 125 Curved Point clear

50168
8



E27
CRI 90

2,7W
9W

90 Lm
2200K

Filament PLUS

A

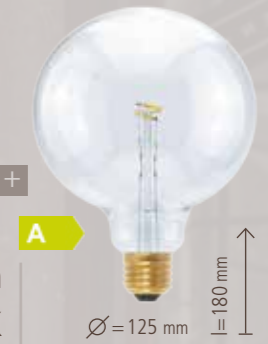

LED Globe 95 Curved Butterfly klar NEW

LED Globe 95 Curved Butterfly clear

50409
12



E27
CRI 90

8W
28W

300 Lm
2200K

Filament PLUS

B



LED Globe 125 Curved Butterfly klar NEW

LED Globe 125 Curved Butterfly clear

50415
8



E27
CRI 90

8W
28W

300 Lm
2200K

Filament PLUS

B



LED Globe 125 Curved Spirale klar NEW

LED Globe 125 Curved Spiral clear

50416
8



E27
CRI 90

8W
28W

300 Lm
2200K

Filament PLUS

B



CURVED
GRAND BULB



Fassung

Socket

E27

LED Grand Bulb Curved Spirale klar **NEW**

LED Grand Bulb Curved Spiral clear

Filament PLUS +

50792

8



E27
CRI 90

12W
45W

550 Lm
2200K



Fassung

Socket

E40

LED Grand Bulb Curved Spirale klar **NEW**

LED Grand Bulb Curved Spiral clear

Filament PLUS +

50788

6



E40
CRI 90

18W
65W

900 Lm
2200K





CURVED
ELLIPSE



Fassung
Socket

E27

LED Ellipse Curved U klar **NEW**

LED Ellipse Curved U clear

50797
8



E27
CRI 90

10W
40W

470 Lm
2200K

Filament PLUS



B



Ø=90 mm
l=225 mm

Fassung
Socket

E40

LED Ellipse Curved U klar **NEW**

LED Ellipse Curved U clear

50785
6



E40
CRI 90

18W
65W

900 Lm
2200K

Filament PLUS



B



Ø=118 mm
l=290 mm



CURVED

LED Kühlschranklicht Curved klar NEW

LED Fridge Lamp Curved clear

Filament PLUS +

A



50155
70 / 280



E14
CRI 90

2,2W
7W

70 Lm
2200 K

∅=26 mm

l=60 mm

LED Kerze Curved klar NEW

LED Candle Curved clear

Filament PLUS +

A



50158
24 / 96



E14
CRI 90

2,2W
7W

70 Lm
2200 K

∅=35 mm

l=98 mm

LED Kerze Curved klar

LED Candle Curved clear

A



50521
24 / 96



E14
CRI 90

2,7W
9W

90 Lm
2200 K

∅=35 mm

l=95 mm

LED Tropfenlampe Curved klar

LED Drop Lamp Curved clear

A



50522
12 / 48



E14
CRI 90

2,7W
9W

90 Lm
2200 K

∅=45 mm

l=108 mm

LED FILAMENT

SEGULA

CURVED

SEGULA
LED Vintage line

Yes, it's led!
Yes, it's dimmable!

SEGULA

LED Glühlampe klein Curved klar

LED Bulb small Curved clear

50525
8 / 48



E27
CRI 90

2,7W
9W

90 Lm
2200 K

A



Ø=45 mm
l=85 mm

LED Glühlampe Curved klar

LED Bulb Curved clear

50526
8 / 32



E27
CRI 90

4,0W
15W

140 Lm
2200 K

B



Ø=60 mm
l=108 mm

LED Radio Style Curved Spirale klar

LED Radio Style Curved Spiral clear

50527
8 / 32



E27
CRI 90

4,0W
15W

140 Lm
2200 K

B



Ø=45 mm
l=128 mm

LED Tube Curved Spirale klar

LED Tube Curved Spiral clear

50418
8 / 32



E27
CRI 90

8W
28W

300 Lm
2200 K

B



Ø=32 mm
l=185 mm

Filament PLUS





SMOKEY

© PSM Lighting

LED Rustika Smokey grau

LED Rustica Smokey grey

GREY GRAU

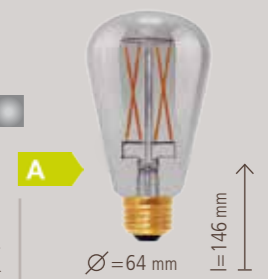

50500
🏠 24



E27
CRI 90

6,0W
25W

250 Lm
2000K

A

Ø = 64 mm
l = 146 mm

LED Globe 125 Smokey grau

LED Globe 125 Smokey grey

GREY GRAU



50503
🏠 8



E27
CRI 90

6,0W
25W

250 Lm
2000K

A

Ø = 125 mm
l = 180 mm

LED Globe 125 Smokey grün

LED Globe 125 Smokey green

GREEN GRÜN

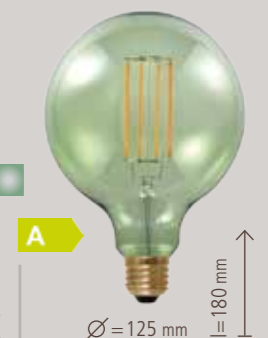

50504
🏠 8



E27
CRI 90

6,0W
30W

325 Lm
2000K

A

Ø = 125 mm
l = 180 mm

LED Globe 125 Smokey pink

LED Globe 125 Smokey pink

PINK ROSA



50505
🏠 8



E27
CRI 90

6,0W
30W

325 Lm
2000K

A

Ø = 125 mm
l = 180 mm

VINTAGE SERIE

Die Vintage-Serie war vom Start weg unser Bestseller – sie kombiniert die traditionelle Bauform sowie die unvergleichliche Lichtatmosphäre historischer Kohlefadenlampen und klassischer Glühlampen mit hocheffizienter, voll dimmbarer High-End LED-Technik. Die Farbtemperatur von 2200 Kelvin zaubert ein Ambiente ähnlich natürlichem Kerzenlicht, unsere Lampen mit 2600 Kelvin eignen sich ideal für den gesamten Wohnbereich. Der besonders hohe Farbwiedergabe-Index (CRI) von >90 und das äußerst gleichmäßige Spektrum sorgen für die unverfälschte Wiedergabe auch feinsten Farbnuancen. Erleben Sie den Unterschied! Alle Lampen der SEGULA Vintage-Serie sind voll dimmbar und lassen sich an einer Vielzahl handelsüblicher Dimmer betreiben.

Wählen Sie unter einer Vielzahl von Formen und Ausführungen von der Mini-Kerze über die Großkolbenlampe bis hin zur Linienlampe mit der Illusion eines durchgehenden Leuchtfadens – jede ist auf ihre Art ein kleines Kunstwerk.

VINTAGE LINE

The Vintage Line from day one was a bestseller – it combines the traditional look and feel as well as the incomparable lighting atmosphere of historical tungsten-filament lamps and of classic incandescent lamps with highly efficient, fully dimmable high-end LED technology. The colour temperature of 2200 Kelvin conjures an atmosphere similar to natural candlelight, our lamps with 2600 Kelvin are perfectly suitable for the entire living area. The particularly high colour rendering index (CRI) of >90 and the exceedingly even light spectrum provide for the faithful reproduction of even the finest colour-nuances. Experience the difference! All lamps of the SEGULA Vintage line are fully dimmable and compatible with virtually all dimming manufactures.

Choose among a variety of shapes and designs: From mini-candles up to globe lamps and linear lamps with a special LED-array giving the illusion of a continuous historic carbon filament. Each lamp in its own way is a unique design piece.



CRI
90

+35C
to
-20C

Hg
NO
MERCURY

SAVE UP TO
90%
ENERGY

ON / OFF
100.000

LIFETIME
20.000h



HELLIGKEIT
BRIGHTNESS

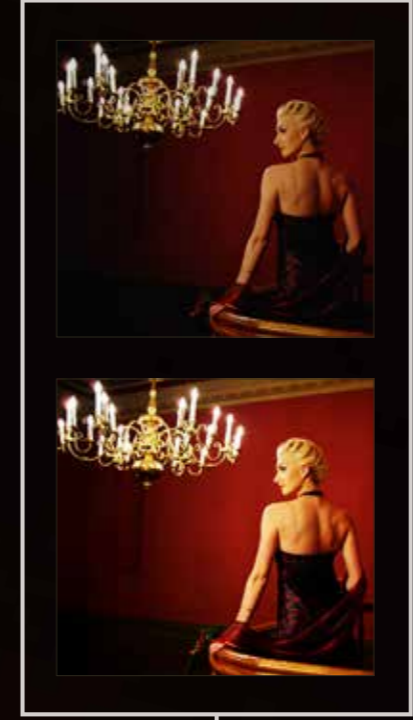

2.200 Kelvin

2.600 Kelvin



STANDARD



GOLDEN



RETRO



TUBE
LINEAR



LED Globe 80 klar
LED Globe 80 clear

50288
20



E27
CRI 90

6,0W
42W

500 Lm
2200 K



LED Globe 95 klar
LED Globe 95 clear

50282
12



E27
CRI 90

3,5W
20W

200 Lm
2200 K



LED Globe 95 klar
LED Globe 95 clear

50283
12



E27
CRI 90

6,0W
42W

500 Lm
2200 K



LED Globe 125 klar
LED Globe 125 clear

50286
8



E27
CRI 90

8,0W
50W

620 Lm
2200 K



LED Globe 95 opal
LED Globe 95 opal

50683
12



E27
CRI 90

4,0W
30W

320 Lm
2600 K



LED Globe 125 klar
LED Globe 125 clear

50685
8



E27
CRI 90

6,0W
40W

470 Lm
2600 K





LED Globe 80 gold

LED Globe 80 golden

GOLD GOLDEN

50291

20



E27

CRI 90

6,0W

30W

325 Lm

2000 K



∅ = 80 mm

l = 125 mm

LED Globe 95 gold

LED Globe 95 golden

GOLD GOLDEN

50292

12



E27

CRI 90

6,0W

30W

325 Lm

2000 K



∅ = 95 mm

l = 130 mm

LED Globe 125 gold

LED Globe 125 golden

GOLD GOLDEN

50293

8



E27

CRI 90

6,0W

30W

325 Lm

2000 K



∅ = 125 mm

l = 180 mm



© PSM Lighting

LED Rustika Long Style gold

LED Rustica Long Style golden

GOLD GOLDEN



50295
24



E27
CRI 90

6,0W
35W

400 Lm
2000 K

LED Rustika gold

LED Rustica golden



50296
24



E27
CRI 90

6,0W
40W

470 Lm
2000 K

LED Rustika Long Style klar

LED Rustica Long Style clear



50298
24



E27
CRI 90

6,0W
40W

470 Lm
2200 K

LED Rustika klar Long Style

LED Rustica clear Long Style



50700
24



E27
CRI 90

6,0W
40W

470 Lm
2600 K



© TIM MÄLZER Die gute Botschaft in Hamburg

LED Radio Style klar

LED Radio Style clear

50216
 12 / 48



E14
CRI 90

4,7W
 35W

400 Lm
 2200 K

A+



LED Radio Style klar

LED Radio Style clear

50215
 8 / 32



E27
CRI 90

4,7W
 35W

400 Lm
 2200 K

A+



LED Glühlampe klar

LED Bulb clear

50211
 12 / 48



E27
CRI 90

3,5W
 20W

200 Lm
 2200 K

A+



LED Glühlampe klar

LED Bulb clear

50278
 8 / 32



E27
CRI 90

6,0W
 40W

470 Lm
 2200 K

A+



LED Glühlampe matt

LED Bulb frosted

50335
 8 / 32



E27
CRI 90

8,0W
 55W

720 Lm
 2600 K

A+



LED Glühlampe klar

LED Bulb clear

50337
 8 / 32



E27
CRI 90

8,0W
 55W

720 Lm
 2600 K

A+





LED Glühlampe orange

LED Bulb orange

50671
 8 / 32



E27
CRI 90

2,0W

30 Lm



LED Glühlampe blau

LED Bulb blue

50672
 8 / 32



E27
CRI 90

2,0W

30 Lm



LED Glühlampe grün

LED Bulb green

50673
 8 / 32



E27
CRI 90

2,0W

30 Lm



LED Glühlampe rot

LED Bulb red

50674
 8 / 32



E27
CRI 90

2,0W

30 Lm





LED Kerze klar
LED Candle clear

50201
24 / 96



E14
CRI 90

3,5W
20W

200 Lm
2200K

A+



Ø=35 mm

l=98 mm

LED Kerze opal
LED Candle opal

50202
24 / 96



E14
CRI 90

3,5W
15W

150 Lm
2200K

A+



Ø=35 mm

l=98 mm

LED Kerze klar
LED Candle clear

50253
24 / 96



E14
CRI 90

4,0W
30W

320 Lm
2200K

A+



Ø=35 mm

l=98 mm

LED Kerze Windstoß klar
LED Candle Flame clear

50206
24 / 96



E14
CRI 90

3,5W
20W

200 Lm
2200K

A+



Ø=35 mm

l=112 mm

LED Kerze klar
LED Bulb clear

50341
24 / 96



E14
CRI 90

3,5W
25W

250 Lm
2600K

A+



Ø=35 mm

l=98 mm

LED Kerze klar
LED Candle clear

50313
24 / 96



E14
CRI 90

4,0W
33W

360 Lm
2600K

A+



Ø=35 mm

l=98 mm



© SAPROCO

LED Mini-Glühlampe klar

LED Mini-Bulb clear

50204
24 / 96



E14
CRI 90

2,2W
16W

160 Lm
2200 K

A+



LED Golfball klar

LED Golfball clear

50208
12 / 48



E27
CRI 90

2,7W
18W

180 Lm
2200 K

A+



LED Kühlschranklicht klar

LED Fridge Lamp clear

50263
70 / 280



E14
CRI 90

1,5W
11W

100 Lm
2200 K

A+



LED Kühlschranklicht klar

LED Fridge Lamp clear

50638
70 / 280



E14
CRI 90

1,5W
13W

120 Lm
2600 K

A+



LED French Candle NEW

LED French Candle

50230
24 / 96



E14
CRI 90

1,5W
9W

90 Lm
2200 K

A+



LED French Candle klar

LED French Candle clear

50231
24 / 96



E10
CRI 90

1,5W
9W

90 Lm
2600 K

A+



LED Dutch Candle klar

LED Dutch Candle clear

50232
24 / 96



E14
CRI 90

2,2W
20W

200 Lm
2600 K

A+





© CULTURE CLUB

LED Tube klar
LED Tube clear

50264
24 / 96



E14
CRI 90

2,7W
20W

200 Lm
2200 K

A+



LED Tube klar
LED Tube clear

50679
24 / 96



E14
CRI 90

2,7W
25W

250 Lm
2600 K

A+



LED Long Tube 185
LED Long Tube 185

50395
8 / 32



E27
CRI 90

6,0W
40W

470 Lm
2200 K

A+



LED Long Tube 300
LED Long Tube 300

50396
21



E27
CRI 90

6,0W
40W

470 Lm
2200 K

A+





LED Linienlampe soft klar S14d 300mm

LED Linear Lamp soft clear

50181
 21



S14d
CRI 90

8,0W
 26W

270 Lm
 2200 K



LED Linienlampe soft klar S14s 300mm

LED Linear Lamp soft clear

50189
 21



S14s
CRI 90

8,0W
 26W

270 Lm
 2200 K

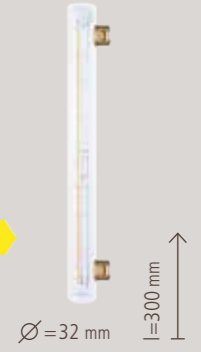

LED Linienlampe soft klar S14d 500mm

LED Linear Lamp soft clear

50185
 12



S14d
CRI 90

12,0W
 42W

500 Lm
 2200 K



LED Linienlampe soft klar S14s 500mm

LED Linear Lamp soft clear

50193
 12



S14s
CRI 90

12,0W
 42W

500 Lm
 2200 K





LED G9 Leuchtmittel

LED G9 Pin

50607
 70 / 280



G9
CRI 90

1,5W
 10W

100 Lm
 2200 K

A+



Ø = 14 mm

l = 57 mm

LED G9 Leuchtmittel

LED G9 Pin

50608
 70 / 280



G9
CRI 90

2,7W
 20W

200 Lm
 2200 K

A+



Ø = 14 mm

l = 68 mm

LED G9 Leuchtmittel

LED G9 Pin

50609
 70 / 280



G9
CRI 90

1,5W
 12W

120 Lm
 2600 K

A+



Ø = 14 mm

l = 57 mm

LED G9 Leuchtmittel

LED G9 Pin

50610
 70 / 280



G9
CRI 90

2,7W
 25W

250 Lm
 2600 K

A+



Ø = 14 mm

l = 68 mm

AMBIENT DIMMING

Die brandneuen Lampen mit „Ambient Dimming“-Technologie kommen dem Vorbild Glühlampe in der Lichtfarbe so nahe wie nie zuvor.

Durch eine einzigartige Technologie verändern diese LED-Lampen während des Dimmvorgangs ihre Lichtfarbe – und strahlen bei abnehmender Lichtstärke kontinuierlich wärmer und rötlicher – ganz wie der Wendel einer traditionellen Glühlampe.

Die „Ambient Dimming“-Serie mit einer Vielzahl von Formen und Ausführungen zeigt unsere ganze Erfahrung und Kompetenz bei der Fertigung von dimmbaren LED-Filament-Lampen. Spiegelkopf- und Reflektorlampen sowie Spots runden das Programm ab. Gestalten Sie ein perfekt passendes Licht-Ambiente für jede gewünschte Stimmung - vom Einbruch der Dämmerung bis tief in die Nacht.

AMBIENT DIMMING

The brand new lamps with „Ambient Dimming“ technology come as close as ever to the traditional incandescent bulb regarding colour temperature.

Using a unique technology these LED lamps change the colour temperature while being dimmed. The decreasing light intensity continuously appears warmer – and more reddish – just like the filament of a traditional light bulb.

The „Ambient Dimming“ series with a variety of shapes and designs showcase our full experience and expertise in manufacturing dimmable LED filament lamps. Mirror-head-, reflector-lamps and spots complete the range. All of them create a perfectly matching lighting atmosphere for any desired mood; from the beginning of twilight until deep in the night.

LED AMBIENT LINE

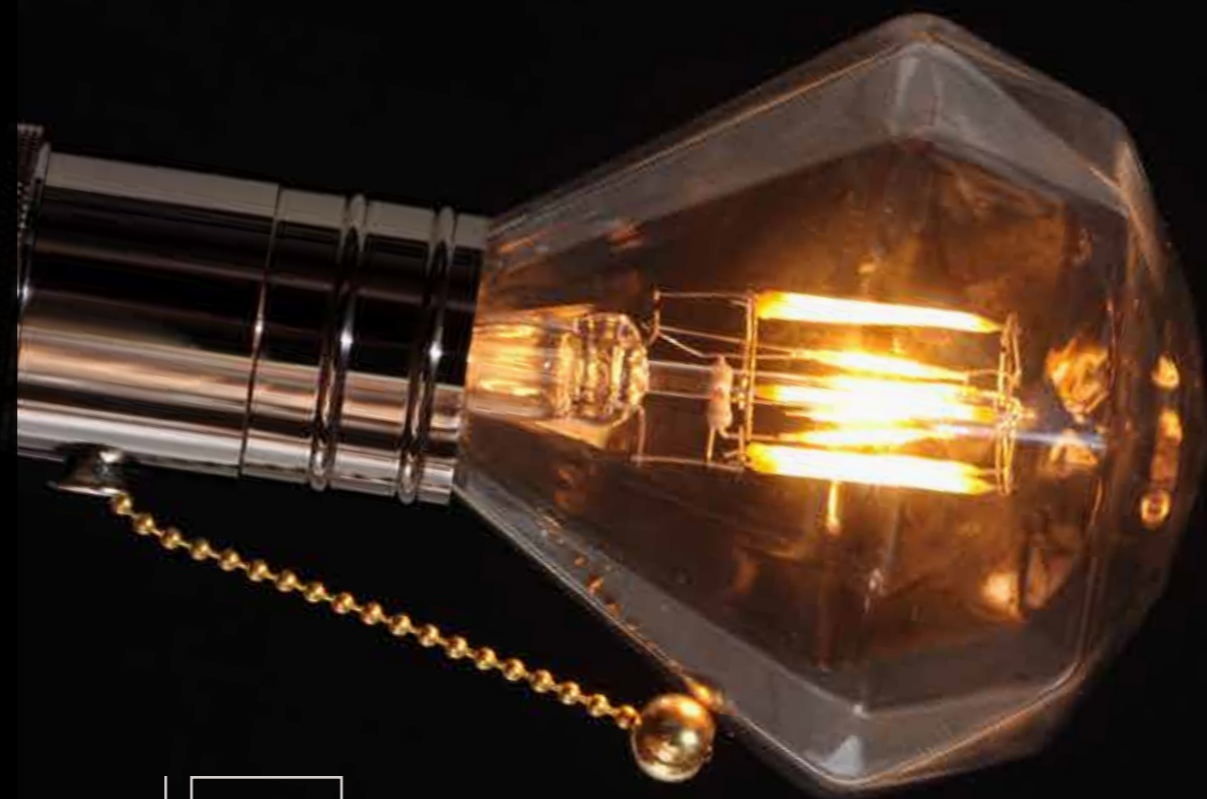

CRI
90

+35C
to
-20C

Hg
NO
MERCURY

SAVE UP TO
90%
ENERGY

ON / OFF
100.000

LIFETIME
20.000h



FARBTEMPERATUR
COLOUR TEMPERATURE
1.700 / 2.000 - 2.800 / 3.000 KELVIN

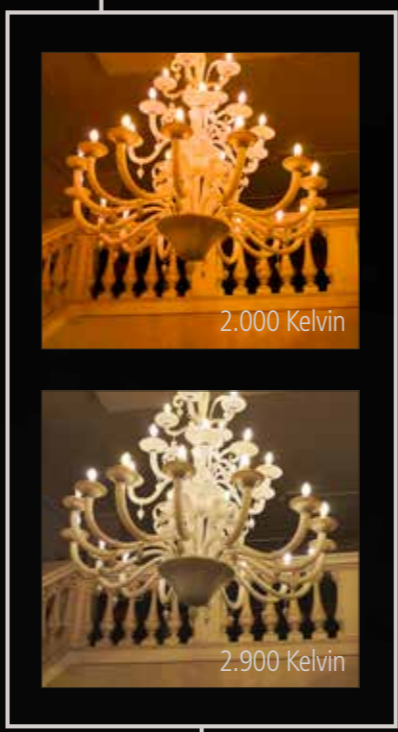



© EVENTMEISTER - SEASON & CO

EVENTMEISTER

AMBIENT DIMMING

2.000 - 2.900 KELVIN

LED Globe 95 klar

LED Globe 95 clear

50266
12



E27 3,5W
CRI 90 20W

200 Lm
2000-2900 K

A



Ø=95 mm
l=140 mm

LED Globe 95 opal

LED Globe 95 opal

50267
12



E27 3,5W
CRI 90 15W

150 Lm
2000-2900 K

A



Ø=95 mm
l=140 mm

LED Globe 125 klar

LED Globe 125 clear

50268
8



E27 8,0W
CRI 90 48W

600 Lm
2000-2900 K

A



Ø=125 mm
l=180 mm

LED Globe 125 opal

LED Globe 125 opal

50269
8



E27 8,0W
CRI 90 32W

350 Lm
2000-2900 K

B



Ø=125 mm
l=180 mm

LED Diamant klar

LED Diamond clear

50706
12



E27 8,0W
CRI 90 42W

500 Lm
2000-2900 K

A



Ø=110 mm
l=140 mm

AMBIENT LINE

GLOBE
Globe 95, 125 Diamant Diamond



AMBIENT DIMMING

2.000 - 2.900 KELVIN

LED Glühlampe klar

LED Bulb clear

50244
12 / 48



E27
CRI 90

2,7W
12W

120 Lm
2000-2900 K

A



LED Glühlampe matt

LED Bulb frosted

50245
12 / 48



E27
CRI 90

2,7W
12W

120 Lm
2000-2900 K

A



LED Glühlampe klar

LED Bulb clear

50248
8 / 32



E27
CRI 90

8,0W
48W

600 Lm
2000-2900 K

A



LED Glühlampe matt

LED Bulb frosted

50249
8 / 32



E27
CRI 90

8,0W
39W

450 Lm
2000-2900 K

A



LED Glühlampe opal

LED Bulb opal

50247
8 / 32



E27
CRI 90

8,0W
37W

420 Lm
2000-2900 K

A





AMBIENT DIMMING

2.000 - 2.900 KELVIN

LED Kerze klar

LED Candle clear

50241
24 / 96



E14 4,0W
CRI 90 26W

260 Lm
2000-2900 K



LED Kerze matt

LED Candle frosted

50240
24 / 96



E14 4,0W
CRI 90 25W

250 Lm
2000-2900 K



LED Kerze Windstoß klar

LED Candle Flame clear

50237
24 / 96



E14 3,5W
CRI 90 22W

220 Lm
2000-2900 K



LED Kerze Windstoß matt

LED Candle Flame frosted

50238
24 / 96



E14 3,5W
CRI 90 20W

200 Lm
2000-2900 K

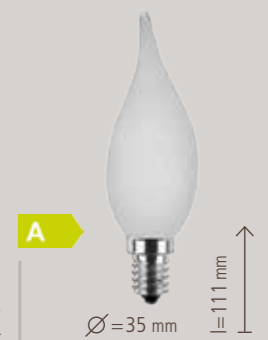



AMBIENT DIMMING

2.000 - 2.900 KELVIN

LED Tropfenlampe klar

LED Drop Lamp clear

50242
12 / 48



E14 2,7W
CRI 90 12W

120 Lm
2000-2900 K

A



LED Tropfenlampe matt

LED Drop Lamp frosted

50243
12 / 48



E14 2,7W
CRI 90 12W

120 Lm
2000-2900 K

A



LED Glühlampe Spiegelkopf

LED Bulb Mirror Head

ABSTRAHLWINKEL
BEAM ANGLE

180°

50279
12 / 48



E14 2,7W
CRI 90 9W

90 Lm
2000-2900 K

A



LED Glühlampe Spiegelkopf

LED Bulb Mirror Head

ABSTRAHLWINKEL
BEAM ANGLE

180°

50280
8 / 32



E27 4,0W
CRI 90 21W

200 Lm
2000-2900 K

A



LED Globe 125 Spiegelkopf

LED Globe 125 Mirror Head

ABSTRAHLWINKEL
BEAM ANGLE

180°

50281
8



E27 8,0W
CRI 90 37W

430 Lm
2000-2900 K

A





AMBIENT DIMMING

2.000 - 2.900 KELVIN

LED Glühlampe Spiegelkopf gold

LED Bulb Mirror Head golden

ABSTRAHLWINKEL
BEAM ANGLE

180°



50496

8 / 32



E27

CRI 90

4,0W

21W

200 Lm

2000-2900 K

A

∅ = 60 mm

l = 106 mm

LED Glühlampe Spiegelkopf kupfer

LED Bulb Mirror Head copper

ABSTRAHLWINKEL
BEAM ANGLE

180°



50497

8 / 32



E27

CRI 90

4,0W

21W

200 Lm

2000-2900 K

A

∅ = 60 mm

l = 106 mm

LED Globe 125 Spiegelkopf gold

LED Globe Mirror Head golden

ABSTRAHLWINKEL
BEAM ANGLE

180°

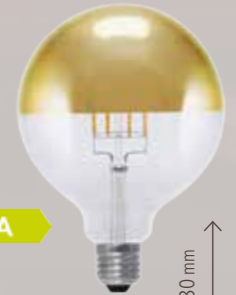

50494

8



E27

CRI 90

8,0W

35W

400 Lm

2000-2900 K

A

∅ = 125 mm

l = 180 mm

LED Globe 125 Spiegelkopf kupfer

LED Globe Mirror Head copper

ABSTRAHLWINKEL
BEAM ANGLE

180°



50495

8



E27

CRI 90

8,0W

35W

400 Lm

2000-2900 K

A

∅ = 125 mm

l = 180 mm



AMBIENT DIMMING

2.000 - 2.900 KELVIN

AMBIENT LINE

LED Reflektor R50

LED Reflector R50

ABSTRAHLWINKEL
BEAM ANGLE

45°

50725

12 / 48



E14

CRI 90

2,7W

10W

100 Lm

2000-2900 K

A



∅=50 mm

l=87 mm

LED Reflektor R63

LED Reflector R63

ABSTRAHLWINKEL
BEAM ANGLE

45°

50726

8 / 32



E27

CRI 90

3,0W

25W

140 Lm

2000-2900 K

A



∅=63 mm

l=105 mm

LED Reflektor R80

LED Reflector R80

ABSTRAHLWINKEL
BEAM ANGLE

70°

50727

20



E27

CRI 90

8,0W

50W

400 Lm

2000-2900 K

A



∅=80 mm

l=115 mm

REFLEKTOR REFLECTOR
R50 R63 R80



AMBIENT DIMMING

2.000 - 3.000 KELVIN

1.700 K / 2.000 K **AMBIENT DIMMING** 2.800 K / 3.000 K



ABSTRAHLWINKEL
BEAM ANGLE

40°

LED Ambient Dimming Reflektor GU10

LED Ambient Dimming Reflector GU10

50220

10 / 40



GU10

CRI 90

7,0W

35W

350 Lm

1700-2800 K

A



∅=50 mm

l=58 mm

ABSTRAHLWINKEL
BEAM ANGLE

40°

LED Ambient Dimming Reflektor MR16

LED Ambient Dimming Reflector MR16

50222

10 / 40



MR16

CRI 80

7,0W

40W

410 Lm

2000-3000 K

A



∅=50 mm

l=48 mm

ABSTRAHLWINKEL
BEAM ANGLE

36°

LED Ambient Dimming Reflektor AR111 **NEW**

LED Ambient Dimming Reflector AR111

50719

30



G53

CRI 90

15W

75W

650 Lm

2000-3000 K

A



∅=111 mm

l=70 mm



CLASSIC SERIE

Beste Energie-Effizienz bei extra hoher Lichtleistung bis 1.900 Lumen, natürlich schöne, warme Lichtfarben, kompakte Bauformen mit eleganter Optik, vielfältige Sockel von G4 über G9, G53, GU10 und R7s bis hin zu E10, E14 und E27: Dafür steht unsere preislich besonders attraktive Classic-Serie!

Wählen Sie unter mattiertem, opalem, goldgetöntem, verspiegeltem oder farbigem Glas für blendfreie 360°-Rundum-Abstrahlung. Mit klaren Lampen setzen Sie funkelnde Akzente, leistungsfähige Spots sorgen für eine gezielte Ausleuchtung.

Mit unserer Classic-Serie ersetzen Sie praktisch jede gängige Halogen- und Glühlampe von 20 – 120 Watt. Neu: Viele Bauformen sind jetzt auch in dimmbarer Ausführung erhältlich!

CLASSIC LINE

Best Energy Efficiency combined with extra-high light output up to 1,900 lumens. Naturally beautiful warm light colours, compact designs with elegant appearance, a variety of base from G4 to G9, g53, GU10 and R7s, up to E10, E14 and E27: That is what our value-priced Classic-Line stands for!

Chose between matt, opal, golden tone, mirrored or coloured glass - all for soft, glare-free 360° light distribution. Set sparkling light effects with clear glass lamps - and create directed illumination with our powerful spotlights.

Our "Classic" Line offers a direct replacement for virtually each popular incandescent or halogen bulb from 20 to 120 watts.

CRI
80

+35C
to
-20C

Hg
NO
MERCURY

SAVE UP TO
90%
ENERGY

ON / OFF
100.000

LIFETIME
15.000h





LED Kerze Twist gold

LED Candle Twist golden

GOLD GOLDEN



60371
 10 / 100



E14 **4,0W** **350 Lm**
CRI 80 32W 2400K

LED Rustika gold

LED Rustica golden

GOLD GOLDEN



60483
 24



E27 **4,0W** **400 Lm**
CRI 80 37W 2400K

LED Globe 95 gold

LED Globe 95 golden

GOLD GOLDEN

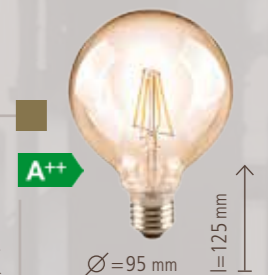

60484
 20





E27 **6,0W** **700 Lm**
CRI 80 54W 2400K

LED Globe 125 gold

LED Globe 125 golden

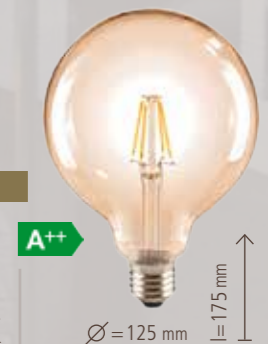
GOLD GOLDEN



60485
 20



E27 **6,0W** **700 Lm**
CRI 80 54W 2400K



LED Globe 95 klar
LED Globe 95 clear

60382
20



E27
CRI 80

8,0W
75W

1055 Lm
2700K

A++



LED Globe 125 klar
LED Globe 125 clear

60383
20



E27
CRI 80

8,0W
75W

1050 Lm
2700K

A++



LED Globe 125 opal
LED Globe 125 opal

60387
20



E27
CRI 80

10,0W
75W

1080 Lm
2700K

A+



**HIGH
BRIGHTNESS**



© PHANTASIALAND

LED Tube Plus klar NEW
LED Tube Plus clear

50590
8



E27
CRI 90

12 W
60 W

850 Lm
2800 K

Filament PLUS +

A



Ø = 32 mm
l = 170 mm

LED Tube Plus klar NEW
LED Tube Plus clear

50591
8



E27
CRI 90

12 W
60 W

850 Lm
2800 K

Filament PLUS +

A



Ø = 45 mm
l = 145 mm

LED Tube Plus klar NEW
LED Tube Plus clear

50598
8



E27
CRI 90

15 W
70 W

1000 Lm
2800 K

Filament PLUS +

A



Ø = 45 mm
l = 170 mm

LED Globe 125 Plus klar NEW
LED Globe 125 Plus clear

50593
8



E27
CRI 90

15 W
70 W

1000 Lm
2200 K

Filament PLUS +

A



Ø = 125 mm
l = 185 mm

HIGH BRIGHTNESS

© PHANTASIALAND

LED Tube High Brightness klar **NEW**

LED Tube High Brightness clear

High Brightness

Filament PLUS

A



l=230 mm
Ø=48 mm

50891

8



E27
CRI 90

20W 1600 Lm
120W 2700K

LED Tube High Brightness matt **NEW**

LED Tube High Brightness frosted

High Brightness

Filament PLUS

A



l=230 mm
Ø=48 mm

50892

8



E27
CRI 90

20W 1550 Lm
115W 2700K

LED Tube High Brightness Daylight klar

LED Tube High Brightness Daylight clear **NEW**

Daylight 5.600 K

High Brightness

Filament PLUS

A+



l=230 mm
Ø=48 mm

50893

8



E27
CRI 90

20W 1900 Lm
120W 5300K

LED Ellipse High Brightness klar **NEW**

LED Ellipse High Brightness clear

High Brightness

Filament PLUS

A+



l=225 mm
Ø=90 mm

50895

8



E27
CRI 90

20W 1850 Lm
120W 2700K

LED Ellipse High Brightness matt **NEW**

LED Ellipse High Brightness frosted

High Brightness

Filament PLUS

A+



l=225 mm
Ø=90 mm

50896

8



E27
CRI 90

20W 1800 Lm
115W 2700K

CLASSIC LINE

HIGH BRIGHTNESS
Ellipse Tube



LED Golfball klar

LED Golfball clear

60378
10 / 100



E27
CRI 80

1,5W
16W

150 Lm
2700K

A++



Ø=45 mm
l=72 mm

LED Glühlampe klar

LED Bulb clear

60379
10 / 100



E27
CRI 80

4,0W
40W

470 Lm
2700K

A++



Ø=60 mm
l=105 mm

LED Glühlampe matt

LED Bulb frosted

60479
10 / 100



E27
CRI 80

4,0W
40W

470 Lm
2700K

A++



Ø=60 mm
l=105 mm

LED Glühlampe klar

LED Bulb clear

60380
10 / 100



E27
CRI 80

7,0W
66W

910 Lm
2700K

A++



Ø=60 mm
l=105 mm

LED Glühlampe matt

LED Bulb frosted

60480
10 / 100



E27
CRI 80

7,0W
60W

806 Lm
2700K

A+



Ø=60 mm
l=105 mm

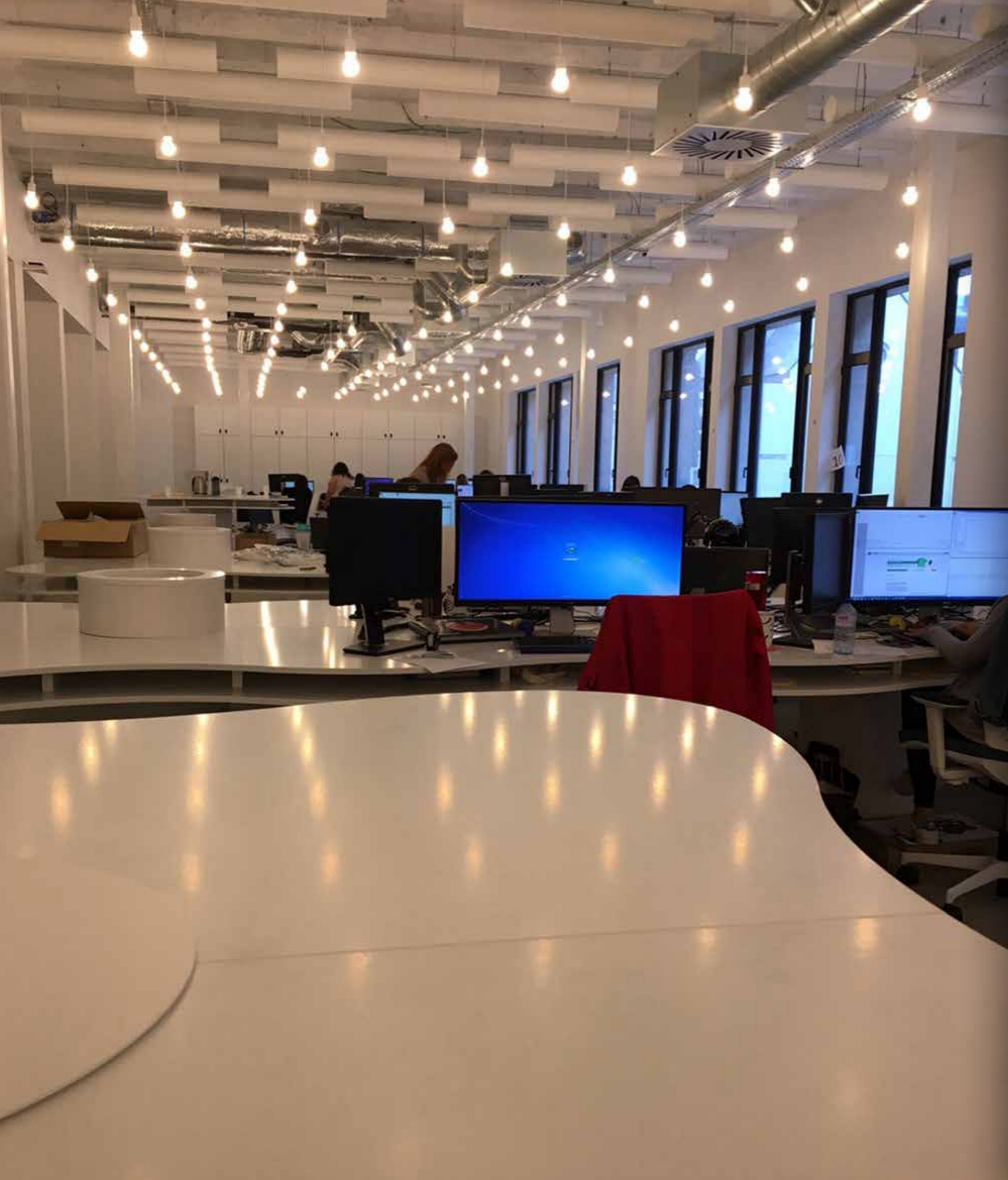

LED Glühlampe klar

LED Bulb clear

60381

10 / 100



E27
CRI 80

8,0W
75W

1055 Lm
2700K

A++



LED Glühlampe matt

LED Bulb frosted

60481

10 / 100



E27
CRI 80

8,0W
75W

1055 Lm
2700K

A++



LED Glühlampe A65 klar

LED Bulb A65 clear

60393

10 / 100



E27
CRI 80

12,0W
100W

1520 Lm
2700K

A++



LED Glühlampe A65 matt

LED Bulb A65 frosted

60394

10 / 100



E27
CRI 80

12,0W
100W

1520 Lm
2700K

A++





LED Kerze klar
LED Candle clear

60375
10 / 100



E14
CRI 80

2,0W
25W

250 Lm
2700 K

A++



Ø=35 mm



LED Kerze matt
LED Candle frosted

60474
10 / 100



E14
CRI 80

2,0W
25W

250 Lm
2700 K

A++



Ø=35 mm



LED Kerze klar
LED Kerze clear

60373
10 / 100



E14
CRI 80

4,0W
40W

470 Lm
2700 K

A++



Ø=35 mm



LED Kerze matt
LED Candle frosted

60473
10 / 100



E14
CRI 80

4,0W
40W

470 Lm
2700 K

A++



Ø=35 mm



LED Kerze Windstoß klar
LED Candle Flame clear

60376
10 / 100



E14
CRI 80

2,0W
25W

250 Lm
2700 K

A++



Ø=35 mm



LED Kerze Windstoß klar
LED Candle Flame clear

60374
10 / 100



E14
CRI 80

4,0W
40W

470 Lm
2700 K

A++



Ø=35 mm





LED Kerze Twist klar

LED Candle Twist clear

60372
 10 / 100



E14
CRI 80

4,0W
 40W

470 Lm
 2700K

A++



LED Tropfenlampe klar

LED Drop Lamp clear

60377
 10 / 100



E14
CRI 80

2,0W
 25W

250 Lm
 2700K

A++



LED Glühlampe Spiegelkopf

LED Bulb Mirror Head

ABSTRAHLWINKEL
BEAM ANGLE 180°

60389
 10 / 100



E14
CRI 80

4,5W
 35W

400 Lm
 2700K

A+



LED Glühlampe Spiegelkopf

LED Bulb Mirror Head

ABSTRAHLWINKEL
BEAM ANGLE 180°

60388
 10 / 100



E27
CRI 80

6,0W
 53W

700 Lm
 2700K

A+

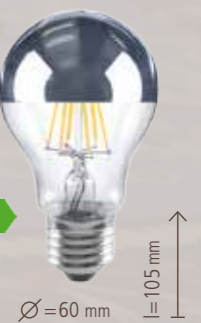



LED Reflektor AR111 G53
LED Reflector AR111 G53 **NEW**

ABSTRAHLWINKEL
BEAM ANGLE 36°



50716
30



G53 12W 550 Lm
CRI 90 75W 2700K



LED Reflektor AR111 G53
LED Reflector AR111 G53 **NEW**

ABSTRAHLWINKEL
BEAM ANGLE 36°



50717
30



G53 15W 700 Lm
CRI 90 95W 2700K

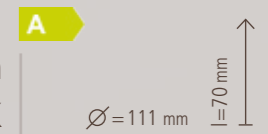



LED Reflektor PAR38 weiss

LED Reflector PAR38 white **NEW**

ABSTRAHLWINKEL
BEAM ANGLE

40°



50760

12



E27
CRI 80

18 W
200 W

1500 Lm
2700 K

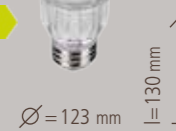

LED Reflektor PAR38 gelb

LED Reflector PAR38 yellow **NEW**

ABSTRAHLWINKEL
BEAM ANGLE

40°



50761

12



E27

18 W

Gelb
Yellow

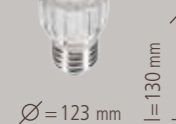

LED Reflektor PAR38 blau

LED Reflector PAR38 blue **NEW**

ABSTRAHLWINKEL
BEAM ANGLE

40°



50762

12



E27

18 W

Blau
Blue



LED Reflektor PAR38 grün

LED Reflector PAR38 green **NEW**

ABSTRAHLWINKEL
BEAM ANGLE

40°



50763

12



E27

18 W

Grün
Green

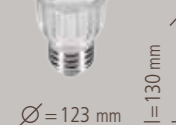

LED Reflektor PAR38 rot

LED Reflector PAR38 red **NEW**

ABSTRAHLWINKEL
BEAM ANGLE

40°



50764

12



E27

18 W

Rot
Red

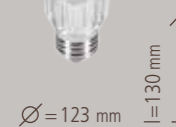



LED Reflektor MR11

LED Reflector MR11

ABSTRAHLWINKEL
BEAM ANGLE 36°

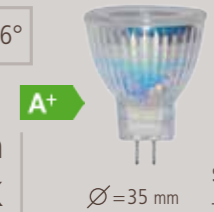

50616

10



MR11

CRI 80

3,0W

38W

250 Lm

3000K

A+

Ø=35 mm

l=42 mm

LED Reflektor MR16

LED Reflector MR16

ABSTRAHLWINKEL
BEAM ANGLE 36°



50625

10 / 40



MR16

CRI 80

4,5W

35W

400 Lm

2700K

A+

Ø=50 mm

l=45 mm

LED Reflektor GU10

LED Reflector GU10

ABSTRAHLWINKEL
BEAM ANGLE 30°

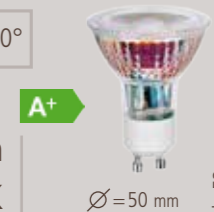

50621

10 / 40



GU10

CRI 80

5,0W

35W

400 Lm

2700K

A+

Ø=50 mm

l=53 mm

LED Reflektor MR16

LED Reflector MR16

ABSTRAHLWINKEL
BEAM ANGLE 40°

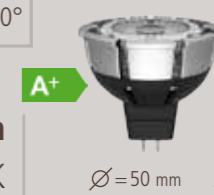

50223

10 / 40



MR16

CRI 90

7,0W

45W

510 Lm

3000K

A+

Ø=50 mm

l=48 mm

LED Reflektor GU10

LED Reflector GU10

ABSTRAHLWINKEL
BEAM ANGLE 40°

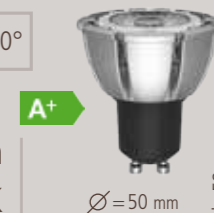

50221

10 / 40



GU10

CRI 80

7,0W

50W

480 Lm

3000K

A+

Ø=50 mm

l=58 mm



© PHANTASIALAND

LED G9 Leuchtmittel Glas NEW

LED G9 Pin Glass

60641
 10 / 100



G9
CRI 80

2W
 25W

250 Lm
 2700K

A++



Ø = 13 mm
 l = 47 mm

LED G9 Leuchtmittel 3er Pack

LED G9 Pin 3pcs Set

60636
 60 / 300



G9
CRI 80

2,5W
 20W

180 Lm
 2700K

A+



Ø = 16 mm
 l = 47 mm

LED Stablampe R7s

LED Tubular Lamp R7s

DIMMBAR DIMMABLE

50710
 8 / 32



R7
CRI 90

8,0W
 54W

700 Lm
 2600K

A+

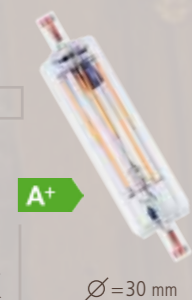

Ø = 30 mm
 l = 118 mm

LED Stablampe R7s

LED Tubular Lamp R7s

ABSTRAHLWINKEL
BEAM ANGLE

120°

50715
 10 / 100



R7
CRI 80

9,5W
 60W

810 Lm
 2700K

A+



Ø = 16 mm
 l = 118 mm



LED G4 Leuchtmittel klar

LED G4 Pin clear

50617

70 / 280



G4
CRI 90

2,0W
17W

160 Lm
2600K

A+



Ø = 16 mm

l = 45 mm

LED G4 Leuchtmittel matt

LED G4 Pin frosted

50618

70 / 280



G4
CRI 90

2,0W
17W

150 Lm
2600K

A+



Ø = 16 mm

l = 45 mm

LED G6.35 Leuchtmittel 3er Pack **NEW**

LED G6.35 Pin 3pcs Set

60633

60 / 300



G6.35
CRI 80

1,5W
10W

110 Lm
2700K

A+



Ø = 12 mm

l = 37 mm

LED G4 Leuchtmittel 3er Pack

LED G4 Pin 3pcs Set

60635

60 / 300



G4
CRI 80

1,5W
10W

100 Lm
2700K

A+



Ø = 12 mm

l = 37 mm

XTRA SERIE

Schaffen Sie mit der klassischen Optik frei hängender SEGULA Filament-Lampen eine unvergleichliche Licht-Atmosphäre: Passend zu unserem hochwertigen Leuchtmittel-Sortiment finden Sie bei SEGULA professionelle LED-Dimmer, eine breite Auswahl an Lampenfassungen in traditioneller und moderner Optik und in vielen Materialien, Farben und Versionen. Dazu bieten wir ein exklusives Sortiment an Textilkabeln in 2- und 3adriger Ausführung – Sie haben die Wahl aus über 40 verschiedenen Farben.

Gern erstellen wir Ihnen ein individuelles Angebot ihrer Wunschkombination – genau passend für Ihr Projekt.

XTRA LINE

Create an unparalleled light atmosphere with the classical look of freely suspended SEGULA filament lamps: Especially adapted for our range of high-quality lamps at SEGULA you'll find professional LED dimmers and a wide selection of lamp sockets in traditional and modern appearance made from many materials, with different colours and designs. We also provide an exclusive range of textile cables in 2- and 3-wire version - make your choice from more than 40 different colours.

We are happy to create an individual quotation for your desired combination – just fitting for your projects.



DIMMER

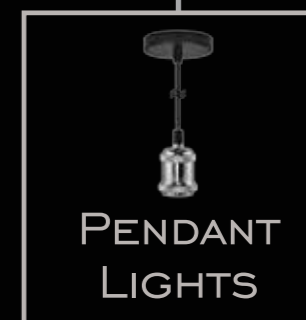

PENDANT LIGHTS



NEUHEITEN

PROFESSIONELLE LED-DIMMER

Dimmen Sie SEGULA LED-Leuchtmittel bequem mit diesen formschönen Leitungsdimmern (Kabeldimmer). Die SEGULA LED-Dimmer sind in der Mindestlast auf unsere extrem energieeffizienten Lampen abgestimmt und bieten stufenloses Dimmen von 0-100% der Lichtleistung. Hinter der ästhetischen und klaren Formen verbirgt sich eine hochwertige, transistorgesteuerte und somit lautlose Elektronik. Die formschöne Optik harmoniert perfekt auch mit unseren Textilkabeln. Alle Dimmer werden in Deutschland entwickelt und hergestellt.

PROFESSIONAL LED-DIMMERS

Dim SEGULA LED lamps comfortably with these shapely line dimmers (cable dimmer). The SEGULA LED dimmers are matched to the minimum load of our extremely energy-efficient lamps and offer stepless dimming from 0-100% light output. Inside the aesthetically and clean designed housing conceals a high-quality, transistor controlled and therefore noiseless electronics. The attractive appearance harmonizes perfectly with our textile cables. All dimmers are designed and manufactured in Germany.

Made in GERMANY



LED Schnurdimmer FUSS-TASTER
LED Cable Dimmer FOOT SWITCHER

50845 Schwarz Black

10 IP20 220-240V~ 50/60Hz LED 3-55W



LED Dimmen LED dimming
Standby ohne Verbrauch No standby consumption
Dimmt LED-, Glüh- und Halogenlampen Dims LED, incandescent and halogen lamps
Zum Einbau in die Netzzuleitung For installation in the mains supply line
Universell in Innenräumen einsetzbar Universal indoor use
230V Phasenanschnitt-Verfahren 230V phase control method
Leitungsquerschnitte bis 1,5 mm² Wire diameters up to 1.5 mm²

LED Schnurdimmer DREHREGLER
LED Cable Dimmer ROTARY CONTROL

50840 Schwarz Black

50841 Weiss White

50843 Transparent Transparent

10 IP20 220-240V~ 50/60Hz LED 3-35W



LED Schnurdimmer DRUCKTASTE
LED Cable Dimmer PUSH BUTTON

50846 Schwarz Black

50847 Weiss White

50848 Transparent Transparent

10 IP20 220-240V~ 50/60Hz LED 3-35W





Pendelleuchte CHICAGO MESSING
Pendant Light CHICAGO BRASS

50561 E27 220-240V~ 50/60Hz
5 / 25 3x0,75 mm²/max. 25W

Textilkabel
Textile cable

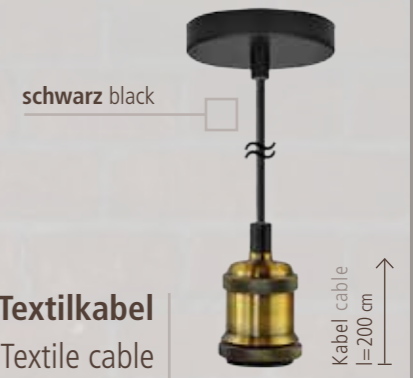

Pendelleuchte CHICAGO SILBER
Pendant Light CHICAGO SILVER

50562 E27 220-240V~ 50/60Hz
5 / 25 3x0,75 mm²/max. 25W

Textilkabel
Textile cable



Pendelleuchte CHICAGO SCHWARZ
Pendant Light CHICAGO BLACK

50563 E27 220-240V~ 50/60Hz
5 / 25 3x0,75 mm²/max. 25W

Textilkabel
Textile cable



Pendelleuchte CHICAGO KUPFER
Pendant Light CHICAGO COPPER

50564 E27 220-240V~ 50/60Hz
5 / 25 3x0,75 mm²/max. 25W

Textilkabel
Textile cable

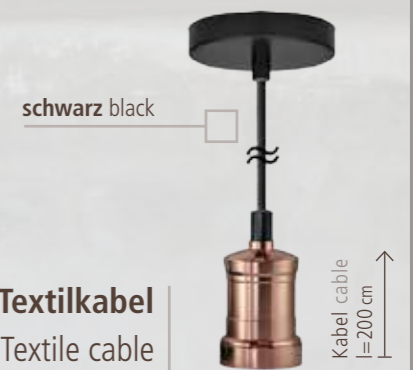

Pendelleuchte CHICAGO MESSING/BRAUN
Pendant Light CHICAGO BRASS/BROWN

50567 E27 220-240V~ 50/60Hz
5 / 25 3x0,75 mm²/max. 25W

Textilkabel
Textile cable





Pendelleuchte VEGAS GOLD

Pendant Light VEGAS GOLDEN

50565	E27	220-240V~ 50/60Hz	Textilkabel
5 / 25		3x0,75 mm ² /max. 25W	Textile cable



Pendelleuchte MIAMI ROSE-KUPFER

Pendant Light MIAMI ROSE COPPER

50568	E27	220-240V~ 50/60Hz	Textilkabel
5 / 25		3x0,75 mm ² /max. 25W	Textile cable



Pendelleuchte MIAMI ROSE-NICKEL

Pendant Light MIAMI ROSE NICKEL

50569	E27	220-240V~ 50/60Hz	Textilkabel
5 / 25		3x0,75 mm ² /max. 25W	Textile cable



Pendelleuchte DALLAS BETON

Pendant Light DALLAS CONCRETE

50566	E27	220-240V~ 50/60Hz	Textilkabel
8		2x0,75 mm ² /max. 25W	Textile cable





Pendelleuchte ATLANTA MESSING ZUGSCHALTER

Pendant Light ATLANTA BRASS PULL SWITCH

50516	E27	220-240V~ 50/60Hz	Textilkabel
5 / 25		3x0,75 mm ² /max. 25W	Textile cable



Pendelleuchte ATLANTA SCHWARZ ZUGSCHALTER

Pendant Light ATLANTA BLACK PULL SWITCH

50517	E27	220-240V~ 50/60Hz	Textilkabel
5 / 25		3x0,75 mm ² /max. 25W	Textile cable



Pendelleuchte ATLANTA MESSING DREHSCHALTER

Pendant Light ATLANTA BRASS ROTARY SWITCH

50518	E27	220-240V~ 50/60Hz	Textilkabel
5 / 25		3x0,75 mm ² /max. 25W	Textile cable

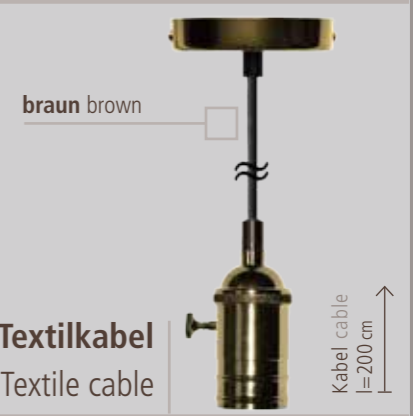

Pendelleuchte ATLANTA SCHWARZ DREHSCHALTER

Pendant Light ATLANTA BLACK ROTARY SWITCH

50519	E27	220-240V~ 50/60Hz	Textilkabel
5 / 25		3x0,75 mm ² /max. 25W	Textile cable

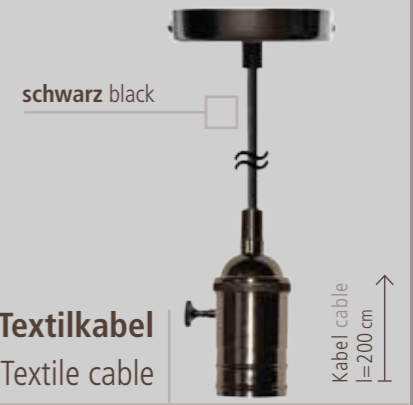



Pendelleuchte BOSTON ROT

Pendant Light BOSTON RED

50570 | **E27** | **220-240V~ 50/60Hz**
 5 / 25 | 2x0,75 mm²/max.25W

Silikonkabel
Silicone cable



Pendelleuchte BOSTON WEISS

Pendant Light BOSTON WHITE

50571 | **E27** | **220-240V~ 50/60Hz**
 5 / 25 | 2x0,75 mm²/max.25W

Silikonkabel
Silicone cable

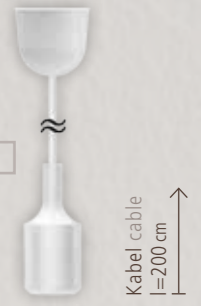

Pendelleuchte BOSTON SCHWARZ

Pendant Light BOSTON BLACK

50572 | **E27** | **220-240V~ 50/60Hz**
 5 / 25 | 2x0,75 mm²/max.25W

Silikonkabel
Silicone cable

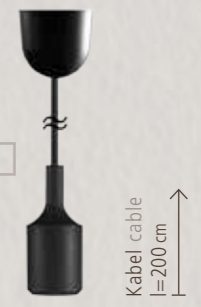

Pendelleuchte NEW YORK ROT

Pendant Light NEW YORK RED

50575 | **E27** | **220-240V~ 50/60Hz**
 5 / 25 | 2x0,75 mm²/max.25W

Textilkabel
Textile cable



Pendelleuchte NEW YORK WEISS

Pendant Light NEW YORK WHITE

50576 | **E27** | **220-240V~ 50/60Hz**
 5 / 25 | 2x0,75 mm²/max.25W

Textilkabel
Textile cable

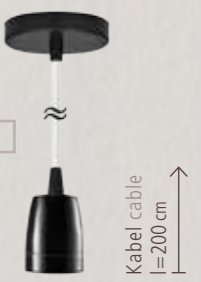

Pendelleuchte NEW YORK SCHWARZ

Pendant Light NEW YORK BLACK

50577 | **E27** | **220-240V~ 50/60Hz**
 5 / 25 | 2x0,75 mm²/max.25W

Textilkabel
Textile cable

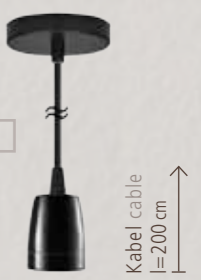

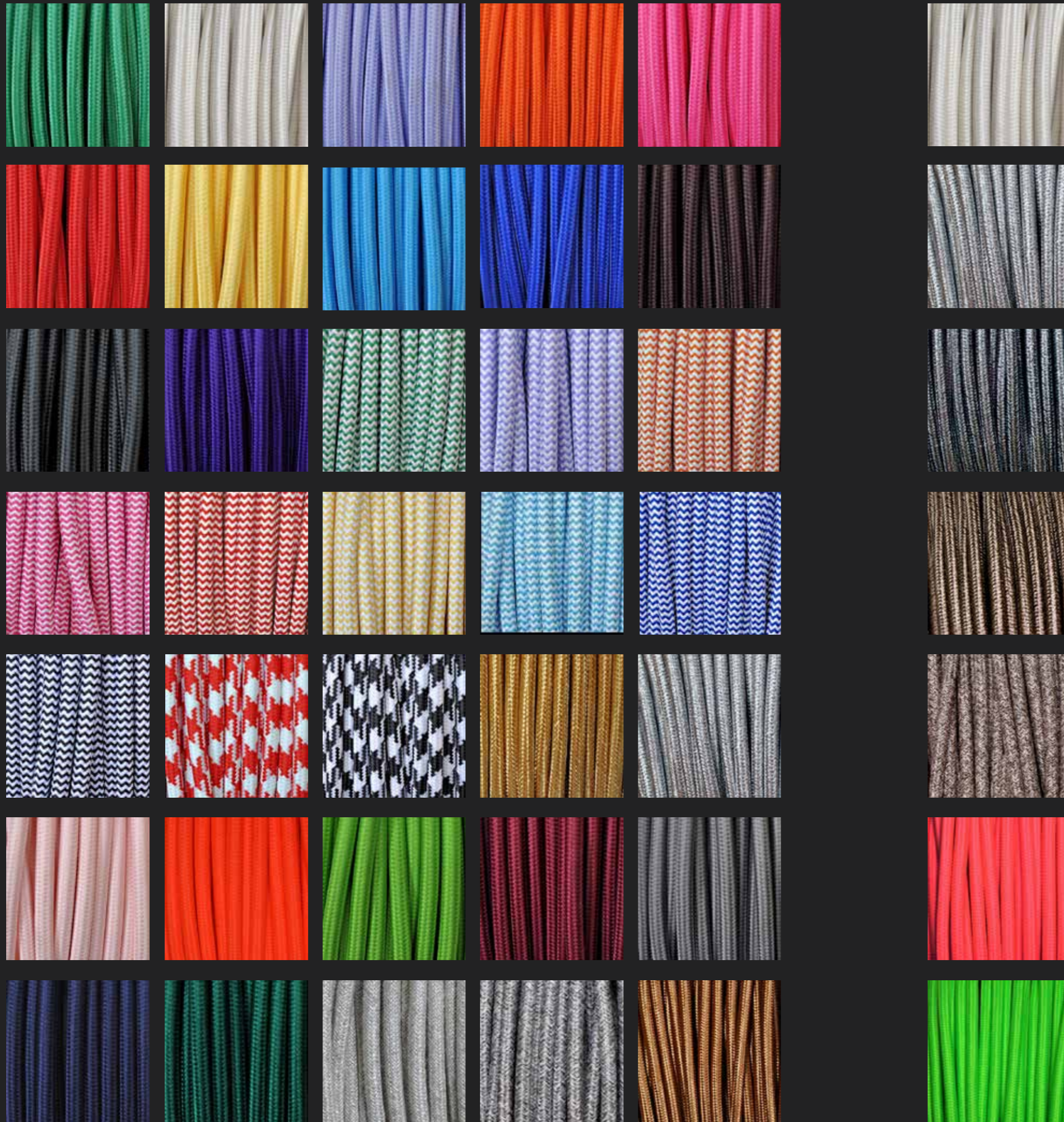

Textilkabel

Für individuelle Projekte liefern wir über 40 verschiedene Typen von textilmflochtenen Leitungen in Top-Qualität. Wählen Sie zwischen 2- und 3-adriger Ausführung in verschiedenen Oberflächen und Farbkombinationen. Alle unsere Kabel haben Leitungsquerschnitte von 0,75 mm², sind VDE-geprüft und zeichnen sich durch Baumwoll-Anteile in der Ummantelung und einen hohen Silikonanteil im Kunststoff aus.

Die Mindestabnahme beträgt 100 m, ab einer Menge von 500 m sind auch individuelle Sonderfarben nach der Pantone-Farbpalette möglich. Die Lieferzeit beträgt für alle Textilkabel 6-12 Wochen.

Textile Cable

For individual projects we supply more than 40 different types of textile braided cables in top quality. Choose between 2- and 3-wire version with different surfaces and colour combinations. All our cables have a wire cross-section of 0.75 mm², are VDE-tested and are distinguished by a share of natural cotton in the sheath and a high silicon content in the plastic isolation.

The minimum purchase for standard versions is 100 m, for individual colours according to the Pantone scheme a minimum quantity of 500 m is required. Delivery time for all textile cables will be 6-12 weeks.

Pendelleuchten
Pendant Lights

Textilkabel
Textile cable

VINTAGE LINE
DESIGN LINE
CLASSIC LINE

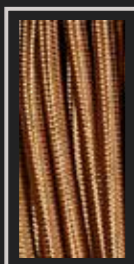
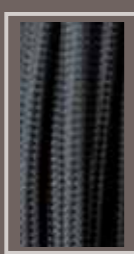
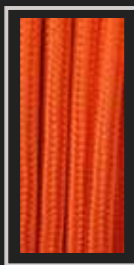

SETS

Pendelleuchte + Kabel + Lampe
Pendant light + Cable + Lamp

Pendel-Sets

Stellen Sie sich für Ihre Projekte ihr individuelles Set, bestehend aus Pendel-Leuchte, Textilkabel und SEGULA LED-Filament-Lampe zusammen. Egal ob Sie einen antiken oder modernen Look bevorzugen – der Vielfalt sind nahezu keine Grenzen gesetzt. Alle Sets sind sicherheitstechnisch geprüft, alle Teile sind VDE-zertifiziert – wir garantieren in jedem Detail erstklassige Qualität für professionelle Anwendung.

Die Mindestmenge für individuell gefertigte Sets beträgt 250 Stk., die Lieferzeit ca. 6-12 Wochen.

Pendant Sets

Arrange your individual pendant set consisting of pendant fixture, textile cable and SEGULA LED filament lamp. Whether you prefer an antique or modern look - the variety of designs is virtually unlimited. All sets are safety-tested, all parts VDE certified - we guarantee first class quality for professional use in every detail.

The minimum quantity for custom-made sets is 250 pcs., delivery time will be 6-12 weeks.

LED Glühlampe klar

LED Bulb clear

50248

8 / 32



E27

CRI 90

8,0W

48W

600 Lm

2000-2900K

A



Ø = 60 mm

h = 106 mm

Verpackungseinheit Delivery unit**Helligkeit dimmbar** Brightness dimmable**Getestete Dimmer** Tested dimmers: www.segula.lighting**Lichtfarbe dimmbar** Luminous colour dimmable

1.700 / 2.000 - 2800 / 3000 Kelvin

Abmessungen Dimensions

Durchmesser und Länge des Leuchtmittels in mm.

Diameter and length of the lamp in mm.

Lichtstrom (lm = Lumen) Luminous flux (lm = lumen)

Der Lichtstrom ist die Lichtleistung eines Leuchtmittels. Er beschreibt die gesamte abstrahlende Lichtmenge eines Leuchtmittels, unabhängig von der Abstrahlrichtung.

The luminous flux is the power radiated from a light source. It expresses the total light emitted by a light source, regardless of the beam direction.

Lichtfarbe (K = Kelvin) Luminous colour (K = kelvin)

Die Lichtfarbe beschreibt das farbliche Aussehen des Lichtes eines Leuchtmittels. Sie wird charakterisiert durch die Farbtemperatur gemessen in Kelvin. Dabei können bestimmte Lichtfarben unterschiedliche Farbwiedergabeeigenschaften haben und somit die Raumatmosphäre beeinflussen. Warmweißes Licht wird als gemütlich und behaglich empfunden. Neutralweißes Licht wird eher als sachlich wahrgenommen.

The luminous colour expresses the coloured appearance of the light from a light source. It is characterised by the colour temperature measured in kelvins. Certain light colours may have different colour rendering properties and hence have an effect on the atmosphere of a room. Soft white light is perceived as cosy and comfortable. Neutral white light tend to be perceived as practical.

Kerze Candle 1.900 K **Glühlampe** bulb lamp 2.700 - 2.900 K**Leuchtstofflampe** Fluorescent lamp 2.800 - 6.000 K**Mondlicht** Moonlight 4.100 K **Tageslicht** Daylight 5.000 - 6.000 K**Elektrische Leistung (W) und Wattäquivalent** Electric light power (W) and Watt equivalent

Die elektrische Leistung der LED Lampe wird in Watt angegeben. Das Wattäquivalent entspricht der Leistung einer dem Lichtstrom entsprechenden herkömmlichen Glühlampe.

The electric power of the LED lamp is specified in watts. The Watt equivalent corresponds to the power of a conventional incandescent lamp's luminous flux.

Farbwiedergabeindex (CRI) Colour rendering index (CRI)

Der Color Rendering Index (CRI) ist der Farbwiedergabeindex, der zur Charakterisierung von Lichtquellen dient. Er ist ein Index für die Natürlichkeit der Farbe. Je größer der Farbwiedergabeindex, desto natürlicher werden Farben wiedergegeben und desto angenehmer werden sie empfunden. Die Größe des Wertes kann zwischen 0 und 100 liegen und ist maßgeblich für die Farbwiedergabe von beleuchteten Gegenständen.

The colour rendering index (CRI) serves to characterise light sources. It is an index for the naturalness of colour. The higher the colour rendering index, the more natural is the rendering of colours and the more pleasant the perception of them. The value may be between 0 and 100 and is a measure of colour rendering of illuminated objects.



CLASSIC
LINE
DISPLAY

SERVICE

Unsere Handelspartner unterstützen wir gern mit individuellen Display-Lösungen für den Point of Sale. Wählen Sie die Bestückung Ihres Display aus unserem einzigartigen Angebot von über 150 verschiedenen Leuchtmitteln und Sets. Entdecken Sie auch unser Programm für die architektonische Beleuchtung und unser Technik-Sortiment – für den privaten Haushalt wie für die professionelle Anwendung in Gastronomie, Hotellerie und Gewerbe. Fragen Sie nach unseren Katalogen!

SERVICE

We support our business partners with individual point of sale display solutions. Choose the assortment of your display from our unique range of over 150 different bulbs and kits. Discover also our range for architectural lighting and design-sockets and switches – for the home as well as for professional use in the leisure, hotel, domestic, commercial and industrial sectors. Please contact us and request our catalogues.



VINTAGE
LINE
DISPLAY



SEGULA TEAM DEUTSCHLAND

Zu jedem guten Geschäft gehört ein guter Service. Unser Ziel ist es, unseren Kunden die besten Produkte mit dem besten Service zu bieten. Dafür arbeitet unser gesamtes Team Tag für Tag. Auch nach dem Kauf unserer Produkte sind wir weiterhin für Sie da. Kontaktieren Sie uns: telefonisch, per Fax oder per E-Mail.

SEGULA TEAM GERMANY

A good service is the basis for any good business. Our aim is to offer our customers superior products with superior service – this is what our complete team is working for day after day. After the purchase of our products we remain at your side. Contact us by phone, fax or E-mail.

OFFICE ZENTRALE DEUTSCHLAND HEADQUARTER GERMANY

SEGULA GmbH
Bergwiesenäcker 15
D-72160 Horb

info@segula.de
www.segula.lighting

Phone: + 49 (0)7483 / 91278 - 0
Fax: + 49 (0)7483 / 91278 - 15

FRANK SEGULA
Geschäftsführung / Management
Phone: -12 Mail: fs@segula.de

KARIN GRAF
Verkauf Deutschland / Sales Germany
Phone: -21 Mail: kg@segula.de

ELKE KRAMBERGER
Verkauf Deutschland / Sales Germany
Phone: -17 Mail: ek@segula.de

GERHARD KEPPLER
Verkauf International / Sales International
Phone: -16 Mail: gk@segula.de

CARMEN SAHM
Prokuristin / Proxy Holder
Phone: -20 Mail: cs@segula.de

ADELHEID PANNEWITZ
Qualitätsmanagement / Quality Management
Phone: -10 Mail: ap@segula.de

ROBERTO SEGUIN
Key Account Management
+49 (0)172 / 437 675 2 rs@segula.de

FRANK PISTORIUS
Außendienst Lampenfachhandel / Field Service
+49 (0)177 / 307 87 21 fp@segula.de

ZENTRALE / HEADQUARTER

DEUTSCHLAND / GERMANY

SEGULA GMBH
Bergwiesenäcker 15
D-72160 Horb

Phone: + 49 (0)7483 / 91278 - 0
Fax: + 49 (0)7483 / 91278 - 15
info@segula.de
www.segula.lighting

NIEDERLASSUNGEN / SUBSIDIARIES

HONG KONG

SEGULA ASIA Ltd.
Unit 701, The Workstation
43 Lyndhurst Terrace
Central, Hong Kong

hk-sales@segula.de
www.segula.lighting

SCHWEIZ / SWITZERLAND

SEGULA GMBH
Griesernweg 50
CH-8037 Zürich

Phone: +41 44 / 440 43 34
info@segula.ch
www.segula.ch

DISTRIBUTOREN / DISTRIBUTORS

BENELUX FRANKREICH / FRANCE

QUALITY LEDS
Nijverheidsstraat 18
2570 DUFFEL

Phone: +32 (0) 15 63 13 39
info@segula.be
www.segula.lighting

ÖSTERREICH / AUSTRIA

PROFI-IDEE LED GMBH
Florian-Berndl-G. 6
AT-1220 Wien

Phone: +43 (0) 664 2810343
office@segula.at
www.profi-idee.com

GROSSBRITANNIEN / UK

AURALED UK LTD
Unit 2, Cromwell Trading Estate
Cromwell Road - Bredbury

Phone: +44 (0)161 494 2118
sales@auraled.co.uk
www.auraled.co.uk



Become a
SEGULA
Distributor
now!

DISTRIBUTOREN / DISTRIBUTORS

SCHWEDEN / SWEDEN

BELLALITE AB
Mörners väg 122
SE-352 46 Växjö

Phone: +46 10 470 02 00
info@bellalite.se
www.segula.lighting

DÄNEMARK / DENMARK

IMPO TRADING A/S
Havnegade 50
5000 Odense C

Phone: +45 66 14 60 24
info@impotrading.dk
www.segula.lighting

NORWEGEN / NORWAY

PROLYS AS
Østlifaret 9
1476 RASTA

Phone: +47 67 92 09 00
order@prolys.no
www.prolys.no

SPANIEN, PORTUGAL / SPAIN

THERMO LAMP SL
Calle Arganzuela 18
28005 Madrid SPAIN

Phone: +34 645 42 84 97
info@thermolamp.com
www.thermolamp.com

IRLAND / IRELAND

CLICK LITEHOUSE
18 Corrig Road, Sandyford Ind. Estate
Dublin D18 WV79 - IRELAND

Phone: +353 (1) 2811 122
sales@clicklighthouse.ie
www.clicklighthouse.ie

ISLAND / ICELAND

S.GUDJONSSON EHF
Smidjuvegur 3
200 Kopavogur, Iceland

Phone: +354-520-4500
sg@sg.is
www.segula.lighting

RUSSLAND / RUSSIAN FEDERATION

D-LIGHT
Prozed Solomennoy Storizhki, 5
RUS-127206 MOSCOW-RUSSIA

Phone: +7-905-541-44-11
w.d@d-lightcompany.ru
www.d-lightcompany.ru

AUSTRALIEN / AUSTRALIA

BELLA & HUNT LIGHTING
17-21 Little Oxford St.
AUS-VIC 3066 Collingwood
Australia

Phone: 0061 412 276 063
info@bellahunt.com.au
www.bellahunt.com.au

ARGENTINIEN / ARGENTINA

PALMA HNOS.
C. Pellegrini 1051 - CP 1009
Buenos Aires
Argentina

Phone: +54 11 66135 424
jmp@segula.lighting
www.segula.lighting

UNITED ARAB EMIRATES

XOLIGHTS
Green Tower, Office 1504
Rigat Al Buteen, DEIRA
Dubai, UAE

Phone: +971 4 2958818
info@xocompany.org
www.xocompany.org

LIBANON / LEBANON

PROGRESS SMART SYSTEMS SAL
Pharaon bldg facing EDL, 53 Papinien
Al Nahr Street, P.O.Box 11-1111
Beirut - Lebanon

Phone: +961.1.444664
Phone: +961.1.443175
Fax: +961.1.561880
lighting@progresselectric.net

KATAR / QATAR

PROGRESS BUILDING
MATERIALS QATAR W.L.L.
Bin Omran C-ring road
Iskan Headquarter, 1st Floor
P.O. Box 23047, Doha - Qatar

Phone: +974.4451.95.93
Phone: +974.4492.91.64
Fax: +974.4481.80.03
qatar@progresselectric.net

KUWAIT

KUWAIT ELECTRICAL WIRING
ACCESSORIES COMPANY W.L.L.
Building # 30, 31 & 32, Block 6
East Ahmadi Industrial Area
P.O. Box 46476, Fahaheel 64015
Kuwait

Phone: +965 2398 5580
Fax: +965 2398 5581
sales@keckuwait.com

SEGGULA

Änderungen bei Produkten und technischen Daten vorbehalten. Stand April 2017.

Products and technical specifications are subject to modification without notice. Status as of April 2017.