



Ideal Lifts Guide for Light Gauge Steel Construction



Contents

- 3 **Company Profile**
- 4 **Our Models**
- 5 **Key Benefits of Using the Ideal Lifts Frame System**
- 6 **Lift Frame Shaft Size Range**
- 7 **Data Sheet - IL4-F-630-CNR**
- 8 **Floor Rebate Details**
- 9 **Landing Entrance Section Details**



Company Profile:

Ideal Lifts Limited specialise in OFFSITE passenger lifts solutions designed for modern methods of construction (MMC).

Established in 2003, we have many years' experience in the lift industry, with people who want to 'do things differently'.

People are the core of our business, and we believe in the value of collaborative relationships. At Ideal Lifts, we pride ourselves on offering a partnership approach in which we view ourselves as part of the build team rather than an external supplier. We appreciate the benefits of long-term supplier relationships, reducing overall costs, increasing efficiency and communication, reducing pricing volatility and supply chain consolidation.

Ideal Lifts provide complete solutions which include our innovative Ideal Lifts Frame System. We work with clients from the very start of the process, offering a design and technical support service. Our team can then assist with 'freezing' the lift design details, providing them to the professional team, and with continued technical support ensuring a successful completion to what is usually one of the most complex parts of a build project.

Full details of the company's range of products and technical information can be seen in current literature and on the company website at www.ideallifts.com.

Our passenger lift range are suitable for a variety of applications including residential, education, health care, office buildings, retail and commercial use.

All our products are of high quality, safe and reliable. They comply with current Statutory Regulations, (including European Standards) and those covering Health and Safety (H&S), and Construction Design and Management (CDM).



Why Choose Ideal Lifts?

We care about our clients, providing friendly professional advice to ensure our lifts are fit for purpose, cost effective and reliable.

From 4 to 21 person, with ultra compact installations in traditional build with a unique range of solutions for **OFFSITE** construction such as **Timber Frame**, **Modular** and **Light Gauge Steel** (LGS) using our Ideal Lifts Frame System.

A comprehensive range of lifts with contemporary finishes to suit your building needs.

Our Models

IL2 - The IL2 Pitlow hybrid design offers much of the functionality of a conventional passenger lift, with a fully enclosed cabin and automatic 'one touch' controls. The IL2 is designed to fit in only a 150mm pit and 2800mm headroom. In keeping with EN81-41 the IL2 has a drive system designed for low use where speed is not an issue.



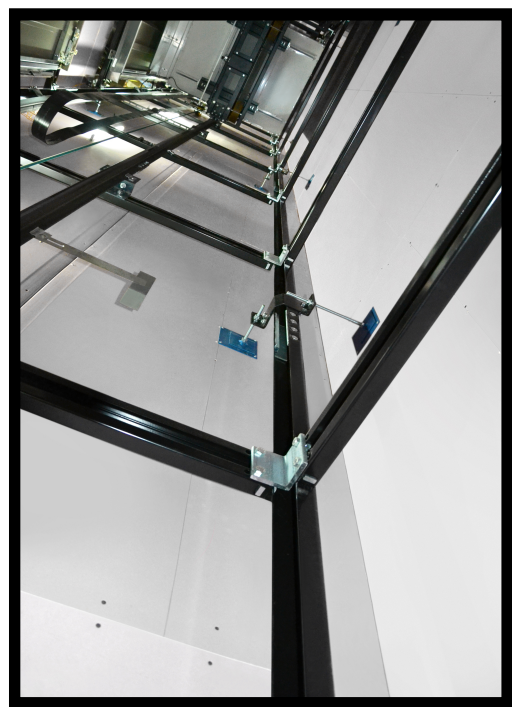

IL3 - The IL3 Eco-Drive motor room-less (MRL) gearless traction drive passenger lift is ideal for low or medium rise buildings and for moderate use. It's a perfect cost-effective and energy efficient solution for your project. Our IL3 ensures a smooth safe ride with low noise, using 35% less electricity and can achieve 2 **BREEAM** credits. A low EN81-20 compliant pit depth can be provided reducing material and construction costs.

IL4 - The IL4 passenger lift range is for larger building and busy environments - to carry people higher and faster. Fitted with a premium variable speed motor room-less (MRL) gearless traction drive, and can achieve two **BREEAM** credits. Our IL4 passenger lifts offer safety, reliability and choice in equal measures. A low EN81-20 compliant pit depth can be provided reducing material and construction costs.

Data sheets detailing shaft, pit and headrooms with loads are available for our range of lifts, please ask for a copy or download these and Auto-CAD plans from our website to assist with your building design.



Key Benefits of Using the Ideal Lifts Frame System:

-  Only requires standard LGS walls
-  No special fabrication or additional steelwork required
-  Speeds up production throughout the factory
-  Includes lifting beams, pit ladder and does not require scaffolding
-  Cost certainty, no waste and speed of installation

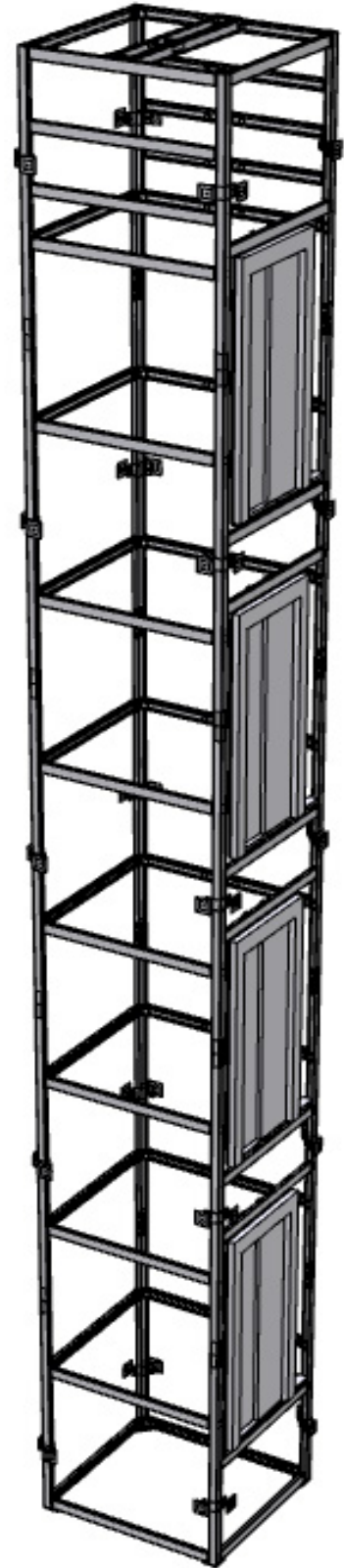

Click on the frame above to see a video overview of the Ideal Lifts Frame System in action.

IL4 Lift Frame Shaft Size Range for LGS Construction:

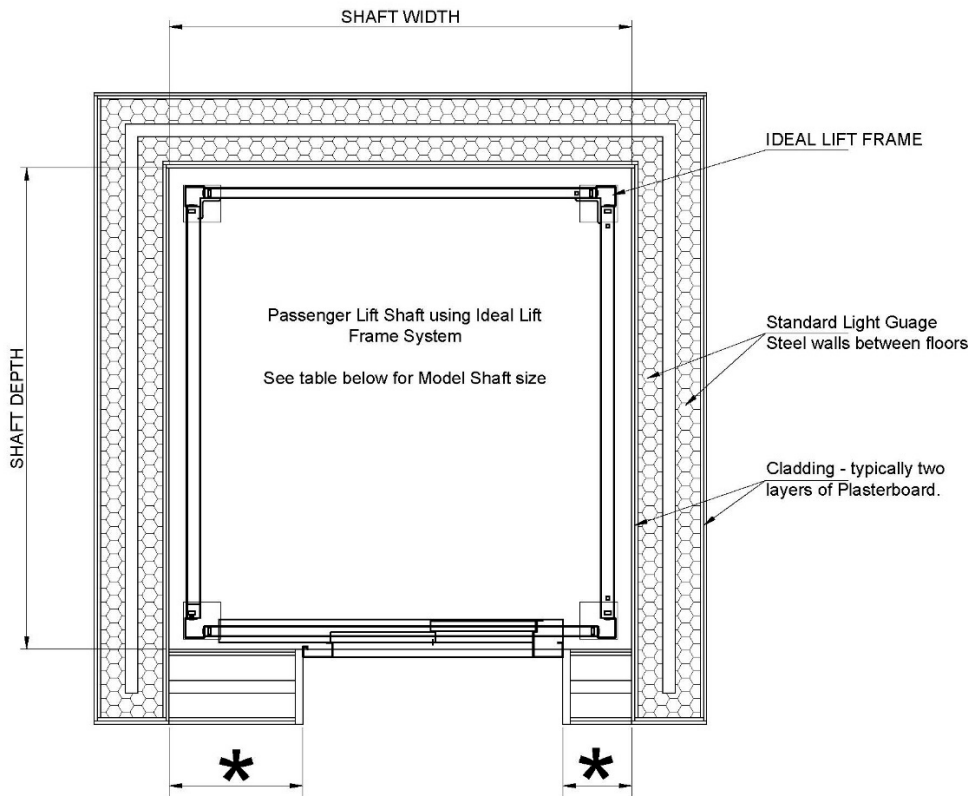

* Refer to specific Builders Work Drawing for Landing entrance Dimensions.

BREEAM Compliant on request

MRL: Motor Room Less

Through Car: Shaft size on request.

Note: Shaft sizes are for guidance purposes only and subject to change. Please contact Ideal Lifts regarding your specific requirement.

We are able to provide an adjacent/90° entry on all our hydraulic and compact gearless traction passenger lifts: shaft size on request.

800mm clear opening doors unless otherwise stated.

Ideal lift frame shaft size table

	Capacity	System	Drive	Shaft Width mm To Plasterboard	Shaft Depth mm To Plasterboard	Pit Depth Below FFL* (EN81-20/50 compliant)	Headroom (overrun) Above FFL
IL3-F-450	6 Person	Hydraulic: 3 panel doors	MRC	1595	1780	1080	3450
IL4-F-450-C	6 Person	Compact Gearless Traction: 3 panel doors	MRL	1595	1780	1080	3650
IL4-F-450-C	6 Person	Compact Gearless Traction	MRL	1650	1740	1080	3650
IL4-F-630-C	8 Person	Compact Gearless Traction	MRL	1700	1900	1080	3650
IL4-F-630-C	8 Person	Compact Gearless Traction: 3 panel doors (900mm)	MRL	1700	1960	1080	3650
IL3-F-630	8 Person	Hydraulic	MRC	1750	1900	1080	3450
IL4-F-630	8 Person	Gearless Traction	MRL	1850	1900	1080	3650
IL3-F-1000	13 Person	Hydraulic	MRC	1895	2640	1080	3450
IL4-F-1000	13 Person	Gearless Traction 2 panel doors (900mm)	MRL	1930	2650	1080	3650

NOTE: All models 800mm doors (2-panel side opening) unless stated.

* Reduced pit depths available on some models, compliant with EN81-20/50. Contact us for details.

Please contact us to discuss additional lift models and sizes not listed above

8 Person 630KG Passenger Lift:

Frame Mounted Lifts - Lifting Beams supplied by Ideal Lifts

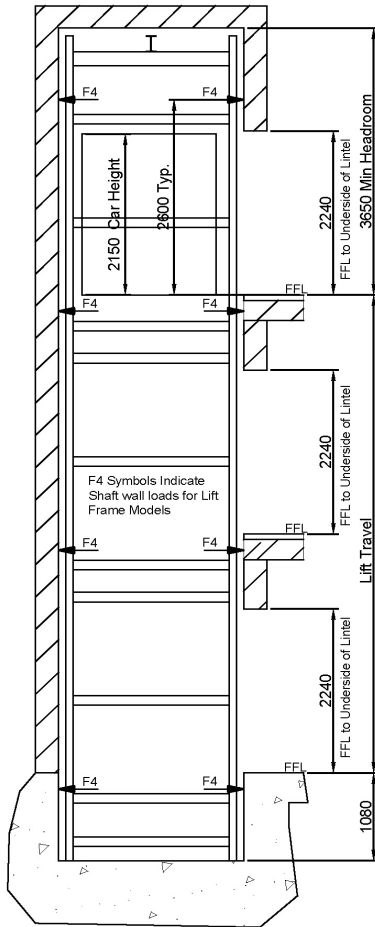

Lift Frame

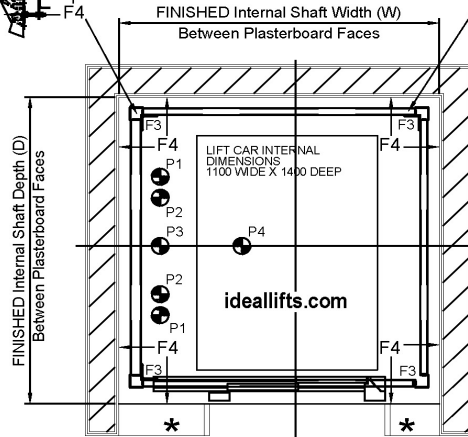

Ideal Lifts 8 Person 800 wide Two Panel Side Opening Doors Lift Plan

Lift Frame

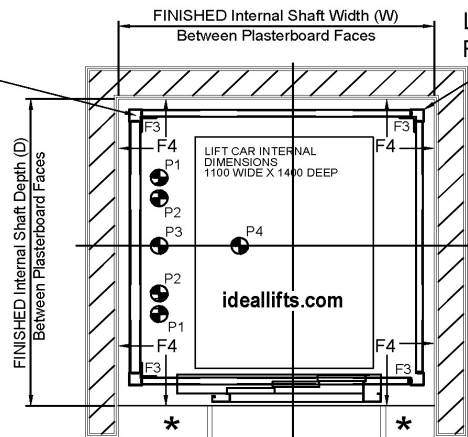

Ideal Lifts 8 Person 900 wide Three Panel Side Opening Doors Lift Plan

* ENTRANCE RETURN WALLS CONSTRUCTED AFTER LIFT ENTRANCE FITTED. LINTEL HEIGHT 2240 ABOVE FFL.

LEFT HAND SLUNG LIFTS DETAILED. RIGHT HAND SLUNG ZERO COST OPTION

LIFT FRAME MODELS UPTO MAXIMUM 21.0 Mtr. TRAVEL.					
LIFT CAR 1100 W X 1400 D X 630Kg		LIFT WELL DIMENSIONS.			
MODEL TYPE.	DOOR TYPE.	SINGLE ENTRANCE		THROUGH CAR	
		W.	D.	W.	D.
IL4 F 630-800 - 2 PSO CNR	800 W X 2000 H - 800 Wide Two Panel Side Opening Doors	1700	1900	1700	1980
IL4 F 630-900 - 3 PSO CNR	900 W X 2000 H - 900 Three Panel Side Opening Doors	1700	1960	1700	2110

NOTE! - For guidance only. Shaft size based upon a maximum shaft height of 18 mtrs. for greater lengths of shaft consult Ideal lifts. Construction to be based upon Site specific Builders work Drawing from Ideal Lifts.

Loads Imposed by 8 Person Compact Lift 800 & 900 Doors

Lift Pit Floor Loads	Lift Frame Models		Type of Loading
	P1	P2	
P1	22 KN		Lift Guide Rail
P2	0.75 KN		Counter Weight Guide Rail
P3	39.5 KN		Counter Weight Buffer
P4	60 KN		Car Buffer
F3	10.0 KN		Lift Frame Feet
F4	1.0 KN		Jacking Bolts

NOTE! Both Lift Types - For guidance only. Loadings will be confirmed upon a Site specific Builders work Drawing from Ideal Lifts.

Data Sheet for - IL4 F 630kg Compact Lift Frame Shaft - Plan and Pit Floor Loads No Rebates

Data Sheet No :-	IL4 F 630kg CNR
Revision No :-	A
Date :-	22-02-2018
Drawn By :-	R S

Tel: 01837 659999
E Mail: info@ideallifts.com
Web: ideallifts.com

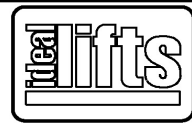

Compliant with Part M of The Building Regulations & EN81-70; 2003 Type 1

No Landing Floor Rebates Required on LGS Construction:

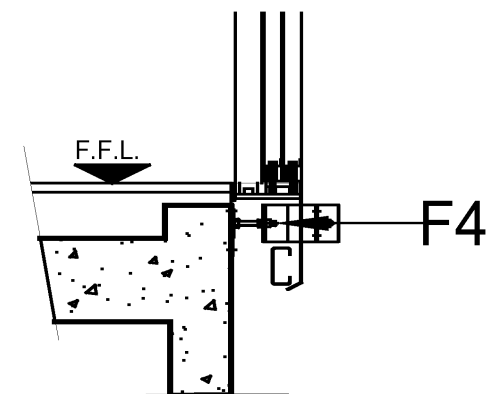
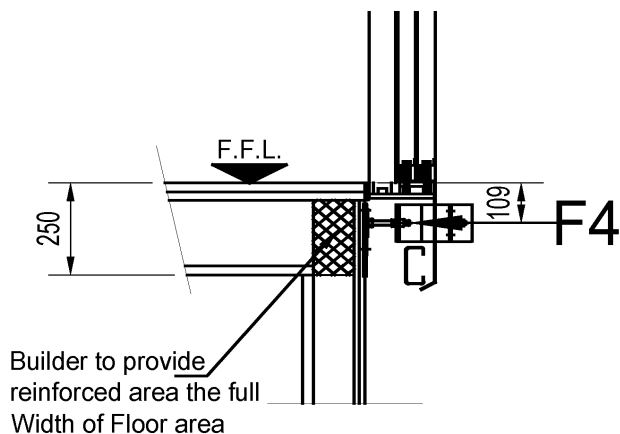

Lift Entrance Details
Concrete Level

Landing Entrance Section Details:

Landing doors fixed directly to the Ideal Lifts frame system and not the LGS building.

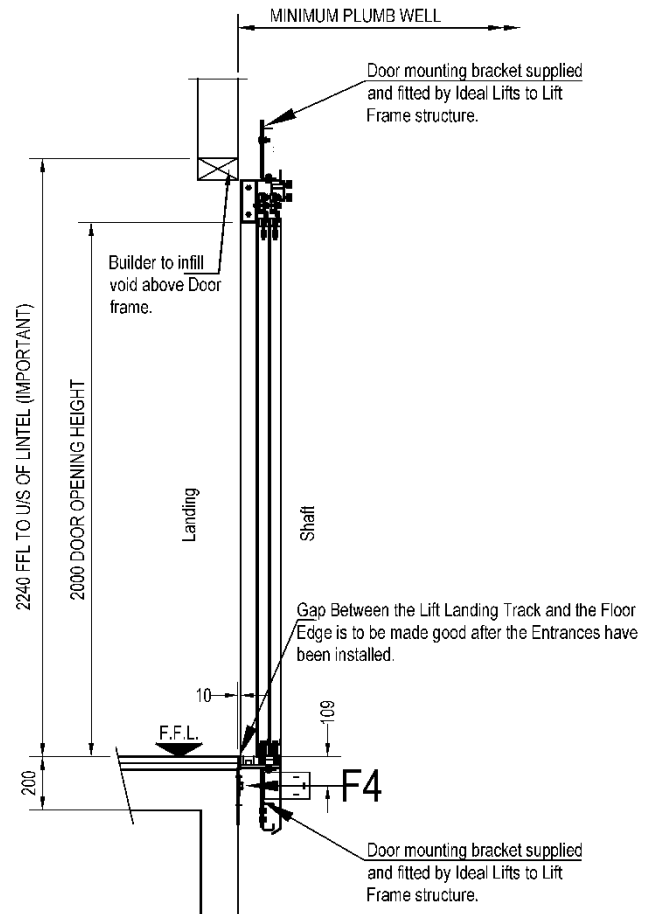
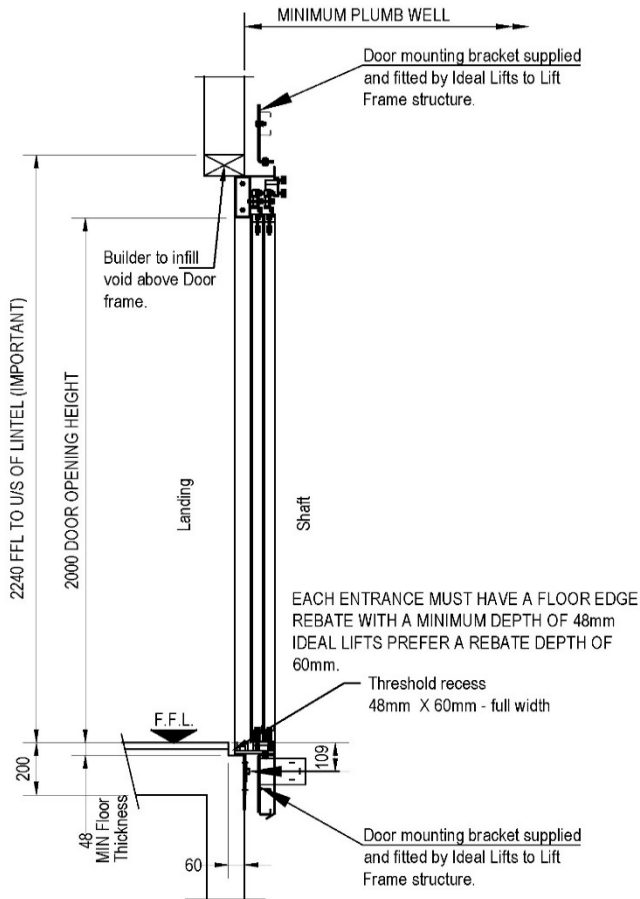

Easier to:

✓ Design

✓ Construct

✓ Manufacture

✓ Fire line

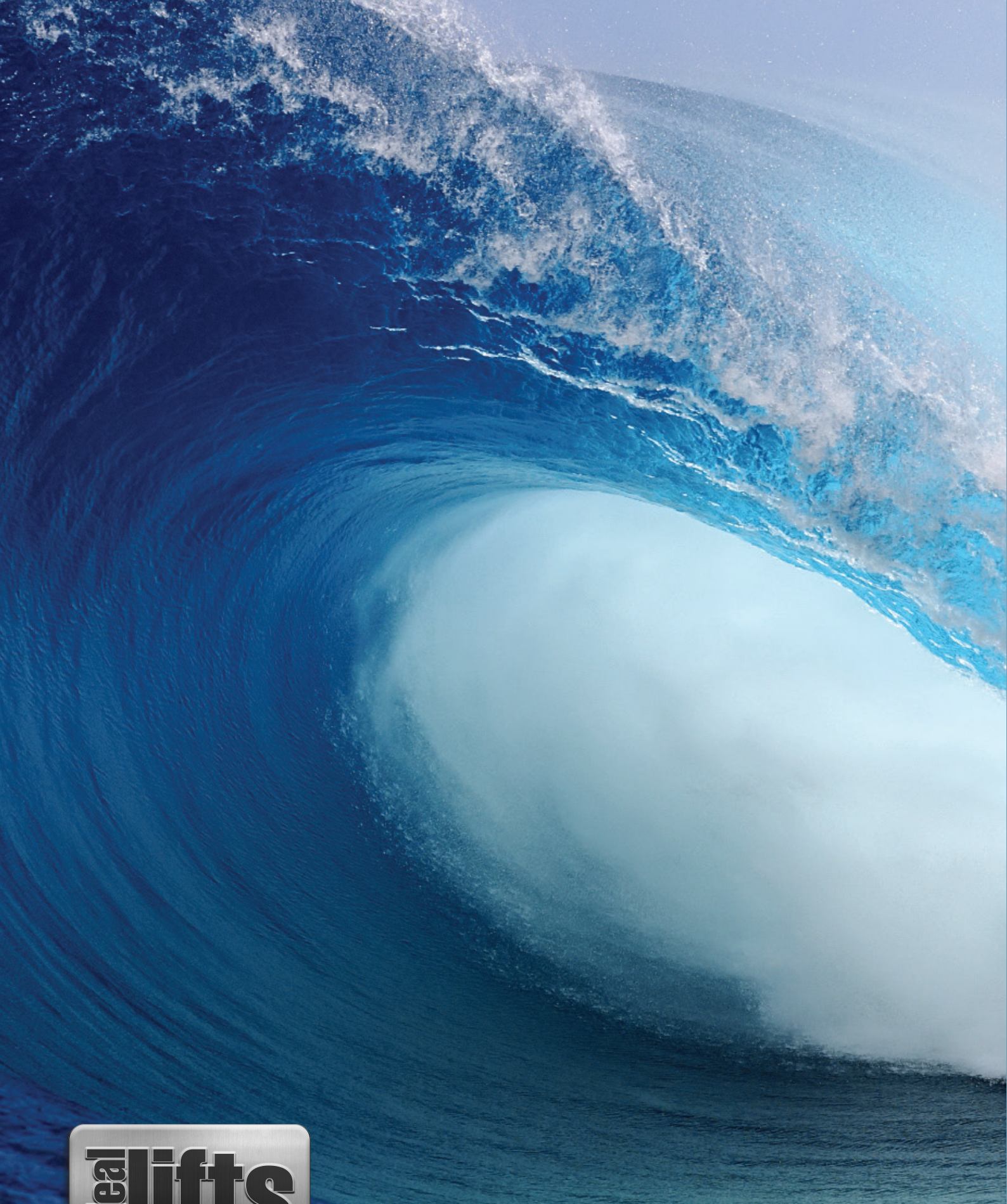

Tel: 01837 659999
 Email: info@ideallifts.com
 Web: ideallifts.com

