

IZO MODEL **612** ELECTRIC

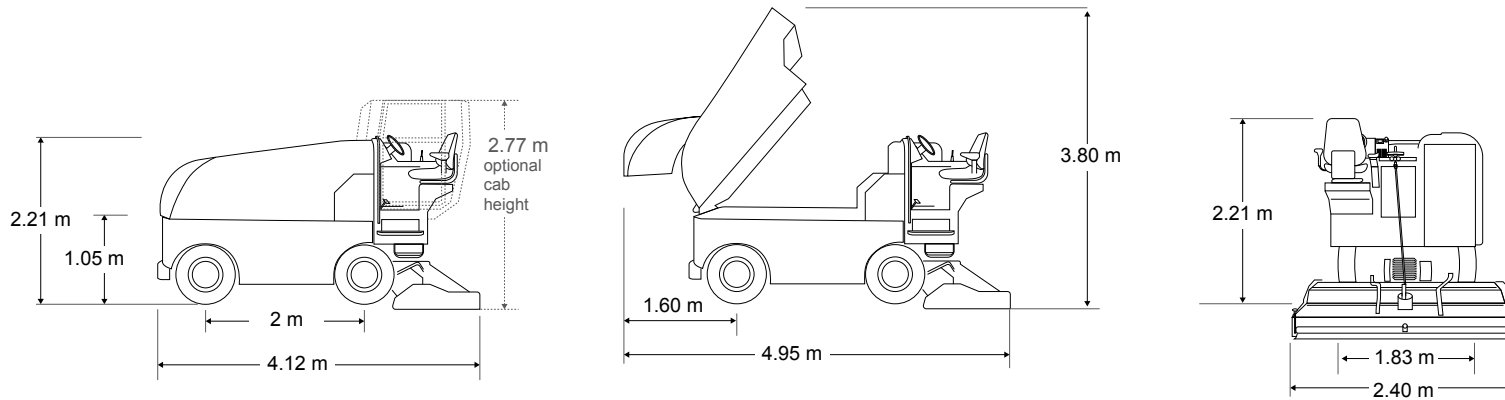

CAPACITIES

Snow Tank

Actual Volume	3.20 m ³	113 cu. ft.
Compacted	4 m ³	141 cu. ft.

Water

Ice Making (larger tank optional)	850 (1000) L	224.5 (264.2) gal.
Wash Water	400 L	106 gal.
Total	1250 L	330 gal.

Hydraulic Oil	22 L	5.8 gal.
----------------------	------	----------

POWERTRAIN

Four-Wheel Drive

Motors

Four Electric Wheel (traction) Motors	3.25 kW	4 HP
Electric Hydraulic Pump Motor	3 kW	4 HP
Two Electric Auger Motors	9 kW	12 HP
Total Energy Consumption of all Motors	34 kW	46 HP

Battery	625 Ah (optional 775 Ah or 840 Ah 80 V)	
----------------	---	--

Axles

Front	7000 kg	15432 lb
Rear	7000 kg	15432 lb

Brakes	Full Hydrodynamic Braking with Front and Rear Drum Brakes	
---------------	---	--

DIMENSIONS

Overall	L	W	H	L	W	H
Snow Tank Down	4.12 m	2.40 m	2.21 m	162 in.	94 in.	87 in.
Snow Tank Up	4.95 m	2.40 m	3.80 m	195 in.	94 in.	150 in.

Shaving Blade

	L	W	H	L	W	H
220 cm 86.6 in. Blade	220 cm	12.7 cm	1.27 cm	86.6 in.	5 in.	0.5 in.
243.8 cm 96 in. Blade	243.8 cm	12.7 cm	1.27 cm	96 in.	5 in.	0.5 in.

Clearance

Minimum Operator Height Clearance	2.31 m	91 in.
Snow Pit Clearance	105 cm	41.3 in.

Conveyor System

Horizontal Auger Diameter	25.4 cm	10 in.
Vertical Auger Diameter	25.4 cm	10 in.
Auger Length	218.4 cm	86 in.

Manueverability

Wheelbase	2.00 m	78.7 in.
Wheel Track	1.80 m	70.9 in.
Turning Radius at Conditioner	3.85 m	12.6 ft.

Weight

Empty	5130 kg	11310 lb
with Water	6380 kg	14065 lb



Enclosed Cab

The enclosed operator cab provides protection from the elements and a safe, comfortable working space. *optional equipment



Zamboni Connect™ System

Monitor consumption and optimize performance with predictive insight and resource management. *optional equipment



Blade Change Assistant

Allows operators to complete a safe and easy blade installation or removal without touching the exposed blade. *optional equipment

IZO MODEL
612
ELECTRIC

STANDARD FEATURES

2 Year Warranty

Adjustable Steering Wheel

Auto Ice Button for an Automated Start and Stop to All Resurfacing Processes

Automated Wash Water Pump Start

Automatic Snow Breaker

Backup Alarm

Battery Watering System

Battery: Lead Acid with 5 Year Warranty

Blade Change Ease of Access From Above

Brushless AC Motors and Controls

Charger Adjusted to Customer Specs and Microprocessor Controlled

Chassis: Strong All Welded Steel Tubing

Closed Wash Water System

Dual Auger Startup

Dynamic Stability and Traction Control

Electric Water Valve Operation

Electric Wheel Motors

Emergency Stop Button

Ergonomic Blade Adjustment Wheel

Four-Wheel Drive

Galvanized Steel Frame Rear Swing Axle

Guide Wheel

Hydraulic All Wheel Braking

Hydraulic Oil Vacuum Pump

Fiberglass Hydraulic Snow Tank Lid

Ice Making Water Level Gauge

Integrated Snow Tank Safety Stand

LED Headlights And Tail Light

Automatic / Manual Ice Making Water Control

Non-Stick Snow Tank Liner

On-Dash Digital System Performance Display

On-Dash View of Wash Water Return Flow

Parking Brake

Power Cylindrical Board Brush

Power Steering

Premium Adjustable / Heated Seat

Premium Spreader Towel

Preset Speed Options For Ice Maintenance, Ice Hockey And Bandy

Replaceable Conditioner Runners

Replaceable Poly Conditioner Side Plates

Safety Valve on Hydraulic Cylinders for Snow Tank and Conditioner

Snow Tank Light and View Panel

Spare Tire and Wheel

Speed-Related Ice Making Water System

Stainless Steel Wash and Ice Making Water Tank

Stainless Steel Water Distribution Pipe

Steering Wheel Spinner Knob

Tire Wash System and Studded Tires

Transparent Auger Viewing Panels

Variable Auger Speed Based on Water Flow

Wash Water Level Gauge

Wash Water to IMW Transfer System

OPTIONS

1000 L Ice Making Water Tank

Auger Washout System

Automated Towel Bar Lift Raises Towel When Water Is Turned Off

[Blade Change System](#)

Cab

Conditioner: 96"

Front Camera

[Level-Ice™](#)

Machine-Mounted Edger

Seatbelt

Spray Boom

Touch Up Paint Kit

[Zamboni Connect™ System](#)

ZAMBONI®

Some features described or shown may be optional at extra cost and prices, colors, materials, specifications and models are subject to change. Some options are required in combination with other options. ZAMBONI and the configuration of the Zamboni® ice resurfacing machine are registered trademarks of Frank J. Zamboni & Co., Inc. © Zamboni 2019 Rev 05/2019