

# **DATWYLER SYSTEM WARRANTY**

## **Fibreoptic Cabling System**

### **Appendix A2-2**

#### **Acceptance Requirements**

##### **Single-mode fiber optic links (SM)**

**February 2016**

# System Warranty



- 1. Scope of application ..... 3
- 2. General requirements ..... 3
- 3. Approved measuring instruments / mode filters (encircled flux) ..... 3
- 4. Increase of Return Loss ..... 3
- 5. Approved attenuation values for permanent links ..... 4
- 6. Permanent link..... 6
- 7. Measuring direction ..... 6
- 8. Calibration..... 6
- 9. Light sources for multimode optical fibres ..... 6
- 10. FO adapters ..... 6
- 11. Test patch cords with single-mode fibres ..... 7
- 12. Cleaning connectors and connector end faces ..... 7
- 13. Visual examination ..... 7
- 14. Documentation / test result..... 8
- 15. Power meter testing - general requirements ..... 9
- 16. Alternative measurement: OTDR (optical time domain reflectometer) requirements ..... 13

# System Warranty



## 1. Scope of application

The following Acceptance Requirements apply to the testing of multimode (MM) fibre-optic permanent links.

The System Warranty is given only for permanent links with known components (Datwyler components).

## 2. General requirements

The acceptance testing of permanent links must be carried out in compliance with DIN ISO/IEC 14763-3.

## 3. Approved measuring instruments / mode filters (encircled flux)

Power meters and OTDR (optical time domain reflectometers) are permitted for testing permanent links.

The measuring instruments used for testing shall be agreed upon with the responsible sales company prior to acceptance testing of the permanent links. The same applies for mode filters (encircled flux) which shall be used.

## 4. Increase of Return Loss

The use of immersion liquid in connectors to increase the Return Loss is generally prohibited in the whole installation.

## 5. Approved attenuation values for permanent links

### Spliced single-mode permanent link

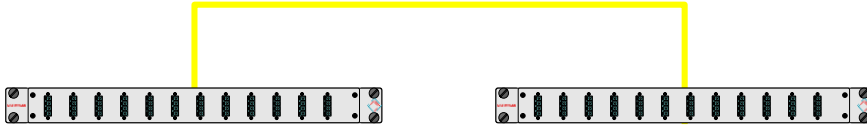

A spliced single-mode permanent link consists following products:

Datwyler FO cable, both sides spliced to Datwyler 19" splice boxes.

The following values apply to OS2 solutions:

- Attenuation ratio fibre:  $\alpha$  0.23 dB/km @  $\lambda$  1550 nm
- maximum value splice loss:  $\alpha_s$  0.10 dB
- maximum value connector loss:  $\alpha_{c1}$  0.50 dB\*

\* Connectors in a data centre environment must fulfil higher performance requirements. These must be clarified before test measurement.

### Maximum attenuation (PASS/FAIL) of spliced permanent links at different lengths:

	Length [m]	Max. [dB] <sup>1</sup>
<b>G.652.D (OS2) <math>\lambda</math>1550 nm</b>	≤ 100	<b>0.9</b>
	≤ 300	<b>1.0</b>
	≤ 500	<b>1.1</b>
	≤ 1'000	<b>1.2</b>
	≤ 1'500	<b>1.3</b>
	≤ 2'000	<b>1.4</b>
	≤ 2'500	<b>1.5</b>
	≤ 3'000	<b>1.6</b>
	≤ 3'500	<b>1.8</b>
	≤ 4'000	<b>1.9</b>
	≤ 4'500	<b>2.0</b>
	≤ 5'000	<b>2.1</b>

<sup>1</sup> rounded to the nearest integer

# System Warranty



## Pre-assembled breakout single-mode permanent link

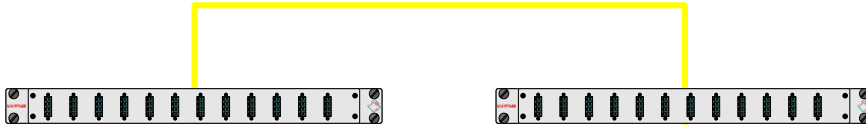

A pre-assembled breakout single-mode permanent link consists following products:  
Datwyler FO cable with pre-assembled connectors on both sides, connected to Datwyler 19" breakout boxes.

Following values apply for OS2 solutions:

- Attenuation ratio fibre:  $\alpha$  0.25 dB/km @  $\lambda$  1550 nm
- maximum value connector loss:  $\alpha_{C1}$  0.50 dB\*

\* Connectors in a data centre environment must fulfil higher performance requirements. These must be clarified before test measurement.

### Maximum attenuation (PASS/FAIL) of spliced permanent links at different lengths:

	Length [m]	Max. [dB] <sup>1</sup>
<b>G.652.D (OS2) <math>\lambda</math>1550 nm</b>	≤ 100	<b>0.7</b>
	≤ 300	<b>0.8</b>
	≤ 500	<b>0.85</b>
	≤ 1'000	<b>1.0</b>
	≤ 1'500	<b>1.1</b>
	≤ 2'000	<b>1.2</b>
	≤ 2'500	<b>1.35</b>
	≤ 3'000	<b>1.5</b>
	≤ 3'500	<b>1.6</b>
	≤ 4'000	<b>1.7</b>
	≤ 4'500	<b>1.85</b>
	≤ 5'000	<b>1.95</b>

<sup>1</sup> rounded to the nearest integer

## 6. Permanent link

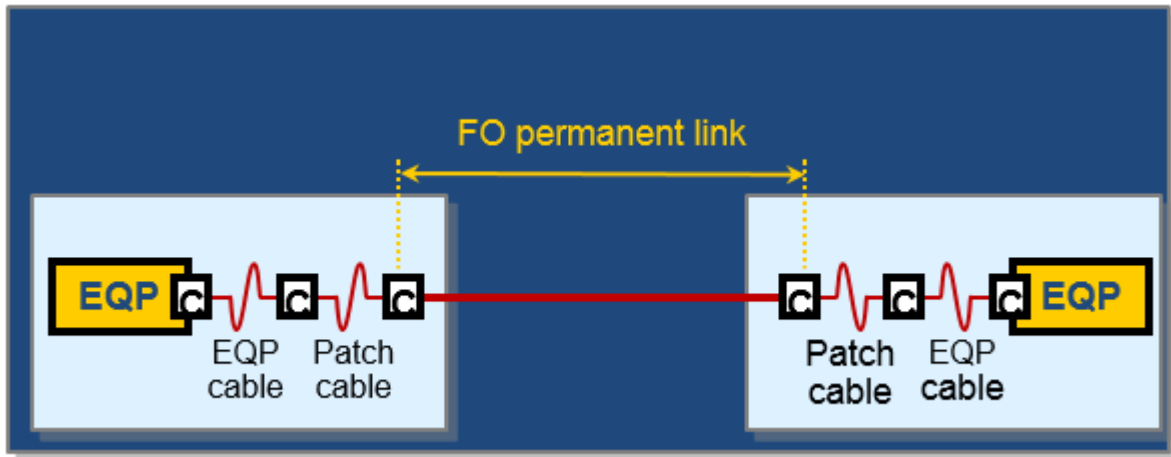

Sample of Permanent Link (EQP=equipment, C=connection)

The permanent link consists the installed cable and the connectors on both ends, without patch cords.

## 7. Measuring direction

### Power meter:

The measurement has to be carried out at wavelength of 1550 nm.

The testing of permanent links in one direction is sufficient.

The measurement in one direction has to be carried out from the same side for all links.

### OTDR:

The measurement has to be carried out at wavelength of 1550 nm.

OTDR measurements have to be carried out from both sides.

Take the mean value of both readings.

## 8. Calibration

Valid calibration certificates must be submitted guaranteeing that the measuring instruments used are sufficiently accurate at the time of measurement (see also Appendix A3-2).

## 9. Light sources for multimode optical fibres

The spectral characteristics of measuring instrument light sources should conform to the table below.

Median wavelength nm
1 550 ± 30

## 10. FO adapters

The FO adapters used for test setup must have reference quality. The reference FO adapters have to be the same type as the FO adapters of the cabling to be tested.

# System Warranty



## 11. Test patch cords with single-mode fibres

The connectors of test patch cords used must have reference quality. The fibres of patch cords used must have the same core diameter as the fibres of the installation to be measured.

## 12. Cleaning connectors and connector end faces

All the connectors and couplings used as well as all the connector end faces on the test patch cords used for measurement should be cleaned prior to testing. Cleaning should be repeated each time the connection is changed.

## 13. Visual examination

Prior to each measurement, all the cleaned connections should be examined with an appropriate microscope. The connector end faces should also be subject to visual examination. The core area of the connector must be free from scratches and specks which do not meet the requirements of the table below.

Impurities are not allowed.

### Examination of connector end faces

Multimode connectors according IEC 61300-3-35

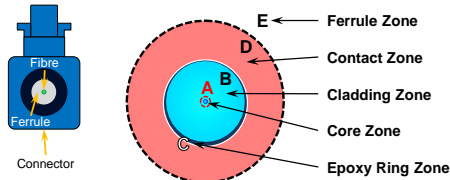

### SM Connector PC (RL ≥ 26 dB)

Zone	Durchmesser	Description	Scratches	Defects
A	0 µm – 25 µm	Core zone	2 ≤ 3µm none > 3µm	2 ≤ 3µm none > 3µm
B	25 µm – 120 µm	Cladding zone	3 > 3µm	5 x 2µm - 5µm none > 5µm
C	120 µm – 130 µm	Epoxy ring zone	no limit	no limit
D	130 µm – 250 µm	Contact zone	no limit	none ≥ 10µm
E		Ferrule zone	not specified	not specified

## SM Connector APC

Zone	Durchmesser	Description	Scratches	Defects
A	0 $\mu\text{m}$ – 25 $\mu\text{m}$	Core zone	$\leq 4$	none
B	25 $\mu\text{m}$ – 120 $\mu\text{m}$	Cladding zone	no limit	5 x 2 $\mu\text{m}$ - 5 $\mu\text{m}$ none > 5 $\mu\text{m}$
C	120 $\mu\text{m}$ – 130 $\mu\text{m}$	Epoxy ring zone	no limit	no limit
D	130 $\mu\text{m}$ – 250 $\mu\text{m}$	Contact zone	no limit	none $\geq 10\mu\text{m}$
E		Ferrule zone	not specified	not specified

### 14. Documentation / test result

The measurement logs of the permanent links tested should be provided in electronic form in the manufacturer's appropriate format.

For each parameter the documentation submitted should state:

1. parameter identification and particulars;
2. testing instrument:
  - type and manufacturer
  - serial number and calibration status
  - nominal wavelength
3. particulars of measured permanent link  
(Datwyler cable number, length, diameter of fibre, fibre type, connector type)
4. the cabling setup during referencing and testing
5. the test result (value and Pass/Fail result)
6. Documentation (pictorial schematic of installation in Appendix A3, including the list of Datwyler products)
7. particulars of reference number and measurement direction (corresponding to pictorial schematic)
8. date of testing
9. the inspector



## 15. Power meter testing - general requirements

### Measurement uncertainty / resolution - power meter

Measuring instrument	Measurement uncertainty	Resolution
Power meter	$< \pm 0.02 \text{ dB}$	Two decimal places

### Approved test setups

The following test setups are approved for power meter testing:

#### “1-Cord Reference Method“ (preferred measurement method)

##### Step 1 Reference Measurement P0:

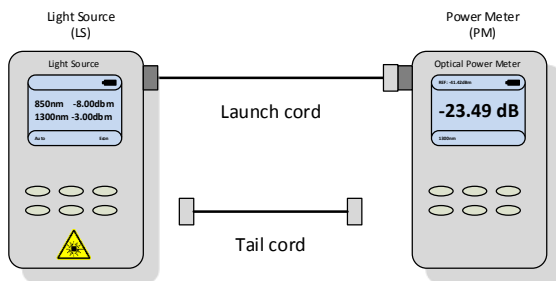

##### Step 2 Intermediate Measurement:

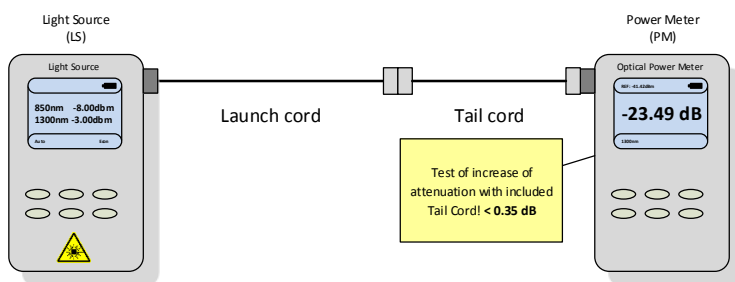

##### Step 3 Test Measurement P1:

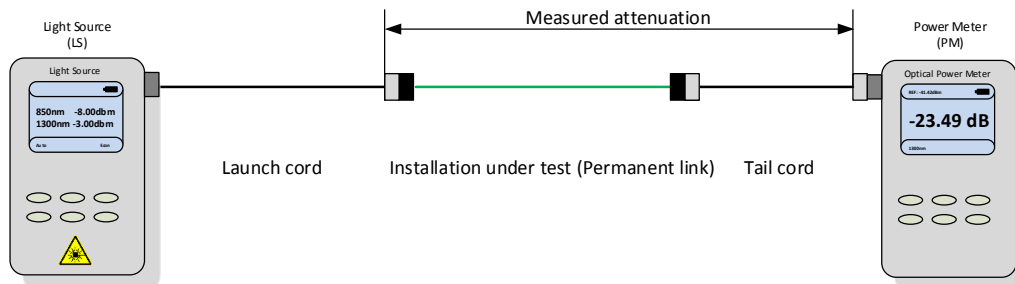

### Test patch cords

# System Warranty



The test cords used must have reference quality and contain fibres with nominal values identical to those of the fibres to be tested.

The test cords consist launch cord and tail cord.

## **Length of test cords:**

### **Launch cord:**

- length: 1 m to 5 m

### **Tail cord:**

- length: 1 m to 5 m

Launch Cord and tail Cord should be made of pre-assembled patch cords which have their own reference connectors, are suitable for connecting to the cabling to be tested, and are compatible with the measuring instruments.

## **Using launch and tail cords**

A zero adjustment should be carried out with launch cord inclusive the encircled flux. At the intermediate test with connected launch cord and tail cord, the increase of attenuation should not exceed 0.35 dB.

The permanent link to be tested (test P1) must be inserted between launch cord and tail cord. The test result of P1 must be recorded in dB. Launch cord and tail cord have to be connected to the light source and power meter while measuring the permanent links.

To prevent from incorrect measurement, the reference setting P0 has to be performed again after 250 measurements in maximum.

Test cords have to be replaced at a deviation of  $\geq 0.35$  dB.

A reference measurement has to be performed after every turn off of the measurement instrument.

## **Handover of measurement files – Pass/Fail**

The measurement files have to be forwarded in original file format of measurement instrument manufacturer. The measurement values have to be entered in Appendix A3-2 Table 3.1b.

## “2-Cord Reference Method“ (alternative method of measurement)

### Step 1 Reference Setting P<sub>0</sub>:

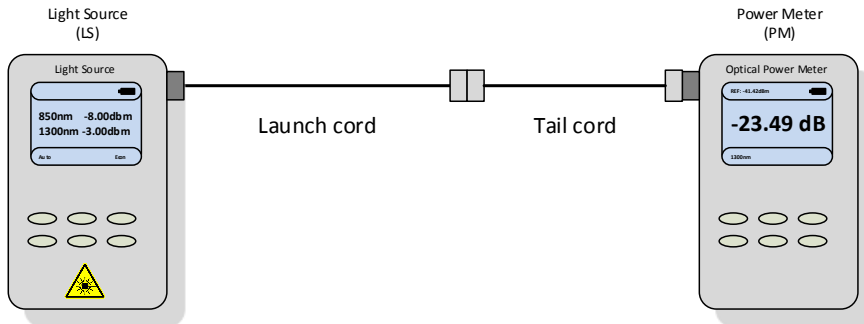

### Step 2 Test Measurement P<sub>1</sub>:

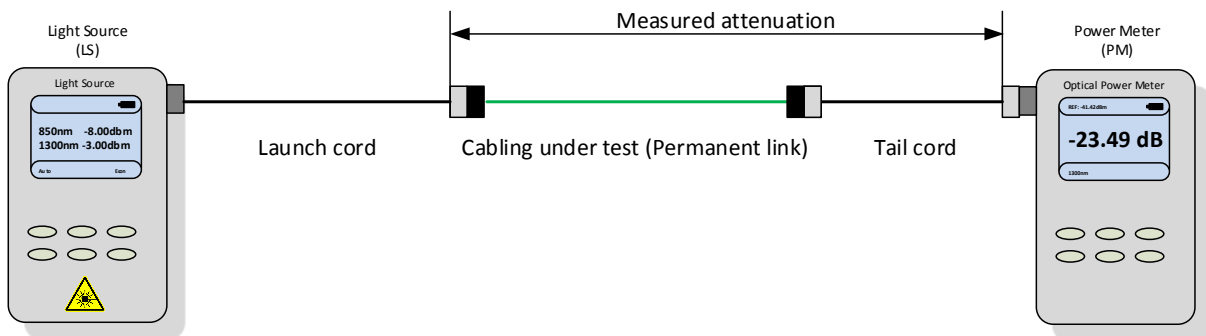

### Test patch cords

The test cords used must have reference quality and contain fibres with nominal values identical to those of the fibres to be tested.

The test cords consist launch cord and tail cord.

### Length of test cords:

#### Launch cord:

- Length: 1 m to 5 m

#### Tail cord:

- Length: 1 m to 5 m

For launch cord and tail cord should be made of pre-assembled patch cords which have their own reference connectors, are suitable for connecting to the cabling to be tested, and are compatible with the measuring instruments.

# System Warranty



## **Using launch and tail cords**

A zero adjustment should be carried out with launch cord and tail cord. The permanent link to be tested (test P1) must be inserted between launch cord and tail cord. The test result of P1 must be recorded in dB. Launch cord and tail cord have to be connected to the light source and power meter while measuring the permanent links.

To prevent from incorrect measurement, the reference setting P0 has to be performed again after 250 measurements in maximum.

Test cords have to be replaced at a deviation of  $\geq 0.35$  dB.

A reference measurement has to be performed after every turn off of the measurement instrument.

## **Handover of measurement files – Pass/Fail**

The measurement files have to be forwarded in original file format of measurement instrument manufacturer. The measurement values have to be entered in Appendix A3-2 Table 3.2b.

## 16. Alternative measurement: OTDR (optical time domain reflectometer) requirements

### Approved test setups

Only testing with launch cord and tail cord is approved for OTDR measurement.

The following test setups should be complied with when using an OTDR to measure permanent links.

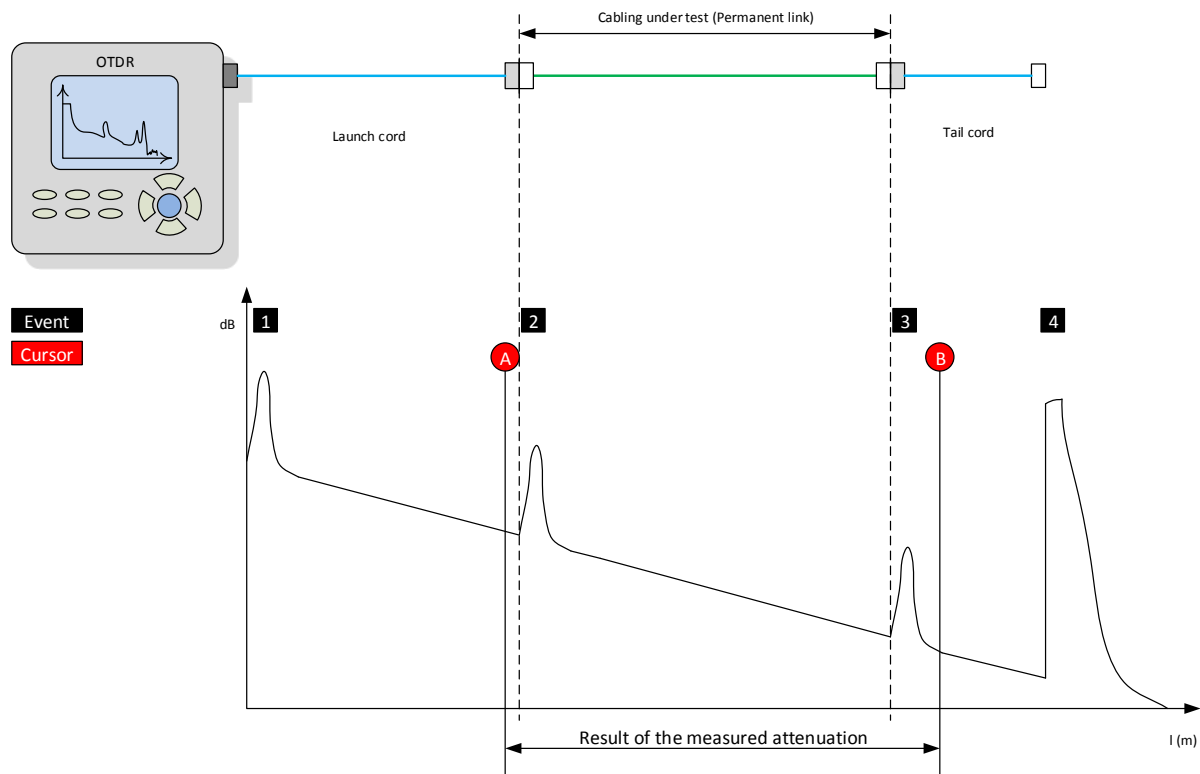

### Test patch cords (launch cord and tail cord)

The test cords used must have reference quality and contain fibres with nominal values identical to those of the fibres to be tested.

The test cords below are used in the test setup.

#### Launch cord:

- Longer than the attenuation dead zone of the OTDR, at least 150 m

#### Tail cord:

- Longer than the attenuation dead zone of the OTDR, at least 150 m

Launch cord and tail cord should be pre-assembled patch cords which have their own reference connectors, are suitable for connecting to the cabling to be tested, and are compatible with the measuring instrument.

Spliced Cable Pigtails are not allowed.

# System Warranty



## **Dual-ended measurement (A-B, B-A)**

The attenuation/insertion loss of the permanent link is determined by measuring in both directions and calculating the mean value of the two results.

## **Handover of measurement files – Pass/Fail**

The measurement files have to be forwarded in original file format of measurement device manufacturer.

The measured values for A-B and B-A measurement have to be entered in Appendix A3-2 Table 3.3.b.