

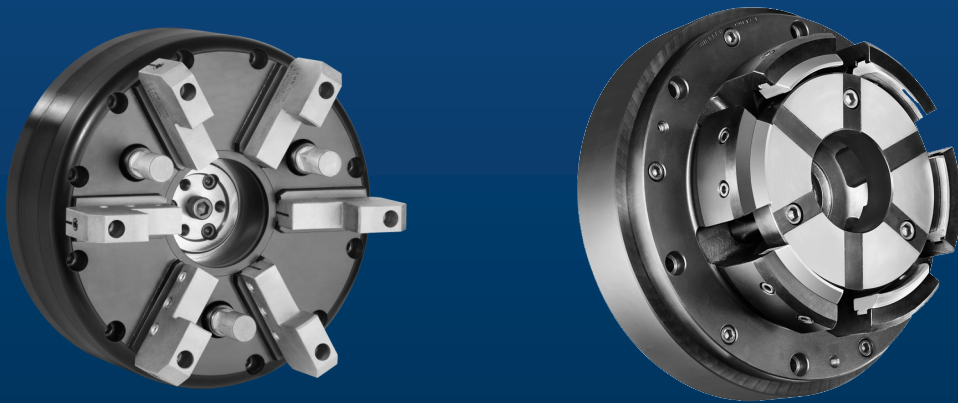

**INSTALLATION AND SERVICE INSTRUCTIONS
FOR DIAPHRAGM CHUCKS**



WWW.FORKARDT.US

A diaphragm chuck is a precision tool. It will produce parts to tolerances closer than ever produced on a production bases. Accuracy, simplicity, and sturdiness are the foundation of its performance. It should be treated as a precision tool and not abused with hammers and ill-fitting wrenches.

How A Diaphragm Works With a Built –in Cylinder

Air is introduced through the spindle and adapter plate by means of a 1/4" pipe. When air pressure is applied, the piston moves forward about .030"; and the movement is transmitted to the diaphragm by a push sleeve. As the diaphragm is flexed the jaws open and the workpiece is loaded. To chuck, the air is turned OFF, and the jaws move toward the relaxed position until jaw contacts the part. Part is located on center. Consistent concentricity is controlled to a maximum runout of 1/3 of part tolerance.

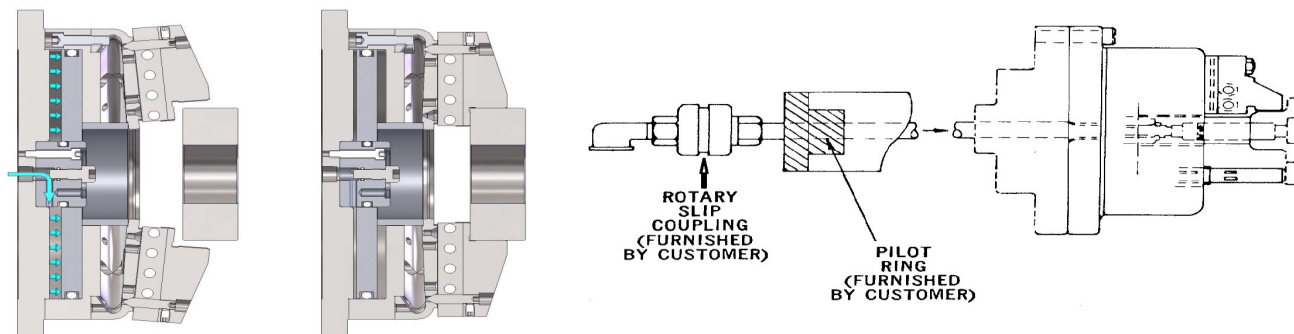

INSTALLATION TO SPINDLE WITH DRAWBAR

1. Make sure spindle face is clean.
2. Mount sub-adapter **securely** to machine spindle.
3. Position machine drawbar in full forward position.
4. Mount basic chuck assembly (no tooling) with actuation assembly to sub-adapter by rotating the chuck clockwise until drawbar adapter locks out. Then turn the chuck counter clockwise until timing pin is aligned correctly to chuck body.
5. Position machine drawbar in fully retracted position and install mounting bolts **securely**.
6. Open and close the chuck to make sure there is enough of an opening provided to load the work piece and that there is enough over-travel of the inserts to properly chuck the workpiece.
7. Back off mounting screws and snug them to the diaphragm.
8. (If Applicable) Using the set screws spaced around the O.D. of the sub-adapter, indicate the master to run true.
9. Tighten the chuck mounting screws **securely**.

Chucking Plain Diameters

1. Turn air "ON" and regulate to approximately 65 P.S.I. (or as shown on included prints).
2. Finish turn or grind jaws and work stops in position to assure concentricity with spindle.
3. Concentricity should not be more than .001 T.I.R. between:
 - a. spindle mount
 - b. ground O.D. of Diaphragm
 - c. work stops
 - d. locating diameter (jaws)
4. Increase air pressure just enough to permit easy loading of part. Do not open or close more than necessary otherwise, dust, grit, or foreign particles adhering to the part will affect the accuracy of the chuck. Properly adjusted, the work piece will actually "wipe" the jaws and itself clean as it is inserted.
5. With work piece in place, turn air "OFF." The jaws will grip the part securely in alignment with the work stops, and on center.

Chucking Pitch Diameters

1. Indicate ground O.D. of diaphragm to run .0005" or better.
2. Turn air "ON" and regulate to approximately 40 PSI
3. Adjust gear pins to grip master part tight and true by sight.
4. Lock all clamp screws on front of jaw blocks, snugly, but not tightly.
5. Raise air pressure to 65 PSI. Master gear can now be removed.
6. Check the dial indicator on nose of gear pins and adjust the pins inwardly for external chucking and outwardly for internal chucking so that they are uniform within .0002" and so that the master gear can be just barely inserted. With the master gear in place, flip the air valve "OFF" and "ON" several times so the gear pins align themselves to the gear teeth and seat firmly. With gear in place and air OFF, lock all clamp screws on front of jaw blocks tightly. Turn air ON, remove master jaw, and chuck again.

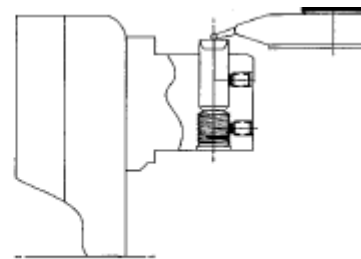
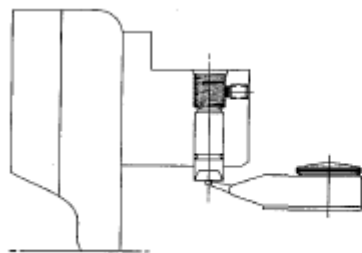

NOTE: AFTER DIRECTIONS ABOVE HAVE BEEN CAREFULLY CARRIED OUT, AND *IF FOR ANY REASON*, (SUCH AS INCORRECT SPACING OF GEAR TEETH OR WARPED GEAR TEETH) *THE RESULTANT CONCENTRICITY OF PITCH DIAMETER OF THE GEAR WITH THE FINISHED BORE (OR STEM - AS THE CASE MAY BE) IS NOT WITHIN .001 T.I.R., THEN:*

1. Mark one jaw with red grease pencil "X". Also mark the gear directly inside jaw so marked "X".
2. Finish that gear - check the concentricity - *mark the high* reading on gear with grease pencil "H". Produce at *least three* such test gears.
3. Bring these gears back to chuck and analyze, whether all three gears show the high spot "H" at the same position in relation to Jaw marked "X". If they do show the same position, then the jaw (or jaws) directly above "H" should be adjusted inwardly one half of the error of concentricity (USE INDICATOR). Repeat a-b-c until desired concentricity is produced.

RECOMMENDATIONS FOR MACHINING JAWS ON DOVETAIL STYLE DIAPHRAGM CHUCKS

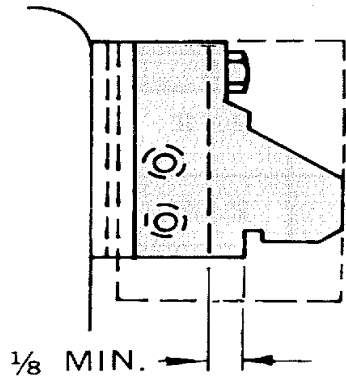

Machine blank jaws as shown and leave 1/8" minimum stock from slot for strength. Remove excess weight to reduce centrifugal force. If fixed stops are not required, receding stop can be machined in jaws. Chamfer leading edge of jaws for each loading.

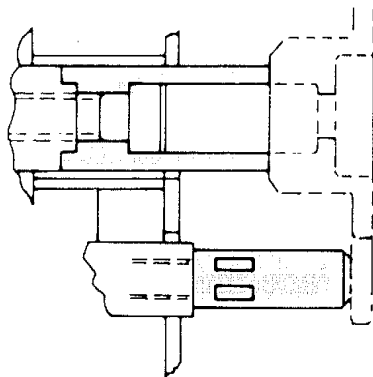

All diaphragm chucks have positive pullback against work stops. For small diameters use center stop to suite and machine in assembly. When using stop studs also machine in assembly.

HIGH SPEED APPLICATIONS

Dynamic balancing is necessary for speeds in excess of 1000 RPM. In some applications special counterweights are required. Contact our sales office for recommendations and pricing.

FRAGILE OR THIN-WALLED PARTS

Surrounding type jaws are often required for these parts. In addition, reduced pressure while machining is possible with differential air control unit. Please contact our sales office for more information.

MAINTENANCE

- ⇒ Keep all stop faces clean from chips and grit.
- ⇒ Blow off inserts and puller cap between parts as often as necessary
- ⇒ Make sure chuck actuates smoothly

PARTS BREAKDOWN

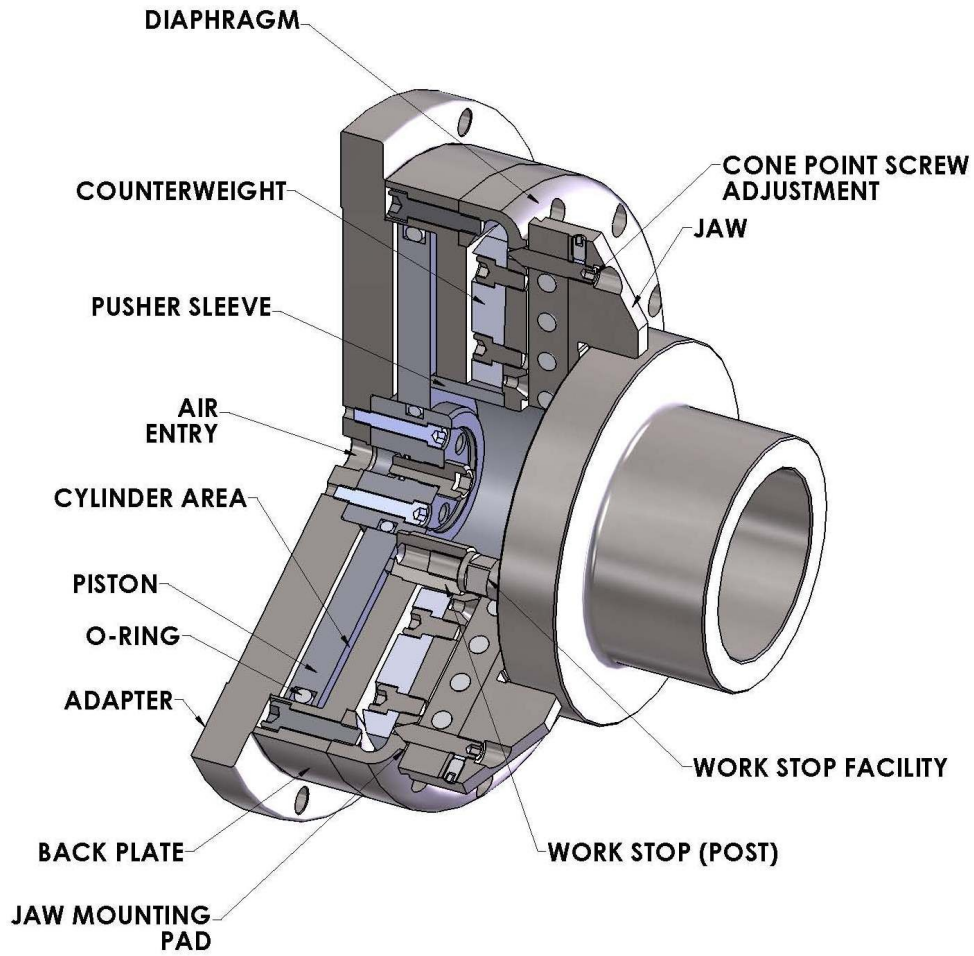

Gear Chucking

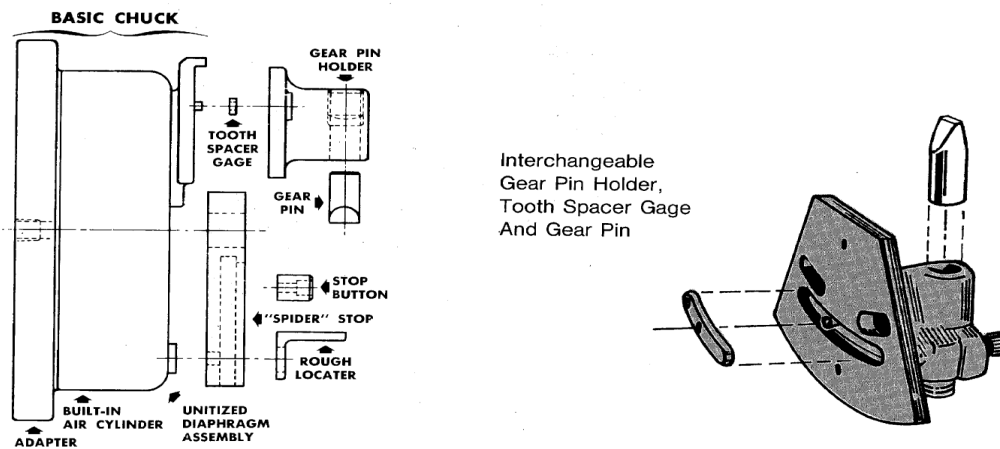

Forkardt Service Department



Paid Repair

The Forkardt service department assesses and repairs all brands currently produced by Forkardt. Customers can send their workholding to the Forkardt plant to receive an assessment for the repairs needed to bring it within original working condition. Any new improvements or revisions to that model will be incorporated into the repair, as if you are receiving a new chuck at a discounted price.

Most estimates are sent within one week of the item arriving at the Forkardt facility. A non-refundable assessment fee may be charged if there are extra ordinary efforts required.

Paid Service

Forkardt service technicians can help install or troubleshoot existing workholding set ups. This allows the customer to be trained and also allows the customer to reallocate resources by letting the experts take care of the product.

Technicians can perform on site training for preventative maintenance, disassembly and repair. This leads to improved and safer performance of the product.

Service technicians can also perform balancing on most brands of chucks in the field. This leads to improved performance of the machine, tooling and product.

Limited Warranty

Forkardt's products are warranted for a period of (1) year from date of delivery to be free from defects in material and workmanship.

This warranty does not include, nor does Forkardt assume responsibility for, defects or damage caused by misuse or abuse, alterations, service or repair by others, wear parts or failure to properly maintain the product.

OEM Serviceable Chucks

- NA Woodworth
- Forkardt
- SP
- Sheffer
- Logansport
- Buck Chuck
- Tork-Lok
- Teikoku

Contacts

- Service Department
(231-995-8348 jhalligan@forkardt.us)
- Inside Sales
(231-995-8348 sales@forkardt.us)

Ship To Address

2155 Traversefield Dr
Traverse City, MI 49686





OUR HISTORY

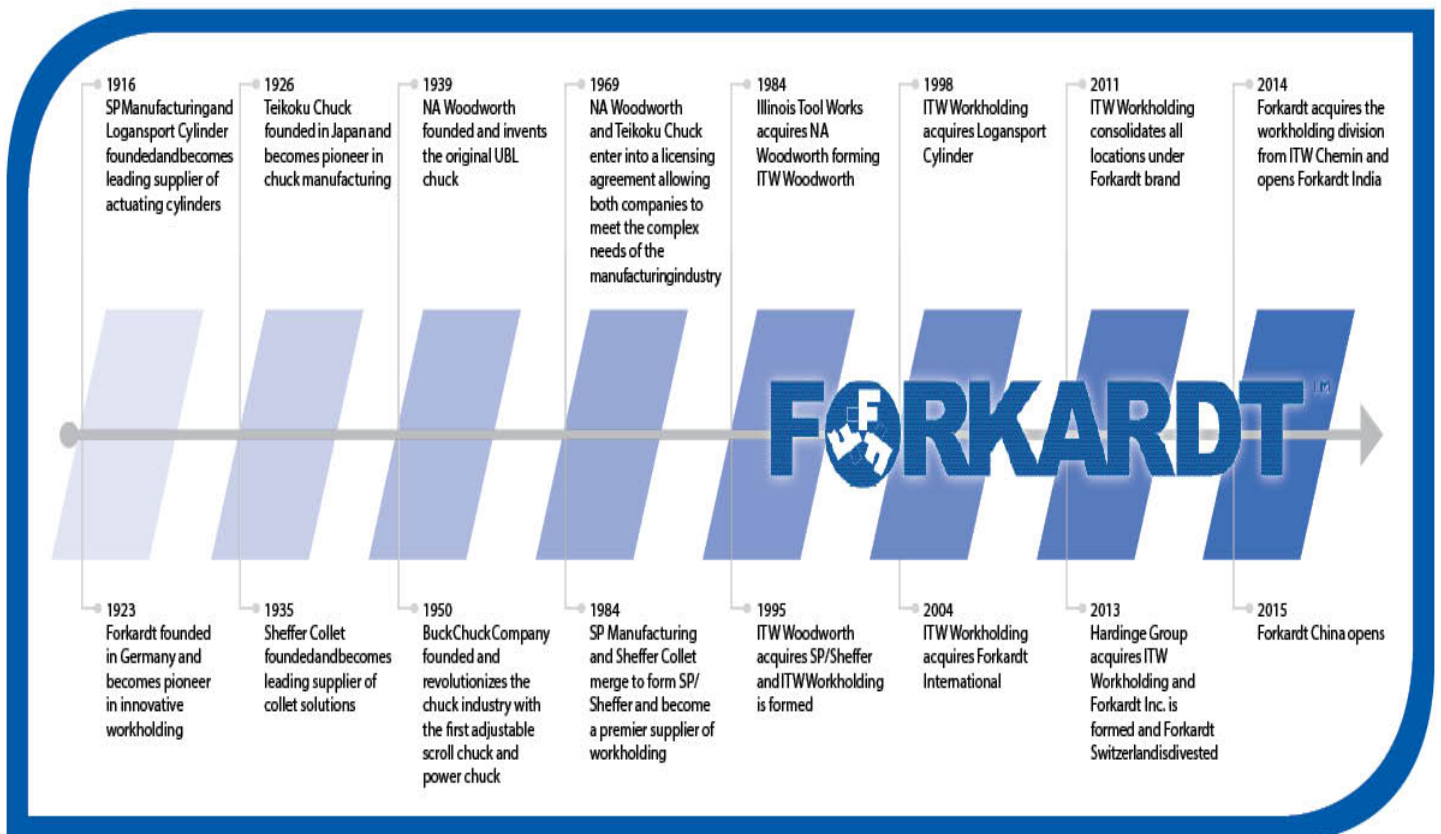

Innovative Technology by **FORKARDT**

L O C A T I O N S W O R L D W I D E

FORKARDT GMBH
 Lachenhauweg 12
 72766 Reutlingen-Mittelstadt
 D-
 Phone: (+49) 211 25 06-0
 E-Mail: info@forkardt.com

FORKARDT USA
 2155 Traversefield Drive
 Traverse City, MI 49686, USA
 Phone: (+1) 800 544-3823
 (+1) 231 995-8300
 Fax: (+1) 231 995-8361
 E-Mail: sales@forkardt.us
 Website: www.forkardt.com

FORKARDT FRANCE S.A.R.L.
 28 Avenue de Bobigny
 F-93135 Noisy le Sec Cédex
 Phone: (+33) 1 4183 1240
 Fax: (+33) 1 4840 4759
 E-Mail: forkardt.france@forkardt.com

FORKARDT CHINA
 Precision Machinery (Shanghai) Co Ltd
 1F, #45 Building, No. 209 Taigu Road,
 Waigaoqiao FTZ CHINA 200131,
 CHINA
 Phone: (+86) 21 5868 3677
 E-Mail: info@forkardt.cn.com
 Website: www.forkardt.com

FORKARDT INDIA LLP
 Plot No. 39 D.No.5-5-35
 Ayyanna Ind. Park
 IE Prasanthnagar, Kukatpally
 Hyderabad - 500 072
 India
 Phone: (+91) 40 400 20571
 Fax: (+91) 40 400 20576
 E-Mail: info@forkardtindia.com

www.forkardt.com