

Collision Deformation Classification



I am writing to enlist the help of all engineers in what has become, for me, a rather long term crusade in respect of engineer reports regarding the description of the impact direction and extent of damage.

I have been trying to get others to follow my lead since 1993/4 when I got back from a course at Miami University and had become a member of the Society of Automobile Engineers Inc.

The method of damage description I advocate is in SAE MAR80 J224, the standard developed by the federal US government for simple description of damage. At the time they had started to run ample new vehicles into unyielding barriers. They used technical students to record the results and used the Collision Deformation Classification code SAE MAR80 J224 CDC.

The Collision Deformation (CDC) code is a seven digit three dimensional code indicating Principal Direction of Force (PDOF). The location of deformation and damage. The vertical location. The type of damage distribution. The maximum

extent of penetration into the vehicle envelope.

The glory of this system is that it removed the currently used system which had become time worn and relied upon by no-one. In the original Blue Book of Automobile Assessing by D Griffiths, published by Butterworths under 'Leading Points of Impact' (pages 16-18), he set out some 12 examples of diagrams indicating:

1. The area of the vehicle which is damaged relating to the centre line
2. Direction of impact which is related to the PDOF – Principal Direction of Force
3. The severity of impact.

Mr Griffiths says such descriptions should be realistic and not exaggerated. It is permissible to qualify comments by adding 'of a heavy nature or very heavy nature'.

Unfortunately most of this has been lost in the midst of time. All we now get is an arrow pointing at a diagrammatic vehicle and a comment which rarely goes beyond 'light', moderate or heavy'. If anyone tries then to use this to establish extent of damage or

continuity of damage between two or more vehicles it is frankly useless and simply downgrades the whole value of the report.

In the CDC code a 12FDEW3 has real meaning. If I am talking to a man in a foreign country, I can get round technical translation by stating the description SAEJ224MAR80 standard and he can then understand 12FDEW3 instead of Mr Griffiths' example (a) page 16 which says "square on the front from front to rear" and then presumably is enhanced by the words "very heavy nature". No-one can define what heavy means in this respect! Now look what you get from a CDC of 12FDEW3.

- 12 = Clock direction of PDOF
- F = Area of deformation
- D = Specific location or lateral area
- E = Specific vertical area
- W = Type of damage distribution
- 3 = Maximum extent of penetration on a scale of 1-10 from extremity to centre of vehicle in the direction of crush.

On the following pages you will see some example codes and I invite all members to join in my crusade.

So my plea is, let us adopt the CDC system for use throughout the profession and stop the criticism of others, which comments upon what 'light, moderate, heavy' actually mean. The dictionary says: **Light**: Relatively low in weight, not more than the usual mass **Moderate**: Being within reasonable limits; not excessive or extreme **Heavy**: Of great weight, difficult to lift, of great density and greater than the usual mass.

Edward Allen Eng, El Allen Associates



Collision Deformation Classification: Green Vehicle: CDC - 12FDEW3 = PDOF - 10
White Vehicle: CDC - 01FZEW4 = PDOF + 35

COLLISION DEFORMATION CLASSIFICATION

This is an easy reference chart for field use. Write your codes in wash able pen beside each box and transfer to your report.

Clock direction is principal direction of force.

Example – Rear = 06

Location of Damage

Distributed Side or End = D

Left Front or Rear = L

Centre Front or Rear = C

Right Front or Rear = R

Side Front L/R = F

Side Centre Section L/R = P

Side Rear Left or Right = B

Side or end F+P or L+C = Y

Side or End B+P or R+C = Z

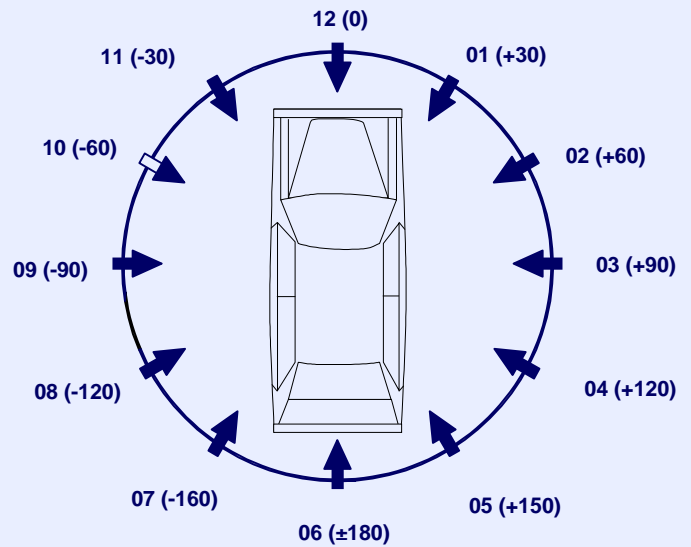

Choose Clock Direction

Deformation Location

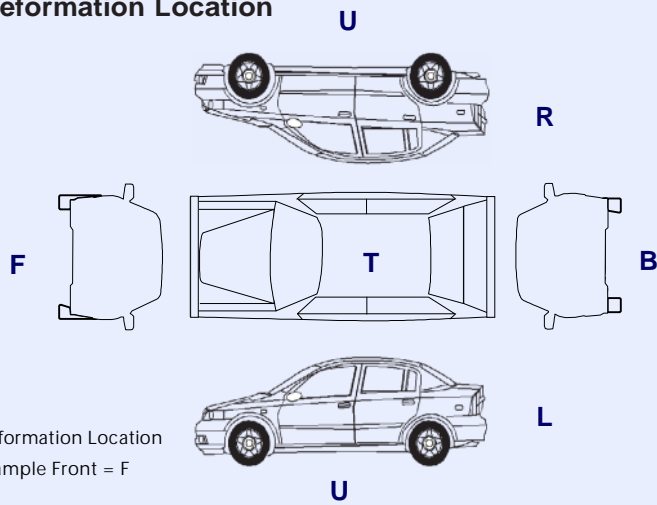

Deformation Location Example Front = F

Location of Damage

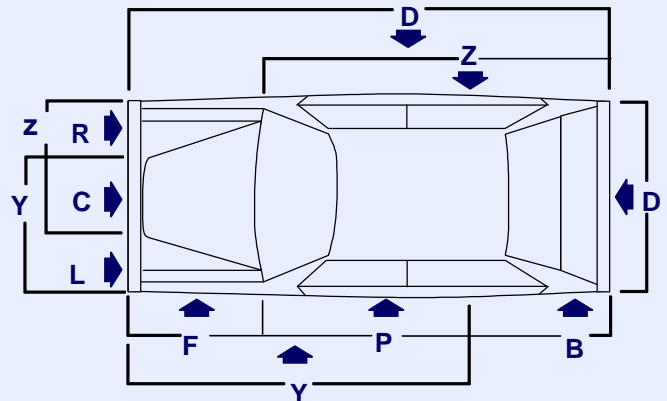

COLUMNS

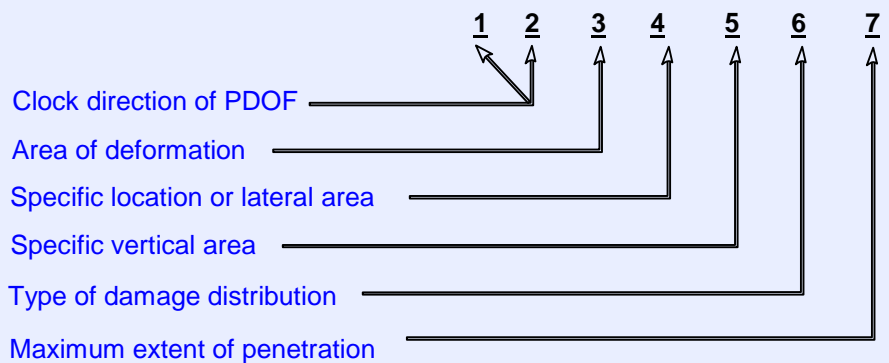

CDC/PDOF 1

CDC/PDOF 2

The Collision Damage Classification (CDC) is a seven character code which describes the vehicle damage. The characters in the CDC identify the Principal Direction Of Force (PDOF) in the clock direction, the impacted surface (front, right, back or left), the shape of the damage profile and the extent of the maximum penetration. If a more accurate direction than the clock direction is known, the PDOF may be entered in degrees after the CDC.

Columns 1 & 2 – Principal Direction of Force

As defined in the first two columns of the CDC, the Principal Direction of Force (PDOF) during impact is the direction of the force that caused the crush and sheet metal displacement on the damaged vehicle.

The PDOF is determined by the vector

result of forces normal and tangential to the surface of the vehicle in the area of deformation.

In columns 1 & 2 of the CDC, the PDOF is designated by hour sectors on a conventional clockface (figure 1 see page 3) and referred to as the clock direction. 12 O'clock indicates a head-on impact, 06 O'clock refers to a rear end impact, 03 and 09 O'clock refer to perpendicular impact to the right and left sides respectively. Angles in between are noted accordingly.



Note the clock direction is a two digit code. That is '06' must be entered not '6'. Note also that by virtue of the hour increments, the clock direction in columns 1 & 2 is rounded to the nearest 30 degrees. The associated PDOF entries are shown below (figure 2)

Figure 1: Columns 1 & 2, Clock Direction of PDOF

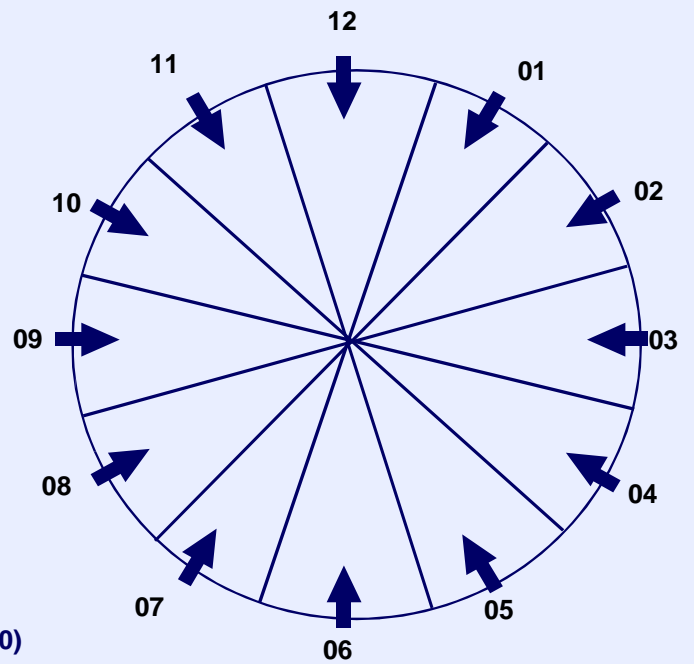

Figure 2: Relationship Between Hour Angles and PDOF (degrees)

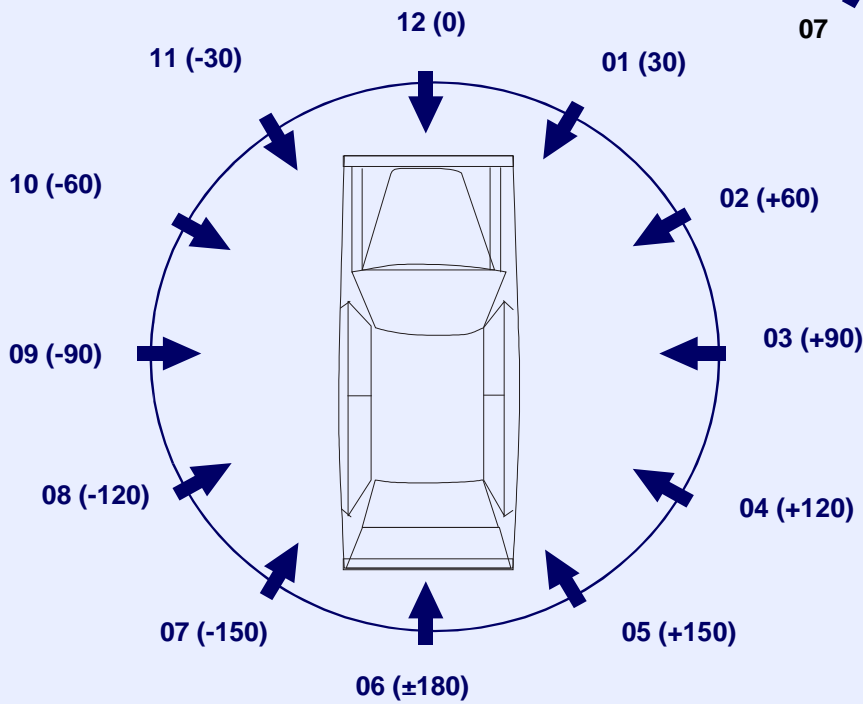
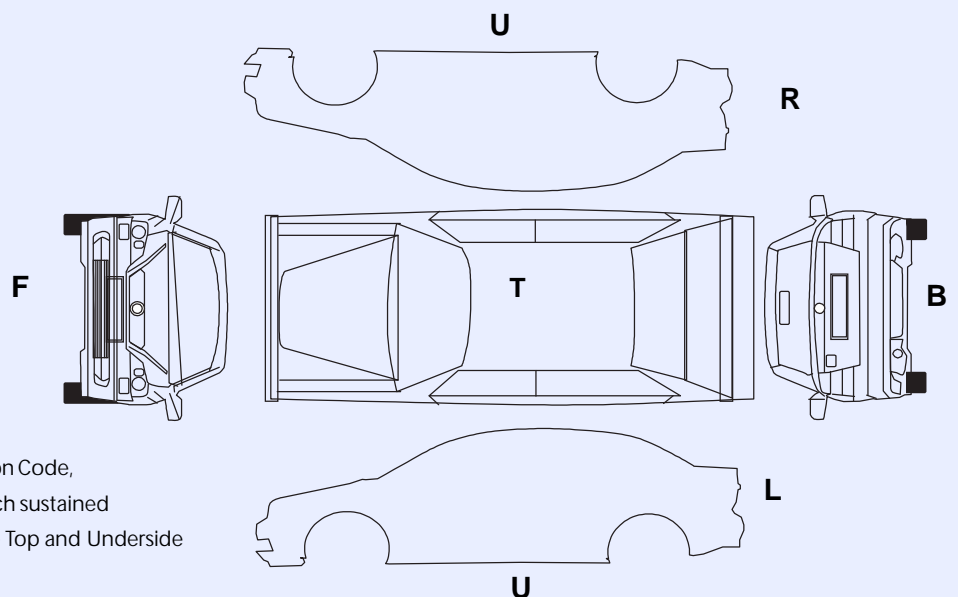

Figure 3: Column 3, Deformation Location Code

Location	Classification
Front	F
Right Side	R
Back (rear)	B
Left Side	L
Top	T
Undercarriage	U
Unclassifiable	X



Column 3 – Deformation Location Code

The third column of the CDC, the Deformation Location Code, specifies the general area (figure 3) of the vehicle which sustained damage—either the Front, Right, Back or Left side. The Top and Underside of the vehicle may also be damaged.

Figure 4: Column 4, Longitude or Lateral Location

Location	Classification
Distributed – side or end	D
Left – front or rear	L
Centre – front or rear	C
Right – front or rear	R
Side Front – left or right	F
Side Centre Section – left or right	P
Side Rear – left or right	B
Side or End – F+P or L+C	Y
Side or End – B+P or R+C	Z

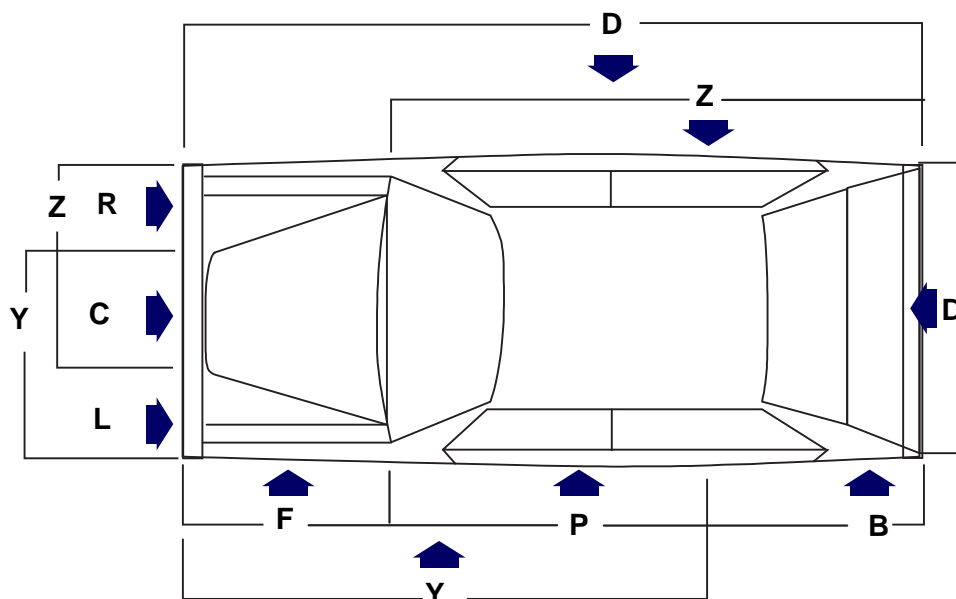

E J ALLEN & ASSOCIATES

Consultant Investigation & Litigation Engineers
Excellence in Engineering

Based in London and the Home Counties E J Allen & Associates undertake **Automobile – Industrial – Forensic – Mechanical** investigations all over the United Kingdom and abroad.

Make us your first call

All our professional Expert Engineers are professionally qualified according to discipline, members of Technical Institutes and registered with the Engineering Council and The Academy of Experts

Our forensic investigations result in fully detailed reports with imagery, diagrams, video and total station computer generated scale plans.

Our reports are CPR 35 and CrPR – part 33 compliant. We are fully conversant with **civil** and **criminal** work.

We are licensed users of **Edcrash, AI Damage, Assessor 2000 and Crash 2000, Glassmatix** and **Evaluator**. All of our test equipment is annually calibrated to BSI and applicable standards.

Phone us today or contact us by e-mail or website to obtain a copy of our brochure and to discuss the services we offer which can be tailored to your requirements



E J Allen & Associates has been established since 1989 and our consultants have over 75 years combined experience.

64 Spring Park Road, Shirley, Croydon, Surrey, CR0 5EL, DX48660 Shirley (Croydon)
Tel: 020 8662 0007 Fax: 020 8662 0066
Email: expert@ejallen.co.uk Website: www.ejallen.co.uk

VEHICLE INSPECTIONS
CAR AND MOTORCYCLE
LCV HGV
CLASSIC AND VINTAGE
HORSE BOXES
MOBILE HOMES CARAVANS
LEISURE CRAFT

PRE PURCHASE AND
DIMINUTION IN VALUE

ROAD TRAFFIC ACCIDENT
RECONSTRUCTION AND
DAMAGE CONTINUITY

LOW AND HIGH SPEED
COLLISION TESTING
AND CALCULATION

FORK LIFT TRUCK &
MECHANICAL HANDLING
EQUIPMENT

SPECIALIST FORENSIC
INVESTIGATIONS
RELATING TO
ENGINEERING MATTERS

ENGINES CAUSES OF FAILURE
LAND BASED & LIGHT MARINE

PEDESTRIAN SLIPPING & TRIPPING
FALLING FROM HEIGHTS
INCLUDING PLATFORMS, LADDERS
AND CHERRY PICKERS

INDUSTRIAL INCIDENTS
INVOLVING PERSONAL
INJURY WHILST WORKING ON
WOODWORKING &
METALWORK MACHINES

PLAYGROUND & FAIRGROUND
PERSONAL INJURY ACCIDENTS

Column 4 – Specific Longitudinal or Lateral Location of Deformation

The specific area of damage (Distributed, Left, Centre, Right etc) can be considered a suffix to column 3 in that the specific Longitudinal or Lateral Location of Deformation (figure 4, page 4) describes in greater detail, the general area of damage (front, right, back or left) entered in column 3. Note in figure 4 that letters shown on the front and rear may be applied to either the front or the rear; letters shown on the sides may be used for either side.

Column 5 – Specific Vertical Location of Deformation

This entry is also a suffix to column 3 and refers to vertical damage characteristics (figure 5). An entry (A, H, E, G, M, L or W) is necessary for a valid CDC.

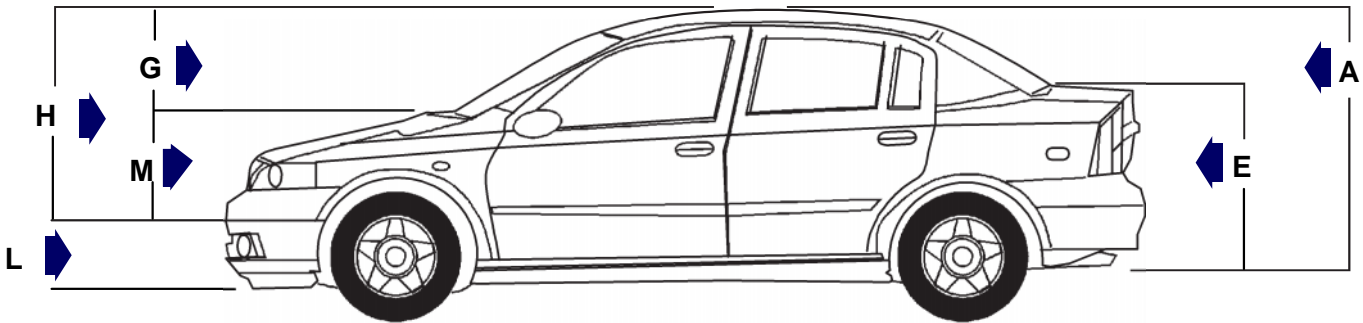

Figure 5: Column 5 Vertical Location

Vertical Location: Front, Rear or Side Impacts	Classification
All	A
Top of Frame to top of Vehicle	H
Everything below Belt Line	E
Belt Line and Above	G
Middle—top of frame to belt line or hood	M
Frame—top of frame, frame	L
Bottom of frame (inc undercarriage)	L
Below undercarriage level (wheels and tyres only)	W



Figure 6—Column 6, Type of Damage Distribution

Type	Classification
Wide impact Area	W
Narrow Impact Area	N
Sidewipe	S
Rollover (includes rolling onto side)	O
Corner (extends from corner to < 16in (410mm)	E
Conversion in impact type	K
Requires multiple CDC	K
No residual Deformation	U



Column 6 – Type of Damage Distribution

The general type of impact or accident is defined in column 6.

Further, some entries violate the assumptions of analysis, notably Sideswipe, Rollover and multiple impact (K). narrow impact is specified, the width of the damage profile is set to 16in (410mm); otherwise Wide impact is assumed and the width of the damage is set based on tabular data in conjunction with the Specific Longitudinal or Lateral Location of Deformation entered in column 4 of the CDC.

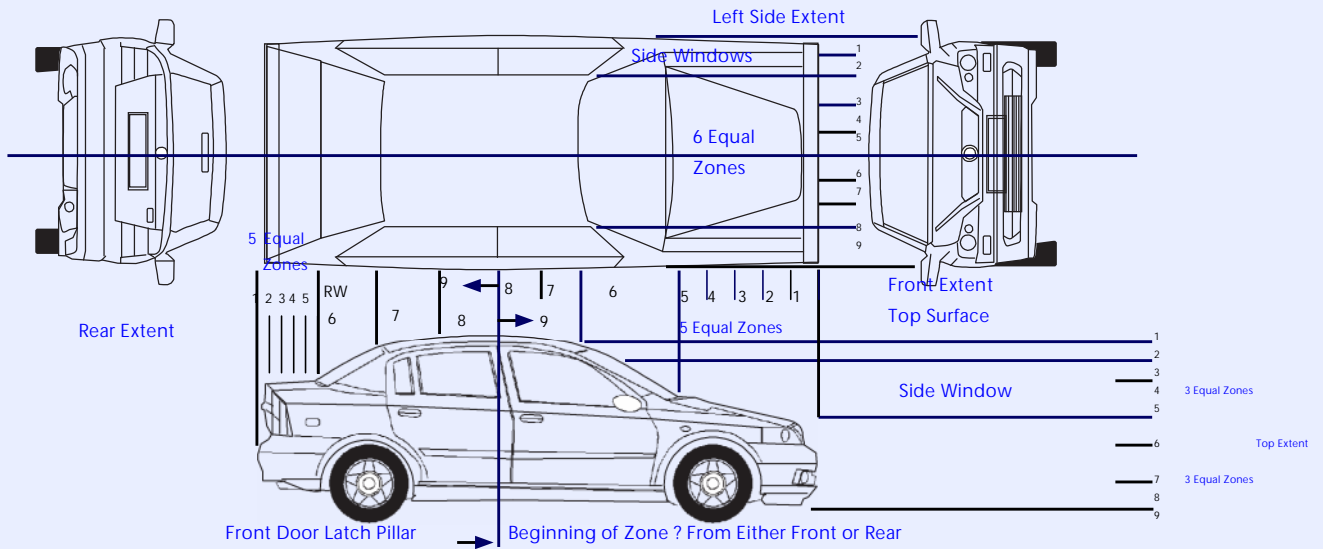

Column 7 – Maximum Extent of Penetration

The extent of maximum residual deformation to the vehicle is based on a somewhat qualitative system wherein the vehicle is divided into penetration zones numbered from 1-9 (figure 7). Along the longitudinal axis of the vehicle, the B-pillar is generally taken as the maximum (ie the beginning of zone 9). A frontal crush penetrating rearward to the B-pillar will have a penetration

extent of 9; conversely, a rear impact penetrating forward to the B-pillar will also have a penetration extent of 9. Laterally, a penetration extent of 9 is associated with penetrating the entire width of the vehicle. A penetration extent of 0 would imply no permanent deformation, and therefore no CDC. For damage extents between 0 and 9, the extents are divided into zones normally having equal width. The exception to this rule occurs in areas which include the windshield and windows, as shown in figure 7.

Note: See 'Collision Deformation Classification' SAE J224 MAR80 [12] for further details

