



Emax EVolution

ULTRA-PRECISION BRUSHLESS MICRO-GRINDER



Electrically Driven
EmaxEVO
ESPERT

Air-Driven
ROTUS
IMPULSE
PRESTO II

General Parts
GENERAL
PARTS

CAUTION

Exclusive Tools
EXCLUSIVE
TOOLS

INDEX

Protective
Equip.

Electrically Driven
EmaxEVO
ESPERT

Air-Driven
ROTUS
IMPULSE
PRESTO II

General Parts
GENERAL
PARTS

CAUTION

Exclusive Tools
EXCLUSIVE
TOOLS

INDEX

Protective
Equip.

ADVANCED HIGH PERFORMANCE BRUSHLESS MICRO-GRINDER

Emax **EVolution Series**

Emax **EVolution SERIES** ◀◀

“Tough Torque”

“Flashing Live Load Indicator”

“No need of changing carbon brushes”
(Brushless motor)



1,000~40,000 min⁻¹

Emax **EVolution Standard Set**

Code No.	8233 (120V)	Model	EV410-120
Code No.	8225 (230V)	Model	EV410-230

*Please check the power source plug type (P.58).

Standard Equipment

- Micro Grinder (IR-310+ENK-410S) : 1 pc.
- Collet ø3.0 mm (CHH-3.0), ø2.35 mm (CHH-2.35) : 1 pc. each
- Controller (NE249) : 1 pc.
- Accessories : Handpiece Holder : 1 pc., Handpiece Stand : 1 pc.
Power Supply Cord : 1 pc., Spanner (7 x 5.1) : 1 pc.
Pin Spanner (K-233) : 2 pcs., L Shaped Spanner (9) : 1 pc.

*Torque set → P.22



Application Examples



Tool : Electroplated Diamond Burs
→ Please see the NAKANISHI "TOOLS" Catalog.



Tool : Diamond Grinding Discs
→ Please see the NAKANISHI "TOOLS" Catalog.



Tool : Flap Wheels
→ Please see the NAKANISHI "TOOLS" Catalog.



Tool : Abrasive Belts → P.72



Tool : Sand Paper Disk → P.69



Tool : Felt Bobs
→ Please see the NAKANISHI "TOOLS" Catalog.

Electrically Driven
EmaxEVO ESPERT
Air Driven
ROTUS IMPULSE PRESTO II
General Parts
GENERAL PARTS
CAUTION
Exclusive Tools
EXCLUSIVE TOOLS
INDEX
Protective Equip.

Electrically Driven
EmaxEVO ESPERT
Air Driven
ROTUS IMPULSE PRESTO II
General Parts
GENERAL PARTS
CAUTION
Exclusive Tools
EXCLUSIVE TOOLS
INDEX
Protective Equip.

ADVANCED HIGH PERFORMANCE CONTROLLER

Emax EVolution Controller

Advanced Control Function

Upgraded Digital Display. EVOLUTION on Speed Control Volume with Flash Load Indicator.



Motor speed digital display

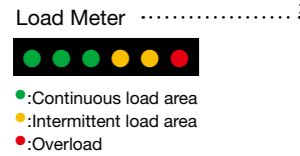

Forward / Reverse Select Switch
Forward/Reverse rotation can be selected.

ø12mm Speed Control Volume
Easy to operate by one finger

Motor A
ON/OFF Function

Emax EVolution Controller

Code No.	8224 (120V)	Model	NE249 120
Code No.	8227 (230V)	Model	NE249 230

Specifications

Description	Emax EVolution Controller
Power Source	AC120/230V, 50-60Hz
Dimensions	W130 x D254 x H97 mm
Weight	2.3 kg

Accessories : Handpiece Holder : 1 pc., Handpiece Stand : 1 pc.
Power Supply Cord : 1 pc.

Memory Speed Function FiXspeed®

An exclusive new feature of the Emax EVolution, the FiXspeed® system allows everyone easily to fix speed of motor A and B independently prior to operate. For example motor A can be set to maintain the speed set by the FiXspeed® system while motor B has variable control using a foot controller. This function brings for unprecedented workability.

Auto Cruise Function

The controller is equipped with an Auto Cruise Function. While using foot controller for work, anyone could fix the motor at any speed by the embedded motor switch. Once speed is set, foot controller is not required. This function eliminates foot fatigue during operation.



Memory Speed Function FiXspeed®

Motor B
ON/OFF Function

⚠ Never connect to E-max Series motor.
*Please check the power source plug type (P.58).

Diversity for work efficiency

2 Motors of A and B can be connected, and select the suited motor for work situation. (Simultaneous motor operation is not allowable)



Advanced User Friendly Design

New Industrial Design. EVOLUTION from Tower-type solid E-Max to User-oriented Identity. Design meets Performance.



ADVANCED HIGH PERFORMANCE BRUSHLESS MOTOR

Emax EVolution Motor

Excellent Durability



- High performance brushless motor eliminates the need of changing carbon brushes.
- RPM variation is minimal even when load changes. Allowing difficult and stable cutting in stress free motion. Suitable performance for finish grinding.
- Provides superior quietness and smoothness from low speed to high speed.

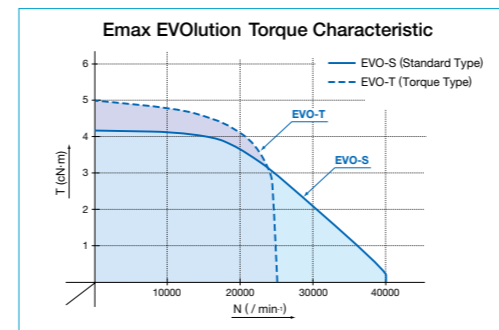

2 Types of Motors

Provides choice of various applications.

- Standard Type Motor 1,000~40,000 min⁻¹ (ENK-410S) **Blue**
- Torque Type Motor 1,000~25,000 min⁻¹ (ENK-250T) **Green**

*Exclusive use for Emax EVolution

NAKANISHI Smart Switch

The switch provides a click sensation. A confirmation tone is reacted by the controller when the switch is operated. The motor type is distinguishable by the switch color.



Standard Type Motor

Code No.	8086
Model	ENK-410S

1,000~40,000 min⁻¹

• Excellent combination of high speed, lightweight, small diameter and high torque. This lightweight and compact general-use type is perfect for precision work.

- ◆ Max. Power : 73W
- ◆ Max. Torque : 4.3 cN·m
- ◆ With Straight Cord : 1.5 m
- ◆ Weight : 90 g (w/o cord)

Standard Accessories
• Pin Spanner (K-233) : 1 pc.

⚠ Never connect to E-max Series controller.



Torque Type Motor

Code No.	8087
Model	ENK-250T

1,000~25,000 min⁻¹

• Combines the best of both high speed and high torque. It is perfect for applications requiring large burs.

- ◆ Max. Power : 76 W
- ◆ Max. Torque : 4.8 cN·m
- ◆ With Straight Cord : 1.5 m
- ◆ Weight : 147 g (w/o cord)

⚠ Never connect to E-max Series controller.



Code No.	Model
----------	-------

Attachment

*Interchangeable with attachments form the E-max and ROTUS system.

1147 IR-310 (P.13)



Ring Type

1005 IH-300 (P.21)



Lever Type

2811 IG-400 (P.21)



Straight Type

1016 HG-200 (P.21)



6 mm Torque Type*

1017 BMH-300 (P.14)



Long Type

1012 MFC-300S (P.15)



90° Mini Angle Type

1013 MFC-300M (P.15)



90° Mini Angle Type (Very Small Head)

1006 IC-300 (P.16)



90° Angle Type

1014 KC-300 (P.16)



50° Angle Type

LUSTER
1302 LS-100 (P.21)



Pistol-Type Polisher (Reciprocating motion)

MINI-LUSTER
1307 ML-8 (P.17)



Pencil-Type Reciprocating Polishing Finisher (Reciprocating motion)

SWING-LUSTER
1380 SLS-16 (P.18)



Pencil-Type Reciprocating Polishing Finisher (Right to Left motion)

Hammer Action Type
8060 HA-500 (P.21)



Engraving and Ornament Processing Work Hammer

FINE BELT SANDER
1146 KBS-101 (P.19)



Small-sized Handy Belt Sander



LUSTER
1483 NLS-110 (P.20)

Exclusive use for Emax EVOLution

- Wide selection of attachments available depending on the application.

Speed Reducer · Extension Joint



Extension Joint
1015 CN-01 (P.22)



1/4 Speed Reducer
1009 RG-01 (P.22)



1/15 Speed Reducer
1010 RG-02 (P.22)

- May be connected between the motor and the attachment when required increased torque.

Motor

Emax EVOLution Series



• Standard Type Motor with Cord (P.10)
8086 ENK-410S 1,000-40,000 min⁻¹



• Torque Type Motor with Cord (P.10)
8087 ENK-250T 1,000-25,000 min⁻¹

Exclusive use for Emax EVOLution

ROTUS Series



• Air Motor with Hose 360° Twist-Free Joint Mechanism (P.40)
1004 IM-301 3,000-30,000 min⁻¹

Controller

Emax EVOLution



8224 (120V) NE249 120
8227 (230V) NE249 230 (P.9)

• Foot Controller



8106 FC-64 (P.22)

Sets



Emax EVOLution Standard Set

Code No.	Model
8233 (120V)	EV410-120
8225 (230V)	EV410-230

Standard Equipment

- Micro Grinder (IR-310+ENK-410S) : 1 pc.
- Collet ø3.0 mm (CHH-3.0), ø2.35 mm (CHH-2.35) : 1 pc. each
- Controller (NE249) : 1 pc.
- Accessories : Handpiece Holder : 1 pc. Handpiece Stand : 1 pc. Power Supply Cord : 1 pc. Spanner (7 x 5.1) : 1 pc. Pin Spanner (K-233) : 2 pcs. L Shaped Spanner (9) : 1 pc.

Electrically Driven

Air Driven

⚠ Details of Maximum Allowable speed on intermittent use or continuous use P.13-22

<Caution>
* 1 : Use 6 mm Torque Type HG-200 to connect ENK-250T

* This air line kit is designed for use with the AFC-45 foot controller, Code No.1064.



ROTUS Standard Set

Code No.	Model
1163	ROTUS-IR

Standard Equipment

- Air Grinder (IR-310+IM-301) : 1 pc.
- Collet ø3.0mm (CHH-3.0), ø2.35 mm (CHH-2.35) : 1 pc. each
- Air Line Kit (AL-H1207F) : 1 pc.
- Foot Controller (AFC-45) : 1 pc.
- Accessories : Piping Hose 2m (K-275) : 1 pc. Lubricating Oil (K-211) : 1 pc. Spanner (7x5.1) : 1 pc. Pin Spanner (K-233) : 2 pcs. L Shaped Spanner (9) : 1 pc.

Electrically Driven

EmaxEVO ESPERT

Air Driven

ROTUS IMPULSE PRESTO II

General Parts

GENERAL PARTS

CAUTION

Exclusive Tools

EXCLUSIVE TOOLS

INDEX

Protective Equip.

Electrically Driven

EmaxEVO ESPERT

Air Driven

ROTUS IMPULSE PRESTO II

General Parts

GENERAL PARTS

CAUTION

Exclusive Tools

EXCLUSIVE TOOLS

INDEX

Protective Equip.

RING TYPE MICRO-GRINDER ◀◀

PRECISION MICRO-GRINDER

Ring Type Attachment

Ring Type Chucking System

- One-touch ring type bur replacement.
- High precision and high reliability is realized by micron precision.
- Slim, lightweight design allows for fine finishing of delicate parts.



40,000 min⁻¹ Max.

◆ Weight : 92 g

Standard Size Collet

ø3.0 mm (CHH-3.0) ø2.35 mm (CHH-2.35)

Optional Collets : CHH group are shown in page (P.55)

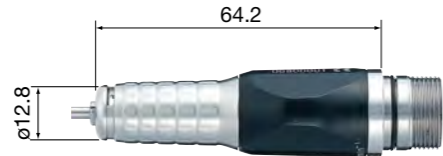

Code No. **1147** Model **IR-310**

Standard Accessories

- Spanner (7x5.1) : 1 pc.
- Pin Spanner (K-233) : 1 pc.
- L Shaped Spanner (9) : 1 pc.

Ring Type Attachment + Standard Type Motor Combination Example

1,000~40,000 min⁻¹

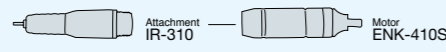

Ring Type Attachment + Torque Type Motor Combination Example

1,000~25,000 min⁻¹

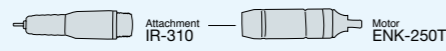

Emax EVolution Controller (P.9)
 <Code No. : 8224 (120V) · Model : NE249 120>
 <Code No. : 8227 (230V) · Model : NE249 230>

Combination Example	d	D	L1	L2	L3	Weight	Max. Torque	Speed Range	Collet
1147+8086	ø12.8	ø24.5	64.2	97	161.2	182 g (*)	4.3 cN·m	1,000~40,000 min ⁻¹	ø0.3~ø3.175 mm CHH Group (P.55)
1147+8087	ø12.8	ø28.4	64.2	108	172.2	239 g (*)	4.8 cN·m	1,000~25,000 min ⁻¹	ø0.3~ø3.175 mm CHH Group (P.55)

* Weight (w/o Straight Cord)

LONG TYPE MICRO-GRINDER ◀◀

PRECISION MICRO-GRINDER

Long Type Attachment

Tip diameter ø13 mm

- This unique slim body makes it ideal for cutting and grinding the bottom surface of deep ribs or holes.
- Collet is tightened by a spanner.
- The tip diameter of attachment is ø13 mm.



35,000 min⁻¹ Max.

◆ Weight : 156 g

Standard Size Collet

ø3.0 mm (CHM-3.0)

Optional Collets : CHM group are shown in page (P.56)

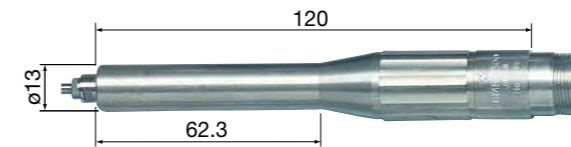

Code No. **1017** Model **BMH-300**

Standard Accessories

- Spanner (7 x 5.1), (6 x 4.5) : 1 pc. each
- Pin Spanner (K-233) : 1 pc.

Long Type Attachment + Standard Type Motor Combination Example

1,000~35,000 min⁻¹



Emax EVolution Controller (P.9)
 <Code No. : 8224 (120V) · Model : NE249 120>
 <Code No. : 8227 (230V) · Model : NE249 230>

Combination Example	Outside Diameter	Weight	Max. Torque	Speed Range	Collet
1017+8086	Refer to the dimensions	246 g (*)	4.3 cN·m	1,000~35,000 min ⁻¹	ø0.3~ø3.175 mm CHM Group (P.56)

* Weight (w/o Straight Cord)

Electrically Driven

EmaxEVO ESPERT

Air Driven

ROTUS IMPULSE PRESTO II

General Parts

GENERAL PARTS

CAUTION

Exclusive Tools

EXCLUSIVE TOOLS

INDEX

Protective Equip.

Electrically Driven

EmaxEVO ESPERT

Air Driven

ROTUS IMPULSE PRESTO II

General Parts

GENERAL PARTS

CAUTION

Exclusive Tools

EXCLUSIVE TOOLS

INDEX

Protective Equip.

MINI ANGLE TYPE MICRO-GRINDER ◀◀

ANGLE TYPE GRINDER

Mini Angle Type Attachment



For Chamfering Deep Hole | Bur Only $\phi 1.6$ mm | Exclusive Tools P.71

- Suitable for chamfering and deburring the inside of the slit pipe.
- The world's smallest angle type attachment.
- Various $\phi 1.6$ mm exclusive tools are also available.

15,000 min⁻¹ Max.
 ◆ Minimum Inner Diameter : $\phi 13$ mm
 ◆ Holding tool width : 7.2 mm ◆ Weight : 47 g
 ◆ Speed Reduction Ratio : 10/11

Standard Size Collet | Exclusive Tools P.71
 $\phi 1.6$ mm (K-253) P.56

◆ Minimum Inner Diameter : $\phi 20$ mm
 ◆ Holding tool width : 11.9 mm ◆ Weight : 50 g
 ◆ Speed Reduction Ratio : 10/11

Standard Size Collet | Exclusive Tools P.71
 $\phi 1.6$ mm (K-252) P.56

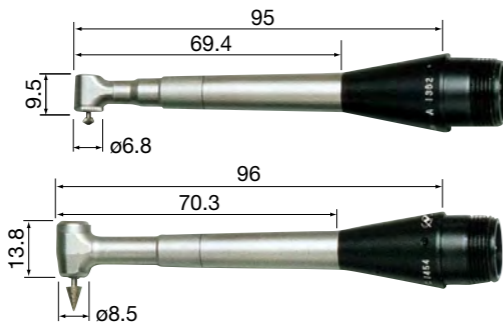

Mini Angle Type (Very Small Head)
 Code No. **1013** Model **MFC-300M**

Standard Accessories
 • Chuck Wrench (K-232) : 1 pc. • Pin Spanner (K-233) : 1 pc.

Mini Angle Type
 Code No. **1012** Model **MFC-300S**

Standard Accessories
 • Chuck Wrench (K-232) : 1 pc. • Pin Spanner (K-233) : 1 pc.

Mini Angle Type Attachment + Standard Type Motor Combination Example

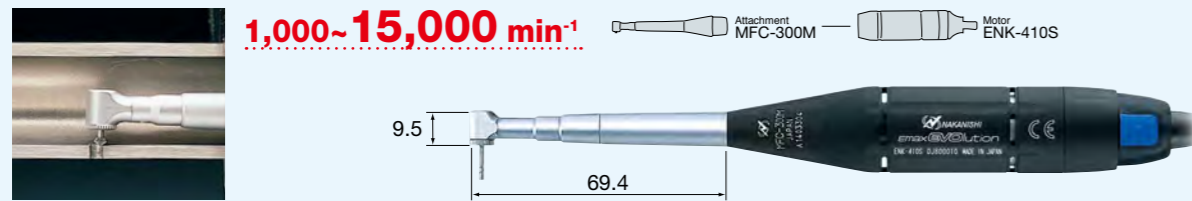

Mini Angle Type Attachment + Standard Type Motor Combination Example

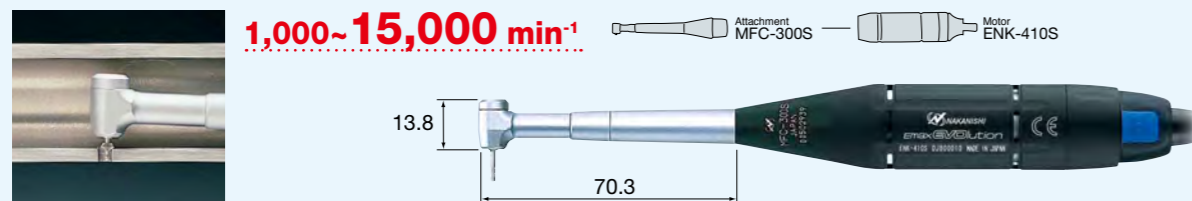

Emax EVolution Controller (P.9)
 <Code No. : 8224 (120V) · Model : NE249 120>
 <Code No. : 8227 (230V) · Model : NE249 230>

⚠ Never connect to E-max Series Controller.

Combination Example	d	D	L1	L2	L3	Weight	Max. Torque	Speed Range	Collet
1013+8086	$\phi 6.8$	$\phi 24.5$	95	97	192	137 g (*)	4.3 cN·m	1,000~15,000 min ⁻¹	$\phi 1.6$ mm (K-253) (P.56)
1012+8086	$\phi 8.5$	$\phi 24.5$	96	97	193	140 g (*)	4.3 cN·m	1,000~15,000 min ⁻¹	$\phi 1.6$ mm (K-252) (P.56)

* Weight (w/o Straight Cord)

TOOL : $\phi 1.6$ mm Please see the NAKANISHI "TOOLS" Catalog.

ANGLE TYPE MICRO-GRINDER ◀◀

ANGLE TYPE GRINDER

Angle Type Attachment



Most suitable for polishing flat surfaces at speed | Exclusive Tools P.69-71

- Suitable for polishing a flat surface at speed with a grinding disk pad.
- Perfect for finishing bottom surfaces and other tight, hard to reach areas.

30,000 min⁻¹ Max.
 ◆ Weight : 45 g
 ◆ Speed Reduction Ratio : 3/4
 Standard Size Collet | Exclusive Tools P.69-71
 $\phi 3.0$ mm (CHC-3.0)
 Optional Collets : CHC group are shown in page (P.55)

◆ Weight : 45 g
 ◆ Speed Reduction Ratio : 3/4
 Use the motor in reverse rotation for clockwise rotation.
 Standard Size Collet | Exclusive Tools P.69-71
 $\phi 3.0$ mm (CHC-3.0)
 Optional Collets : CHC group are shown in page (P.55)

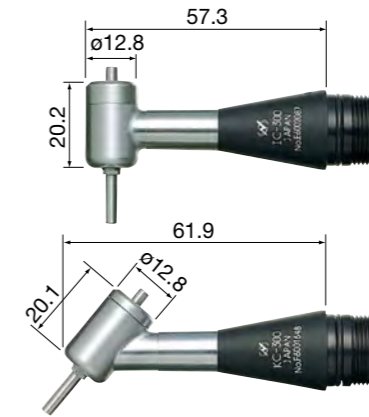

Angle Type (90°)
 Code No. **1006** Model **IC-300**

Standard Accessories
 • Chuck Wrench (K-231) : 1 pc. • Pin Spanner (K-233) : 1 pc.
 • Standard Accessories : 1 set

Angle Type (50°)
 Code No. **1014** Model **KC-300**

Standard Accessories
 • Chuck Wrench (K-231) : 1 pc. • Pin Spanner (K-233) : 1 pc.
 • Standard Accessories : 1 set

90° Angle Type Attachment + Standard Type Motor Combination Example

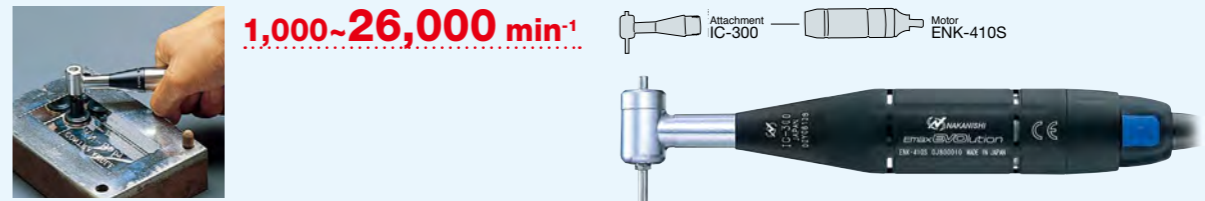

50° Angle Type Attachment + Standard Type Motor Combination Example

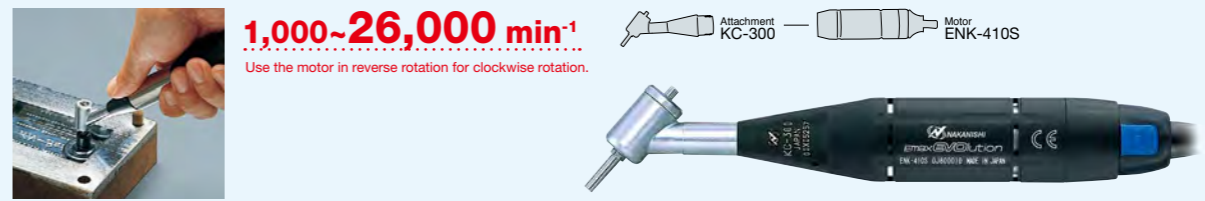

Emax EVolution Controller (P.9)
 <Code No. : 8224 (120V) · Model : NE249 120>
 <Code No. : 8227 (230V) · Model : NE249 230>

⚠ Never connect to E-max Series Controller.

Combination Example	d	D	L1	L2	L3	Weight	Max. Torque	Speed Range	Collet
1006+8086	20.2	$\phi 24.5$	57.3	97	154.3	135 g (*)	4.3 cN·m	1,000~26,000 min ⁻¹	$\phi 1.0\sim\phi 3.175$ mm
1014+8086	20.1	$\phi 24.5$	61.9	97	158.9	135 g (*)	4.3 cN·m	1,000~26,000 min ⁻¹	CHC Group (P.55)

* Weight (w/o Straight Cord)

Code No.	Description	Package	Code No.	Description	Package
64101	Rubber Pad (Small) O.D. $\phi 10$ mm	1 pc./pack	64153	Sand Paper Disk for med. pad $\phi 21$ #180	5 pcs./pack
64102	Rubber Pad (Med) O.D. $\phi 20$ mm		64157	Sand Paper Disk for med. pad $\phi 21$ #600	
64103	Rubber Pad (Large) O.D. $\phi 30$ mm		64173	Sand Paper Disk for large pad $\phi 31$ #180	
64133	Sand Paper Disk for small pad $\phi 11$ #180	64177	Sand Paper Disk for large pad $\phi 31$ #600		
64137	Sand Paper Disk for small pad $\phi 11$ #600	5 pcs./pack			

• Exclusive tools for Angle Type Attachment P.69~71

Electrically Driven

EmaxEVO ESPERT

Air Driven

ROTUS IMPULSE PRESTO II

General Parts

GENERAL PARTS

CAUTION

Exclusive Tools

EXCLUSIVE TOOLS

INDEX

Protective Equip.

Electrically Driven

EmaxEVO ESPERT

Air Driven

ROTUS IMPULSE PRESTO II

General Parts

GENERAL PARTS

CAUTION

Exclusive Tools

EXCLUSIVE TOOLS

INDEX

Protective Equip.

MINI-LUSTER ◀◀

PENCIL-TYPE RECIPROCATING POLISHING FINISHER

MINI-LUSTER Attachment

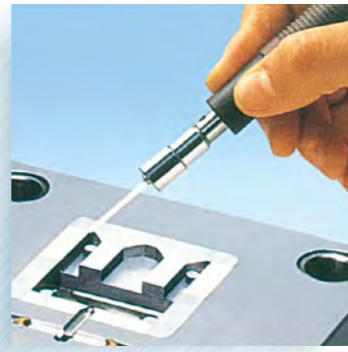

Stroke Range 0.8 mm Reciprocating Motion Exclusive Tools P.67 ~ 69

- Due to pencil type grip, it is most suitable for polishing narrow grooves, details, etc.
- Lightweight, compact design and minimal vibration keep the hand free from fatigue for long continuous operation.
- By using the grindstone holder provided, various tools such as oil stone, super stone, diamond files, etc. can be used.

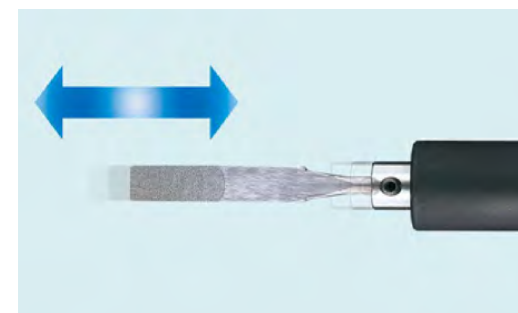

25,000 min⁻¹ Max.
 ◆ Stroke Range (Fixed) : 0.8 mm
 ◆ Reciprocating Stroke (Variable) : 0~6,380 times/min.
 ◆ Weight : 130 g
 ◆ Max. tool shank diameter ø3.2 mm, Screw clamp type

Exclusive Tools P.67 ~ 69

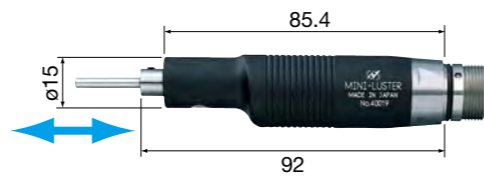

Code No. **1307** Model **ML-8** Stroke (0.8 mm)

Standard Accessories
 • Allen Wrench (1.5 mm) : 1 pc.
 • Standard Accessories : 1 set

SWING-LUSTER ◀◀

PENCIL-TYPE RECIPROCATING POLISHING FINISHER

SWING-LUSTER Attachment



Stroke Range 0~1.6 mm Right to Left Motion Exclusive Tools P.67 ~ 69

- High speed grinding and polishing operations can be performed while maintaining the fine and delicate feeling of hand polishing.
- Lightweight pencil type design makes it easy to work in tight areas.
- Ergonomically designed to provide high sensitivity for precision work.
- Easily adjustable stroke length allows efficient work on minute areas of large sections.

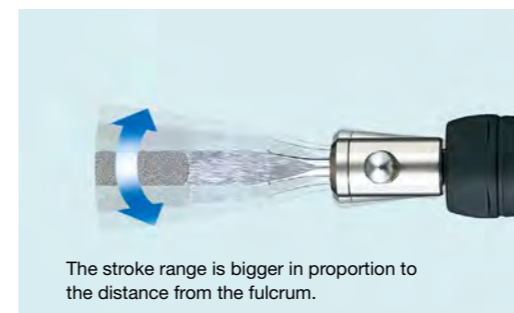

30,000 min⁻¹ Max.
 ◆ Reciprocating Stroke (variable) : 0~7,650 times/min.
 ◆ Stroke Range (variable) : 0.6 mm
 ◆ Weight : 127 g
 ◆ Max. tool shank diameter ø5.0 mm, Screw clamp type.

Exclusive Tools P.67 ~ 69



Code No. **1380** Model **SLS-16**

Standard Accessories
 • Spanner (16 x 18), (20 x 24) : 1 pc. each
 • Allen Wrench (1.5 mm) : 1 pc.
 • Standard Accessories : 1 set

MINI-LUSTER Attachment + Standard Type Motor Combination Example

Reciprocating Stroke
0~6,380 times/min.

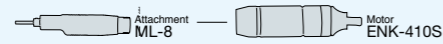

SWING-LUSTER Attachment + Standard Type Motor Combination Example

Reciprocating Stroke
0~7,650 times/min.

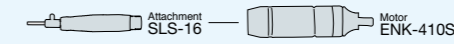



Emax EVolution Controller (P.9)
 <Code No. : 8224 (120V) · Model : NE249 120>
 <Code No. : 8227 (230V) · Model : NE249 230>

⚠ Never connect to E-max Series Controller.



Combination Example	Outside Diameter	Weight	Max. Torque	Reciprocating Stroke	Max. Tool Shank
1307+8086	Refer to the dimensions	220 g (*)	4.3 cN·m	0~9,000 times/min.	ø3.2 mm (screw clamp type)

Standard Accessories

Code No.	Description	Package
62751	Spring Holder	1 pc. each
62510	Ceramic Fiber Grindstone Holder	
62814	Electroplated Diamond File 1.2 x 4 x 50 #100	
60737	Ceramic Fiber Grindstone 1 x 6 x 50 #1200	

• Exclusive tools P.67~69



Emax EVolution Controller (P.9)
 <Code No. : 8224 (120V) · Model : NE249 120>
 <Code No. : 8227 (230V) · Model : NE249 230>

⚠ Never connect to E-max Series Controller.



Combination Example	Outside Diameter	Weight	Max. Torque	Reciprocating Stroke	Max. Tool Shank
1380+8086	Refer to the dimensions	217 g (*)	4.3 cN·m	0~9,000 times/min.	ø5.0 mm (screw clamp type)

Standard Accessories

Code No.	Description	Package
60737	Ceramic Fiber Grindstone 1 x 6 x 50 #1200	1 pc. each
62814	Electroplated Diamond File 1.2 x 4 x 50 #100	
62510	Ceramic Fiber Grindstone Holder	

• Exclusive tools P.67~69

FINE BELT SANDER ◀◀

SMALL-SIZED HANDY BELT SANDER

FINE BELT SANDER Attachment



Exclusive Tools P.72 ~ 73

- Very high belt speed, ideal for applications from deburring to finishing.
- Belt runs Approx. 0~825 m/min.
- Lightweight, compact, minimal vibration and a small diameter grip design keep the hand free from fatigue for long, continuous operation.
- The angle of the belt section is fully adjustable.
- Exchanging the belt is simply done by lever release.
- 4, 6, 8 mm width belts are available.



30,000 min⁻¹ Max.
 ◆ Belt Speed : 0-825 m/min.
 ◆ Weight : 350 g ◆ Belt Sizes : 4, 6, 8 mm Wide x 300mm long
 Exclusive Tools P.72 ~ 73

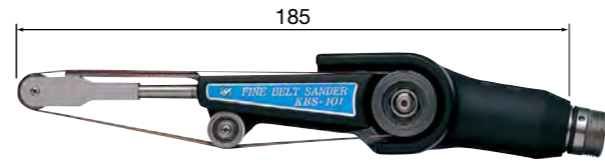

Code No. **1146** Model **KBS-101**

Standard Accessories
 • Allen Wrench (3 mm) : 1 pc. • Standard Accessories : 1 set

FINE BELT SANDER Attachment + Standard Type Motor Combination Example

0~825 m/min.

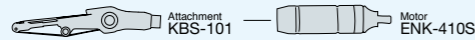

Emax EVolution Controller (P.9)
 <Code No. : 8224 (120V) · Model : NE249 120>
 <Code No. : 8227 (230V) · Model : NE249 230>

⚠ Never connect to E-max Series Controller.

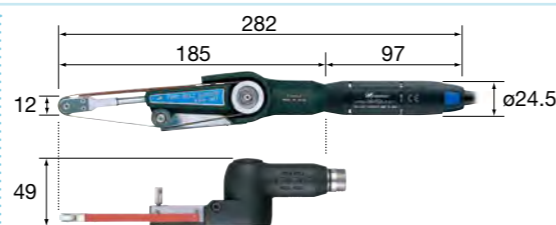

Combination Example	Outside Diameter	Weight	Max. Torque	Belt Speed	Belt Width
1146+8086	Refer to the dimensions	440 g (*)	4.3 cN·m	0~825 m/min.	4 mm, 6 mm, 8 mm

* Weight (w/o Straight Cord)

Code No.	Description	Package
64902	Abrasive Belt Width 4mm #120	2 pcs. each
64904	Abrasive Belt Width 4mm #240	
64906	Abrasive Belt Width 4mm #400	
64912	Abrasive Belt Width 6mm #120	
64914	Abrasive Belt Width 6mm #240	
64916	Abrasive Belt Width 6mm #400	
64922	Abrasive Belt Width 8mm #120	2 pcs. each
64924	Abrasive Belt Width 8mm #240	
64926	Abrasive Belt Width 8mm #400	

Spare Parts

Product	Description	Code No.	Model
	Tension Pulley	1103	TP-12A
	Tension Pulley Assembly	1104	TPA-12A

LUSTER ◀◀

PISTOL-TYPE RECIPROCATING POLISHING FINISHER

LUSTER Emax EVolution

With Motor ON/OFF Switch Reciprocating Motion Exclusive Tools P.67 ~ 69

- Powerful reciprocating stroke polisher equipped with 1/4 Speed Reducer to multiply the torque by 4 times.
- Reciprocating speed and stroke can be easily and continuously controlled.
- LUSTER NLS has a built-in motor. Insert the cord plug into the controller.



LUSTER Emax EVolution

Reciprocating Stroke
 0~6,300 times/min.

Code No. **1483**
 Model **NLS-110**



Stroke Range : 0~6 mm adjustable by allen wrench.

The grinding surface can be set at any angle between 0 and 360° enabling grinding of bottom, right, left and top surfaces without moving the machine itself.
 Mountable tool : Screw clamp type. Max. Tool Shank ø6.4 mm

Designed with comfortable rubber-grip. Well balanced, rubber-grip absorbs vibration from reciprocating strokes reducing fatigue and allowing long, continuous operation.

With Motor ON/OFF Switch

25,000 min⁻¹ Max.
 Specifications
 Stroke Range : 0~6 mm (variable)
 Reciprocating Stroke : 0~6,300 times/min. (variable)
 Max. Torque : 17.2 cN·m
 Weight : 800 g (w/o cord)
 With Straight Cord : 1.5 m

Standard Accessories
 • Allen Wrench (2 mm), (3 mm) : 1 pc. each
 • Lubricating Oil
 • Lubrication Nozzle for LUSTER
 • Standard Accessories : 1 set
 Exclusive Tools P.67 ~ 69



Emax EVolution Controller (P.9)
 <Code No. : 8224 (120V) · Model : NE249 120>
 <Code No. : 8227 (230V) · Model : NE249 230>

⚠ Never connect to E-max Series Controller.

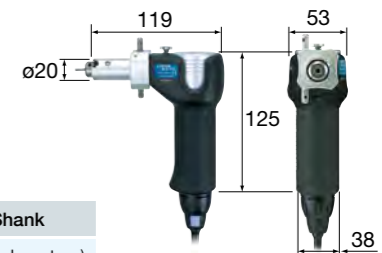

Code No.	Outside Diameter	Weight	Max. Torque	Reciprocating Stroke	Max. Tool Shank
1483	Refer to the dimensions	800 g (*)	17.2 cN·m	0~7,600 times/min.	ø6.4 mm (screw clamp type)

* Weight (w/o Straight Cord)

Code No.	Description	Package
62502	Stone Holder	1 pc./pack
62505	Stone Holder	
62751	Spring Holder	
62525	Rectangular Pad	
62526	Rod for Rectangular Pad	

Code No.	Description	Package
62527	Angle Rod	1 pc./pack
62552	Sand Paper Tip #120	10 pcs./pack
62555	Sand Paper Tip #320	
62557	Sand Paper Tip #600	
62559	Sand Paper Tip #1000	

• Exclusive tools for LUSTER P.67~69

Lever Type Attachment

Code No. **1005** Model **IH-300**

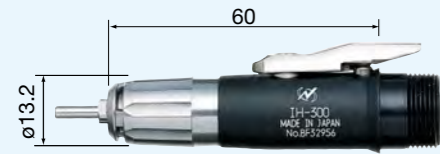

40,000 min⁻¹ Max.

- High precision and high reliability is realized by micron precision.
- Slim, lightweight design allows for fine finishing of delicate parts.
- Lever Type one touch bur release.



◆ Weight : 62 g
 Standard Size Collet
 ø3.0 mm (CHH-3.0) ø2.35 mm (CHH-2.35)
 Optional Collets : CHH group are shown in page (P.55)
 Standard Accessories
 • Spanner (7x5.1) : 1 pc. • Pin Spanner (K-233) : 1 pc.

6 mm Torque Type Attachment

Code No. **1016** Model **HG-200**

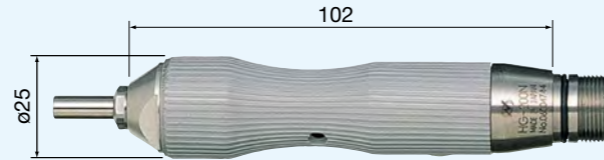

Use HG-200 to connect ENK-250T.

30,000 min⁻¹ Max.

- Permits the use of ø6.0 mm shank burs.
- The resistance produced by cutting and grinding is absorbed by a special rubber grip to eliminate slipping.
- Collet is tightened by a spanner.



◆ Weight : 210 g
 Standard Size Collet
 ø6.0 mm (CHG-6.0)
 Optional Collets : CHG group are shown in page (P.55)
 Standard Accessories
 • Spanner (10 x 10) : 1 pc. • Bar Wrench (K-212) : 1 pc.
 • Pin Spanner (K-233) : 1 pc.

Straight Type Attachment

Code No. **2811** Model **IG-400**

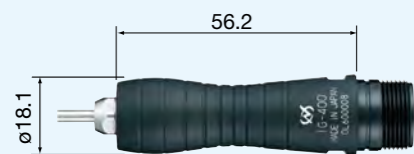

40,000 min⁻¹ Max.

- Lightweight ergonomically designed with minimal vibration for extended use.
- NK Micron Collet permits strong retention and high precision performance.



◆ Weight : 55 g
 Standard Size Collet
 ø3.0 mm (NKM6-3.0)
 Optional Collets : NKM6 group are shown in page (P.56)
 Standard Accessories
 • Collet Nut (CHN-6) • Bar Wrench (PCR-30) : 1 pc.
 • Spanner (9 x 9), (15 x 17) : 1 pc. each

LUSTER Attachment (Pistol-Type Polisher)

Code No. **1302** Model **LS-100**

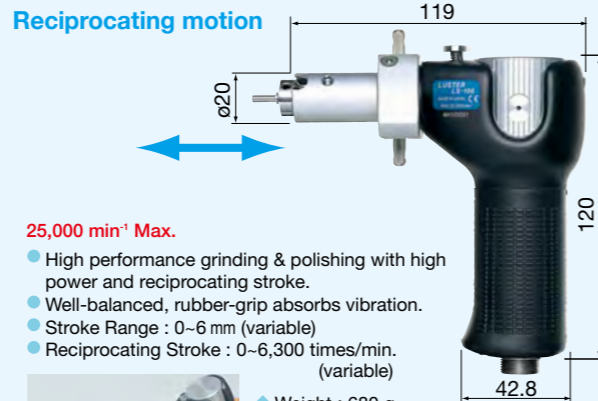

Reciprocating motion

25,000 min⁻¹ Max.

- High performance grinding & polishing with high power and reciprocating stroke.
- Well-balanced, rubber-grip absorbs vibration.
- Stroke Range : 0-6 mm (variable)
- Reciprocating Stroke : 0-6,300 times/min. (variable)



◆ Weight : 680 g
 ◆ Max. tool shank diameter ø6.4 mm, Screw clamp type
 Standard Accessories
 • Allen Wrench (2 mm), (3 mm) : 1 pc. each
 • Lubricating Oil • Lubrication Nozzle for LUSTER
 • Standard Accessories : 1 set

Exclusive Tools P.67 ~ 69

Code No.	Description	Package
62502	Stone Holder	1 pc./pack
62505	Stone Holder	
62751	Spring Holder	
62525	Rectangular Pad	
62526	Rod for Rectangular Pad	
62527	Angle Rod	10 pcs./pack
62552	Sand Paper Tip #120	
62555	Sand Paper Tip #320	
62557	Sand Paper Tip #600	
62559	Sand Paper Tip #1000	

Hammer Attachment

Code No. **8060** Model **HA-500**

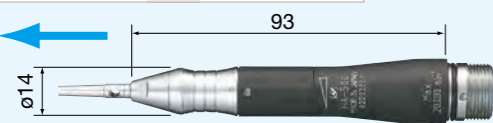

16,000 min⁻¹ Max.

- A wide variety of patterns can be produced by varying the spring pressure and hammer speed.
- Light weight, pencil type grip makes the handpiece very comfortable to hold and easy to use.
- Adjustable spring pressure. ◆ Weight : 95 g
- Self lubricating hammer mechanism ensure excellent durability.
- Stroke Range : 0.4mm ◆ Stroke Times : 25-4,000 times/min. Stroke
- Spring Pressure : 4.4-7.1 N (Ring Adjustment Type)

Standard Accessories
 • Spanner (7 x 5.5) : 1 pc. • Bar Wrench (K-212) : 1 pc.
 • Oil and Oil offer machine • Hammer Bit (For replacement) : 2 pcs.

Hammer Bit to be machined to required shapes (SUS-420, heat treated, approx. HRC50)



Code No.	Package
65301	3 pcs./pack

1/4 Speed Reducer

Code No. **1009** Model **RG-01**

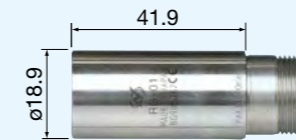

30,000 min⁻¹ Max.

- Mounted between an attachment and a motor.
- The speed is reduced to 1/4 but the torque is multiplied by 4 times.
- Suitable for high torque grinding process or drilling.

◆ Weight : 68 g

Standard Accessories
 • Pin Spanner (K-233) : 1 pc.

1/15 Speed Reducer

Code No. **1010** Model **RG-02**

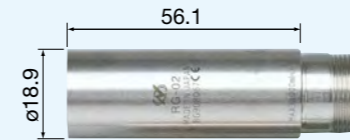

30,000 min⁻¹ Max.

- Mounted between an attachment and a motor.
- The speed is reduced to 1/15 but the torque is multiplied by 15 times.
- Suitable for high torque grinding process or drilling.

◆ Weight : 93 g

Standard Accessories
 • Pin Spanner (K-233) : 1 pc.

Extension Joint

Code No. **1015** Model **CN-01**

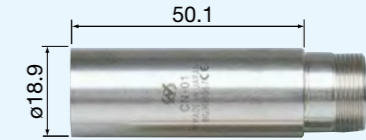

35,000 min⁻¹ Max.

- Speed Ratio 1 : 1
- This is a joint to be connected between a motor and an attachment to extend the total length of the attachment.

◆ Weight : 83 g

Standard Accessories
 • Pin Spanner (K-233) : 1 pc.

Foot Controller

Code No. **8106** Model **FC-64**

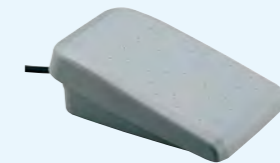

- Used as an ON/OFF switch as well as a variable speed control.
- For Emax EVolution (NE249)

Emax EVolution Torque Set

1,000~25,000 min⁻¹



For heavy duty and larger tools, Torque type promises to extend operation ranges. One-touch ring type bur replacement.

Ring Type IR-310 is the standard attachment for Emax EVolution torque set EV250-120, EV250-230.

Code No. **8234** (120V) Model **EV250-120**

Code No. **8226** (230V) Model **EV250-230**

*Please check the power source plug type (P.58).

Standard Equipment

- Micro Grinder (IR-310+ENK-250T) : 1 pc.
- Collet ø3.0 mm (CHH-3.0), ø2.35 mm (CHH-2.35) : 1 pc. each
- Controller (NE249) : 1 pc.
- Accessories : Handpiece Holder : 1 pc., Handpiece Stand : 1 pc. Power Supply Cord : 1 pc., Spanner (7 x 5.1) : 1 pc. Pin Spanner (K-233) : 1 pc., L Shaped Spanner (9) : 1 pc.

Precautions for using Nakanishi Tools

For safe use of the tools





- Please read operation manuals before using any tools.
- Please keep all operation manuals on hand for reference whenever necessary.

Caution Incorrect use of the tools, or ignoring 'CAUTIONS for safety' described in the operating manuals, could cause fatal or serious bodily injury.

CAUTIONS

 <p>Always use safety glasses, mask, face guard for your safety.</p>	 <p>Fasten the collet firmly. Make sure the tool is fully installed in the collet to avoid tool slippage.</p>										
 <p>Do not touch the tools when in operation. Make sure the work area is neat and there is sufficient light.</p>	 <p>Do not use damaged or broken electric cords and air hoses.</p>										
 <p>Do not use the tool where flammable liquids or gases exist.</p>	 <p>Start at low speed and increase gradually to insure safe work. This is particularly important for the use of new tools, large cutting tools and elastic tools such as rubber grindstone, sander and brush tools.</p>										
 <p>Do not leave operating tools. Confirm that the tool has stopped completely after switching off.</p>	 <p>Keep the tools and products in a cool, dry place.</p>										
 <p>Select proper tools and products for your application. Select tools carefully considering the performance of the tools, work procedure and type/shape of the material.</p>	 <p>Check the tools carefully before use. Confirm that the tools are free of chips, cracks, splits, scratches, irregular bondings, and out of round shanks, etc.</p>										
 <p>Fix the work material firmly in a vise and/or other clamping fixture.</p>	 <p>Stop grinding or polishing immediately whenever unusual sounds, vibrations, or wear are found. Restart the work only after the problem is found and corrected.</p>										
 <p>Do not wear loose clothing and/or accessories that may be caught in machinery. Long hair should be secured prior to machine operation.</p>	 <p>Only use attachments, parts, consumable articles and accessories produced by NAKANISHI.</p>										
 <p>Check all tools carefully before use. Clean the inside of the collet and tool shank, chips or fine metals inside the collet could cause tool slippage and result in damage to machinery or bodily injury.</p>	 <p>Do not apply high pressure to or pry with the tools. This can break and/or bend the tools. Use the tools within their design limitation. Excessive pressure will decrease the efficiency of your work and cause excessive wear of the tools.</p>										
 <p>The tools should be used by taking care of the overhang and below maximum allowable speed. The catalogue shows the maximum allowable speed at 13 mm overhang (distance between the face of the collet and the top of the tool shank).</p>	<p>Decrease the speed as shown in the table below, if you are using a longer overhang than 13 mm.</p> <table border="1"> <thead> <tr> <th>Overhang</th> <th>Maximum allowable speed (min⁻¹)</th> </tr> </thead> <tbody> <tr> <td>Less than 13 mm</td> <td>Shown in the catalogue (A)</td> </tr> <tr> <td>Less than 20 mm</td> <td>(A) x 0.5</td> </tr> <tr> <td>Less than 25 mm</td> <td>(A) x 0.3</td> </tr> <tr> <td>Less than 50 mm</td> <td>(A) x 0.1</td> </tr> </tbody> </table>	Overhang	Maximum allowable speed (min ⁻¹)	Less than 13 mm	Shown in the catalogue (A)	Less than 20 mm	(A) x 0.5	Less than 25 mm	(A) x 0.3	Less than 50 mm	(A) x 0.1
Overhang	Maximum allowable speed (min ⁻¹)										
Less than 13 mm	Shown in the catalogue (A)										
Less than 20 mm	(A) x 0.5										
Less than 25 mm	(A) x 0.3										
Less than 50 mm	(A) x 0.1										

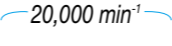
Symbols used in NAKANISHI Tools Catalogue

	<p>Shank Diameter Shows shank diameter of the tools. Nakanishi produces tools with several shank diameters. * Nakanishi micro grinders utilize a collet system, which insures maximum precision. Therefore, please use the collet that best corresponds to the tool shank diameter.</p>
	<p>Standard Package One package is the minimum shipping unit. This number shows the number of pieces in the standard package (bag, box and etc.). Please order the number of packages needed for the desired quantity.</p>
	<p>Maximum allowable speed Do not exceed the maximum allowable tool speed. For your safety, use the tools below the indicated allowable speed. Start at low speed and increase gradually to insure safety. The preceding is particularly important for the use of new tools and machines. * Maximum allowable speed assumes an overhang of less than 13mm. Decrease speed if the overhang is more than 13mm. Refer to "Precautions for using Nakanishi Tools" on the next page. * Check the tools and machinery for mechanical defects prior to each use.</p>
	<p>Grit This shows grain size of various grinding tools.</p> <p>Rough Cutting..... 46, 54, 60, 70, 80, 90 Medium Cutting..... 100, 120, 150, 180 Pre Finishing..... 220, 240, 280, 320, 400 Finishing..... 500, 600, 700, 800, 1000 Fine Finishing and Mirror Polishing..... 1200, 1500, 1800, 2000, 3000, 4000, 6000, 8000</p>

Code No. **62801~** End Code number on each page

NAKANISHI's EXCLUSIVE TOOLS

SHANK Ø3.0 Code number (Order number)

1 pc./pack Electroplated Diamond File

<p>Flat taper 1/15 Thickness 1.4 Grit #200 62801 #400 62802 #600 62803</p> <p>Flat taper 1/15 Thickness 1.4 Grit #200 62805 #400 62806 #600 62807</p> <p>Flat 1.5/20 Grit #150 62811 #200 62812 #400 62813</p> <p>Flat (Single side electroplating) 1.2/20 Grit #100 62814</p> <p>Flat 1.4/20 Grit #150 62815 #200 62816 #400 62817</p> <p>Flat (Single side electroplating) 1/15 Grit #150 62821 #200 62822 #400 62823</p> <p>Flat (Single side electroplating) 1.5/20 Grit #150 62825 #200 62826 #400 62827</p>	<p>Angular 2/15 Grit #200 62804 #400 62808 #600 62809</p> <p>Round ø1/15 Grit #200 62810 #400 62814 #600 62815</p> <p>Round ø2/20 Grit #200 62816 #400 62817</p> <p>Round ø3/25 Grit #200 62818 #400 62819</p> <p>Round taper ø1.5/25 Grit #200 62820 #400 62824</p> <p>Half-round 1.5/15 Grit #200 62828 #400 62829</p> <p>Half-round 2/20 Grit #200 62830 #400 62831</p> <p>Triangular 2.5/41 Grit #200 62832 #400 62833</p>
---	--

SHANK Ø3.0 Standard package quantity

15 pcs./pack Special Rubber Pad For Abrasive and

SHANK Ø3.0 Shank diameter of the tool

Exclusive Tools of "50° & 90° ANGLE" Maximum allowable speed

Special tools for Nakanishi Micro-grinder "Angle Attachment". Highly efficient for grinding, polishing, finishing, etc.

SHANK Ø3.0 Total length of the tool (mm)

20,000 min⁻¹

Note : Specifications may be changed without notice. Colors of the tools in this catalogue may not be the same as actual colors due to printing limitations.

NAKANISHI's EXCLUSIVE TOOLS

NAKANISHI's EXCLUSIVE TOOLS

Exclusive Tools of Electromotive Polisher "LUSTER", "MINI-LUSTER", "SWING-LUSTER"



LUSTER

Best for finishing large open work areas.

1 pc./pack Stone Holder



Maximum clamping thickness 4.5 x Width 11 mm (62502)

Maximum clamping thickness 11 x Width 13.5 mm (62505)

Angle can be freely set (90°)

SHANK 03.0

1 pc./pack Electroplated Diamond File

Flat taper	Thickness 1.4	Grit # 200	62301	Half-round	2	Grit # 150	62313
Flat taper	Thickness 1.4	Grit # 400	62302	Round	03	Grit # 150	62315
Flat	72-62307	Grit # 600	62303	Angular	2.5	Grit # 150	62317
Flat	72-62307	Grit # 200	62305				
Flat	72-62307	Grit # 400	62306				
Flat	72-62307	Grit # 600	62307				
Flat	72-62307	Grit # 150	62311				

2 pcs./pack Ceramic Fiber Grindstone (Total Length 50 mm)

Alumina fiber abrasive with the strength and the flexibility for rough or fine finishing.

Grit	Color	W = 4 mm	W = 6 mm	W = 10 mm	Grit	Color	W = 4 mm	W = 6 mm	W = 10 mm	Grit	Color	W = 4 mm	W = 6 mm	W = 10 mm
# 180	Ivory	60701	60711	62961	# 180	Ivory	60721	60731	62962	# 180	Ivory	63101	63102	63103
# 300	Brown	60702	60712	62963	# 300	Brown	60722	60732	62964	# 300	Red	63104	63105	63106
# 400	Orange	60703	60713	62965	# 400	Orange	60723	60733	62966	# 400	Orange	63107		
# 600	Black	60704	60714	62967	# 600	Black	60724	60734	62968	# 600	Black			
# 800	Blue	60705	60715		# 800	Blue	60725	60735		# 800	Blue			
# 1,000	White	60706	60716		# 1,000	White	60726	60736		# 1,000	White			
# 1,200	Pink	60707	60717		# 1,200	Pink	60727	60737		# 1,200	Pink			

1 pc./pack Diamond File Flat Type

*Use with stone holder No.62502.

Grit # 150	62351	Grit # 150	62361
Grit # 200	62352	Grit # 200	62362
Grit # 400	62353	Grit # 400	62363

1 pc./pack Ceramic Fiber Grindstone Holder - Grindstone Holder

Maximum clamping thickness 1 x Width 4 mm	62506	Maximum clamping thickness 1 x Width 10 mm	62508	Grindstone Holder	Maximum clamping thickness 3 x Width 6 mm	62509
Maximum clamping thickness 1 x Width 6 mm	62507	Maximum clamping thickness 1 x Width 6 mm	62510			

SHANK 03.0, 03.5

3 pcs./pack Precision Finishing Files (Flat, Round, Angular, Triangular, Half-Round)

Total length The length of file	140mm 70mm		180mm 90mm	
	Standard	Fine	Standard	Standard
1(1.3) (Flat)	57301	57311	57321	
3(3.5) (Round)	57302	57312	57322	
2.5(2.7) (Angular)	57303	57313	57323	

5 files-pack set

- Standard (total length 140mm) set (No.57301~No.57305 : 1pc. each) 57309
- Fine (total length 140mm) set (No.57311~No.57315 : 1pc. each) 57319
- Standard (total length 180mm) set (No.57321~No.57325 : 1pc. each) 57329

1 pc./pack Flat Holder

Tip for use with abrasive sheets.

62512, 62982

SHANK 03.0

3 pcs./pack Rasps for plastics and wood working (Flat, Round, Angular, Triangular, Half-Round)

(Flat)	57401	(Triangular)	57404
(Round)	57402	(Half-round)	57405
(Angular)	57403		

5 files-pack set

Rasps set for plastics and wood working for plastics and woodworking (No.57401~No.57405 : 1pc. each) 57410

1 pc./pack Angular Pad Holder

Holder for use with abrasive tips for polishing flat surfaces.

62521, 62525, 62526, 62527, 62751

20 pcs./pack Felt Tip **100 pcs./pack Sand Paper Tip**

Grit	#	Grit	#
# 120	62552	# 600	62557
# 180	62553	# 800	62558
# 240	62554	# 1,000	62559
# 320	62555	# 1,500	62560
# 400	62556		

3 pcs./pack Wood Tip Holder

62621, 62622, 62623

1 pc./pack Spring Holder

62751

*Mountable shaft diameter range $\phi 1-\phi 3.3$ mm

NAKANISHI's EXCLUSIVE TOOLS

SHANK $\phi 3.0$

1 pc./pack Electroplated Diamond File

Profile	Thickness	Grit	Code
Flat taper	0.5 mm	# 200	62801
	0.4 mm	# 400	62802
	0.35 mm	# 600	62803
Flat taper	0.5 mm	# 200	62805
	0.4 mm	# 400	62806
	0.35 mm	# 600	62807
Flat	# 150	# 200	62811
	# 200	# 400	62812
	# 400	# 600	62813
Flat (Single side electroplating)	# 100	# 200	62814
	# 150	# 200	62815
	# 200	# 400	62816
Flat	# 150	# 200	62821
	# 200	# 400	62822
	# 400	# 600	62823
Flat (Single side electroplating)	# 150	# 200	62825
	# 200	# 400	62826
	# 400	# 600	62827
Angular	# 150	# 200	62831
	# 200	# 400	62832
	# 400	# 600	62833
Round	# 100	# 200	62840
	# 150	# 200	62841
	# 200	# 400	62842
Round	# 150	# 200	62845
	# 200	# 400	62846
	# 400	# 600	62847
Round	# 150	# 200	62851
	# 200	# 400	62852
	# 400	# 600	62853
Round taper	# 150	# 200	62855
	# 200	# 400	62856
	# 400	# 600	62857
Half-round	# 150	# 200	62865
	# 200	# 400	62866
	# 400	# 600	62867
Half-round	# 150	# 200	62871
	# 200	# 400	62872
	# 400	# 600	62873
Triangular	# 150	# 200	62881
	# 200	# 400	62882
	# 400	# 600	62883

NAKANISHI's EXCLUSIVE TOOLS

100 pcs./pack Zirconium Disk

Best for finishing aluminum, stainless steel, copper alloy, brass, etc.



Grit	o11	o21	o31
# 60	64251	64261	64271
# 80	64252	64262	64272
# 120	64253	64263	64273
# 150	64254	64264	64274

Adhesive Back

20 pcs./pack Fiber Disk

Soft finishing can be done on flat & curved surfaces, due to superior flexibility.



Grit	Color	o11	o21	o31
# 120	Brown	64281	64291	64301
# 240	Violet	64282	64292	64302
# 320	Red Brown	64283	64293	64303
# 600	Dark Blue	64284	64294	64304
# 800	Gray	64285	64295	64305
# 1,000	Orange	64286	64296	64306

*Thickness 3 mm Adhesive Back

20 pcs./pack Felt Disk

Ideal for finishing using abrasives and diamond compounds.



Description	o11	o21	o31
Hard Type Felt Disk (1mm thickness)	64326		
Soft Type Felt Disk (1mm thickness)	64331	64332	64333
Soft Type Felt Disk (2mm thickness)	64335	64336	64337

Adhesive Back

20 pcs./pack Felt Disk Chromium Oxide (Blue Rouge) Embedded Type.

Useful for speedy finishing because of Chromium Oxide (Blue Rouge) Embedded.



Description	o11	o21	o31
Felt Disk Chromium Oxide (Blue Rouge) Embedded Type. (2mm thickness)	64341	64342	64343

Adhesive Back

20 pcs./pack Rubber Points Disk

Best for coarse finishing, pre-finishing with great polishing power.



Grit	Color	o20	o30
# 60	Brown	64391	64401
# 80	Red	64392	64402
# 120	Dark Green	64393	64403
# 180	Olive	64394	64404
# 220	Green	64395	64405
# 320	Brown	64396	64406

*Thickness 3.75 mm. Adhere to special rubber pads and use. Adhesive Back.

Exclusive Tools of "50° & 90° ANGLE"

Special tools for Nakanishi Micro-grinder "Angle Attachment". Highly efficient for grinding, polishing, finishing, etc.

SHANK $\phi 3.0$

5 pcs./pack Special Rubber Pad For Abrasive and Felt Disks

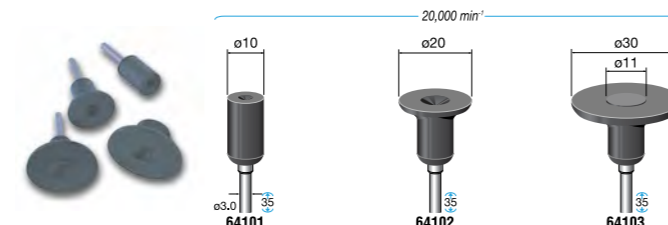

o10 64101, o20 64102, o30 64103

SHANK $\phi 3.0$

5 pcs./pack Mounted Rubber Disks (Rubber Pad Integration)

Moderately hard abrasive grain have great polishing ability.



Grit	Color	WA	GC
# 80	Pink	64411	64421
# 120	Blue	64412	64422
# 180	Yellow	64413	64423
# 220	Green	64414	64424
# 320	Purple	64415	64425
# 500	Brown	64416	64426

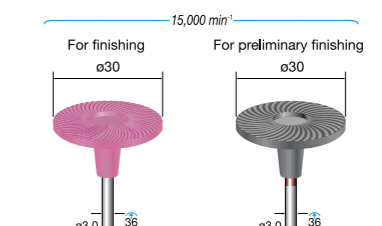

Grit	Color	WA
# 80	Black (Red Line)	64431
# 120	Black (Blue Line)	64432

100 pcs./pack Sand Paper Disk

Cloth Type
For Metals ... Both for dry and wet finishing (Adhesive is resistant to water and oil)

Paper Type
For Metals ... Both for dry and wet finishing (Adhesive is resistant to water and oil)

Paper Type
Dry type ... For Metal, Woodwork, Paint, Putty polishing, Dry use

Grit	o11	o21	o31
# 60	64111	64121	64141
# 80	64112	64122	64142
# 120	64113	64123	64143
# 180	64114	64124	64144
# 240	64115	64125	64145
# 320	64116	64126	64146
# 400	64117	64127	64147
# 600	64118	64128	64148
# 800	64119	64129	64149
# 1,000	64120	64130	64150

Adhesive Back

Grit	o11	o21	o31
# 80	64131	64151	64171
# 120	64132	64152	64172
# 180	64133	64153	64173
# 240	64134	64154	64174
# 320	64135	64155	64175
# 400	64136	64156	64176
# 600	64137	64157	64177
# 800	64138	64158	64178
# 1,000	64139	64159	64179
# 1,500	64140	64160	64180

Adhesive Back

Grit	o11	o21	o31
# 80	64201	64211	64221
# 120	64202	64212	64222
# 180	64203	64213	64223
# 240	64204	64214	64224
# 320	64205	64215	64225
# 400	64206	64216	64226
# 600	64207	64217	64227

Adhesive Back

1 pc./pack Diamond Disk (Fully Electroplated Type)

Superior in sharpness and durability.



Grit	o11	o21	o31
# 100	64451	64461	64471
# 140	64452	64462	64472
# 200	64453	64463	64473
# 280	64454	64464	64474
# 400	64455	64465	64475
# 600	64456	64466	64476
# 800	64457	64467	64477
# 1,000	64458	64468	64478

Adhesive Back

1 pc./pack Diamond Disk (Dot Electroplated Type, Wet Type)

Electroplated nickel-alloy pellet is strongly adhered to resin base.



Grit	Color	o11	o21	o31
# 60	Green	64501	64511	64521
# 120	Black	64502	64512	64522
# 200	Red	64503	64513	64523
# 400	Yellow	64504	64514	64524
# 800	Gray	64505	64515	64525

Adhesive Back

NAKANISHI's EXCLUSIVE TOOLS

3 pcs./pack Resin Bond Diamond Disk Star Pattern



Grit	Color	ø11	ø21	ø31
# 80	64531	64541	64551	
# 120	64532	64542	64552	
# 180	64533	64543	64553	
# 240	64534	64544	64554	
# 400	64535	64545	64555	
# 600	64536	64546	64556	
# 800	64537	64547	64557	
# 1,000	64538	64548	64558	
# 2,000	64539	64549	64559	

Adhesive Back

*Patterns may be changed without notice

1 pc./pack Resin Bond Diamond Disk Dot Type



Grit	Color	ø11	ø21	ø31
# 500	Yellow	64571	64581	64591
# 1,000	Blue	64572	64582	64592
# 3,000	Orange	64573	64583	64593

Adhesive Back

SHANK ø3.0



• Plastic and brass lapping rings for use with abrasive and diamond compounds.

10 pcs./pack Replacement Plastic Ring

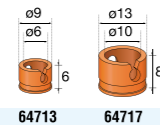

64713 64717

5 pcs./pack Replacement Brass Ring

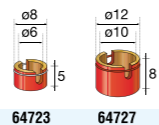

64723 64727

*Do not use the same ring for different abrasive compound grits.

1 pc./pack Replacement Holder

For internal diameter ø6 mm For internal diameter ø10 mm

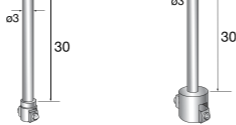

64731 64732

Exclusive Tools of "90° MINI ANGLE TYPE ATTACHMENT"



Steel cutters for radius grinding of deep cross holes for "Mini-Angle attachment". Ideal for radius grinding of holes or removing burrs from cross jigs, precision parts and inside surfaces of pipes.



MINI ANGLE TYPE Attachment (Very Small Head)

MINI ANGLE TYPE Attachment

SHANK ø1.6

1 pc./pack Steel Cutters For Deep Cross Hole Finishing

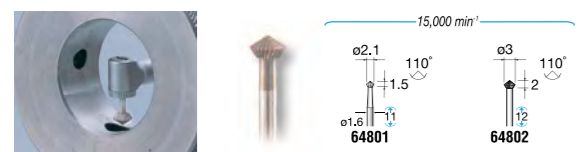

15,000 min⁻¹
ø2.1 110° ø1.5 110°
64801 64802

SHANK ø1.6

1 pc./pack Diamond Coated Burs For Deep Cross Hole Finishing

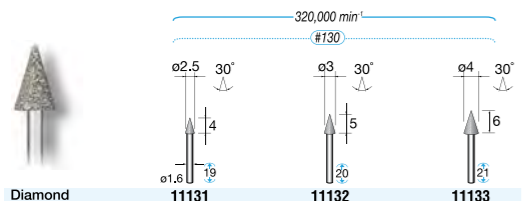

320,000 min⁻¹ #130
ø2.5 30° ø3 30° ø4 30°
ø1.6 19 20 21
Diamond 11131 11132 11133

5 pcs./pack Diamond and CBN Coated Burs For Deep Cross Hole Finishing

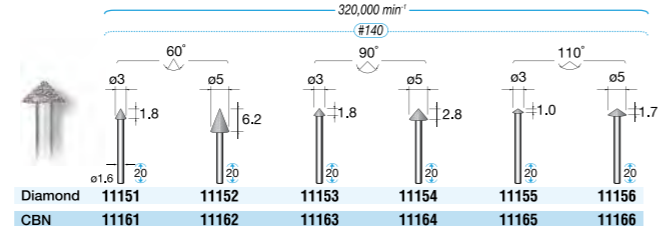

320,000 min⁻¹ #140
ø3 60° ø5 60° ø3 90° ø5 90° ø3 110° ø5 110°
ø1.6 20 20 20 20 20 20
Diamond 11151 11152 11153 11154 11155 11156
CBN 11161 11162 11163 11164 11165 11166

NAKANISHI's EXCLUSIVE TOOLS

Exclusive Tools of "IMPULSE"



Special tools for Nakanishi Micro-grinder "IMPULSE". Excellent for grinding or polishing flat surfaces, edges with Nakanishi's high-power air grinder.



90° ANGLE IMPULSE · NA90-230

60° ANGLE IMPULSE · NA45-230

5 pcs./pack Special Rubber Pad for Disk Abrasives

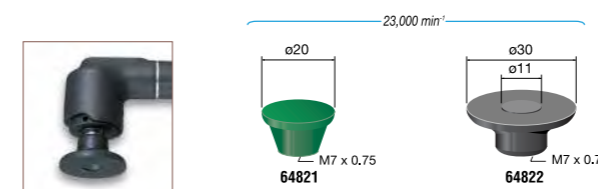

23,000 min⁻¹
ø20 M7 x 0.75 64821
ø30 ø11 M7 x 0.75 64822

12 pcs./pack Cup Wheel

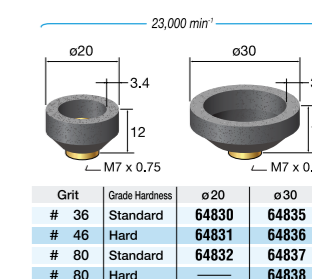

23,000 min⁻¹
ø20 3.4 12 M7 x 0.75
ø30 3.7 13 M7 x 0.75

Grit	Grade Hardness	ø20	ø30
# 36	Standard	64830	64835
# 46	Hard	64831	64836
# 80	Standard	64832	64837
# 80	Hard	—	64838

5 pcs./pack Polishing Sander

• Abrasive Disk for high speed rotation is made from overlapping abrasive cloths.



23,000 min⁻¹
ø30 M7 x 0.75

Grit	Color
# 80	64842
# 120	64844
# 180	64846
# 240	64847
# 400	64849

• Convenient Assorted set for trial polishing
All grain size (5 types x each 1 pc.)
Total 5 pcs.-pack 64850

10 pcs./pack Rubber Cup Wheel

• Rubber Cup Wheel with high elasticity for grinding & polishing.



23,000 min⁻¹
ø30 M7 x 0.75

Grit	Color
# 60	Brown
# 80	Red
# 120	Blue
# 180	Olive
# 220	Green
# 320	Brown

• Convenient Assorted set for trial polishing
All grain size (6 types x each 2 pcs.)
Total 12 pcs.-pack 64859

Exclusive Tools of "FINE BELT SANDER"



FINE BELT SANDER Attachment

30 pcs./pack Abrasive Belts

• High Quality Abrasive Belts are superior in grinding & durability.



For Grinding or Polishing of Metals (Length 300 mm)

Grit	W = 4 mm	W = 6 mm	W = 8 mm
# 80	64901	64911	64921
# 120	64902	64912	64922
# 180	64903	64913	64923
# 240	64904	64914	64924
# 320	64905	64915	64925
# 400	64906	64916	64926
# 600	—	—	64927
# 800	—	—	64928

• Assorted set for preliminary finishing (● Mark)
Grain size (4 types x each 10 pcs.), W = 8 mm
Total 40 pcs.-pack 64931

• Assorted set for finishing (● Mark)
Grain size (4 types x each 10 pcs.), W = 8 mm
Total 40 pcs.-pack 64932



For Woodwork (Length 300 mm)

Grit	8 mm Width
# 80	64941
# 120	64942
# 240	64943

• Assorted set for woodwork
All grain size (3 types x each 10 pcs.)
Total 30 pcs.-pack 64955

NAKANISHI's EXCLUSIVE TOOLS

3 pcs./pack Diamond Belt

• For grinding and polishing of Carbide, Hardened steel, Steel, Special steels, Ceramic, FRP, etc.

Hard Type (Length 300 mm)

Grit	8mm Width
# 80	65011
# 120	65012
# 240	65014
# 320	65015
# 600	65017

• **Assorted set**
All grain size (5 types x each 1 pc.)
Total 5 pcs.-pack **65019**

Soft Type (Length 300 mm)

Grit	8mm Width	Grit	8mm Width
# 120	65021	# 600	65025
# 180	65022	# 800	65026
# 240	65023	#1,000	65027
# 320	65024		
# 400	65028		

• **Assorted set**
All grain size (8 types x each 1 pc.)
Total 8 pcs.-pack **65030**

30 pcs./pack Zirconium Belt

• Best for polishing aluminum, stainless steel, brass

(Length 300 mm)

Grit	8mm Width
# 80	64971
# 100	64972
# 120	64973

• **Assorted set**
All grain size (3 types x each 10 pcs.)
Total 30 pcs.-pack **64975**

5 pcs./pack Felt Belt

• Belt is made from high density wool on cloth base material.
For use with abrasive and diamond compounds.

(Length 300 mm)

8mm Width x 1mm Thickness	Code
	65101

Electrically Driven
EmaEVO ESPERT
Air Driven
ROTUS IMPULSE PRESTO II
General Parts
GENERAL PARTS
CAUTION
Exclusive Tools
EXCLUSIVE TOOLS
INDEX
Protective Equip.

Electrically Driven
EmaEVO ESPERT
Air Driven
ROTUS IMPULSE PRESTO II
General Parts
GENERAL PARTS
CAUTION
Exclusive Tools
EXCLUSIVE TOOLS
INDEX
Protective Equip.