

BRIDGESTONE

Holding Gently and Handling Securely...

AIR PICKER

AIR GRIPPER



AIR PICKER AIR GRIPPER

TABLE OF CONTENTS

AIR PICKER, AIR GRIPPER

Characteristics of AIR PICKER and AIR GRIPPER...**1**

AIR PICKER

Picking Inside an Object...**2**

AIR GRIPPER

Gripping Outside an Object...**3**

AIR PICKER

Specifications...**4**

AIR GRIPPER

Specifications...**7**

ACCESSORIES

Nose Cones, Fittings & Sleeves...**8**

DURABILITY LIFE / HANDLING PRECAUTIONS...**10**

BRIDGESTONE'S HIGH PERFORMANCE PNEUMATIC WORK HOLDING DEVICES:

Holding Products Softly and Securely with Wider Contact Area.

AIR PICKERs and AIR GRIPPERs are innovative pneumatic devices that hold the work-piece softly and securely with a wider contact area. They have a wide range of applications in manufacturing processes such as picking, shifting, transporting and loading products. They can even be used for sealing and stopper fitting. They are a key component in factory automation.

CHARACTERISTICS OF AIR PICKER AND AIR GRIPPER

1

Holding Work-Pieces Gently and Securely

Using a rubber tube that inflates to hold on to the work-piece, AIR PICKERs and AIR GRIPPERs hold the work-pieces with a wider contact area, eliminating damage during processing. They are especially suitable for holding soft or fragile objects.

2

Holding Work-Pieces having Multiple Diameters without Changing Parts

The tube inflates evenly around the body of AIR PICKER and AIR GRIPPER, enabling them to hold objects having a variety of diameters with the same size model. Unlike conventional grippers, there is no need of parts replacement work, such as changing the chuck portion according to the diameter of the object.

3

Lightweight and Simple Construction

AIR PICKERs and AIR GRIPPERs are significantly light in weight when compared with conventional grippers. They are capable of carrying a load that is 25 to 100 times greater than their own weight.



AIR PICKER

Picking Inside an Object

A cylindrical rubber tube inflates in a doughnut shape when pressurized, allowing the AIR PICKER to hold on to the inner wall of the object with a wide contact area. Thus, it holds the work-piece gently and securely without causing damage.

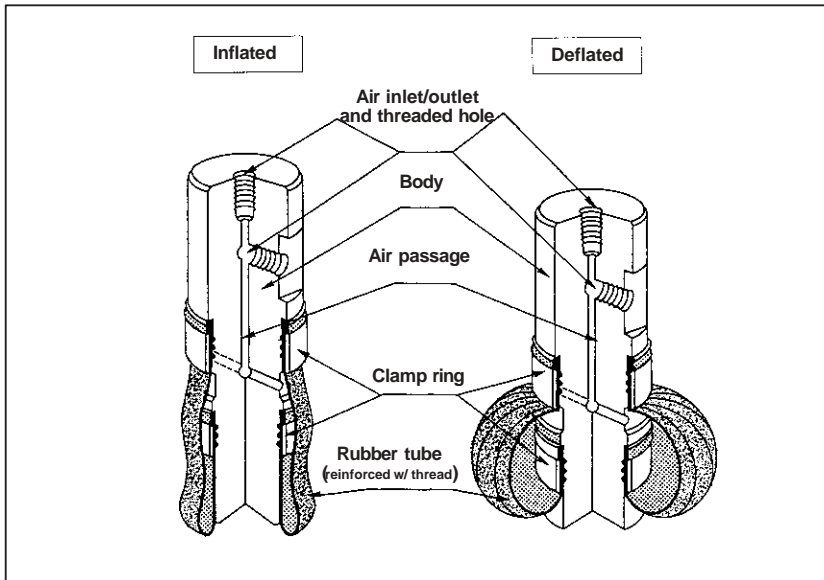

●R-type

The rubber tube is reinforced with nylon threads woven into it radially. R-type is suitable for holding and handling work-pieces having small- to medium-sized diameters, or work having medium weights.

●T-type

The rubber tube is reinforced with nylon threads woven into it on the bias. T-type is suitable for holding and handling work-pieces having large-sized diameters, or work-pieces having heavy weights.

Note: Do not inflate AIR PICKER unrestricted.



0 MPa / 0 psi



0.15 MPa / 21.8 psi



0.3 MPa / 43.5 psi



AIR GRIPPER

Gripping Outside an Object

A doughnut-shaped rubber tube inflates inwardly when pressurized, allowing the AIR GRIPPER to hold the exterior of the object with a wide contact area. Thus, it holds the work-piece gently and securely without causing damage.

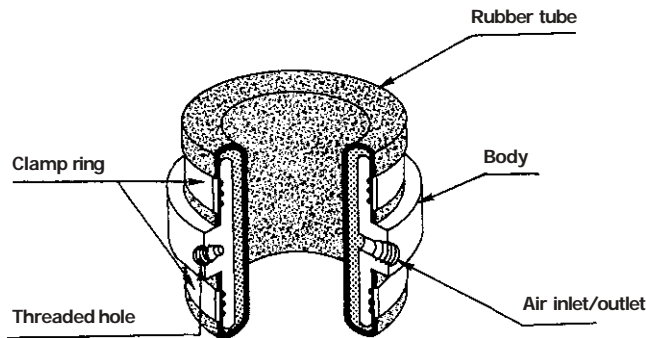

● The AIR GRIPPER softly holds the exterior of the work piece. It is suitable for holding and handling a work piece having no opening or having too small an opening to allow an AIR PICKER to hold it from within. The standard AIR GRIPPER models have all rubber construction that uses no reinforcement thread. R-type models, which are reinforced with nylon thread, are also available on a special-order basis.

0 MPa / 0 psi

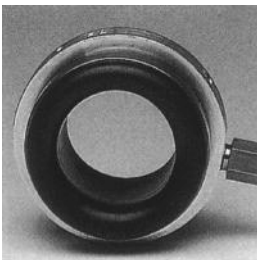

0.15 MPa / 21.8 psi

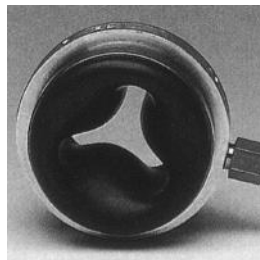

0.3 MPa / 43.5 psi

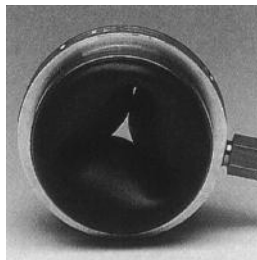

Note: Do not inflate AIR GRIPPER unrestricted.

Model Number Configuration

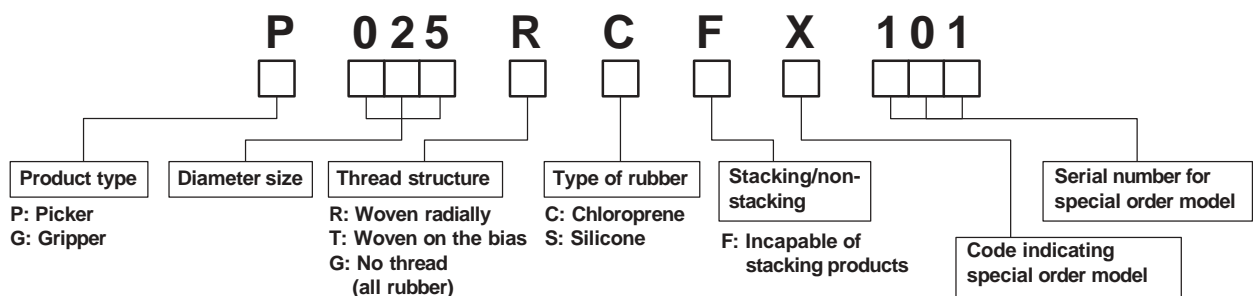

Air Picker - Chloroprene

• P006RCF ~ P055TCF

	P006RCF ~ P009RCF	P010RCF	P014RCF ~ P025RCF	P035TCF ~ P055TCF
Max Operating Air Pressure (MPa / psi)	0.4 / 58.0	0.4 / 58.0	0.5 / 72.5	0.5 / 72.5
Body Material	Stainless Steel	Free-Cutting Steel (Plated)	Free-Cutting Steel (Plated)	Aluminum (Alumite)
Rubber Bladder Material	Chloroprene	Chloroprene	Chloroprene	Chloroprene
Fabric Reinforcement	Radial Woven	Radial Woven	Radial Woven	Bias Woven

• P006RCF ~ P009RCF

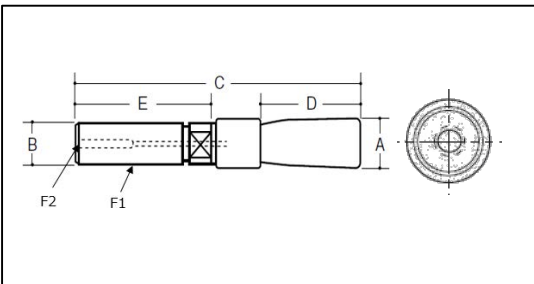

• P010RCF ~ P055TCF

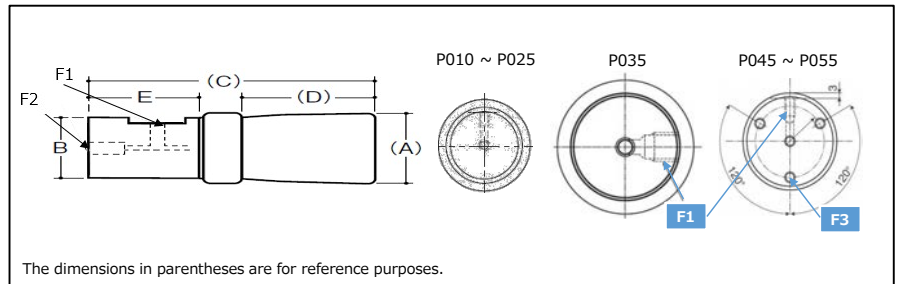

A: rubber tube outside diameter | B: body outside diameter | C: total length | D: rubber tube length | F: threaded port / mounting hole

Part Number (Bridgestone Model #)	Former Firestone Part Number	Workpiece Inside Diameter (mm)	Recommended Handling Load* (g)	A (mm)	B (mm)	C (mm)	D (mm)	E (mm)	F1	F2	F3	G	Mass (g)
RBP006RCA (P006RCF)	WP1M580001	8.5 - 10	300	8	6	51	17.5	24.5	M6	M3	N/A	N/A	8
RBP007RCA (P007RCF1)	WP1M580002	10 - 12	300	9.5	6	51	17.5	24.5	M6	M3	N/A	N/A	12
RBP009RCA (P009RCF1)	WP1M580003	12 - 16	1,200	11	8	51	17.5	24.5	M8	M5	N/A	N/A	17
RBP010RCA (P010RCF)	---	16 - 21	2,000	14	10	52	21	22	M5	M5	N/A	N/A	28
RBP014RCA (P014RCF)	---	21 - 27	2,500	19	14	56	22	22	M5	M5	N/A	N/A	60
RBP017RCA (P017RCF)	---	24 - 32	3,000	22	17	56	22	22	M5	M5	N/A	N/A	85
RBP019RCA (P019RCF)	---	28 - 36	3,500	25	19	55	22	22	M5	M5	N/A	N/A	105
RBP022RCA (P022RCF)	---	30 - 44	6,000	27	22	64	28	25	M5	M5	N/A	N/A	160
RBP025RCA (P025RCF)	---	32 - 52	9,000	29	25	75	34	30	M5	M5	N/A	N/A	245
RBP035TCA (P035TCF)	---	45 - 65	12,000	43.5	34	71	42	17.5	Rc 1/8	M6	N/A	N/A	180
RBP045TCA (P045TCF)	---	58 - 85	20,000	53.5	44	90	52	26	M6	M6	M6	N/A	370
RBP055TCA (P055TCF)	---	70 - 105	25,000	65.5	54	101	53	35	M6	M6	M6	N/A	610

*Recommended handling load for the maximum work inside diameter (load capability increases as the work inside diameter decreases)

Air Picker - Chloroprene with Nose Cone Mounting Hole

• P010RCFX ~ P055TCFX

	P010RCFX	P014RCFX ~ P025RCFX	P035TCFX ~ P055TCFX
Max Operating Air Pressure (MPa / psi)	0.4 / 58.0	0.5 / 72.5	0.5 / 72.5
Body Material	Free-Cutting Steel (Plated)	Free-Cutting Steel (Plated)	Aluminum (Alumite)
Rubber Bladder Material	Chloroprene	Chloroprene	Chloroprene
Fabric Reinforcement	Radial Woven	Radial Woven	Bias Woven

• P010RCFX ~ P055TCFX

P010 ~ P025 P035 P045 ~ P055

A: rubber tube outside diameter
 B: body outside diameter
 C: total length
 D: rubber tube length
 F: threaded port / mounting hole
 G: threaded nose cone mounting hole

The dimensions in parentheses are for reference purposes.

Part Number	Former Firestone Part Number	Workpiece Inside Diameter (mm)	Recommended Handing Load* (g)	A (mm)	B (mm)	C (mm)	D (mm)	E (mm)	F1	F2	F3	G	Mass (g)
P010RCFX910	WP13582000	16 - 21	2,000	14	10	52	21	22	10-32 UNF	10-32 UNF	N/A	8-32 UNC	28
P014RCFX910	WP13582001	21 - 27	2,500	19	14	56	22	22	10-32 UNF	10-32 UNF	N/A	10-24 UNC	60
P017RCFX910	WP13582002	24 - 32	3,000	22	17	56	22	22	1/8-27 NPT	1/8-27 NPT	N/A	10-24 UNC	85
P019RCFX910	WP13582003	28 - 36	3,500	25	19	55	22	22	1/8-27 NPT	1/8-27 NPT	N/A	10-24 UNC	105
P022RCFX910	WP13582004	30 - 44	6,000	27	22	64	28	25	1/8-27 NPT	1/8-27 NPT	N/A	10-24 UNC	160
P025RCFX910	WP13582005	32 - 52	9,000	29	25	75	34	30	1/8-27 NPT	1/8-27 NPT	N/A	1/4-20 UNC	245
P035TCFX910	WP13582006	45 - 65	12,000	43.5	34	71	42	17.5	1/8-27 NPT	1/8-27 NPT	N/A	1/4-20 UNC	180
P045TCFX910	WP13582007	58 - 85	20,000	53.5	44	90	52	26	1/8-27 NPT	1/8-27 NPT	10-24 UNC	1/4-20 UNC	370
P055TCFX910	WP13582008	70 - 105	25,000	65.5	54	101	53	35	1/8-27 NPT	1/8-27 NPT	10-24 UNC	1/4-20 UNC	610
P010RCFX911	WP1M580004	16 - 21	2,000	14	10	52	21	22	M5	M5	N/A	8-32 UNC	28
P014RCFX911	WP1M580005	21 - 27	2,500	19	14	56	22	22	M5	M5	N/A	10-24 UNC	60
P017RCFX911	WP1M580006	24 - 32	3,000	22	17	56	22	22	M5	M5	N/A	10-24 UNC	85
P019RCFX911	WP1M580007	28 - 36	3,500	25	19	55	22	22	M5	M5	N/A	10-24 UNC	105
P022RCFX911	WP1M580008	30 - 44	6,000	27	22	64	28	25	M5	M5	N/A	10-24 UNC	160
P025RCFX911	WP1M580009	32 - 52	9,000	29	25	75	34	30	M5	M5	N/A	1/4-20 UNC	245
P035TCFX911	WP1M580011	45 - 65	12,000	43.5	34	71	42	17.5	Rc 1/8	M6	N/A	1/4-20 UNC	180
P045TCFX911	WP1M580012	58 - 85	20,000	53.5	44	90	52	26	M6	M6	M6	1/4-20 UNC	370
P055TCFX911	WP1M580013	70 - 105	25,000	65.5	54	101	53	35	M6	M6	M6	1/4-20 UNC	610

*Recommended handing load for the maximum work inside diameter (load capability increases as the work inside diameter decreases)

Air Picker - Silicone with Nose Cone Mounting Hole

• P014RSFX ~ P035RSFX

	P010RSFX ~ P022RSFX	P025RSFX	P035RSFX
Max Operating Air Pressure (MPa / psi)	0.22 / 31.9	0.22 / 31.9	0.18 / 26.1
Body Material	Free-Cutting Steel (Plated)	Aluminum (Alumite)	Aluminum (Alumite)
Rubber Bladder Material	Silicone	Silicone	Silicone
Fabric Reinforcement	None	None	None

• P010RSFX ~ P035RSFX

P010 ~ P025 P035

A: rubber tube outside diameter
 B: body outside diameter
 C: total length
 D: rubber tube length
 E: threaded port / mounting hole
 G: threaded nose cone mounting hole

The dimensions in parentheses are for reference purposes.

Part Number	Former Firestone Part Number	Workpiece Inside Diameter (mm)	Recommended Handling Load* (g)	A (mm)	B (mm)	C (mm)	D (mm)	E (mm)	F1	F2	F3	G	Mass (g)
P014RSFX910	WP13582009	22 - 25	600	20	14	56	22	22	10-32 UNF	10-32 UNF	N/A	10-24 UNC	60
P014RSFX911	WP1M580024	22 - 25	600	20	14	56	22	22	M5	M5	N/A	10-24 UNC	60
P017RSFX911	WP1M580025	25 - 30	700	23	17	56	22	22	M5	M5	N/A	10-24 UNC	85
P019RSFX911	WP1M580018	30 - 35	1,000	27	19	55	22	22	M5	M5	N/A	10-24 UNC	110
P022RSFX911	WP1M580026	32 - 40	1,300	29	22	64	28	25	M5	M5	N/A	10-24 UNC	165
P025RSFX911	WP1M580019	34 - 42	1,600	31	25	75	34	30	M5	M5	N/A	1/4-20 UNC	110
P035RSFX911	WP1M580028	46 - 58	2,500	42	34	71	42	17.5	Rc 1/8	M6	N/A	1/4-20 UNC	180

*Recommended handling load for the maximum work inside diameter (load capability increases as the work inside diameter decreases)

Air Gripper

• G020 ~ G050

	G***GCF	G***GSFX100	G***GCFX200
Max Operating Air Pressure (MPa / psi)	0.15 / 21.8	0.1 / 14.5	0.15 / 21.8
Body Material	Aluminum (Alumite)	Aluminum (Alumite)	Aluminum (Alumite)
Rubber Bladder Material	Chloroprene	Silicone	Chloroprene
Fabric Reinforcement	None	None	None

• G020 ~ G050

The drawings show a side view and a top view of the air gripper. The side view labels dimensions A (rubber tube inside diameter), B (rubber tube outside diameter), C (maximum diameter including flange), D (height including flange), E (flange height), F (threaded mounting hole), and G (threaded port). The top view shows a 94° angle and a 1mm gap.

A: rubber tube inside diameter
 B: rubber tube outside diameter
 C: maximum diameter (including flange)
 D: height (including flange)
 E: flange height
 F: threaded mounting hole
 G: threaded port

The dimensions in parentheses are for reference purposes.

Part Number (Bridgestone Model #)	Former Firestone Part Number	Workpiece Outside Diameter (mm)	Recommended Handling Load* (g)	A (mm)	B (mm)	C (mm)	D (mm)	E (mm)	F1	G	Mass (g)
RBG020GCA (G020GCF)	WP1M585001	5 - 15	1,400	19	33	40	36	10	M5	M5	60
RBG030GCA (G030GCF)	WP1M585002	10 - 25	3,800	27	48	60	48	13	M6	M6	145
RBG040GCA (G040GCF)	WP1M585003	15 - 35	6,000	37	58	70	52	14	M6	M6	210
RBG050GCA (G050GCF)	WP1M585004	20 - 45	9,000	48	69	80	56	15	M8	Rc 1/8	285
G020GSFX100	WP1M585005	5 - 15	400	19	33	40	36	10	M5	M5	60
G030GSFX100	WP1M585006	10 - 25	1,200	27	48	60	48	13	M6	M6	130
G040GSFX100	WP1M585007	15 - 35	1,800	37	58	70	52	14	M6	M6	210
G050GSFX100	WP1M585008	20 - 45	2,600	48	69	80	56	15	M8	Rc 1/8	260
G020GCFX200	WP13587000	5 - 15	1,400	19	33	40	36	10	10-24 UNC	10-32 UNF	60
G030GCFX200	WP13587001	10 - 25	3,800	27	48	60	48	13	10-24 UNC	10-32 UNF	145
G040GCFX200	WP13587002	15 - 35	6,000	37	58	70	52	14	10-24 UNC	1/8-27 NPT	210
G050GCFX200	WP13587003	20 - 45	9,000	48	69	80	56	15	10-24 UNC	1/8-27 NPT	285

*Recommended handling load for the maximum work inside diameter (load capability increases as the work inside diameter decreases)

Accessories

• Nose Cone for P010

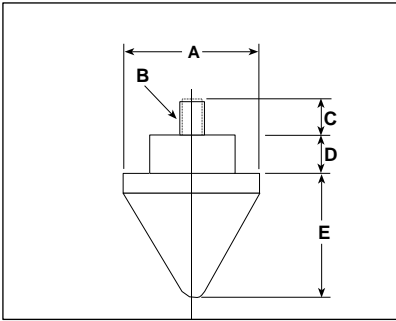

• Nose Cones for P014 ~ P055

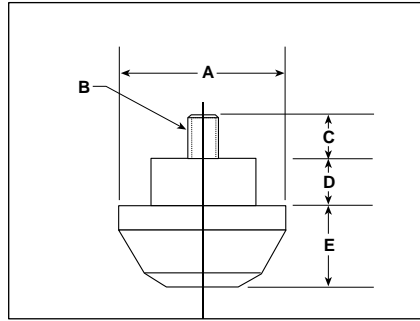

In order to center an Air Picker end-effector and protect the rubber from abrasion during insertion, KOGANEI offers nose cone guides. These nose cones are easily screwed into the metal body.

Applicable Air Picker	Part Number	Former Firestone Part Number	A (in / mm)	B Thread	C (in / mm)	D (in / mm)	E (in / mm)
P010	CRA-108W	WP1-358-1006	0.58 / 14.7	8 - 32 UNC	0.22 / 5.6	0.19 / 4.8	0.50 / 12.7
P014	CRA-109W	WP1-358-1016	0.78 / 19.8	10 - 24 UNC	0.25 / 6.4	0.31 / 7.9	0.55 / 14.0
P017	CRA-110W	WP1-358-1017	0.90 / 22.9	10 - 24 UNC	0.25 / 6.4	0.31 / 7.9	0.55 / 14.0
P019	CRA-111W	WP1-358-1018	1.10 / 27.9	10 - 24 UNC	0.25 / 6.4	0.31 / 7.9	0.55 / 14.0
P022	CRA-112W	WP1-358-1019	1.13 / 28.7	10 - 24 UNC	0.29 / 7.4	0.31 / 7.9	0.55 / 14.0
P025	CRA-113W	WP1-358-1020	1.17 / 29.7	1/4 - 20 UNC	0.29 / 7.4	0.31 / 7.9	0.55 / 14.0
P035	CRA-114W	WP1-358-1021	1.68 / 42.7	1/4 - 20 UNC	0.29 / 7.4	0.31 / 7.9	0.68 / 17.3
P045	CRA-115W	WP1-358-1022	2.03 / 51.6	1/4 - 20 UNC	0.29 / 7.4	0.31 / 7.9	0.68 / 17.3
P055	CRA-116W	WP1-358-1023	2.51 / 63.8	1/4 - 20 UNC	0.29 / 7.4	0.31 / 7.9	0.68 / 17.3

• Metric Air Fittings

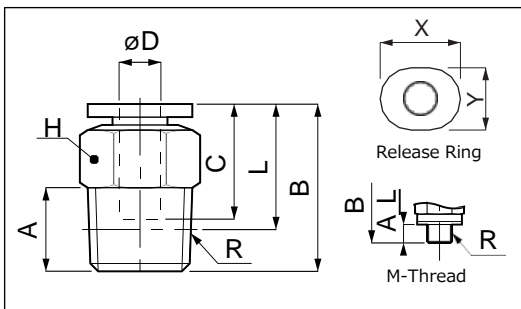

• Metric Port Plugs (see drawings for part numbers)

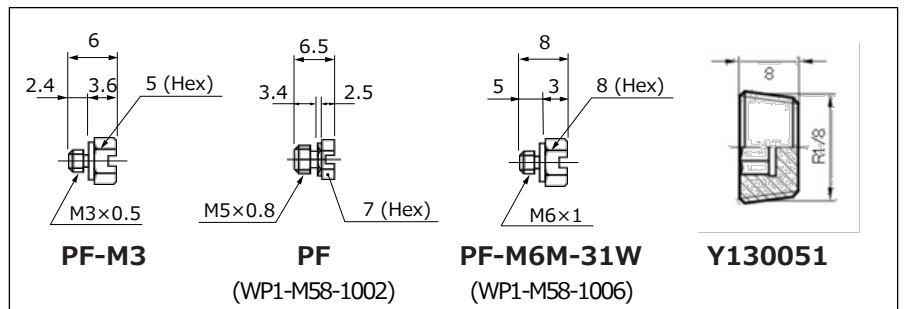

Part Number	Former Firestone Part Number	Tube Size ØD	R	A (mm)	B (mm)	L (mm)	C (mm)	H Hex (mm)	X (mm)	Y (mm)	Effective Area (mm ²)	Weight (g)
PC1/8-M3M	WP1-M58-1001	1/8"	M3 x 0.5	2.5	15.1	12.6	10.9	8	9.8	7.8	0.9	2.5
PC1/8-M5M	WP1-M58-1004	1/8"	M5 x 0.8	3	15.6	12.6	10.9	8	9.8	7.8	2.6	3.5
PC1/8-M6M	WP1-M58-1003	1/8"	M6 x 1.0	3.9	16.6	12.7	10.9	8	9.8	7.8	2.9	3.6
PC1/8-01M	WP1-M58-1005	1/8"	R 1/8	8	15.6	11.6	10.9	10	9.8	7.8	2.7	6.6

Accessories

• Protective Sleeves

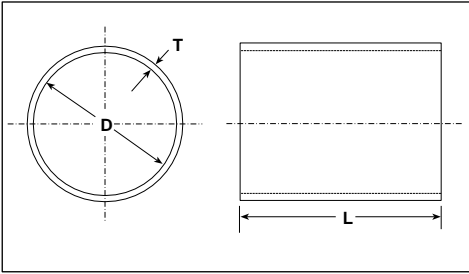

In order to protect the rubber bladder from abrasive surfaces, KOGANEI offers neoprene protective sleeves.

A rubber sleeve is slipped over the deflated bladder with the assistance of air or water as a lubricant. In addition to improving the life in a standard application, the protective sleeve can also provide the needed support when inflating the Air Picker end-effector unrestrained.

The thickness of the protective sleeve will increase the diameter of the rubber bladder as well as restrict its diameter growth during inflation.

Applicable Air Picker	Part Number	Former Firestone Part Number	T (in / mm)	D (in / mm)	L (in / mm)
P014	KUCS1500	WP1-358-1500	0.05 / 1.3	0.7 / 18	1.5 / 38
P017	KUCS1501	WP1-358-1501	0.05 / 1.3	0.8 / 20	1.5 / 38
P019	KUCS1502	WP1-358-1502	0.05 / 1.3	0.9 / 23	1.5 / 38
P022	KUCS1503	WP1-358-1503	0.05 / 1.3	1.0 / 25	1.75 / 44
P025	KUCS1504	WP1-358-1504	0.08 / 2.1	1.1 / 27	2.125 / 54
P035	KUCS1505	WP1-358-1505	0.08 / 2.1	1.5 / 37	2.5 / 64
P045	KUCS1506	WP1-358-1506	0.08 / 2.1	1.9 / 47	2.875 / 73
P055	KUCS1507	WP1-358-1507	0.08 / 2.1	2.2 / 57	3.125 / 79

1

Factors Affecting Durability Life

① **Diameter of the work piece to be held**

Inflating the rubber tube modestly will have a beneficial effect on the life of both AIR PICKER and AIR GRIPPER. If the diameter of the work-piece to be handled extends over the applicable range of two AIR PICKER / AIR GRIPPER models, therefore, it is recommended that the larger size AIR PICKER and the smaller size AIR GRIPPER be selected for use.

The life of AIR PICKER / AIR GRIPPER may vary largely depending on whether the work-piece diameter size corresponds to the maximum or minimum value of the applicable range.

② **Operational air pressure**

To maximize the life, it is recommended to restrict the air pressure to the extent that no abrasion is caused between AIR PICKER / AIR GRIPPER and the work piece being handled.

③ **Remaining air pressure after exhaustion**

The life will be longer if the air pressure put in the rubber tube is not completely exhausted and left inside at the level as the work piece is released.

④ **Surface finish of the work-piece**

The rubber tube of AIR PICKER / AIR GRIPPER inevitably touches with the surface of the work-piece, and the finish condition and smoothness of contact portion of the work-piece will greatly affect the durability life of AIR PICKER / AIR GRIPPER.

⑤ **In using AIR PICKER / AIR GRIPPER, please observe the handling precautions strictly.**

2

Time of Replacement

When the durability life of AIR PICKER / AIR GRIPPER nears its end, the following phenomena will arise. The emergence and extent of such phenomena vary depending on the actual conditions of use. Check AIR PICKER / AIR GRIPPER periodically, therefore, and replace it with a new one immediately if any of the conditions below is found.

- ① Exposed threads due to abrasion of rubber tube (for AIR PICKER)
- ② Breakage of rubber tube found when it is inflated
- ③ Uneven intervals between threads found when rubber tube is inflated (for AIR PICKER)
- ④ Difficulty in setting rubber tube to the work
- ⑤ Slow air exhaustion
- ⑥ Poor inflation of rubber tube

Note: The phenomena 5 and 6 may arise due to clog or air leakage of the piping system. Check the piping system, therefore, when such phenomena are found.

3





Others

- ① Both AIR PICKER and AIR GRIPPER have been certified by Japan Food Hygiene Association as meeting the requirements of its standards for food, additives, etc. and having passed its standard tests and inspections for packaging of instruments or containers.
- ② Please consult us if you intend to use AIR PICKER and AIR GRIPPER for any other purpose than handling work-pieces.

HANDLING PRECAUTIONS

Before selecting a model of AIR PICKER/AIR GRIPPER, and before using it, read this HANDLING PRECAUTIONS carefully for its proper use. They are intended to inform you of the safe and proper operation of your AIR PICKER/AIR GRIPPER, and thereby protect you and other persons against possible danger or loss of property.

The precautions are classified into four categories, namely, "DANGER", "WARNING", "CAUTION" and "BEWARE", according to the extent of possible danger and damage, as follows:

 DANGER	<p>It indicates an imminently hazardous situation which, if not avoided, may result in the user's death or serious injury. Loss of or damage to the property may also be possible.</p>	 CAUTION	<p>It indicates a potentially hazardous situation which, if not avoided, may result in the user's mild or moderate injury. Loss of or damage to the property may also be possible.</p>
 WARNING	<p>It indicates a potentially hazardous situation which, if not avoided, may result in the user's death or serious injury. Loss of or damage to the property may also be possible.</p>	 BEWARE	<p>It indicates the requirements that the user should observe for proper use and handling of your AIR PICKER or AIR GRIPPER, though no hazardous situation causing injury or property loss is involved.</p>

■ AIR PICKER/AIR GRIPPER is designed and manufactured for use as general industrial equipment parts.

■ Before selecting a model of AIR PICKER/AIR GRIPPER, and before using it, read the "HANDLING PRECAUTIONS", "CATALOGUE", etc. carefully for its proper use.

DANGER

- Do not use AIR PICKER /AIR GRIPPER for the following purposes:
 1. use as medical equipment intended for maintaining and controlling of human life and physical condition;
 2. use as a mechanism or equipment intended for moving or transporting human beings; and
 3. use as safety parts integral to a machine.

AIR PICKER/AIR GRIPPER is not designed for purposes that require high levels of safety. Such use may damage human life.
- While AIR PICKER/AIR GRIPPER is in operation, do not touch it or bring yourself near to it. It may move unexpectedly to cause an injury.
- When installing AIR PICKER/AIR GRIPPER, be sure to mount and fix it securely so that it can withstand the load of the work it holds.

Otherwise, it may fall down, drop or malfunction to cause an injury.

- Never tamper with AIR PICKER/AIR GRIPPER, as it may malfunction to cause an injury.
- Do not disassemble AIR PICKER/AIR GRIPPER to alter its fundamental structure, performance or function, as this may cause an injury.
- Do not expose AIR PICKER/AIR GRIPPER to splashes of water. Exposing it to water, or cleaning it or using it in water may cause an injury due to malfunction.

WARNING

- AIR PICKER/AIR GRIPPER is a consumable, and replace it with a new one immediately if you noticed any phenomena indicating the time of replacement (see "DURABILITY LIFE OF AIR PICKER/AIR GRIPPER"). The damaged rubber tube may cause an injury.
- Do not use AIR PICKER/AIR GRIPPER for the purpose of absorbing the shocks and vibrations generated by the machine to which it is mounted. It may be broken to cause an injury, or damage the machine.
- Before supplying air into the rubber tube of AIR PICKER/AIR GRIPPER, and before starting its operation, be sure to check the moving

range of the machine for safety's sake.

Otherwise, the moving portion of the machine may touch you to cause an injury.

- Do not put AIR PICKER/AIR GRIPPER into fire, as this may explode it or cause it to generate a poisonous gas.
- Before performing such work as maintenance, checking, overhauling and replacement, be sure to completely cut off the air supply, and check that the air pressure inside AIR PICKER/AIR GRIPPER and the connected pipes has reached "0". If the air remains inside the air compressor or air storage tank, in particular, AIR PICKER/AIR GRIPPER may move unexpectedly to cause an injury.

BEWARE

- If you consider using AIR PICKER/AIR GRIPPER under any condition or in any environment that is not specified in the "CATALOGUE", or using it for purposes that may affect the human life and property and thus require high levels of safety, such as the use with aeronautical instruments, combustion equipment, recreational machine, and safety device, use it well within the rating and performance range, and take such safety measures as a failsafe device. Also, be sure to consult our salesperson in charge for further information.
- Establish a control system that prevents the work from dropping in case of power failure or emergency stop of the machine.
- Do not use AIR PICKER/AIR GRIPPER at places where it is exposed to direct sunlight (ultraviolet rays), dust, salt or iron, or in the atmospheres that contain phosphate operating oil, mineral oil, sulfur dioxide

gas, chlorinated gas, acids, etc. Otherwise, this will cause a temporary function failure, abrupt performance degradation, or shortening of the durability life.

- To install piping, refer to the "CATALOGUE", etc.
- When handling AIR PICKER/AIR GRIPPER, wear hand-protection gloves, eye-protection glasses or safety shoes as required, to secure safety.
- When AIR PICKER/AIR GRIPPER becomes inoperable or unnecessary, dispose of it as industrial waste according to the regulations of the authority concerned.

OTHERS

- Be sure to observe the above precautions strictly. BRIDGESTONE will not take any responsibility for any accident or damage caused by failure to observe any of them.

HANDLING INSTRUCTIONS AND PRECAUTIONS

AIR PICKER

1. Before use, check the rubber tube for scratches.
2. Do not bring the rubber tube in contact with anything that has a sharp tip or edge, and do not apply undue shock to it.
3. Before using AIR PICKER for the first time after it was purchased or after it has been left unused for a long time, supply and exhaust air several times to warm up the rubber tube.
4. Do not leave AIR PICKER untouched for a long time with the rubber tube filled with air.
5. Do not store AIR PICKER at places where it is exposed to direct sunlight or humidity.
6. Do not inflate the rubber tube frequently without holding the work, as this will accelerate its durability life.
7. As AIR PICKER is a consumable, replace it with a new one immediately when you have noticed any phenomena indicating deterioration.
8. While AIR PICKER is holding the work, make sure that no substance that could reduce friction such as oil and water gets in between the rubber tube and the work, as this will decrease the AIR PICKER's strength to hold the work sharply.
9. To supply air, be sure to let it in through the pressure reducing valve and the filter oil elimination filter, while keeping it below the maximum operational air pressure. Unduly high pressure air or air containing oil or water will shorten the durability life of AIR PICKER.
10. Using AIR PICKER with the work having inside diameter beyond its applicable range will accelerate its durability life.
11. Do not tamper with the body of AIR PICKER, as this may damage the rubber tube to accelerate its durability life.
12. Use a screw and sealant to plug the female screw portion that is unused as an air inlet/outlet.

AIR GRIPPER

1. Before use, check the rubber tube for scratches.
2. Do not bring the rubber tube in contact with anything that has a sharp tip or edge, and do not apply undue shock to it.
3. Before using AIR GRIPPER for the first time after it was purchased or after it has been left unused for a long time, supply and exhaust air several times to warm up the rubber tube.
4. Do not leave AIR GRIPPER untouched for a long time with the rubber tube filled with air.
5. Do not store AIR GRIPPER at places where it is exposed to direct sunlight or humidity.
6. Do not inflate the rubber tube frequently without holding the work, as this will accelerate its durability life.
7. As AIR GRIPPER is a consumable, replace it with a new one immediately when you have noticed any phenomena indicating deterioration.
8. While AIR GRIPPER is holding the work, make sure that no substance that could reduce friction such as oil and water gets in between the rubber tube and the work, as this will decrease the AIR GRIPPER's strength to hold the work sharply.
9. To supply air, be sure to let it in through the pressure reducing valve and the filter oil elimination filter, while keeping it below the maximum operational air pressure. Unduly high pressure air or air containing oil or water will shorten the durability life of AIR GRIPPER.
10. Do not tamper with the body of AIR GRIPPER, as this may damage the rubber tube to accelerate its durability life.

- The specifications are subject to change without prior notice for product improvement.
- As of October 2021

BRIDGESTONE CORPORATION

Yaesu Center Bldg. 10F, 1-6-6, Yaesu,
Chuo-ku, Tokyo 103-0028, Japan
Phone: +81 3-5202-6853
Fax : +81 3-5202-6856



KOGANEI
International America, Inc.

48860 Milmont Drive, Fremont, CA 94538 USA
Phone: 1-855-564-2634 Email: sales@koganeiusa.com