

Safe. Efficient. Strong.



Auto Leveling Pallet Forks

Save time and money with the MBRA-E Auto Leveling Pallet Forks from Boscaro.

Lift safely and efficiently with these versatile pallet forks. An internal spring system automatically levels your load to the most neutral position, and the adjustable verticle riser and tines ensure that no load is too big or too small to handle.

All Boscaro below-the-hook accessories are certified for use across North America and meet or exceed **ASME B-TH1/B30.20** standards.

Each unit comes with a dedicated serial number and conformity statement which ensures compliance with ASME.



FEATURES

- Automatic load leveling
- Telescopic vertical riser and adjustable sliding forks
- Lightweight to maximize lift capacity
- Durable powder coated finish
- Meets or exceeds all ASME Standards



"The best money we've ever spent on crane accessories."

MIKE DAWSON, President
Big Red Crane Company, Inc.



Supply & Service
Across North America

www.bigfootcrane.com
1-855-598-3915

Safe. Efficient. Strong.

Auto Leveling Pallet Forks

MBRA-E Series

“Boscaro products have proven time and time again their quality, safety, and durability. Boscaro products continue to offer significant value on our projects.”

ED HAWTHORNE-SAFETY MANAGER
Walsh/PCL- JV II

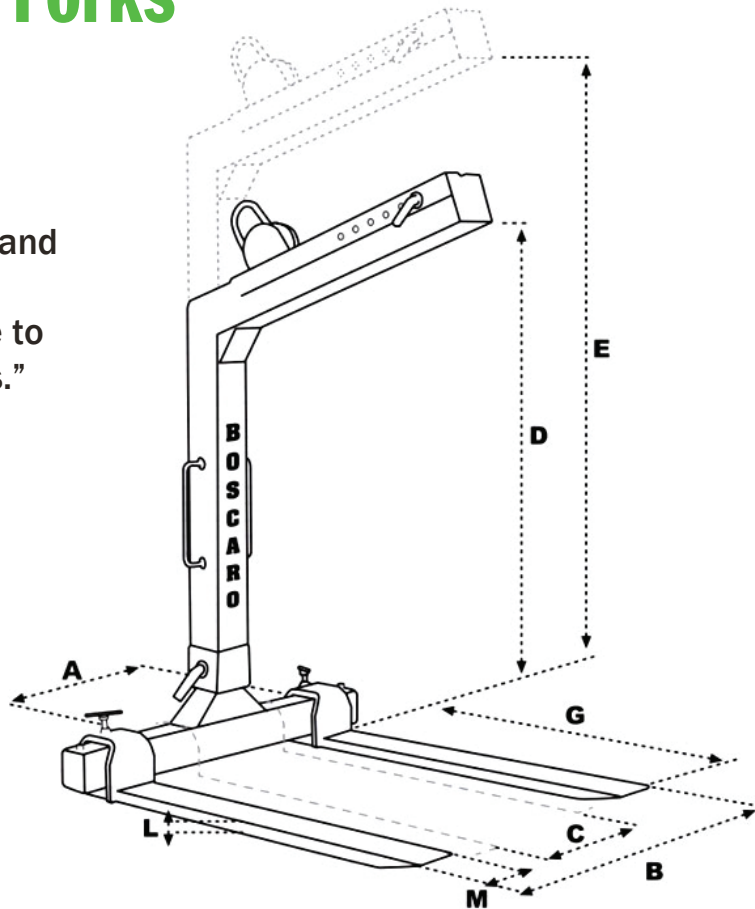

SPECIFICATIONS

Model	Capacity	A	B	C	D	E	G	L	M	Weight
MBRA-15E-12*	3,300 lb	3'1"	3'3"	1'4"	5'0"	6'9"	4'0"	1.3"	4"	410 lb
MBRA-20E-12*	4,400 lb	3'1"	3'3"	1'4"	5'0"	6'9"	4'0"	1.3"	4.7"	440 lb
MBRA-25E-12	5,500 lb	3'1"	3'3"	1'4"	3'6"	5'4"	4'0"	1.4"	4.7"	575 lb
MBRA-30E-12	6,613 lb	3'1"	3'3"	1'4"	3'6"	5'4"	4'0"	1.4"	4.7"	675 lb

*3'3" Fork length models also available



Bigfoot Crane Company Inc. supplies and services Boscaro equipment across North America.

www.bigfootcrane.com

Call Toll Free
1-855-598-3915

Talk To An Expert