

Economic Style Electric Actuator ITQ Series



INNOBIZ
기술혁신형중소기업



ECONOMIC TYPE ITQ ELECTRIC ACTUATOR

ITQ 0020

- Suitable for small 1" ball valve automation.
- Very high efficiency & cyclic life.
- Free voltage (87~270 VAC, 1Phase) and optional 24V AC/DC
- Very compact and light weight.



PG11 Cable Gland with Wires



ISO F03 Flange

11X11mm
Square Female Shaft
with insert 9X9mm

PERFORMANCE

Model	Rate torque (Nm)	Duty cycle (%)	Operating time 50Hz /60Hz	Stem Adaption (Square Female shaft) 11 X 11 mm	Rated current				Motor insulation class	Weight (kgs)
					24V		1Phase			
					AC	DC	110	220		
ITQ 0020	25	50	11	11 X 11 mm	0.60	0.55	0.16	0.08	E	1

STANDARD SPECIFICATION

Enclosure	IP66, O-ring Sealed
Main Power	Free Voltage (110/220VAC/1Ph/50/60Hz) 24V AC/DC
Duty cycle(on-off)	S2 : 50%
Motor	DC motor
Limit switches	2 ea for Open & Close (5A, 250VAC)
Extra Limit switches	Relays for Open & Close (5A, 250VAC)
Mounting	ISO F03, 11 X 11 - DP12 Square female Shaft with insert 9X9mm
Travel angle	90°C ± 5°C
Cable entry & Wiring	1-PG11 Cable gland with wires 30cm long
Surface protection	Polyester coating
Ambient temperature	-10°C ~ + 65°C
Humidity(R.H)	90%

WIRING ITQ 0020 free voltage (110/220VAC)

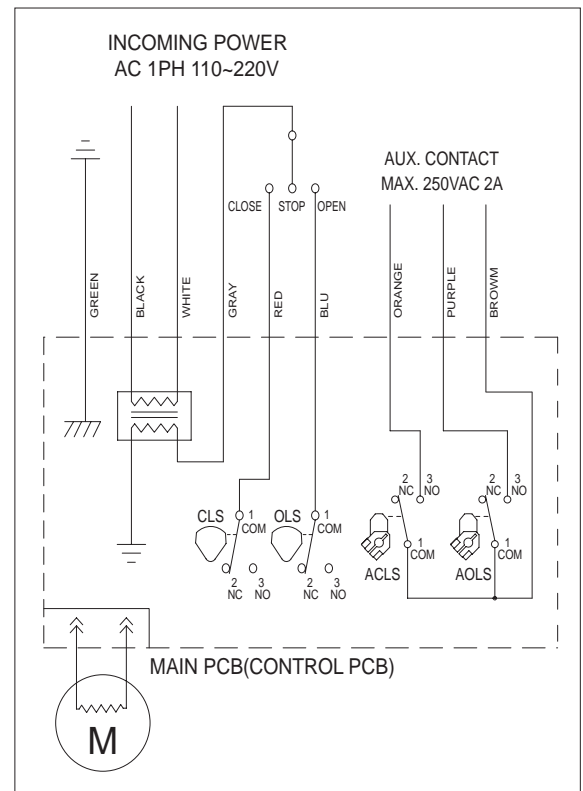

ITQ 0040

- Suitable for on-off small ball /plug valves and damper automation.
- By combination of spur gears, provide very high efficiency
- The motor is a specially designed induction motor that produces high starting torques and thermally protected from overheating.
- Manual operation by Spanner and dial position indication
- Compact and light weight.
- High duty cycle.

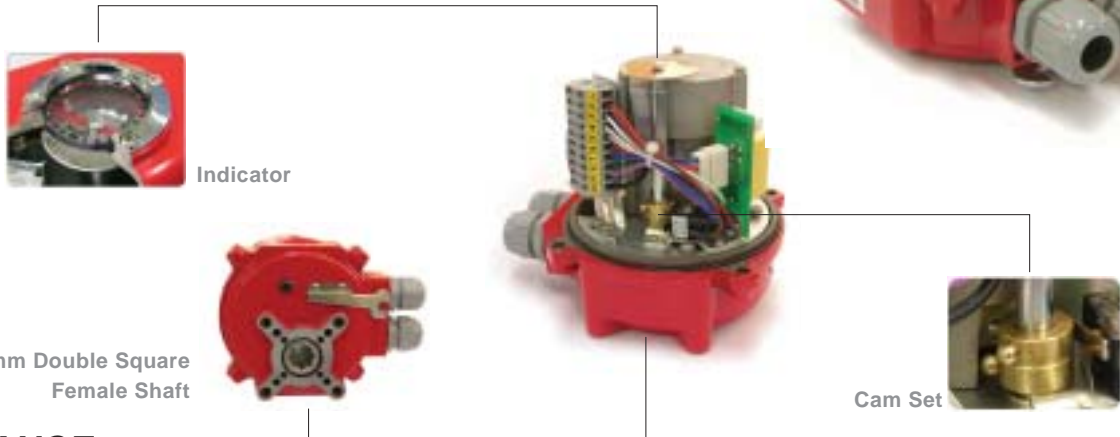

PERFORMANCE

Model	Rate torque (Nm)	Duty cycle (%)	Operating time		Stem Adaption (Double square Female shaft)	Rated current					Motor insulation class	Weight (kgs)	No of handwheel turn
			50Hz	60Hz		1Phase		3Phase		DC			
						110	220	380	440				
ITQ 0040	40	50	14	12	14X14mm	0.27	0.18	N/A	N/A	0.8	E	3	7.5

STANDARD SPECIFICATION

Enclosure	IP66, O-ring Sealed
Main Power	110/220VAC/1Ph/50/60Hz, 24V DC
Control power	110/220VAC/1Ph/50/60Hz
Duty cycle(on-off)	S2 : 50%, max 30minutes
Motor	Induction motor
Limit switches	2 ea for each travel (No extra switch)
Space heater	2W
Manual operation	Extruded shaft on bottom
Indicator	Continous Mechanical position indicator
Mounting	ISO F03/F05/07 flange with double square female shaft
Travel angle	90° ± 10°
Cable entries	2 - PG 13.5
Terminal block	Spring loaded push type
Surface protection	Anodized polyester coating
Ambient temperature	-20°C~+70°C
Humidity(R.H)	90%

WIRING

ITQ 0040 110/220 ON/OFF

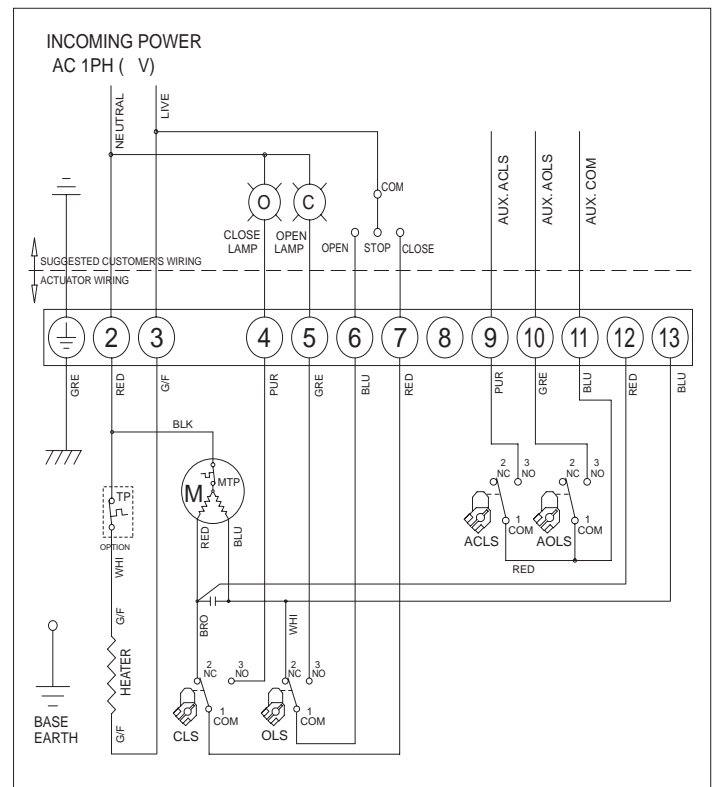

ECONOMIC TYPE ITQ ELECTRIC ACTUATOR

ITQ 0080



- Newly designed and developed for especially small ball & plug valves and damper automation.
- Self locking combination of spur and worm gears that require no brake
- The motor is a specially designed induction motor that produces high starting torques and thermally protected from overheating
- Mechanical Stopper bolts to prevent from over travel
- Easy set cams without special tool.
- Manual operation by wrench directly to the worm gearbox and dial position indication

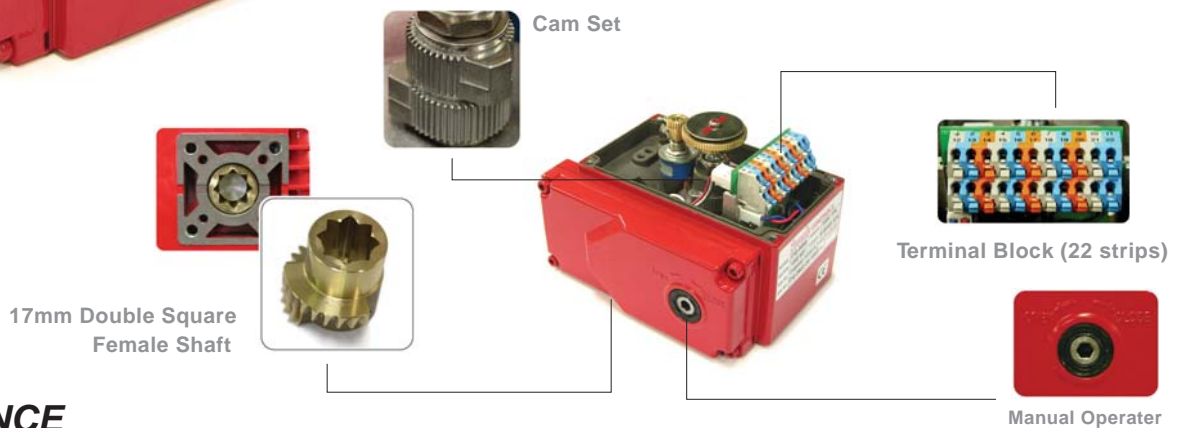

PERFORMANCE

Model	Rate torque (Nm)	Duty cycle (%)	Operating time		Adaption (Double square Female shaft)	Rated current					Motor insulation class	Weight (kgs)	No of handwheel turn
			50Hz	60Hz		1Phase		3Phase		DC			
						110	220	380	440				
ITQ 0080	80	50	16	14	17X17mm	0.97	0.52	0.52	0.56	0.8	E	3.5	7

STANDARD SPECIFICATION

Enclosure	Weatherproof IP67, O-ring sealed
Main Power	110/220VAC/1Ph/50/60Hz, 380/440VAC/3Ph/50/60/Hz,24VDC
Control power	110/220VAC/1Ph/50/60Hz
Duty cycle(on-off)	S2 : 40%, Max 30 minutes
Motor	S4, 50%, 1200 start/Hour
Duty cycle(modulating)	Induction motor
Limit switches	2 ea for each travel end (1 each as dry contact)
Space heater	3W
Manual operation	By wrench (M6) directly to the worm gear
Indicator	Continous Mechanical position indicator
Mounting	ISO F05 & F07 flange with double square female shaft
Self locking	By means of worm gearing
Travel angle	90° ± 10° by external adjustable mechanical stopper
Cable entries	2 - M20 X 1.5 (option : 2- PF1/2")
Terminal block	Spring loaded push type
Surface protection	Anodized & polyester coating
Ambient temperature	-20°C~+70°C
Humidity(R.H)	90%

OPTION AVAILABLE (0080 Only)

PK	-Potentiometer kit (output signal : 0~1 Kohm)
	-High resolution potentiometer
CT	-Current transmitter (output signal : 4-20mA)
	-Zero / Span Adjustment
	-Convertible DIP Switch (4 wire to 2 wire)
RPC	-Remote position controller (by input and output signal)
	-Input : 4-20mA, 0-10VDC, 2~10VDC, 1~5VDC, 0~5VDC
	-Output : 4-20mA, 0-10VDC, 2~10VDC, 1~5VDC, 0~5VDC
	-Auto-calibration
	-Reverse operating direction

DIMENSIONAL DRAWING

ITQ 0020

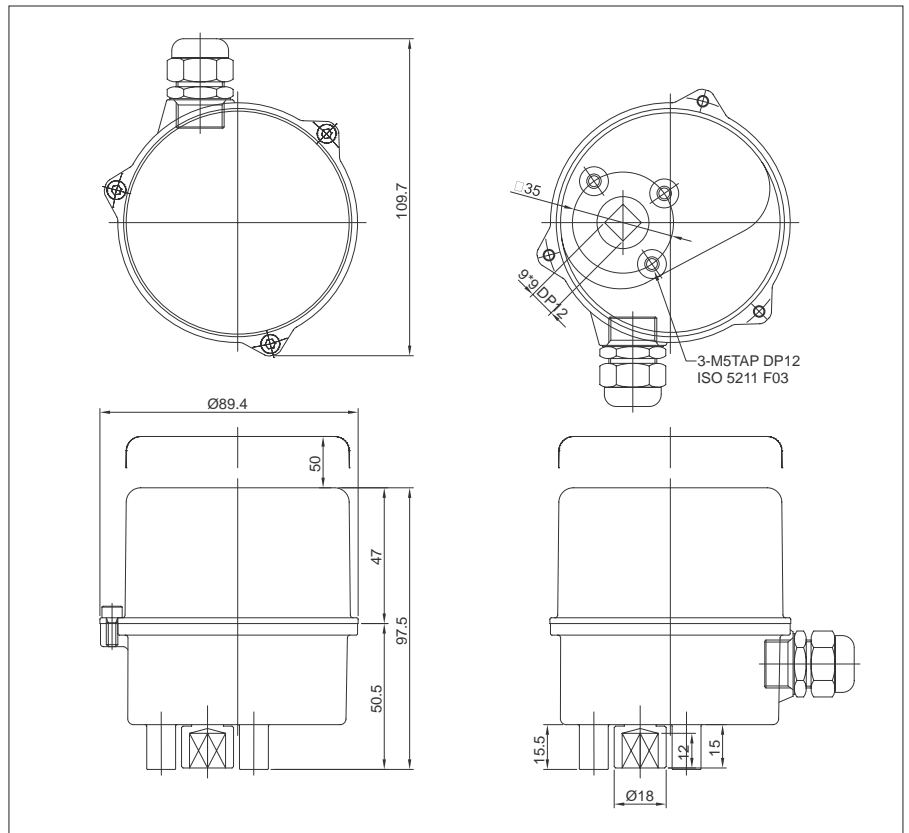

ITQ 0040

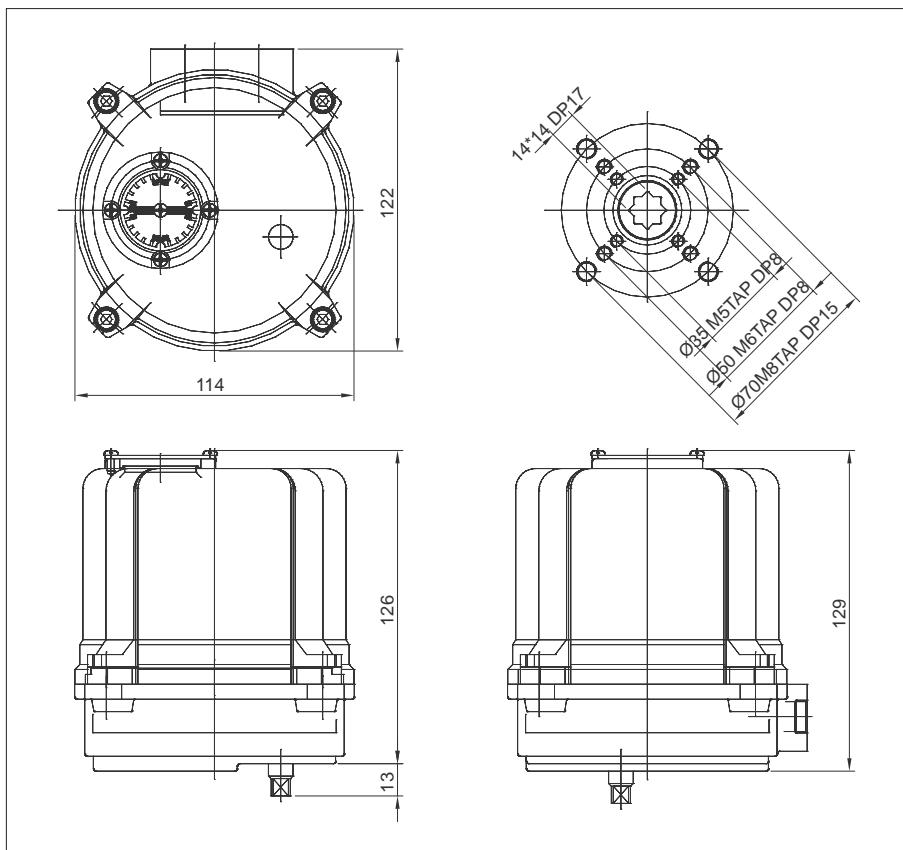

ECONOMIC TYPE ITQ ELECTRIC ACTUATOR

DIMENSIONAL DRAWING

ITQ 0080

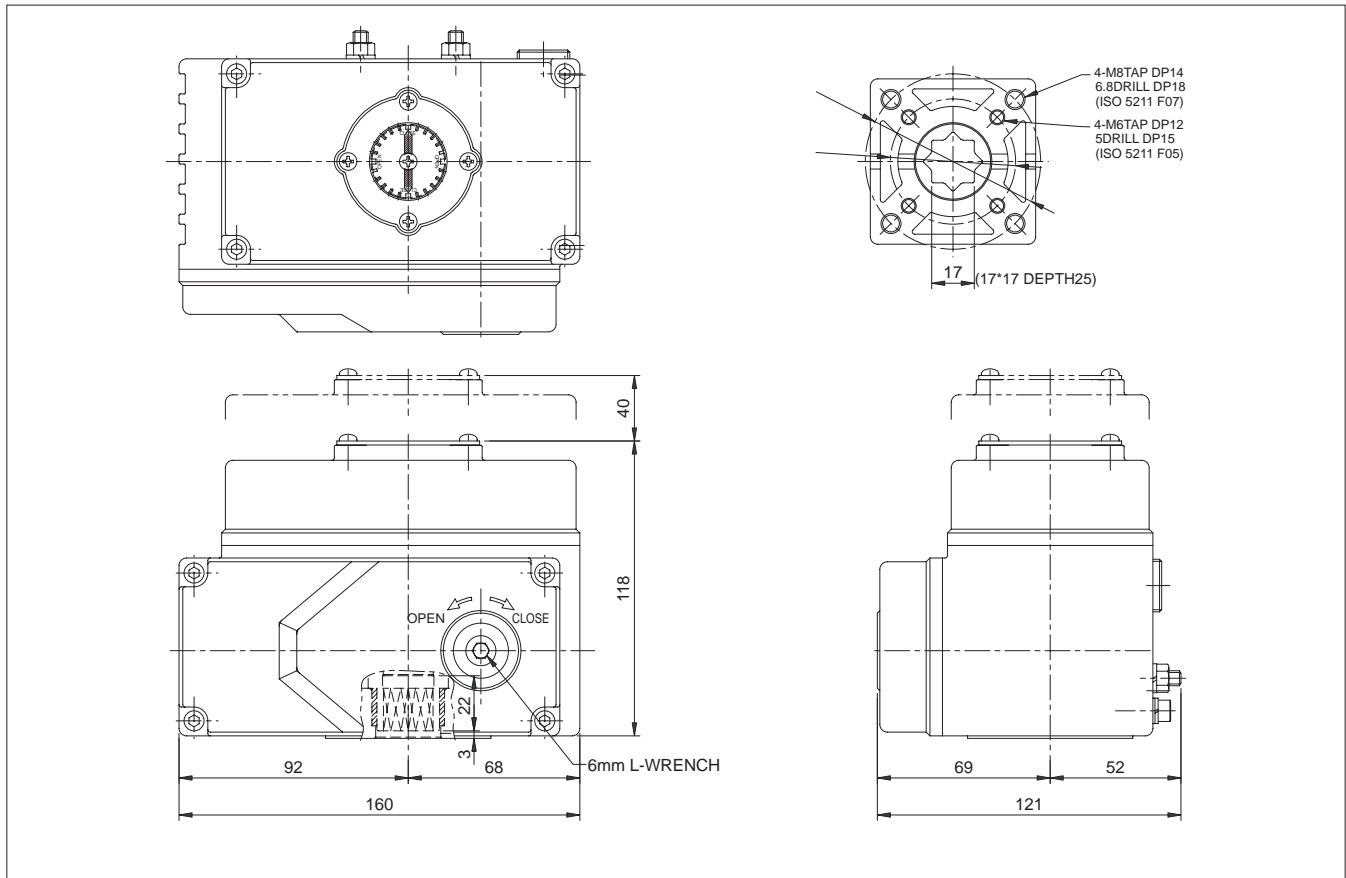

WIRING

ITQ 0080 110/220 (On-Off)

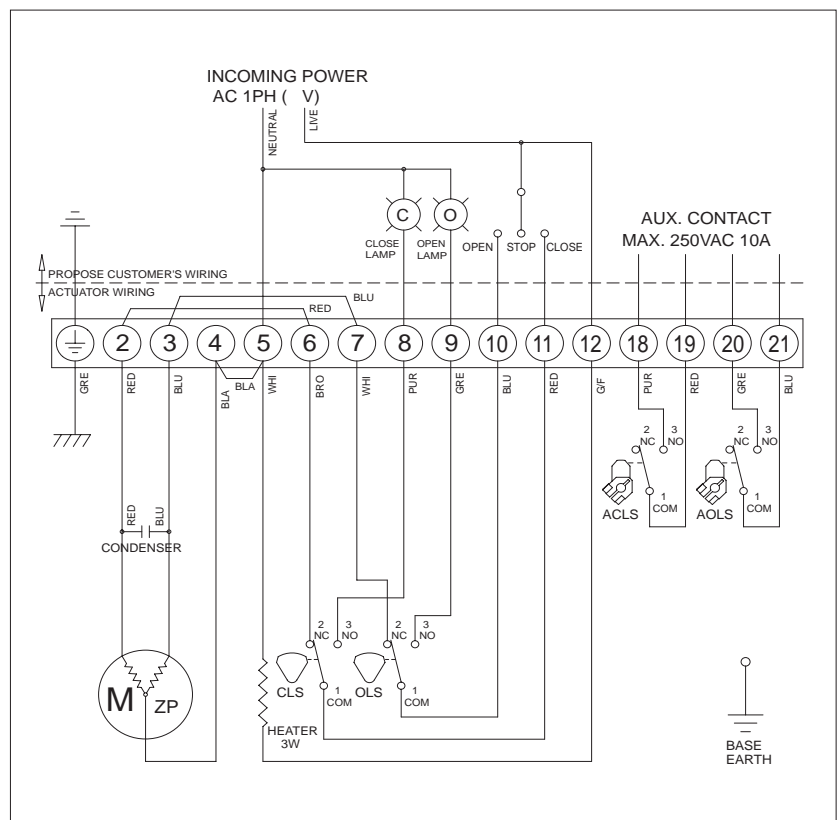

WIRING

ITQ 0080 380/440 ON/OFF

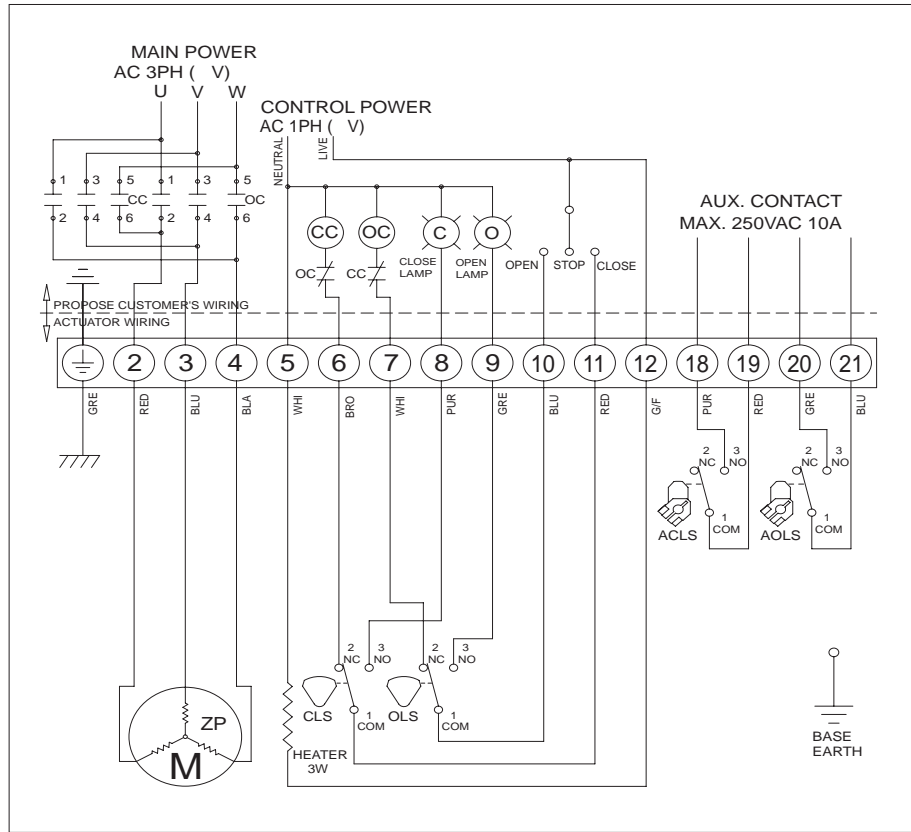

ITQ 0080 110/220 RPC

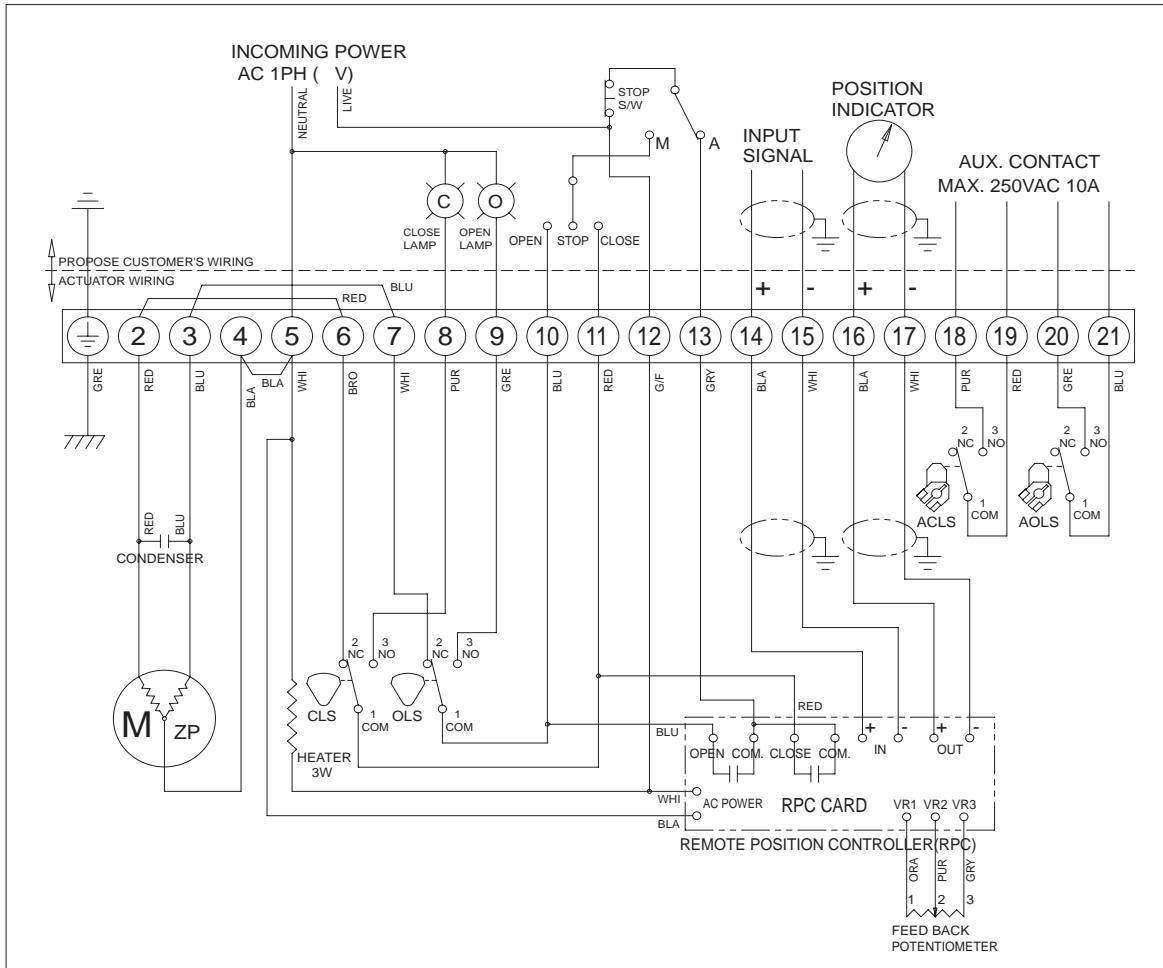



The details of this catalog are subject to change without prior notification.

i-tork[®] CONTROLS Co., Ltd.

Website : <http://www.i-tork.com>