

Reactor® E-30i and E-XP2i

3A1705J
EN

Electric, Heated, Integrated Plural Component Proportioning System With Integrated Generator. For spraying polyurethane foam and polyurea coatings. For professional use only. Not approved for use in explosive atmospheres or hazardous locations.



Important Safety Instructions

Read all warnings and instructions in this manual. **Save these instructions.**

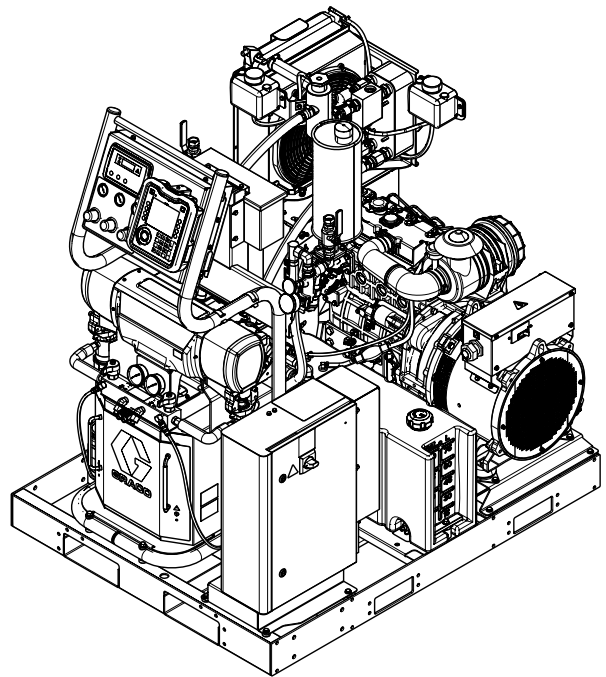

















Contents





Warnings	3	Advanced Setup Screens	46
Important Two-Component Material Information	7	System	47
Proportioner Models	9	Recipes	47
Systems	10	Run Mode	48
Accessories	11	Startup	55
Supplied Manuals	12	Temporary Manual Hose Temperature Control	58
Related Manuals	12	Fluid Circulation	59
Typical Installation, with circulation	13	Circulation Through Reactor	59
Typical Installation, without circulation	14	Circulation Through Gun Manifold	60
Component Identification	15	Jog Mode	60
Generator	17	Spraying	61
Proportioner Control Panel	18	Spray Adjustments	62
Air Compressor	18	Shutdown	63
Advanced Display Module (ADM)	19	Pressure Relief Procedure	64
Motor Control Module (MCM)	23	Flushing	65
Engine Control Module	24	Maintenance	66
Load Center	25	Preventative Maintenance Schedule	66
Temperature Control Modules	26	Proportioner Maintenance	66
Circuit Breakers	28	Engine Maintenance	67
Overview	30	Fuel Tank	67
Setup	33	Flush Inlet Strainer Screen	67
Locate Reactor	33	Pump Lubrication System	68
Trailer Setup Guidelines	35	Drain Coolant	69
Install Wall (optional)	36	Refill Proportioner Coolant Loop	70
Connect Battery	38	Refill Engine Coolant Loop	72
Add Fuel	38	Coolant Specifications	72
General Equipment Guidelines	38	Errors	73
Electrical Connections	39	View Errors	73
Connect Feed Pumps	39	Troubleshoot Errors	73
Breathing Air	39	Troubleshooting	74
Connect Pressure Relief Lines	40	Error Codes and Troubleshooting	74
Install Fluid Temperature Sensor	40	USB Data	89
Connect Heated Hose	40	USB Logs	89
Close gun fluid manifold valves A and B	41	System Configuration Settings	90
Connect Whip Hose to Gun Or Gun Fluid Manifold	41	Download Procedure	91
Pressure Check Hose	41	Custom Language File	91
Connect Remote Display Module	41	Upload Procedure	92
Grounding	41	Appendix A: Engine Control Module	93
Supply Wet Cups With Throat Seal Liquid (TSL)	42	Dimensions	96
Advanced Display Module (ADM) Operation	43	Performance Charts	99
		Technical Specifications	102
		Graco Standard Warranty	106







Warnings

The following warnings are for the setup, use, grounding, maintenance and repair of this equipment. The exclamation point symbol alerts you to a general warning and the hazard symbol refers to procedure-specific risks. When these symbols appear in the body of this manual refer back to these Warnings. Product-specific hazard symbols and warnings not covered in this section may appear throughout the body of this manual where applicable.

 WARNING	
	<p>ELECTRIC SHOCK HAZARD</p> <p>This equipment must be grounded. Improper grounding, setup, or usage of the system can cause electric shock.</p> <ul style="list-style-type: none"> • Turn off and disconnect power at main switch before disconnecting any cables and before servicing equipment. • Connect only to grounded power source. • All electrical wiring must be done by a qualified electrician and comply with all local codes and regulations.
	<p>TOXIC FLUID OR FUMES</p> <p>Toxic fluids or fumes can cause serious injury or death if splashed in the eyes or on skin, inhaled, or swallowed.</p> <ul style="list-style-type: none"> • Read MSDSs to know the specific hazards of the fluids you are using. • Store hazardous fluid in approved containers, and dispose of it according to applicable guidelines.
	<p>CARBON MONOXIDE HAZARD</p> <p>Exhaust contains poisonous carbon monoxide, which is colorless and odorless. Breathing carbon monoxide can cause death.</p> <ul style="list-style-type: none"> • Do not operate in an enclosed area.
	<p>PERSONAL PROTECTIVE EQUIPMENT</p> <p>You must wear appropriate protective equipment when operating, servicing, or when in the operating area of the equipment to help protect you from serious injury, including eye injury, hearing loss, inhalation of toxic fumes, and burns. This equipment includes but is not limited to:</p> <ul style="list-style-type: none"> • Protective eyewear, and hearing protection. • Respirators, protective clothing, and gloves as recommended by the fluid and solvent manufacturer.

 <h1 style="margin: 0;">WARNING</h1>	
  	<p>SKIN INJECTION HAZARD</p> <p>High-pressure fluid from dispensing device, hose leaks, or ruptured components will pierce skin. This may look like just a cut, but it is a serious injury that can result in amputation. Get immediate surgical treatment.</p> <ul style="list-style-type: none"> • Engage trigger lock when not dispensing. • Do not point dispensing device at anyone or at any part of the body. • Do not put your hand over the fluid outlet. • Do not stop or deflect leaks with your hand, body, glove, or rag. • Follow the Pressure Relief Procedure when you stop dispensing and before cleaning, checking, or servicing equipment. • Tighten all fluid connections before operating the equipment. • Check hoses and couplings daily. Replace worn or damaged parts immediately.
   	<p>FIRE AND EXPLOSION HAZARD</p> <p>Flammable fumes, such as solvent and paint fumes, in work area can ignite or explode. To help prevent fire and explosion:</p> <ul style="list-style-type: none"> • Use equipment only in well ventilated area. • Do not fill fuel tank while engine is running or hot; shut off engine and let it cool. Fuel is flammable and can ignite or explode if spilled on hot surface. • Eliminate all ignition sources; such as pilot lights, cigarettes, portable electric lamps, and plastic drop cloths (potential static arc). • Keep work area free of debris, including solvent, rags and gasoline. • Do not plug or unplug power cords, or turn light switches on or off when flammable fumes are present. • Ground all equipment in the work area. See Grounding instructions. • Use only grounded hoses. • Hold gun firmly to side of grounded pail when triggering into pail. • If there is static sparking or you feel a shock, stop operation immediately. Do not use equipment until you identify and correct the problem. • Keep a working fire extinguisher in the work area.
  	<p>THERMAL EXPANSION HAZARD</p> <p>Fluids subjected to heat in confined spaces, including hoses, can create a rapid rise in pressure due to the thermal expansion. Over-pressurization can result in equipment rupture and serious injury.</p> <ul style="list-style-type: none"> • Open a valve to relieve the fluid expansion during heating. • Replace hoses proactively at regular intervals based on your operating conditions.

 <h1 style="margin: 0;">WARNING</h1>	
	<p>PRESSURIZED ALUMINUM HAZARD</p> <p>Use of fluids that are incompatible with aluminum in pressurized equipment can cause serious chemical reaction and equipment rupture. Failure to follow this warning can result in death, serious injury, or property damage.</p> <ul style="list-style-type: none"> • Do not use 1,1,1-trichloroethane, methylene chloride, other halogenated hydrocarbon solvents or fluids containing such solvents. • Many other fluids may contain chemicals that can react with aluminum. Contact your material supplier for compatibility.
	<p>PLASTIC PARTS CLEANING SOLVENT HAZARD</p> <p>Many solvents can degrade plastic parts and cause them to fail, which could cause serious injury or property damage.</p> <ul style="list-style-type: none"> • Use only compatible water-based solvents to clean plastic structural or pressure-containing parts. • See Technical Data in this and all other equipment instruction manuals. Read fluid and solvent manufacturer's MSDSs and recommendations.
 	<p>EQUIPMENT MISUSE HAZARD</p> <p>Misuse can cause death or serious injury.</p> <ul style="list-style-type: none"> • Do not operate the unit when fatigued or under the influence of drugs or alcohol. • Do not exceed the maximum working pressure or temperature rating of the lowest rated system component. See Technical Data in all equipment manuals. • Use fluids and solvents that are compatible with equipment wetted parts. See Technical Data in all equipment manuals. Read fluid and solvent manufacturer's warnings. For complete information about your material, request MSDS from distributor or retailer. • Do not leave the work area while equipment is energized or under pressure. Turn off all equipment and follow the Pressure Relief Procedure when equipment is not in use. • Check equipment daily. Repair or replace worn or damaged parts immediately with genuine manufacturer's replacement parts only. • Do not alter or modify equipment. • Use equipment only for its intended purpose. Call your distributor for information. • Route hoses and cables away from traffic areas, sharp edges, moving parts, and hot surfaces. • Do not kink or over bend hoses or use hoses to pull equipment. • Keep children and animals away from work area. • Comply with all applicable safety regulations.

 <h1 style="margin: 0;">WARNING</h1>	
	<p>BATTERY HAZARD</p> <p>The battery may leak, explode, cause burns, or cause an explosion if mishandled.</p> <ul style="list-style-type: none"> • Only use the battery type specified for use with the equipment. See Technical Data. • Battery maintenance must only be performed or supervised by personnel knowledgeable of batteries and the required precautions. Keep unauthorized personnel away from battery. • When replacing the battery, use the same lead-acid automotive battery, with 800 CCA minimum, specified for use with the equipment. See Technical Data. • Do not dispose of battery in fire. The battery is capable of exploding. • Follow local ordinances and/or regulations for disposal. • Do not open or mutilate the battery. Released electrolyte has been known to be harmful to the skin and eyes and to be toxic. • Remove watches, rings, or other metal objects. • Only use tools with insulated handles. Do not lay tools or metal parts on top of battery.
 	<p>MOVING PARTS HAZARD</p> <p>Moving parts can pinch, cut or amputate fingers and other body parts.</p> <ul style="list-style-type: none"> • Keep clear of moving parts. • Do not operate equipment with protective guards or covers removed. • Pressurized equipment can start without warning. Before checking, moving, or servicing equipment, follow the Pressure Relief Procedure and disconnect all power sources.
	<p>ENTANGLEMENT HAZARD</p> <p>Rotating parts can cause serious injury.</p> <ul style="list-style-type: none"> • Keep clear of moving parts. • Do not operate equipment with protective guards or covers removed. • Do not wear loose clothing, jewelry or long hair while operating equipment. • Equipment can start without warning. Before checking, moving, or servicing equipment, follow the Pressure Relief Procedure and disconnect all power sources.
	<p>BURN HAZARD</p> <p>Equipment surfaces and fluid that's heated can become very hot during operation. To avoid severe burns:</p> <ul style="list-style-type: none"> • Do not touch hot fluid or equipment.

Important Two-Component Material Information

Isocyanate Conditions

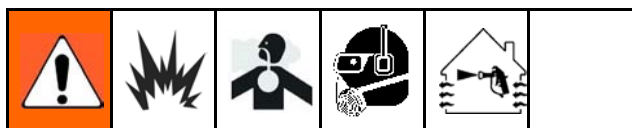

Spraying or dispensing materials containing isocyanates creates potentially harmful mists, vapors, and atomized particulates.

Read material manufacturer's warnings and material MSDS to know specific hazards and precautions related to isocyanates.

Prevent inhalation of isocyanate mists, vapors, and atomized particulates by providing sufficient ventilation in the work area. If sufficient ventilation is not available, a supplied-air respirator is required for everyone in the work area.

To prevent contact with isocyanates, appropriate personal protective equipment, including chemically impermeable gloves, boots, aprons, and goggles, is also required for everyone in the work area.

Moisture Sensitivity of Isocyanates

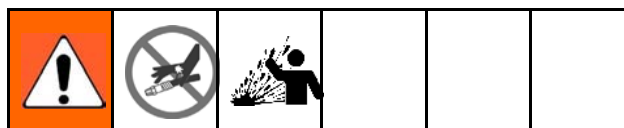

Cross-contamination can result in cured material in fluid lines which could cause serious injury or damage equipment. To prevent cross-contamination of the equipment's wetted parts, **never** interchange component A (isocyanate) and component B (resin) parts.

Isocyanates (ISO) are catalysts used in two component foam and polyurea coatings. ISO will react with moisture (such as humidity) to form small, hard, abrasive crystals, which become suspended in the fluid. Eventually a film will form on the surface and the ISO will begin to gel, increasing in viscosity. If used, this partially cured ISO will reduce performance and the life of all wetted parts.

The amount of film formation and rate of crystallization varies depending on the blend of ISO, the humidity, and the temperature.

To prevent exposing ISO to moisture:

- Always use a sealed container with a desiccant dryer in the vent, or a nitrogen atmosphere. **Never** store ISO in an open container.
- Keep the ISO lube pump reservoir (if installed) filled with appropriate lubricant. The lubricant creates a barrier between the ISO and the atmosphere.
- Use only moisture-proof hoses compatible with ISO.
- Never use reclaimed solvents, which may contain moisture. Always keep solvent containers closed when not in use.
- Always lubricate threaded parts with ISO pump oil or grease when reassembling.

Material Self-Ignition

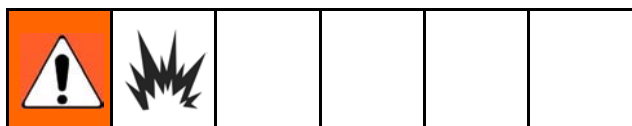

Some materials may become self-igniting if applied too thickly. Read material manufacturer's warnings and material MSDS.

Keep Components A and B Separate



Cross-contamination can result in cured material in fluid lines which could cause serious injury or damage equipment. To prevent cross-contamination of the equipment's wetted parts, **never** interchange component A (isocyanate) and component B (resin) parts.

Foam Resins with 245 fa Blowing Agents

Some foam blowing agents will froth at temperatures above 90°F (33°C) when not under pressure, especially if agitated. To reduce frothing, minimize preheating in a circulation system.

Changing Materials

Changing the material types used in your equipment requires special attention to avoid equipment damage and downtime.

- When changing materials, flush the equipment multiple times to ensure it is thoroughly clean.
- Always clean the fluid inlet strainers after flushing.
- Check with your material manufacturer for chemical compatibility.
- When changing between epoxies and urethanes or polyureas, disassemble and clean all fluid components and change hoses. Epoxies often have amines on the B (hardener) side. Polyureas often have amines on the B (resin) side.

Proportioner Models

E-30i Series

Part	Available Auxiliary Current at 240 V, 60 Hz*★	Includes:		Voltage (phase)	Total System Load † (Watts)	Max Flow Rate lb/min (kg/min)	Approximate Output per Cycle (A+B) gal. (liter)	Maximum Fluid Working Pressure (MPa, bar)
		Booster Heat (4000 Watts)	Air Compressor (5000 Watts)					
259079	50 Amps			240 V (1)	7,700	30 (13.5)	0.0272 (0.1034)	2000 (13.8, 138)
259080	32 Amps	✓		240 V (1)	11,700	30 (13.5)	0.0272 (0.1034)	2000 (13.8, 138)
259089 ◆	30 Amps		✓	240 V (1)	7,700	30 (13.5)	0.0272 (0.1034)	2000 (13.8, 138)
259090 ◆	12 Amps	✓	✓	240 V (1)	16,700	30 (13.5)	0.0272 (0.1034)	2000 (13.8, 138)

E-XP2i Series

Part	Available Auxiliary Current at 240 V, 60 Hz*★	Includes:		Voltage (phase)	Total System Load † (Watts)	Max Flow Rate gpm (lpm)	Approximate Output per Cycle (A+B) gal. (liter)	Maximum Fluid Working Pressure (MPa, bar)
		Booster Heat (4000 Watts)	Air Compressor (5000 Watts)					
259081	32 Amps	✓		240 V (1)	11,700	2.0 (7.6)	0.0203 (0.0771)	3500 (24.1, 241)
259091 ◆	12 Amps	✓	✓	240 V (1)	16,700	2.0 (7.6)	0.0203 (0.0771)	3500 (24.1, 241)

† Total system watts used by system, based on maximum heated hose length of 310 ft (94.5 m) for each unit.

* Full load amps available for auxiliary equipment when all bare-system components are operating at maximum capabilities. Available auxiliary current is based on 310 ft (94.5 m) of heated hose. An additional 3.0 amps of auxiliary current is available for each 50 ft (15.2 m) section of heated hose that is not used.



★ Available auxiliary current will be less when the engine is de-rated for site altitude. Reduce the Available Auxiliary Current in the chart by 2.5 Amps per 1000 ft (300 m) elevation increments. If the available auxiliary current is less than zero, the system configuration may not support the full load at that altitude.

◆ Includes Complete Air Compressor Kit 24K335.

Refer to [Circuit Breaker Configuration Options, page 29](#).

See [Approvals, page 10](#).

Approvals

Model	Approvals:
259079	 <p>Intertek</p> <p>Conforms to ANSI/UL Std. 73 Certified to CAN/CSA Std. C22.2 No. 68</p>
259080	 <p>Intertek</p> <p>Conforms to ANSI/UL Std. 499 Certified to CAN/CSA Std. C22.2 No. 88</p>
259081	

Systems

Part	Maximum Fluid Working Pressure psi (MPa, bar)	Proportioner	Remote Display Module Kit	Heated Hose		Gun	
				50 ft (15 m)	10 ft (3 m)	Model	Part
AP9079	2000 (13.8, 138)	259079		24K240	246050	Fusion™ AP	246101
AP9080	2000 (13.8, 138)	259080		24K240	246050	Fusion™ AP	246101
AP9081	3500 (24.1, 241)	259081		24K241	246055	Fusion™ AP	246100
AP9179	2000 (13.8, 138)	259079	✓	24K394	246050	Fusion™ AP	246101
AP9180	2000 (13.8, 138)	259080	✓	24K394	246050	Fusion™ AP	246101
AP9181	3500 (24.1, 241)	259081	✓	24K395	246055	Fusion™ AP	246100
CS9079	2000 (13.8, 138)	259079		24K240	246050	Fusion™ CS	CS0101
CS9080	2000 (13.8, 138)	259080		24K240	246050	Fusion™ CS	CS0101
CS9081	3500 (24.1, 241)	259081		24K241	246055	Fusion™ CS	CS0000
CS9179	2000 (13.8, 138)	259079	✓	24K394	246050	Fusion™ CS	CS0101
CS9180	2000 (13.8, 138)	259080	✓	24K394	246050	Fusion™ CS	CS0101
CS9181	3500 (24.1, 241)	259081	✓	24K395	246055	Fusion™ CS	CS0000
P29079	2000 (13.8, 138)	259079		24K240	246050	Probler® P2	GCP2R1
P29080	2000 (13.8, 138)	259080		24K240	246050	Probler® P2	GCP2R1
P29081	3500 (24.1, 241)	259081		24K241	246055	Probler® P2	GCP2R0
P29179	2000 (13.8, 138)	259079	✓	24K394	246050	Probler® P2	GCP2R1
P29180	2000 (13.8, 138)	259080	✓	24K394	246050	Probler® P2	GCP2R1
P29181	3500 (24.1, 241)	259081	✓	24K395	246055	Probler® P2	GCP2R0

Systems with Air Compressor

Part	Maximum Fluid Working Pressure psi (MPa, bar)	Proportioner	Air Compressor	Remote Display Module Kit	Heated Hose		Gun	
					50 ft (15 m)	10 ft (3 m)	Model	Part
AP9089	2000 (13.8, 138)	259089	✓		24K240	246050	Fusion™ AP	246101
AP9090	2000 (13.8, 138)	259090	✓		24K240	246050	Fusion™ AP	246101
AP9091	3500 (24.1, 241)	259091	✓		24K241	246055	Fusion™ AP	246100
AP9189	2000 (13.8, 138)	259089	✓	✓	24K394	246050	Fusion™ AP	246101
AP9190	2000 (13.8, 138)	259090	✓	✓	24K394	246050	Fusion™ AP	246101
AP9191	3500 (24.1, 241)	259091	✓	✓	24K395	246055	Fusion™ AP	246100
CS9089	2000 (13.8, 138)	259089	✓		24K240	246050	Fusion™ CS	CS0101
CS9090	2000 (13.8, 138)	259090	✓		24K240	246050	Fusion™ CS	CS0101
CS9091	3500 (24.1, 241)	259091	✓		24K241	246055	Fusion™ CS	CS0000
CS9189	2000 (13.8, 138)	259089	✓	✓	24K394	246050	Fusion™ CS	CS0101
CS9190	2000 (13.8, 138)	259090	✓	✓	24K394	246050	Fusion™ CS	CS0101
CS9191	3500 (24.1, 241)	259091	✓	✓	24K395	246055	Fusion™ CS	CS0000
P29089	2000 (13.8, 138)	259089	✓		24K240	246050	Probler® P2	GCP2R1
P29090	2000 (13.8, 138)	259090	✓		24K240	246050	Probler® P2	GCP2R1
P29091	3500 (24.1, 241)	259091	✓		24K241	246055	Probler® P2	GCP2R0
P29189	2000 (13.8, 138)	259089	✓	✓	24K394	246050	Probler® P2	GCP2R1
P29190	2000 (13.8, 138)	259090	✓	✓	24K394	246050	Probler® P2	GCP2R1
P29191	3500 (24.1, 241)	259091	✓	✓	24K395	246055	Probler® P2	GCP2R0

Accessories

Kit Number	Description
24N449	50 ft (15 m) CAN cable (for remote display module)
24K207	Fluid Temperature Sensor (FTS) with RTD
24K338	Remote Display Module Kit
24K335	Complete Air Compressor Kit
125970	Air Compressor (without air supply tank)
24M490	Air Compressor (mounted 30 gallon tank)
24M125	Air Tank (12 gallons, 113.5 liters)
24M178	Air Dryer (desiccant)
24M258	Compressor Rack (frame only)
24K336	Hose Rack

Kit Number	Description
15V551	ADM Protective Covers (10 pack)
15M483	Remote Display Module Protective Covers (10 pack)
24K334	Feed Pump Shutdown Kit
24K333	Fuel Line and Cable Extension Kit
24K337	Light Tower Kit
24M174	Drum Level Sticks
24L911	Pallet Support Kit
121006	150 ft (45 m) cable (for remote display module)
24N365	RTD Test Cables (to aide resistance measurements)

Supplied Manuals

The following manuals are shipped with the Reactor. Refer to these manuals for detailed equipment information.

Manuals are also available at www.graco.com.

Manual	Description
3A1705	Reactor E-30i and E-XP2i, Operation
16K761	Reactor E-30i and E-XP2i, Startup Instructions
16K913	Reactor E-30i and E-XP2i, Shutdown Instructions
SEBU8311-02	Perkins® Engine, Repair-Parts <i>Access at www.perkins.com. Go to Service and Support/manuals. Select engine family and type code "GN".</i> <i>Contact Perkins for engine warranty and service.</i>
–	Mecc Alte Self-Regulating Alternator Series NPE, Repair-Parts <i>Access at www.meccalte.com. Select "meccalte" logo / Download / Instruction Manuals. Select NPE instruction manual on page 5. Go to Support and enter serial number for Parts List and Help Videos.</i> <i>Contact Mecc Alte for warranty and service.</i>
F3231, ver 16	Champion Air Compressor, Operation/Maintenance & Parts list. <i>For warranty and service call Gardner-Denver Customer Service (866) 276-3440 or Champion (815) 875-3321.</i>

Related Manuals

The following manuals are for accessories used with the Reactor.

Manuals are available at www.graco.com

Component manuals in English:

System Manuals	
3A1706	Reactor E-30i and E-XP2i, Repair-Parts
Displacement Pump Manual	
309577	Electric Reactor Displacement Pump, Repair-Parts
Feed System Manuals	
309572	Heated Hose, Instructions-Parts
309852	Circulation and Return Tube Kit, Instructions-Parts
309815	Feed Pump Kits, Instructions-Parts
309827	Feed Pump Air Supply Kit, Instructions-Parts
Spray Gun Manuals	
309550	Fusion™ AP Gun
312666	Fusion™ CS Gun
313213	Probler P2 Gun
Accessory Manuals	
3A1902	Compressor Rack, Instructions-Parts
3A1903	Hose Rack, Instructions-Parts
3A1904	Fuel Tank/Battery Move Kit, Instructions-Parts
3A1905	Feed Pump Shutdown Kit, Instructions-Parts
3A1906	Light Tower Kit, Instructions-Parts
3A1907	Remote Display Module, Instructions-Parts
3A2574	Pallet Support Kit, Instructions-Parts

Typical Installation, with circulation

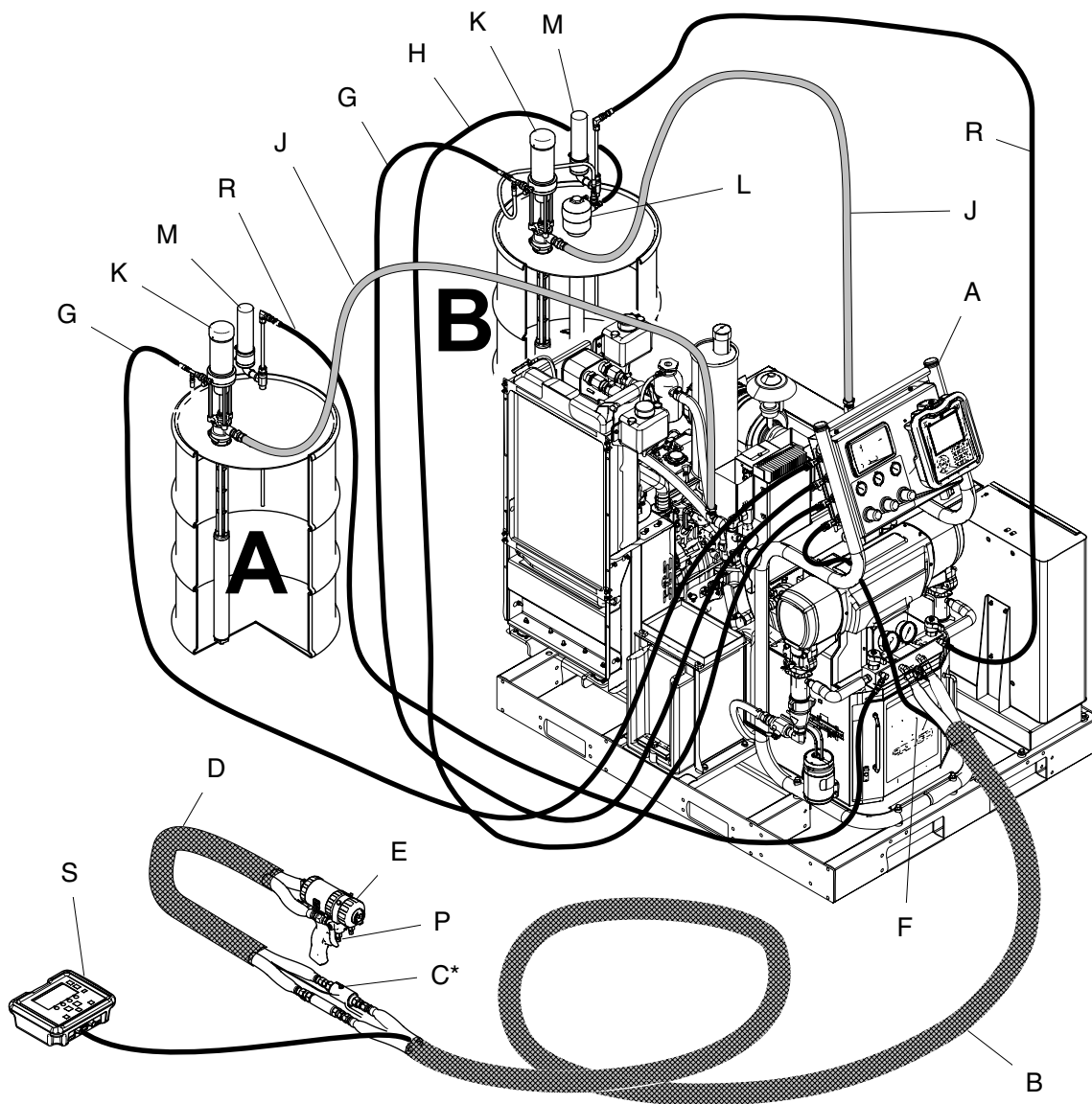

Figure 1

* Shown exposed for clarity. Wrap with tape during operation.

- | | | | |
|---|--------------------------------|---|----------------------------------|
| A | Reactor Proportioner | J | Fluid Supply Lines |
| B | Heated Hose | K | Feed Pumps |
| C | Fluid Temperature Sensor (FTS) | L | Agitator |
| D | Heated Whip Hose | M | Desiccant Dryer |
| E | Fusion Spray Gun | P | Gun Fluid Manifold (part of gun) |
| F | Gun Air Supply Hose | R | Recirculation Lines |
| G | Feed Pump Air Supply Lines | S | Remote Display Module (optional) |
| H | Agitator Air Supply Line | | |

Typical Installation, without circulation

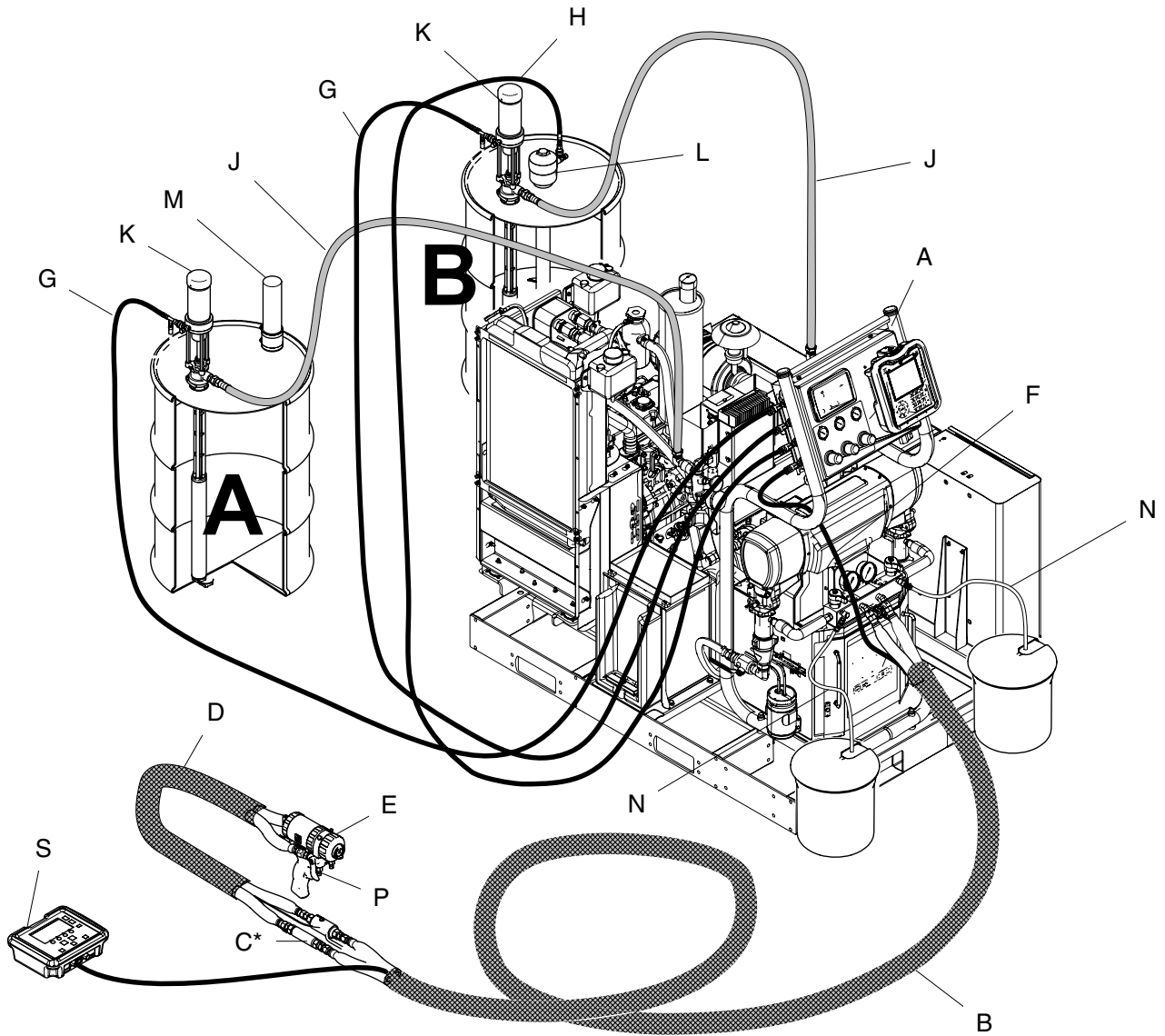
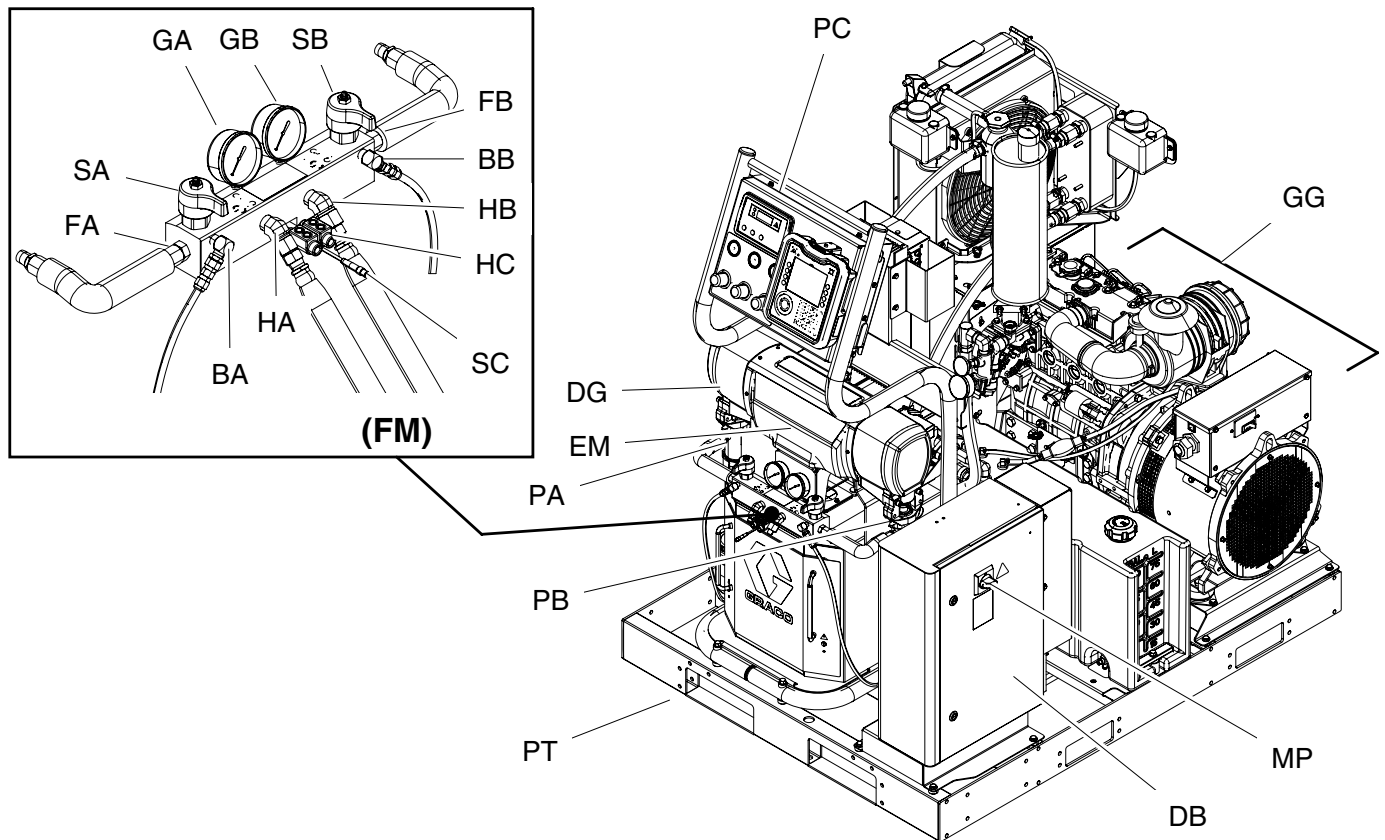

Figure 2

* Shown exposed for clarity. Wrap with tape during operation.

A	Reactor Proportioner	J	Fluid Supply Lines
B	Heated Hose	K	Feed Pumps
C	Fluid Temperature Sensor (FTS)	L	Agitator
D	Heated Whip Hose	M	Desiccant Dryer
E	Fusion Spray Gun	N	Bleed Lines
F	Gun Air Supply Hose	P	Gun Fluid Manifold (part of gun)
G	Feed Pump Air Supply Lines	S	Remote Display Module Kit (optional)
H	Agitator Air Supply Line		

Component Identification



Front View
Figure 3

- BA Component A Pressure Relief Outlet
- BB Component B Pressure Relief Outlet
- DG Drive Gear Housing
- DB Electrical Enclosure
- EM Electric Motor
- FA Component A Fluid Manifold Inlet
- FB Component B Fluid Manifold Inlet
- FM Reactor Fluid Manifold
- GA Component A Pressure Gauge
- GB Component B Pressure Gauge
- GG [Generator, page 17](#)
- HA Component A Hose Connection
- HB Component B Hose Connection

- HC Heated Hose Electrical Connectors
- MP Main Power Switch
- PA Component A Pump
- PB Component B Pump (behind Electrical Enclosure)
- PC [Proportioner Control Panel, page 18](#)
- PT Pallet
- SA Component A PRESSURE RELIEF/SPRAY Valve
- SB Component B PRESSURE RELIEF/SPRAY Valve
- SC Fluid Temperature Sensor (FTS) Cable
- TA Component A Pressure Transducer (behind gauge GA)
- TB Component B Pressure Transducer (behind gauge GB)

Component Identification

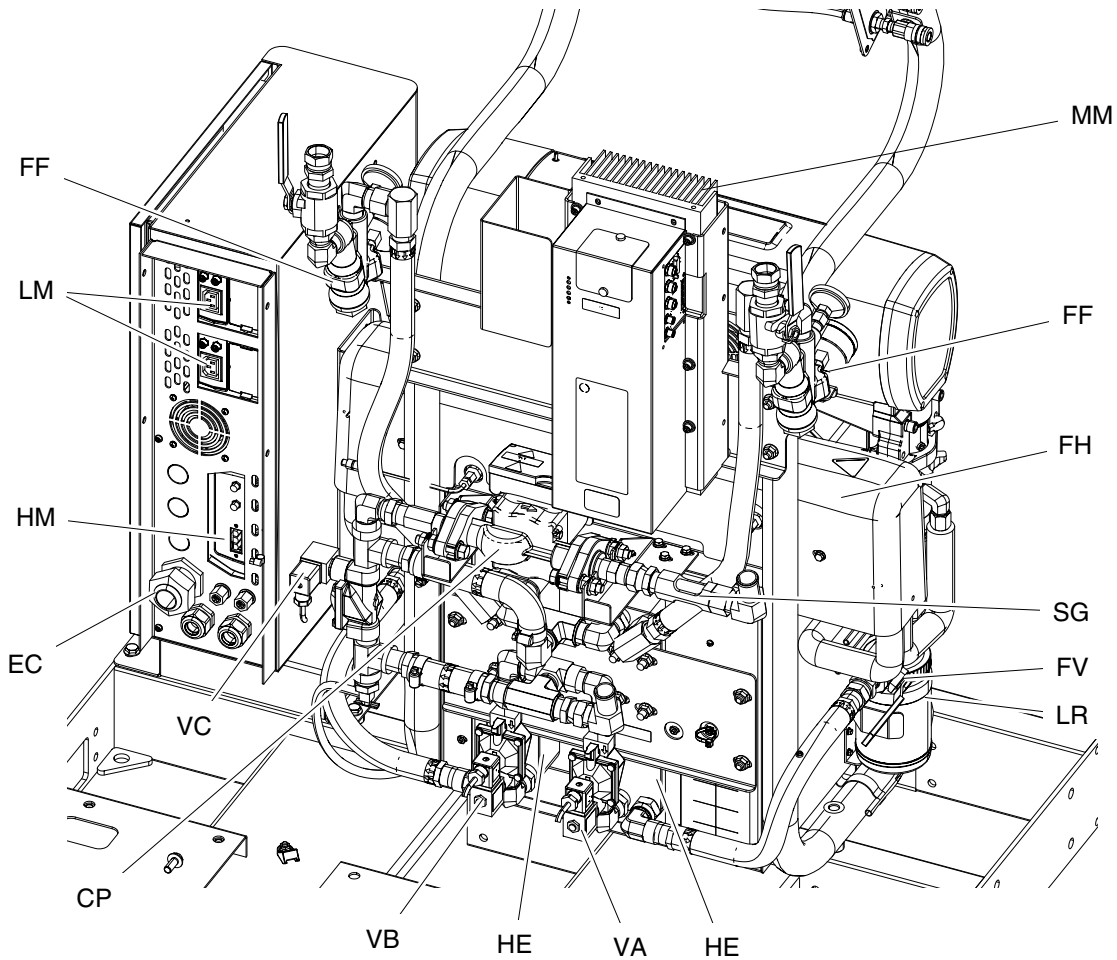

Back View
Figure 4

CP	Circulation Pump
EC	Electrical Cord Strain Relief
FF	Y-strainer (includes pressure gauge and temperature gauge)
FH	Booster Fluid Heater (not included with all models)
FV	Fluid Inlet Valve (A side shown)
HE	Heat Exchangers (heat exchanger coolant loop)
HM	High Power Temperature Control Module (HPTCM) Cable Connections, page 26

LM	Low Power Module (LPTCM) Cable Connections, page 26 (not included with all models)
LR	ISO Pump Lubricant Reservoir
MM	Motor Control Module (MCM), page 23
SG	Sight Glass
VA	Component A Control Valve
VB	Component B Control Valve
VC	Bypass Control Valve

Generator

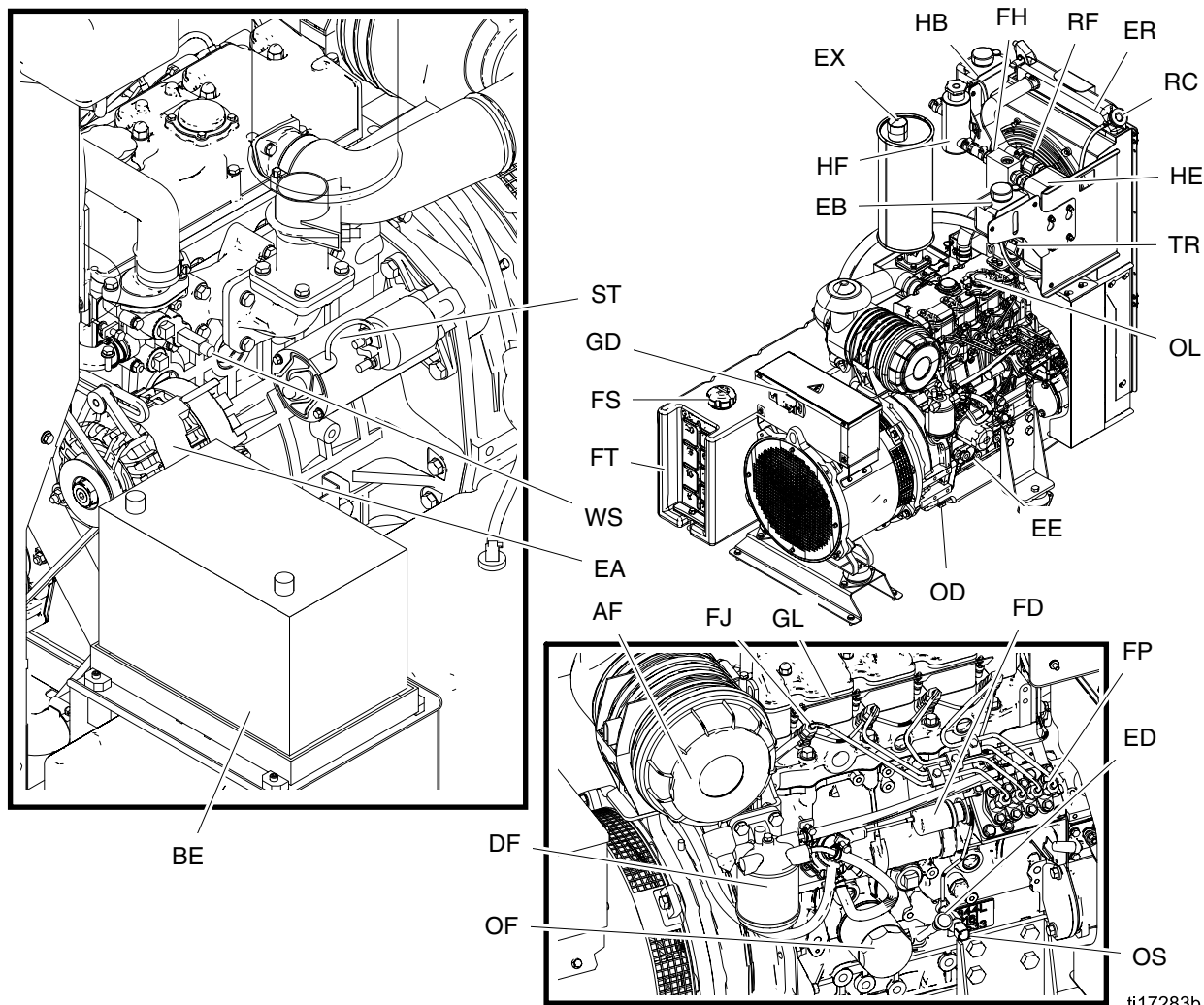

Figure 5

- AF Air Filter
- BE Battery (not supplied)
- DF Diesel Fuel Filter
- EA 12V Charge Alternator
- EB Engine Coolant Expansion Bottle
- EE Engine
- ED Engine Oil Dipstick
- ER Radiator
- EX Exhaust
- FD Fuel Shutoff Solenoid
- FH Filter Housing
- FJ Fuel Injector
- FP Fuel Pump
- FS Diesel Fuel Fill Cap

- FT Diesel Fuel Tank
- GD Generator Power Distribution Box
- GL Glow Plugs
- HB Heat Exchanger Coolant Expansion Bottle
- HE Heat Exchanger
- HF Heat Exchanger Coolant Fill Bottle
- OD Oil Drain
- OF Oil Filter
- OL Oil Fill
- OS Oil Pressure Switch
- RC Engine Coolant Radiator Cap
- RF Radiator Fan
- ST Starter
- TR Coolant Temperature Sensor
- WS Over-Temperature Switch

Proportioner Control Panel

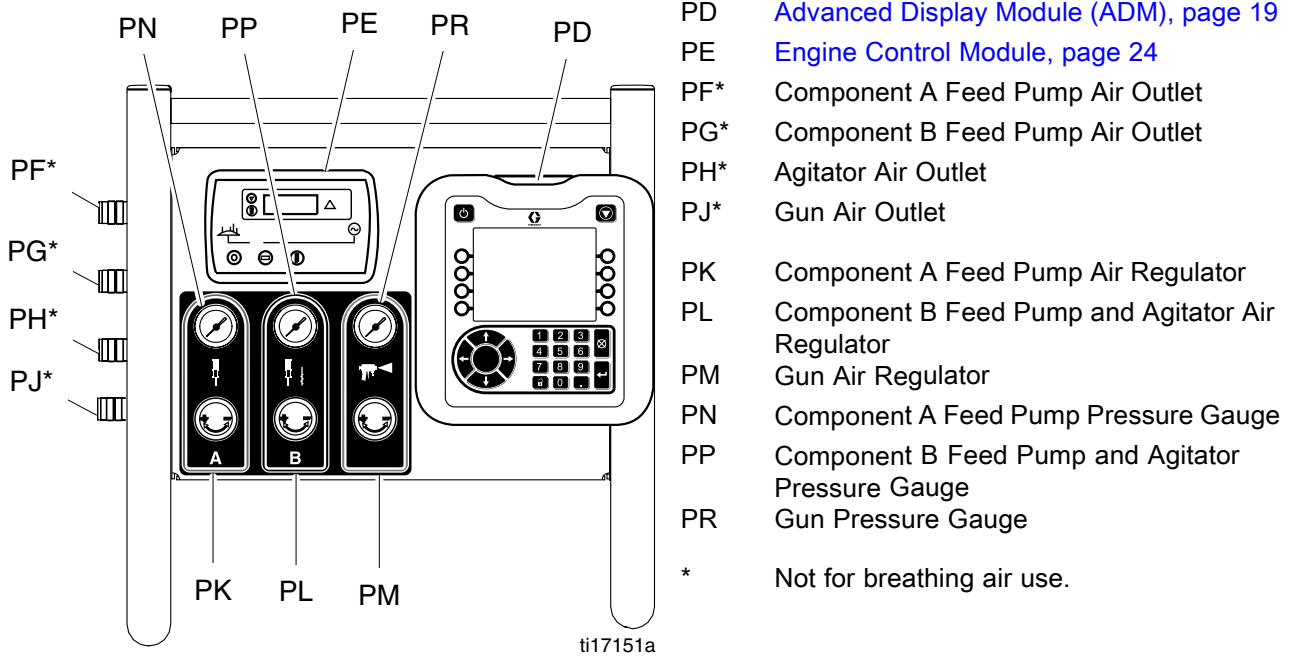

Figure 6

Air Compressor

Select models are supplied with an air compressor. To order as an accessory, see [Accessories, page 11](#).

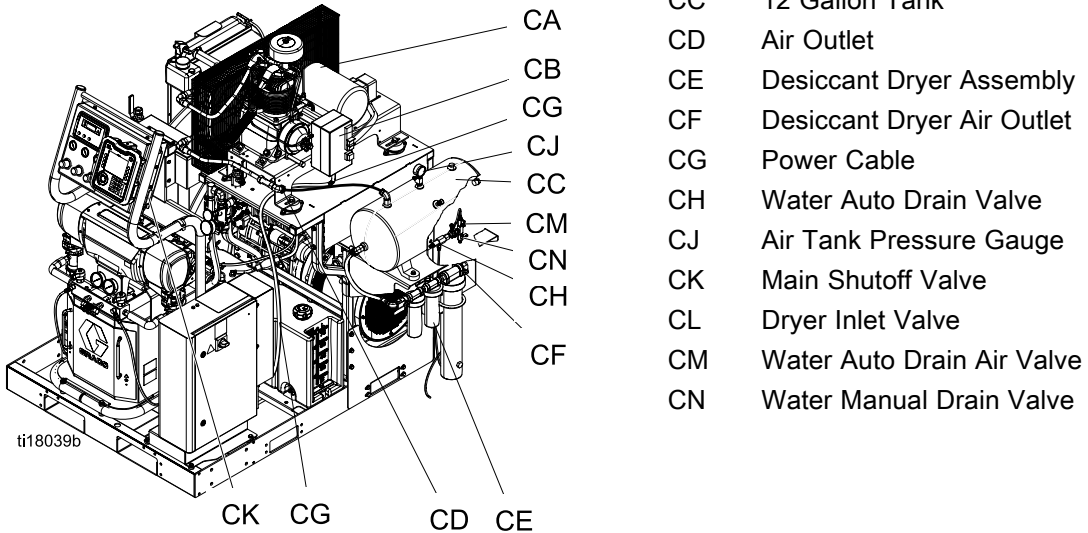
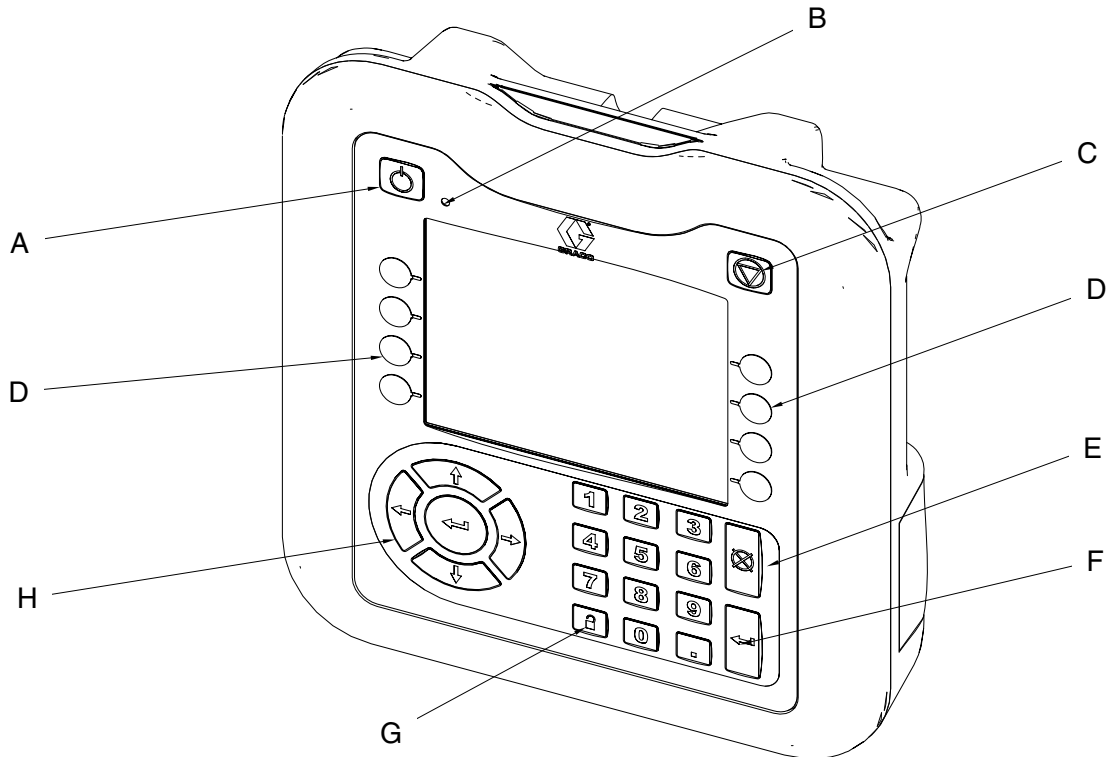

Figure 7

Advanced Display Module (ADM)

NOTICE

To prevent damage to the softkey buttons, do not press buttons with sharp objects such as pens, plastic cards, or fingernails.



Component Identification — Front
Figure 8

Call out	Button	Function
A	Power On/Off	Powers system on and off.
B	System Status Indicator Light	Displays system status.
C	Stop	Stops all system processes. Is not a safety or emergency stop.
D	Soft Keys	Selects the specific screen or operation shown on the display directly next to each key.

Call out	Button	Function
E	Cancel	Cancels a selection or number entry in progress.
F	Enter	Acknowledges a value change or makes a selection.
G	Lock/Setup	Toggles between run and setup screens. If setup screens are password protected, button toggles between run and password entry screens.
H	Navigation	Navigates within a screen or to a new screen.

Component Identification

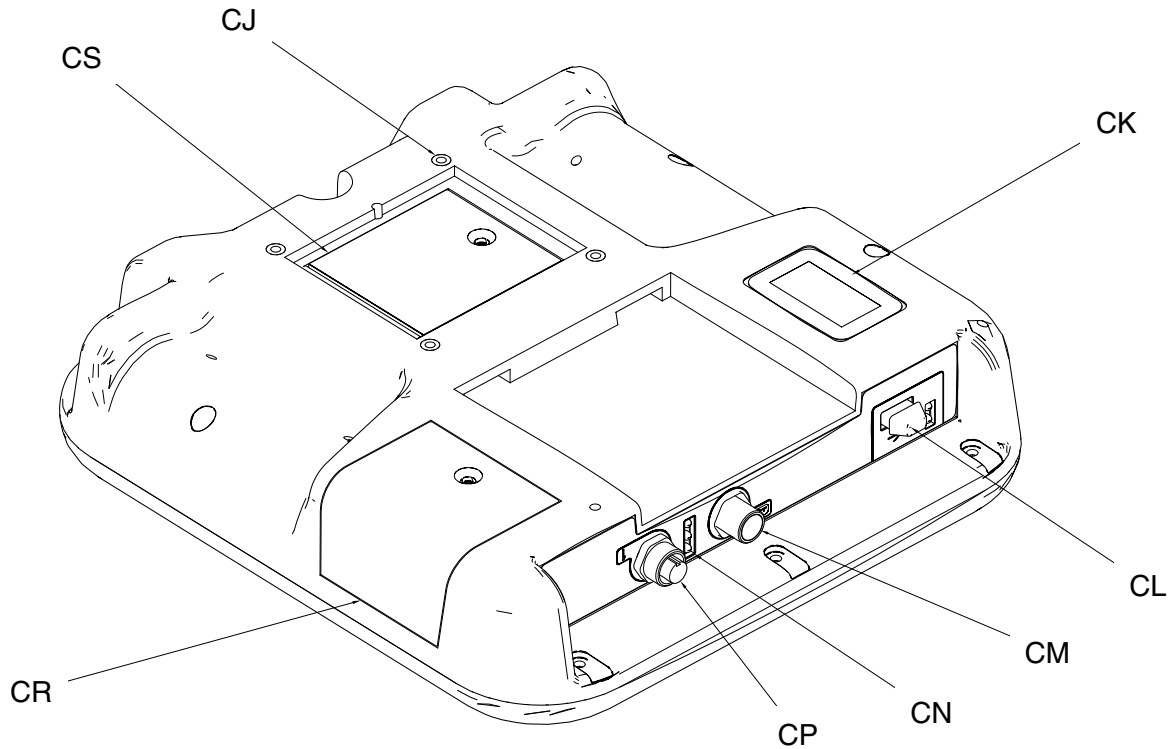

Component Identification — Back
Figure 9

CJ	Flat Panel Mount (VESA 100)
CK	Model and Serial Number
CL	USB Port and Status LEDs
CM	CAN Cable Connection
CN	Module Status LEDs
CP	Accessory Cable Connection
CR	Token Access Cover
CS	Battery Access Cover

System Status Indicator (B) Conditions

Green Solid — Run Mode, System On

Green Flashing - Setup Mode, System On

Yellow Solid - Run Mode, System Off

Yellow Flashing - Setup Mode, System Off

USB Module Status LEDs (CL) Conditions

Green Flashing - Data recording in progress

Yellow Solid - Downloading information to USB

Green and Yellow Flashing - ADM is busy, USB cannot transfer information when in this mode

Module Status LEDs (CN) Conditions

Green Solid - Power applied to module

Yellow Solid - Active Communication

Red Steady Flashing - Software upload from token in progress

Red Random Flashing or Solid - Module error exists

ADM Display Details

Power Up Screen

The following screen appears when the ADM is powered up. It remains on while the ADM runs through initialization and establishes communication with other modules in the system.



Menu Bar

The menu bar appears at the top of each screen. (The following image is only an example.)



Date and Time

The date and time are always displayed in one of the following formats. The time is always displayed as a 24-hour clock.

- DD/MM/YY HH:MM
- YY/MM/DD HH:MM
- MM/DD/YY HH:MM

Arrows

The left and right arrows indicate screen navigation.

Screen Menu

The screen menu indicates the currently active screen, which is highlighted. It also indicates the associated screens that are available by scrolling left and right.

System Mode

The current system mode is displayed at the lower left of the menu bar.

Alarm/Deviation

The current system error is displayed in the middle of the menu bar. There are four possibilities:

Icon	Function
No Icon	No information or no error has occurred
	Advisory
	Deviation
	Alarm

Status

The current system status is displayed at the lower right of the menu bar.

Soft Keys

Icons next to the soft keys indicate which mode or action is associated with each soft key. Soft keys that do not have an icon next to them are not active in the current screen.

NOTICE

To prevent damage to the soft key buttons, do not press buttons with sharp objects such as pens, plastic cards, or fingernails.

Jump In/Jump Out

In screens that have editable fields, press to access the fields and make changes. When changes are complete press again to exit edit mode.

Navigation within Screens

Press to open drop-down menus on Setup screens.











Press to enter changes or make a selection.

Press to navigate to new screens and to navigate left and right within a screen. Press to select digits to change within a field.

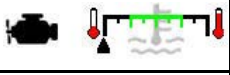



















Press to navigate to new screens and to navigate up and down within a screen. Also press to move between fields within a drop-down menu, and to increment or decrement numbers within a field.

Icons

Icons

Icon	Function
	Component A
	Component B
	Estimated Supply Material
	Hose Temperature
	Jog Mode Speed
	Engine Coolant Temperature
	Pressure
	Cycle Counter (press and hold)
	Advisory. See Errors, page 51 for more information.
	Deviation. See Errors, page 51 for more information
	Alarm. See Errors, page 51 for more information

Softkeys

Icon	Function
	Start Proportioner
	Start and Stop Proportioner in Jog Mode
	Stop Proportioner
	Turn on specified heat zone.
	Park component A pump
	Enter Jog Mode. See Jog Mode, page 60
	Reset Cycle Counter (press and hold)
	Select Recipe
	Search
	Move Cursor Left One Character
	Move Cursor Right One Character
	Toggle between upper-case, lower-case, and numbers and special characters.
	Backspace
	Cancel
	Clear
	Troubleshoot Selected Error
	Increase value
	Decrease value
	Next screen
	Previous screen
	Return to first screen

Motor Control Module (MCM)

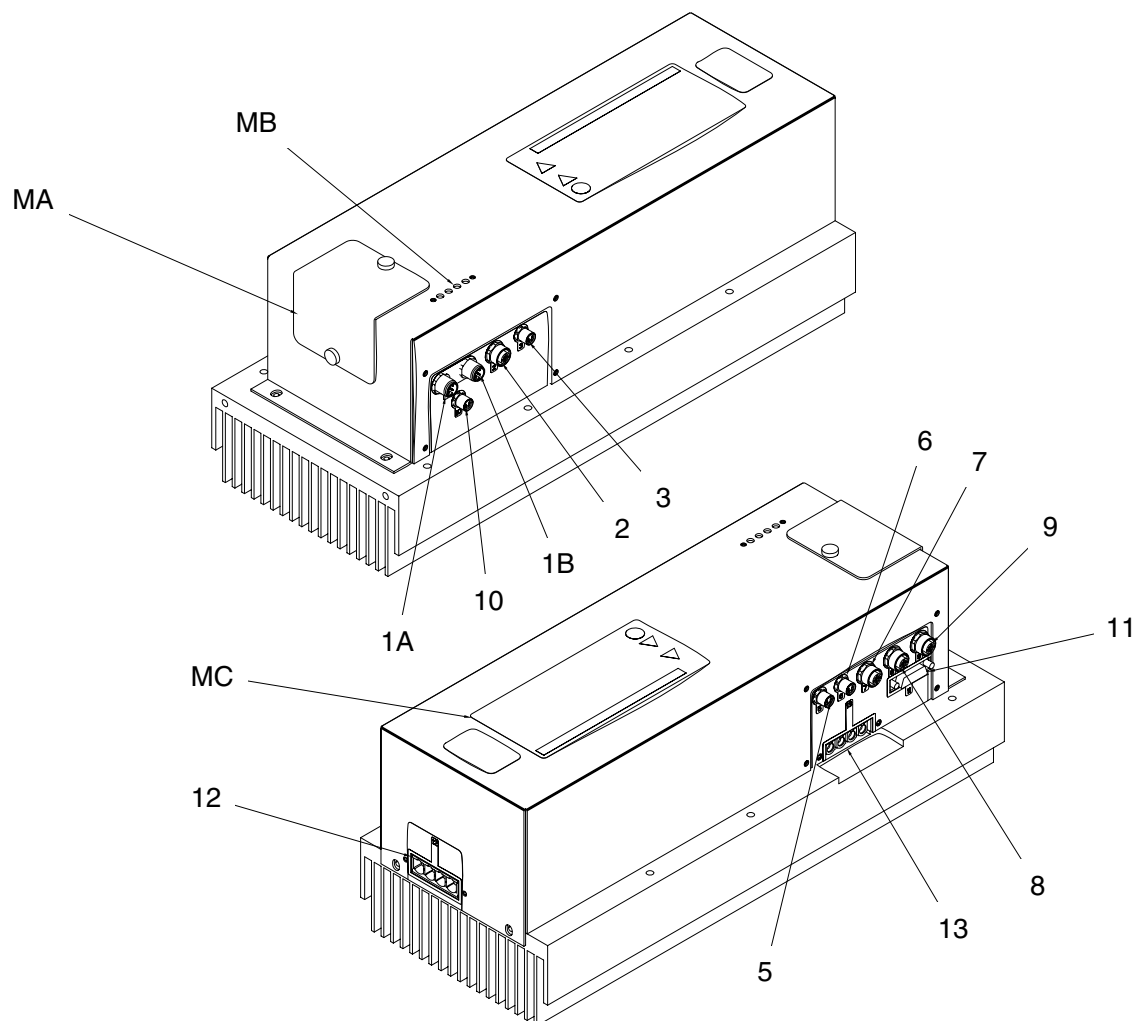

Motor Control Module

Figure 10

MA	Token and Rotary Switch Access Cover	7	Optional Accessory Connection: Feed Pump Shut Down Kit
MB	Module Status LEDs see Module Status LEDs (CN) Conditions, page 20	8	Pressure Transducer B (Blue) side
MC	Warning Label	9	Pressure Transducer A (Red) side
1A,	CAN Communication Connections	10	Motor Brush Wear and Over-Temperature Sensor Connection
1B		11	Not used
2	Heat Exchanger Control Valve Output (to load center)	12	MCM Power Input Connection
3	Two-way Splitter to A and B Heat Exchanger Temperature Sensors	13	Motor Power Connection
5	Engine Coolant Temperature Sensor		
6	Pump Cycle Switch		

MCM Rotary Switch Positions

- 0=E-30i
- 1=E-XP2i

Engine Control Module

NOTICE

To prevent damage to the softkey buttons, do not press buttons with sharp objects such as pens, plastic cards, or fingernails.

For more information about the engine control module, see [Appendix A: Engine Control Module, page 93](#).

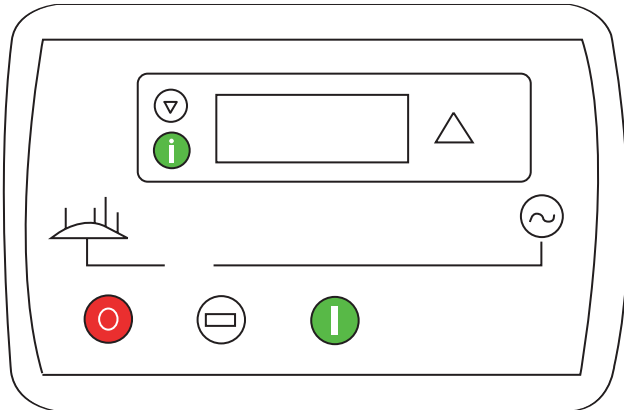
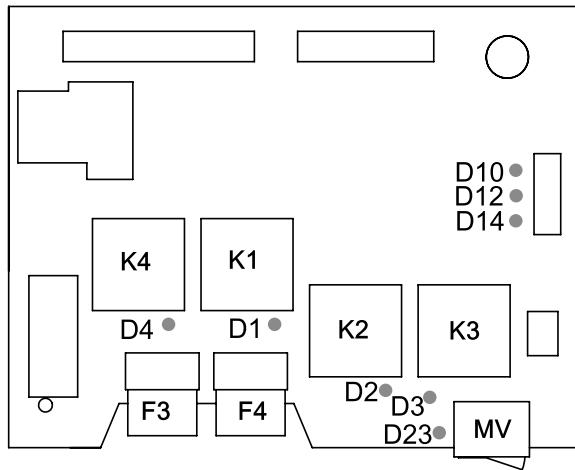

Figure 11

Engine Control Module

Icon	Description	Function
	On	Start Engine
	Auto	Auto mode (not used)
	Off	Stop all system processes. Is not a safety or emergency stop.
	Scroll	Scroll through the instruments or recorded events on the currently displayed page
	Page Select	Toggle between the information page and the error log page
	Error Lamp	Indicates error is present on generator

Load Center



- F3 Radiator Fan Fuse
- F4 Load Center Power Fuse
- K1 Fuel Relay
- K2 Starter Relay
- K3 Glow Plug Relay
- K4 Radiator Fan Relay
- MV Manual Valve Switch

LED	Related Component	Color	ON-State Description
D1	Fuel Shutoff Solenoid (FS)	Green	Fuel shutoff solenoid on the engine is open.
D2	Starter (ST)	Red	Starter is cranking.
D3	Glow Plugs (GL)	Green	Glow plugs are heating.
D4	Radiator Fan (RF)	Green	Radiator fan is on.
D10	A Coolant Valve	Red	A-side (red) coolant valve is open.
D12	B Coolant Valve	Blue	B-side (blue) coolant valve is open.
D14	Bypass Coolant Valve	Green	Bypass coolant valve is open.
D23	Manual Valve Switch (MV)	Red	Manual valve switch is in the ON position.

Temperature Control Modules

Located inside the Electrical Enclosure (DB).

High Power Temperature Control Module (HPTCM) Cable Connections

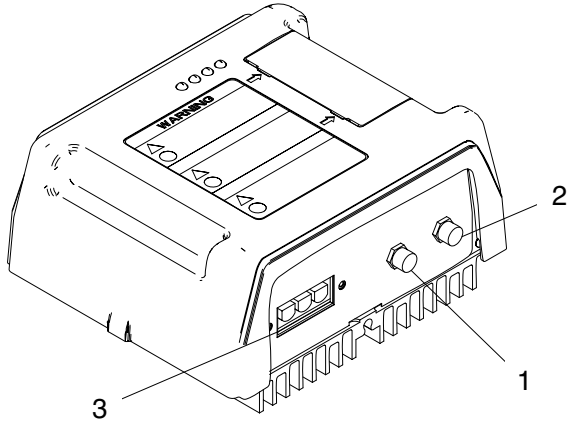

Figure 12

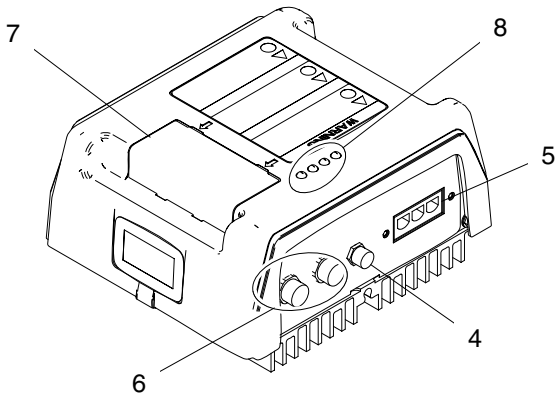

Figure 13

- 1 Not used
- 2 Fluid Temperature Sensor (FTS) Connection
- 3 Output Power Connection
- 4 Contactor Control Connection
- 5 Input Power Connection
- 6 CAN Communications Connections
- 7 Rotary Switch, Token Access
- 8 Module Status LEDs (see [Advanced Display Module \(ADM\), page 19, \(CN\)](#) for conditions)

Low Power Module (LPTCM) Cable Connections

Only used with E-XP2i and E-30i models with booster heat.

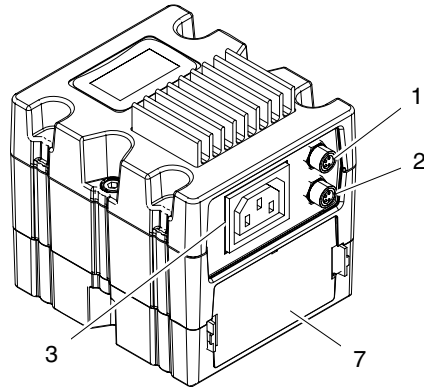

Figure 14

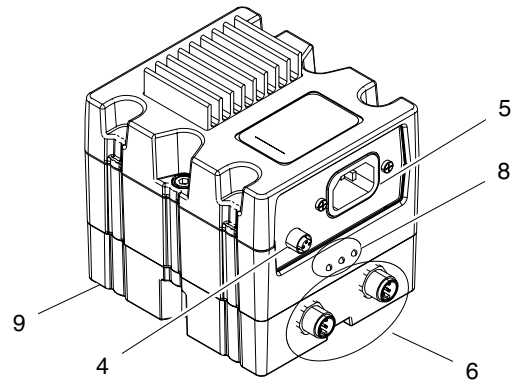

Figure 15

- 1 Over-Temperature Switch Connection
- 2 Booster Heat Temperature Sensor Connection
- 3 Output Power Connection
- 4 Not used
- 5 Input Power Connection
- 6 CAN Communications Connections
- 7 Rotary Switch, Token Access
- 8 Module Status LEDs (see [Advanced Display Module \(ADM\), page 19, \(CN\)](#) for conditions)
- 9 Base

Adjust Rotary Switch

The rotary switch setting indicates which zone the temperature control module will control in the system. The HPTCM uses an 8-position rotary switch. The LPTCM uses a 16-position rotary switch.

Set the rotary switch (S) to the specific selection according to the settings listed in the following tables.

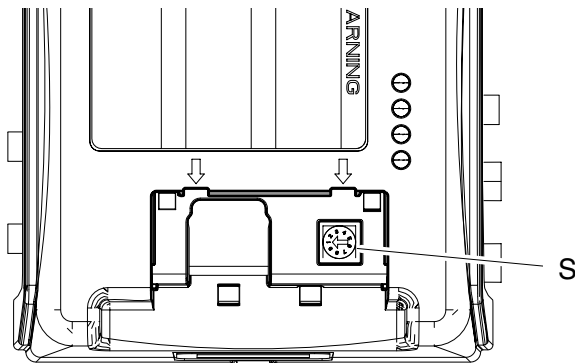

HPTCM Rotary Switch Location
Figure 16

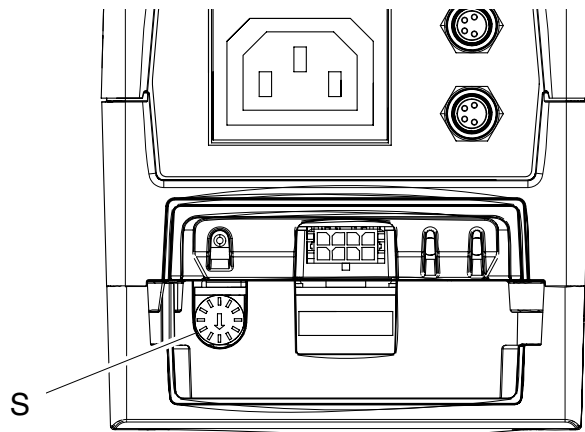

LPTCM Rotary Switch Location
Figure 17

HPTCM A and B Rotary Switch Settings

Setting	Zone
0	Heated Hose
1	Not Used
2	Not Used
3	Not Used
4	Not Used
5	Not Used
6	Not Used
7	Not Used

LPTCM A and B Rotary Switch Settings

Setting	Zone
0	Not Used
1	Not Used
2	Not Used
3	Not Used
4	Not Used
5	Not Used
6	Not Used
7	Not Used
8	Not Used
9	Not Used
A	Booster Heat A
B	Booster Heat B
C	Not Used
D	Not Used
E	Not Used
F	Not Used

Circuit Breakers

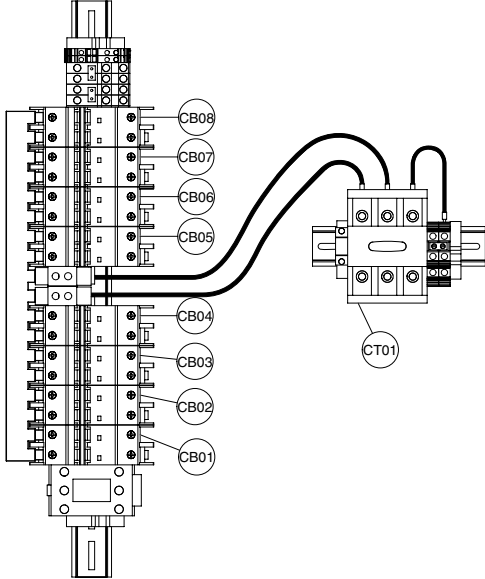
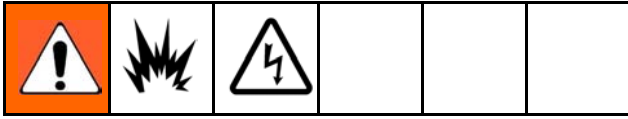

Circuit Breakers Inside Electrical Enclosure (DB)
Figure 18

Note

Not all wires are shown.

Ref.	Size	Component
CB01	30 A	High Power Temperature Control Module (HPTCM)
CB02	20 A	Motor Control Module (MCM)
CB03	5 A	Two Motor Fans, Cabinet Fan, Power Supply, and Coolant Circulation Pump
CB04*	30 A	Auxiliary Power (Air Compressor)
CB05*	10 A	Auxiliary Power
CB06*	20 A	Auxiliary Power
CB07	15 A	E-XP2i and E-30i With Heat: Low Power Temperature Control Module (LPTCM) A
		E-30i: Auxiliary
CB08	15 A	E-XP2i and E-30i With Heat: Low Power Temperature Control Module (LPTCM) B
		E-30i: Auxiliary

* See [Circuit Breaker Configuration Options](#), page 29.

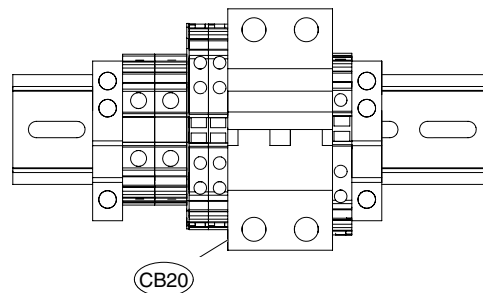

Circuit Breakers Inside Proportioner Cabinet
Figure 19

Ref.	Size	Component
CB20	50 A	Heated Hose

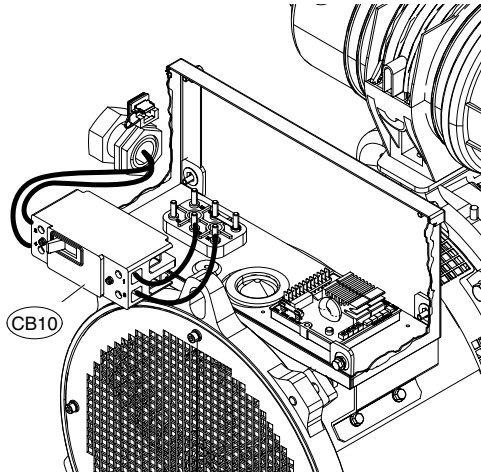

Circuit Breakers Inside Alternator Assembly
Figure 20

Ref.	Size	Component
CB10	90 A	120/240V Alternator

Circuit Breaker Configuration Options

<p>Improper configuration can result in electric shock. All changes from the recommended circuit breaker configuration must meet all National, State, and Local safety and electrical codes. Consult a qualified electrician before attempting any changes. See page 27 and 28 for correct circuit breaker configuration.</p>					

The Electrical Enclosure (DB) circuit breaker configuration described in the tables on the previous page is the recommended configuration.

Sub-Panel Options

Some customer changes are acceptable to accommodate larger loads from auxiliary equipment or a sub-panel. It is suggested that circuit breakers

CB04 be substituted to accommodate larger loads or a sub-panel. The total auxiliary equipment loads added to the configuration must be limited to the system's available auxiliary current. See [Proportioner Models, page 9](#), for available auxiliary current at 240V, 60Hz.

See the Reactor repair manual for optional circuit breakers and their current ratings. Circuit breakers used must meet UL489 specifications.

Auxiliary Wiring Diagram Options.

The generator supplies power in a 3-wire, single-phase, mid-point neutral wiring configuration. For 240 VAC loads, wire the load across the output terminals of the circuit breaker. For 120 VAC loads, wire the load between the neutral terminal blocks next to the three pole main power switch (CT01) to one pole of the circuit breaker. See electrical diagrams in Reactor repair manual.

Disable LPTCMs For Booster Heat

Both LPTCMs for booster heat must be disabled to allow use of power for additional auxiliary power.

1. Follow Shutdown instructions. See [Shutdown, page 63](#).
2. Refer to Disable Optional Booster Heater Wiring Diagram in the Reactor repair manual.

To replace or repair a circuit breaker, use the following steps:

1. Follow Shutdown instructions. See [Shutdown, page 63](#).
2. Refer to circuit breaker identification table and electrical diagrams in Reactor repair manual.
3. Loosen four screws connecting wires and bus bar to circuit breaker that will be replaced. Disconnect wires.
4. Pull locking tab out 1/4 in. (6mm) and pull circuit breaker away from the din rail. Install new circuit breaker. Insert wires and tighten down all screws.

Overview

The system uses two coolant loops to use heat released from the engine to heat the A and B component material to the target temperatures defined on the ADM (PD).

The engine coolant loop (gray) circulates heated coolant from the engine (EE), through the heat

exchanger (HE), radiator (ER), and back to the engine. Coolant in the proportioner coolant loop (black) captures heat from the engine coolant loop inside the heat exchanger (HE) near the radiator.

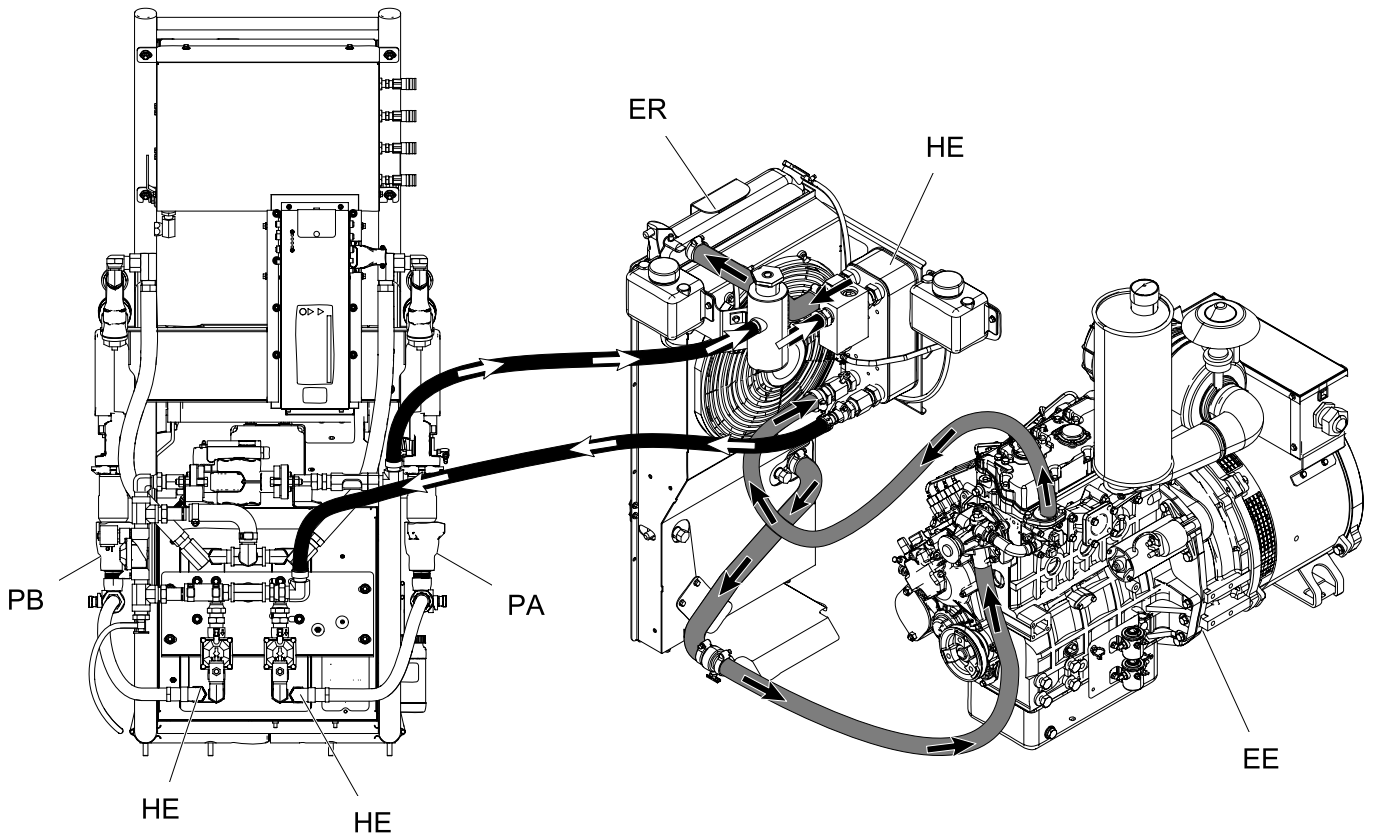

Engine Coolant Loop and Proportioner Coolant Loop
Figure 21

The proportioner coolant loop circulates coolant through secondary heat exchangers (HE) located on the back of the proportioner to heat the A and B component material before the material is pressurized in the proportioner pumps (PA, PB). After the A and B material has been heated in the heat exchangers, the material enters the fluid manifold (FM) and heated hose.

For models with a booster heater, the A and B material enters the booster heater after the material is pressurized in the proportioning pumps to heat the material higher than 140°F (60°C).

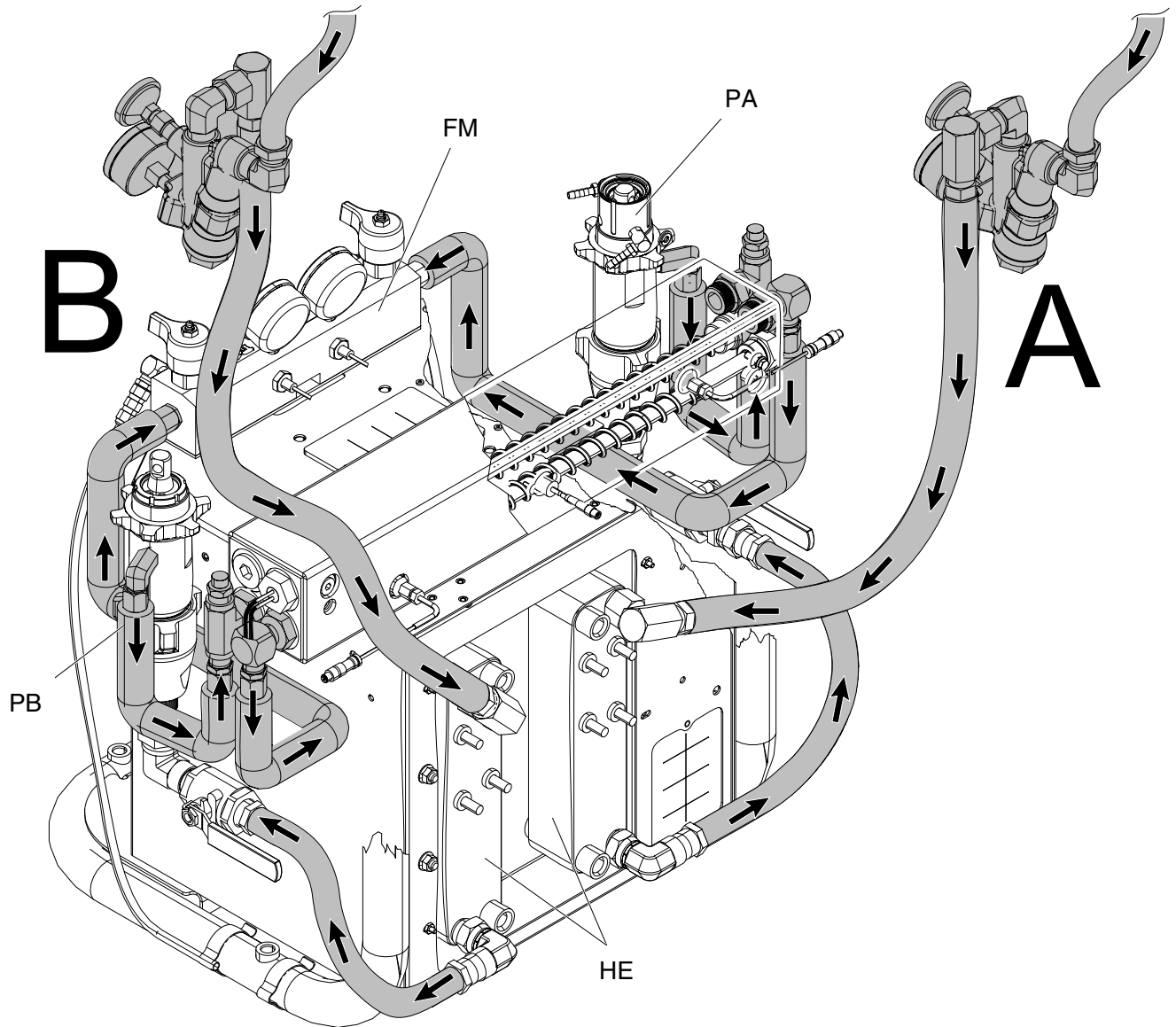

A and B Component Material Flow
Figure 22

Overview

Coolant only flows through the secondary heat exchangers when the heat exchanger control valves (VA, VB) are open and the A and B component temperatures are below the target temperatures set on the ADM. See Fig. 24.

When the control valves (VA, VB) close, the A and B material has reached target temperature. Coolant flows through the bypass control valve (VC), circulation pump (CP), sight glass (SG), proportioner coolant fill bottle (HF), and back to the heat exchanger in the engine coolant loop. See Fig. 23

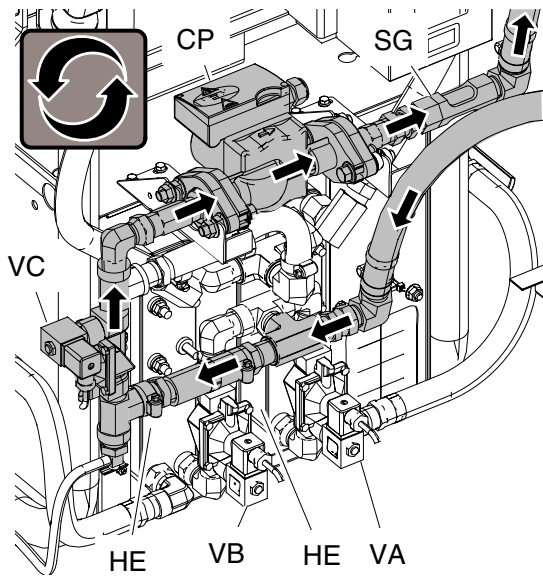

Proportioner Coolant Loop — A and B Valves Closed (not heating material)
Figure 23

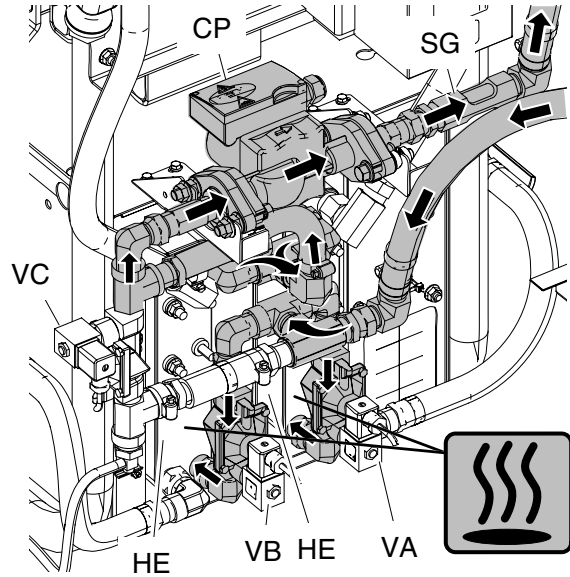

Proportioner Coolant Loop — A and B Valves Open (heating material)
Figure 24

Setup

NOTICE

Proper system setup, startup, and shutdown procedures are critical to electrical equipment reliability. The following procedures ensure steady voltage. Failure to follow these procedures will cause voltage fluctuations that can damage electrical equipment and void the warranty.

NOTICE

Do not remove or separate the proportioner, engine assembly, or power distribution box from the pallet. Failure to leave the component mounting intact will cause heating efficiency degradation, and potential unsafe wiring and grounding.

Locate Reactor

If system was not ordered with the air compressor, go to step 2.

1. For systems with an air compressor, install the air tank bracket assembly and connect air lines. For systems without an air compressor, order air compressor kit 24K335. See manual 3A1902 for complete installation instructions.

NOTICE

Only use air compressors with a continuous run head unloader. Repeated compressor motor startups will cause errors and shutdown the system. See [Technical Specifications, page 102](#) for recommended air compressors and requirements. Other models may be used, but motor must not stop and start during operation.

- a. Use at least two people to install the air tank assembly (AT). Secure to frame with supplied screws (AS) and nuts (AN). See illustration on next page.
- b. Remove u-bolt holding desiccant container and add all desiccant pellets (shipped separately). Replace u-bolt securely. See manual 309921.
- c. Connect air line (A1) between compressor and air tank inlet.

- d. Connect air line (A2) between proportioner air inlet to air dryer outlet.
 - e. Connect pilot air lines (A3 and A4) between the air compressor and air tank.
 - f. Secure water drain lines (A5 and A6) to the frame and drain outlets.
2. Install hose rack, if ordered. See manual 3A1903 for detailed instructions.
 3. Locate Reactor on a level surface that is nonporous and diesel resistant, such as diamond plate. See [Dimensions, page 96](#), for clearance and mounting hole dimensions.

Note

Leave at least 1 ft. (0.3m) distance from the engine side of the pallet to any wall for engine maintenance access. See [Fig. 27, page 37](#).
 4. Do not expose Reactor to rain or below 20°F (-7°C).

NOTICE

To ensure the heat exchanger control valves open and close properly, do not store Reactor below 20°F (-7°C).

5. If a wall will be installed between the proportioner and generator, remove the fuel tank and battery bracket. See [Trailer Setup Guidelines, page 35](#) for instructions.
6. To mount in a trailer, use forklift to move Reactor by inserting the forks through the Reactor pallet frame. It is recommended to lift from the engine side. Bolt pallet directly to trailer frame.

Note

Use Pallet Support Kit 24L911 (rollers not included) to relocate pallet to mounting location when forks are unavailable. See kit manual for instructions.

NOTICE

Keep the vent holes in the bottom of the proportioner cabinet open. Make sure there is unobstructed incoming air for the cooling fan at the top of the proportioner cabinet that blows air up into the electric motor. Failure to provide unobstructed incoming air can cause the motor to overheat.

Setup

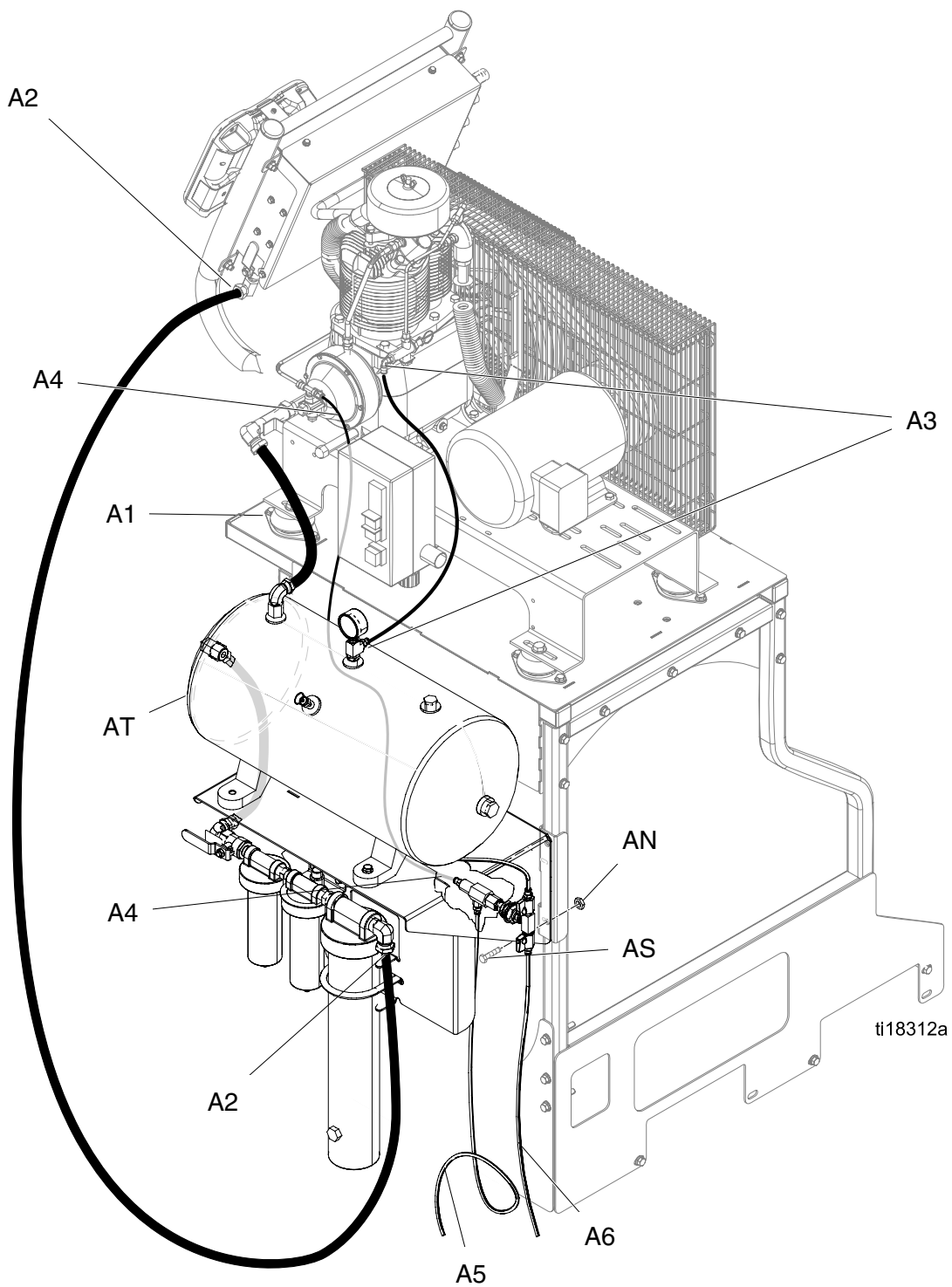

Trailer Setup Guidelines

					
Route exhaust system away from combustible materials to prevent materials from igniting or gas recirculation into a wall, ceiling, or a concealed space. Provide exhaust system guards to prevent burns.					

NOTICE

Provide recommended size louvers. Failure to do so can damage the engine and void the engine warranty.

Exhaust pipes that pass through flammable ceilings must be guarded by vented metal thimbles that extend at least 9 in. (228.6 mm) below and above the roof and are at least 6 in. (152.4 mm) in diameter larger than the exhaust pipe.

Exhaust pipes that pass through flammable walls must be guarded by either:

- Metal ventilated thimble at least 12 in. (305 mm) larger than the diameter of the exhaust pipe.
- Metal or other approved fireproofing materials that provides at least 8 in. (203 mm) of insulation between the exhaust pipe and flammable material.

Exhaust pipes not covered above must have at least 9 in. (228.6 mm) of clearance from the outside of the exhaust pipe to adjacent flammable materials.

1. Provide sufficient lighting to safely operate and maintain system equipment.

2. Provide radiator exhaust for Reactor. Use a 400 in.² (258,064 mm²) minimum louver.
3. Provide air duct to connect radiator exhaust to louver.
4. Provide a 400 in.² (258,064 mm²) minimum fresh air intake louver near the generator.
5. Remove red exhaust cap.
6. Provide a minimum 2 in. (50.8 mm) diameter engine exhaust outlet with flexible pipe element. Provide rain cap, or equivalent routing, to prevent moisture from entering the metal exhaust pipe.

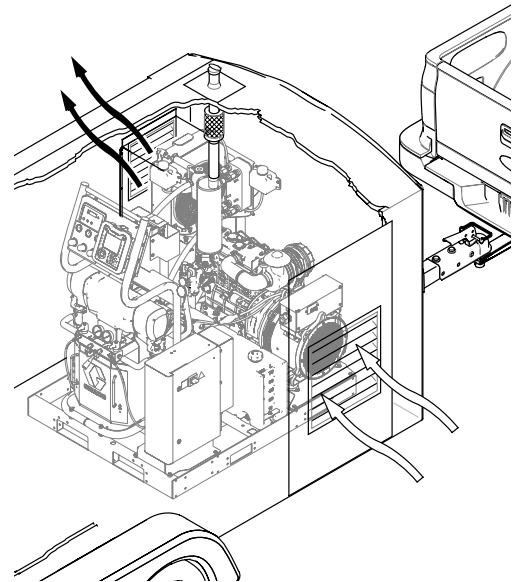

Radiator Exhaust and Air Intake Louvers
Figure 25

Install Wall (optional)

Install a wall between the proportioner and generator to:

- Temperature condition the trailer space where chemical is stored. Check with chemical manufacturer for chemical storage temperatures.
- Reduce noise for the operator while the Reactor is running.

The supplied fuel lines and battery cable may need to be replaced if a wall is installed between the proportioner and generator. Purchase the Fuel Line and Battery Cable Extension Kit 24K333.

1. If necessary drain coolant from system. See [Drain Coolant, page 69](#). Coolant lines do not need to be disconnected to install a wall.

Note

Battery must be connected to starter to drain coolant from system.

2. Remove screws and battery bracket from the pallet.

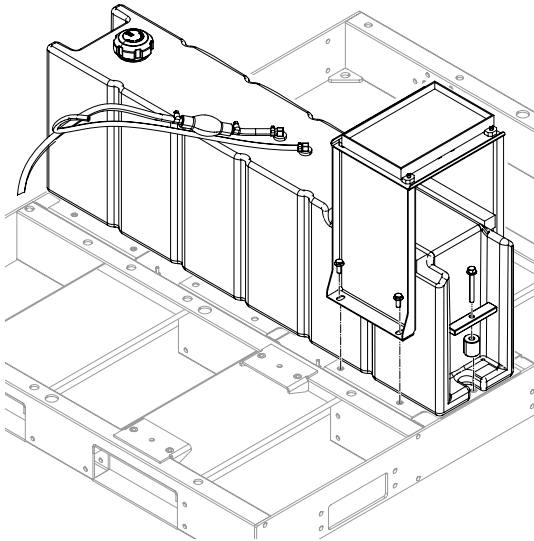

Remove Battery Bracket and Fuel Tank
Figure 26

3. Remove fuel tank from the pallet.
 - a. Remove the mounting screws, supports, and spacers.
 - b. Disconnect inlet and outlet fuel lines from the fuel tank.
 - c. Use two people to lift fuel tank off of the pallet and place where the fuel fill spout is easily accessible.

Note

Do not mount fuel tank in front of the generator air intake or where it will limit opening and access to the electrical enclosure (DB).

4. Install wall (IW) where the fuel tank was located. Ensure there is at least 1.25 in. (31.75 mm) between the wall, exhaust muffler, and MCM. See [Fig. 27, page 37](#).

Note

To prevent an air pocket from forming inside the coolant lines between the proportioner and generator, ensure there is a constant rise in elevation if the coolant lines are adjusted. Failure to have a constant rise in elevation will reduce heating efficiency. See [Fig. 28, page 37](#).

5. Reconnect inlet and outlet fuel lines.
6. Install spacers, supports, and screws through the fuel tank and tighten to the floor. Torque to 40 ft-lbs (54 N•m).
7. Place battery bracket over fuel tank or near the Reactor. Remove existing battery cables from engine and replace with the cables provided from the fuel line and battery cable extension kit.
8. Install mounting bolts through battery bracket and tighten to the floor. Torque to 40 ft-lbs (54 N•m).

Note

Pads under the battery bracket help stabilize the fuel tank during operation.

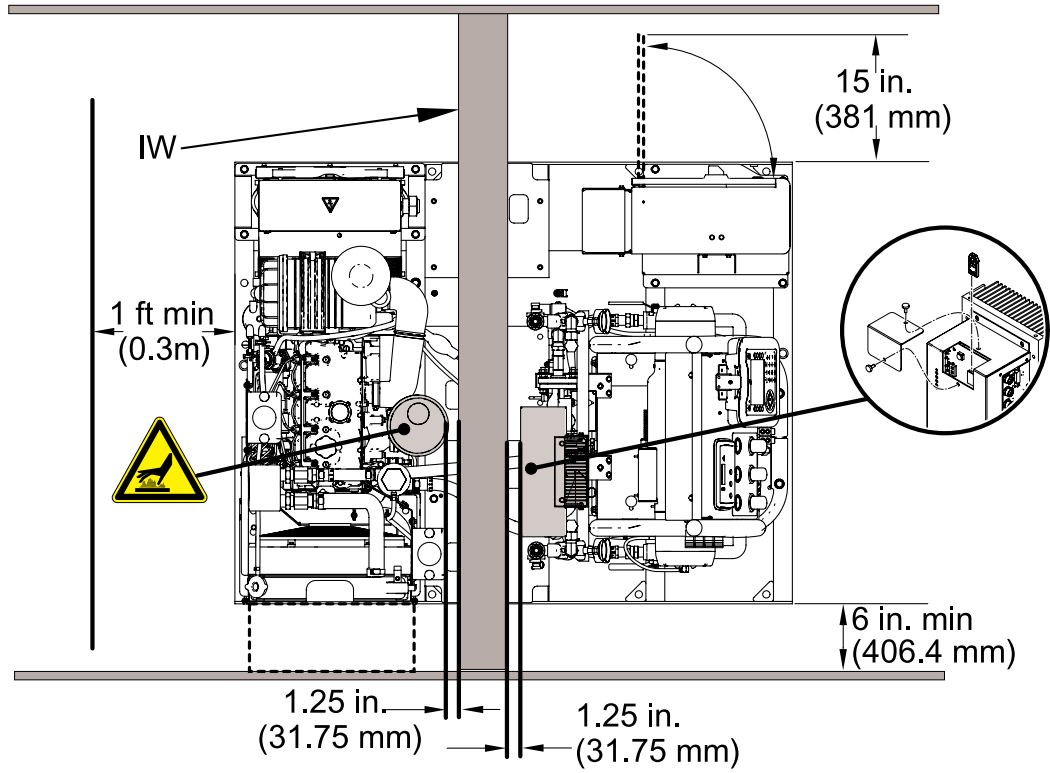



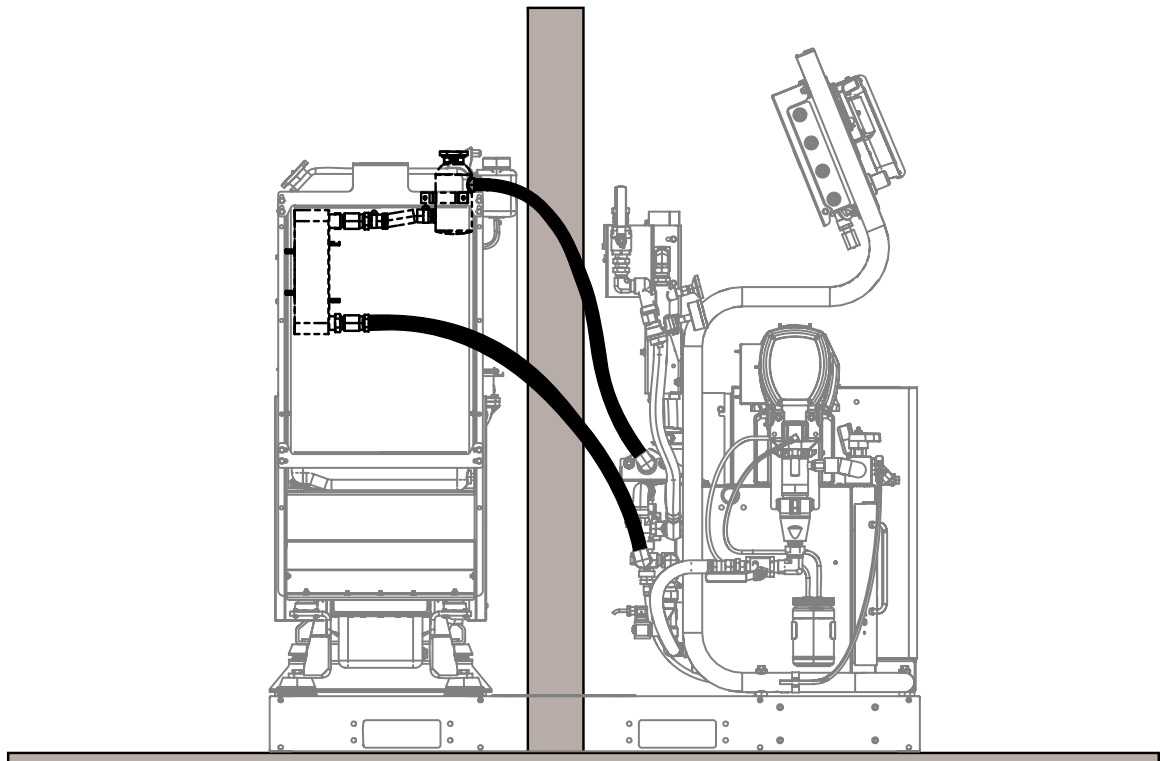

Top View With Wall
Figure 27



Side View With Wall
Figure 28

Connect Battery

					
<p>Improper battery installation or maintenance may result in electric shock, chemical burns, or explosion. Battery maintenance must only be performed or supervised by personnel knowledgeable of batteries and the required precautions. Keep unauthorized personnel away from batteries.</p>					

See [Technical Specifications, page 102](#) for battery requirements and recommended battery size.

1. Secure battery (not supplied) to bracket with strap.

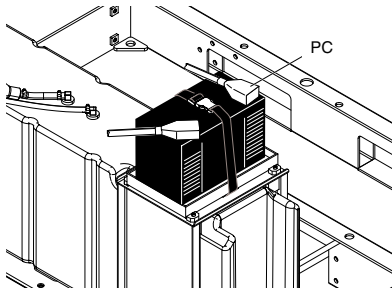

Figure 29

2. Connect battery cable from the engine starter (ST) and chassis to the battery. Connect the black cable to battery negative (-) and the red cable to battery positive (+).

NOTICE
<p>Always connect the red battery cable to battery positive (+) and the black battery cable to the battery negative (-). Failure to properly connect the battery cable to the battery will damage the fusible link when the engine control module is turned ON. Do not bypass the fusible link when damaged. The fusible link prevents damage to other system components. See the system repair manual for repair instructions.</p>

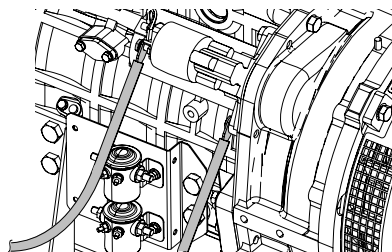



Figure 30

3. Cover battery terminals with plastic caps (PC) attached to supplied battery cables.
4. Verify battery was connected properly by pressing OFF  on the engine control module (PE) to “wake up” the controller screen. Do not attempt to start the engine until all Setup steps are complete. See Repair manual if engine control module doesn’t light up.

Add Fuel

1. Remove fuel cap (FS) and fill fuel tank with no more than 20 gallons (75 liters) of diesel fuel. Replace cap. See Perkins engine manual for approved diesel fuels.
2. Squeeze prime bulb (P) to prime engine. Press the prime bulb repeatedly until fuel begins to return to the fuel tank.

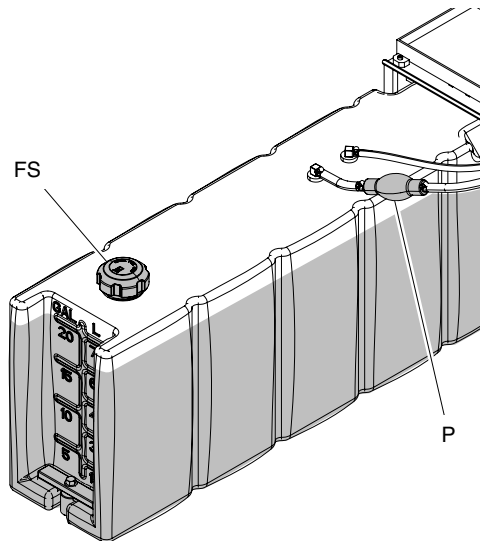

Figure 31

General Equipment Guidelines

Maintain and inspect the generator, air compressor, and other equipment per the manufacturer recommendations to avoid an unexpected shutdown. Unexpected equipment shutdown will cause voltage fluctuations that can damage electrical equipment.

Electrical Connections

Connect air compressor, breathing air, and auxiliary power electrical connections to the specified circuit breakers. See [Circuit Breakers, page 28](#).

1. Remove one or more knock-outs on side of electrical enclosure, as required, and route wires through for air compressor, breathing air, and auxiliary equipment. See [Circuit Breaker Configuration Options, page 29](#), for more information.

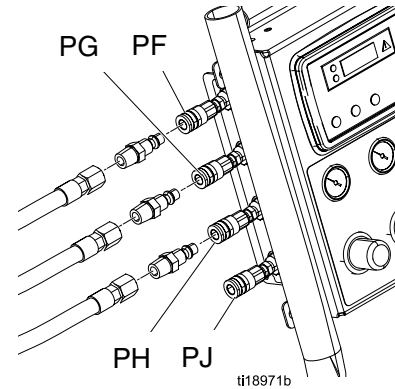

Connect Feed Pumps

1. Install feed pumps (K) in component A and B supply drums. See [Typical Installation, with circulation, page 13](#) and [Typical Installation, without circulation, page 14](#).
2. Seal component A drum and use desiccant dryer (M) in vent.
3. Install agitator (L) in component B drum, if necessary.
4. Connect supply hoses from feed pumps to the component A and component B material inlets on the system. Ensure A and B inlet valves are closed.

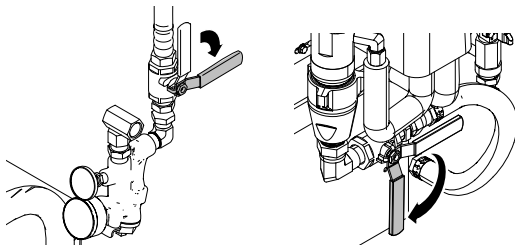

Note

Supply hoses from feed pumps should be 3/4 in. (199 mm) ID.

5. Connect air lines to proportioner. Ensure components are properly connected to correct location.

Ref	Air Outlet
PF	A Pump
PG	B Pump
PH	Agitator
PJ	Gun

Note

Agitator air supply (PH) includes a small internal restriction orifice to limit the air flow to minimize air compressor load. Maximum supplied air flow is 2.0 scfm (0.1 m³/min) at 100 psi (0.7 MPa, 7 bar). Designed for use with Twistork agitator 224854. Do not use the agitator air outlet (PH) for any other component.

Breathing Air

<p>Breathing the air from the compressed air supply can cause serious injury if inhaled.</p> <ul style="list-style-type: none"> • Only use an independent and approved breathing air system with adequate air flow to provide clean breathable air. 					

Connect Pressure Relief Lines

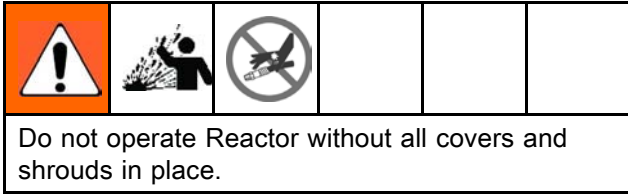

1. **Recommended:** Connect high pressure hose (R) to relief fittings (BA, BB) of both PRESSURE RELIEF/SPRAY valves. Route hose back to component A and B drums. See [Typical Installation, with circulation, page 13](#).
2. **Alternately:** Secure supplied bleed tubes (N) in grounded, sealed waste containers (H). See [Typical Installation, without circulation, page 14](#).

Install Fluid Temperature Sensor

The Fluid Temperature Sensor (FTS) is supplied. Install FTS between main hose and whip hose. See Heated Hose manual for instructions.

Connect Heated Hose

See Heated Hose manual for detailed instructions on connecting heated hoses.

Note

The FTS (C) and whip hose (D) must be used with heated hose. Hose length, including whip hose, must be 60 ft (18.3 m) minimum.

NOTICE

Apply grease on all system and hose fluid fittings. This lubricates the threads and prevents material from hardening on the threads.



1. Turn main power switch OFF
2. Assemble heated hose sections, FTS, and whip hose.
3. Connect A and B hoses to A and B outlets on Reactor fluid manifold (FM). Hoses are color

coded: red for component A (ISO), blue for component B (RES). Fittings are sized to prevent connection errors.

Note

Manifold hose adapters (HA, HB) allow use of 1/4 in. and 3/8 in. ID fluid hoses. To use 1/2 in. (13 mm) ID fluid hoses, remove adapters from fluid manifold and install as needed to connect whip hose.

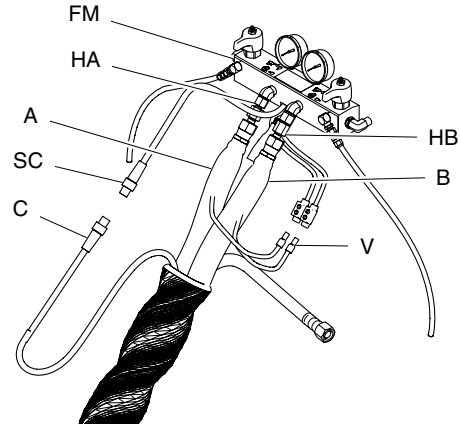

Figure 32

4. Connect cables (C). Connect electrical connectors (V). Be sure cables have slack when hose bends. Wrap cable and electrical connections with electrical tape.
5. Connect quick-disconnect pin fitting to 4 ft air hose, shipped loose. Connect other hose end to the gun air hose in the heated hose bundle. Push pin fitting into the lowest air panel outlet (PJ).

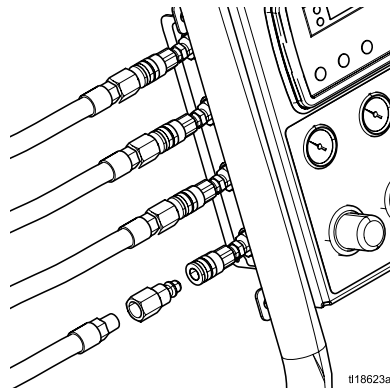
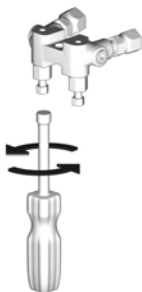

Figure 33

Close gun fluid manifold valves A and B



Connect Whip Hose to Gun Or Gun Fluid Manifold

See hose manual for proper connections.

Pressure Check Hose

See hose manual. Pressure check for leaks. If no leaks, wrap hose and electrical connections to protect from damage.

Connect Remote Display Module

See Remote Display Module kit manual for installation instructions.

Grounding

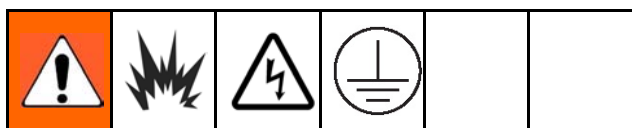

The equipment must be grounded to reduce the risk of static sparking and electric shock. Electric or static sparking can cause fumes to ignite or explode. Improper grounding can cause electric shock. Grounding provides an escape wire for the electric current.

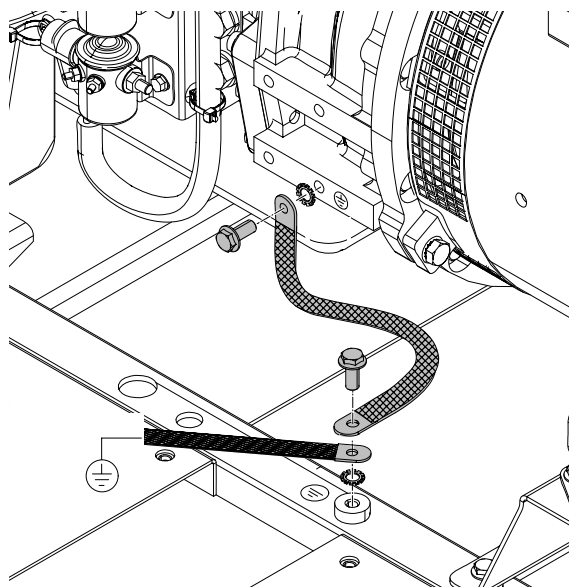

- *Reactor System:* System must be grounded with an appropriately sized conductor to the trailer

or vehicle chassis or, if stationary, to true earth ground. Remove bolt and braided cable from pallet. Install grounding cable terminated with a ring terminal (cable and terminal not supplied) under braided cable. Reinstall bolt and torque to minimum 25 ft-lbs (34 N·m). An alternate grounding location is to the ground bar (CB02) in the electrical enclosure. Follow all National, State, and Local safety and fire codes.



- *Spray gun:* connect whip hose ground wire to FTS. See [Install Fluid Temperature Sensor, page 40](#). Do not disconnect ground wire or spray without whip hose.
- *Fluid supply containers:* follow your local code.
- *Object being sprayed:* follow your local code.
- *Solvent pails used when flushing:* follow your local code. Use only metal pails, which are conductive, placed on a grounded surface. Do not place pail on a nonconductive surface, such as paper or cardboard, which interrupts grounding continuity.
- *To maintain grounding continuity when flushing or relieving pressure,* hold a metal part of spray gun firmly to the side of a grounded *metal* pail, then trigger gun.

Supply Wet Cups With Throat Seal Liquid (TSL)

					
<p>Pump rod and connecting rod move during operation. Moving parts can cause serious injury such as pinching or amputation. Keep hands and fingers away from wet-cup during operation.</p>					

To prevent the pump from moving, turn the main power switch OFF.



- **Component A (ISO) Pump:** Keep reservoir (R) filled with Graco Throat Seal Liquid (TSL), Part 206995. Wet-cup piston circulates TSL through wet-cup, to carry away isocyanate film on displacement rod.

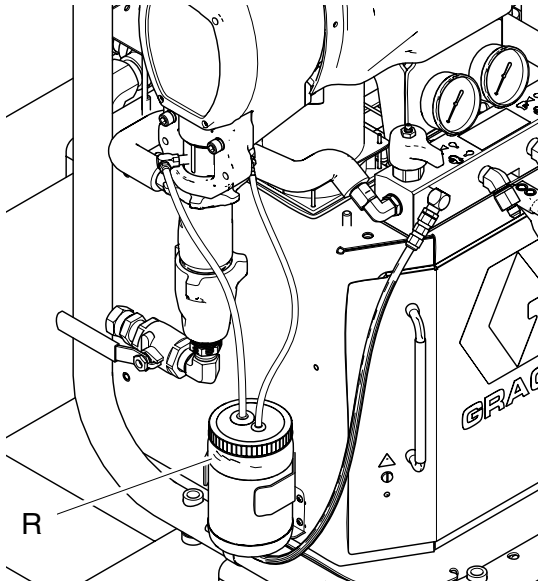

Component A Pump
Figure 34

- **Component B (Resin) Pump:** Check felt washers in packing nut/wet-cup (S) daily. Keep saturated with Graco Throat Seal Liquid (TSL), Part No. 206995, to prevent material from hardening on displacement rod. Replace felt washers when worn or contaminated with hardened material.

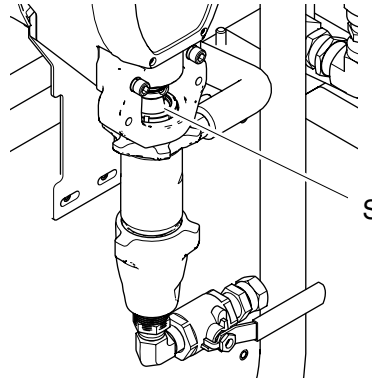



Component B Pump
Figure 35

Advanced Display Module (ADM) Operation

When main power is turned on by turning the main power switch (MP) to the ON position, the splash screen will be displayed until communication and initialization is complete.



Then the power key icon screen will display until the ADM power on/off button (A)  is pressed for the first time after system power-up.



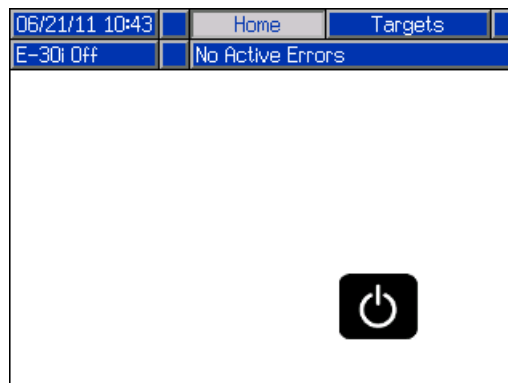

To begin using the ADM, the machine must be active. To verify the machine is active, verify that the System Status Indicator Light (B) is illuminated green, see [Advanced Display Module \(ADM\), page 19](#). If the System Status Indicator Light is not green, press the ADM Power On/Off (A) button . The System Status Indicator Light will illuminate yellow if the machine is disabled.



Perform the following tasks to fully setup your system.

1. Select pressure for the Pressure Imbalance Alarm to activate. See [System Screen , page 47](#).
2. Enter, enable, or disable recipes. See [Recipes Screen, page 47](#).
3. Set general system settings. See [Advanced Screen 1 — General, page 46](#).
4. Set units of measure. See [Advanced Screen 2 — Units, page 46](#).
5. Set USB settings. See [Advanced Screen 3— USB, page 46](#).
6. Set target temperatures and pressure. See [Targets, page 50](#).
7. Set component A and component B supply levels. See [Maintenance, page 51](#).
8. Ensure engine is at operating temperature on the home screen.

Setup Mode

The ADM will start in the Run screens at the Home screen. From the Run screens, press  to access the Setup screens. The system defaults with no password, entered as 0000. Enter the current password then press . Press   to navigate through the Setup Mode screens. See [Setup Screens Navigation Diagram, page 45](#).

Set Password

Set a password to allow Setup screen access, see [Advanced Screen 1 – General, page 46](#). Enter any number from 0001 to 9999. To remove the password, enter the current password in the Advanced Screen – General screen and change the password to 0000.

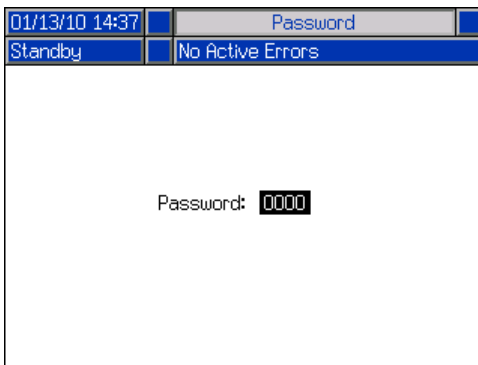



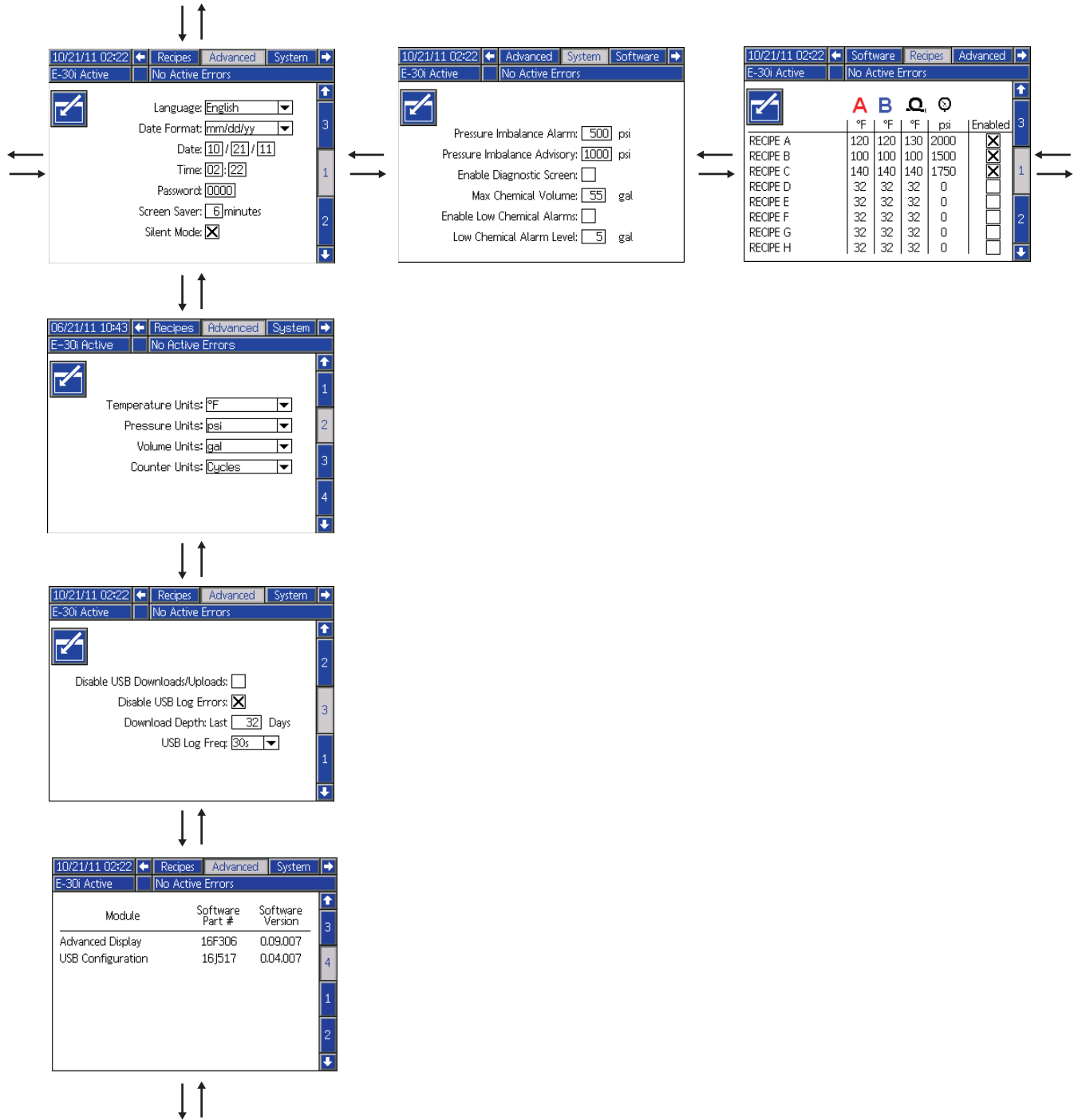

From the Setup screens, press  to return to the Run screens.



Setup Screens Navigation Diagram
 Figure 36

Advanced Setup Screens

Advanced setup screens enable users to set units, adjust values, set formats, and view software information for each component. Press   to scroll through the Advanced setup screens, Once in the desired Advanced setup screen, press  to access the fields and make changes. When changes are complete press  to exit edit mode.

Note

Users must be out of edit mode to scroll through the Advanced setup screens.

Advanced Screen 1 — General

Use this screen to set the language, date format, current date, time, setup screens password (0000 – for none) or (0001 to 9999), screen saver delay, and enable or disable silent mode.

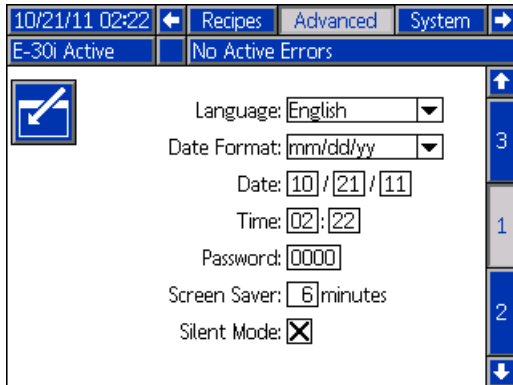

10/21/11 02:22 ← Recipes Advanced System →

E-30i Active | No Active Errors



Language: English

Date Format: mm/dd/yy

Date: 10 / 21 / 11

Time: 02 : 22

Password: 0000

Screen Saver: 6 minutes

Silent Mode:

Advanced Screen 2 — Units

Use this screen to set the temperature units, pressure units, volume units, and cycle units (pump cycles or volume).

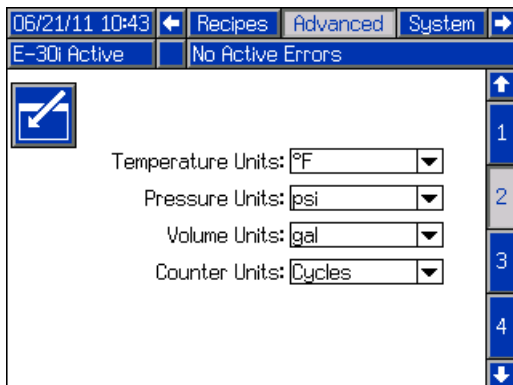

06/21/11 10:43 ← Recipes Advanced System →

E-30i Active | No Active Errors



Temperature Units: °F

Pressure Units: psi

Volume Units: gal

Counter Units: Cycles

Advanced Screen 3 — USB

Use this screen to disable USB downloads/uploads, disable USB log errors, enter the maximum number of days to download data, and how frequently USB logs are recorded. See [USB Data, page 89](#).

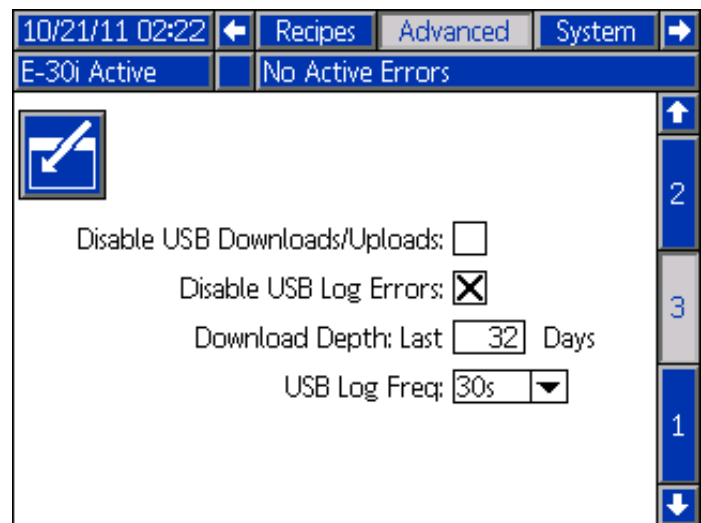

10/21/11 02:22 ← Recipes Advanced System →

E-30i Active | No Active Errors



Disable USB Downloads/Uploads:

Disable USB Log Errors:

Download Depth: Last 32 Days

USB Log Freq: 30s

Advanced Screen 4— Software

This screen displays the software part number and software version for the Advanced Display Module, Motor Control Module, High Power Temperature Control Module, Low Power Temperature Control Modules, and USB Configuration.

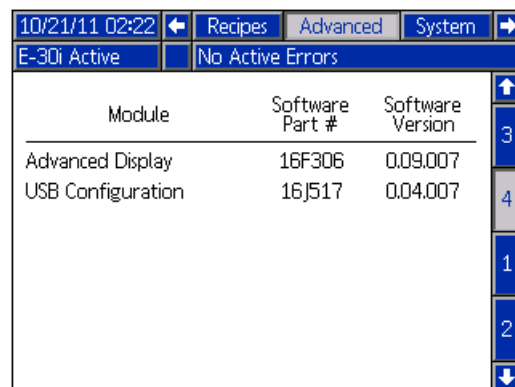

Module	Software Part #	Software Version
Advanced Display	16F306	0.09.007
USB Configuration	16J517	0.04.007

System

Use this screen to set the activation pressure for the Pressure Imbalance Alarm and Advisory, enable or disable diagnostic screens, enable drum alarms, set the maximum drum volume, enable drum alarms, and set low material alarm level.

Recipes

Use this screen to add recipes, view saved recipes, and enable or disable saved recipes. Enabled recipes can be selected at the Home Run Screen. 24 recipes can be displayed on the three recipe screens.

	A	B	Q	⊙	Enabled
	°F	°F	°F	psi	
RECIPE A	120	120	130	2000	<input checked="" type="checkbox"/>
RECIPE B	100	100	100	1500	<input checked="" type="checkbox"/>
RECIPE C	140	140	140	1750	<input checked="" type="checkbox"/>
RECIPE D	32	32	32	0	<input type="checkbox"/>
RECIPE E	32	32	32	0	<input type="checkbox"/>
RECIPE F	32	32	32	0	<input type="checkbox"/>
RECIPE G	32	32	32	0	<input type="checkbox"/>
RECIPE H	32	32	32	0	<input type="checkbox"/>

Add Recipe



1. Press and then use to select a recipe field. Press to enter a recipe name (maximum 16 characters). Press to clear the old recipe name.

2. Use to highlight the next field and use the number pad to enter a value. Press to save.

Enable or Disable Recipes

1. Press and then use to select the recipe that needs to be enabled or disabled.
2. Use to highlight the enabled check box. Press to enable or disable the recipe.

Run Mode

The ADM will start in the Run screens at the “Home” screen. Press   to navigate through the Run Mode screens. See [Run Screens Navigation Diagram, page 44](#).

From the Run screens, press



to access the Setup screens.

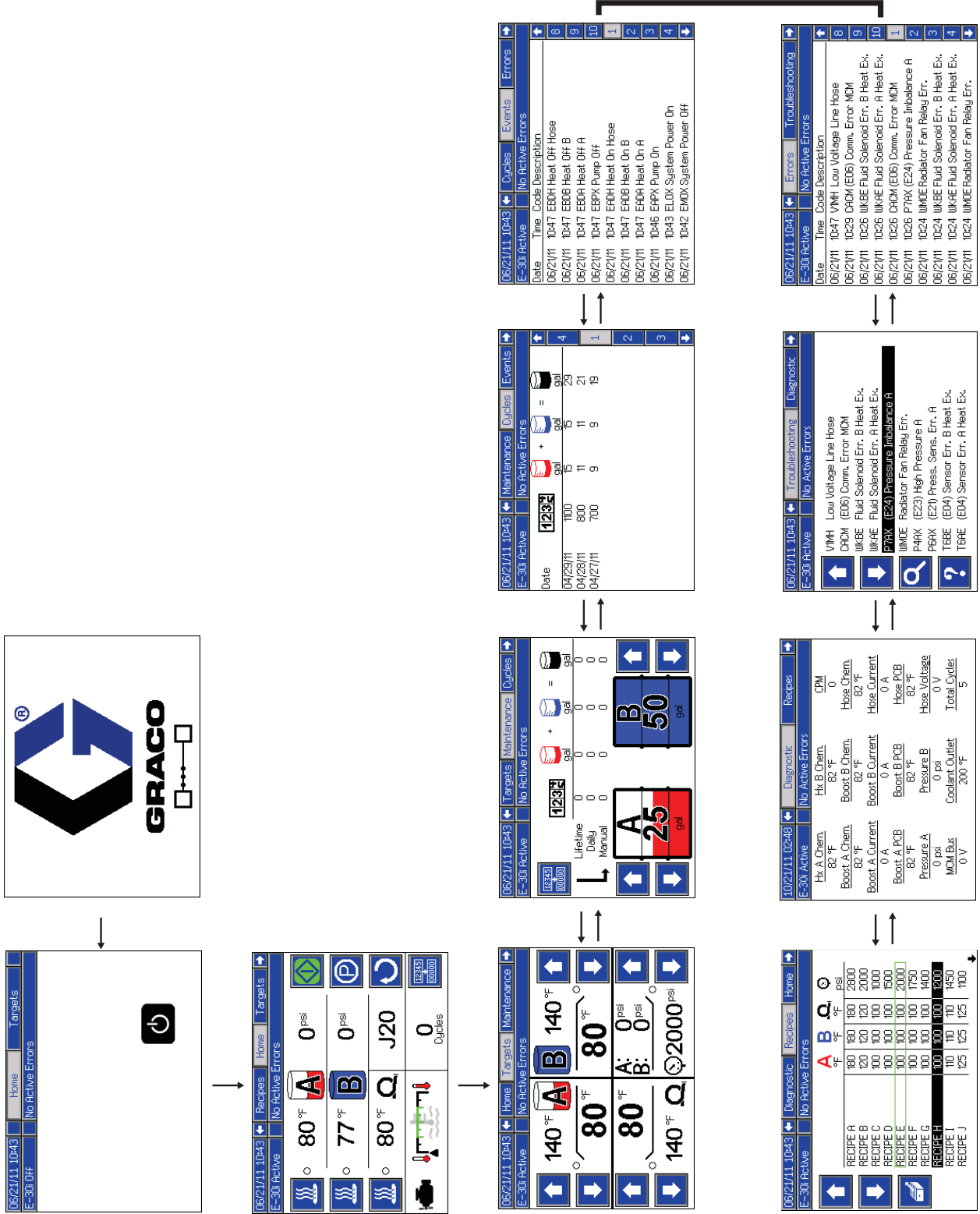

Run Screens Navigation Diagram
Figure 37

Home — System Off

This is the home screen when the system is off. This screen displays actual temperatures, actual pressures at the fluid manifold, jog speed, coolant temperature, and number of cycles.

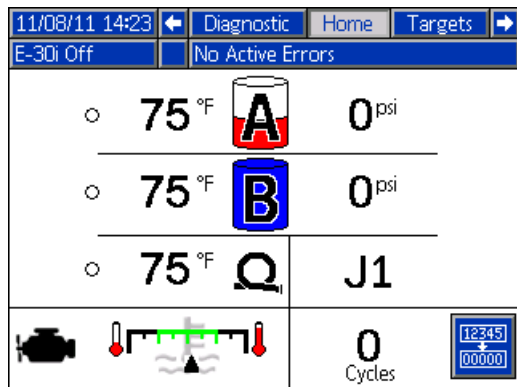

Home — System Active

When the system is active, the home screen displays actual temperature for heat zones, actual pressures at the fluid manifold, coolant temperature, jog speed, the number of cycles, along with all associated control soft keys.

Use this screen to turn on heat zones, view coolant temperature, start the proportioner, stop the proportioner, park the component A pump, enter jog mode, and clear cycles.

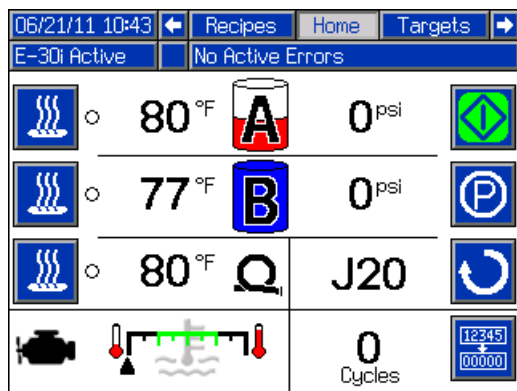

Home — System With Error

Active errors are shown in the status bar. The error code, alarm bell, and description of the error will scroll in the status bar.

1. Press to acknowledge the error.
2. See for corrective action.



Targets

Use this screen to define the setpoints for the A Component Temperature, B Component Temperature, heated hose temperature, and pressure.

Maximum A and B temperature for systems without booster heat: 140°F (60°C)

Maximum A and B temperature for systems with booster heat: 180°F (82°C)

Maximum heated hose temperature: 10°F (5°C) above the highest A or B temperature setpoint or 180°F (82°C).

Note

If the remote display module kit is used, these setpoints can be modified at the gun.

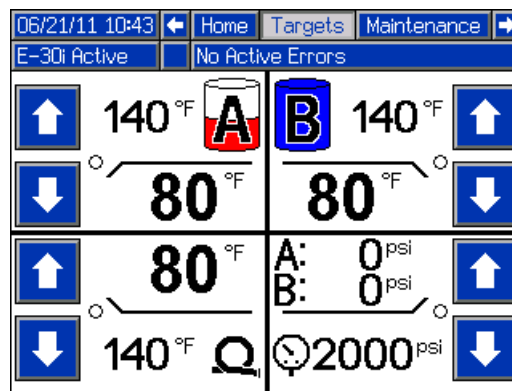

Maintenance

Use this screen to view daily and lifetime cycles or gallons that have been pumped and gallons or liters remaining in the drums.

The lifetime value is the number of pump cycles or gallons since the first time the ADM was turned on.

The daily value automatically resets at midnight.

The manual value is the counter that can be manually reset. Press  and hold to reset manual counter.

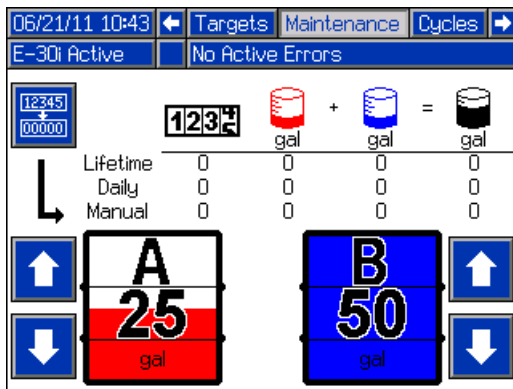

Cycles

This screen shows daily cycles and gallons that have been sprayed for the day.

All information listed on this screen can be downloaded on a USB flash drive.

Date	Cycles	Red Drum (gal)	Blue Drum (gal)	Total (gal)
04/29/11	1100	15	15	29
04/28/11	800	11	11	21
04/27/11	700	9	9	19

Events

This screen shows the date, time, event code, and description of all events that have occurred on the system. There are 10 pages, each holding 10 events. The 100 most recent events are shown. See [System Events](#)

for event code descriptions.

See [Error Codes and Troubleshooting, page 74](#) for error code descriptions.

All events and errors listed on this screen can be downloaded on a USB flash drive. To download logs, see [Download Procedure, page 91](#).

Date	Time	Code	Description
06/21/11	10:47	EBDH	Heat Off Hose
06/21/11	10:47	EBDB	Heat Off B
06/21/11	10:47	EBDA	Heat Off A
06/21/11	10:47	EBPX	Pump Off
06/21/11	10:47	EADH	Heat On Hose
06/21/11	10:47	EADB	Heat On B
06/21/11	10:47	EADA	Heat On A
06/21/11	10:46	EAPX	Pump On
06/21/11	10:43	ELOX	System Power On
06/21/11	10:42	EMOX	System Power Off

Errors

This screen shows the date, time, error code, and description of all errors that have occurred on the system.

All errors listed on this screen can be downloaded on a USB flash drive.

Date	Time	Code	Description
06/21/11	10:47	VIMH	Low Voltage Line Hose
06/21/11	10:29	CACM (E06)	Comm. Error MCM
06/21/11	10:26	WKBE	Fluid Solenoid Err. B Heat Ex.
06/21/11	10:26	WKAE	Fluid Solenoid Err. A Heat Ex.
06/21/11	10:26	CACM (E06)	Comm. Error MCM
06/21/11	10:26	P7AX (E24)	Pressure Imbalance A
06/21/11	10:24	WMOE	Radiator Fan Relay Err.
06/21/11	10:24	WKBE	Fluid Solenoid Err. B Heat Ex.
06/21/11	10:24	WKAE	Fluid Solenoid Err. A Heat Ex.
06/21/11	10:24	WMOE	Radiator Fan Relay Err.

Diagnostic

Use this screen to view information for all system components.

10/21/11 02:48		Diagnostic	Recipes
E-30i Active		No Active Errors	
<u>Hx A Chem.</u>	<u>Hx B Chem.</u>	<u>CPM</u>	
82 °F	82 °F	0	
<u>Boost A Chem.</u>	<u>Boost B Chem.</u>	<u>Hose Chem.</u>	
82 °F	82 °F	82 °F	
<u>Boost A Current</u>	<u>Boost B Current</u>	<u>Hose Current</u>	
0 A	0 A	0 A	
<u>Boost A PCB</u>	<u>Boost B PCB</u>	<u>Hose PCB</u>	
82 °F	82 °F	82 °F	
<u>Pressure A</u>	<u>Pressure B</u>	<u>Hose Voltage</u>	
0 psi	0 psi	0 V	
<u>MCM Bus</u>	<u>Coolant Outlet</u>	<u>Total Cycles</u>	
0 V	200 °F	5	

The following information is displayed:

Temperature

- Hx A Chem: Heat Exchanger A Chemical
- Hx B Chem: Heat Exchanger B Chemical
- Hose Chemical
- Booster A Chemical

- Booster B Chemical
- Booster A PCB — temperature control module temperature
- Booster B PCB — temperature control module temperature
- Hose PCB — temperature control module temperature
- Coolant Outlet

Amps

- Booster A Current
- Booster B Current
- Hose Current

Volts

- MCM Bus
- Incoming Hose Voltage (240V)

Pressure

- Pressure A — chemical
- Pressure B — chemical

Cycles

- CPM — cycles per minute
- Total Cycles

Troubleshooting

This screen displays the last ten errors that occurred on the system. Use the up and down arrows to select an error and press  to view troubleshooting information for the selected error.

Press  to access troubleshooting screen for an error code that is not listed on this screen. See [Error Codes and Troubleshooting, page 74](#), for more information on error codes.

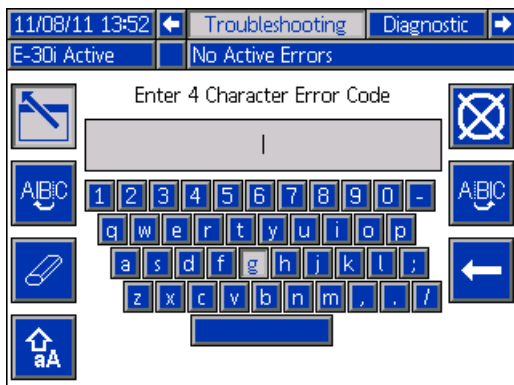
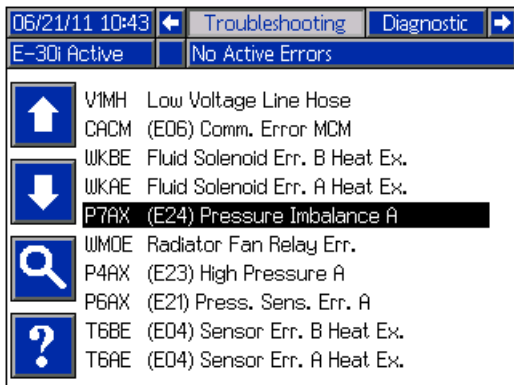

Recipes

Use this screen to select an enabled recipe. Use the up and down arrows to highlight a recipe and press  to load. The currently loaded recipe is outlined by a green box.

Note

This screen will not display if there are not any enabled recipes. To enable or disable recipes, see [Recipes Setup Screen, page 47](#).

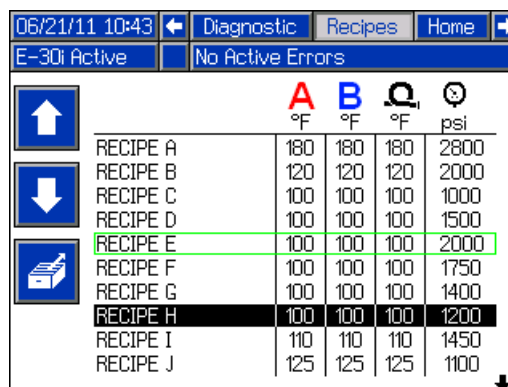

System Events

Use the table below to find a description for all system events. All events are logged in the USB log files.

Event Code				Description
E	A	C	X	Recipe Selected
E	A	D	A	Heat On A
E	A	D	B	Heat On B
E	A	D	H	Heat On Hose
E	A	P	X	Pump On
E	A	R	X	Jog On
E	A	U	X	USB Drive Inserted
E	B	0	X	ADM Red Stop Button Pressed
E	B	D	A	Heat Off A
E	B	D	B	Heat Off B
E	B	D	H	Heat Off Hose
E	B	P	X	Pump Off
E	B	R	X	Jog Off
E	B	U	X	USB Drive Removed
E	C	0	X	Setup Value Changed
E	C	D	A	A Temperature Setpoint Changed
E	C	D	B	B Temperature Setpoint Changed
E	C	D	H	Hose Temperature Setpoint Changed
E	C	D	P	Pressure Setpoint Changed
E	C	D	X	Recipe Changed
E	L	0	X	System Power On
E	M	0	X	System Power Off
E	P	0	X	Pump Parked
E	Q	U	1	System Settings Downloaded
E	Q	U	2	System Settings Uploaded
E	Q	U	3	Custom Language Downloaded
E	Q	U	4	Custom Language Uploaded
E	Q	U	5	Logs Downloaded
E	R	0	X	User Counter Reset
E	V	U	X	USB Disabled

Startup



NOTICE

Proper system setup, startup, and shutdown procedures are critical to electrical equipment reliability. The following procedures ensure steady voltage. Failure to follow these procedures will cause voltage fluctuations that can damage electrical equipment and void the warranty.

1. Check generator fuel level.

Running out of fuel will cause voltage fluctuations that can damage electrical equipment.

2. Check coolant levels.

Inspect the level of coolant inside the engine coolant expansion bottle (EB) and heat exchanger coolant expansion bottle (HB).

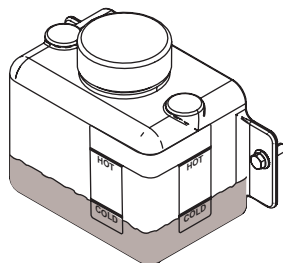

3. Check fluid inlet screens.

Before daily startup, ensure that the fluid inlet screens are clean. See [Flush Inlet Strainer Screen, page 67](#)

4. Check ISO lubrication reservoir.

Check level and condition of ISO lube daily. See [Pump Lubrication System, page 68](#).

5. Confirm main power switch is OFF before starting generator.

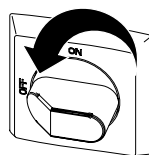

6. Start the generator.

Press start button  twice on the engine control module. The controller will automatically sequence glow plug warming and crank operations. Allow engine to reach full operating speed.

Note

Engine will not start if main power switch is in the on position.

Note

If the engine control module screen does not light up after the start button is pressed, see the system repair manual.

7. Turn main power switch ON.

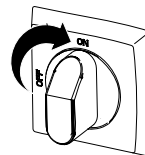

When the system is powered up by turning the main power switch (MP) to the ON position, the splash screen will display until communication and initialization is complete.



Startup

8. Check coolant color.

Use a flashlight to inspect the color of the coolant through sight glass (SG). The mesh filter should be visible inside the sight glass and the coolant should be green. If there are a lot of air bubbles, then the coolant level may be low. If the coolant is a milky color, then that indicates A or B material has likely leaked inside a heat exchanger and that the coolant needs to be drained.

- To add more coolant, see [Refill Proportioner Coolant Loop, page 70](#) and [Refill Engine Coolant Loop, page 72](#).
- To drain the coolant system, see [Drain Coolant, page 69](#).

9. Switch on the air compressor, air dryer, breathing air, and other accessories.

Complete the following steps for systems with a supplied air compressor.

- Before startup, close the main air shutoff valve (CK), desiccant air dryer inlet valve (CL), and water drain valve (CM) whenever the pressure in the air supply tank has been relieved.

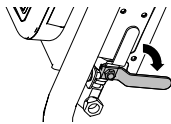

Main Air Shutoff Valve (CK)

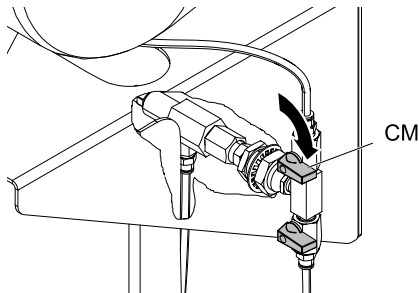
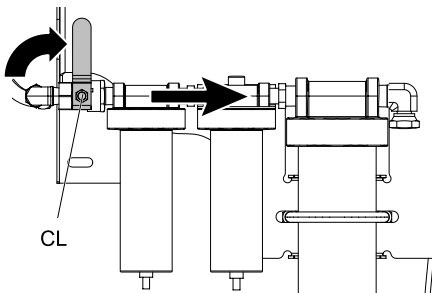

- Press start on the air compressor power box (CB). Wait until the pressure gauge (CJ) on the air supply tank reaches 30 psi.

- Open the desiccant dryer inlet valve (CL), water drain valve (CM), and the main air shutoff valve (CK).
10. During initial startup, ensure all three air regulators are turned fully counterclockwise.

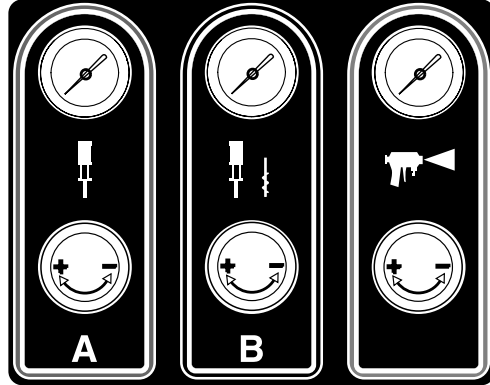

11. Open the main air shutoff valve.

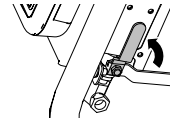

12. Slowly increase the air pressure regulator settings.

13. Load fluid with feed pumps.

- Check that all **Setup** steps are complete. See [Setup, page 33](#).
- If an agitator is used, open the agitator's air inlet valve.
- If you need to circulate fluid through the system to preheat the drum supply, see [Circulation Through Reactor, page 59](#) If you need to circulate material through the heat hose to the gun manifold, see [Circulation Through Gun Manifold, page 60](#).
- Turn both PRESSURE RELIEF/SPRAY valves (SA, SB) to SPRAY .

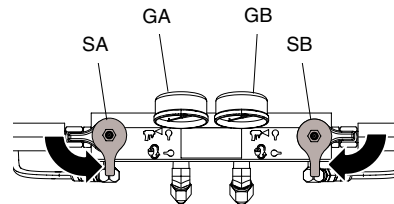

- Adjust A and B feed pump air regulators to desired air pressure, on front of proportioner, to start the feed pumps. Do not exceed 130 psi (0.2 MPa, 2 bar) to the A and B feed pumps.

- f. Open fluid inlet valves (FV). Check for leaks.

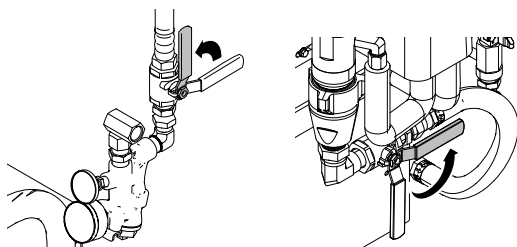

Do not mix components A and B during startup. Always provide two grounded waste containers to keep component A and component B fluids separate.				

- g. Hold gun fluid manifold over two grounded waste containers. Open fluid valves A and B until clean, air-free fluid comes from valves. Close valves.

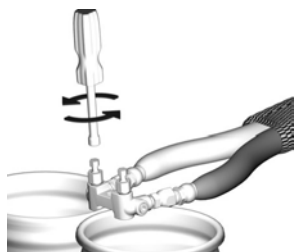

The Fusion AP gun manifold is shown.

14. Setup ADM. [Advanced Display Module \(ADM\) Operation, page 43.](#)

15. Press to turn on hose heat zone.

This equipment is used with heated fluid which can cause equipment surfaces to become very hot. To avoid severe burns:				
<ul style="list-style-type: none"> • Do not touch hot fluid or equipment. • Do not turn on hose heat without fluid in hoses. • Allow equipment to cool completely before touching it. • Wear gloves if fluid temperature exceeds 110°F (43°C). 				

Thermal expansion can cause overpressurization, resulting in equipment rupture and serious injury, including fluid injection. Do not pressurize system when preheating hose.				

16. Wait for the engine to reach operating temperature and the hose to reach setpoint temperature. The engine has reached operating temperature when the black arrow is under the green area of the temperature bar. The radiator fan will turn on when operating temperature is reached.



17. Wait for the hose to reach set point temperature or a hose overpressure condition may occur due to thermal expansion.

18. Press to turn on A and B heat zones.

Temporary Manual Hose Temperature Control

If T6DH error code appears from a break in the hose RTD cable or FTS sensor, follow the steps for temporary manual hose temperature control. Repair or replace the hose RTD cable or FTS as soon as job is finished.

1. Connect the spare RTD (15V837), shipped with the system, to the Fluid Temperature Sensor (FTS) cables (SC) at the Reactor Fluid Manifold (FM).

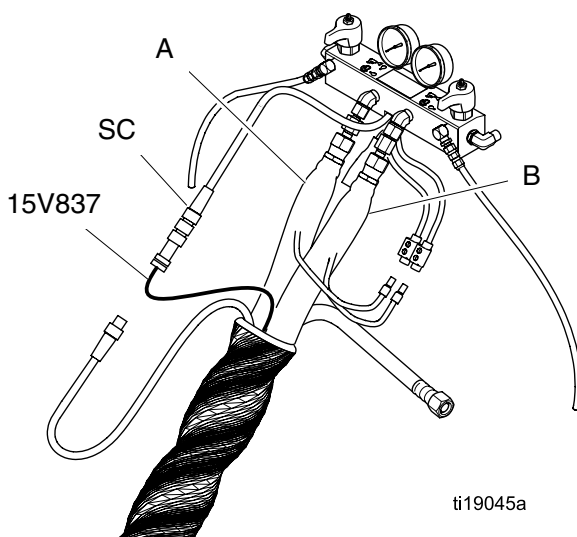

2. Insert the RTD sensor probe between the two hoses where the scuff guard ends.
3. Lower the hose temperature setpoint on the system ADM screen by (20°F (-6°C)). Push probe into the hose bundle at least 3 in. (76 mm).
4. Do not leave the RTD tip probe exposed to air or a hose overtemperature condition may occur.

NOTICE

To prevent overheating material and damaging the hoses, do not leave the spare RTD between the two hoses after the job is complete.

5. Repair or replace the hose RTD cable or FTS as soon as the job is finished.

Fluid Circulation





Circulation Through Reactor

NOTICE

Do not circulate fluid containing a blowing agent without consulting with your material supplier regarding fluid temperature limits.

To circulate through gun manifold and preheat hose, see [Circulation Through Gun Manifold, page 60](#).



1. Follow [Startup, page 55](#).

				
<p>To avoid injection injury and splashing, do not install shutoffs downstream of the PRESSURE RELIEF/SPRAY valve outlets (BA, BB). The valves function as overpressure relief valves when set to SPRAY . Lines must be open so valves can automatically relieve pressure when machine is operating.</p>				

2. See [Typical Installation, with circulation, page 13](#). Route circulation lines back to respective component A or B supply drum. Use hoses rated at the maximum working pressure of this equipment. See [Technical Specifications, page 102](#).

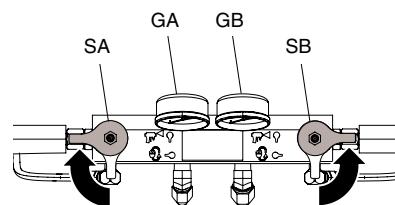
3. Set PRESSURE RELIEF/SPRAY valves (SA, SB) to PRESSURE RELIEF/CIRCULATION .



4. Set temperature targets. See [Targets, page 50](#).
5. Press  to circulate fluid in jog mode until A and B temperatures reach targets. See [Jog Mode, page 60](#) for more information about jog mode.
6. Press  to turn on the hose heat zone.
7. Turn on the A and B heat zones. Wait until the fluid inlet valve temperature gauges (FV) reach the minimum chemical temperature from the supply drums.
8. Exit jog mode.
9. Set PRESSURE RELIEF/SPRAY valves (SA, SB) to SPRAY .

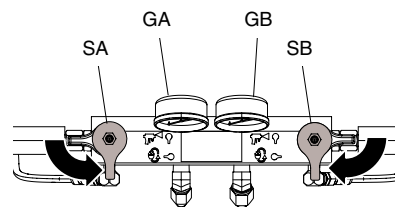

Circulation Through Gun Manifold

NOTICE

Do not circulate fluid containing a blowing agent without consulting with your material supplier regarding fluid temperature limits.

Circulating fluid through the gun manifold allows rapid preheating of the hose.

1. Install gun fluid manifold (P) on accessory circulation kit (CK). Connect high pressure circulation lines (R) to circulation manifold.

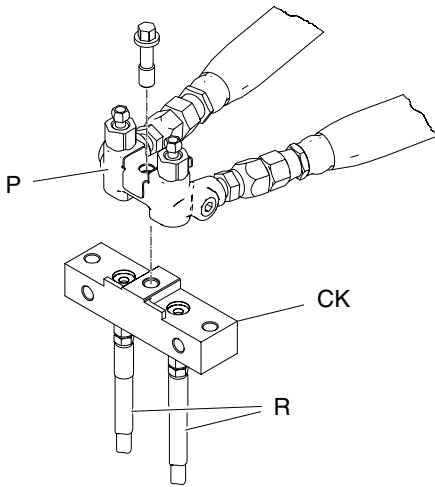



The Fusion AP gun manifold is shown.

CK	Gun	Manual
246362	Fusion AP	309818
256566	Fusion CS	313058

2. Route circulation lines back to respective component A or B supply drum. Use hoses rated at the maximum working pressure of this equipment. See [Technical Specifications, page 102](#).

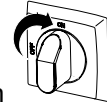
3. Follow procedures from [Startup, page 55](#).







4. Turn main power switch on
5. Set temperature targets. See [Targets, page 50](#).
6. Press  to circulate fluid in jog mode until A and B temperatures reach targets. See [Jog Mode, page 60](#) for more information about jog mode.

Jog Mode

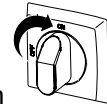
Jog mode has two purposes:



- It can speed fluid heating during circulation.
- It can ease system flushing and priming.



1. Turn main power switch on
2. Press circulate  to enter jog mode.
3. Press up or down   to change jog speed (J1 through J20).

Note

Jog speeds correlate to 3-30% of motor power, but will not operate over 700 psi (4.9 MPa, 49 bar) for either A or B.

4. Press  to start motor.
5. To stop the motor and exit jog mode press  or .

Spraying



The Fusion AP gun is shown.

1. Engage gun piston safety lock.



2. Close gun fluid inlet valves A and B.

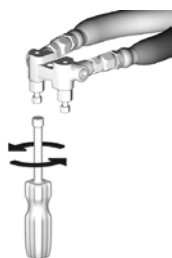

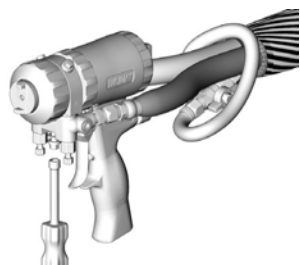

3. Attach gun fluid manifold. Connect gun air line. Open air line valve.

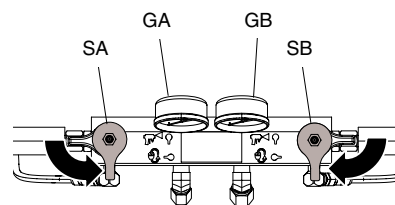

4. Adjust the gun air regulator on the proportioner control panel to desired gun air pressure. Do not exceed 130 psi (0.2 MPa, 2 bar).
5. Set PRESSURE RELIEF/SPRAY valves (SA, SB) to SPRAY .



6. Check that heat zones are on and temperatures are on target, see [Home screen, page 50](#)
7. Verify that the engine temperature is at least up to the minimum operation temperature range. The fan will start running when the engine has reached maximum temperature.
8. Press  to start motor and pumps.
9. Check fluid pressure and adjust as necessary.
10. Check fluid pressure gauges (GA, GB) to ensure proper pressure balance. If imbalanced, reduce pressure of higher component by **slightly** turning PRESSURE RELIEF/SPRAY valve for that component toward PRESSURE

RELIEF/CIRCULATION  until gauges show balanced pressures.

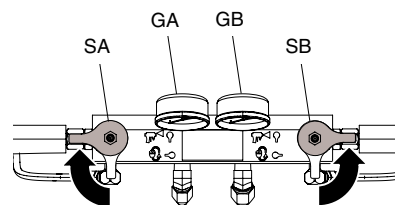

11. Instructions continue on next page.

Spraying

12. Open gun fluid inlet valves A and B.

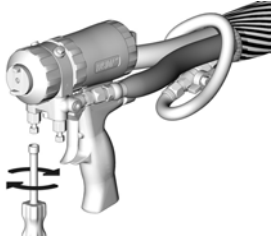

Note

On impingement guns, **never** open fluid manifold valves or trigger gun if pressures are imbalanced.

13. Disengage gun piston safety lock.



14. Test spray onto cardboard. Adjust pressure and temperature to get desired results.

15. Equipment is ready to spray.

Spray Adjustments



Flow rate, atomization, and amount of overspray are affected by four variables.

- **Fluid pressure setting.** Too little pressure results in an uneven pattern, coarse droplet size, low flow, and poor mixing. Too much pressure results in excessive overspray, high flow rates, difficult control, and excessive wear.
- **Fluid temperature.** Similar effects to fluid pressure setting. The A and B temperatures can be offset to help balance the fluid pressure.
- **Mix chamber size.** Choice of mix chamber is based on desired flow rate and fluid viscosity.
- **Clean-off air adjustment.** Too little clean-off air results in droplets building up on the front of the nozzle, and no pattern containment to control overspray. Too much clean-off air results in air-assisted atomization and excessive overspray.

Shutdown

NOTICE

Proper system setup, startup, and shutdown procedures are critical to electrical equipment reliability. The following procedures ensure steady voltage. Failure to follow these procedures will cause voltage fluctuations that can damage electrical equipment and void the warranty.

1. Press  to stop the pumps.
2. Turn off heat zones.
3. Relieve pressure. See [Pressure Relief Procedure, page 64](#).
4. Press  to park the Component A Pump.
5. Press  to deactivate the system.
6. Turn off the air compressor, air dryer, and breathing air.
7. Close the main air shutoff valve.

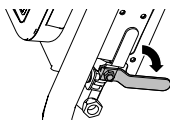

8. Turn main power switch OFF.



To prevent electric shock do not remove any shrouds or open the electrical enclosure door. 240 V is still present in the system until the engine has stopped.

9. Allow engine dwell time.



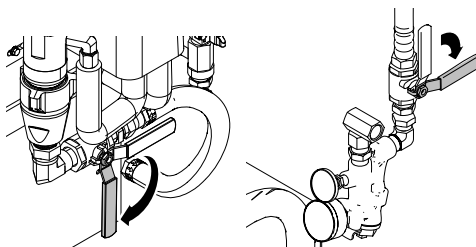

NOTICE

Allow engine dwell time, per manufacturer recommendations, prior to shutdown. Dwell time will help engine cool down after running at operating temperature for any period of time.

10. Press  on the engine control module.
11. Open air compressor bleed valve to relieve pressure and remove water from tank.
12. Close all fluid supply valves.



Pressure Relief Procedure

					
<p>This equipment stays pressurized until pressure is manually relieved. To help prevent serious injury from pressurized fluid, such as skin injection, splashing fluid and moving parts, follow the Pressure Relief Procedure when you stop spraying and before cleaning, checking, or servicing equipment.</p>					

The Fusion AP gun is shown.

1. Relieve pressure in gun and perform gun shutdown procedure. See gun manual.
2. Close gun fluid inlet valves A and B.

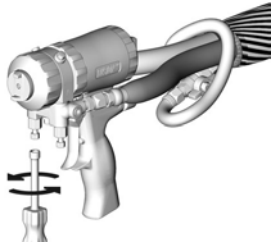

3. Shut off feed pumps and agitator, if used.

4. Route fluid to waste containers or supply tanks. Turn PRESSURE RELIEF/SPRAY valves (SA, SB) to PRESSURE RELIEF/CIRCULATION



Ensure gauges drop to 0.

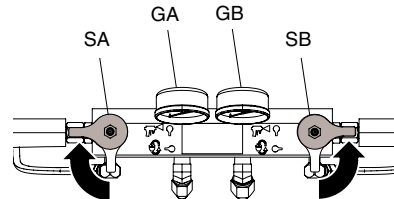



5. Engage gun piston safety lock.

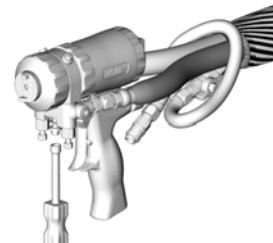

6. Disconnect gun air line and remove gun fluid manifold.



Flushing

					
<p>To prevent fire and explosion, flush equipment only in a well-ventilated area. Do not spray flammable fluids. Do not turn on heaters while flushing with flammable solvents.</p>					

- Flush out old fluid with new fluid, or flush out old fluid with a compatible solvent before introducing new fluid.
- Use the lowest possible pressure when flushing.
- All wetted parts are compatible with common solvents. Use only moisture-free solvents.

- To flush feed hoses, pumps, and heaters separately from heated hoses, set PRESSURE RELIEF/SPRAY valves (SA, SB) to PRESSURE

RELIEF/CIRCULATION  . Flush through bleed lines (N).

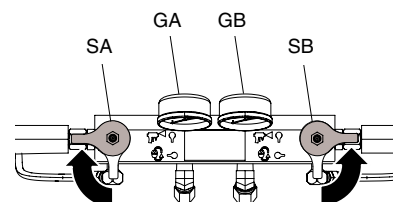

- To flush entire system, circulate through gun fluid manifold (with manifold removed from gun).
- To prevent moisture from reacting with isocyanate, always leave the system filled with a moisture-free plasticizer or oil. Do not use water. Never leave the system dry. See [Important Two-Component Material Information, page 7](#).

Maintenance



Prior to performing any maintenance procedures, follow [Pressure Relief Procedure, page 64](#).

Preventative Maintenance Schedule

The operating conditions of your particular system determine how often maintenance is required. Establish a preventive maintenance schedule by recording when and what kind of maintenance is needed, and then determine a regular schedule for checking your system.

Proportioner Maintenance

Wet Cup

Check the wet cup daily. Keep it 2/3 full with Graco Throat Seal Liquid (TSL®) or compatible solvent. Do not overtighten packing nut/wet cup.

Fluid Inlet Strainer Screens

Inspect fluid inlet strainer screens daily, see [Flush Inlet Strainer Screen, page 67](#).

Coolant Filter

Inspect filter in coolant sight glass with a flashlight, as a back light, weekly. Replace filter semi-annually. See Repair manual.

Grease Circulation Valves

Grease circulation valves (SA, SB) with Fusion grease (117773) weekly.

ISO Lubricant Level

Inspect ISO lubricant level and condition daily. Refill or replace as needed. See [Pump Lubrication System, page 68](#).

Wiring Connections

Tighten all screw-type wiring connections in the Electrical Enclosure (DB), Reactor cabinet, and air compressor control box (if supplied) monthly.

Compressor Tank Water Drain

Open the manual water drain valve weekly. See valve location on page 34. Open only when air pressure is less than 25 psi.

Dust Protection

Use clean, dry, oil-free compressed air to prevent dust buildup on control modules, control boards, fans, and motor (under shield).

Coolant Levels

Check coolant level inside both overflow tanks daily.

Flush and refill the coolant on both the engine and heat exchanger coolant loop once a year. See [Refill Proportioner Coolant Loop, page 70](#). See [Refill Engine Coolant Loop, page 72](#).

Engine Maintenance

The engine instructions that accompany your unit detail specific procedures for maintenance of the engine. Following the engine manufacturer's recommendations will extend engine work life.

Daily

- Cooling System Coolant Level — Check
- Engine Air Cleaner Service Indicator — Inspect
- Engine Oil Level — Check

Every 500 Service Hours or 1 Year

- Engine Air Cleaner Element (Dual Element) — Clean/Replace
- Engine Oil and Filter — Change
- Fuel System Filter — Replace
- Battery Voltage — Check. See [Appendix A: Engine Control Module, page 93](#).

Contact an Authorized Perkins Dealer or Distributor for replacement filter elements. Refer to Perkins engine part number GN66141N for compatible parts.

Fuel Tank

Fuel quality is critical to the performance and to the service life of the engine. Water in the fuel tank can cause excessive wear to the fuel system. See the supplied Perkins engine manual for fuel tank maintenance recommendations.

Flush Inlet Strainer Screen



The inlet strainers filter out particles that can plug the pump inlet check valves. Inspect the screens daily as part of the startup routine, and clean as required.

Isocyanate can crystallize from moisture contamination or from freezing. If the chemicals used are clean and proper storage, transfer, and operating procedures are followed, there should be minimal contamination of the A-side screen.

Note

Clean the A-side screen only during daily startup. This minimizes moisture contamination by immediately flushing out any isocyanate residue at the start of dispensing operations.

1. Close the fluid inlet valve at the pump inlet and shut off the appropriate feed pump. This prevents material from being pumped while cleaning the screen.
2. Place a container under the strainer base to catch drain off when removing the strainer plug (C).
3. Remove the screen (A) from the strainer manifold. Thoroughly flush the screen with compatible solvent and shake it dry. Inspect the screen. No more than 25% of the mesh should be restricted. If more than 25% of the mesh is blocked, replace the screen. Inspect the gasket (B) and replace as required.
4. Ensure the pipe plug (D) is screwed into the strainer plug (C). Install the strainer plug with the screen (A) and gasket (B) in place and tighten. Do not overtighten. Let the gasket make the seal.
5. Open the fluid inlet valve, ensure that there are no leaks, and wipe the equipment clean. Proceed with operation.

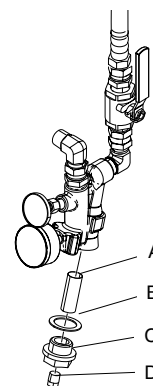

t117290b

Figure 38

Pump Lubrication System

Check the condition of the ISO pump lubricant daily. Change the lubricant if it becomes a gel, its color darkens, or it becomes diluted with isocyanate.

Gel formation is due to moisture absorption by the pump lubricant. The interval between changes depends on the environment in which the equipment is operating. The pump lubrication system minimizes exposure to moisture, but some contamination is still possible.

Lubricant discoloration is due to continual seepage of small amounts of isocyanate past the pump packings during operation. If the packings are operating properly, lubricant replacement due to discoloration should not be necessary more often than every 3 or 4 weeks.

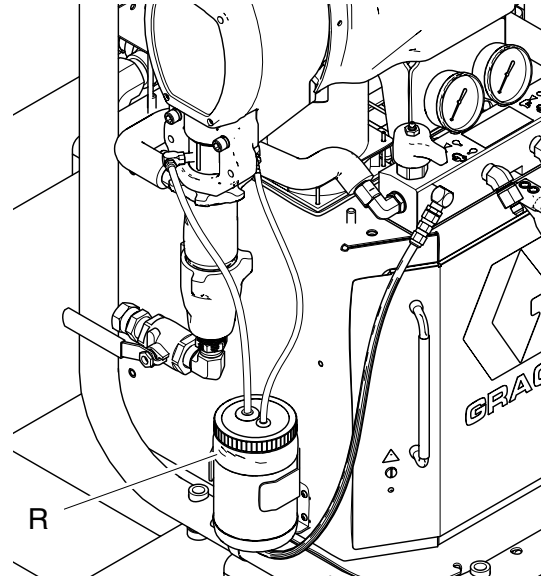

To change pump lubricant:

1. Follow [Pressure Relief Procedure, page 64](#).
2. Lift the lubricant reservoir (R) out of the bracket and remove the container from the cap. Holding the cap over a suitable container, remove the check valve and allow the lubricant to drain. Reattach the check valve to the inlet hose.
3. Drain the reservoir and flush it with clean lubricant.
4. When the reservoir is flushed clean, fill with fresh lubricant.
5. Thread the reservoir onto the cap assembly and place it in the bracket.
6. The lubrication system is ready for operation. No priming is required.



Pump Lubrication System
Figure 39

Drain Coolant

					
To avoid burns, do not perform maintenance on the coolant system until the coolant system has reached ambient temperature.					

Drain coolant from the engine and proportioner coolant loops once a year or if the coolant lines need to be disconnected, in order to install a wall between the generator and proportioner.

1. Perform [Shutdown](#), page 63.
2. Remove the cabinet door from the front of the proportioner.
3. Turn on manual valve switch (MV), located on the load center (LC), to manually open the A and B heat exchanger control valves and bypass control valve.

Note

The battery must be connected to operate valves. The load center (LC) LEDs will stay on when the manual valve switch (MV) is in the ON position.

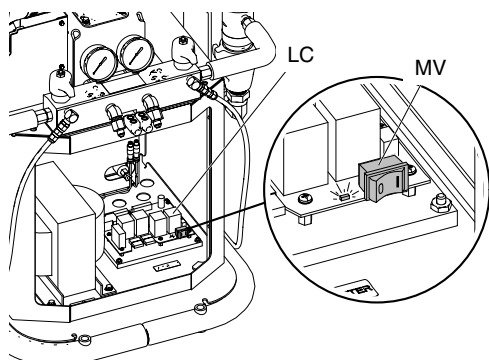
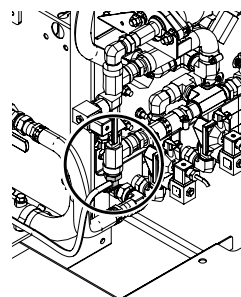

Figure 40

LED Component	LED Color
Manual valve switch (MV)	Red
A Side Control Valve	Red
B Side Control Valve	Blue
Bypass Valve	Green

4. To drain proportioner coolant loop:
 - a. Remove the proportioner coolant loop fill bottle (HF) cap.

- b. Place the other end of the drain tube in a waste container. Open the drain valve. Drain coolant until coolant is no longer visible in the sight glass.



Proportioner Coolant Loop Drain Valve
Figure 41

- c. To refill coolant loop, see [Refill Proportioner Coolant Loop](#), page 70.
5. To drain proportioner coolant loop from filter housing. Only available on Series B systems.
 - a. Remove the proportioner coolant loop fill bottle (HF).

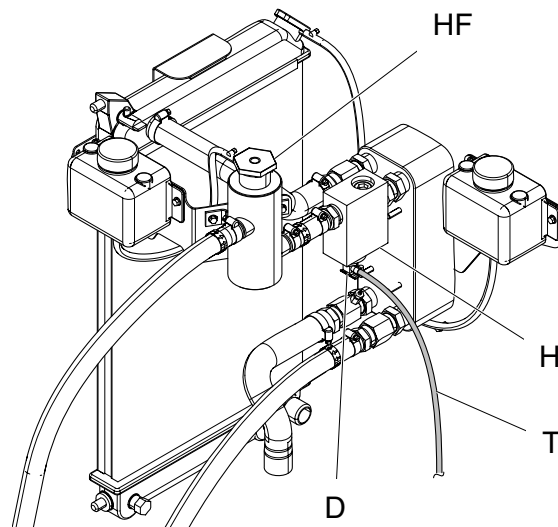

ti21730a

Filter Housing Drain Valve (D)
Figure 42

- b. Place the other end of the filter housing drain tube (T) in a waste container. Open the drain valve (D).
- c. To refill coolant loop, see [Refill Engine Coolant Loop](#), page 72.

6. To drain engine coolant loop:
 - a. Remove the engine coolant loop (RC) cap.
 - b. Remove engine guards as shown. Let the guards rest on the engine to access the drain valve.

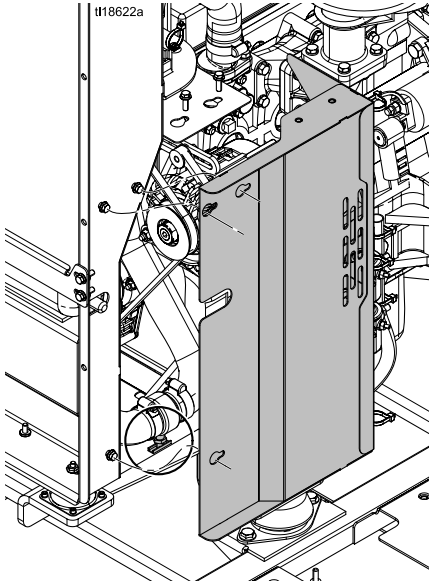

Engine Coolant Loop Drain Valve
Figure 43

- c. Place a waste container under the drain valve. Open the drain valve and drain coolant.
- d. To refill coolant loop, see [Refill Engine Coolant Loop, page 72](#).
- e. Replace engine shrouds. Torque screws to 25 ft-lbs (33.8 N·m)

Refill Proportioner Coolant Loop

Note

Air needs to be purged from the proportioner coolant loop when it is filled with new coolant or when air enters the coolant system. It takes about one full warm-up and cool-down cycle to purge air from coolant.

To avoid burns, do not perform maintenance on the coolant system until the coolant system has reached ambient temperature.					

Only use coolant solutions that are compatible with the system. See [Coolant Specifications, page 72](#).

1. Before refilling coolant loop, perform steps 1–3 from [Drain Coolant, page 69](#). Drain coolant loop if necessary.

NOTICE

Do not refill with drained coolant. Use only fresh, new coolant to avoid contaminants.

NOTICE

Do not use any “stop leak” additives to prevent plugged filters and small orifices.

NOTICE

Do not interchange the two caps between the radiator and coolant bottle. The caps have different pressure ratings that affect the overflow.

2. Remove the caps from the metal proportioner coolant loop fill bottle (HF) and expansion bottle (HB). Fill the proportioner coolant loop fill bottle (HF) to the top and add more coolant to expansion bottle (HB) until the coolant is at the cold fill line. See [Coolant Specifications, page 72](#).

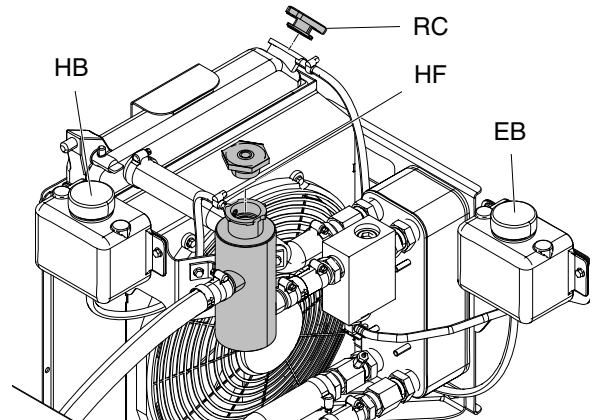

Coolant System Bottles
Figure 44

3. Replace cap. Tighten past the “safety” latch position.

4. Press start button  twice on the engine control module.

5. Turn main power switch on.



6. Inspect coolant flow in sight glass (SG) for bubbles and to verify that the coolant is flowing.

7. Inspect coolant loops for leaking fittings or valves.

8. The coolant has reached operating temperature when the radiator fan turns on. When the fan turns on, turn the main power switch OFF.



9. Press  to stop the generator.

10. After the coolant system temperature lowers to ambient temperature, refill or add coolant to the expansion bottle (HB) cold level indicator line.

11. Turn off manual valve switch (MV) to close the A and B heat exchanger control valves (VA, VB) and bypass control valve (VC).



Note

When the manual valve switch (MV) is in the OFF position, the load center (LC) LEDs only turn on when the system opens the valves.

12. If necessary, refill or add coolant to the expansion bottle (HB) cold level indicator line. See [Fig. 42](#).

Refill Engine Coolant Loop

Refill the engine coolant loop when the coolant is below the cold level line at ambient temperature.

					
To avoid burns, do not perform maintenance on the coolant system until the coolant system has reached ambient temperature.					

Only use coolant solutions that are compatible with the system. See [Coolant Specifications, page 72](#).

NOTICE
Do not refill with drained coolant. Use only fresh, new coolant to avoid contaminants.

NOTICE
Do not use any "stop leak" additives to prevent plugged filters and small orifices.

NOTICE
Do not interchange the two caps between the radiator and coolant bottle. The caps have different pressure ratings that affect the overflow.

1. Perform [Shutdown, page 63](#).
2. Remove the engine radiator coolant cap (RC) and fill until the coolant reaches the bottom of the neck. Replace cap. See [Coolant Specifications, page 72](#).
3. Remove the cap from the engine coolant loop bottle (EB) and fill until the coolant is at the hot level. Replace cap.
4. Press start button  twice on the engine control module.
5. Turn main power switch ON.



6. Inspect coolant loops for leaking fittings or valves.
7. The coolant has reached operating temperature when the radiator fan turns on. When the fan turns on, turn the main power switch OFF.

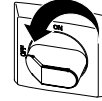

8. Press  to stop the generator.
9. Add more coolant to expansion bottle (EB) after the coolant system temperature lowers to ambient temperature. Repeat until coolant level stays at cold level when at ambient temperature. It may take a few cycles to remove all air out of coolant system.

Coolant Specifications

NOTICE
Do not refill with straight water or tap water. Changing the 50% mix ratio use of tap water will allow fittings to rust.

Only refill the coolant loops with a solution of 50% distilled or soft water and 50% green ethylene glycol antifreeze with a corrosion inhibitor. Do not use common tap water; it contains chlorides and minerals which form scale on the coolant system walls. Do not use any stop leak products. The additives in these products will clog the heat exchanger and fluid valves, decreasing system performance. Use only antifreeze that meets specification ASTM D3306-89, BS658, or AS 2108. A pre-diluted mix is recommended, such as PEAK Ready Use 50/50 Pre-Diluted.

Errors

View Errors

When an error occurs the error information screen displays the active error code and description. To diagnose the active error, see [Troubleshoot Errors, page 73](#).

The error code, alarm bell, and active errors will scroll in the status bar. For a list of the ten most recent errors see [Troubleshooting, page 74](#).



There are three types of errors that can occur. Errors are indicated on the display as well as by the light tower (optional).

Alarms are indicated by . This condition indicates a parameter critical to the process has reached a level requiring the system to stop. The alarm needs to be addressed immediately.

Deviations are indicated by . This condition indicates a parameter critical to the process has reached a level requiring attention, but not sufficient enough to stop the system at this time.

Advisories are indicated by . This condition indicates a parameter that is not immediately critical to the process. The advisory needs attention to prevent more serious issues in the future.

Troubleshoot Errors

See [Error Codes and Troubleshooting, page 74](#) for causes and solutions to each error code.

To troubleshoot the error:

1. Press the soft key for help with the active error.

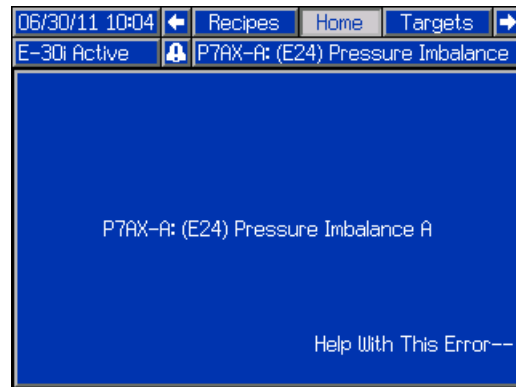

Note

Press or to return to the previously displayed screen.

2. Press to select one of following conditions that are present in the system until you are able to diagnose the error. Press to return to the previous screen.

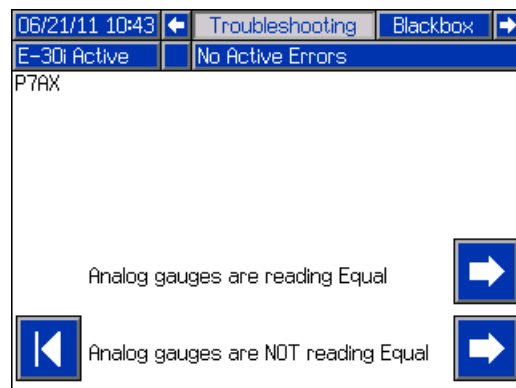

3. Select conditions that are present in the system until a cause has been identified. Press to go the troubleshooting screen that displays the ten most recent errors.

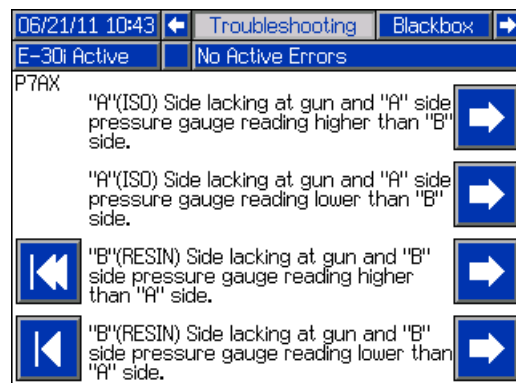

Troubleshooting

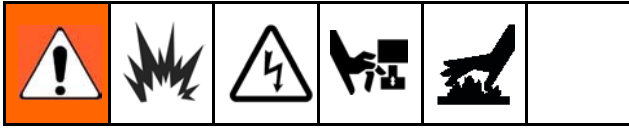

See [Errors, page 73](#) for information about errors that can occur on the system.

See [Troubleshooting, page 53](#) for the ten most recent errors that have occurred on the system. See [Troubleshoot Errors, page 73](#) to diagnose errors on the ADM that have occurred on the system.

See Error Codes and Troubleshooting for error codes, possible causes, and solutions.

Note

Error codes are stored in the error log and displayed on the Error and Troubleshooting screens on the ADM.

Error Codes and Troubleshooting

See Reactor repair manual for non-error based troubleshooting.

Error Code	Error Location	Type	Name	Cause	Solution
A1NM	MCM	ALARM	No Motor Current	Loose or bad motor or wire connection.	Check for tight motor wire termination in green connector. If loose, contact Graco distributor for rework instructions. Check for tight motor brush wire terminal screw. See system repair manual.
				Motor brushes completely worn down.	Check motor brushes and replace if needed.
				Bad MCM.	Replace MCM. See system repair manual.

Error Code	Error Location	Type	Name	Cause	Solution
A4CH	Hose	ALARM	High Relay Current Hose	Wiring problem.	Check wiring between HPTCM and contactor. Look for shorted wire between HPTCM and contactor terminals A1 and A2.
				Shorted contactor.	Measure resistance between A1 and A2 terminals. The resistance should be about 289Ω. If contactor is measuring less than 100Ω, then the contactor is shorted and should be replaced.
A4CM	MCM	ALARM	High MCM Current	MCM is drawing too much current from the system.	If problem continues replace MCM. See system repair manual.
A4DA A4DB	Boost A Boost B	ALARM	High Heater Current	Short circuit in booster heater wiring.	Check wiring for touching wires.
				Bad heater.	Measure resistance of heater(s), replace if needed. See system repair manual.
A4DH	Hose	ALARM	High Heater Current	Short circuit in hose wiring.	Check continuity of transformer windings, normal reading are about 0.2Ω on both primary and secondary. If reading is 0Ω replace transformer.
					Check for shorts between the primary winding and the support frame of the transformer.

Troubleshooting

Error Code	Error Location	Type	Name	Cause	Solution
A4NM	MCM	ALARM	High Motor Current	Short circuit of motor wiring.	Check wiring to the motor to ensure no bare wires are touching and that no wires are shorted to ground.
				Motor will not rotate.	Replace motor. See system repair manual.
				Chemical pump is stuck	Repair or replace chemical pump. See system repair manual.
A7CH	Hose	ALARM	Unexpected Relay Current	Shorted HPTCM.	Replace Module. See system repair manual.
A7DA	Boost A	ALARM	Unexpected Heater Current	Shorted LPTCM.	Replace Module. See System Repair manual.
A7DB	Boost B				
A7DH	Hose	ALARM	Unexpected Heater Current	Turned off main power switch with heaters and motor ON.	Turn off heat and motor power at ADM before turning off the main power switch.
				Turned on hose circuit breaker with hose heat on.	Turn on circuit breaker with hose heat off.
				Failed to power off after loading software.	Power off after software downloaded.
				Shorted HPTCM.	Replace Module. See system repair manual.
A8DA	Boost A	ALARM	No Heater Current	Tripped circuit breaker.	Visually check circuit breaker for a tripped condition.
A8DB	Boost B				
A8DH	Hose			Loose/broken connection.	Check heater wiring for loose wires.

Error Code	Error Location	Type	Name	Cause	Solution
CACA CACB CACH CACM CACP	Boost A Boost B Hose MCM Remote Display Module	ALARM	Communication Error	Module does not have software or dial is set to wrong position.	Insert a system token into the missing GCA module and cycle the power. Wait until the red light on the module stops flashing before removing the token. Verify the dial on the module is in the correct position: 0 for hose, A for boost A, B for boost B MCM switch: 0 for E-30i, 1 for E-XP2i
				No 24 VDC supply to module.	Green light on each module should be lit. If green light is not lit, check to make sure each CAN cable connection is tight. Verify the power supply is outputting 24 VDC. If not, replace power supply. See system repair manual.
				Loose or broken CAN cable.	Check the CAN cables running between GCA modules and tighten if needed. If the problem still persists move each cable around the connector and watch the flashing yellow light on the GCA modules. If the lights stops replace the CAN cable.
				Bad module	(CACA or CACB) Replace LPTCM. (CACH) Replace HPTCM. (CACM) Replace MCM. See system repair manual for instructions to replace modules. (CACP) Replace Remote Display Module. See Remote Display Module manual for instructions.

Troubleshooting

Error Code	Error Location	Type	Name	Cause	Solution
DADX	MCM	ALARM	Pump Runaway	Flow rate is too large	Mix chamber too large for system selected. Use mix chamber rated for system.
					Ensure the system has chemical and the feed pumps are operating correctly.
					No material in pumps. Verify pumps are supplying chemical. If necessary, replace or refill drums.
					Inlet ball valves are closed. Open ball valves.
DE0X	MCM	ALARM	Pump Cycle Switch Fault	Faulty or missing cycle switch.	Check wiring between cycle switch and MCM port 6.
F9DX	MCM	ALARM	Pressure Flow Cutback	Mix chamber is too large for the set pressure.	Reference the pressure flow curves and select a tip size that is the correct size for the set pressure. See Performance Charts, page 99 .
H1MH	Hose	ALARM	Low Line Frequency	Line frequency is below 55 Hz.	Check frequency. If out of tolerance, see supplied 120/240V alternator manual for repair instructions.
H4MH	Hose	ALARM	High Line Frequency	Line frequency is above 65 Hz.	Check frequency. If out of tolerance, see supplied 120/240V alternator manual for repair instructions.
K8NM	MCM	ALARM	Locked Rotor	Locked rotor.	Replace motor. See system repair manual.
				Chemical pump is stuck.	Repair or replace pump. See system repair manual.
L1AX	ADM	ALARM	Low Chemical Level A	Tanks low on material.	Fill tanks with material.
L1BX			Low Chemical Level B		

Error Code	Error Location	Type	Name	Cause	Solution
MBN0	MCM	ADVISORY	Motor Brush Wear	Brushes have worn down and need replacing.	Replace Brushes. See system repair manual.
MMUX	USB	ADVISORY	USB Log Full	USB logs have reached a level where data loss will occur if logs are not downloaded.	Use a USB drive and download all logs.
P4AX P4BX	MCM	ALARM	Over Pressure A Over Pressure B	System pressurized before allowing heat to reach setpoint.	Turn on the heat and allow the hose to reach the setpoint before turning on the pumps.
				Bad pressure transducer.	Verify the ADM pressure reading the analog gauges at the manifold. Replace transducers if they do not match. See system repair manual.
				E-XP2i system configured as E-30i.	Ensure rotary switch on MCM is set to position 0 for E-30i.
P6AX P6BX	MCM	ALARM	Pressure Transducer Fault A Pressure Transducer Fault B	Loose/bad connection.	Check to ensure the pressure transducer is properly installed and all wires are properly connected.
				Bad sensor.	Check if the error follows the transducer. Disconnect transducer cable from #8 and #9 connectors on MCM. Reverse A and B connections and check if the error follows. If the error follows the transducer, replace the pressure transducer. See system repair manual. If the error does not follow, replace MCM. See system repair manual.

Troubleshooting

Error Code	Error Position	Type	Name	Cause	Solution
P7AX P7BX	MCM	ALARM	Pressure Imbalance A High (P7AX) Pressure Imbalance B High (P7BX)	Pressure difference between A and B material is greater than the defined value.	Ensure the material flow is equally restricted on both material lines.
				Pressure imbalance is defined too low.	Ensure that the pressure imbalance value, on the System Setup screen, is at an acceptable maximum pressure to prevent unnecessary alarms and abort dispenses.
				Out of material.	Fill tanks with material.
				Fluid leaking from heater inlet rupture disk.	Check if heater and PRESSURE RELIEF/SPRAY valve (SA or SB) are plugged. Clear. Replace rupture disk. Do not replace with a pipe plug.
				Feed system defective.	Check feed pump and hoses for blockage. Check that the feed pumps have the correct air pressure.
P0AX	MCM	ADVISORY	Pressure Imbalance A High	See P7AX.	
P0BX	MCM	ADVISORY	Pressure Imbalance B High	See P7BX.	
T1DE	Engine Heat Exchanger	ALARM	Low Temperature Coolant Outlet	Radiator fan will not stop.	Replace fan relay. See system repair manual.
				Engine thermostat is stuck closed.	Replace thermostat. See Perkins dealer.

Error Code	Error Position	Type	Name	Cause	Solution
T2AE T2BE	Heat Exchanger	DEVIATION	Low Temperature Hx A Low Temperature Hx B	Recirculating material to heat with drum feed pumps only.	Recirculate material using Jog mode for heat exchanger heating.
				Coolant circulation pump not working.	Check for 240 VAC on pump. If there is the correct voltage, replace circulation pump. See system repair manual.
				Air lock in circulation pump.	Check for coolant flow in sight glass.
				Loose or incorrect wiring connections.	See wiring schematics, in the system repair manual, and verify coolant valve connections. Check coolant valve harness and verify voltage is 11–13 volts at coolant valve connectors.
				No voltage to coil of valve.	<p>Turn on the manual valve switch (MV), on the load center (PE), to manually turn on the solenoids and see if the temperature rises. If not, check voltage output on J6 connector on the load center and ensure the LEDs are on. See load center wiring in system repair manual.</p> <p>Follow Load Center Diagnostics instructions in system repair manual. If necessary, replace the load center board.</p> <p>If voltage is present, measure the resistance of the coil, it should be approximately 12.5 Ω, if coil is open replace coil.</p> <p>If voltage is present, test the coil with screwdriver. The screwdriver should magnetically stick inside the coil. If screwdriver sticks, then the coil is good. Replace the plunger on valve or replace the complete valve assembly. See system repair manual.</p>

Troubleshooting

Error Code	Error Position	Type	Name	Cause	Solution
T2DA T2DB	Boost A Boost B	ALARM	Low Chemical Temperature	Flow is too high at current setpoint. Bad heater(s)	Use a smaller mix chamber that is rated for the unit in use. Confirm resistance of heater is 23–26.5 ohms. Replace if OL/open loop.
T2DH	Hose	ALARM	Low Chemical Temperature	Cold chemical in unheated portion of system passed hose FTS at startup.	Recirculate heated chemical back to drum in cold conditions before startup.
T2DE	Heat Exchanger	ADVISORY	Low Temperature Coolant Outlet	Radiator fan will not stop. Engine thermostat is stuck open.	Replace fan relay. See system repair manual. Replace thermostat. See Perkins distributor to replace.
T3NM	MCM	ADVISORY	High Motor Temperature	Motor is operating outside of pressure flow curve. The system is running at a lower setpoint to preserve motor life.	Run the system at a lower duty cycle or with a smaller mix chamber. See Performance Charts, page 99 .
T4AE T4BE	Heat Exchanger	ALARM	High Chemical Temperature Hx A (T4AE) High Chemical Temperature Hx B (T4BE)	Manual valve switch (MV) on load center board is in the ON position. A or B side control valve solenoid is stuck in the open position. Debris in valve diaphragm or plunger preventing spring-loaded closed function. Short on load center board. If the blue and red LEDs are on while the heat is off, then the load center board is bad. (T4BE only) J6 connector on load center “Heat Valves” location is not centered. A and B heat exchanger RTD cables cross-connected to splitter cable.	Open cabinet cover and turn switch to the OFF position. Disconnect connector from valve solenoid coil. If temperature does not decrease, rebuild solenoid. See Load Center Diagnostics in the system repair manual. Reconnect J6 connector on load center in centered location. See System Repair Manual for correct connection.

Error Code	Error Position	Type	Name	Cause	Solution
T4CA T4CB T4CH	Boost A Boost B Hose	ALARM	(T4CA or T4CB) LPTCM Over Temperature (T4CH) HPTCM Over Temperature	Cooling fan not operating. Overheated module.	If fan is not working check wiring between CB03 and fan. If wiring is good, replace fan. Turn controller off. Wait a few minutes. If the condition does not clear or regenerates consistently, replace module.
T4CM	MCM	ALARM	High MCM Temperature	High ambient temperature.	Ensure ambient temperature is below 120°F(48°C) before using the system.
				Overheated control module.	Stop the pumps. Wait a few minutes. If the condition does not clear or regenerates consistently, replace MCM. See System Repair manual.
T4DA T4DB	Boost A Boost B	ALARM	High Chemical Temperature	Bad RTD or bad RTD placement against heater rod.	Swap A and B heater volec cables and RTD cables and see if issue follows. If so, replace RTD.
				Bad Low Power Temperature Control Module.	Swap the A and B LPTCMs and see if the issue follows the module. If so replace LPTCM. See system repair manual.
T4DE	Heat Exchanger	ALARM	High Temperature Coolant Outlet	Broken Fan.	Check fan relay (K4) and fuse (30 Amp ATO "F3") on load center board. Replace if needed.
				Plugged radiator.	Replace if needed.
				High ambient temperature.	Ensure ambient temperature is below 120°F(48°C) before using the system.

Troubleshooting

Error Code	Error Position	Type	Name	Cause	Solution
T4DH	Hose	ALARM	High Chemical Temperature	Hose portion exposed to an excessive heat source, like hot sun or coiled hose, can pass fluid more than 27°F (15°C) over temperature setting to the FTS.	Shade exposed hose from hot sun or expose FTS to same environment when at rest. Uncoil entire hose before heating to avoid self-heating.
				Bad High Power Temperature Control Module.	Replace HPTCM. See system repair manual.
T4NM	MCM	ALARM	High Motor Temperature	Cooling fans are not operating properly.	Ensure ambient temperature is less than 120°F(48°C). Check to see that the fans are moving. Measure voltage to fans. There should be 240 VAC. If no voltage is measured, check wiring between fan and circuit breaker CB03. If the fans have voltage but are not moving, replace fan. Use an air hose to blow out around the fan housings and remove any built-up debris.
				Bad electric motor.	Replace electric motor. See System Repair manual.

Error Code	Error Position	Type	Name	Cause	Solution
T6AE	Heat Exchanger A	ALARM	RTD Fault	Broken or loose RTD cable or connection.	Check all wiring and connection to RTD.
T6BE	Heat Exchanger B			Bad RTD.	Switch the RTD with another and see if the error message follows the RTD. Replace RTD if the error follows the RTD. See system repair manual for instructions.
T6DA	Boost A				
T6DB	Boost B				
T6DE	Engine Heat Exchanger				
T6DH	Hose	ALARM	RTD Cable or FTS Fault	Broken RTD cable in hose or bad FTS.	Expose each hose RTD connection to check and retighten any loose connector. Measure hose RTD cable and FTS continuity. See system repair manual. Order RTD Test Kit 24N365 for measurement. See Temporary Manual Hose Temperature Control, page 58 , to finish job until repair can be completed.

Troubleshooting

Error Code	Error Position	Type	Name	Cause	Solution
T8AE T8BE	Heat Exchanger	ALARM	Temperature Not Rising Hx A (T8AE) Temperature Not Rising Hx B (T8BE)	<p>Low chemical supply temperature.</p> <p>System stored below 20°F(-7°C) causing slow control valve operation.</p> <p>Plugged filter in sight glass. Indicated by consistent low A and B temperature alarms.</p> <p>Coolant debris stuck in valve pilot hole or passages.</p> <p>No coolant flow</p> <p>(T8AE only) J6 connector on load center "Heat Valves" location is not centered.</p> <p>Bad valve solenoid coil.</p> <p>Valve solenoid not getting 12 VDC electrical signal.</p> <p>Bad load center.</p> <p>A and B heat exchanger RTD cables cross-connected to splitter cable.</p>	<p>Recirculate heated chemical back to drum in cold conditions before spraying. Chemical below 32°F(0°C) at startup.</p> <p>Ensure ambient temperature is above 20°F(-7°C).</p> <p>Clean or replace filter. See system repair manual.</p> <p>Inspect and clean control valve. Repair or replace if necessary. See system repair manual.</p> <p>Check coolant level. Check for coolant flow in sight glass.</p> <p>Ensure that the circulation pump has 240 VAC. If not, replace the circulation pump. See system repair manual.</p> <p>Reconnect J6 connector on load center in centered location.</p> <p>Turn on the manual valve switch (MV), on the load center, and see if the valve solenoid shifts. For coolant valve LED identification, see system repair manual. If solenoid does not shift, replace solenoid coil. See system repair manual.</p> <p>Verify 12 VDC signal is at the valve solenoid coil connector. All three valves are normally closed with power removed. See system repair manual for valve wiring harness identification diagram.</p> <p>Red, blue, and green LEDs should light up on load center board. If not, replace load center. See system repair manual.</p> <p>See System Repair Manual for correct connection.</p>

Error Code	Error Position	Type	Name	Cause	Solution
T8DA T8DB	Boost A Boost B	ALARM	Temperature Not Rising	Bad heater rod (boost). Low chemical supply temperature. Bad heated hose.	Measure resistance, 23 – 26 Ω, of heater rod, replace if reading open. Recirculate heated chemical back to drum in cold conditions before spraying chemical below 32°F(0°C) at startup. Use Jog Mode for heat exchanger heating. Measure hose resistance, replace if reading open.
T8DH	Hose	ALARM	Temperature Not Rising	Started spraying before engine and hose reached operating temperature. Low chemical supply temperature.	Wait until operating temperatures have been reached on engine and hose before spraying. Recirculate heated chemical back to drum in cold conditions before spraying. Chemical below 32°F(0°C) at startup.
V1CM	MCM	ALARM	Bus Under Voltage	Tripped MCM circuit breaker (CB02).	Visually check circuit breaker for a tripped condition. If Diagnostic screen is enabled, MCM Bus 14 V indicates normal voltage and 1 V indicates failed MCM.
V1MH	Hose	ALARM	Low Line Voltage	Loose or bad connection. Low generator line voltage High auxiliary inrush current.	Check wiring for loose wires. Measure voltage across main power switch (CT01). Voltage should measure between 190 and 264 VAC. Ensure compressor or air dryer are setup to be continuous run and sized according to manual.
V4CM V4MH	MCM Hose	ALARM ALARM	Bus Overvoltage High Line Voltage	Incoming line voltage is too high.	Measure voltage across main power switch (CT01). Voltage should measure between 190 and 264 VAC. If voltage is too high, see supplied alternator manual for generator specifications and repair.
WBNM	MCM	ALARM	Motor Sensor Fault	Bad connection between MCM (Port 10) and brush wear/over temperature board. Bad brush wear/over temperature board.	Check connection and cables. Replace Motor. See system repair manual.

Troubleshooting

Error Code	Error Position	Type	Name	Cause	Solution
WMCE	MCM	ALARM	Load Center Fault	Bad Connection between MCM (Port 2) and load center board.	Check connection and cables.
				Bad load center.	Replace load center. See System Repair manual.
WSCX	ADM	ADVISORY	Invalid CAN Configuration	Duplicate node on CAN network.	Verify LPTCM are set to A and B.
WSUX	USB	ADVISORY	USB Invalid Configuration	A valid configuration file can't be found for the USB.	Insert a system token into the ADM and cycle the power. Wait until the lights on USB port stop flashing before removing the token.
				Bad ADM.	Replace ADM. See System Repair manual.
WXUD	ADM	ADVISORY	USB Download Error	Log download failed.	Backup and reformat the USB drive. Retry download.
WXUU	ADM	ADVISORY	USB Upload Error	Custom language file failed to upload	Perform normal USB download and use the new disptext.txt file to upload the custom language.
WX00	MCM	ALARM	External Input	The alarm external input has been driven low.	An active alarm is being generated by the external trigger. If the external alarm is not configured check for a short in the wiring going to MCM port 7, pins 1 and 3.

USB Data

USB Logs

Note

The ADM can read/write to FAT (File Allocation Table) storage devices. NTFS, used by 32 GB or greater storage devices, is not supported.

During operation, the ADM stores system and performance related information to memory in the form of log files. The ADM maintains four log files:

- Event Log
- Job Log
- Daily Log
- System Software Log
- Blackbox Log

Follow [Download Procedure, page 91](#), to retrieve log files.

Each time a USB flash drive is inserted into the ADM USB port, a new folder named DATAxxxx is created. The number at the end of the folder name increases each time a USB flash drive is inserted and data is downloaded or uploaded.

Event Log

The event log file name is 1–EVENT.CSV and is stored in the DATAxxxx folder.

The event log maintains a record of the last 49,182 events and errors. Each event record contains:

- Date of event code
- Time of event code
- Event code
- Event type
- Action taken
- Event Description

Event codes include both error codes (alarms, deviations, and advisories) and record only events.

Actions Taken includes setting and clearing event conditions by the system, and acknowledging error conditions by the user.

Job Log

The job log file name is 2–JOB.CSV and is stored in the DATAxxxx folder.

The job log maintains a record of data points based on the USB Log Frequency defined in the Setup screens. The ADM stores the last 415,413 data points for download. See [Setup - Advanced Screen 3 — USB, page 46](#), for information on setting the Download Depth and USB Log Frequency.

- Data point date
- Data point time
- A side heat exchanger temperature
- A side boost heater temperature
- B side heat exchanger temperature
- B side boost heater temperature
- Hose temperature
- Engine coolant temperature
- A side temperature setpoint
- B side temperature setpoint
- Hose temperature setpoint
- A side pressure
- B side pressure
- Pressure setpoint
- System lifetime pump cycle counts
- Pressure, volume, and temperature units

Daily Log

The daily log file name is 3-DAILY.CSV and is stored in the DATAxxxx folder.

The daily log maintains a record of the total cycle and volume sprayed on any day that the system is powered up. The volume units will be the same units that were used in the Job Log.

The following data is stored in this file:

- Date that material was sprayed
- Time — unused column
- Total pump cycle count for day
- Total volume sprayed for day

System Software Log

The system software file name is 4-SYSTEM.CSV and is stored in the DATAxxxx folder.

The system software log lists the following:

- Date log was created
- Time log was created
- Component name
- Software version loaded on the above component

Blackbox Log File

The black box file name is 5-BLACKB.CSV and is stored in the DATAxxxx folder.

The Blackbox log maintains a record of how the system runs and the features that are used. This log will help Graco troubleshoot system errors.

System Configuration Settings

The system configuration settings file name is SETTINGS.TXT and is stored in the DOWNLOAD folder.

A system configuration settings file automatically downloads each time a USB flash drive is inserted into the ADM. Use this file to back up system settings for future recovery or to easily replicate settings across multiple systems. Refer to the [Upload Procedure, page 92](#) for instructions on how to use this file.

Download Procedure

Note

System configuration setting files and custom language files can be modified if the files are in the UPLOAD folder of the USB flash drive. See System Configuration Settings File, Custom Language File, and Upload Procedure sections.

Note

If needed, set the number of days to download on the Advanced Setup Screen 3–USB in the ADM. USB log frequency can only be changed before logging occurs.

1. Insert USB flash drive into USB port.
2. The menu bar and USB indicator lights “USB Busy” to indicate that the USB is downloading files. USB activity is complete when the “USB Busy” screen prompt disappears or the flash drive LED stops flashing.

Note

Normal system spraying can continue while download is in progress.
3. Remove USB flash drive from USB port.
4. Insert USB flash drive into USB port of computer.
5. The USB flash drive window automatically opens. If it does not, open USB flash drive from within Windows® Explorer.
6. Open GRACO folder.
7. Open the system folder. If downloading data from more than one system, there will be more than one folder. Each folder is labeled with the corresponding serial number of the ADM (The serial number is on the back of the ADM.)
8. Open DOWNLOAD folder.

9. Open DATAxxxx folder.
10. Open DATAxxxx folder labeled with the highest number. The highest number indicates the most recent data download.
11. Open log file. Log files open in Microsoft® Excel by default as long as the program is installed. However, they can also be opened in any text editor or Microsoft® Word.

Note

All USB logs are saved in Unicode (UTF-16) format. If opening the log file in Microsoft Word, select Unicode encoding.

Custom Language File

The custom language file name is DISPTXT.TXT and is stored in the DOWNLOAD folder.

A custom language file automatically downloads each time a USB flash drive is inserted into the ADM. If desired, use this file to create a user-defined set of custom language strings to be displayed within the ADM.

The system is able to display the following Unicode characters. For characters outside of this set, the system will display the Unicode replacement character, which appears as a white question mark inside of a black diamond.

- U+0020 - U+007E (Basic Latin)
- U+00A1 - U+00FF (Latin-1 Supplement)
- U+0100 - U+017F (Latin Extended-A)
- U+0386 - U+03CE (Greek)
- U+0400 - U+045F (Cyrillic)

Create Custom Language Strings

The custom language file is a tab-delimited text file that contains two columns. The first column consists of a list of strings in the language selected at the time of download. The second column can be used to enter the custom language strings. If a custom language was previously installed, this column contains the custom strings. Otherwise the second column is blank.

Modify the second column of the custom language file as needed and the follow [Upload Procedure, page 92](#) , to install the file.

The format of the custom language file is critical. The following rules must be followed in order for the installation process to succeed.

- Define a custom string for each row in the second column.

Note

If the custom language file is used, you must define a custom string for each entry in the DISPTXT.TXT file. Blank second-column fields will be displayed blank on the ADM.

- The file name must be DISPTXT.TXT.
- The file format must be a tab-delimited text file using Unicode (UTF-16) character representation.
- The file must contain only two columns, with columns separated by a single tab character.
- Do not add or remove rows to the file.
- Do not change the order of the rows.

Upload Procedure

Use this procedure to install a system configuration file and/or a custom language file.

1. If necessary, follow the **Download Procedure** to automatically generate the proper folder structure on the USB flash drive.
2. Insert USB flash drive into USB port of computer.
3. The USB flash drive window automatically opens. If it does not, open USB flash drive from within Windows Explorer.
4. Open GRACO folder.
5. Open the system folder. If working with more than one system, there will be more than one folder within the GRACO folder. Each folder is labeled with the corresponding serial number of the ADM. (The serial number is on the back of the module.)
6. If installing the system configuration settings file, place SETTINGS.TXT file into the UPLOAD folder.
7. If installing the custom language file, place DISPTXT.TXT file into the UPLOAD folder.
8. Remove USB flash drive from the computer.
9. Install USB flash drive into the ADM USB port.
10. The menu bar and USB indicator lights indicate that the USB is downloading files. Wait for USB activity to complete.
11. Remove USB flash drive from USB port.

Note



If the custom language file was installed, users can now select the new language from the Language drop-down menu in [Advanced Screen 1 — General, page 46](#).

Appendix A: Engine Control Module

Run Screens

There are seven run screens on the engine control module:



- Line-to-neutral voltage
- Line-to-line voltage
- Frequency
- Engine Speed
- Engine lifetime counter
- Battery voltage

Press  to scroll through the run screens. Press  to enter the Information screens.

Run Screen Layout

Inst Icon	Instrumentation	Units	Alarm Icon
			Mode Icon

Information Screens

From the Run Screen, press  to enter the information screens. Press  to scroll through the last five generator events.





Press  to return to the Run Screens.

Information Screen Layout

	Time of Event (Engine Run Hours)	Units	Alarm Icon
Event #			Mode Icon





Mode Icons

An icon is displayed in the mode icon area of the display to indicate what mode the unit is currently in.

Icon	Description	Details
	Stopped	Engine is at rest and the unit is in stop mode.
	Auto	Engine is at rest and the unit is in auto mode.
	Manual	Engine is at rest and the unit is in manual run mode.
	Timer animation	Engine is starting up.
	Running animation	Engine is running.

Instrumentation Icons

A small icon is displayed in the instrumentation icon area to indicate what value is currently being displayed.





Icon	Description	Details
	Generator	Generator voltage and frequency screen
	Engine Speed	Engine speed screen
	Engine Lifetime Counter	Hours run
	Event Log	Event is being displayed.
	Unit Time	Unused feature

Alarms

There are two types of alarms that can occur on the system. Alarms are indicated by an icon the Run and Information screens.







Warning

When present on system, a warning alarm will not stop the generator.

Icon	Description	Details
	Battery High Voltage	The DC Supply has risen above the high volts setting level for the duration of the high battery volts timer.
	Battery Low Voltage	The DC Supply has fallen below the low volts setting level for the duration of the low battery volts timer.
	Fail To Stop	The module detected a condition that indicates that the engine is running when it has been instructed to stop.
	Flexible Sensor	The flexible sensor warning alarm has been triggered.

Shutdown

When present on system, a shutdown alarm will stop the generator. Clear the alarm and remove the fault. Then press the stop button to reset the module. See the information screen to see the latest alarm.

Icon	Description	Details
	Fail To Start	The engine has not fired after the preset number of start attempts.
	Generator High Voltage Shutdown	The generator output voltage has risen above the preset level.
	Generator Low Voltage Shutdown	The generator output voltage has fallen below the preset level.
	High Coolant Temperature Shutdown	The module detects that the engine coolant temperature has exceeded the high engine temperature shutdown setting after the Safety On timer has expired.
	Low Oil Pressure Shutdown	The engine oil pressure has fallen below the low oil pressure trip setting level after the Safety On timer has expired.
	Over Frequency Shutdown	The generator output frequency has risen above the preset level.
	Under Frequency Shutdown	The generator output frequency has fallen below the preset level.

Dimensions

Dimensions

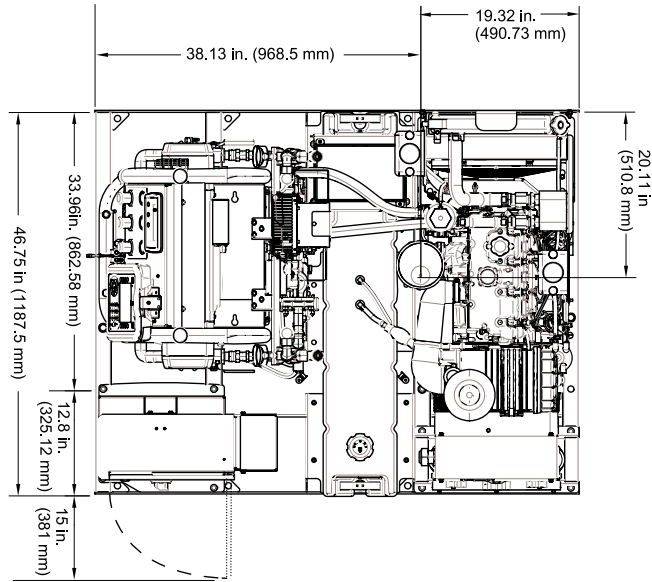

Top View
Figure 45

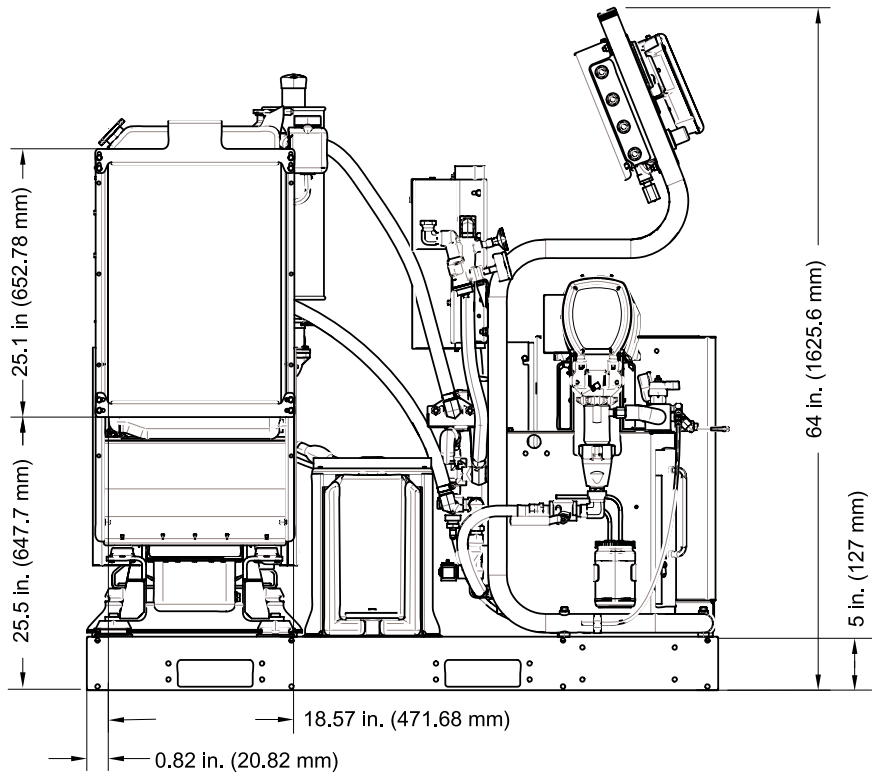

Side View
Figure 46

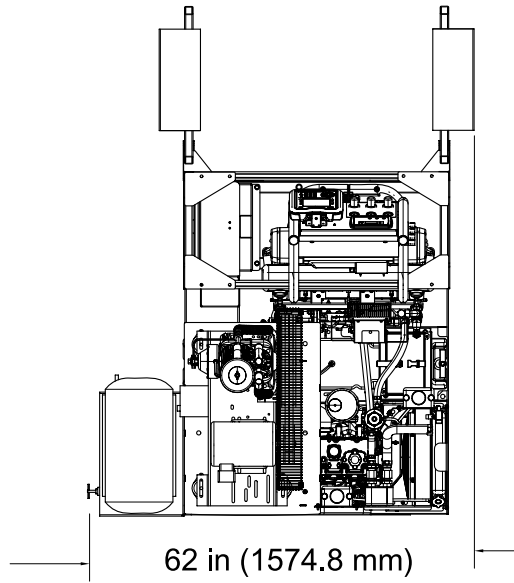

Top View: System with Compressor and Hose Rack Accessories
Figure 47

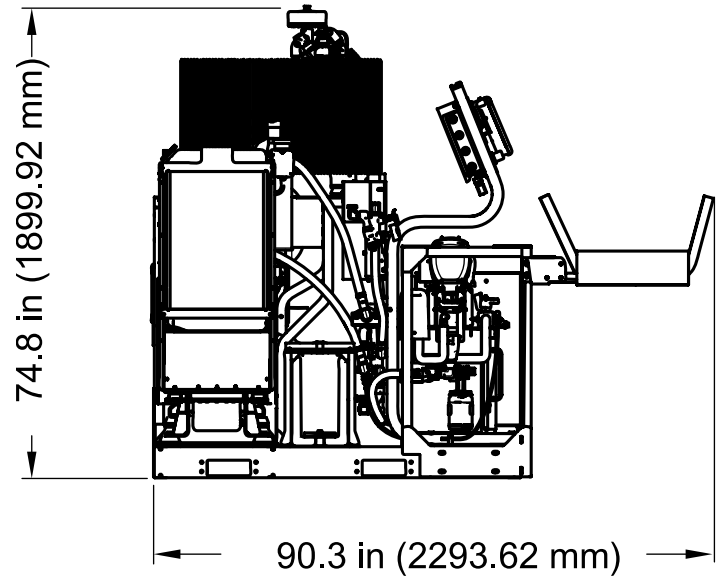

Side View: System with Compressor and Hose Rack Accessories
Figure 49

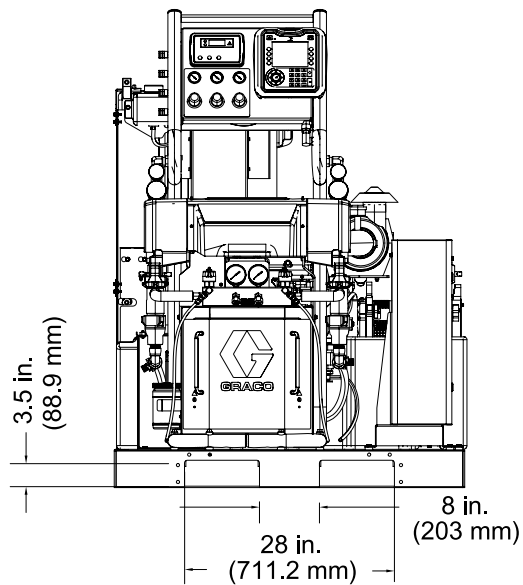

Front View
Figure 48

Dimensions

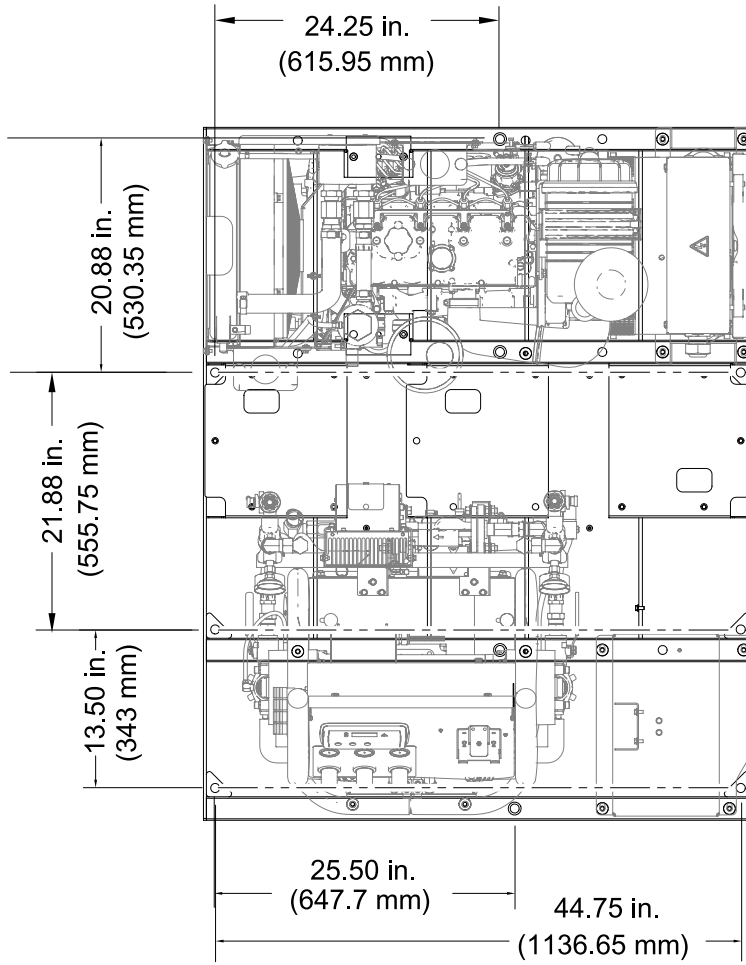

Pallet Mounting Dimensions
Figure 50

Performance Charts

Use these charts to help identify the proportioner that will work most efficiently with each mix chamber. Flow rates are based on a material viscosity of 60 cps.

Proportioners For Foam

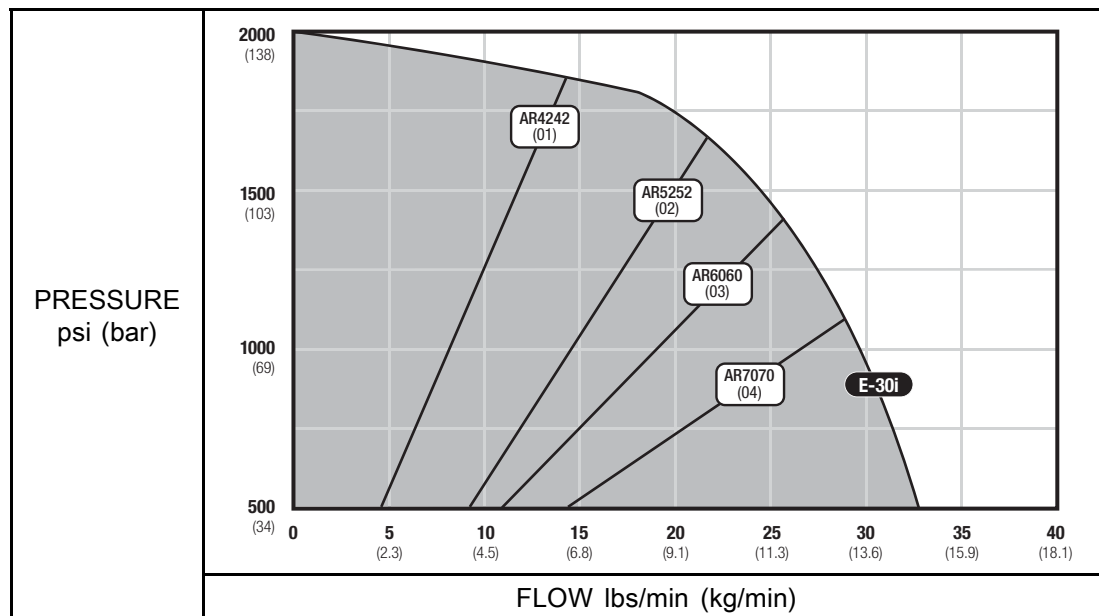

Proportioners For Coatings

Table 1 Fusion Air Purge, Round Pattern

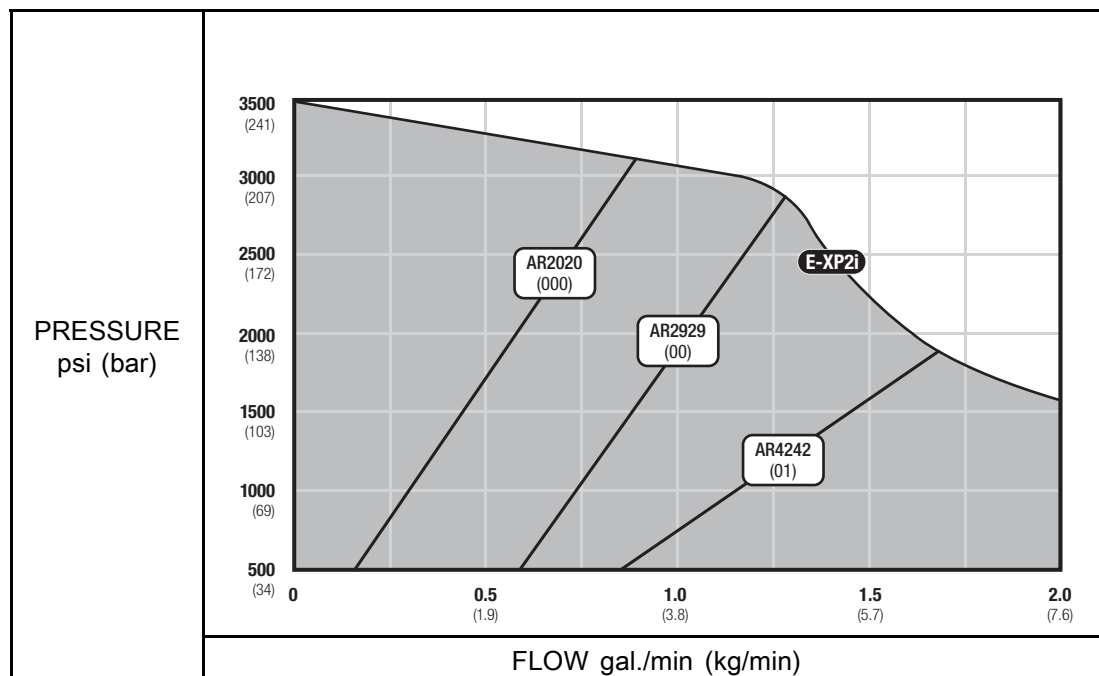

Table 2 Fusion Air Purge, Flat Pattern

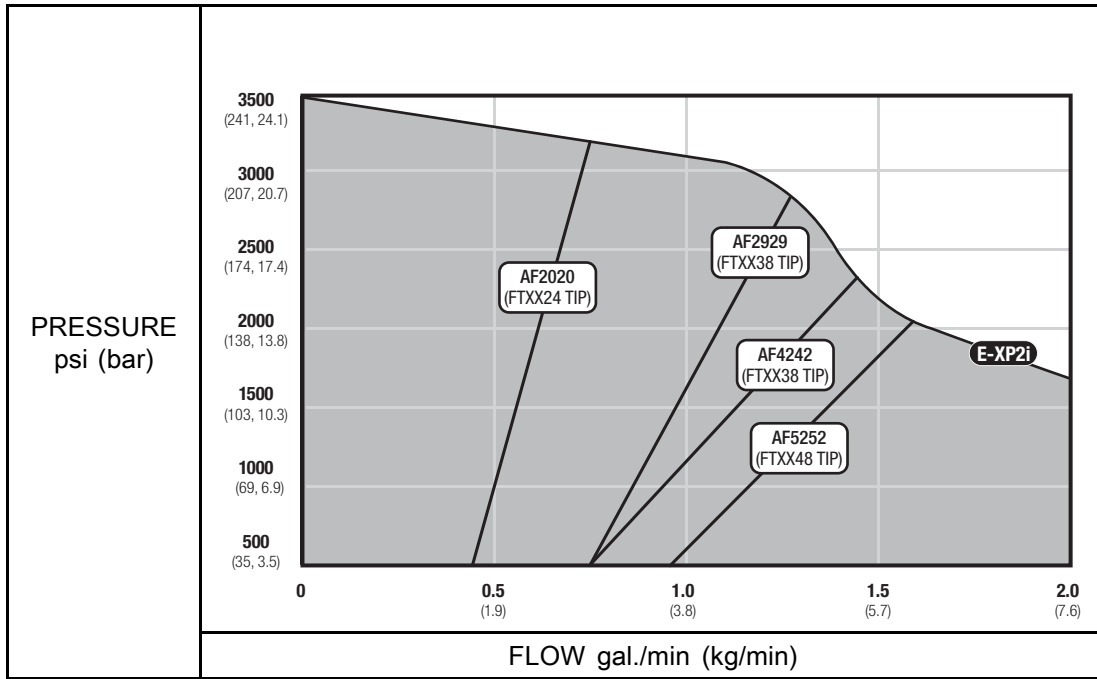

Table 3 Fusion Mechanical Purge, Round Pattern

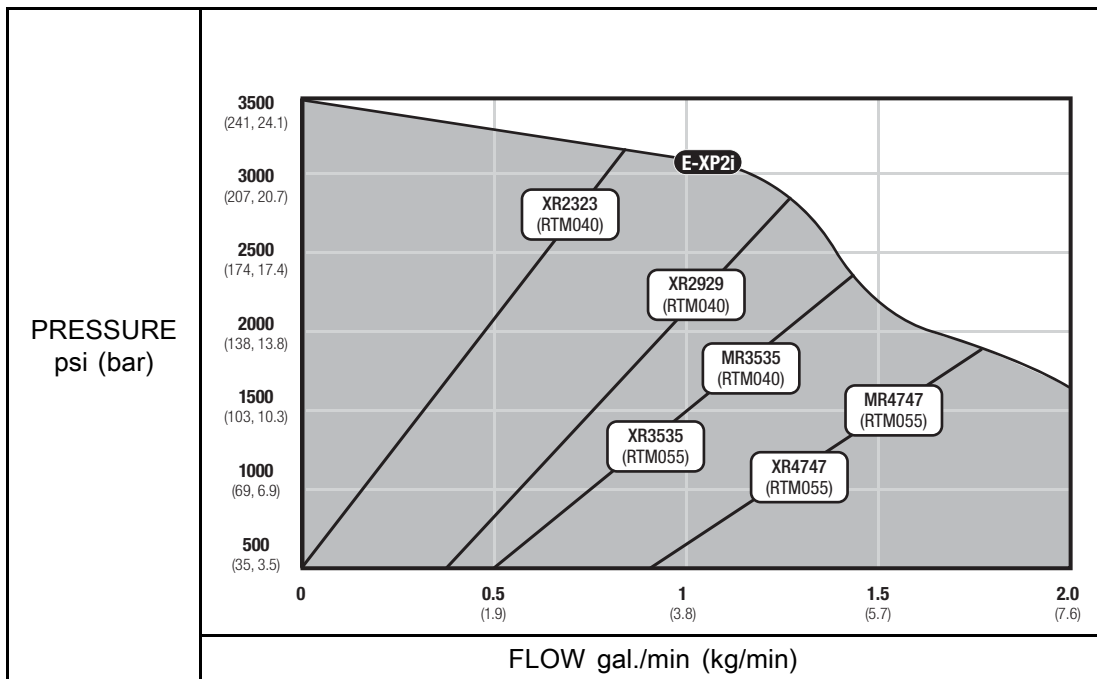
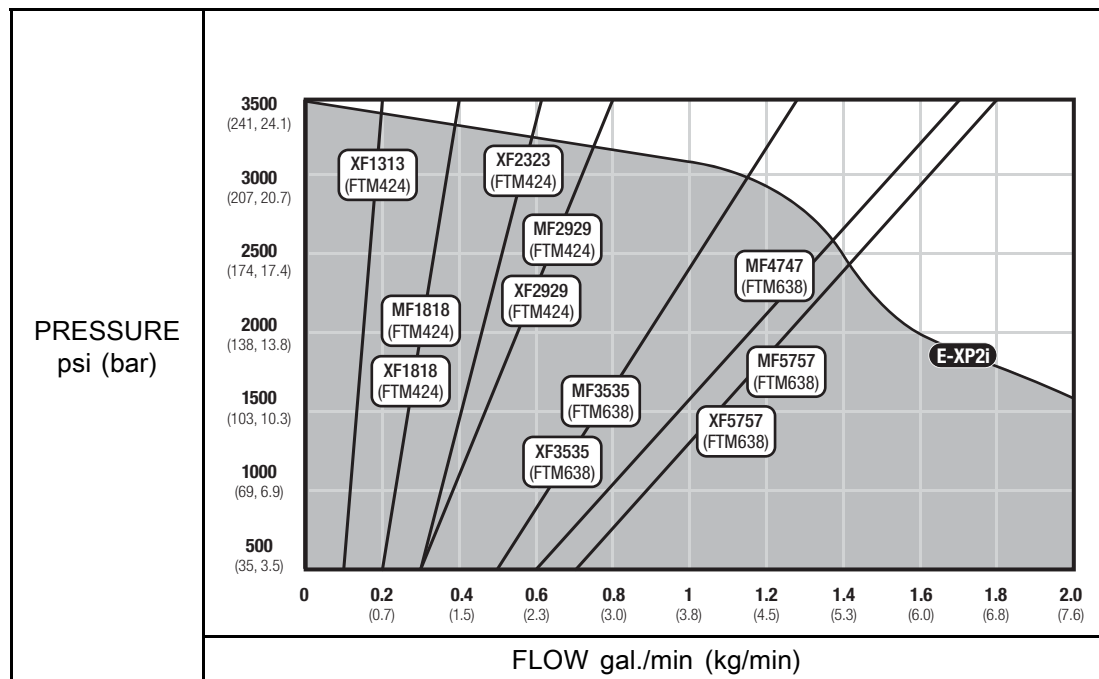

Table 4 Fusion Mechanical Purge, Flat Pattern



Technical Specifications

E-30i Models		
	U.S.	Metric
Maximum Fluid Working Pressure		
Pressure	2000 psi	14 MPa, 140 bar
Maximum Fluid Temperature		
E-30i	140°F	60°C
E-30i with booster heater	180°F	82°C
Maximum Output		
Output	30 lb/min	13.5 kg/min
Maximum Heated Hose Length		
Length	310 ft	94 m
Output per Cycle		
A and B	0.0272 gal.	0.1034 liter
Operating Ambient Temperature Range		
Temperature	20° to 120°F	-7° to 49°C
Auxiliary Power Available		
Voltage	120 Vac or 240 Vac, 60 Hz	
Engine		
Model	Perkins 404-22G, 2.2 L, 29 HP	
Alternator		
Model	Mecc Alte 22 kW, 240 V, 1 PH, 60 Hz, pancake style	
Battery Requirements		
Voltage	12 Vdc	
Minimum Cold Cranking Amps	800 CCA	
Connection Type	Post Style	
Recommended Battery Size		
BC Group Number	34	
Length	10.25 in.	260 mm
Width	6.81 in.	173 mm
Height	7.88 in.	200 mm
Booster Heater Power		
E-30i	None	
E-30i with booster heat	4000 Watts	

Recommended Air Compressors		
Champion® BR-5, Base Mount		
Specifications	5 HP, 240 V, 1 Phase, 60 Hz, 21 cfm	
Required Features	Belt guard aftercooler	
	Pilot valve unloader	
Quincy QP-5-5B, Base Mount		
Specifications	5 HP, 240 V, 1 Phase, 60 Hz, 17.2 cfm	
Required Features	Belt guard aftercooler	
	Pilot valve unloader	
Champion® HR5-3, 30 Gallon Tank Mount		
Specifications	5 HP, 240 V, 1 Phase, 60 Hz, 21 cfm	
Required Features	Pilot valve unloader	
Noise		
Sound Pressure measured from 3.1 ft (1 m), at 1500 psi (10 MPa, 103 bar), 2 gpm (7.6 lpm)	91.0 dBA	
Fluid Inlets		
Component A (ISO) and Component B (RES)	3/4 NPT(f) with 3/4 NPSM(f) union	
Fluid Outlets		
Component A (ISO)	#8 (1/2 in.) JIC, with #5 (5/16 in.) JIC adapter	
Component B (RES)	#10 (5/8 in.) JIC, with #6 (3/8 in.) JIC adapter	
Fluid Circulation Ports		
Size	1/4 NPSM(m), with plastic tubing	
Maximum Pressure	250 psi	1.75 MPa, 17.5 bar
Weight		
E-30i	1750 lb	794 kg
E-30i with booster heat	1800 lb	816 kg
E-30i with compressor	2250 lb	1020 kg
E-30i with booster heat and compressor	2300 lb	1043 kg
Wetted Parts		
Material	Aluminum, stainless steel, zinc plated carbon steel, brass, carbide, chrome, chemically resistant o-rings, PTFE, ultra-high molecular weight polyethylene	

E-XP2i Models		
	U.S.	Metric
Maximum Fluid Working Pressure		
Pressure	3500 psi	24.1 MPa, 241 bar
Maximum Fluid Temperature		
E-XP2i	180°F	82°C
Maximum Output		
Output	2 gpm	7.6 lpm
Maximum Heated Hose Length		
Length	310 ft	94 m
Output per Cycle		
A and B	0.0203 gal.	0.0771 liter
Operating Ambient Temperature Range		
Temperature	20° to 120°F	-7° to 49°C
Auxiliary Power Available		
Voltage	120 Vac or 240 Vac, 60 Hz	
Engine		
Model	Perkins 404-22G, 2.2 L, 29 HP	
Alternator		
Model	Mecc Alte 22 kW, 240 V, 1 PH, 60 Hz, pancake style	
Battery Requirements		
Voltage	12 Vdc	
Minimum Cold Cranking Amps	800 CCA	
Connection Type	Post Style	
Recommended Battery Size		
BC Group Number	34	
Length	10.25 in.	260 mm
Width	6.81 in.	173 mm
Height	7.88 in.	200 mm
Booster Heater Power		
Wattage	4000 Watts	

Recommended Air Compressors		
Champion® BR-5, Base Mount		
Specifications	5 HP, 240 V, 1 Phase, 60 Hz, 21 cfm	
Required Features	Belt guard aftercooler	
	Pilot valve unloader	
Quincy QP-5-5B, Base Mount		
Specifications	5 HP, 240 V, 1 Phase, 60 Hz, 17.2 cfm	
Required Features	Belt guard aftercooler	
	Pilot valve unloader	
Champion® HR5-3, 30 Gallon Tank Mount		
Specifications	5 HP, 240 V, 1 Phase, 60 Hz, 21 cfm	
Required Features	Pilot valve unloader	
Noise		
Sound Pressure measured from 3.1 ft (1 m), at 2000 psi (14 MPa, 138 bar), 1.0 gpm (3.8 lpm)	91.0 dBA	
Fluid Inlets		
Component A (ISO) and Component B (RES)	3/4 NPT(f) with 3/4 NPSM(f) union	
Fluid Outlets		
Component A (ISO)	#8 (1/2 in.) JIC, with #5 (5/16 in.) JIC adapter	
Component B (RES)	#10 (5/8 in.) JIC, with #6 (3/8 in.) JIC adapter	
Fluid Circulation Ports		
Size	1/4 NPSM(m), with plastic tubing	
Maximum Pressure	250 psi	1.75 MPa, 17.5 bar
Weight		
E-XP2i	1800 lb	816 kg
E-XP2i with compressor	2500 lb	1043 kg
Wetted Parts		
Material	Aluminum, stainless steel, zinc plated carbon steel, brass, carbide, chrome, chemically resistant o-rings, PTFE, ultra-high molecular weight polyethylene	

Graco Standard Warranty

Graco warrants all equipment referenced in this document which is manufactured by Graco and bearing its name to be free from defects in material and workmanship on the date of sale to the original purchaser for use. With the exception of any special, extended, or limited warranty published by Graco, Graco will, for a period of twelve months from the date of sale, repair or replace any part of the equipment determined by Graco to be defective. This warranty applies only when the equipment is installed, operated and maintained in accordance with Graco's written recommendations.

This warranty does not cover, and Graco shall not be liable for general wear and tear, or any malfunction, damage or wear caused by faulty installation, misapplication, abrasion, corrosion, inadequate or improper maintenance, negligence, accident, tampering, or substitution of non-Graco component parts. Nor shall Graco be liable for malfunction, damage or wear caused by the incompatibility of Graco equipment with structures, accessories, equipment or materials not supplied by Graco, or the improper design, manufacture, installation, operation or maintenance of structures, accessories, equipment or materials not supplied by Graco.

This warranty is conditioned upon the prepaid return of the equipment claimed to be defective to an authorized Graco distributor for verification of the claimed defect. If the claimed defect is verified, Graco will repair or replace free of charge any defective parts. The equipment will be returned to the original purchaser transportation prepaid. If inspection of the equipment does not disclose any defect in material or workmanship, repairs will be made at a reasonable charge, which charges may include the costs of parts, labor, and transportation.

THIS WARRANTY IS EXCLUSIVE, AND IS IN LIEU OF ANY OTHER WARRANTIES, EXPRESS OR IMPLIED, INCLUDING BUT NOT LIMITED TO WARRANTY OF MERCHANTABILITY OR WARRANTY OF FITNESS FOR A PARTICULAR PURPOSE.

Graco's sole obligation and buyer's sole remedy for any breach of warranty shall be as set forth above. The buyer agrees that no other remedy (including, but not limited to, incidental or consequential damages for lost profits, lost sales, injury to person or property, or any other incidental or consequential loss) shall be available. Any action for breach of warranty must be brought within two (2) years of the date of sale.

GRACO MAKES NO WARRANTY, AND DISCLAIMS ALL IMPLIED WARRANTIES OF MERCHANTABILITY AND FITNESS FOR A PARTICULAR PURPOSE, IN CONNECTION WITH ACCESSORIES, EQUIPMENT, MATERIALS OR COMPONENTS SOLD BUT NOT MANUFACTURED BY GRACO. These items sold, but not manufactured by Graco (such as electric motors, switches, hose, etc.), are subject to the warranty, if any, of their manufacturer. Graco will provide purchaser with reasonable assistance in making any claim for breach of these warranties.

In no event will Graco be liable for indirect, incidental, special or consequential damages resulting from Graco supplying equipment hereunder, or the furnishing, performance, or use of any products or other goods sold hereto, whether due to a breach of contract, breach of warranty, the negligence of Graco, or otherwise.

FOR GRACO CANADA CUSTOMERS

The Parties acknowledge that they have required that the present document, as well as all documents, notices and legal proceedings entered into, given or instituted pursuant hereto or relating directly or indirectly hereto, be drawn up in English. Les parties reconnaissent avoir convenu que la rédaction du présente document sera en Anglais, ainsi que tous documents, avis et procédures judiciaires exécutés, donnés ou intentés, à la suite de ou en rapport, directement ou indirectement, avec les procédures concernées.

Graco Information

For the latest information about Graco products, visit www.graco.com.

To place an order, contact your Graco Distributor or call to identify the nearest distributor.

Phone: 612-623-6921 **or Toll Free:** 1-800-328-0211 **Fax:** 612-378-3505

All written and visual data contained in this document reflects the latest product information available at the time of publication.

Graco reserves the right to make changes at any time without notice.

For patent information, see www.graco.com/patents.

Original Instructions. This manual contains English. MM 3A1705

Graco Headquarters: Minneapolis

International Offices: Belgium, China, Japan, Korea

GRACO INC. AND SUBSIDIARIES • P.O. BOX 1441 • MINNEAPOLIS MN 55440-1441 • USA

Copyright 2011, Graco Inc. All Graco manufacturing locations are registered to ISO 9001.

www.graco.com

Revised September 2013