

ROTOLOK

everything under control...

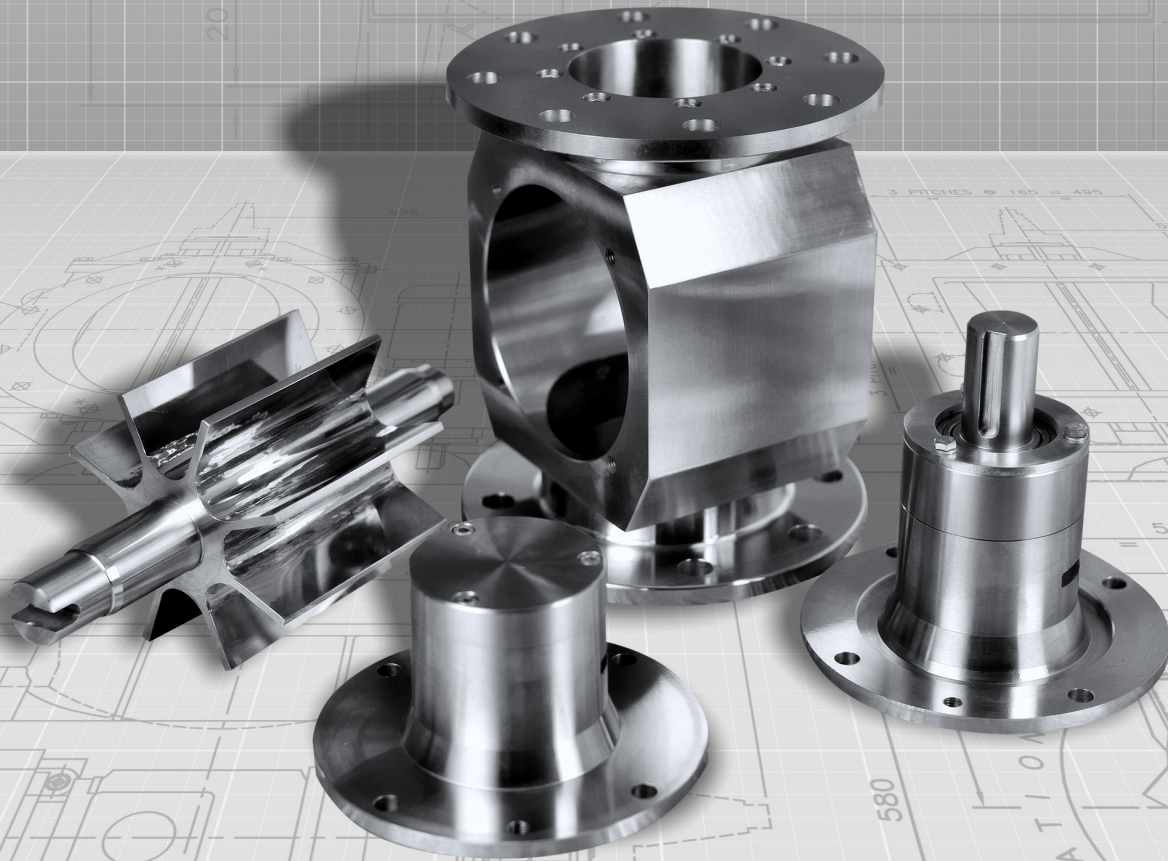

ROTOLOK USA

Industrial Ventures II
2711 Gray Fox Road
Monroe
North Carolina
28110
United States of America
Tel: +1 (704) 282 4444
Fax: +1 (704) 282 4242
www.rotolok.us
sales@rotolok.us



HYGIENIC ROTARY KLEANLOK



INTRODUCTION

The prime function of Rotary Airlocks is to regulate the flow of dust, powder and granular products from one chamber to another whilst maintaining a good airlock.

It is popularly used in pneumatic conveying systems, both vacuum and pressure, together with cyclone and filter applications.

However, the Kleanlok is a more specialist valve. Its modular design makes it an easy-clean valve, aimed specifically at the food, chemical and pharmaceutical industries, where cleanliness, both internally and externally, must be to a high standard.

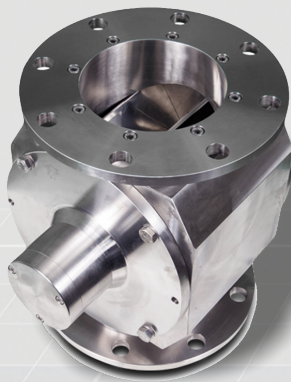

KLEANLOK

Rotolok manufactures a complete range of Rotary Airlocks and in the past, for hygienic applications, the standard range has been used, resulting in large costs being incurred to meet the food standards with regards to polishing etc.

The Kleanlok is, by design, a different concept as it has been styled to ensure that all internal and external surfaces can be fully machined, creating a smooth surface with no lodgement points. This minimises and simplifies polishing and enables the user to clean or wash the valve quickly and easily.

The drive is normally direct coupled, making the complete assembly more compact and eliminating the need for motor mounting plates and bosses, which significantly complicate the external cleaning operation.

The Kleanlok has a compact and modular design to reduce the time spent on disassembly when cleaning.

All valves of this model have the quick release rotor feature as standard.

RANGE

All Kleanloks are constructed from cast stainless steel with stainless steel rotors, to meet hygiene requirements. Standard range sizes, 3'' to 10'' diameter, but this will be extended to suit customer needs.

KLEANLOK DIAGRAM

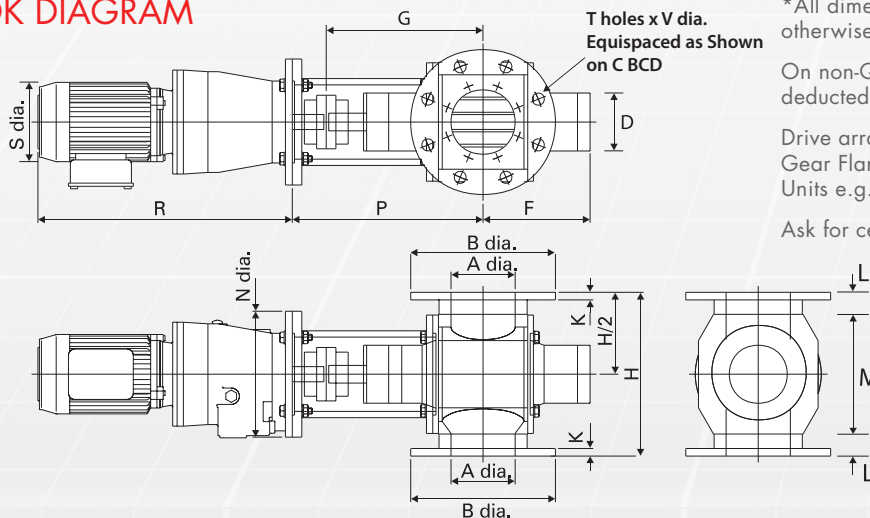

*All dimensions are in inches unless stated otherwise.

On non-Quick Release Models, 1 1/2'' should be deducted from 'G' and 'P' dimensions.

Drive arrangement is for our Standard Helical Gear Flange Mounted Unit. Other Mounting Units e.g. Worm Boxes can be accommodated.

Ask for certified drawing.

SIZE	A	B	C	D	F	G	H	K	L	M	N	P	R	S	T	V	CU FT/REV	HP
3"	3"	7 1/2"	6"	3 3/8"	6"	9"	8 1/4"	1/2"	1 3/8"	5 1/2"	7 7/8"	11 1/16"	16 1/2"	4 1/16"	4	3/4"	.02	1/2
4"	4"	9"	7 1/2"	3 3/8"	6 3/4"	9 7/8"	10 1/4"	1/2"	1 3/8"	7 1/2"	7 7/8"	12"	16 1/2"	4 1/16"	8	3/4"	.08	1/2
6"	6"	11"	9 1/2"	3 3/8"	7 7/8"	10 7/8"	12 3/8"	1/2"	1 3/8"	10 1/8"	7 7/8"	13 1/8"	16 1/2"	5"	8	7/8"	.23	1/2
8"	8"	13 1/2"	11 3/4"	3 3/8"	8 3/4"	12 1/8"	15 1/8"	1/2"	1 3/8"	12 13/16"	11 7/8"	15"	18 1/8"	6 1/4"	8	7/8"	.50	1
10"	10"	16"	14 1/4"	3 3/8"	9 7/8"	13 3/8"	20 1/2"	3/4"	2"	16 1/2"	11 7/8"	16 1/8"	17 3/4"	6 1/4"	12	1"	1.00	1

Dimensions are approximate and subject to change without notice

Planning-in detail for general guidance only

(To cover safety aspects ask for our safety leaflets)

Drillings are Rotolok standards. Variations can be made.



KLEANLOK - EASY RELEASE

The Kleanlok is a staple of the Rotolok product range and the Easy Release model is a natural extension of it. The Easy Release rail system has already proven itself on our standard Rotary Valves as an effective and simple solution that eases cleaning and maintenance. The Easy Release function is simple and easy to use, so much so that it can be done by a single person reducing the amount of man power required to perform cleaning.

Once the end cover has been unscrewed from the body it simply slides out on the rails with the Rotor attached. From here it is easy to clean the rotor, rotating it as needed to ensure that all blades and pockets are thoroughly cleaned.

The internals of the body can also be accessed while the rotor has been removed. Then when the internals have been cleaned, all that is left to do is slide the rotor back in and screw the end cover back to the body then normal operation can resume.

Due to the addition of rails on the Easy Release model, more room is required to install the valve, but this is a small price to pay for the increased ease of cleaning and maintenance which will save on both time and cost involved with each.

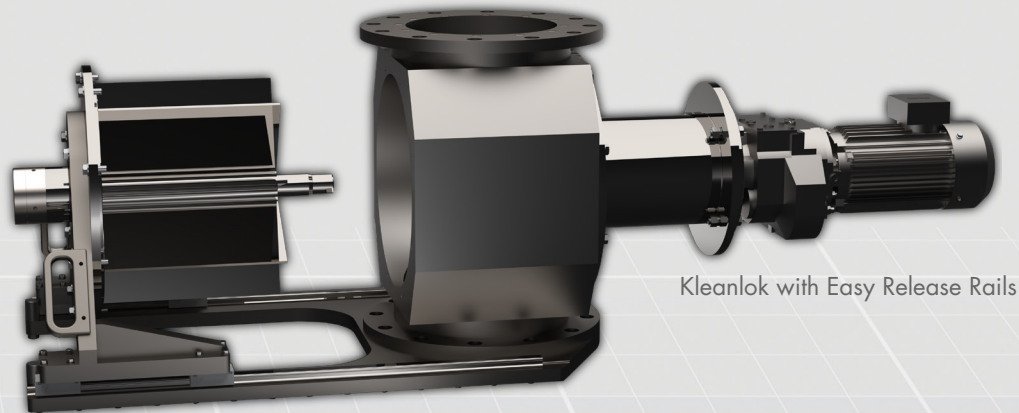

Kleanlok with Easy Release Rails

KLEANLOK - OTHER VARIATIONS

Our Kleanloks are, like our standard Rotary Valve, very adaptable. In the past we have made many special versions to suit different applications and to handle various difficult products. Some of these adaptations include:

- Special Rotor designs, including reduced capacity
- Reduced Rotor speed
- Dropout boxes/Blowing Seal addition
- Specialised components
- Non-standard assembly methods

With all these options and many more, Rotolok can provide a piece of equipment to handle virtually any product.

An example of a Kleanlok with a Blowing Seal addition for conveying applications.

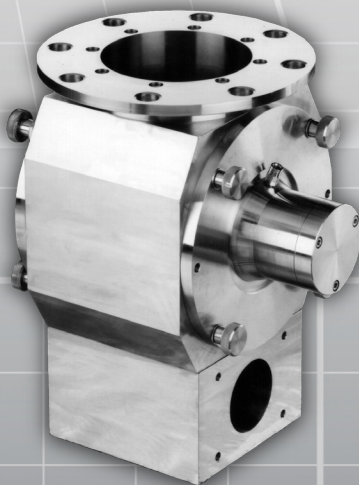

An example of a specialised Rotor. Stainless Steel with staggered pockets.

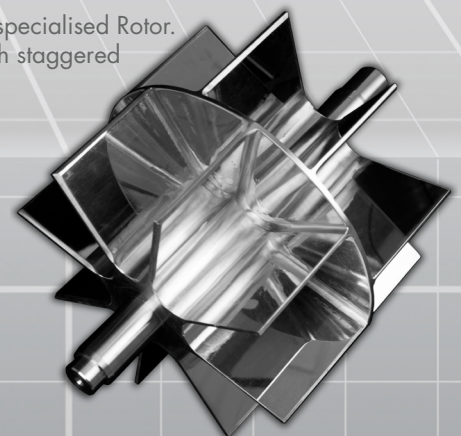

OTHER ROTOLOK PRODUCTS

As well as the Kleanlok, Rotolok manufacture and supply a range of other products in Stainless Steel for use in systems where cleanliness is key.

These include, but are not limited to: Slide Gates with Pneumatic, Motorised or Manual operation; Rotary Valves; Dust Collector Valves; Roundhead Valves; Blowing Seals and various Diverter Valves.

For more information, please visit our website or contact our sales team.

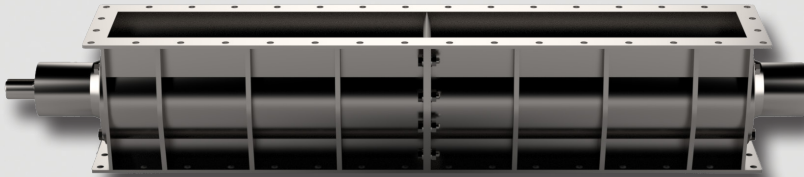

An example of a bespoke Rotary Valve. This valve has an elongated body, a special rotor design and custom operating speed.

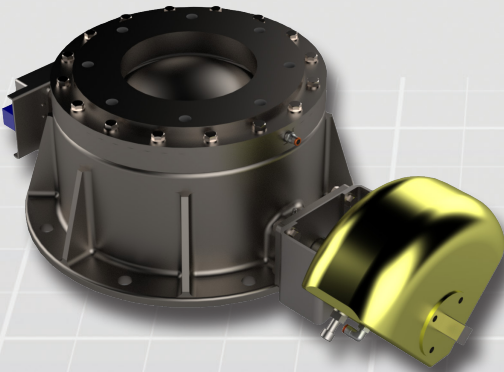

Suited for pressure applications, the roundhead valve is available in Stainless Steel as well as Cast Iron

A Stainless Steel Rotary Valve with Easy Release system for heavier duty applications.

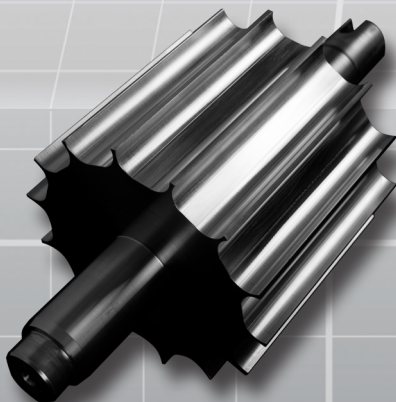
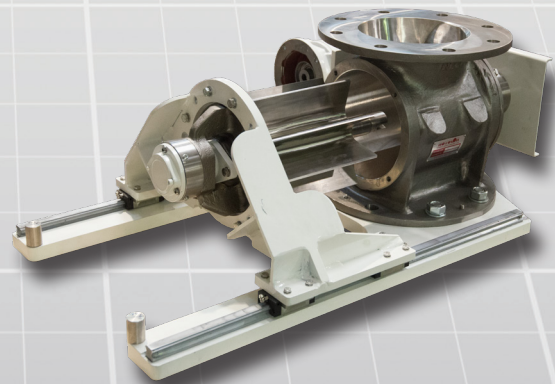

A special Stainless Steel Rotor. The Rotor has fourteen pockets, each of reduced capacity for rapid, consistent feeding.

