

# Project Slide Glass Sliding Doors

Borrow light from any room with this easy to install frameless sliding glass door system



## Features

- High tech complete solution for frameless sliding glass door systems.
- Smooth running and ease of movement.
- Mounting is quick, intuitive and thus cost-effective.
- Soft closing mechanism
- All-metal dampers with high quality hydraulics and a double sided spring guide.
- No floor channel required on doors up to 1500mm
- Available with new edge lit LED glass design

## Applications

- Bathroom and En-suite glass doors
- Lounge and Dining Rooms
- Bedrooms
- Hotels, Restaurants and Bars
- Offices, can be branded with company logos.
- Available in Clear, Obscure or etched with over 28 unique designs.

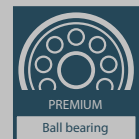
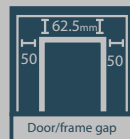
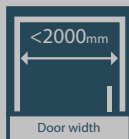

# Technical Specification

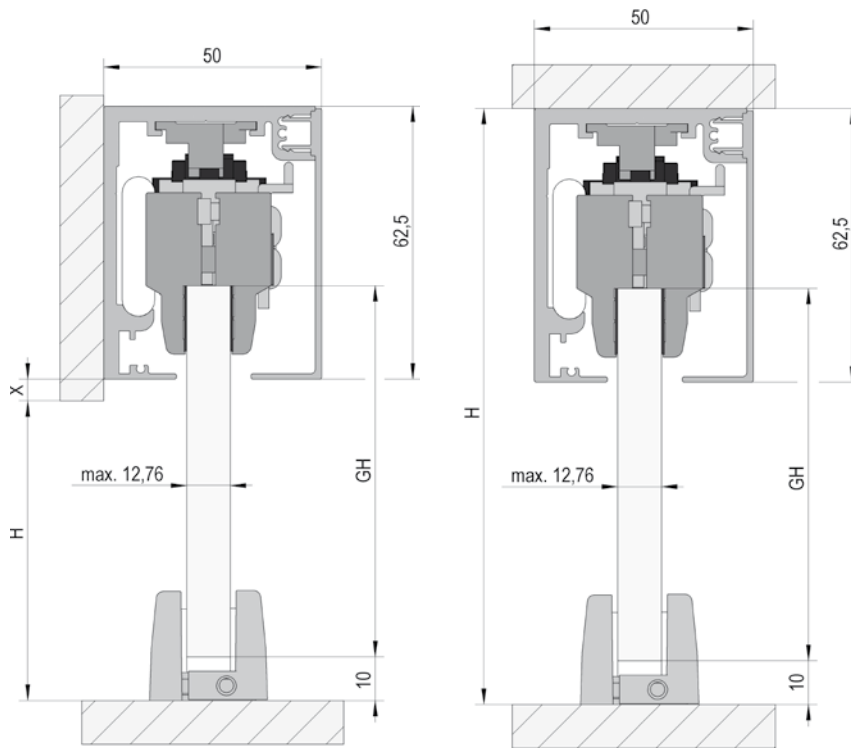

## Breakdown

**1** Each Project Slide glass door is individually cut to size. Available either wall or ceiling mounted all tolerances are made to the opening size ensuring a perfect fit every time.

Easy to follow installation instructions are included, each door will arrive with the rollers pre-fitted and tracks cut to size complete with handles and end caps.

**2** Glass is 10mm - 12mm UK Toughened glass meeting all BS and EN standards. Each door is carefully cut and toughened to size using only the highest quality European manufactured glass. Edges are in-line flat polished allowing for an uninterrupted frameless view.

**3** Glass options include Clear, Low Iron, Obscure, Sandblasted etched, or why not include a project design and add a bespoke element to your glass door. Choose from a range of 28 contemporary designs bringing subjects such as geometric, nature, the human form and transport.

Perfect for any commercial application including hotels, bars, restaurants and offices - company logos can be added to the glass doors giving numerous branding options.

**4** System is available for doors from 790mm to 2000mm width, please contact us for doors outside of these sizes. Also available for double glass doors and doors with fixed side panels.

[goglass.co.uk](http://goglass.co.uk)

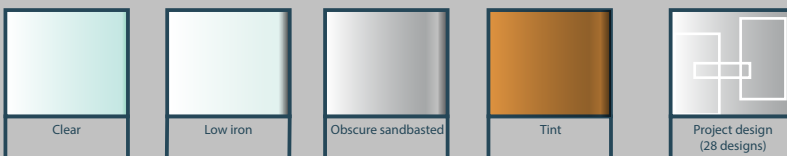

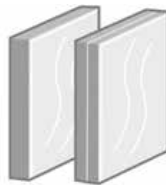
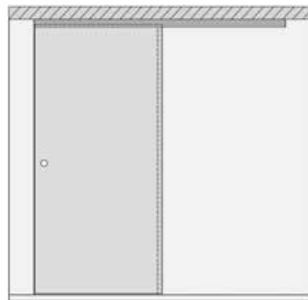
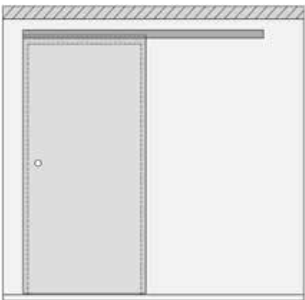

60 kg

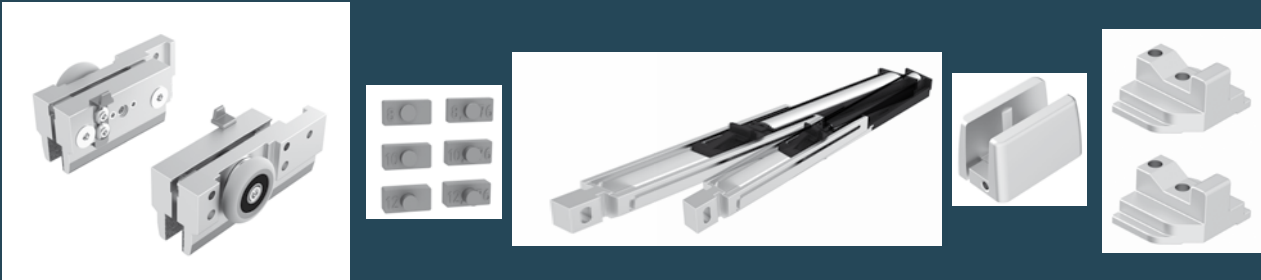

80 kg



120 / 150 kg

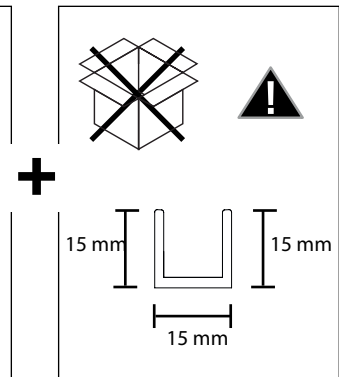
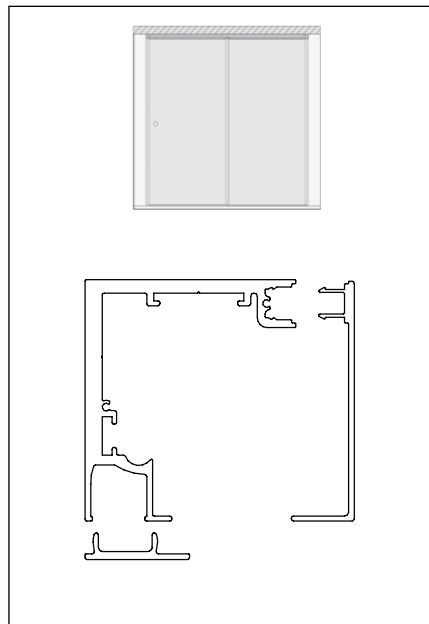
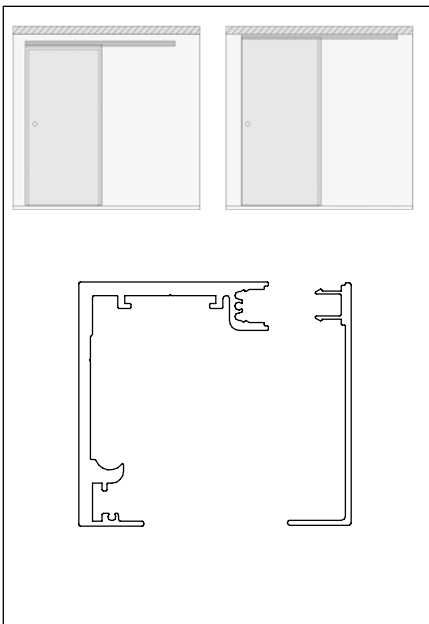

U-Channel

EV1: BO 5201564  
C31: BO 5201565

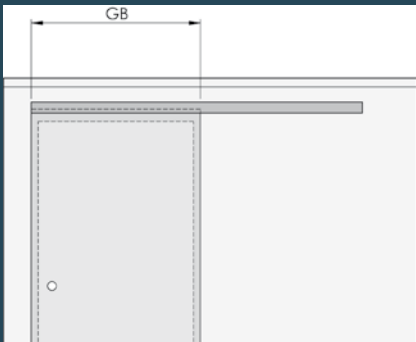

	60 kg	80 kg	120 kg	150 kg
GB (mm)	min 600	min 790	min 905	min 905

$$GH = H + X + 11,5$$

$$GH = H - 51$$

$$GH = H - 51$$

$$GHS = H - 61$$

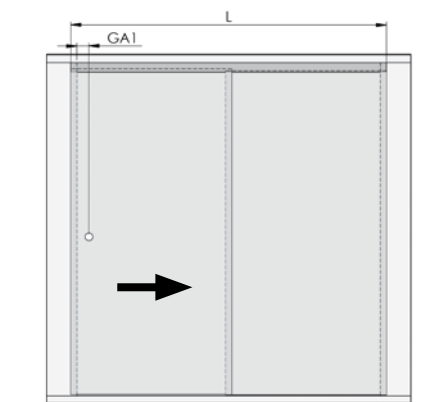
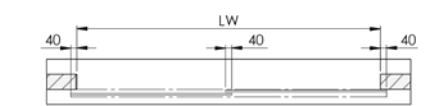
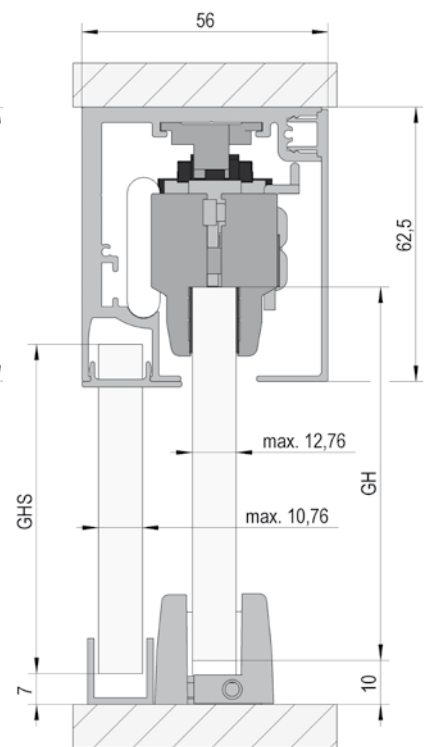
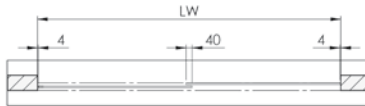
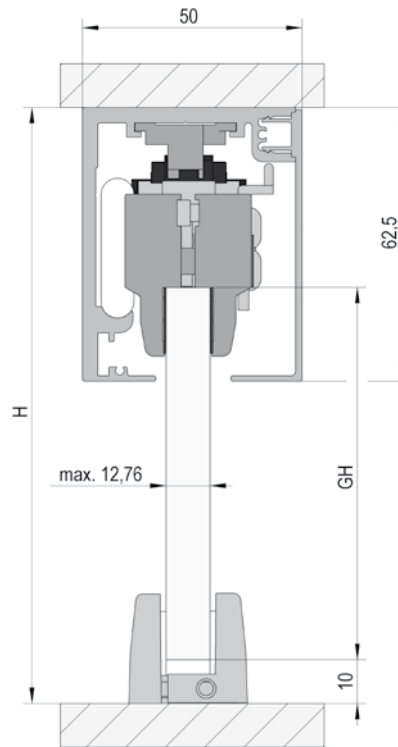
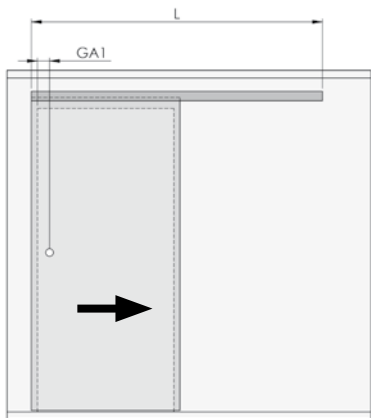
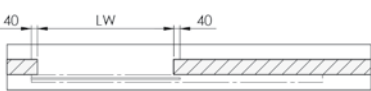
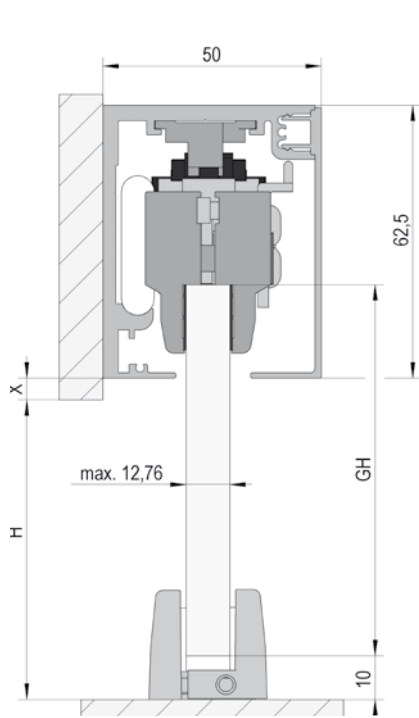

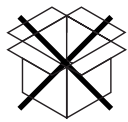

4

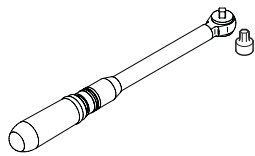

2

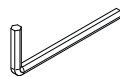

2,5

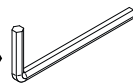

3

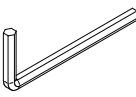

4

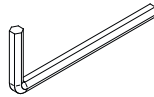

01

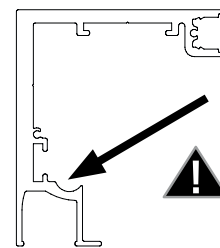
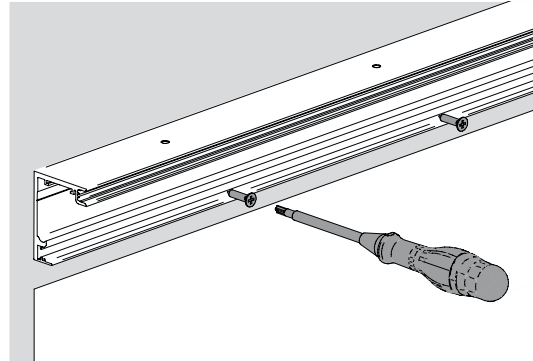
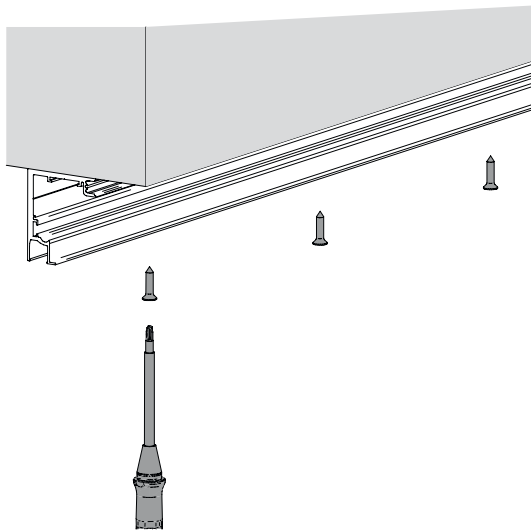

02

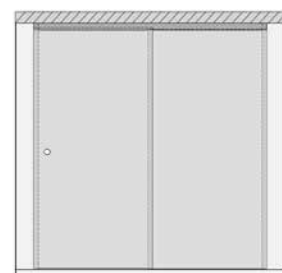
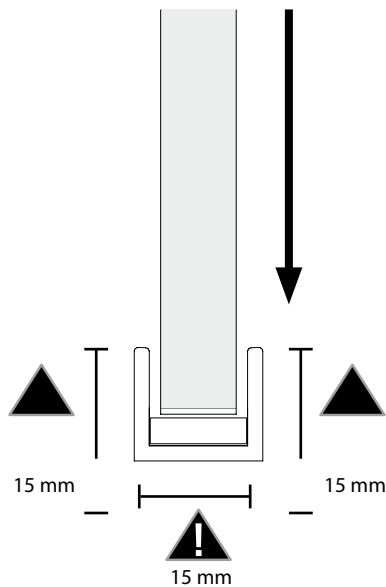
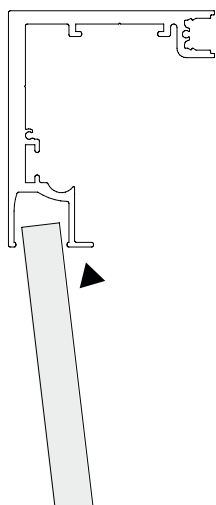

03

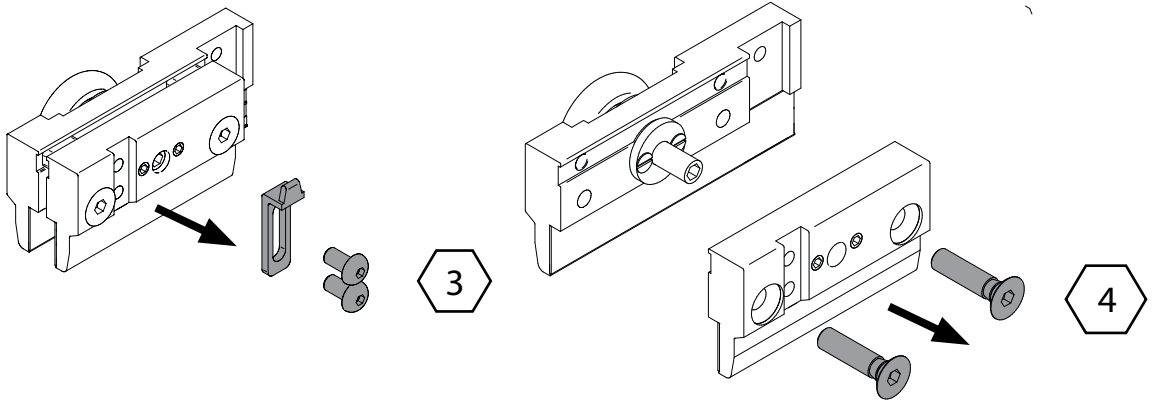

04

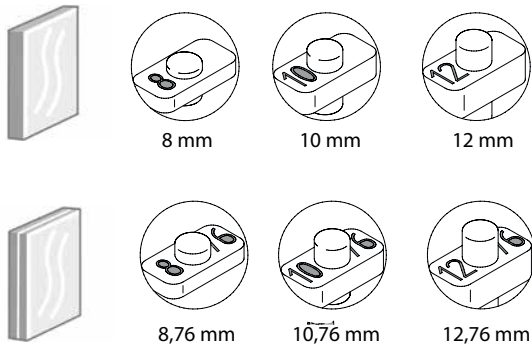

60 kg

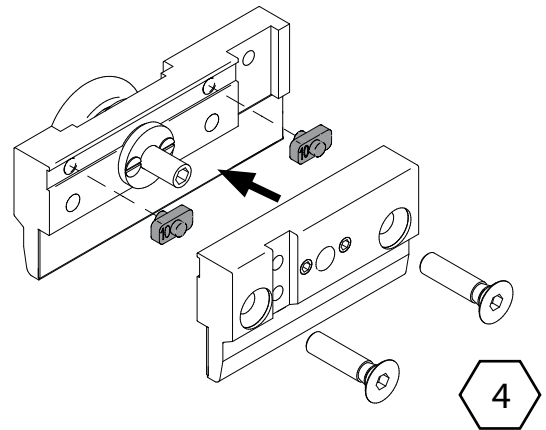

80 kg

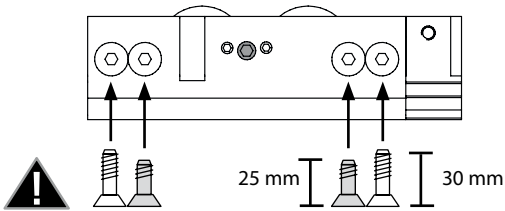

120 / 150 kg

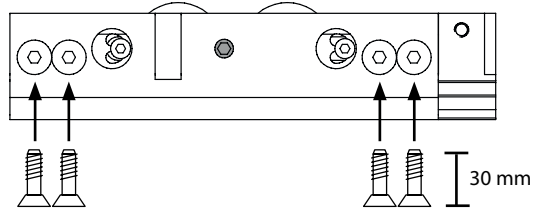

05

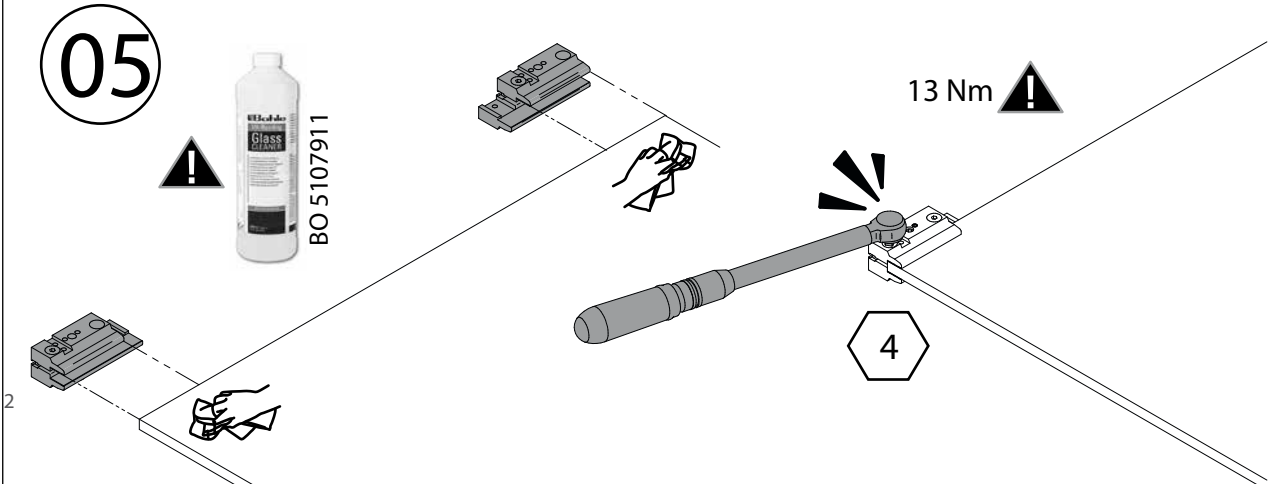



06

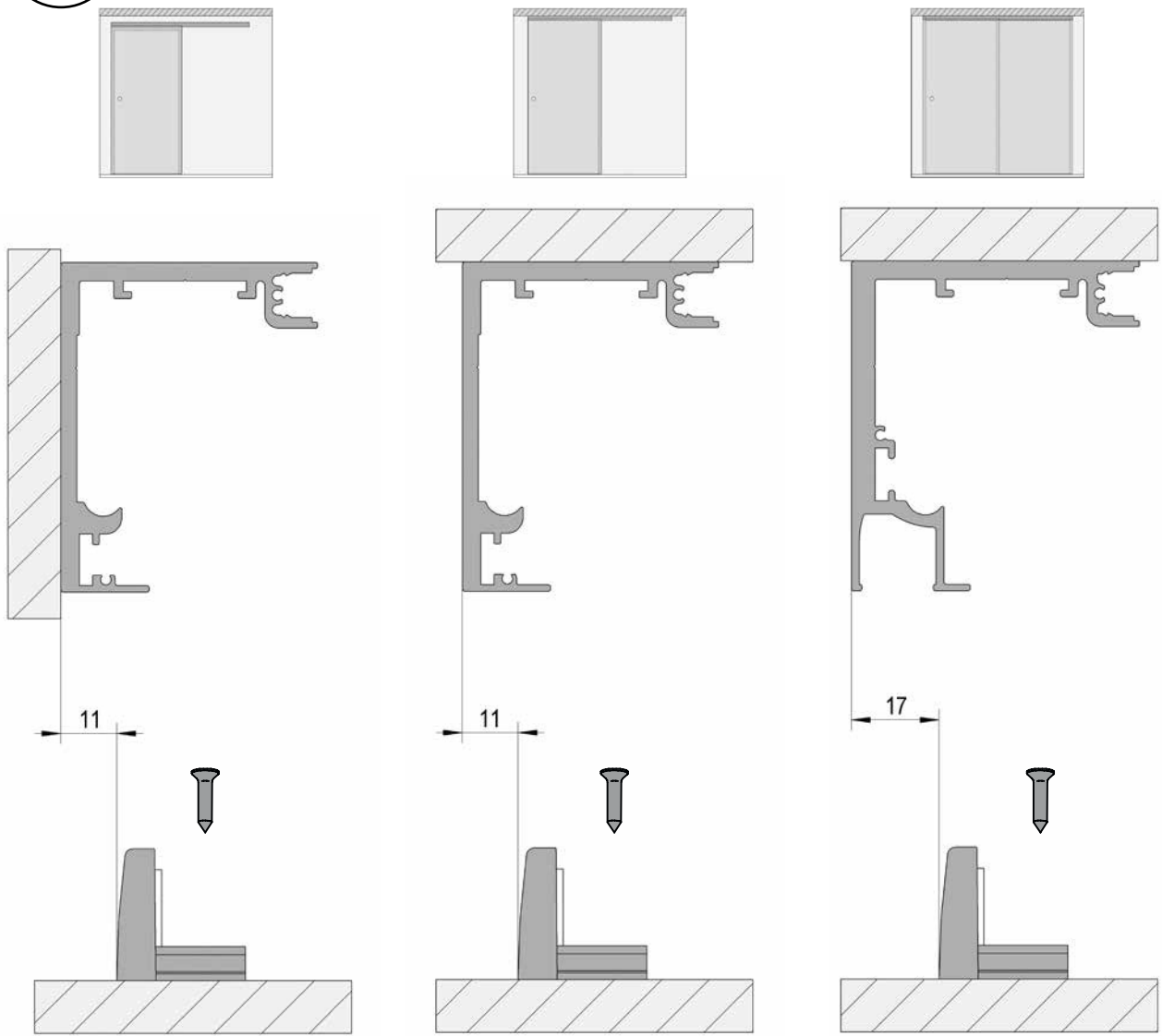

07

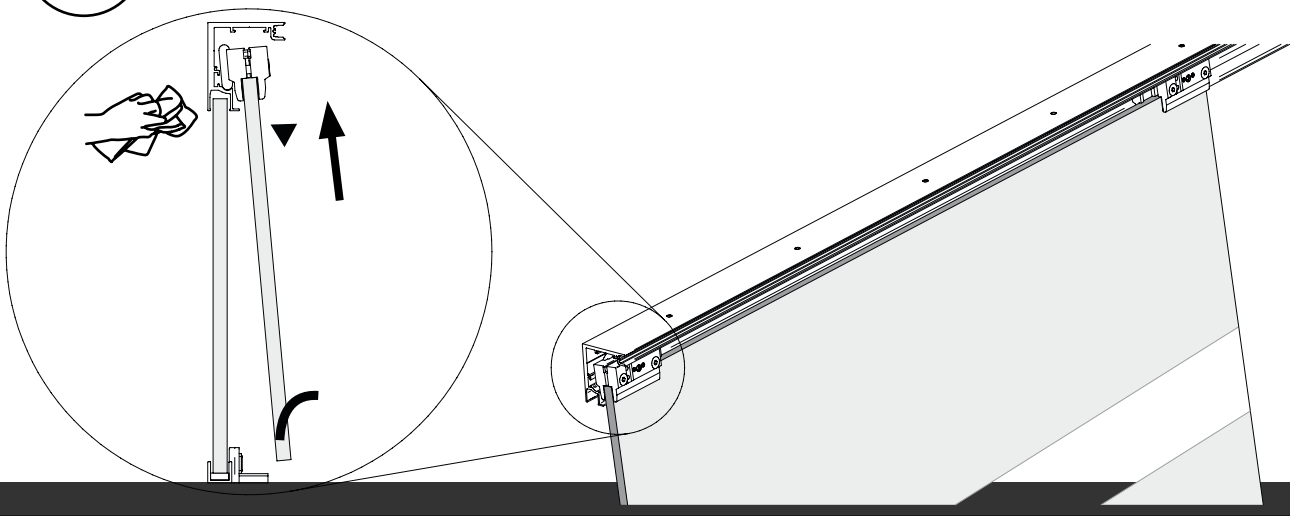



60 kg

08

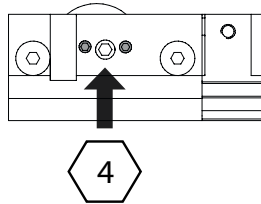
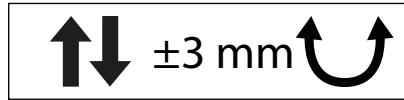
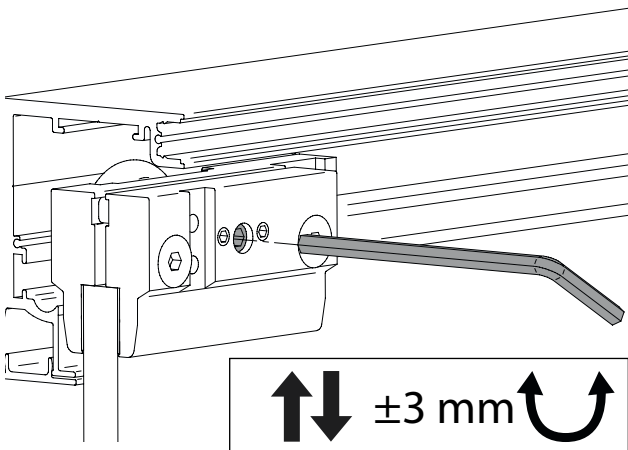

09

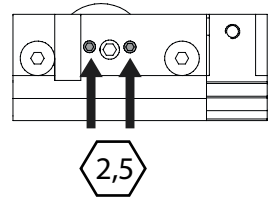
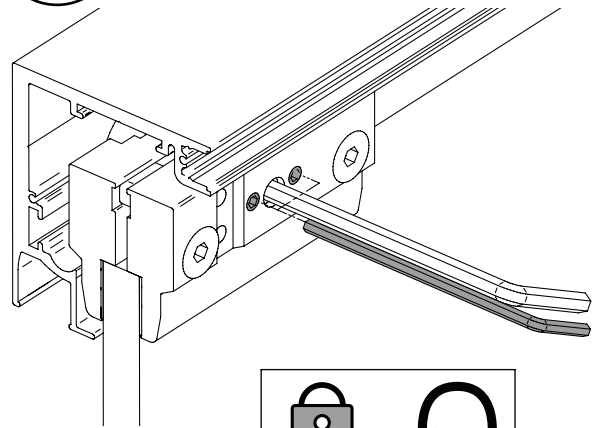

80 kg

08

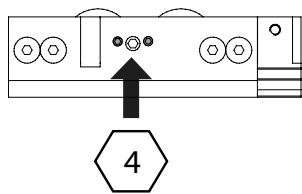
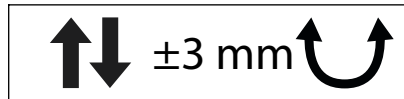
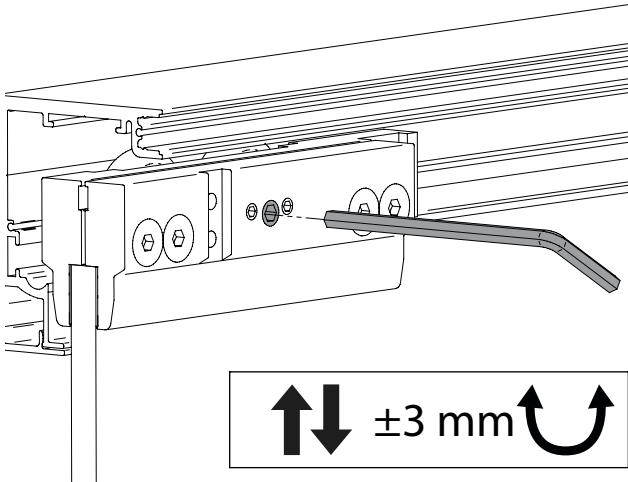

09

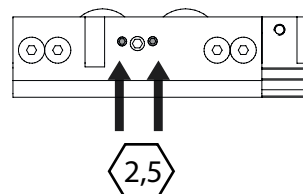
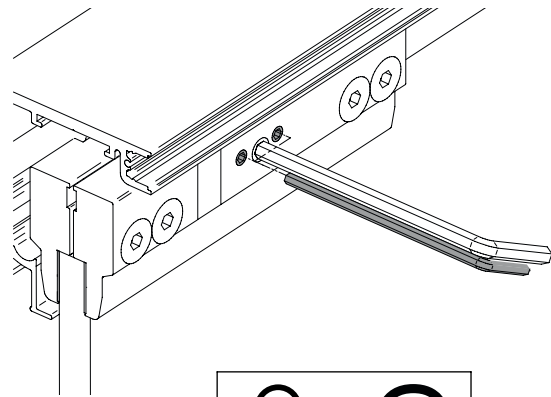

08

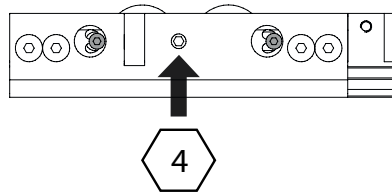
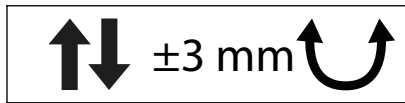
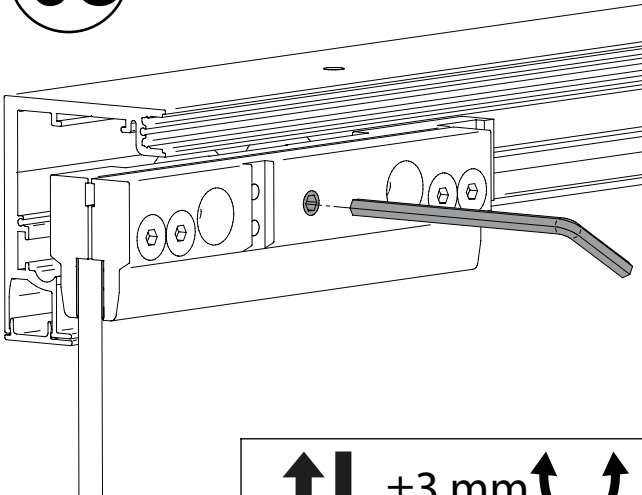

09

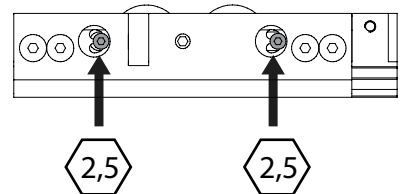
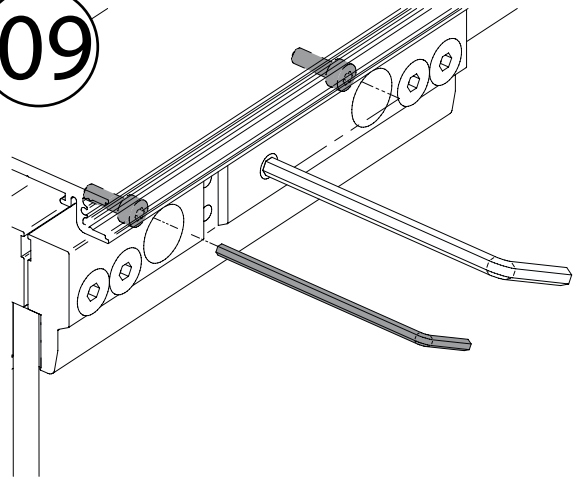

10

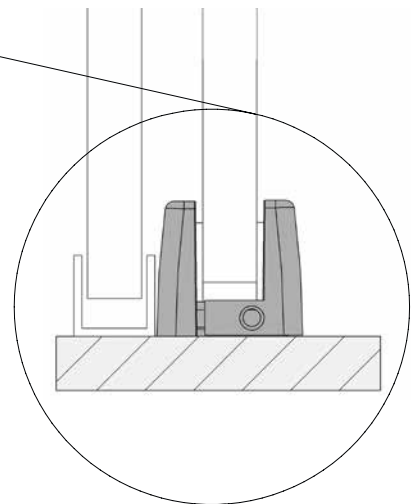
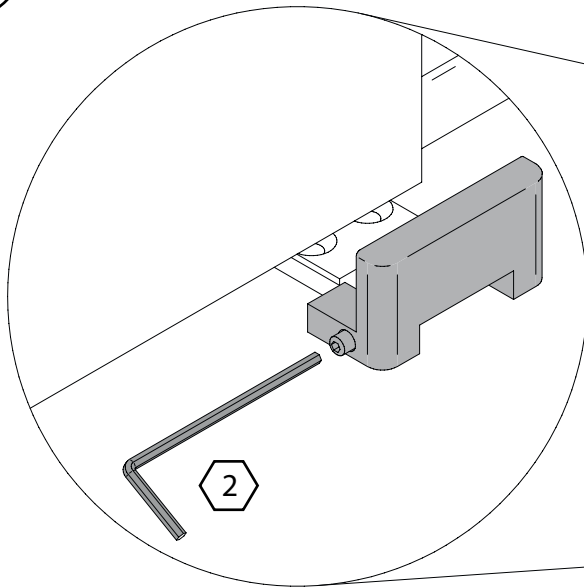

11

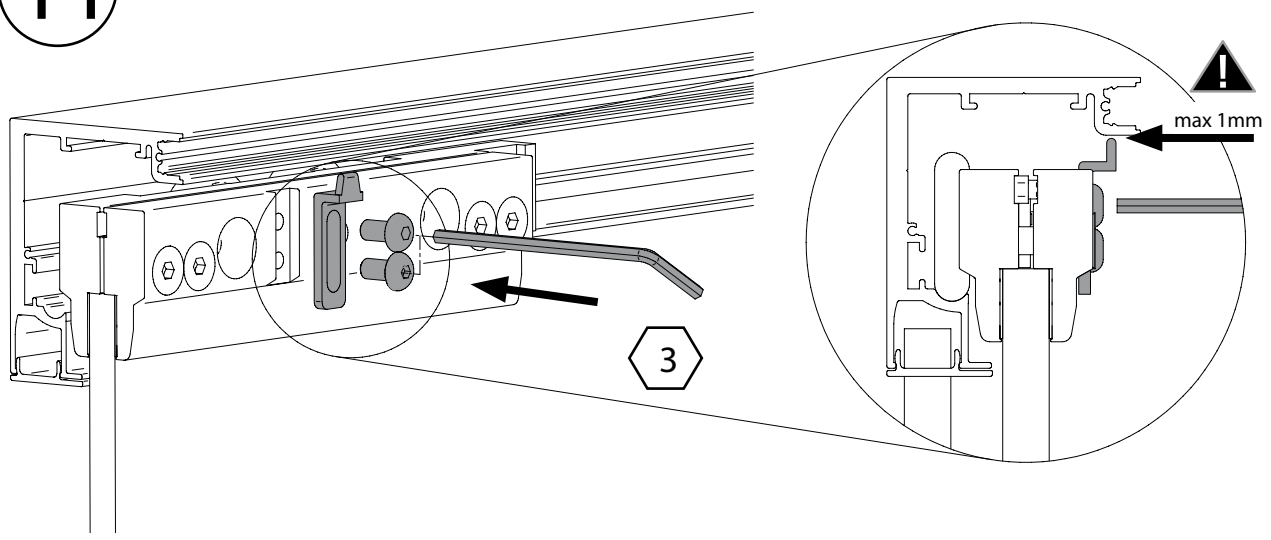

12

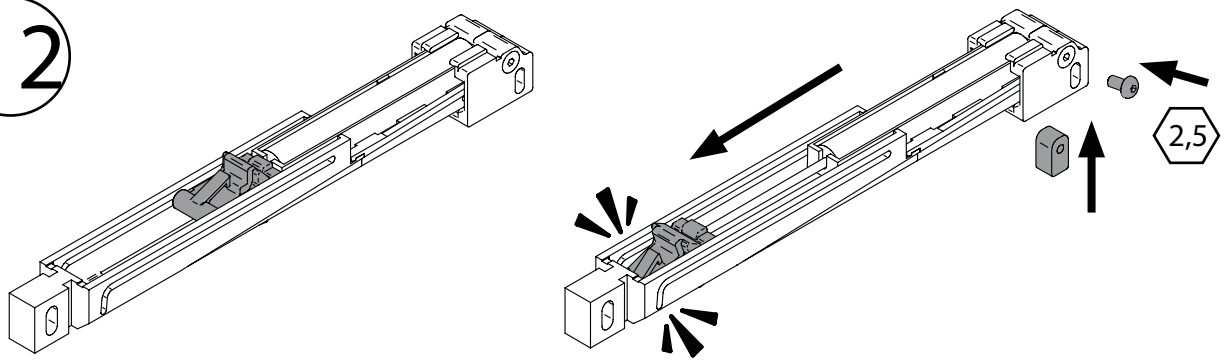

13

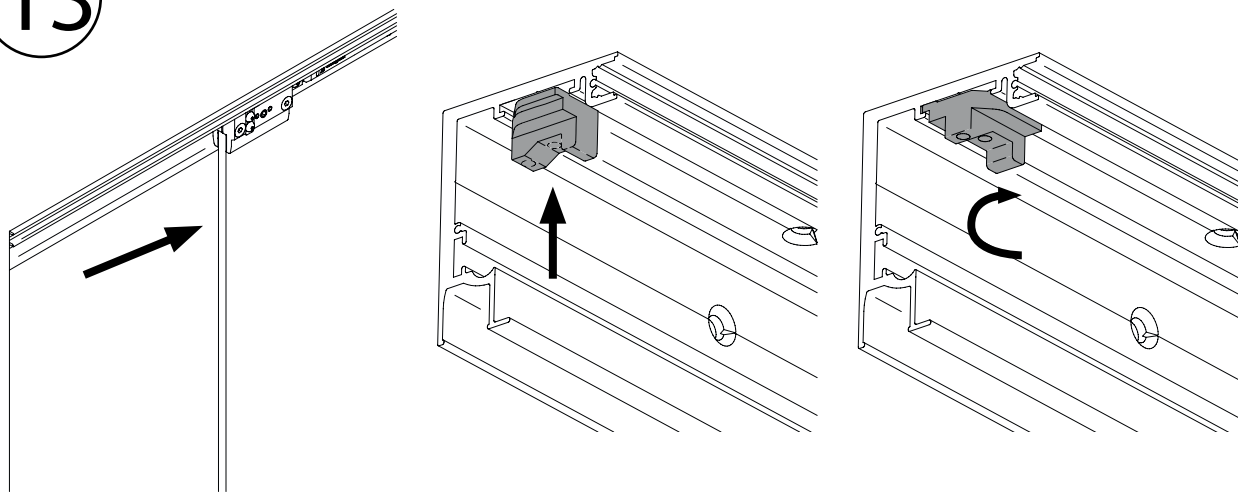

14

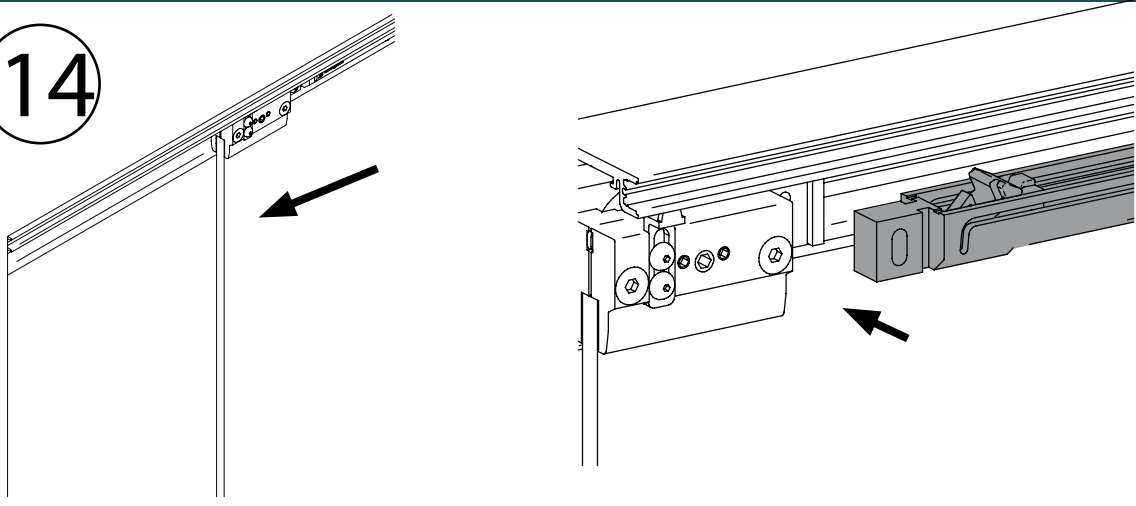

15

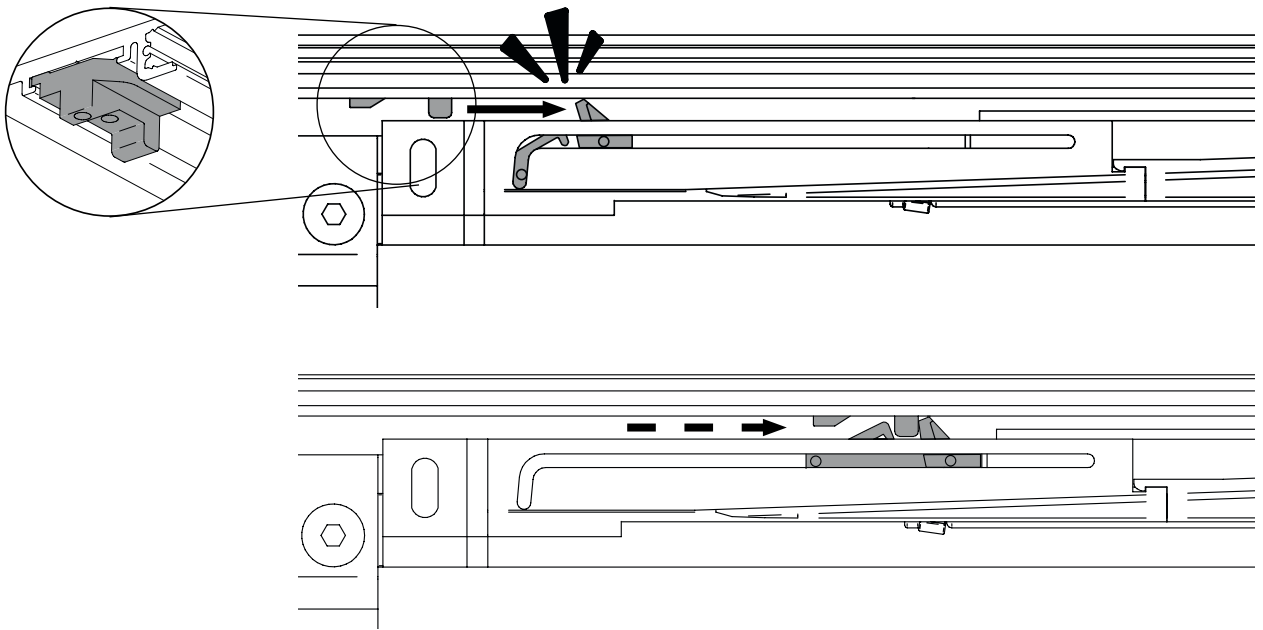

16

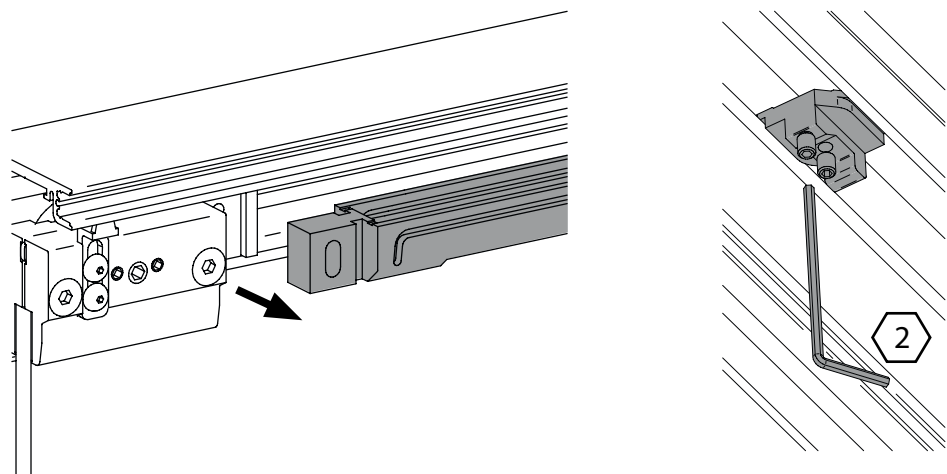

17

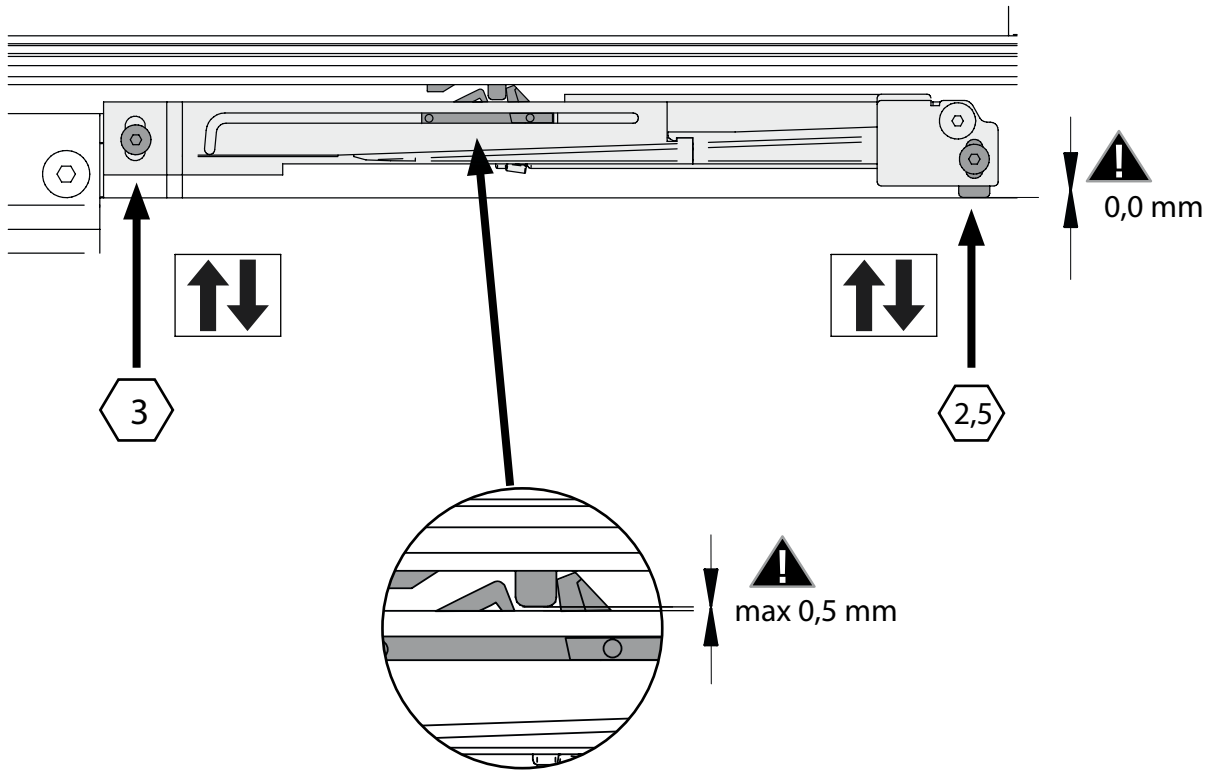
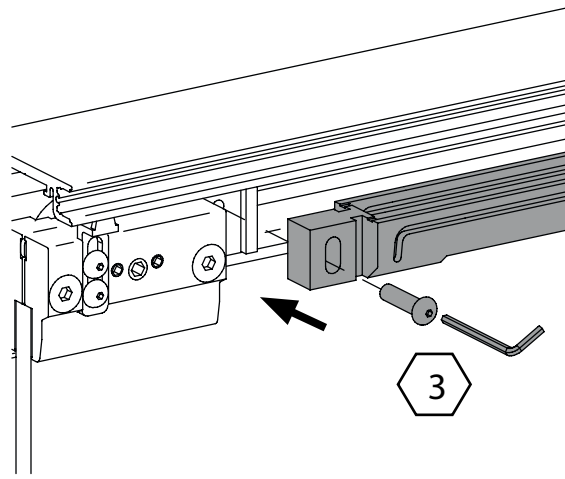

18

