

# EuroBulkSystems

The European journal for in-plant handling and processing of powders, granulates, pastes and liquids

INTERNATIONAL NEWS • PEOPLE • PRODUCTS

JULY/AUGUST 2011

ISSUE 22



# Clean system for high-temperature belt conveying of dusty materials

Standard Industrie International, Roubaix, France, has introduced a high-temperature version of its LIFTUBE® enclosed belt conveying system. Specially designed to transport hot products at over 120°C, and with a capability to withstand short-term exposure to temperatures up to 300°C, this is believed to be the first concept to optimise the sealing properties of enclosed belt conveyors, while retaining the benefits of the standard LIFTUBE. The company has also unveiled a large-width LIFTUBE which can accommodate belt widths of 1000-1600mm.

[www.standard-industrie.com](http://www.standard-industrie.com)

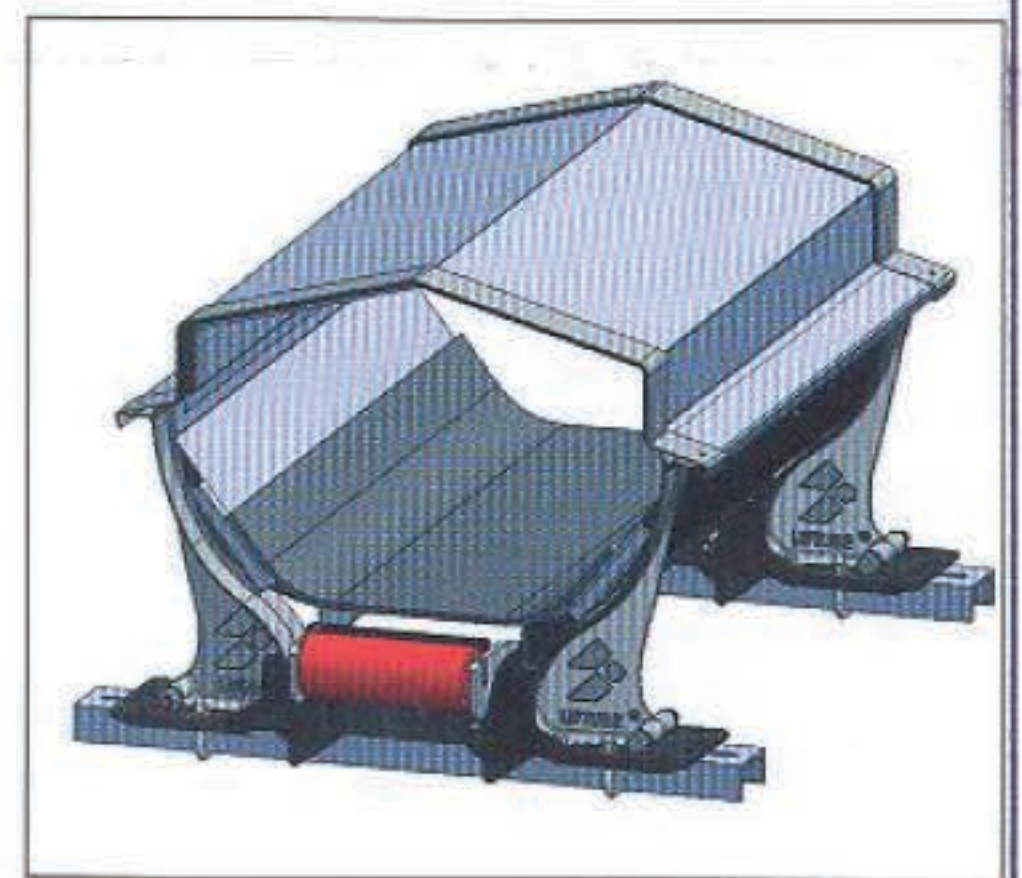

*Standard Industrie's large-width LIFTUBE belt conveyor installed in the Netherlands and (above) schematic of the high-temperature version.*